

FRAME HEIGHT AND RAMP ANGLE DATA

S/T TRUCK

S/T 10003 Pickup	1
Heights (To Ground)	1
Angle	1
Approach Angle(s) (Bottom of)	1
Departure Angle(s) (Bottom of)	1
108.0" Wheelbase – S 10603	2
118.0" Wheelbase – S 10803	2
123.0" Wheelbase – S 10653	3
122.9" Wheelbase – T 10643	3
123.0" Wheelbase – T 10653	4
S/T 10516 2-Door Utility	5
Heights (To Ground)	5
Angle	5
Approach Angle(s) (Bottom of)	5
Departure Angle(s) (Bottom of)	5
100.5" Wheelbase – S 10516	6
100.5" Wheelbase – T 10516	6
S/T 10506 4-Door Utility	7
Heights (To Ground)	7
Angle	7
Approach Angle(s) (Bottom of)	7
Departure Angle(s) (Bottom of)	7
107.0" Wheelbase – S 10506	8
107.0" Wheelbase – T 10506	8

FRAME HEIGHT AND RAMP ANGLE DATA

S/T TRUCK – (Continued)

S/T 15506, S/T 15806 4-Door Utility	9
Heights (To Ground)	9
Angle	9
Approach Angle(s) (Bottom of)	9
Departure Angle(s) (Bottom of)	9
113.0" Wheelbase – S 15506	10
129.0" Wheelbase – S 15806	10
113.0" Wheelbase – T 15506	11
129.0" Wheelbase – T 15806	11

C/K TRUCK

C/K 15000 Pickups	12
Heights (To Ground)	12
Angle	12
Approach Angle(s) (Bottom of)	12
Departure Angles(s) (Bottom of)	12
119.0" Wheelbase – C 15703	14
133.0" Wheelbase – C 15903	14
143.5" Wheelbase – C 15753	15
153.0" Wheelbase – C 15743	15
157.5" Wheelbase – C 15953	16
119.0" Wheelbase – K 15703	16
133.0" Wheelbase – K 15903	17
143.5" Wheelbase – K 15753	18
153.0" Wheelbase – K 15743	19
157.5" Wheelbase – K 15953	19

FRAME HEIGHT AND RAMP ANGLE DATA

C/K TRUCK – Continued

C/K 25000 Pickups & Chassis-Cabs	20
133.0" Wheelbase – C 25903	20
143.5" Wheelbase – C 25753	20
153.0" Wheelbase – C 25743	21
157.5" Wheelbase – C 25953	21
167.0" Wheelbase – C 25943	21
133.0" Wheelbase – K 25903	22
143.5" Wheelbase – K 25753	22
153.0" Wheelbase – K 25743	23
157.5" Wheelbase – K 25953	23
167.0" Wheelbase – K 25943	24
C/K 35000 Pickups & Chassis-Cabs	24
157.5" Wheelbase – C 35953	24
167.0" Wheelbase – C 35943	24
133.0" Wheelbase – K 35903	25
157.5" Wheelbase – K 35953	25
167.0" Wheelbase – K 35943	26
C/K 36000 Chassis-Cabs	26
137.0" Wheelbase – C 36003	26
161.5" Wheelbase – C 36053	26
161.5" Wheelbase – C 36403	27
185.5" Wheelbase – C 36453	27
137.0" Wheelbase – K 36003	27
161.5" Wheelbase – K 36053	28
161.5" Wheelbase – K 36403	28

FRAME HEIGHT AND RAMP ANGLE DATA

C/K TRUCK – Continued

185.5" Wheelbase – K 36453	28
C/K 15000/25000 Utility	29
Heights (To Ground)	29
Angle	29
Approach Angle(s) (Bottom of).....	29
Departure Angles(s) (Bottom of).....	29
116.0" Wheelbase – C 15706	30
130.0" Wheelbase – C 15906	30
116.0" Wheelbase – K 15706	31
130.0" Wheelbase – K 15906	32
130.0" Wheelbase – C 25906	32
130.0" Wheelbase – K 25906	33
C/K 15000/25000 Avalanche	34
Heights (To Ground)	34
Angle	34
Approach Angle(s) (Bottom of).....	34
Departure Angles(s) (Bottom of).....	34
130.0" Wheelbase – C 15936	35
130.0" Wheelbase – K 15936	35
130.0" Wheelbase – C 25936	36
130.0" Wheelbase – K 25936	36
H2 HUMMER	
H2 HUMMER.....	37
Heights (To Ground)	37
Angle	37

FRAME HEIGHT AND RAMP ANGLE DATA

HUMMER – *Continued*

Approach Angle(s) (Bottom of)	37
Departure Angle(s) (Bottom of)	37
000.0" Wheelbase – H2	38

M/L VAN

M/L 110(05, 06)	39
Heights (To Ground)	39
Angle	39
Approach Angle(s) (Bottom of)	39
Departure Angle(s) (Bottom of)	39
111.2" Wheelbase – M 11005	40
111.2" Wheelbase – M 11006	40
111.2" Wheelbase – L 11005	41
111.2" Wheelbase – L 11006	41

G/H VAN

G/H Full Body Van	42
Heights (To Ground)	42
Angle	42
Approach Angle(s) (Bottom of)	42
Departure Angle(s) (Bottom of)	42
135.0" Wheelbase – G 13405	43
135.0" Wheelbase – G 13406	43
135.0" Wheelbase – H 13405	43
135.0" Wheelbase – H 13406	44
135.0" Wheelbase – G 23405	44
135.0" Wheelbase – G 23406	45

FRAME HEIGHT AND RAMP ANGLE DATA

G/H VAN – *Continued*

155.0" Wheelbase – G 23705	45
155.0" Wheelbase – G 23706	45
135.0" Wheelbase – H 23405	46
135.0" Wheelbase – G 33405	46
135.0" Wheelbase – G 33406	46
155.0" Wheelbase – G 33705	47
155.0" Wheelbase – G 33706	47
G/H Cutaway Van	48
Heights (To Ground)	48
Angle	48
Approach Angle(s) (Bottom of).....	48
Departure Angle(s) (Bottom of)	48
139.0" Wheelbase – G 33503	49
159.0" Wheelbase – G 33803	50
177.0" Wheelbase – G 33903	50

FRAME HEIGHT AND RAMP ANGLE DATA

S/T 10003 Pickup

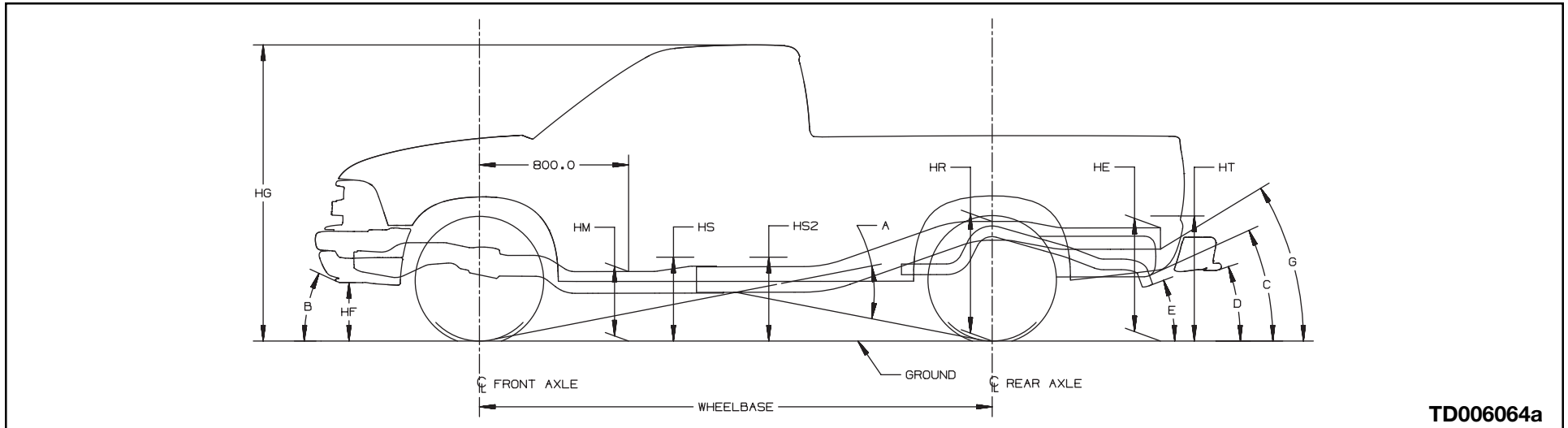

TD006064a

Heights (To Ground)

- HE Top of Frame at End
- HF Bottom of Front Air Deflector or Bumper
- HG Roof Height
- HM Normal Top of Frame
- HR Top of Frame at Centerline of Rear Axle
- HS Step H-Point-Front
- HS2 Step H-Point-Second
- HT Rear Cargo Load Height

Angle

- A Ramp Breakover

Approach Angle(s) (Bottom of)

- B Front Air Deflector

Departure Angle(s) (Bottom of)

- C Spare Tire
- D Rear Bumper
- E Tail pipe
- F Platform Hitch
- G Frame at End

NOTE: All weights are in pounds, dimensions are in inches and angles are in degrees.

FRAME HEIGHT AND RAMP ANGLE DATA

S 10603		108.0" Wheelbase				Frame Heights at Minimum Curb Weight							Frame Heights and Angular Dimensions are shown at Maximum GAWR Front/Rear																			
GVW/Tire	Minimum Curb Weight			GAWR		HE	HF	HG	HM	HP	HR	HS	HS2	HT	HE	HF	HG	HM	HP	HR	HS	HS2	HT	A	B	C	D	E	F	G	H	I
	Frnt	Rr	Ttl	Frnt	Rr																											
¹⁾ 4200 & Z83 P205/75R15	1857	1182	3039	2500	2300	-	12.4	62.7	14.7	-	25.7	18.0	-	27.0	-	10.5	60.9	12.9	-	22.4	16.2	-	22.6	20	23	17	15	17	-	-	-	-
²⁾ 4200 & Z08 P235/55R16	1892	1228	3120	2500	2300	-	10.2	61.4	13.2	-	24.9	16.7	-	26.6	-	7.7	59.7	11.0	-	21.8	14.6	-	22.4	17	17	16	15	16	-	-	-	-
²⁾ 4600 & Z85 P205/75R15	1861	1201	3062	2500	2700	-	11.9	63.5	15.2	-	27.3	18.8	-	29.2	-	10.4	61.2	13.1	-	22.7	16.5	-	23.1	21	23	18	16	18	-	-	-	-

S 10803		118.0" Wheelbase				Frame Heights at Minimum Curb Weight							Frame Heights and Angular Dimensions are shown at Maximum GAWR Front/Rear																			
GVW/Tire	Minimum Curb Weight			GAWR		HE	HF	HG	HM	HP	HR	HS	HS2	HT	HE	HF	HG	HM	HP	HR	HS	HS2	HT	A	B	C	D	E	F	G	H	I
	Frnt	Rr	Ttl	Frnt	Rr																											
¹⁾ 4600 & Z85 P205/75R15	1789	1349	3138	2500	2700	26.0	12.3	63.3	15.2	-	26.9	18.6	-	28.6	20.6	10.4	61.2	13.0	-	22.8	16.4	-	23.1	19	23	15	14	18	-	24	-	-
²⁾ 4900 & Z85 P205/75R15	1789	1349	3138	2500	2700	26.0	12.3	63.3	15.2	-	26.9	18.6	-	28.6	20.9	10.6	60.8	12.8	-	22.8	16.0	-	23.4	19	23	16	14	18	-	24	-	-

NOTE: Front coil springs, torsion bars and adjusters are computer selected based on model options and calculated sprung curb weight. Actual heights may vary due to production tolerances.

1) Base GVWR — contains minimum equipment required

2) Optional GVWR — contains minimum equipment required

(—) = not applicable for this model

FRAME HEIGHT AND RAMP ANGLE DATA

S 10653		123.0" Wheelbase				Frame Heights at Minimum Curb Weight								Frame Heights and Angular Dimensions are shown at Maximum GAWR Front/Rear																		
GVW/Tire	Minimum Curb Weight			GAWR		HE	HF	HG	HM	HP	HR	HS	HS2	HT	HE	HF	HG	HM	HP	HR	HS	HS2	HT	A	B	C	D	E	F	G	H	I
	Frnt	Rr	Ttl	Frnt	Rr																											
¹⁾ 4400 & Z83 P205/75R15	1856	1328	3184	2500	2300	-	12.6	62.4	14.6	-	25.1	17.7	18.9	26.2	-	10.7	60.7	12.7	-	22.3	15.9	17.1	22.8	18	23	17	15	17	-	-	-	-
²⁾ 4400 & Z08 P235/55R16	1892	1374	3266	2500	2300	-	10.4	61.0	12.9	-	24.3	16.3	17.7	25.8	-	7.9	59.4	10.8	-	21.7	14.2	15.9	22.7	14	17	17	15	16	-	-	-	-
²⁾ 4600 & Z85 P205/75R15	1861	1347	3208	2500	2700	-	12.1	63.3	15.0	-	26.8	18.4	19.9	28.5	-	10.4	61.2	13.0	-	22.7	16.4	17.5	23.2	19	23	18	16	18	-	-	-	-

T 10643		122.9" Wheelbase				Frame Heights at Minimum Curb Weight								Frame Heights and Angular Dimensions are shown at Maximum GAWR Front/Rear																		
GVW/Tire	Minimum Curb Weight			GAWR		HE	HF	HG	HM	HP	HR	HS	HS2	HT	HE	HF	HG	HM	HP	HR	HS	HS2	HT	A	B	C	D	E	F	G	H	I
	Frnt	Rr	Ttl	Frnt	Rr																											
¹⁾ 5150 & Z85 P235/70R15	2457	1623	4080	2800	2700	26.9	13.9	65.0	16.5	-	27.9	19.9	21.3	29.4	22.6	13.4	63.3	15.2	-	24.6	18.3	19.4	25.1	19	29	22	18	24	-	31	-	-
²⁾ 5150 & Z85 P235/75R15	2457	1623	4080	2800	2700	27.4	14.5	65.5	17.0	-	28.4	20.4	21.8	29.9	23.2	13.9	63.8	15.8	-	25.2	18.9	19.9	25.7	20	30	22	19	25	-	32	-	-

NOTE: Front coil springs, torsion bars and adjusters are computer selected based on model options and calculated sprung curb weight. Actual heights may vary due to production tolerances.

1) Base GVWR — contains minimum equipment required

2) Optional GVWR — contains minimum equipment required

(-) = not applicable for this model

FRAME HEIGHT AND RAMP ANGLE DATA

T 10653		123.0" Wheelbase				Frame Heights at Minimum Curb Weight								Frame Heights and Angular Dimensions are shown at Maximum GAWR Front/Rear																		
GVW/Tire	Minimum Curb Weight			GAWR		HE	HF	HG	HM	HP	HR	HS	HS2	HT	HE	HF	HG	HM	HP	HR	HS	HS2	HT	A	B	C	D	E	F	G	H	I
	Frt	Rr	Ttl	Frt	Rr																											
¹⁾ 4900 & ZR2 31x10.5R15	2421	1688	4109	2800	2700	-	17.3	67.7	19.7	-	30.8	22.9	24.3	32.1	-	16.4	66.4	18.5	-	27.3	21.7	22.5	27.4	26	35	26	21	25	-	-	-	-
²⁾ 5150 & Z85 P235/70R15	2274	1464	3738	2800	2700	-	13.9	65.0	16.7	-	28.5	20.2	21.6	30.1	-	12.8	62.8	14.9	-	24.7	18.1	19.2	25.3	19	28	22	19	24	-	-	-	-
²⁾ 5150 & Z85 P235/75R15	2274	1464	3738	2800	2700	-	14.4	65.5	17.2	-	29.0	20.7	22.1	30.6	-	13.3	63.4	15.5	-	25.2	18.6	19.7	25.8	20	29	23	19	26	-	-	-	-

NOTE: Front coil springs, torsion bars and adjusters are computer selected based on model options and calculated sprung curb weight. Actual heights may vary due to production tolerances.

1) Base GVWR — contains minimum equipment required

2) Optional GVWR — contains minimum equipment required

(—) = not applicable for this model

FRAME HEIGHT AND RAMP ANGLE DATA

S/T 10516 2-Door Utility

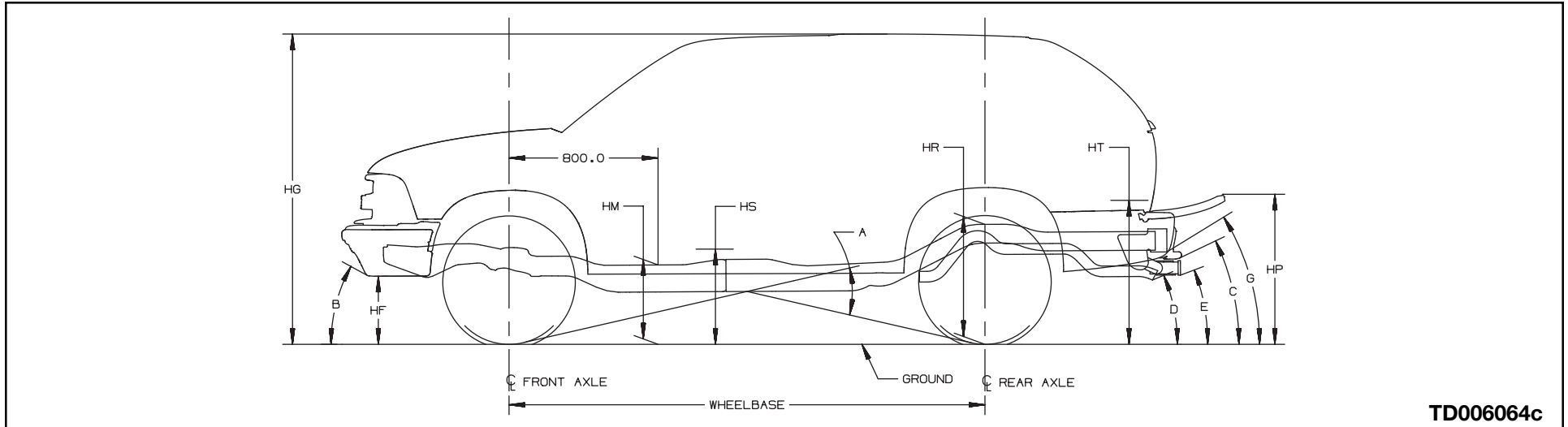

TD006064c

Heights (To Ground)

- HF Bottom of Front Air Deflector or Bumper
- HG Roof Height
- HM Normal Top of Frame
- HP Top of Tailgate (Down)
- HR Top of Frame at Centerline of Rear Axle
- HS Step H-Point-Front
- HT Rear Cargo Load Height

Angle

- A Ramp Breakover

Approach Angle(s) (Bottom of)

- B Front Air Deflector

Departure Angle(s) (Bottom of)

- C Rear Bumper
- D Tail pipe
- E Platform Hitch

NOTE: All weights are in pounds, dimensions are in inches and angles are in degrees.

FRAME HEIGHT AND RAMP ANGLE DATA

S 10516		100.5" Wheelbase					Frame Heights at Minimum Curb Weight							Frame Heights and Angular Dimensions are shown at Maximum GAWR Front/Rear																		
GVW/Tire	Minimum Curb Weight			GAWR		HE	HF	HG	HM	HP	HR	HS	HS2	HT	HE	HF	HG	HM	HP	HR	HS	HS2	HT	A	B	C	D	E	F	G	H	I
	Frnt	Rr	Ttl	Frnt	Rr																											
¹⁾ 4450 & Z85 P205/75R15	1958	1588	3546	2200	2600	-	14.0	65.3	16.5	32.2	25.1	19.8	-	30.3	-	13.7	63.8	15.5	28.0	22.4	18.5	-	26.7	23	29	22	20	17	-	-	-	-
²⁾ 4450 & Z85 P235/70R15	1958	1588	3546	2200	2600	-	14.4	65.7	16.9	32.6	25.6	20.2	-	30.7	-	14.1	64.2	15.9	28.4	22.9	18.9	-	27.1	24	30	22	20	17	-	-	-	-

T 10516		100.5" Wheelbase					Frame Heights at Minimum Curb Weight							Frame Heights and Angular Dimensions are shown at Maximum GAWR Front/Rear																		
GVW/Tire	Minimum Curb Weight			GAWR		HE	HF	HG	HM	HP	HR	HS	HS2	HT	HE	HF	HG	HM	HP	HR	HS	HS2	HT	A	B	C	D	E	F	G	H	I
	Frnt	Rr	Ttl	Frnt	Rr																											
¹⁾ 4850 & Z85 P205/75R15	2146	1667	3813	2500	2700	-	13.7	65.1	16.2	32.0	24.9	19.6	-	30.1	-	12.8	63.4	14.9	27.9	22.2	18.1	-	26.6	23	27	22	19	17	-	-	-	-
²⁾ 4850 & Z85 P235/70R15	2146	1667	3813	2500	2700	-	14.1	65.5	16.6	32.4	25.3	20.0	-	30.5	-	13.2	63.8	15.3	28.3	22.6	18.5	-	27.0	24	28	22	20	17	-	-	-	-
²⁾ 4850 & ZM6 P235/75R15	2138	1731	3869	2500	2700	-	14.7	65.8	17.1	32.6	25.6	20.4	-	30.8	-	13.7	64.3	15.8	28.9	23.2	19.0	-	27.6	25	29	23	21	18	-	-	-	-
²⁾ 5000 & ZR2 31x10.5R15	2226	1866	4092	2500	2700	-	17.7	67.6	19.4	33.5	27.2	22.4	-	31.9	-	17.2	66.3	18.4	30.7	25.2	21.3	-	29.5	31	36	26	25	21	-	-	-	-

NOTE: Front coil springs, torsion bars and adjusters are computer selected based on model options and calculated sprung curb weight. Actual heights may vary due to production tolerances.

1) Base GVWR — contains minimum equipment required

2) Optional GVWR — contains minimum equipment required

(—) = not applicable for this model

FRAME HEIGHT AND RAMP ANGLE DATA

S/T 10506 4-Door Utility

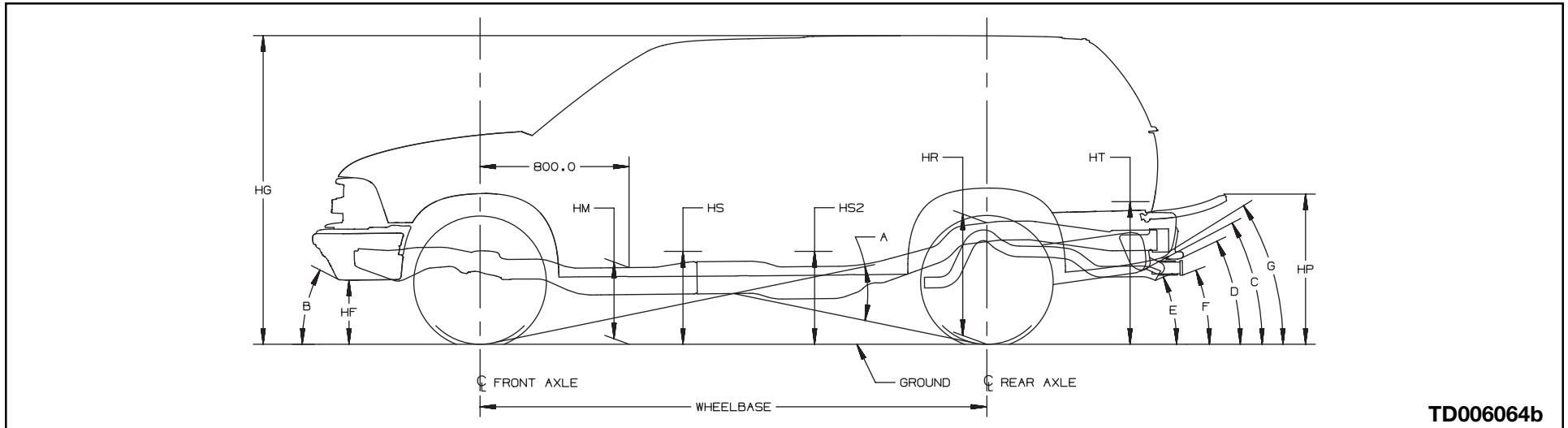

Heights (To Ground)

- HF Bottom of Front Air Deflector or Bumper
- HG Roof Height
- HM Normal Top of Frame
- HP Top of Tailgate (Down)
- HR Top of Frame at Centerline of Rear Axle
- HS Step H-Point-Front
- HS2 Step H-Point-Second
- HT Rear Cargo Load Height

Angle

- A Ramp Breakover

Approach Angle(s) (Bottom of)

- B Front Air Deflector

Departure Angle(s) (Bottom of)

- C Spare Tire
- D Rear Bumper
- E Tail pipe
- F Platform Hitch

NOTE: All weights are in pounds, dimensions are in inches and angles are in degrees.

FRAME HEIGHT AND RAMP ANGLE DATA

S 10506		107.0" Wheelbase					Frame Heights at Minimum Curb Weight							Frame Heights and Angular Dimensions are shown at Maximum GAWR Front/Rear																		
GVW/Tire	Minimum Curb Weight			GAWR		HE	HF	HG	HM	HP	HR	HS	HS2	HT	HE	HF	HG	HM	HP	HR	HS	HS2	HT	A	B	C	D	E	F	G	H	I
	Frnt	Rr	Ttl	Frnt	Rr																											
¹⁾ 5000 & ZW7 P235/70R15	2060	1664	3724	2500	2700	-	13.6	65.2	16.3	32.5	25.3	19.7	19.7	30.8	-	12.6	63.1	14.7	28.6	22.4	17.9	17.4	27.3	21	27	22	23	20	18	-	-	-
²⁾ 5000 & Z85 P205/75R15	2038	1659	3697	2500	2800	-	13.8	64.9	16.2	31.9	24.9	19.5	19.5	30.3	-	12.9	63.0	14.7	27.7	22.0	17.8	17.2	26.6	21	27	21	22	19	16	-	-	-

T 10506		107.0" Wheelbase					Frame Heights at Minimum Curb Weight							Frame Heights and Angular Dimensions are shown at Maximum GAWR Front/Rear																		
GVW/Tire	Minimum Curb Weight			GAWR		HE	HF	HG	HM	HP	HR	HS	HS2	HT	HE	HF	HG	HM	HP	HR	HS	HS2	HT	A	B	C	D	E	F	G	H	I
	Frnt	Rr	Ttl	Frnt	Rr																											
¹⁾ 5350 & ZW7 P235/70R15	2421	1797	4218	2800	2700	-	14.1	65.0	16.4	31.7	24.8	19.6	19.5	30.2	-	13.2	63.1	15.0	28.4	22.5	18.0	17.5	27.2	21	28	22	22	20	17	-	-	-
²⁾ 5350 & Z85 P235/70R15	2401	1794	4195	2800	2900	-	14.1	65.0	16.4	31.9	24.9	19.7	19.6	30.3	-	13.0	63.3	15.0	27.8	22.3	18.1	17.5	26.7	21	28	21	22	19	17	-	-	-
²⁾ 5350 & Z85 P205/75R15	2401	1794	4195	2800	2900	-	13.7	64.6	16.0	31.4	24.5	19.3	19.2	29.8	-	12.7	62.9	14.6	27.3	21.9	17.7	17.1	26.3	20	27	20	21	19	16	-	-	-
²⁾ 5350 & Z85 P235/75R15	2401	1794	4195	2800	2900	-	14.6	65.5	16.9	32.4	25.4	20.2	20.1	30.8	-	13.6	63.8	15.5	28.3	22.8	18.6	18.0	27.2	22	29	22	22	20	17	-	-	-

NOTE: Front coil springs, torsion bars and adjusters are computer selected based on model options and calculated sprung curb weight. Actual heights may vary due to production tolerances.

1) Base GVWR — contains minimum equipment required

2) Optional GVWR — contains minimum equipment required

(—) = not applicable for this model

FRAME HEIGHT AND RAMP ANGLE DATA

S/T 15506, S/T 15806 4-Door Utility

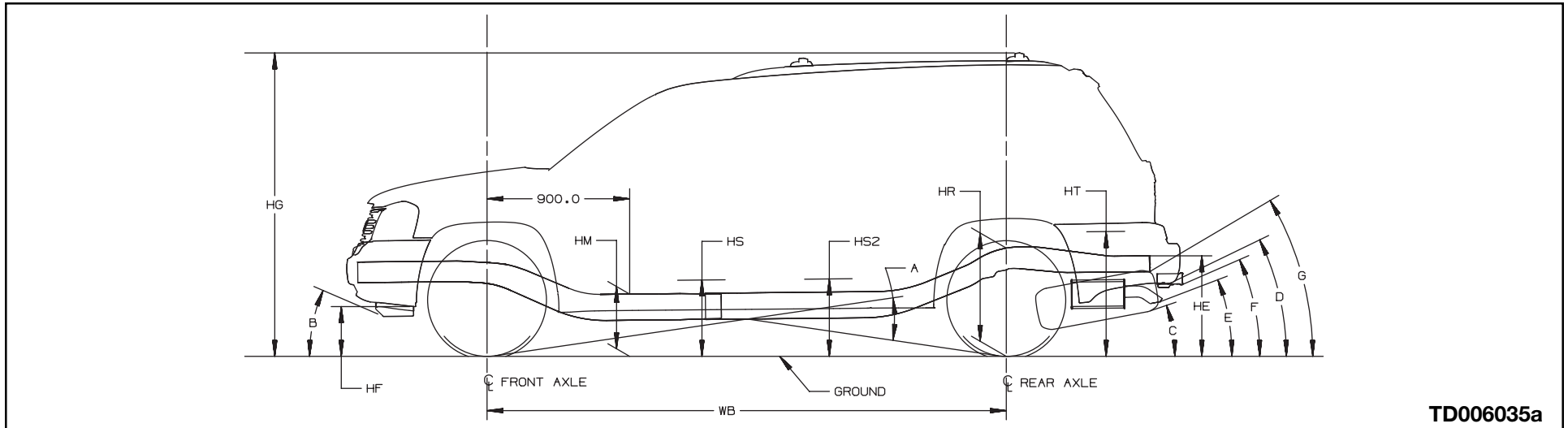

TD006035a

Heights (To Ground)

- HF Bottom of Front Air Deflector or Bumper
- HG Roof Height
- HM Normal Top of Frame
- HP Top of Tailgate (Down)
- HR Top of Frame at Centerline of Rear Axle
- HS Step H-Point-Front
- HS2 Step H-Point-Second
- HT Rear Cargo Load Height

Angle

- A Ramp Breakover
- Approach Angle(s) (Bottom of)**
- B Front Air Deflector
- Departure Angle(s) (Bottom of)**
- C Spare Tire
 - D Rear Bumper
 - E Tail pipe
 - F Platform Hitch

NOTE: All weights are in pounds, dimensions are in inches and angles are in degrees.

FRAME HEIGHT AND RAMP ANGLE DATA

S 15506		113.0" Wheelbase				Frame Heights at Minimum Curb Weight								Frame Heights and Angular Dimensions are shown at Maximum GAWR Front/Rear																		
GVW/Tire	Minimum Curb Weight			GAWR		HE	HF	HG	HM	HP	HR	HS	HS2	HT	HE	HF	HG	HM	HP	HR	HS	HS2	HT	A	B	C	D	E	F	G	H	I
	Frnt	Rr	Ttl	Frnt	Rr																											
¹⁾ 5550 P245/65R17	2316	1957	4723	2950	3200	-	8.9	73.4	15.7	-	28.9	18.8	20.2	34.0	-	6.9	71.1	13.5	-	24.9	16.7	17.3	28.9	16	19	18	23	19	21	-	-	-
²⁾ 5550 P245/70R16	2316	1957	4723	2950	3200	-	8.7	73.2	15.4	-	28.7	18.6	20.0	33.8	-	6.6	70.9	13.3	-	24.7	16.4	17.1	28.6	16	19	18	22	19	21	-	-	-

S 15806		129.0" Wheelbase				Frame Heights at Minimum Curb Weight								Frame Heights and Angular Dimensions are shown at Maximum GAWR Front/Rear																		
GVW/Tire	Minimum Curb Weight			GAWR		HE	HF	HG	HM	HP	HR	HS	HS2	HT	HE	HF	HG	HM	HP	HR	HS	HS2	HT	A	B	C	D	E	F	G	H	I
	Frnt	Rr	Ttl	Frnt	Rr																											
¹⁾ 6200 P245/65R17	2507	2256	4763	3100	3400	-	8.6	76.3	15.1	-	29.6	18.3	19.4	33.0	-	6.7	74.2	13.2	-	26.8	16.3	17.2	29.6	16	20	21	23	21	23	-	-	-
¹⁾ 6200 & LM4 P245/65R17	2545	2267	4812	3100	3400	-	10.2	76.2	16.0	-	29.5	19.2	19.8	32.5	-	8.7	74.2	14.3	-	26.9	17.6	18.0	29.4	17	24	21	23	20	23	-	-	-

NOTE: Front coil springs, torsion bars and adjusters are computer selected based on model options and calculated sprung curb weight. Actual heights may vary due to production tolerances.

1) Base GVWR — contains minimum equipment required

2) Optional GVWR — contains minimum equipment required

(-) = not applicable for this model

FRAME HEIGHT AND RAMP ANGLE DATA

T 15506		113.0" Wheelbase				Frame Heights at Minimum Curb Weight								Frame Heights and Angular Dimensions are shown at Maximum GAWR Front/Rear																		
GVW/Tire	Minimum Curb Weight			GAWR		HE	HF	HG	HM	HP	HR	HS	HS2	HT	HE	HF	HG	HM	HP	HR	HS	HS2	HT	A	B	C	D	E	F	G	H	I
	Frnt	Rr	Ttl	Frnt	Rr																											
¹⁾ 5750 P245/65R17	2462	1995	4457	2950	3200	-	9.1	73.3	15.7	-	28.8	18.9	20.2	33.8	-	7.8	70.8	13.7	-	25.0	16.9	17.3	28.9	17	21	18	23	19	21	-	-	-
²⁾ 5750 P245/70R16	2462	1995	4457	2950	3200	-	8.9	73.1	15.5	-	28.6	18.7	20.0	33.6	-	7.6	70.5	13.5	-	24.7	16.7	17.1	28.7	16	21	18	23	19	21	-	-	-
²⁾ 5750 & Z70 P255/60R17	2509	1972	4481	2950	3200	-	8.9	71.8	14.8	-	27.1	18.0	18.8	31.7	-	7.2	71.5	13.8	-	26.7	17.0	18.5	31.3	16	20	21	25	22	24	-	-	-

T 15806		129.0" Wheelbase				Frame Heights at Minimum Curb Weight								Frame Heights and Angular Dimensions are shown at Maximum GAWR Front/Rear																		
GVW/Tire	Minimum Curb Weight			GAWR		HE	HF	HG	HM	HP	HR	HS	HS2	HT	HE	HF	HG	HM	HP	HR	HS	HS2	HT	A	B	C	D	E	F	G	H	I
	Frnt	Rr	Ttl	Frnt	Rr																											
¹⁾ 6400 P245/65R17	2653	2290	4943	3200	3400	-	8.8	76.2	15.2	-	29.5	18.4	19.4	32.8	-	7.3	73.9	13.4	-	26.7	16.6	17.3	29.6	16	21	21	23	21	23	-	-	-
¹⁾ 6400 & LM4 P245/65R17	2694	2302	4996	3200	3400	-	10.0	76.1	15.9	-	29.4	19.1	19.7	32.5	-	8.8	74.0	14.3	-	26.9	17.5	17.8	29.4	17	25	21	23	21	23	-	-	-

NOTE: Front coil springs, torsion bars and adjusters are computer selected based on model options and calculated sprung curb weight. Actual heights may vary due to production tolerances.

1) Base GVWR — contains minimum equipment required

2) Optional GVWR — contains minimum equipment required

(—) = not applicable for this model

FRAME HEIGHT AND RAMP ANGLE DATA

C/K Truck - Pickups

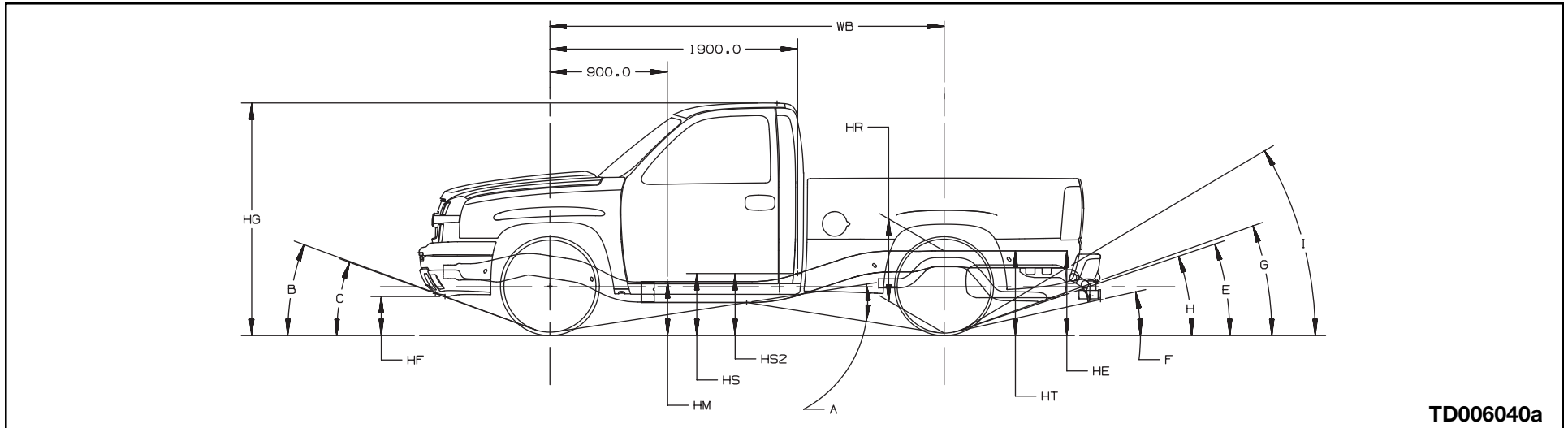

TD006040a

Heights (To Ground)

- HE Top of Frame at End
- HF Bottom of Front Air Deflector or Bumper
- HG Roof height to ground
- HM Normal Top of Frame
- HP Top of Tailgate
- HR Top of Frame at Centerline of Rear Axle
- HS Step H-Point-Front
- HS2 Step H-Point-Second
- HT Rear Cargo Load Height

Angle

- A Ramp Breakover

Approach Angle(s) (Bottom of)

- B Front Bumper
- C Front Air Deflector

Departure Angle(s) (Bottom of)

- D Fuel Tank and Shield
- E Spare Tire
- F Platform Hitch
- G Rear Bumper
- H Exhaust
- I Frame at End

NOTE: All weights are in pounds, dimensions are in inches and angles are in degrees.

FRAME HEIGHT AND RAMP ANGLE DATA

C/K Truck - Chassis-Cab

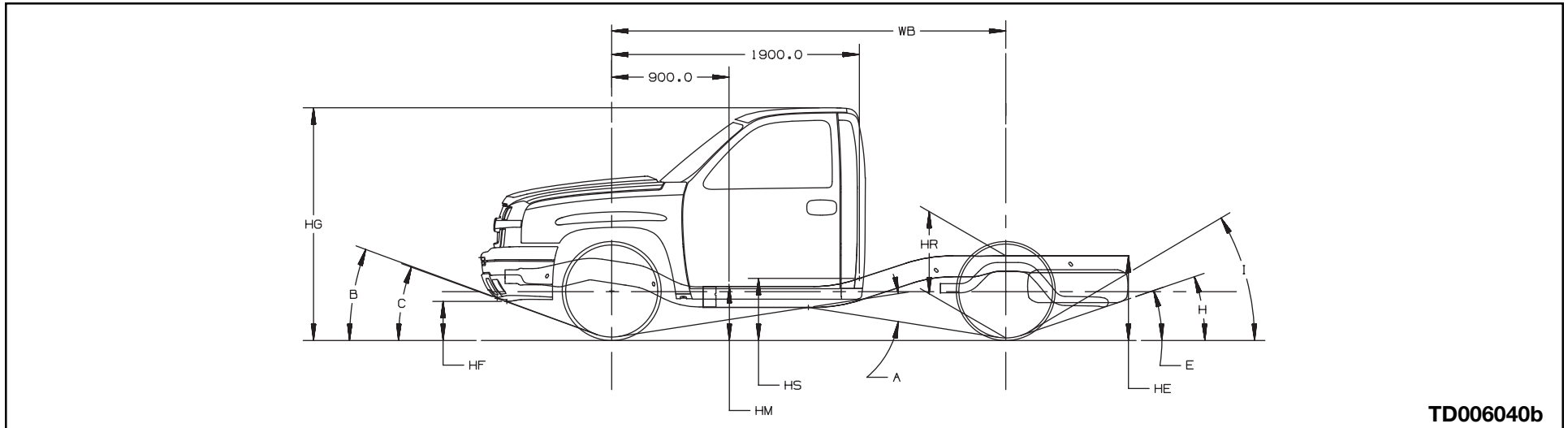

TD006040b

Heights (To Ground)

- HE Top of Frame at End
- HF Bottom of Front Air Deflector or Bumper
- HG Roof height to ground
- HM Normal Top of Frame
- HP Top of Tailgate
- HR Top of Frame at Centerline of Rear Axle
- HS Step H-Point-Front
- HS2 Step H-Point-Second
- HT Rear Cargo Load Height

Angle

- A Ramp Breakover

Approach Angle(s) (Bottom of)

- B Front Bumper
- C Front Air Deflector

Departure Angle(s) (Bottom of)

- D Fuel Tank and Shield
- E Spare Tire
- F Platform Hitch
- G Rear Bumper
- H Exhaust
- I Frame at End

NOTE: All weights are in pounds, dimensions are in inches and angles are in degrees.

FRAME HEIGHT AND RAMP ANGLE DATA

C 15703		119.0" Wheelbase				Frame Heights at Minimum Curb Weight								Frame Heights and Angular Dimensions are shown at Maximum GAWR Front/Rear																		
GVW/Tire	Minimum Curb Weight			GAWR		HE	HF	HF (mce)	HG	HM	HR	HS	HS2	HT	HE	HF	HF (mce)	HG	HM	HR	HS	HS2	HT	A	B/mce	C/mce	D	E	F	G	H	I
	Frt	Rr	Ttl	Frt	Rr																											
¹⁾ 6100 P235/75R16	2392	1656	4048	3150	3686	30.2	9.1	9.3	71.4	16.3	28.8	19.6	-	32.9	23.7	7.5	7.7	68.4	13.8	23.8	17.1	-	26.1	18	29/37	19/18	-	20	15	21	20	31
²⁾ 6100 P255/70R16	2392	1656	4048	3150	3686	30.3	9.2	9.4	71.5	16.4	28.9	19.8	-	33.0	23.8	7.7	7.9	68.6	14.0	23.9	17.3	-	26.3	19	29/37	19/18	-	19	15	21	20	32

C 15903		133.0" Wheelbase				Frame Heights at Minimum Curb Weight								Frame Heights and Angular Dimensions are shown at Maximum GAWR Front/Rear																		
GVW/Tire	Minimum Curb Weight			GAWR		HE	HF	HF (mce)	HG	HM	HR	HS	HS2	HT	HE	HF	HF (mce)	HG	HM	HR	HS	HS2	HT	A	B/mce	C/mce	D	E	F	G	H	I
	Frt	Rr	Ttl	Frt	Rr																											
¹⁾ 6400 P235/75R16	2478	1710	4188	3150	3686	30.2	9.7	9.8	71.3	16.5	28.9	19.8	-	32.9	24.0	8.5	8.7	68.5	14.1	24.0	17.5	-	26.5	17	30/38	20/19	-	20	14	19	20	28
²⁾ 6400 P255/70R16	2478	1710	4188	3150	3686	30.3	9.8	9.9	71.5	16.6	29.0	19.9	-	33.0	24.2	8.6	8.8	68.6	14.3	24.2	17.6	-	26.7	17	30/39	21/19	-	20	14	20	21	28

NOTE: Front coil springs, torsion bars and adjusters are computer selected based on model options and calculated sprung curb weight. Actual heights may vary due to production tolerances.

1) Base GVWR — contains minimum equipment required

2) Optional GVWR — contains minimum equipment required

(—) = not applicable for this model

FRAME HEIGHT AND RAMP ANGLE DATA

C 15753		143.5" Wheelbase				Frame Heights at Minimum Curb Weight								Frame Heights and Angular Dimensions are shown at Maximum GAWR Front/Rear																		
GVW/Tire	Minimum Curb Weight			GAWR		HE	HF	HF (mce)	HG	HM	HR	HS	HS2	HT	HE	HF	HF (mce)	HG	HM	HR	HS	HS2	HT	A	B/mce	C/mce	D	E	F	G	H	I
	Frnt	Rr	Ttl	Frnt	Rr																											
¹⁾ 6200 P235/75R16	2666	1780	4446	3600	3686	29.5	9.8	10.0	71.6	16.3	28.5	19.6	20.7	32.2	23.7	7.7	7.9	69.3	14.1	23.9	17.4	18.5	26.1	16	29/37	19/18	—	20	15	21	20	31
²⁾ 6200 P255/70R16	2666	1780	4446	3600	3686	29.7	9.9	10.0	71.7	16.4	28.7	19.7	20.8	32.3	23.8	7.7	7.9	69.4	14.1	24.1	17.5	18.6	26.3	16	29/37	19/18	—	20	15	21	20	32
²⁾ 6200 LT245/75R16	2666	1780	4446	3600	3686	30.0	10.4	10.6	72.1	16.9	29.0	20.2	21.2	32.6	24.3	8.4	8.5	69.8	14.7	24.6	18.0	19.1	26.7	17	30/38	20/19	—	20	15	21	20	32
²⁾ 6600 & NYS P255/70R16	2772	2227	4999	3600	4000	29.1	9.6	9.8	71.3	16.1	28.2	19.4	20.4	31.8	23.8	7.7	7.9	69.2	14.1	24.0	17.4	18.4	26.2	16	29/37	19/18	—	20	15	21	20	32

C 15743		153.0" Wheelbase				Frame Heights at Minimum Curb Weight								Frame Heights and Angular Dimensions are shown at Maximum GAWR Front/Rear																		
GVW/Tire	Minimum Curb Weight			GAWR		HE	HF	HF (mce)	HG	HM	HR	HS	HS2	HT	HE	HF	HF (mce)	HG	HM	HR	HS	HS2	HT	A	B/mce	C/mce	D	E	F	G	H	I
	Frnt	Rr	Ttl	Frnt	Rr																											
¹⁾ 8600 LT245/75R16	3091	2311	5402	4410	6000	32.2	13.1	13.3	75.2	20.4	31.4	22.9	23.7	34.8	26.3	11.2	11.4	72.7	18.2	26.8	20.6	21.6	28.7	14	36/44	26/24	—	18	14	20	19	27
¹⁾ 8600 & NYS LT245/75R16	3103	2294	5397	4410	6000	32.9	13.0	13.2	75.5	20.6	31.9	23.1	24.0	35.5	26.6	11.2	11.4	72.8	18.2	27.0	20.7	21.7	29.0	14	36/44	26/24	—	18	15	20	20	28

NOTE: Front coil springs, torsion bars and adjusters are computer selected based on model options and calculated sprung curb weight. Actual heights may vary due to production tolerances.

1) Base GVWR — contains minimum equipment required

2) Optional GVWR — contains minimum equipment required

(—) = not applicable for this model

FRAME HEIGHT AND RAMP ANGLE DATA

C 15953		157.5" Wheelbase				Frame Heights at Minimum Curb Weight							Frame Heights and Angular Dimensions are shown at Maximum GAWR Front/Rear																			
GVW/Tire	Minimum Curb Weight			GAWR		HE	HF	HF (mce)	HG	HM	HR	HS	HS2	HT	HE	HF	HF (mce)	HG	HM	HR	HS	HS2	HT	A	B/mce	C/mce	D	E	F	G	H	I
	Frnt	Rr	Ttl	Frnt	Rr																											
¹⁾ 6400 P235/75R16	2891	1823	4714	3600	3686	29.4	9.9	10.1	71.3	16.2	28.4	19.5	20.5	32.1	23.7	8.6	8.8	69.4	14.4	23.9	17.7	18.6	26.1	15	31/39	21/20	-	20	13	19	20	28
²⁾ 6400 P255/70R16	2805	1712	4517	3600	3686	29.6	10.0	10.2	71.5	16.3	28.6	19.7	20.6	32.2	23.8	8.8	9.0	69.5	14.5	24.1	17.8	18.7	26.2	15	31/39	21/20	-	20	13	19	20	28

K 15703		119.0" Wheelbase				Frame Heights at Minimum Curb Weight							Frame Heights and Angular Dimensions are shown at Maximum GAWR Front/Rear																			
GVW/Tire	Minimum Curb Weight			GAWR		HE	HF	HF (mce)	HG	HM	HR	HS	HS2	HT	HE	HF	HF (mce)	HG	HM	HR	HS	HS2	HT	A	B/mce	C/mce	D	E	F	G	H	I
	Frnt	Rr	Ttl	Frnt	Rr																											
¹⁾ 6100 P245/75R16	2612	1829	4441	3925	3750	31.6	12.2	12.3	73.6	18.8	30.5	22.1	-	34.3	25.6	8.7	8.8	71.1	16.0	26.0	20.7	-	28.1	23	31/40	21/20	-	23	17	23	24	34
²⁾ 6100 LT245/75R16	2612	1829	4441	3925	3750	31.9	12.5	12.7	73.9	19.1	30.8	22.4	-	34.5	26.1	9.2	9.3	71.5	16.4	26.4	21.1	-	28.6	23	31/40	21/20	-	23	17	23	24	34
²⁾ 6100 P265/75R16	2612	1829	4441	3925	3750	32.3	12.8	13.0	74.2	19.4	31.2	22.8	-	34.9	26.3	9.4	9.5	71.8	16.6	26.6	21.3	-	28.7	24	33/41	23/21	-	23	18	24	25	35
²⁾ 6100 LT265/75R16	2612	1829	4441	3925	3750	32.4	13.3	13.5	74.5	19.8	31.3	23.1	-	35.0	26.4	10.0	10.1	72.1	17.1	26.8	21.7	-	28.9	24	33/41	23/21	-	24	18	24	25	35

NOTE: Front coil springs, torsion bars and adjusters are computer selected based on model options and calculated sprung curb weight. Actual heights may vary due to production tolerances.

1) Base GVWR — contains minimum equipment required

2) Optional GVWR — contains minimum equipment required

(—) = not applicable for this model

FRAME HEIGHT AND RAMP ANGLE DATA

K 15903		133.0" Wheelbase				Frame Heights at Minimum Curb Weight								Frame Heights and Angular Dimensions are shown at Maximum GAWR Front/Rear																		
GVW/Tire	Minimum Curb Weight			GAWR		HE	HF	HF (mce)	HG	HM	HR	HS	HS2	HT	HE	HF	HF (mce)	HG	HM	HR	HS	HS2	HT	A	B/mce	C/mce	D	E	F	G	H	I
	Frt	Rr	Ttl	Frt	Rr																											
¹⁾ 6400 P245/75R16	2709	1776	4485	3925	3750	31.9	12.2	12.3	73.5	18.7	30.7	22.0	-	34.5	25.6	9.1	9.2	71.0	16.0	26.0	19.3	-	28.0	21	32/40	22/20	-	23	15	21	24	30
²⁾ 6400 LT245/75R16	2709	1776	4485	3925	3750	32.1	12.5	12.7	73.8	19.0	31.0	22.4	-	34.8	26.1	9.6	9.7	71.4	16.4	26.4	19.8	-	28.5	21	32/40	22/21	-	23	15	21	24	30
²⁾ 6400 P265/75R16	2709	1776	4485	3925	3750	32.5	12.8	13.0	74.1	19.4	31.3	22.7	-	35.2	26.2	9.7	9.9	71.6	16.6	26.6	20.0	-	28.7	22	34/42	24/22	-	23	16	22	25	31
²⁾ 6400 LT265/75R16	2709	1776	4485	3925	3750	32.6	13.3	13.5	74.4	19.7	31.5	23.0	-	35.2	26.4	10.3	10.5	72.0	17.1	26.8	20.4	-	28.8	22	34/42	24/22	-	23	16	22	25	31

NOTE: Front coil springs, torsion bars and adjusters are computer selected based on model options and calculated sprung curb weight. Actual heights may vary due to production tolerances.

1) Base GVWR — contains minimum equipment required

2) Optional GVWR — contains minimum equipment required

(-) = not applicable for this model

FRAME HEIGHT AND RAMP ANGLE DATA

K 15753		143.5" Wheelbase				Frame Heights at Minimum Curb Weight								Frame Heights and Angular Dimensions are shown at Maximum GAWR Front/Rear																		
GVW/Tire	Minimum Curb Weight			GAWR		HE	HF	HF (mce)	HG	HM	HR	HS	HS2	HT	HE	HF	HF (mce)	HG	HM	HR	HS	HS2	HT	A	B/mce	C/mce	D	E	F	G	H	I
	Frt	Rr	Ttl	Frt	Rr																											
¹⁾ 6400 P245/75R16	2988	1827	4815	3925	3750	31.6	12.2	12.3	73.7	18.5	30.6	21.9	22.9	34.2	25.5	9.8	10.0	71.7	16.4	26.0	19.7	20.9	27.9	20	34/42	24/22	-	23	17	23	24	34
²⁾ 6400 LT245/75R16	2988	1827	4815	3925	3750	31.8	12.5	12.7	74.1	18.9	30.9	22.2	23.2	34.4	26.0	10.3	10.5	72.1	16.8	26.4	20.1	21.3	28.5	20	34/42	24/22	-	23	17	23	24	34
²⁾ 6400 P265/75R16	2988	1827	4815	3925	3750	32.2	12.8	13.0	74.4	19.2	31.2	22.5	23.5	34.8	26.2	10.5	10.6	72.3	17.0	26.6	20.3	21.5	28.6	21	35/44	25/23	-	23	17	24	25	35
²⁾ 6400 LT265/75R16	2988	1827	4815	3925	3750	32.3	13.3	13.5	74.7	19.6	31.4	22.9	23.8	34.9	26.3	11.1	11.3	72.7	17.5	26.9	20.8	21.8	28.8	21	35/44	25/23	-	23	17	24	25	35
²⁾ 6900 & NYS P245/75R16	2981	2231	5212	3925	4000	31.2	12.2	12.4	73.5	18.5	30.3	21.8	22.7	33.8	25.9	9.9	10.1	71.4	16.2	26.1	19.5	20.6	28.3	20	34/42	24/22	-	23	17	24	24	34
²⁾ 6900 & NYS P265/75R16	2981	2231	5212	3925	4000	31.8	12.9	13.0	74.2	19.1	30.9	22.4	23.4	34.4	26.5	10.6	10.8	72.1	16.9	26.8	20.2	21.3	29.0	21	35/44	25/23	-	24	18	25	26	35
²⁾ 6900 & NYS LT245/75R16	2981	2231	5212	3925	4000	31.5	12.6	12.8	73.9	18.8	30.6	22.1	23.1	34.1	26.4	10.4	10.6	71.9	16.7	26.6	20.0	21.1	28.8	20	34/42	24/22	-	22	17	24	24	35
²⁾ 6900 & NYS LT265/75R16	2981	2231	5212	3925	4000	32.7	13.3	13.4	74.9	19.7	31.8	23.0	24.0	35.4	27.7	11.0	11.2	72.8	17.5	27.8	20.8	22.0	30.2	21	35/44	25/23	-	24	18	25	26	36
²⁾ 7200 & NYS P265/70R17	3046	2353	5399	3925	4000	31.4	12.8	12.9	73.9	18.9	30.6	22.2	23.1	34.0	26.7	11.1	11.3	71.8	17.0	26.8	20.3	21.0	29.2	21	36/45	27/24	-	24	18	25	26	36

↑ CENTENNIAL

NOTE: Front coil springs, torsion bars and adjusters are computer selected based on model options and calculated sprung curb weight. Actual heights may vary due to production tolerances.

1) Base GVWR — contains minimum equipment required

2) Optional GVWR — contains minimum equipment required

(—) = not applicable for this model

FRAME HEIGHT AND RAMP ANGLE DATA

K 15743		153.0" Wheelbase				Frame Heights at Minimum Curb Weight								Frame Heights and Angular Dimensions are shown at Maximum GAWR Front/Rear																		
GVW/Tire	Minimum Curb Weight			GAWR		HE	HF	HF (mce)	HG	HM	HR	HS	HS2	HT	HE	HF	HF (mce)	HG	HM	HR	HS	HS2	HT	A	B/mce	C/mce	D	E	F	G	H	I
	Frnt	Rr	Ttl	Frnt	Rr																											
¹⁾ 8600 LT245/75R16	3429	2393	5822	4410	6000	32.1	13.1	13.2	75.1	20.4	31.3	22.8	23.6	34.7	26.2	11.7	11.9	72.9	18.5	26.8	21.0	21.8	28.6	19	37/45	27/25	—	18	14	19	19	27
¹⁾ 8600 & NYS LT245/75R16	3433	2406	5839	4410	6000	32.7	13.0	13.1	75.3	20.5	31.7	23.0	23.8	35.3	26.5	11.7	11.9	73.0	18.5	27.0	21.0	21.9	28.8	19	37/45	27/25	—	18	14	20	19	28

K 15953		157.5" Wheelbase				Frame Heights at Minimum Curb Weight								Frame Heights and Angular Dimensions are shown at Maximum GAWR Front/Rear																		
GVW/Tire	Minimum Curb Weight			GAWR		HE	HF	HF (mce)	HG	HM	HR	HS	HS2	HT	HE	HF	HF (mce)	HG	HM	HR	HS	HS2	HT	A	B/mce	C/mce	D	E	F	G	H	I
	Frnt	Rr	Ttl	Frnt	Rr																											
¹⁾ 6400 P245/75R16	3115	1883	4998	3925	3750	31.2	12.2	12.4	73.3	18.4	30.3	21.7	22.5	33.8	25.4	10.6	10.8	71.8	16.7	25.9	20.0	20.9	27.8	18	35/43	25/23	—	22	15	21	23	30
¹⁾ 6400 LT245/75R16	3115	1883	4998	3925	3750	31.5	12.6	12.8	73.7	18.7	30.6	22.0	22.9	34.1	25.9	11.1	11.3	72.2	17.1	26.3	20.4	21.3	28.3	18	35/43	25/23	—	22	15	21	23	30
²⁾ 6400 P265/75R16	3115	1883	4998	3925	3750	31.9	12.9	13.0	74.0	19.0	30.9	22.3	23.2	34.5	26.0	11.2	11.4	72.4	17.3	26.5	20.6	21.6	28.4	19	37/45	27/25	—	23	16	21	25	31
²⁾ 6400 LT265/75R16	3115	1883	4998	3925	3750	31.9	13.4	13.6	74.3	19.4	31.1	22.7	23.5	34.5	26.2	11.8	12.0	72.8	17.8	26.8	21.1	21.9	28.6	19	37/45	27/25	—	23	16	21	25	31

NOTE: Front coil springs, torsion bars and adjusters are computer selected based on model options and calculated sprung curb weight. Actual heights may vary due to production tolerances.

1) Base GVWR — contains minimum equipment required

2) Optional GVWR — contains minimum equipment required

(—) = not applicable for this model

FRAME HEIGHT AND RAMP ANGLE DATA

C 25903		133.0" Wheelbase				Frame Heights at Minimum Curb Weight							Frame Heights and Angular Dimensions are shown at Maximum GAWR Front/Rear																			
GVW/Tire	Minimum Curb Weight			GAWR		HE	HF	HF (mce)	HG	HM	HR	HS	HS2	HT	HE	HF	HF (mce)	HG	HM	HR	HS	HS2	HT	A	B/mce	C/mce	D	E	F	G	H	I
	Frnt	Rr	Ttl	Frnt	Rr																											
²⁾ 8500 AF LT245/75R16	3019	2469	5488	4100	6000	33.8	13.2	13.4	74.0	20.2	32.8	22.9	-	34.3	28.3	11.7	11.9	72.3	18.3	28.9	20.9	-	28.7	19	37/45	27/25	-	20	15	21	27	29
¹⁾ 8600 LT245/75R16	2908	1929	4837	4100	6000	35.1	13.0	13.1	74.6	20.5	33.9	23.3	-	35.7	28.4	11.5	11.7	72.1	18.1	28.9	20.8	-	28.8	19	36/45	26/24	-	20	16	21	27	29
²⁾ 8600 & ZW9 LT245/75R16	2910	1574	4484	4100	6000	36.1	12.8	13.0	74.9	20.7	34.5	23.5	-	-	28.4	11.5	11.7	72.1	18.1	28.9	20.8	-	-	19	36/45	26/24	-	-	-	-	27	29
²⁾ 9200 LT245/75R16	2861	2131	4992	4410	6084	34.8	13.0	13.2	76.4	20.4	33.6	25.2	-	37.3	28.6	10.9	11.1	73.8	17.7	28.9	22.4	-	31.1	18	35/43	25/23	-	21	16	23	27	29
²⁾ 9200 & ZW9 LT245/75R16	2872	1769	4641	4410	6084	35.7	12.9	13.0	76.8	20.6	34.3	25.4	-	-	28.6	10.9	11.1	73.8	17.7	28.9	22.4	-	-	18	35/43	25/23	-	-	-	-	27	29

C 25753		143.5" Wheelbase				Frame Heights at Minimum Curb Weight							Frame Heights and Angular Dimensions are shown at Maximum GAWR Front/Rear																			
GVW/Tire	Minimum Curb Weight			GAWR		HE	HF	HF (mce)	HG	HM	HR	HS	HS2	HT	HE	HF	HF (mce)	HG	HM	HR	HS	HS2	HT	A	B/mce	C/mce	D	E	F	G	H	I
	Frnt	Rr	Ttl	Frnt	Rr																											
¹⁾ 9200 LT245/75R16	3036	2191	5227	4410	6084	34.5	13.1	13.2	76.8	20.3	33.5	25.0	25.7	37.0	28.6	11.2	11.4	74.0	17.8	28.9	22.5	23.3	31.1	18	36/44	26/24	-	21	18	26	21	33

NOTE: Front coil springs, torsion bars and adjusters are computer selected based on model options and calculated sprung curb weight. Actual heights may vary due to production tolerances.

1) Base GVWR — contains minimum equipment required

2) Optional GVWR — contains minimum equipment required

(—) = not applicable for this model

FRAME HEIGHT AND RAMP ANGLE DATA

C 25743		153.0" Wheelbase			Frame Heights at Minimum Curb Weight									Frame Heights and Angular Dimensions are shown at Maximum GAWR Front/Rear																		
GVW/Tire	Minimum Curb Weight			GAWR		HE	HF	HF (mce)	HG	HM	HR	HS	HS2	HT	HE	HF	HF (mce)	HG	HM	HR	HS	HS2	HT	A	B/mce	C/mce	D	E	F	G	H	I
	Frt	Rr	Ttl	Frt	Rr																											
¹⁾ 9200 LT245/75R16	3087	2316	5403	4410	6084	34.1	13.2	13.3	77.3	20.2	33.3	24.9	25.6	36.6	28.6	11.3	11.5	74.6	17.8	28.9	22.5	23.3	31.1	17	36/44	26/24	-	21	18	26	27	33

C 25953		157.5" Wheelbase			Frame Heights at Minimum Curb Weight									Frame Heights and Angular Dimensions are shown at Maximum GAWR Front/Rear																		
GVW/Tire	Minimum Curb Weight			GAWR		HE	HF	HF (mce)	HG	HM	HR	HS	HS2	HT	HE	HF	HF (mce)	HG	HM	HR	HS	HS2	HT	A	B/mce	C/mce	D	E	F	G	H	I
	Frt	Rr	Ttl	Frt	Rr																											
²⁾ 8500 AF LT245/75R16	3255	2750	6005	4500	6084	33.1	13.3	13.5	76.0	20.0	32.4	24.6	25.0	35.6	28.2	11.4	11.5	74.9	18.1	28.9	22.7	24.2	30.7	17	36/44	26/24	-	22	15	22	27	29
¹⁾ 9200 LT245/75R16	3157	2197	5354	4500	6084	34.5	13.2	13.3	76.6	20.2	33.5	25.0	25.5	37.0	28.6	11.3	11.5	74.1	17.8	28.9	22.5	23.5	31.1	17	36/44	26/24	-	22	16	23	27	29

C 25943		167.0" Wheelbase			Frame Heights at Minimum Curb Weight									Frame Heights and Angular Dimensions are shown at Maximum GAWR Front/Rear																		
GVW/Tire	Minimum Curb Weight			GAWR		HE	HF	HF (mce)	HG	HM	HR	HS	HS2	HT	HE	HF	HF (mce)	HG	HM	HR	HS	HS2	HT	A	B/mce	C/mce	D	E	F	G	H	I
	Frt	Rr	Ttl	Frt	Rr																											
¹⁾ 9200 LT245/75R16	3193	2374	5567	4670	6084	34.0	13.2	13.4	77.1	20.1	33.2	24.8	25.4	36.5	28.6	11.1	11.3	74.7	17.7	28.9	22.3	23.4	31.0	16	35/44	26/24	-	21	16	23	22	29
²⁾ 9200 & ZW9 LT245/75R16	3201	2032	5233	4670	6084	34.9	13.1	13.3	77.4	20.2	33.8	25.0	25.8	-	28.6	11.1	11.3	74.7	17.7	28.9	22.3	23.4	-	16	35/44	26/24	-	-	-	-	22	29

NOTE: Front coil springs, torsion bars and adjusters are computer selected based on model options and calculated sprung curb weight. Actual heights may vary due to production tolerances.

1) Base GVWR — contains minimum equipment required

2) Optional GVWR — contains minimum equipment required

(-) = not applicable for this model

FRAME HEIGHT AND RAMP ANGLE DATA

K 25903		133.0" Wheelbase				Frame Heights at Minimum Curb Weight								Frame Heights and Angular Dimensions are shown at Maximum GAWR Front/Rear																		
GVW/Tire	Minimum Curb Weight			GAWR		HE	HF	HF (mce)	HG	HM	HR	HS	HS2	HT	HE	HF	HF (mce)	HG	HM	HR	HS	HS2	HT	A	B/mce	C/mce	D	E	F	G	H	I
	Frnt	Rr	Ttl	Frnt	Rr																											
²⁾ 8500 AF LT245/75R16	3206	2753	5959	4500	6084	33.2	13.3	13.4	75.5	20.1	32.4	24.8	-	35.7	28.1	11.2	11.4	74.7	18.1	28.9	22.8	-	30.6	19	36/44	26/24	-	20	15	22	27	29
²⁾ 9200 & ZW9 LT245/75R16	3115	1789	4904	4500	6084	35.7	12.9	13.0	76.4	20.6	34.3	25.4	-	-	28.5	11.2	11.4	74.0	17.9	28.9	22.5	-	-	18	36/44	26/24	-	-	-	-	27	29
¹⁾ 9200 LT245/75R16	3094	2214	5308	4500	6084	34.6	13.1	13.2	76.0	20.4	33.5	25.1	-	37.1	28.5	11.1	11.3	74.0	17.9	28.9	22.5	-	31.0	18	36/44	26/24	-	21	16	23	27	29
²⁾ 9200 & ZW9 LT245/75R16	3117	1791	4908	4800	6084	35.7	12.9	13.1	76.4	20.6	34.3	25.4	-	-	28.5	10.6	10.8	74.0	17.7	28.9	22.4	-	-	18	34/43	25/23	-	-	-	-	27	29
²⁾ 9200 LT245/75R16	3169	2145	5314	4800	6084	34.8	13.1	13.2	76.1	20.4	33.6	25.2	-	37.3	28.5	10.7	10.9	74.1	17.7	28.9	22.4	-	31.0	18	35/43	25/23	-	21	16	23	27	29

NOTE: Vehicles in rows 7 & 8 have (VYU).

K 25753		143.5" Wheelbase				Frame Heights at Minimum Curb Weight								Frame Heights and Angular Dimensions are shown at Maximum GAWR Front/Rear																		
GVW/Tire	Minimum Curb Weight			GAWR		HE	HF	HF (mce)	HG	HM	HR	HS	HS2	HT	HE	HF	HF (mce)	HG	HM	HR	HS	HS2	HT	A	B/mce	C/mce	D	E	F	G	H	I
	Frnt	Rr	Ttl	Frnt	Rr																											
¹⁾ 8600 LT245/75R16	3215	2061	5276	4410	6000	34.8	13.0	13.1	74.9	20.3	33.8	23.1	23.7	35.3	28.4	11.4	11.6	72.6	18.1	28.9	20.8	21.9	28.9	19	36/44	26/24	-	20	17	25	21	33
²⁾ 8600 & VYU LT245/75R16	3214	2062	5276	4500	6000	34.8	13.0	13.2	74.9	20.4	33.8	23.1	23.7	35.3	28.4	11.3	11.4	72.6	18.1	28.9	20.7	21.9	28.9	19	36/44	26/24	-	20	17	25	21	33
²⁾ 9200 LT245/75R16	3235	2164	5399	4670	6084	34.5	13.1	13.2	76.8	20.3	33.6	25.1	25.7	37.0	28.5	11.1	11.2	74.1	17.8	28.9	22.5	23.5	31.0	18	35/44	26/24	-	20	17	25	21	33
²⁾ 9200 & VYU LT245/75R16	3235	2165	5400	4800	6084	34.5	13.1	13.3	76.8	20.3	33.6	25.1	25.7	37.0	28.5	10.9	11.0	74.2	17.7	28.9	22.4	23.5	31.0	18	35/43	25/23	-	20	17	25	21	33

NOTE: Front coil springs, torsion bars and adjusters are computer selected based on model options and calculated sprung curb weight. Actual heights may vary due to production tolerances.

1) Base GVWR — contains minimum equipment required

2) Optional GVWR — contains minimum equipment required

(-) = not applicable for this model

FRAME HEIGHT AND RAMP ANGLE DATA

K 25743		153.0" Wheelbase				Frame Heights at Minimum Curb Weight								Frame Heights and Angular Dimensions are shown at Maximum GAWR Front/Rear																		
GVW/Tire	Minimum Curb Weight			GAWR		HE	HF	HF (mce)	HG	HM	HR	HS	HS2	HT	HE	HF	HF (mce)	HG	HM	HR	HS	HS2	HT	A	B/mce	C/mce	D	E	F	G	H	I
	Frnt	Rr	Ttl	Frnt	Rr																											
¹⁾ 9200 LT245/75R16	3339	2339	5678	4670	6084	34.1	13.1	13.3	77.2	20.2	33.2	24.9	25.6	36.6	28.5	11.2	11.4	74.7	17.9	28.9	22.5	23.4	31.0	17	36/44	26/24	—	21	17	25	27	33
²⁾ 9200 & VYU LT245/75R16	3412	2431	5843	4800	6084	33.8	13.2	13.4	77.2	20.1	33.1	24.8	25.5	36.3	28.5	11.2	11.4	74.8	17.9	28.9	22.5	23.5	31.0	17	36/44	26/24	—	20	17	25	27	33

K 25953		157.5" Wheelbase				Frame Heights at Minimum Curb Weight								Frame Heights and Angular Dimensions are shown at Maximum GAWR Front/Rear																		
GVW/Tire	Minimum Curb Weight			GAWR		HE	HF	HF (mce)	HG	HM	HR	HS	HS2	HT	HE	HF	HF (mce)	HG	HM	HR	HS	HS2	HT	A	B/mce	C/mce	D	E	F	G	H	I
	Frnt	Rr	Ttl	Frnt	Rr																											
²⁾ 8500 AF LT245/75R16	3470	2770	6240	4670	6084	33.1	13.3	13.5	75.9	19.9	32.4	24.6	25.0	35.6	28.2	11.4	11.5	75.1	18.1	28.9	22.8	24.3	30.6	17	36/44	26/24	—	22	15	22	27	29
¹⁾ 9200 LT245/75R16	3372	2217	5589	4670	6084	34.5	13.1	13.3	76.5	20.2	33.5	24.9	25.5	37.0	28.5	11.3	11.5	74.3	17.9	28.9	22.5	23.7	31.0	17	36/44	26/24	—	22	16	23	27	29
²⁾ 9200 & VYU LT245/75R16	3375	2220	5595	4800	6084	34.5	13.2	13.3	76.5	20.2	33.5	24.9	25.5	37.0	28.5	11.1	11.3	74.3	17.8	28.9	22.5	23.7	31.0	17	35/44	26/24	—	22	16	23	27	29

NOTE: Front coil springs, torsion bars and adjusters are computer selected based on model options and calculated sprung curb weight. Actual heights may vary due to production tolerances.

1) Base GVWR — contains minimum equipment required

2) Optional GVWR — contains minimum equipment required

(—) = not applicable for this model

FRAME HEIGHT AND RAMP ANGLE DATA

K 25943		167.0" Wheelbase				Frame Heights at Minimum Curb Weight							Frame Heights and Angular Dimensions are shown at Maximum GAWR Front/Rear																			
GVW/Tire	Minimum Curb Weight			GAWR		HE	HF	HF (mce)	HG	HM	HR	HS	HS2	HT	HE	HF	HF (mce)	HG	HM	HR	HS	HS2	HT	A	B/mce	C/mce	D	E	F	G	H	I
	Frt	Rr	Ttl	Frt	Rr																											
¹⁾ 9200 LT245/75R16	3447	2461	5908	4800	6084	33.8	13.3	13.5	77.0	20.1	33.0	24.7	25.6	36.3	28.5	11.3	11.5	74.9	17.9	28.9	22.5	23.6	30.9	16	36/44	26/24	-	20	16	23	22	29
²⁾ 9200 & ZW9 LT245/75R16	3436	2198	5634	4800	6084	34.5	13.2	13.4	77.2	20.2	33.5	24.9	25.7	-	28.5	11.3	11.5	74.9	17.8	28.9	22.5	23.6	-	16	36/44	26/24	-	-	-	-	22	29

C 35953		157.5" Wheelbase				Frame Heights at Minimum Curb Weight							Frame Heights and Angular Dimensions are shown at Maximum GAWR Front/Rear																			
GVW/Tire	Minimum Curb Weight			GAWR		HE	HF	HF (mce)	HG	HM	HR	HS	HS2	HT	HE	HF	HF (mce)	HG	HM	HR	HS	HS2	HT	A	B/mce	C/mce	D	E	F	G	H	I
	Frt	Rr	Ttl	Frt	Rr																											
¹⁾ 11400 LT215/85R16	3158	2693	5851	4670	8550	35.2	13.1	13.2	76.8	20.4	34.0	25.1	25.7	37.7	28.5	11.1	11.3	74.4	17.6	28.9	22.2	23.8	31.0	16	35/44	26/24	-	22	16	23	27	29

C 35943		167.0" Wheelbase				Frame Heights at Minimum Curb Weight							Frame Heights and Angular Dimensions are shown at Maximum GAWR Front/Rear																			
GVW/Tire	Minimum Curb Weight			GAWR		HE	HF	HF (mce)	HG	HM	HR	HS	HS2	HT	HE	HF	HF (mce)	HG	HM	HR	HS	HS2	HT	A	B/mce	C/mce	D	E	F	G	H	I
	Frt	Rr	Ttl	Frt	Rr																											
¹⁾ 11400 LT215/85R16	3238	2779	6017	4670	8550	34.9	13.1	13.3	77.4	20.3	33.9	25.0	25.8	37.4	28.5	11.2	11.4	75.0	17.6	28.9	22.3	23.7	31.0	15	36/44	26/24	-	22	16	23	22	29
²⁾ 11400 & ZW9 LT215/85R16	3251	2370	5621	4670	8550	35.9	13.1	13.2	77.9	20.5	34.6	25.2	26.2	-	28.5	11.4	11.6	75.0	17.7	28.9	22.3	23.7	-	15	36/44	26/24	-	-	-	-	22	29

NOTE: Front coil springs, torsion bars and adjusters are computer selected based on model options and calculated sprung curb weight. Actual heights may vary due to production tolerances.

1) Base GVWR — contains minimum equipment required

2) Optional GVWR — contains minimum equipment required

(-) = not applicable for this model

FRAME HEIGHT AND RAMP ANGLE DATA

K 35903		133.0" Wheelbase				Frame Heights at Minimum Curb Weight								Frame Heights and Angular Dimensions are shown at Maximum GAWR Front/Rear																		
GVW/Tire	Minimum Curb Weight			GAWR		HE	HF	HF (mce)	HG	HM	HR	HS	HS2	HT	HE	HF	HF (mce)	HG	HM	HR	HS	HS2	HT	A	B/mce	C/mce	D	E	F	G	H	I
	Frnt	Rr	Ttl	Frnt	Rr																											
¹⁾ 11400 LT215/85R16	3173	2534	5707	4500	8550	35.7	12.9	13.1	76.4	20.6	34.3	25.5	—	38.2	28.4	11.5	11.7	74.4	17.9	28.9	22.5	—	30.9	18	36/44	26/24	—	22	15	23	27	29
²⁾ 11400 & ZW9 LT215/85R16	3172	2208	5380	4500	8550	36.5	12.8	12.9	76.7	20.8	34.9	25.7	—	—	28.4	11.5	11.7	74.4	17.9	28.9	22.5	—	—	18	36/44	26/24	—	—	—	—	27	29
²⁾ 11400 & VYU LT215/85R16	3186	2535	5721	4800	8550	35.7	12.9	13.1	76.4	20.6	34.3	25.5	—	38.2	28.4	10.9	11.1	74.4	17.6	28.9	22.3	—	30.9	18	35/43	25/23	—	22	15	23	27	29
²⁾ 11400 & ZW9 LT215/85R16	3185	2209	5394	4800	8550	36.5	12.8	12.9	76.7	20.8	34.9	25.7	—	—	28.4	10.9	11.1	74.4	17.6	28.9	22.3	—	—	18	35/43	25/23	—	—	—	—	27	29

K 35953		157.5" Wheelbase				Frame Heights at Minimum Curb Weight								Frame Heights and Angular Dimensions are shown at Maximum GAWR Front/Rear																		
GVW/Tire	Minimum Curb Weight			GAWR		HE	HF	HF (mce)	HG	HM	HR	HS	HS2	HT	HE	HF	HF (mce)	HG	HM	HR	HS	HS2	HT	A	B/mce	C/mce	D	E	F	G	H	I
	Frnt	Rr	Ttl	Frnt	Rr																											
¹⁾ 11400 LT215/85R16	3391	2629	6020	4800	8550	35.3	13.1	13.2	76.9	20.4	34.1	25.1	25.8	37.8	28.4	11.3	11.5	74.6	17.8	28.9	22.4	24.0	30.9	16	36/44	26/24	—	22	15	23	27	29

NOTE: Front coil springs, torsion bars and adjusters are computer selected based on model options and calculated sprung curb weight. Actual heights may vary due to production tolerances.

1) Base GVWR — contains minimum equipment required

2) Optional GVWR — contains minimum equipment required

(—) = not applicable for this model

FRAME HEIGHT AND RAMP ANGLE DATA

K 35943		167.0" Wheelbase					Frame Heights at Minimum Curb Weight							Frame Heights and Angular Dimensions are shown at Maximum GAWR Front/Rear																		
GVW/Tire	Minimum Curb Weight			GAWR		HE	HF	HF (mce)	HG	HM	HR	HS	HS2	HT	HE	HF	HF (mce)	HG	HM	HR	HS	HS2	HT	A	B/mce	C/mce	D	E	F	G	H	I
	Frt	Rr	Ttl	Frt	Rr																											
¹ 11400 LT215/85R16	3503	2803	6306	4800	8550	34.8	13.1	13.3	77.4	20.3	33.8	25.0	25.8	37.3	28.4	11.5	11.7	75.1	17.8	28.9	22.4	23.9	30.9	15	36/44	26/24	-	22	15	23	22	29
² 11400 & ZW9 LT215/85R16	3503	2476	5979	4800	8550	35.6	13.0	13.2	77.7	20.4	34.4	25.1	26.1	-	28.4	11.5	11.7	75.1	17.8	28.9	22.4	23.9	-	15	36/44	26/24	-	-	-	-	22	29

C 36003		137.0" Wheelbase					Frame Heights at Minimum Curb Weight							Frame Heights and Angular Dimensions are shown at Maximum GAWR Front/Rear																		
GVW/Tire	Minimum Curb Weight			GAWR		HE	HF	HF (mce)	HG	HM	HR	HS	HS2	HT	HE	HF	HF (mce)	HG	HM	HR	HS	HS2	HT	A	B/mce	C/mce	D	E	F	G	H	I
	Frt	Rr	Ttl	Frt	Rr																											
¹ 11400 LT215/85R16	2978	2429	5407	4500	8550	33.3	13.0	13.2	76.2	20.6	31.8	25.3	-	-	26.9	11.0	11.2	74.4	17.8	27.1	22.4	-	-	17	35/43	25/23	28	-	-	-	23	24

C 36053		161.5" Wheelbase					Frame Heights at Minimum Curb Weight							Frame Heights and Angular Dimensions are shown at Maximum GAWR Front/Rear																		
GVW/Tire	Minimum Curb Weight			GAWR		HE	HF	HF (mce)	HG	HM	HR	HS	HS2	HT	HE	HF	HF (mce)	HG	HM	HR	HS	HS2	HT	A	B/mce	C/mce	D	E	F	G	H	I
	Frt	Rr	Ttl	Frt	Rr																											
¹ 11400 LT215/85R16	3215	2575	5790	4670	8550	32.8	13.1	13.3	76.6	20.3	31.6	25.0	25.6	-	26.8	11.1	11.3	74.6	17.8	27.1	22.4	24.0	-	15	35/44	26/24	28	-	-	-	23	24

NOTE: Front coil springs, torsion bars and adjusters are computer selected based on model options and calculated sprung curb weight. Actual heights may vary due to production tolerances.

1) Base GVWR — contains minimum equipment required

2) Optional GVWR — contains minimum equipment required

(—) = not applicable for this model

FRAME HEIGHT AND RAMP ANGLE DATA

C 36403		161.5" Wheelbase			Frame Heights at Minimum Curb Weight									Frame Heights and Angular Dimensions are shown at Maximum GAWR Front/Rear																		
GVW/Tire	Minimum Curb Weight			GAWR		HE	HF	HF (mce)	HG	HM	HR	HS	HS2	HT	HE	HF	HF (mce)	HG	HM	HR	HS	HS2	HT	A	B/mce	C/mce	D	E	F	G	H	I
	Frnt	Rr	Ttl	Frnt	Rr																											
¹⁾ 11400 LT215/85R16	3118	2368	5486	4670	8550	33.3	13.1	13.2	76.0	20.4	31.9	25.1	-	-	26.8	11.0	11.2	74.5	17.7	27.1	22.3	-	-	15	35/43	25/23	28	-	-	-	23	24

C 36453		185.5" Wheelbase			Frame Heights at Minimum Curb Weight									Frame Heights and Angular Dimensions are shown at Maximum GAWR Front/Rear																		
GVW/Tire	Minimum Curb Weight			GAWR		HE	HF	HF (mce)	HG	HM	HR	HS	HS2	HT	HE	HF	HF (mce)	HG	HM	HR	HS	HS2	HT	A	B/mce	C/mce	D	E	F	G	H	I
	Frnt	Rr	Ttl	Frnt	Rr																											
¹⁾ 11400 LT215/85R16	3358	2518	5876	4800	8550	32.8	13.2	13.4	76.4	20.3	31.7	24.9	25.4	-	26.8	11.3	11.5	74.8	17.8	27.1	22.3	24.2	-	13	36/44	26/24	28	-	-	-	23	24

K 36003		137.0" Wheelbase			Frame Heights at Minimum Curb Weight									Frame Heights and Angular Dimensions are shown at Maximum GAWR Front/Rear																		
GVW/Tire	Minimum Curb Weight			GAWR		HE	HF	HF (mce)	HG	HM	HR	HS	HS2	HT	HE	HF	HF (mce)	HG	HM	HR	HS	HS2	HT	A	B/mce	C/mce	D	E	F	G	H	I
	Frnt	Rr	Ttl	Frnt	Rr																											
¹⁾ 12000 LT215/85R16	3189	2615	5804	4670	8600	32.9	13.0	13.2	76.0	20.5	31.5	25.2	-	-	27.0	11.1	11.2	74.0	17.8	27.1	22.4	-	-	17	35/44	25/24	28	-	-	-	23	24
²⁾ 12000 & VYU LT215/85R16	3199	2622	5821	4800	8600	32.9	13.1	13.3	76.1	20.5	31.5	25.2	-	-	27.0	10.9	11.1	74.1	17.7	27.1	22.3	-	-	17	35/44	25/23	28	-	-	-	23	24

NOTE: Front coil springs, torsion bars and adjusters are computer selected based on model options and calculated sprung curb weight. Actual heights may vary due to production tolerances.

1) Base GVWR — contains minimum equipment required

2) Optional GVWR — contains minimum equipment required

(—) = not applicable for this model

FRAME HEIGHT AND RAMP ANGLE DATA

K 36053		161.5" Wheelbase				Frame Heights at Minimum Curb Weight								Frame Heights and Angular Dimensions are shown at Maximum GAWR Front/Rear																		
GVW/Tire	Minimum Curb Weight			GAWR		HE	HF	HF (mce)	HG	HM	HR	HS	HS2	HT	HE	HF	HF (mce)	HG	HM	HR	HS	HS2	HT	A	B/mce	C/mce	D	E	F	G	H	I
	Frnt	Rr	Ttl	Frnt	Rr																											
¹⁾ 12000 LT215/85R16	3451	2755	6206	4800	8600	32.4	13.2	13.4	76.5	20.3	31.3	24.9	25.4	—	26.9	11.4	11.6	74.3	17.9	27.1	22.5	23.7	—	15	36/44	26/24	28	—	—	—	23	24

K 36403		161.5" Wheelbase				Frame Heights at Minimum Curb Weight								Frame Heights and Angular Dimensions are shown at Maximum GAWR Front/Rear																		
GVW/Tire	Minimum Curb Weight			GAWR		HE	HF	HF (mce)	HG	HM	HR	HS	HS2	HT	HE	HF	HF (mce)	HG	HM	HR	HS	HS2	HT	A	B/mce	C/mce	D	E	F	G	H	I
	Frnt	Rr	Ttl	Frnt	Rr																											
¹⁾ 12000 LT215/85R16	3356	2554	5910	4800	8600	32.8	13.2	13.3	75.9	20.4	31.6	25.0	—	—	27.0	11.2	11.4	73.7	17.8	27.1	22.4	—	—	15	36/44	26/24	28	—	—	—	23	24

K 36453		185.5" Wheelbase				Frame Heights at Minimum Curb Weight								Frame Heights and Angular Dimensions are shown at Maximum GAWR Front/Rear																		
GVW/Tire	Minimum Curb Weight			GAWR		HE	HF	HF (mce)	HG	HM	HR	HS	HS2	HT	HE	HF	HF (mce)	HG	HM	HR	HS	HS2	HT	A	B/mce	C/mce	D	E	F	G	H	I
	Frnt	Rr	Ttl	Frnt	Rr																											
¹⁾ 12000 LT215/85R16	3559	2724	6283	4800	8600	32.3	13.3	13.4	76.2	20.2	31.4	24.8	25.2	—	26.9	11.6	11.8	74.4	18.0	27.1	22.5	23.8	—	13	36/45	26/24	28	—	—	—	23	24

NOTE: Front coil springs, torsion bars and adjusters are computer selected based on model options and calculated sprung curb weight. Actual heights may vary due to production tolerances.

1) Base GVWR — contains minimum equipment required

2) Optional GVWR — contains minimum equipment required

(—) = not applicable for this model

FRAME HEIGHT AND RAMP ANGLE DATA

C/K Truck - Utility

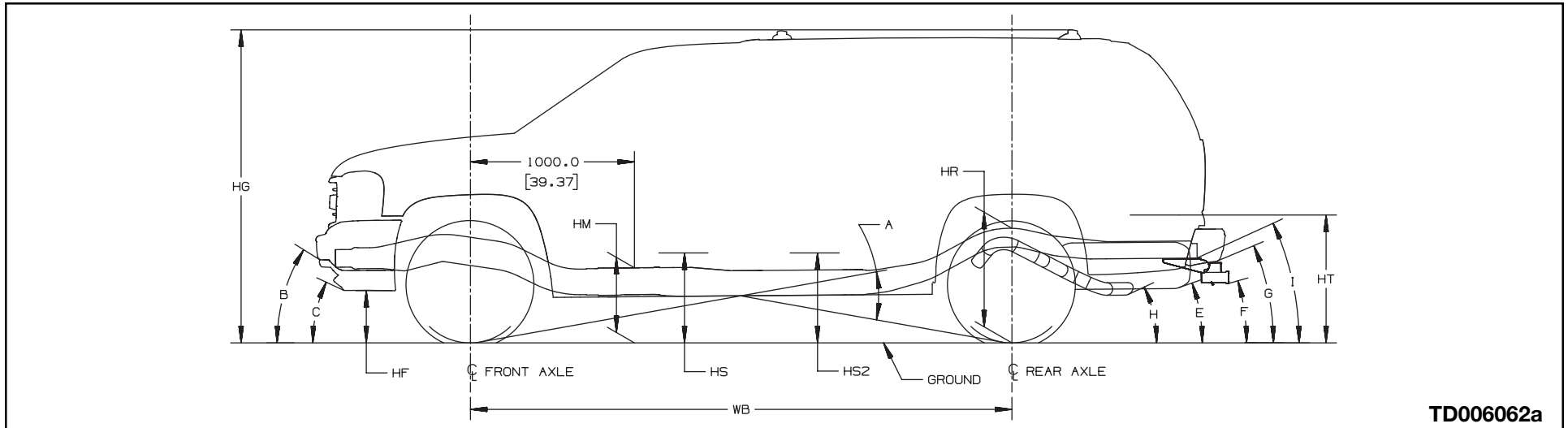

TD006062a

Heights (To Ground)

- HE Top of Frame at End
- HF Bottom of Front Air Deflector or Bumper
- HG Roof height to ground
- HM Normal Top of Frame
- HP Top of Tailgate
- HR Top of Frame at Centerline of Rear Axle
- HS Step H-Point-Front
- HS2 Step H-Point-Second
- HT Rear Cargo Load Height

Angle

- A Ramp Breakover

Approach Angle(s) (Bottom of)

- B Front Bumper
- C Front Air Deflector

Departure Angle(s) (Bottom of)

- D Fuel Tank and Shield
- E Spare Tire
- F Platform Hitch
- G Rear Bumper
- H Exhaust
- I Frame at End

NOTE: All weights are in pounds, dimensions are in inches and angles are in degrees.

FRAME HEIGHT AND RAMP ANGLE DATA

C 15706		116.0" Wheelbase				Frame Heights at Minimum Curb Weight								Frame Heights and Angular Dimensions are shown at Maximum GAWR Front/Rear																		
GVW/Tire	Minimum Curb Weight			GAWR		HE	HF	HG	HM	HP	HR	HS	HS2	HT	HE	HF	HG	HM	HP	HR	HS	HS2	HT	A	B	C	D	E	F	G	H	I
	Frnt	Rr	Ttl	Frnt	Rr																											
¹⁾ 6500 P245/75R16	2537	2381	4918	3200	3750	-	12.6	76.8	18.0	-	28.4	21.8	22.3	31.0	-	10.4	75.0	16.0	-	26.3	19.8	20.6	28.5	22	41	24	-	23	17	30	29	-
²⁾ 6500 P265/70R16	2537	2381	4918	3200	3750	-	12.6	76.9	18.0	-	28.4	21.9	22.3	31	-	10.5	75.1	16.1	-	26.4	19.9	20.7	28.6	23	41	24	-	23	18	30	29	-
²⁾ 6800 P245/75R16	2590	2512	5102	3200	4000	-	12.7	76.5	17.7	-	27.9	21.6	22.0	30.4	-	10.7	74.7	15.9	-	25.6	19.8	20.2	27.6	22	41	24	-	22	16	28	27	-
²⁾ 6800 P265/70R16	2590	2512	5102	3200	4000	-	12.7	76.5	17.8	-	28.0	21.7	22.0	30.5	-	10.8	74.8	16.0	-	25.7	19.8	20.2	27.7	22	42	24	-	22	16	28	27	-
²⁾ 6800 & Z75 P265/70R17	2664	2613	5277	3200	4000	-	14.8	76.6	18.4	-	27.7	22.5	22.3	29.7	-	13.5	75.4	16.3	-	26.3	20.6	21.1	27.9	24	48	30	-	22	17	29	28	-

NOTE: Roof Rack is required on ('06) except W/BPH. Also K15936 w/Z75.

C 15906		130.0" Wheelbase				Frame Heights at Minimum Curb Weight								Frame Heights and Angular Dimensions are shown at Maximum GAWR Front/Rear																		
GVW/Tire	Minimum Curb Weight			GAWR		HE	HF	HG	HM	HP	HR	HS	HS2	HT	HE	HF	HG	HM	HP	HR	HS	HS2	HT	A	B	C	D	E	F	G	H	I
	Frnt	Rr	Ttl	Frnt	Rr																											
¹⁾ 7000 P245/75R16	2638	2337	4975	3200	4000	-	12.5	76.7	18.1	-	28.9	21.9	22.6	31.7	-	11.3	73.7	15.8	-	25.4	19.8	19.9	27.4	20	43	25	-	21	14	24	26	-
²⁾ 7000 P265/70R16	2638	2337	4975	3200	4000	-	12.5	76.8	18.2	-	29.0	21.9	22.6	31.8	-	11.3	73.8	15.9	-	25.5	19.8	19.9	27.5	20	43	26	-	22	14	24	27	-

NOTE: Front coil springs, torsion bars and adjusters are computer selected based on model options and calculated sprung curb weight. Actual heights may vary due to production tolerances.

1) Base GVWR — contains minimum equipment required

2) Optional GVWR — contains minimum equipment required

(—) = not applicable for this model

FRAME HEIGHT AND RAMP ANGLE DATA

K 15706		116.0" Wheelbase				Frame Heights at Minimum Curb Weight								Frame Heights and Angular Dimensions are shown at Maximum GAWR Front/Rear																		
GVW/Tire	Minimum Curb Weight			GAWR		HE	HF	HG	HM	HP	HR	HS	HS2	HT	HE	HF	HG	HM	HP	HR	HS	HS2	HT	A	B	C	D	E	F	G	H	I
	Frt	Rr	Ttl	Frt	Rr																											
¹⁾ 6800 P245/75R16	2730	2423	5153	3600	3750	-	12.5	76.7	17.9	-	28.3	21.7	22.2	30.9	-	9.7	75.0	15.9	-	26.3	19.5	20.5	28.6	22	39	22	-	23	18	30	29	-
²⁾ 6800 P265/70R16	2730	2423	5153	3600	3750	-	12.6	76.8	17.9	-	28.3	21.8	22.2	30.9	-	9.7	75.1	15.9	-	26.4	19.6	20.6	28.7	22	40	23	-	23	18	30	29	-
²⁾ 6800 LT245/75R16	2730	2423	5153	3600	3750	-	12.8	77.0	18.1	-	28.5	21.9	22.4	31.1	-	10.0	75.3	16.2	-	26.7	19.8	20.8	29.0	22	40	22	-	23	18	30	29	-
²⁾ 6800 P265/75R16	2730	2423	5153	3600	3750	-	13.2	77.4	18.5	-	28.9	22.4	22.8	31.5	-	10.3	75.7	16.5	-	27.0	20.2	21.2	29.3	23	41	24	-	24	18	31	30	-
²⁾ 6800 LT265/75R16	2730	2423	5153	3600	3750	-	13.6	77.9	19.0	-	29.4	22.8	23.3	32.0	-	10.8	76.2	17.0	-	27.5	20.7	21.7	29.9	23	41	24	-	24	19	31	31	-
²⁾ 6800 P265/70R17	2730	2423	5153	3350	3900	-	13.0	77.3	18.4	-	28.8	22.2	22.7	31.4	-	11.0	75.7	16.7	-	26.6	20.5	21.0	28.7	24	43	25	-	24	18	30	30	-
²⁾ 6900 P245/75R16	2786	2555	5341	3600	4000	-	12.6	76.4	17.6	-	27.8	21.5	21.9	30.3	-	9.8	75.0	15.9	-	25.6	19.6	20.2	27.6	22	40	23	-	22	16	28	27	-
²⁾ 6900 P265/70R16	2786	2555	5341	3600	4000	-	12.7	76.4	17.7	-	27.9	21.6	21.9	30.4	-	9.9	75.1	16.0	-	25.7	19.7	20.3	27.6	22	40	23	-	22	16	28	27	-
²⁾ 6900 LT265/75R16	2786	2555	5341	3600	4000	-	13.7	77.5	18.8	-	29.0	22.6	23.0	31.5	-	11.0	76.2	17.1	-	26.9	20.8	21.4	28.8	24	42	24	-	23	17	29	28	-
²⁾ 6900 P265/75R16	2786	2555	5341	3600	4000	-	13.3	77.0	18.3	-	28.5	22.2	22.5	31.0	-	10.5	75.7	16.6	-	26.7	20.3	21.1	28.7	24	42	24	-	23	18	30	29	-
²⁾ 6900 LT245/75R16	2786	2555	5341	3550	4000	-	12.9	76.6	17.9	-	28.1	21.8	22.1	30.5	-	10.2	75.3	16.2	-	26.3	19.9	20.8	28.4	22	40	23	-	22	17	29	28	-
²⁾ 7000 P265/70R17	2864	2642	5506	3550	4000	-	13.0	77.3	18.4	-	28.9	22.2	22.7	31.5	-	10.7	76	16.8	-	27.3	20.5	21.5	29.6	24	42	25	-	25	19	32	32	-

NOTE: Rack is required on (06) except w/BPH and K15936 & Z75.

↑ Column "A" is ramp angle 2001 model year.

NOTE: Front coil springs, torsion bars and adjusters are computer selected based on model options and calculated sprung curb weight. Actual heights may vary due to production tolerances.

1) Base GVWR — contains minimum equipment required

2) Optional GVWR — contains minimum equipment required

(-) = not applicable for this model

FRAME HEIGHT AND RAMP ANGLE DATA

K 15906		130.0" Wheelbase				Frame Heights at Minimum Curb Weight							Frame Heights and Angular Dimensions are shown at Maximum GAWR Front/Rear																			
GVW/Tire	Minimum Curb Weight			GAWR		HE	HF	HG	HM	HP	HR	HS	HS2	HT	HE	HF	HG	HM	HP	HR	HS	HS2	HT	A	B	C	D	E	F	G	H	I
	Fr	Rr	Ttl	Fr	Rr																											
¹⁾ 7200 P245/75R16	2841	2378	5219	3600	4000	-	12.4	76.7	18.0	-	28.9	21.8	22.5	31.7	-	10.5	74.0	15.8	-	25.4	19.6	19.9	27.4	20	41	24	-	21	14	24	26	-
²⁾ 7200 P265/70R16	2841	2378	5219	3600	4000	-	12.5	76.7	18.1	-	28.9	21.9	22.6	31.7	-	10.6	74.0	15.8	-	25.5	19.7	19.9	27.5	20	42	24	-	22	14	24	27	-
²⁾ 7200 P265/70R17	2841	2378	5219	3550	4000	-	12.9	77.1	18.5	-	29.3	22.3	23.0	32.1	-	11.2	74.4	16.2	-	25.9	20.1	20.3	27.9	21	43	26	-	22	15	24	28	-
²⁾ 7200 P265/70R17	2841	2378	5219	3450	4000	-	12.9	77.2	18.6	-	29.4	22.4	23.1	32.2	-	11.6	74.4	16.3	-	26.0	20.3	20.4	28.0	21	44	26	-	23	15	25	28	-

C 25906		130.0" Wheelbase				Frame Heights at Minimum Curb Weight							Frame Heights and Angular Dimensions are shown at Maximum GAWR Front/Rear																			
GVW/Tire	Minimum Curb Weight			GAWR		HE	HF	HG	HM	HP	HR	HS	HS2	HT	HE	HF	HG	HM	HP	HR	HS	HS2	HT	A	B	C	D	E	F	G	H	I
	Fr	Rr	Ttl	Fr	Rr																											
¹⁾ 8600 LT245/75R16	2858	2595	5453	3800	5500	-	13.3	77.8	20.8	-	28.9	22.8	23.6	32.8	-	12.0	75.5	18.9	-	26.2	21.1	21.6	29.4	21	44	26	-	20	16	25	30	-
¹⁾ 8600 & NYS LT245/75R16	2947	3046	5993	3800	5500	-	13.3	77.8	20.8	-	28.9	22.8	23.6	32.9	-	12.1	75.5	19.0	-	26.1	21.2	21.6	29.3	21	44	27	-	20	16	25	30	-

NOTE: Roof rack is required on (06) except w/BPH. Also K15936 w/Z75.

NOTE: Front coil springs, torsion bars and adjusters are computer selected based on model options and calculated sprung curb weight. Actual heights may vary due to production tolerances.

1) Base GVWR — contains minimum equipment required

2) Optional GVWR — contains minimum equipment required

(-) = not applicable for this model

FRAME HEIGHT AND RAMP ANGLE DATA

K 25906		130.0" Wheelbase				Frame Heights at Minimum Curb Weight								Frame Heights and Angular Dimensions are shown at Maximum GAWR Front/Rear																		
GVW/Tire	Minimum Curb Weight			GAWR		HE	HF	HG	HM	HP	HR	HS	HS2	HT	HE	HF	HG	HM	HP	HR	HS	HS2	HT	A	B	C	D	E	F	G	H	I
	Frnt	Rr	Ttl	Frnt	Rr																											
¹⁾ 8600 LT245/75R16	3126	2649	5775	4180	5500	-	13.2	77.7	20.7	-	28.8	22.7	23.5	32.8	-	11.6	75.9	18.9	-	26.2	21.0	21.7	29.3	21	43	26	-	20	16	25	30	-
¹⁾ 8600 & NYS LT245/75R16	3207	3098	6305	4180	5600	-	13.2	77.8	20.7	-	28.8	22.7	23.5	32.8	-	11.7	76.0	19.1	-	26.1	21.1	21.7	29.0	21	43	26	-	19	15	25	30	-

NOTE: Rack is required on (06) except w/BPH and K15936 & Z75.

NOTE: Front coil springs, torsion bars and adjusters are computer selected based on model options and calculated sprung curb weight. Actual heights may vary due to production tolerances.

1) Base GVWR — contains minimum equipment required

2) Optional GVWR — contains minimum equipment required

(—) = not applicable for this model

FRAME HEIGHT AND RAMP ANGLE DATA

C/K Truck - Avalanche

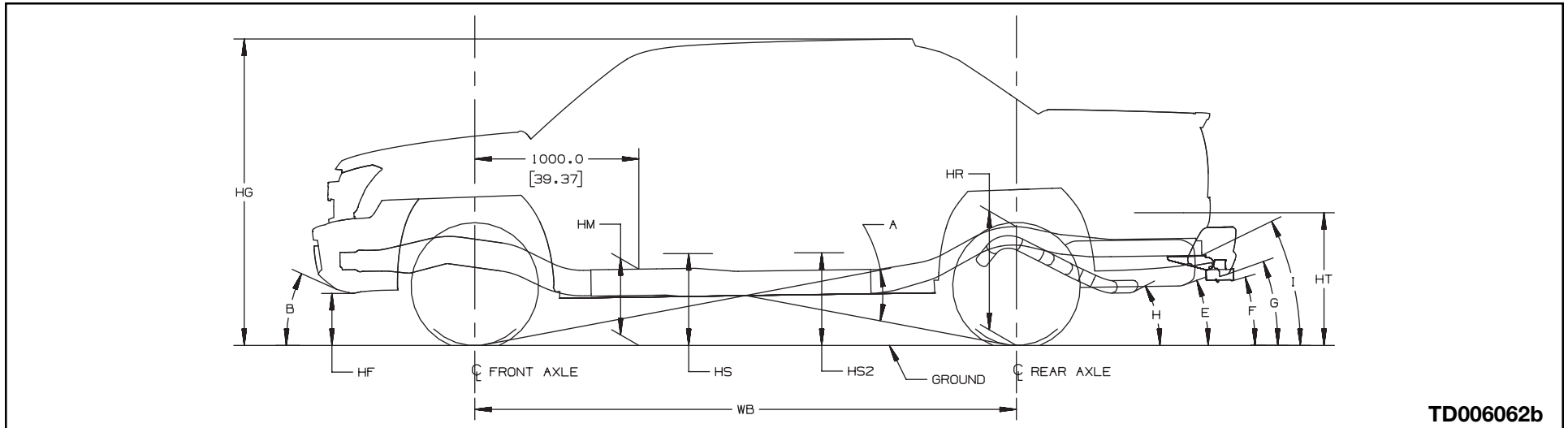

TD006062b

Heights (To Ground)

- HE Top of Frame at End
- HF Bottom of Front Air Deflector or Bumper
- HG Roof height to ground
- HM Normal Top of Frame
- HP Top of Tailgate
- HR Top of Frame at Centerline of Rear Axle
- HS Step H-Point-Front
- HS2 Step H-Point-Second
- HT Rear Cargo Load Height

Angle

- A Ramp Breakover

Approach Angle(s) (Bottom of)

- B Front Bumper
- C Front Air Deflector

Departure Angle(s) (Bottom of)

- D Fuel Tank and Shield
- E Spare Tire
- F Platform Hitch
- G Rear Bumper
- H Exhaust
- I Frame at End

NOTE: All weights are in pounds, dimensions are in inches and angles are in degrees.

FRAME HEIGHT AND RAMP ANGLE DATA

C 15936		130.0" Wheelbase				Frame Heights at Minimum Curb Weight								Frame Heights and Angular Dimensions are shown at Maximum GAWR Front/Rear																		
GVW/Tire	Minimum Curb Weight			GAWR		HE	HF	HG	HM	HP	HR	HS	HS2	HT	HE	HF	HG	HM	HP	HR	HS	HS2	HT	A	B	C	D	E	F	G	H	I
	Frt	Rr	Ttl	Frt	Rr																											
¹⁾ 6800 P265/70R16	2800	2620	5420	3400	4000	-	12.0	73.8	17.8	-	28.3	21.7	22.2	32.3	-	10.5	72.2	16.2	-	25.3	20.1	20.2	28.3	21	27	-	-	21	13	22	26	-
²⁾ 6800 P265/70R17	2800	2620	5420	3400	4000	-	12.6	73.8	18.0	-	28.2	21.9	22.2	32.0	-	10.8	72.9	16.8	-	26.9	20.6	21.4	30.2	22	28	-	-	24	16	25	31	-

K 15936		130.0" Wheelbase				Frame Heights at Minimum Curb Weight								Frame Heights and Angular Dimensions are shown at Maximum GAWR Front/Rear																		
GVW/Tire	Minimum Curb Weight			GAWR		HE	HF	HG	HM	HP	HR	HS	HS2	HT	HE	HF	HG	HM	HP	HR	HS	HS2	HT	A	B	C	D	E	F	G	H	I
	Frt	Rr	Ttl	Frt	Rr																											
¹⁾ 7000 P265/70R16	3046	2745	5791	3800	4000	-	12.0	73.7	17.7	-	28.2	21.6	22.1	32.2	-	9.8	72.4	16.2	-	25.3	19.9	20.2	28.3	21	26	-	-	21	13	22	26	-
²⁾ 7000 P265/70R17	3048	2747	5795	3800	4000	-	12.4	74.1	18.1	-	28.6	22.0	22.5	32.6	-	10.2	72.8	16.6	-	25.7	20.3	20.6	28.7	22	27	-	-	22	14	23	28	-
²⁾ 7000 & Z75 P265/70R17	3085	2786	5871	3800	4000	-	12.8	75.7	17.6	-	27.6	21.7	21.8	31.2	-	10.5	75.2	16.4	-	26.9	20.2	21.4	30.2	21	23	-	-	24	16	20	31	-

NOTE: Rack is required on (06) except w/BPH and K15936 & Z75.

NOTE: Front coil springs, torsion bars and adjusters are computer selected based on model options and calculated sprung curb weight. Actual heights may vary due to production tolerances.

1) Base GVWR — contains minimum equipment required

2) Optional GVWR — contains minimum equipment required

(-) = not applicable for this model

FRAME HEIGHT AND RAMP ANGLE DATA

C 25936		130.0" Wheelbase			Frame Heights at Minimum Curb Weight									Frame Heights and Angular Dimensions are shown at Maximum GAWR Front/Rear																		
GVW/Tire	Minimum Curb Weight			GAWR		HE	HF	HG	HM	HP	HR	HS	HS2	HT	HE	HF	HG	HM	HP	HR	HS	HS2	HT	A	B	C	D	E	F	G	H	I
	Frt	Rr	Ttl	Frt	Rr																											
¹⁾ 8600 LT245/75R16	2831	2598	5429	4000	5500	-	12.9	74.6	20.2	-	28.0	22.5	23.0	33.1	-	11.9	72.9	18.8	-	25.4	21.1	21.4	29.6	21	30	26	-	18	14	23	30	-

K 25936		130.0" Wheelbase			Frame Heights at Minimum Curb Weight									Frame Heights and Angular Dimensions are shown at Maximum GAWR Front/Rear																		
GVW/Tire	Minimum Curb Weight			GAWR		HE	HF	HG	HM	HP	HR	HS	HS2	HT	HE	HF	HG	HM	HP	HR	HS	HS2	HT	A	B	C	D	E	F	G	H	I
	Frt	Rr	Ttl	Frt	Rr																											
¹⁾ 8600 LT245/75R16	3576	3268	6844	4380	5500	-	12.8	74.4	20.0	-	27.8	22.3	22.8	32.9	-	11.5	73.1	18.8	-	25.4	21.1	21.4	29.4	21	29	-	-	18	14	23	30	-

NOTE: Front coil springs, torsion bars and adjusters are computer selected based on model options and calculated sprung curb weight. Actual heights may vary due to production tolerances.

1) Base GVWR — contains minimum equipment required

2) Optional GVWR — contains minimum equipment required

(—) = not applicable for this model

FRAME HEIGHT AND RAMP ANGLE DATA

H2 HUMMER

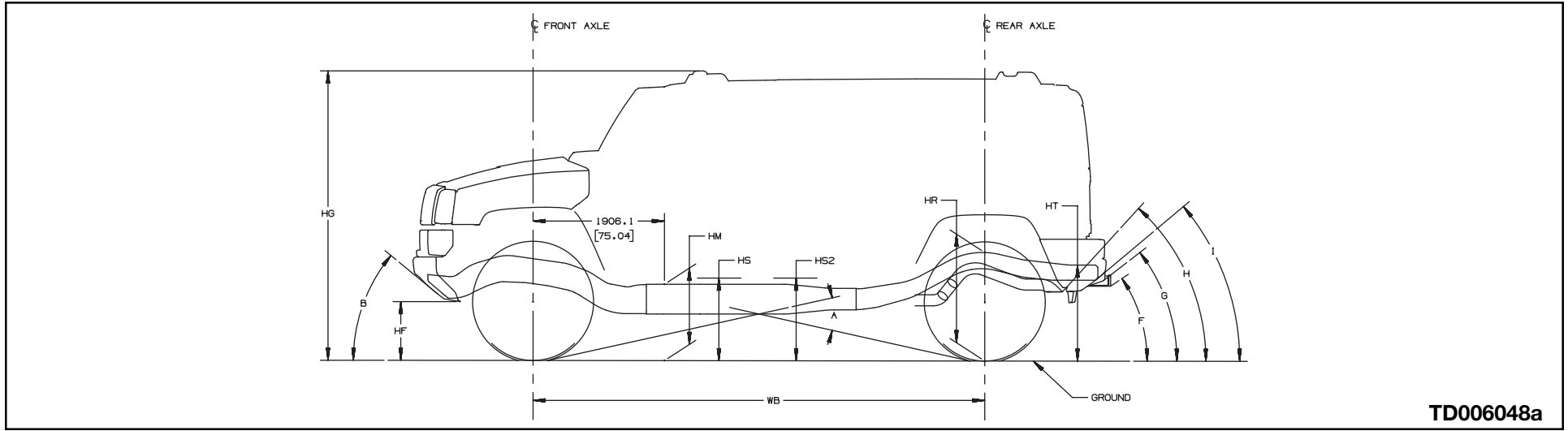

TD006048a

Heights (To Ground)

- HF Bottom of Front Bumper
- HG Top of Roof
- HS Step H-Point-Front
- HS2 Step H-Point-Second
- HT Rear Cargo Load Height

Angle

- A Ramp Breakover

Approach Angle(s) (Bottom of)

- B Air Dam

Departure Angle(s) (Bottom of)

- C Tail pipe
- D Spare Tire
- E Hitch
- F Rear Bumper

NOTE: All weights are in pounds, dimensions are in inches and angles are in degrees.

FRAME HEIGHT AND RAMP ANGLE DATA

N25706		000.0" Wheelbase				Frame Heights at Minimum Curb Weight							Frame Heights and Angular Dimensions are shown at Maximum GAWR Front/Rear																			
GVW/Tire	Minimum Curb Weight			GAWR		HE	HF	HG	HM	HP	HR	HS	HS2	HT	HE	HF	HG	HM	HP	HR	HS	HS2	HT	A	B	C	D	E	F	G	H	I
	Frt	Rr	Ttl	Frt	Rr																											
¹⁾ 0000 P000/00R00	1111								-										-													

NOTE: Front coil springs, torsion bars and adjusters are computer selected based on model options and calculated sprung curb weight. Actual heights may vary due to production tolerances.

1) Base GVWR — contains minimum equipment required

2) Optional GVWR — contains minimum equipment required

(—) = not applicable for this model

FRAME HEIGHT AND RAMP ANGLE DATA

M/L 110(05, 06)

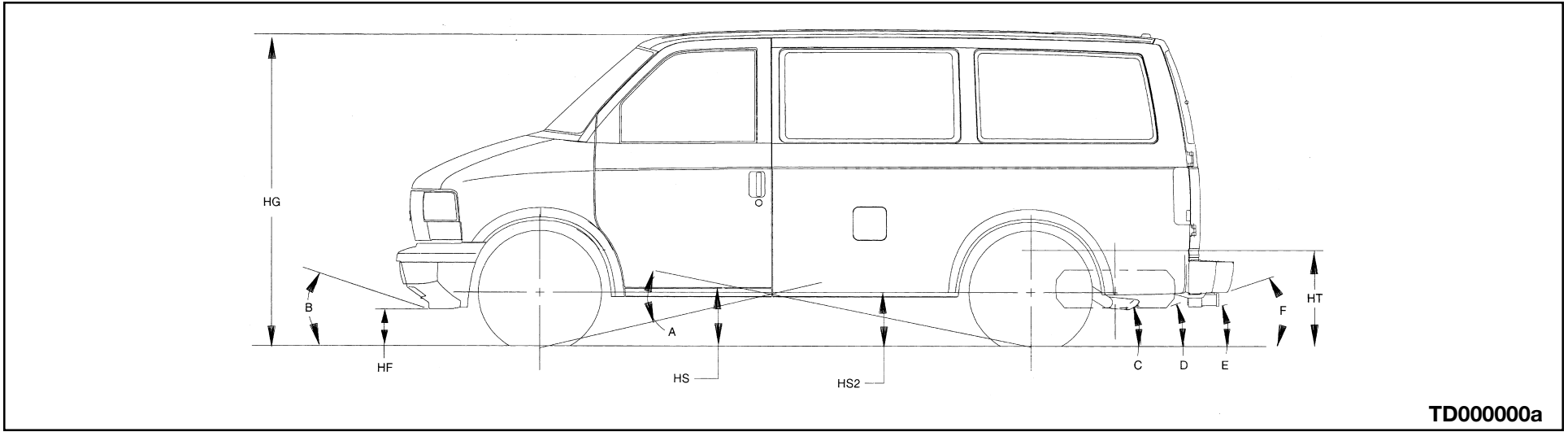

TD000000a

Heights (To Ground)

- HF Bottom of Front Bumper
- HG Top of Roof
- HS Step H-Point-Front
- HS2 Step H-Point-Second
- HT Rear Cargo Load Height

Angle

- A Ramp Breakover

Approach Angle(s) (Bottom of)

- B Air Dam

Departure Angle(s) (Bottom of)

- C Tail pipe
- D Spare Tire
- E Hitch
- F Rear Bumper

NOTE: All weights are in pounds, dimensions are in inches and angles are in degrees.

FRAME HEIGHT AND RAMP ANGLE DATA

M 11005		111.2" Wheelbase				Frame Heights at Minimum Curb Weight							Frame Heights and Angular Dimensions are shown at Maximum GAWR Front/Rear																			
GVW/Tire	Minimum Curb Weight			GAWR		HE	HF	HG	HM	HP	HR	HS	HS2	HT	HE	HF	HG	HM	HP	HR	HS	HS2	HT	A	B	C	D	E	F	G	H	I
	Frnt	Rr	Ttl	Frnt	Rr																											
¹⁾ 5600 P215/70R16	2339	1616	3955	2800	3100	-	9.2	75.9	-	-	-	19.2	21.2	27.7	-	8.5	73.2	-	-	-	17.2	18.2	22.4	29	24	18	19	15	19	-	-	-
²⁾ 5900 P215/70R16	2344	1583	3927	2800	3100	-	9.4	76.0	-	-	-	19.3	21.3	27.8	-	8.7	72.6	-	-	-	16.9	18.0	22.6	29	25	18	19	15	19	-	-	-

M 11006		111.2" Wheelbase				Frame Heights at Minimum Curb Weight							Frame Heights and Angular Dimensions are shown at Maximum GAWR Front/Rear																			
GVW/Tire	Minimum Curb Weight			GAWR		HE	HF	HG	HM	HP	HR	HS	HS2	HT	HE	HF	HG	HM	HP	HR	HS	HS2	HT	A	B	C	D	E	F	G	H	I
	Frnt	Rr	Ttl	Frnt	Rr																											
¹⁾ 5900 P215/70R16	2352	2021	4373	2800	3100	-	9.5	75.0	-	-	-	18.7	20.3	26.0	-	8.5	72.5	-	-	-	16.7	17.8	22.5	28	24	18	19	15	19	-	-	-

NOTE: Front coil springs, torsion bars and adjusters are computer selected based on model options and calculated sprung curb weight. Actual heights may vary due to production tolerances.

1) Base GVWR — contains minimum equipment required

2) Optional GVWR — contains minimum equipment required

(—) = not applicable for this model

FRAME HEIGHT AND RAMP ANGLE DATA

L 11005		111.2" Wheelbase				Frame Heights at Minimum Curb Weight							Frame Heights and Angular Dimensions are shown at Maximum GAWR Front/Rear																			
GVW/Tire	Minimum Curb Weight			GAWR		HE	HF	HG	HM	HP	HR	HS	HS2	HT	HE	HF	HG	HM	HP	HR	HS	HS2	HT	A	B	C	D	E	F	G	H	I
	Frt	Rr	Ttl	Frt	Rr																											
¹⁾ 5850 P215/70R16	2559	1683	4242	3050	3100	-	9.6	75.7	-	-	-	19.2	21.0	27.2	-	8.7	73.2	-	-	-	17.2	18.2	22.2	29	25	17	18	15	18	-	-	-
²⁾ 6050 P215/70R16	2563	1649	4212	3050	3100	-	9.6	75.8	-	-	-	19.2	21.1	27.3	-	8.8	72.8	-	-	-	17.0	18.0	22.3	29	26	18	19	15	19	-	-	-

L 11006		111.2" Wheelbase				Frame Heights at Minimum Curb Weight							Frame Heights and Angular Dimensions are shown at Maximum GAWR Front/Rear																			
GVW/Tire	Minimum Curb Weight			GAWR		HE	HF	HG	HM	HP	HR	HS	HS2	HT	HE	HF	HG	HM	HP	HR	HS	HS2	HT	A	B	C	D	E	F	G	H	I
	Frt	Rr	Ttl	Frt	Rr																											
¹⁾ 6100 P215/70R16	2565	2034	4599	3050	3100	-	9.5	75.0	-	-	-	18.7	20.3	26.1	-	8.6	72.7	-	-	-	16.9	18.0	22.6	29	25	18	19	15	19	-	-	-

NOTE: Front coil springs, torsion bars and adjusters are computer selected based on model options and calculated sprung curb weight. Actual heights may vary due to production tolerances.

1) Base GVWR — contains minimum equipment required

2) Optional GVWR — contains minimum equipment required

(—) = not applicable for this model

FRAME HEIGHT AND RAMP ANGLE DATA

G/H Van - Full Body

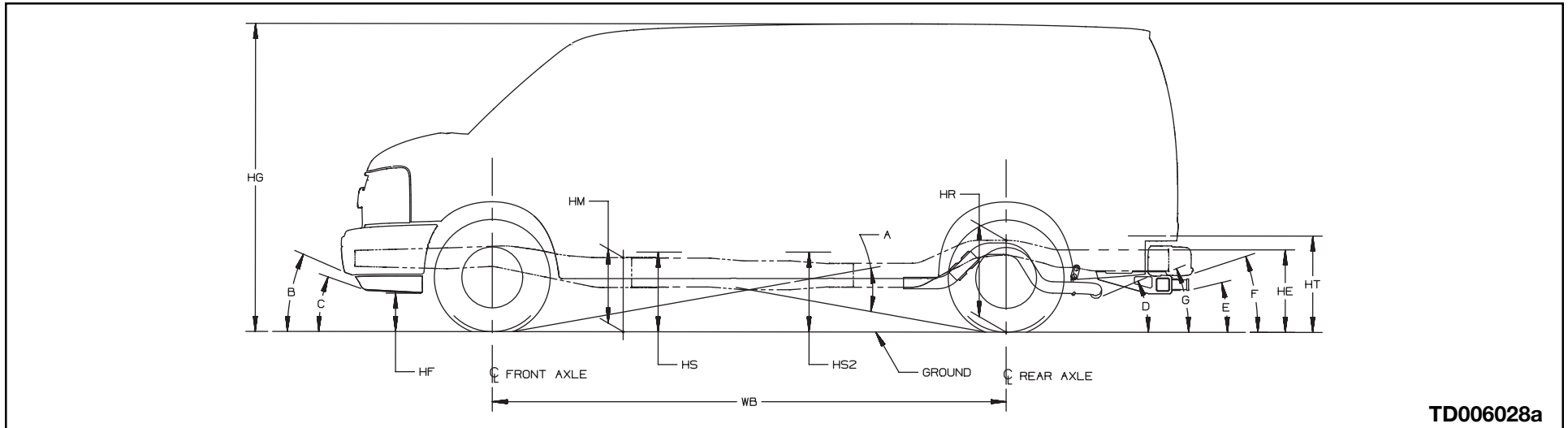

TD006028a

Heights (To Ground)

- HE Top of Frame at End
- HF Bottom of Front Air Deflector or Bumper
- HG Roof Height
- HM Normal Top of Frame
- HR Top of Frame at Centerline of Rear Axle
- HS Step H-Point-Front
- HS2 Step H-Point-Second
- HT Rear Cargo Load Height

Angle

- A Ramp Breakover

Approach Angle(s) (Bottom of)

- B Front Air Deflector
- C Air Dam

Departure Angle(s) (Bottom of)

- D Tail pipe
- E Platform Hitch
- F Rear Bumper
- G Frame at End

NOTE: All weights are in pounds, dimensions are in inches and angles are in degrees.

FRAME HEIGHT AND RAMP ANGLE DATA

G 13405		135.0" Wheelbase				Frame Heights at Minimum Curb Weight							Frame Heights and Angular Dimensions are shown at Maximum GAWR Front/Rear																			
GVW/Tire	Minimum Curb Weight			GAWR		HE	HF	HG	HM	HR	HS	HS2	HS (LH)	HT	HE	HF	HG	HM	HR	HS	HS2	HS (LH)	HT	A	B	C	D	E	F	G	H	I
	Frt	Rr	Ttl	Frt	Rr																											
¹⁾ 6200 P235/75R16	2920	1898	4818	3300	3200	-	14.8	81.0	17.3	24.5	17.5	18.2	20.3	26.0	-	14.3	79.5	16.3	22.2	16.5	16.8	18.9	23.1	20	30	23	21	12	18	-	-	-
²⁾ 7200 P235/75R16	2876	1773	4649	3600	4000	-	14.8	82.3	17.8	25.8	18.1	19.1	21.2	27.6	-	13.9	79.2	15.9	21.9	16.1	16.5	18.6	22.8	19	29	22	21	12	17	-	-	-

G 13406		135.0" Wheelbase				Frame Heights at Minimum Curb Weight							Frame Heights and Angular Dimensions are shown at Maximum GAWR Front/Rear																			
GVW/Tire	Minimum Curb Weight			GAWR		HE	HF	HG	HM	HR	HS	HS2	HS (LH)	HT	HE	HF	HG	HM	HR	HS	HS2	HS (LH)	HT	A	B	C	D	E	F	G	H	I
	Frt	Rr	Ttl	Frt	Rr																											
¹⁾ 7200 P235/75R16	2733	2478	5211	3600	4000	-	15.3	81.1	17.6	24.4	17.8	18.4	20.4	25.8	-	13.7	79.1	15.8	21.9	16.0	16.4	18.5	22.8	19	29	22	21	12	17	-	-	-

H 13405		135.0" Wheelbase				Frame Heights at Minimum Curb Weight							Frame Heights and Angular Dimensions are shown at Maximum GAWR Front/Rear																			
GVW/Tire	Minimum Curb Weight			GAWR		HE	HF	HG	HM	HR	HS	HS2	HS (LH)	HT	HE	HF	HG	HM	HR	HS	HS2	HS (LH)	HT	A	B	C	D	E	F	G	H	I
	Frt	Rr	Ttl	Frt	Rr																											
¹⁾ 7200 P235/75R16	2887	2068	4955	3600	4000	-	14.9	81.7	17.6	25.2	17.9	18.8	20.9	26.9	-	13.8	79.2	15.9	21.9	16.1	16.5	18.6	22.8	19	29	22	21	12	17	-	-	-

NOTE: Front coil springs, torsion bars and adjusters are computer selected based on model options and calculated sprung curb weight. Actual heights may vary due to production tolerances.

1) Base GVWR — contains minimum equipment required

2) Optional GVWR — contains minimum equipment required

(—) = not applicable for this model

FRAME HEIGHT AND RAMP ANGLE DATA

H 13406		135.0" Wheelbase				Frame Heights at Minimum Curb Weight								Frame Heights and Angular Dimensions are shown at Maximum GAWR Front/Rear																		
GVW/Tire	Minimum Curb Weight			GAWR		HE	HF	HG	HM	HR	HS	HS2	HS (LH)	HT	HE	HF	HG	HM	HR	HS	HS2	HS (LH)	HT	A	B	C	D	E	F	G	H	I
	Frt	Rr	Ttl	Frt	Rr																											
¹⁾ 7200 P235/75R16	2635	2380	5015	3600	3968	-	15.0	81.0	17.4	24.5	17.6	18.3	20.4	26.0	-	14.1	79.2	16.0	21.9	16.2	16.5	18.7	22.7	20	30	23	21	12	17	-	-	-

G 23405		135.0" Wheelbase				Frame Heights at Minimum Curb Weight								Frame Heights and Angular Dimensions are shown at Maximum GAWR Front/Rear																		
GVW/Tire	Minimum Curb Weight			GAWR		HE	HF	HG	HM	HR	HS	HS2	HS (LH)	HT	HE	HF	HG	HM	HR	HS	HS2	HS (LH)	HT	A	B	C	D	E	F	G	H	I
	Frt	Rr	Ttl	Frt	Rr																											
¹⁾ 7300 LT245/75R16	2663	2269	4932	3600	4380	-	15.7	82.9	18.6	26.4	18.8	19.9	21.9	28.2	-	14.1	80.3	16.6	22.9	16.8	17.5	19.6	23.8	20	29	22	23	13	18	-	-	-
²⁾ 8500 & KL6 LT245/75R16	2876	2336	5212	4100	5360	-	17.3	83.8	19.9	27.3	20.2	21.0	23.1	28.9	-	15.2	81.6	17.7	24.4	18.0	18.9	20.9	25.2	22	31	24	26	15	20	-	-	-
²⁾ 8600 LT225/75R16	2778	2985	5763	4100	5360	-	17.3	82.5	19.2	25.7	19.4	19.8	21.9	26.9	-	14.7	80.9	17.2	23.8	17.4	18.3	20.2	24.7	21	30	23	25	14	19	-	-	-

NOTE: Front coil springs, torsion bars and adjusters are computer selected based on model options and calculated sprung curb weight. Actual heights may vary due to production tolerances.

1) Base GVWR — contains minimum equipment required

2) Optional GVWR — contains minimum equipment required

(—) = not applicable for this model

FRAME HEIGHT AND RAMP ANGLE DATA

G 23406		135.0" Wheelbase					Frame Heights at Minimum Curb Weight							Frame Heights and Angular Dimensions are shown at Maximum GAWR Front/Rear																		
GVW/Tire	Minimum Curb Weight			GAWR		HE	HF	HG	HM	HR	HS	HS2	HS (LH)	HT	HE	HF	HG	HM	HR	HS	HS2	HS (LH)	HT	A	B	C	D	E	F	G	H	I
	Frnt	Rr	Ttl	Frnt	Rr																											
²⁾ 8500 & KL6 LT245/75R16	3029	2607	5636	4100	5360	-	17.1	83.3	19.6	26.9	19.8	20.6	22.7	28.4	-	15.2	81.6	17.7	24.4	18.0	18.9	20.9	25.2	22	31	24	26	15	20	-	-	-
¹⁾ 8600 LT225/75R16	2925	3110	6035	4100	5360	-	17.0	82.3	19.0	25.6	19.2	19.7	21.7	26.9	-	14.7	80.9	17.2	23.8	17.4	18.3	20.2	24.7	21	30	23	25	14	19	-	-	-

G 23705		155.0" Wheelbase					Frame Heights at Minimum Curb Weight							Frame Heights and Angular Dimensions are shown at Maximum GAWR Front/Rear																		
GVW/Tire	Minimum Curb Weight			GAWR		HE	HF	HG	HM	HP	HR	HS	HS2	HT	HE	HF	HG	HM	HP	HR	HS	HS2	HT	A	B	C	D	E	F	G	H	I
	Frnt	Rr	Ttl	Frnt	Rr																											
¹⁾ 7300 LT245/75R16	2889	2139	5028	3600	4380	-	15.4	83.2	18.4	-	26.7	18.6	19.7	28.5	-	14.4	80.4	16.7	-	22.9	16.9	17.6	23.8	18	29	22	23	13	18	-	-	-
²⁾ 8500 & KL6 LT245/75R16	3113	2196	5309	4300	5360	-	17.0	84.0	19.7	-	27.6	19.9	20.8	29.2	-	15.0	81.7	17.6	-	24.3	17.9	19.1	25.2	19	31	24	26	14	20	-	-	-
²⁾ 8600 LT225/75R16	3077	2146	5223	4300	5360	-	16.6	83.5	19.3	-	27.1	19.5	20.4	28.7	-	14.6	81.0	17.1	-	23.8	17.3	18.4	24.6	18	30	23	25	14	19	-	-	-

G 23706		155.0" Wheelbase					Frame Heights at Minimum Curb Weight							Frame Heights and Angular Dimensions are shown at Maximum GAWR Front/Rear																		
GVW/Tire	Minimum Curb Weight			GAWR		HE	HF	HG	HM	HP	HR	HS	HS2	HT	HE	HF	HG	HM	HP	HR	HS	HS2	HT	A	B	C	D	E	F	G	H	I
	Frnt	Rr	Ttl	Frnt	Rr																											
¹⁾ 8600 LT225/75R16	3306	2585	5891	4100	5360	-	16.5	82.8	18.9	-	26.3	19.2	19.9	27.8	-	15.3	81.1	17.5	-	23.8	17.7	18.5	24.6	19	31	24	24	14	19	-	-	-

NOTE: Front coil springs, torsion bars and adjusters are computer selected based on model options and calculated sprung curb weight. Actual heights may vary due to production tolerances.

1) Base GVWR — contains minimum equipment required

2) Optional GVWR — contains minimum equipment required

(-) = not applicable for this model

FRAME HEIGHT AND RAMP ANGLE DATA

H 23405		135.0" Wheelbase				Frame Heights at Minimum Curb Weight							Frame Heights and Angular Dimensions are shown at Maximum GAWR Front/Rear																			
GVW/Tire	Minimum Curb Weight			GAWR		HE	HF	HG	HM	HR	HS	HS2	HS (LH)	HT	HE	HF	HG	HM	HR	HS	HS2	HS (LH)	HT	A	B	C	D	E	F	G	H	I
	Frt	Rr	Ttl	Frt	Rr																											
¹⁾ 7300 LT245/75R16	2635	2380	5015	3600	3968	-	15.5	82.7	18.4	26.2	18.6	19.6	21.7	28.0	-	14.3	80.3	16.7	22.9	16.9	17.5	19.7	23.7	20	29	22	23	13	18	-	-	-

G 33405		135.0" Wheelbase				Frame Heights at Minimum Curb Weight							Frame Heights and Angular Dimensions are shown at Maximum GAWR Front/Rear																			
GVW/Tire	Minimum Curb Weight			GAWR		HE	HF	HG	HM	HR	HS	HS2	HS (LH)	HT	HE	HF	HG	HM	HR	HS	HS2	HS (LH)	HT	A	B	C	D	E	F	G	H	I
	Frt	Rr	Ttl	Frt	Rr																											
¹⁾ 9600 LT245/75R16	2901	2311	5212	4300	6084	-	17.4	84.1	20.0	27.7	20.3	21.2	23.3	29.3	-	15.1	81.3	17.5	24.3	17.8	18.7	20.7	25.3	22	31	24	27	15	20	-	-	-

G 33406		135.0" Wheelbase				Frame Heights at Minimum Curb Weight							Frame Heights and Angular Dimensions are shown at Maximum GAWR Front/Rear																			
GVW/Tire	Minimum Curb Weight			GAWR		HE	HF	HG	HM	HR	HS	HS2	HS (LH)	HT	HE	HF	HG	HM	HR	HS	HS2	HS (LH)	HT	A	B	C	D	E	F	G	H	I
	Frt	Rr	Ttl	Frt	Rr																											
¹⁾ 9600 LT245/75R16	3044	2593	5637	4300	6084	-	17.2	83.6	19.7	27.2	20.0	20.9	22.9	28.8	-	15.1	81.3	17.5	24.3	17.8	18.7	20.7	25.3	22	31	24	27	15	20	-	-	-

NOTE: Front coil springs, torsion bars and adjusters are computer selected based on model options and calculated sprung curb weight. Actual heights may vary due to production tolerances.

1) Base GVWR — contains minimum equipment required

2) Optional GVWR — contains minimum equipment required

(—) = not applicable for this model

FRAME HEIGHT AND RAMP ANGLE DATA

G 33705		155.0" Wheelbase				Frame Heights at Minimum Curb Weight								Frame Heights and Angular Dimensions are shown at Maximum GAWR Front/Rear																		
GVW/Tire	Minimum Curb Weight			GAWR		HE	HF	HG	HM	HR	HS	HS2	HS (LH)	HT	HE	HF	HG	HM	HR	HS	HS2	HS (LH)	HT	A	B	C	D	E	F	G	H	I
	Frnt	Rr	Ttl	Frnt	Rr																											
¹⁾ 9600 LT245/75R16	3128	2307	5435	4300	6084	-	17.0	84.1	19.7	27.7	20.0	20.9	-	29.3	-	15.2	81.3	17.5	24.3	17.8	18.8	-	25.3	19	31	24	27	15	20	-	-	-

G 33706		155.0" Wheelbase				Frame Heights at Minimum Curb Weight								Frame Heights and Angular Dimensions are shown at Maximum GAWR Front/Rear																		
GVW/Tire	Minimum Curb Weight			GAWR		HE	HF	HG	HM	HR	HS	HS2	HS (LH)	HT	HE	HF	HG	HM	HR	HS	HS2	HS (LH)	HT	A	B	C	D	E	F	G	H	I
	Frnt	Rr	Ttl	Frnt	Rr																											
¹⁾ 9600 LT245/75R16	3339	2619	5958	4300	6084	-	17.0	83.5	19.6	27.2	19.8	20.6	-	28.7	-	15.5	81.4	17.9	24.3	18.0	18.9	-	25.3	19	32	25	27	15	20	-	-	-

NOTE: Front coil springs, torsion bars and adjusters are computer selected based on model options and calculated sprung curb weight. Actual heights may vary due to production tolerances.

1) Base GVWR — contains minimum equipment required

2) Optional GVWR — contains minimum equipment required

(—) = not applicable for this model

FRAME HEIGHT AND RAMP ANGLE DATA

G/H Van - Cutaway

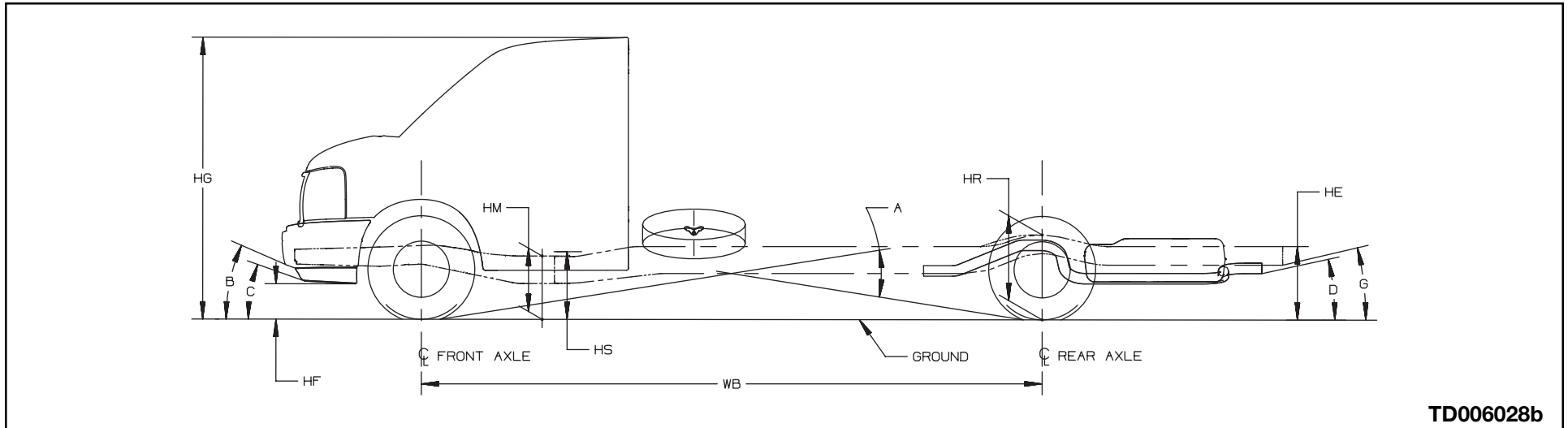

TD006028b

Heights (To Ground)

- HE Top of Frame at End
- HF Bottom of Front Air Deflector or Bumper
- HG Roof Height
- HM Normal Top of Frame
- HR Top of Frame at Centerline of Rear Axle
- HS Step H-Point-Front
- HS2 Step H-Point-Second
- HT Rear Cargo Load Height

Angle

- A Ramp Breakover

Approach Angle(s) (Bottom of)

- B Front Air Deflector
- C Air Dam

Departure Angle(s) (Bottom of)

- D Tail pipe
- E Platform Hitch
- F Rear Bumper
- G Frame at End

NOTE: All weights are in pounds, dimensions are in inches and angles are in degrees.

FRAME HEIGHT AND RAMP ANGLE DATA

G 33503		139.0" Wheelbase				Frame Heights at Minimum Curb Weight								Frame Heights and Angular Dimensions are shown at Maximum GAWR Front/Rear																		
GVW/Tire	Minimum Curb Weight			GAWR		HE	HF	HG	HM	HP	HR	HS	HS2	HT	HE	HF	HG	HM	HP	HR	HS	HS2	HT	A	B	C	D	E	F	G	H	I
	Frt	Rr	Ttl	Frt	Rr																											
¹⁾ 9600 LT245/75R16	2838	1750	4588	4100	6084	28.6	16.9	83.7	24.9	-	29.8	20.9	-	-	25.0	14.7	81.8	22.5	-	27.0	18.6	-	-	24	30	23	21	-	-	18	-	-
²⁾ 10,000 LT225/75R16	2906	1905	4811	4100	7500	28.1	16.4	83.2	24.4	-	29.4	20.4	-	-	22.8	14.3	82.3	22.1	-	26.1	18.2	-	-	23	29	22	19	-	-	16	-	-
²⁾ 11,000 LT225/75R16	2906	1905	4811	4100	8250	28.2	16.4	83.2	24.4	-	29.4	20.4	-	-	23.0	14.4	82.0	22.0	-	26.0	18.2	-	-	23	29	22	19	-	-	16	-	-
²⁾ 11,500 LT225/75R16	2910	1994	4904	4300	8250	28.0	16.6	83.3	24.4	-	29.4	20.5	-	-	23.4	14.4	81.6	21.8	-	26.1	18.1	-	-	22	29	22	19	-	-	16	-	-
²⁾ 12,000 LT225/75R16	2906	1905	4811	4300	8600	28.1	16.6	83.3	24.5	-	29.4	20.5	-	-	23.4	14.4	81.4	21.8	-	26.0	18.0	-	-	22	29	22	19	-	-	16	-	-
²⁾ 12,300 LT225/75R16	2960	1995	4955	4300	8600	28.3	16.4	83.3	24.5	-	29.5	20.5	-	-	23.7	14.4	81.1	21.7	-	26.0	18.0	-	-	22	29	22	19	-	-	16	-	-

NOTE: Front coil springs, torsion bars and adjusters are computer selected based on model options and calculated sprung curb weight. Actual heights may vary due to production tolerances.

1) Base GVWR — contains minimum equipment required

2) Optional GVWR — contains minimum equipment required

(—) = not applicable for this model

FRAME HEIGHT AND RAMP ANGLE DATA

G 33803		159.0" Wheelbase				Frame Heights at Minimum Curb Weight							Frame Heights and Angular Dimensions are shown at Maximum GAWR Front/Rear																			
GVW/Tire	Minimum Curb Weight			GAWR		HE	HF	HG	HM	HP	HR	HS	HS2	HT	HE	HF	HG	HM	HP	HR	HS	HS2	HT	A	B	C	D	E	F	G	H	I
	Frnt	Rr	Ttl	Frnt	Rr																											
¹⁾ 10,000 LT225/75R16	3059	1746	4805	4100	7500	28.2	16.1	82.8	23.9	-	29.5	20.0	-	-	22.9	14.4	82.2	21.8	-	26.1	18.0	-	-	22	29	22	15	-	-	16	-	-
²⁾ 11,000 LT225/75R16	3059	1746	4805	4100	8250	28.2	16.1	82.8	24.0	-	29.5	20.0	-	-	23.0	14.4	81.9	21.6	-	26.0	17.9	-	-	22	29	22	15	-	-	16	-	-
²⁾ 11,500 LT225/75R16	3059	1746	4805	4300	8250	28.1	16.3	82.9	24.0	-	29.5	20.2	-	-	23.3	14.4	81.5	21.5	-	26.0	17.9	-	-	21	29	22	15	-	-	16	-	-
²⁾ 12,000 LT225/75R16	3059	1746	4805	4300	8600	28.1	16.3	82.9	24.0	-	29.5	20.2	-	-	23.4	14.4	81.3	21.5	-	26.0	17.8	-	-	21	29	22	15	-	-	16	-	-
²⁾ 12,300 LT225/75R16	3109	1834	4943	4300	8600	28.3	16.2	82.9	24.0	-	29.6	20.1	-	-	23.6	14.4	81.0	21.4	-	26.0	17.8	-	-	21	29	22	16	-	-	16	-	-

G 33903		177.0" Wheelbase				Frame Heights at Minimum Curb Weight							Frame Heights and Angular Dimensions are shown at Maximum GAWR Front/Rear																			
GVW/Tire	Minimum Curb Weight			GAWR		HE	HF	HG	HM	HP	HR	HS	HS2	HT	HE	HF	HG	HM	HP	HR	HS	HS2	HT	A	B	C	D	E	F	G	H	I
	Frnt	Rr	Ttl	Frnt	Rr																											
¹⁾ 12,000 LT225/75R16	2651	2205	4856	4600	8600	27.3	17.4	83.3	24.2	-	29.3	20.6	-	-	23.2	14.3	81.4	21.3	-	26.0	17.7	-	-	19	29	22	15	-	-	16	-	-
¹⁾ 12,300 LT225/75R16	2704	2287	4991	4600	8600	27.4	17.3	83.2	24.2	-	29.4	20.6	-	-	23.4	14.3	81.1	21.2	-	26.0	17.6	-	-	19	29	22	15	-	-	16	-	-

NOTE: Front coil springs, torsion bars and adjusters are computer selected based on model options and calculated sprung curb weight. Actual heights may vary due to production tolerances.

1) Base GVWR — contains minimum equipment required

2) Optional GVWR — contains minimum equipment required

(—) = not applicable for this model