

GENERAL INFORMATION

PROCEDURE FOR HANDLING CHASSIS/DEALER CLAIMS	1
General	1
Shipments Received from Truckaway or Driveaway Company	1
If Received from Railroad	1
Filing a Claim	2
Disposition of Damaged Parts	2
GOVERNMENT REGULATIONS	2
Introduction	2
Responsibility for Complete Vehicle Performance	2
Noise Emission Standards for Transportation Equipment – Medium and Heavy Trucks	3
40 CFR Part 205	3
Method of Certification by GM	4
Completed Vehicle	4
Certification Labels	4
Method of Certification	4
Incomplete Vehicles	4
Models	5
Vehicle Classification and GM Application	6
Federal Regulations – Tires	7
GM FLEET & COMMERCIAL OPERATIONS	8
BASE MODEL WEIGHT INFORMATION	8
PAYLOAD DETERMINATION	9
Payload Definition	9
Incomplete Vehicle Payload Determination	11
Payload Definition	11
Percentage Body and Payload Weight at Front Axle	13

GENERAL INFORMATION

PAYLOAD DETERMINATION – *Continued*

Reserve Capacity Determination	15
Cargo Weight Definition	15
VEHICLE CENTER OF GRAVITY	17
Determining Vehicle Center of Gravity – Hoist Method	17
Introduction	17
Recommended Procedure	17
Steps	17
Determining Vehicle Center of Gravity – Hoist Method Data Sheet	19
Calculating the Vehicle Center of Gravity Location	20
Determining Vehicle Center of Gravity – Hoist Method Illustrations	21
WEIGHTS AND MEASURES	22
Standard Weights and Measures	22
Metric Weights and Measures	23
Equivalent Weights and Measures	23
Decimal Equivalents of Parts of an Inch	24
Approximate Weight of Materials	25
METRIC/U.S. CUSTOMARY CONVERSION TABLE	34
2004 LIGHT DUTY 10/1500 – 30/3500 SERIES MODEL IDENTIFICATION SYSTEM	35

GENERAL INFORMATION

PROCEDURE FOR HANDLING CHASSIS/DEALER CLAIMS

General

All chassis tendered for delivery by the Transportation Company are to be accepted by the Body Company. If a chassis has been damaged or is short certain parts when received by the Body Company, they will repair or replace missing parts, if possible, with their own or other local facilities and promptly forward the claim to the dealer.

If the Body Company or other local facilities are not adequate for replacing missing or damaged parts, the Body Company will promptly notify the Dealer and hold damaged chassis awaiting his instructions. The Dealer must be notified promptly upon receipt of a chassis on which a claim is in order giving the "model", "engine number," and "serial number" and what the damage or shortage consisted of. This is important since Chevrolet/GMC Truck cannot accept claims from the Dealer unless filed within thirty days from date of delivery, or unless within the thirty-day period, the Dealer has advised Chevrolet/GMC Truck that a claim will be filed. Delivery to the Body Company constitutes delivery to the Dealer, since the Body Company is the Dealer's agent.

Completed vehicles that are to be driven to the Dealer or the Dealer's customer must first be serviced by the Body Company at the Body Company's location in accordance with Chevrolet/GMC Truck new vehicle conditioning procedures. Expenses incurred for this condition are the responsibility of the selling Dealer.

Shipments Received from Truckaway or Driveaway Company

The Body Company will inspect condition of chassis and call driver's attention to damage or missing parts and make a detailed notation of both copies of the Transportation Company's delivery receipt of the nature and extent of the existing damage and/or shortage and have driver sign such notation on the Dealer's copy. If chassis are received after business hours and cannot, therefore, be adequately inspected, the delivery receipt (both copies) is to carry notation "Received subject to inspection" and show the time and date. On such chassis, a detailed inspection must be made within 24 hours or on the first working day after receipt of chassis and immediately furnish to the Dealer. Any exceptions are to be noted on both copies of the delivery receipt by the Body Company.

If Received from Railroad

Freight car should be opened and contents inspected in presence of railroad representative before starting to unload, and any existing damage or shortage recorded by the railroad representative on his standard inspection report. Body Company must secure from railroad agent, a copy of his inspection report detailing nature and extent of the damage and/or shortage.

If the railroad representative does not comply with consignee's request to make an inspection, then the Body Company will immediately confirm his request (in writing) to the railroad agent, outlining the nature and extent of damage and/or shortage disclosed by consignee's inspection, prior to starting any unloading operations, sending a copy of his letter to the Dealer.

(Procedures for Dealer Claims continued on next page)

GENERAL INFORMATION

(Procedures for Dealer Claims continued from previous page)

Filing a Claim

Upon completion of repairs or replacements of missing parts, the Body Company will promptly bill the Dealer for the cost involved, supporting such debit with a detailed statement showing how the amount is arrived at end, either the original delivery receipt with notation if received from a truckaway company or the carrier's inspection report if received from a railroad.

Disposition of Damaged Parts

Damaged parts removed from chassis by the Body Company must be held for disposition orders from the Dealer.

Dealer claims will not be allowed unless above instructions are fully complied with.

GOVERNMENT REGULATIONS

Introduction

The Federal Government has established Motor Vehicle Safety Standards for various categories of motor vehicles and motor vehicle equipment under the provisions of the National Traffic and Motor Vehicle Safety Act of 1966. The Act imposes important legal responsibilities on manufacturers, dealers, body builders and others engaged in the manufacturing and marketing of motor vehicles and motor vehicle equipment.

Questions dealing with the specific application of the Act or the standards to your business should be discussed with your legal counsel. This is particularly so because the standards and other requirements or interpretations are subject to change by the government agency in charge, the National Highway Traffic Safety Administration.

New standards and amendments issued by the National Highway Traffic Safety Administration will appear in the Federal Register from time to time. You may obtain the Federal Register, through the Superintendent of Documents, U.S. Government Printing Office, Washington, D.C. 20402, or at <http://www.NHTSA.dot.gov/cars/rules/>.

Responsibility for Complete Vehicle Performance

General Motors performs extensive testing on all trucks described in this book. Major changes to a complete vehicle or the installation of a body on an incomplete truck chassis will, however, affect vehicle performance.

(Government Regulations continued on next page)

(Government Regulations continued from previous page)

It is the responsibility of the body and equipment manufacturers to validate final completed vehicle performance. Total vehicle system performance tests may be required. The test schedule must reflect the type of vehicle system loading to which the completed vehicle will be subjected, and must also include consideration of all aspects of performance, e.g., durability, ride, handling, etc.

Noise Emission Standards for Transportation Equipment – Medium and Heavy Trucks

40 CFR PART 205

The U.S. Environmental Protection Agency (EPA) has established noise emission standards applicable to vehicles (in general vehicles in excess of 10,000 pounds GVWR capable of transportation of property on a street or highway) manufactured after January 1, 1978, under the provisions of the Noise Control Act of 1972. The standards provide that vehicles manufactured after January 1, 1978, when tested pursuant to EPA's prescribed test procedure, must conform to an 83 dBA level and vehicles manufactured after January 1, 1988 must conform to an 80 dBA level.

The Act and the standards impose legal obligations on vehicle manufacturers and subsequent manufacturers. Questions dealing with what is covered under the definition of a "vehicle" in the standards and the specific application of the Act or the standards to your business should be discussed with your legal counsel. This is particularly so in light of EPA's broad definition of a "vehicle."

The standards or interpretations of such standards are subject to change by EPA. New standards or amendments issued by the Environmental Protection Agency appear in the Federal Register from time to time. You may obtain the Federal Register through the Superintendent of Documents, U.S. Government Building Office, Washington, D.C. 20402.

NOTE: Model and option weight information is available in the GM Medium Duty Data Book. Contact your local GM dealer for assistance.

Method of Certification by GM

Completed Vehicle

A completed vehicle will have the certification label installed before shipment from the factory.

Certification Labels

Models:

C/K 1500/2500/3500 Pickups,
Chevy Silverado and GMC Sierra/Sierra Denali,
C/K 1500/2500 Utilities, Chevy Tahoe/Suburban/Avalanche
and GMC Yukon/Yukon XL/Yukon Denali/Yukon Denali XL
G 1500/2500/3500 Vans,
Chevy Express Cargo/Express Passenger/Express Cut-a-way
and GMC Savana Cargo/Savana Passenger/Savana Cut-a-way

Models:

M/L 1500 Vans, Chevy Astro Cargo/Astro Passenger
and GMC Safari Cargo/Safari Passenger
S/T 10/1500 Pickups, Chevy S10/Colorado and GMC Sonoma/Canyon
S/T 10/1500 Utilities, Chevy Blazer/TrailBlazer/TrailBlazer EXT
and GMC Envoy/Envoy XL/Envoy XUV

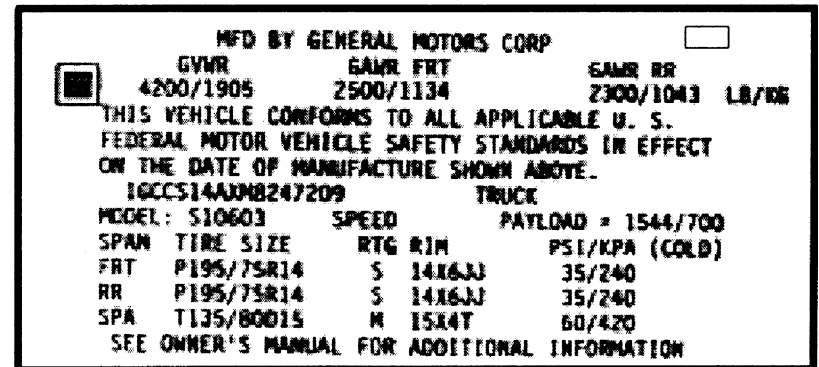
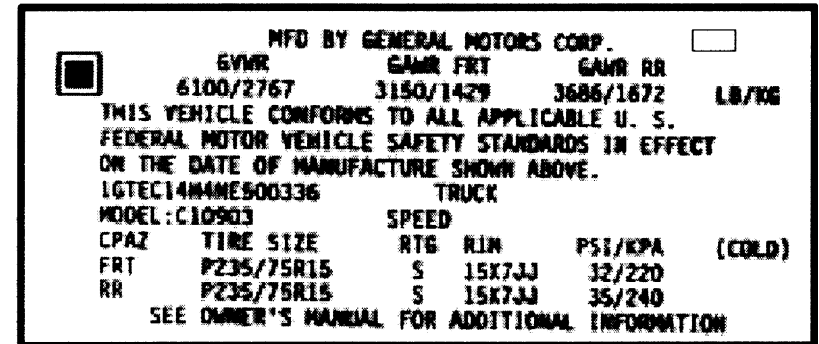

Method of Certification

Incomplete Vehicles

Will have a label affixed to the Document for Incomplete Vehicles. This is placed in a clear container and shipped with the incomplete vehicle from the factory.

(Method of Certification continued on next page)

GENERAL INFORMATION

(Method of Certification continued from previous page)

**DOCUMENT
FOR
INCOMPLETE VEHICLE**

[PLACE LABEL HERE]

This document is furnished as required by government regulation to aid intermediate and final stage manufacturers in determining conformity to applicable Federal Motor Vehicle Safety Standards. Also included are instructions which must be followed in order to assure that Environmental Protection Agency (EPA) and California emission certification requirements and NHTSA Fuel Economy Regulations are met. As a result of certifying Heavy Duty Vehicles with GVW's up to 10,000 pounds by Federal Light Duty Emission Standards, Part II of this document – U.S. EPA and California Exhaust & Evaporative Emission Requirements and NHTSA Fuel Economy Regulations—has been significantly revised and should be reviewed. This document is not a substitute for knowledge and understanding of the requirements of these standards and regulations. Intermediate and final stage manufacturers should be familiar with all Federal Motor Vehicle Safety Standards and Emission Regulations to be aware of their specific responsibilities as manufacturers.

Any manufacturer making material alterations to this incomplete vehicle during the process of manufacturing the complete vehicle should be constantly vigilant to recognize all the effects, either direct or indirect, on other components, assemblies or systems caused by each such alteration. No alteration should be made to the incomplete vehicle which either directly or indirectly results in any component, assembly or system being in nonconformance with any applicable Federal Motor Vehicle Safety Standard or Emission Regulation.

CANADA MOTOR VEHICLE SAFETY STANDARDS

The following statement, which is required by Section 6.4) (a) of the Canada Motor Vehicle Safety Regulations is applicable only to incomplete vehicles manufactured in or imported to Canada:

THIS INCOMPLETE VEHICLE CONFORMS TO THE APPLICABLE CANADA MOTOR VEHICLE SAFETY STANDARDS IN EFFECT ON THE DATE OF ITS MANUFACTURE SHOWN ABOVE. THE STANDARDS TO WHICH THIS INCOMPLETE VEHICLE CONFORMS IN FULL ARE DESIGNATED IN THE LIST OF FEDERAL MOTOR VEHICLE SAFETY STANDARDS ON PAGE 3 BY AN ASTERISK (*) IN THE COLUMN FOR THE BASIC TYPE OF INCOMPLETE VEHICLE.

Printed in U.S.A.



Models

All incomplete vehicles; C/K Chassis-Cabs, 2500/2500HD/3500 Series with option ZW9 and /3600 Series;
M/L Cargo Van with option YF7 Recreational Upfitters (Conversion Vans);
G/H Cargo Vans, with option YF7 Recreation Upfitters (Conversion Vans) and with option Y3G (Personnal)/Y3H (Paratransit) Mobility Upfitters and with option B3D (School Bus)
G Cutaway Vans.

Vehicle Classification and GM Application

Model	Application (Chevy / GMC)	Vehicle Classification		
		MPV	Truck ¹⁾	Bus ¹⁾
M/L Series	Astro/Safari-Cargo/Passenger Van	X ³⁾	X	
S/T Series	S/T Series S10/Sonoma and Colorado/Canyon Regular/Extended/Crew Cab Pickups	X ²⁾	X	
S/T Series	S/T Series Blazer (2 & 4 Door) and Trailblazer/Trailblazer EXT/Envoy/Envoy XL/Envoy XUV	X ³⁾	X	
C/K 1500 Series	Tahoe/Yukon (4 Door)	X ³⁾	X	
C/K 1500-3500 Series	C/K/Silverado/Sierra Chassis-Cabs/Regular/Extended/Crew Cab Pickups	X ²⁾	X	
C/K 1500-2500 Series	Suburban/Yukon XL	X ³⁾	X	
G 1500-3500	Express Cargo Van/Savanna Cargo Van	X ²⁾	X	X
G 1500-3500	Express/Savanna Passenger Van	X ³⁾		
G 3500 Series	Commercial/RV Cutaway/Savanna Special	X ²⁾	X	X

1) It is assumed that Cab and Chassis only will be completed as a truck. Chassis only with RPO B3D or B3M will be completed into a school bus.

2) MPV Classification may apply only when unit is completed as a Recreation Vehicle (Camper).

3) MPV is a vehicle with 2 or 3 rows of seats.

Federal Regulations – Tires

The National Highway Traffic Safety Administration has issued regulations dealing with tire identification and record keeping which became effective May 22, 1971. Under these regulations important legal responsibilities are imposed upon tire manufacturers, brand name owners, retreaders, distributors and dealers, and motor vehicle manufacturers and dealers, to maintain and/or report certain information concerning tires. This information will be used to facilitate interest of safety. If you have any questions concerning the application of these regulations to your business, we suggest you consult with your attorney.

In order for GM to meet its responsibility under these tire regulations we have a record of the tires on each vehicle we shipped to you. If you do not change a tire on a GM vehicle, it is important that you make sure that it is reshipped with the same tires that were on it when the vehicle was received by you. This will mean that any tires which you remove from a vehicle during the course of your work should be put back on the same vehicle.

If you do change a tire on a GM vehicle, it is necessary that you furnish us with such information on vehicles which are returned to us after you have completed your work. It is important that you report to us the full tire identification number (TIN) for each tire you install and the full vehicle identification number (VIN) of the vehicle on which the tire is installed.

If you change a tire on a GM vehicle which is not returned to us, you may be responsible for maintaining records of the vehicle identification number (VIN) and the vehicle owner to allow notification, through your records, if tire problems are found.

In case you should receive a defect notification from a tire manufacturer concerning tires which you installed on a vehicle returned to us, you may forward it to us so that we can send it to the vehicle owner whose name will appear on our records.

GENERAL INFORMATION

GM FLEET & COMMERCIAL OPERATIONS

Region	Mailing Address		
		Telephone	Fax
Northeast	2500 Westchester Ave. Purchase, NY 10577 - 0890	(914) 251-5050	(914) 251-5229
North Central	387 Shuman Blvd, Naperville, IL 60563 - 1217	(630) 961-6425	(630) 961-6379
Southeast	5730 Glenridge Drive Atlanta, GA 30328	1 800 248-0178	(404) 257-3595
South Central	130 E. Carpenter Fwy, Ste. #200 Irving, TX 75062	(972) 541-5415	(972) 541-5424
Western	515 Marin St. Thousand Oaks, CA 91360	1 800 510-3973	(805) 373-8432

BASE MODEL WEIGHT INFORMATION

DATA NOT AVAILABLE AT TIME OF PUBLICATION

PAYLOAD DETERMINATION

Payload Definition

Maximum allowable weight of cargo to be carried in a vehicle, including occupants. Computed by subtracting curb weight from GVWR.

Light trucks are designed to offer the customer a selection of payload capacities to meet their varying needs. This section of the Data Book lists the base and max payload capacity of all truck models. It does not list payloads for vehicles with optional suspensions, axles, wheels or tires, aftermarket accessories, equipment or bodies.

The reason is that each additional piece of equipment affects payload. With the number and variety of options, bodies and accessories available, there is an almost infinite number of possible payloads.

When a customer wants to know the payload of a truck in stock or a truck being ordered, and that truck is a model with optional equipment, you must perform a simple calculation to provide the information.

Here's how to do this

What to Do	Where to Find the Information
1. Determine truck's Gross Vehicle Weight Rating (GVWR)	GVWR Selector Section
2. Determine the truck's Curb Weight (Curb weight = full fuel, no occupants)	Model and Option Weights
3. Determine the truck's option content and the weight of each piece of optional equipment	Model and Option Weights
4. Subtract the Curb Weight and the Option Weight(s) from the truck's Gross Vehicle Weight Rating	

NOTE: The following example is based on 2004 base model and option weights contained in "GM Dealer World, Weight Calculator."

GENERAL INFORMATION

Example

A customer asks you for the payload of a C1500 Regular Cab Pickup (C15903/C7H) with an optional 5.3L V8 engine (RPO LM7), Automatic 4-speed transmission (RPO M30) and a chromed rear step bumper. You perform the following calculation:

1. Gross Vehicle Weight Rating (GVWR) (C5M)		6400.0 lbs.
2. Curb Weight (C15903)	-	4109.6 lbs.
3. 5.3L V8 gasoline engine w/automatic transmission (M30)	-	51.0 lbs.
4. Chrome rear step bumper (VB3)	-	00.0 lbs.
<hr/>		
Payload	=	2239.4 lbs

Incomplete Vehicle Payload Determination

Payload Definition

Maximum allowable weight of cargo to be carried in a vehicle, including occupants. Computed by subtracting curb weight from GVWR.

Determining the available payload for an incomplete vehicle (such as a chassis-cab) is similar to a completed vehicle, but the weight of the added body and any accessories must also be subtracted from the GVWR.

What to Do	Where to Find the Information
1. Determine truck's Gross Vehicle Weight Rating (GVWR)	GVWR Selector Section
2. Determine the truck's Curb Weight (Curb weight = full fuel, no occupants)	Model and Option Weights
3. Determine the truck's option content and the weight of each piece of optional equipment	Model and Option Weights
4. Subtract the Curb Weight and the Option Weight(s) from the truck's Gross Vehicle Weight Rating to determine the payload capacity	
5. Subtract the determined weight of body and accessories	Body Manufacturer/Distributor

NOTE: The following example is based on 2004 base model and option weights contained in "GM Dealer World, Weight Calculator."

GENERAL INFORMATION

Example

A customer asks you for the payload for a C/K Chassis-Cab (C36003 w/C7W) with the optional Vortec 8100 V8 gasoline engine (L18), with a 5-speed Allison Automatic Transmission (M74), with an aftermarket stake body. You calculate the following:

1. Gross Vehicle Weight Rating (GVWR), option C7W		11,400.0 lbs.
2. Curb Weight (C36003)	-	5230.6 lbs.
3. Vortec 8100 V8 Gasoline Engine w/5-speed Allison automatic trans	-	329.1 lbs.
4. Stake Body	-	850.0 lbs.
<hr/>		
Payload	=	4990.3 lbs

Percentage Body and Payload Weight at Front Axle

To determine percentage of load at rear axle, subtract percentage of load at front axle from 100.0%. Tables are calculated using the following formula:

$$\frac{100 \times (X)}{\text{Wheelbase}} = \% \text{ Body and Payload at Front Axle}$$

NOTE: Body Length is in inches for equation:

- CA = Cab to rear Axle dimension
- BC = Body Clearance between body and cab
- B = Body length
- WB = Wheel Base
- X = Center of gravity of payload to rear axle dimension

$$\frac{100 \times CA - [(BC) + B/2]}{\text{Wheelbase}} = \% \text{ Body Payload at Front Axle}$$

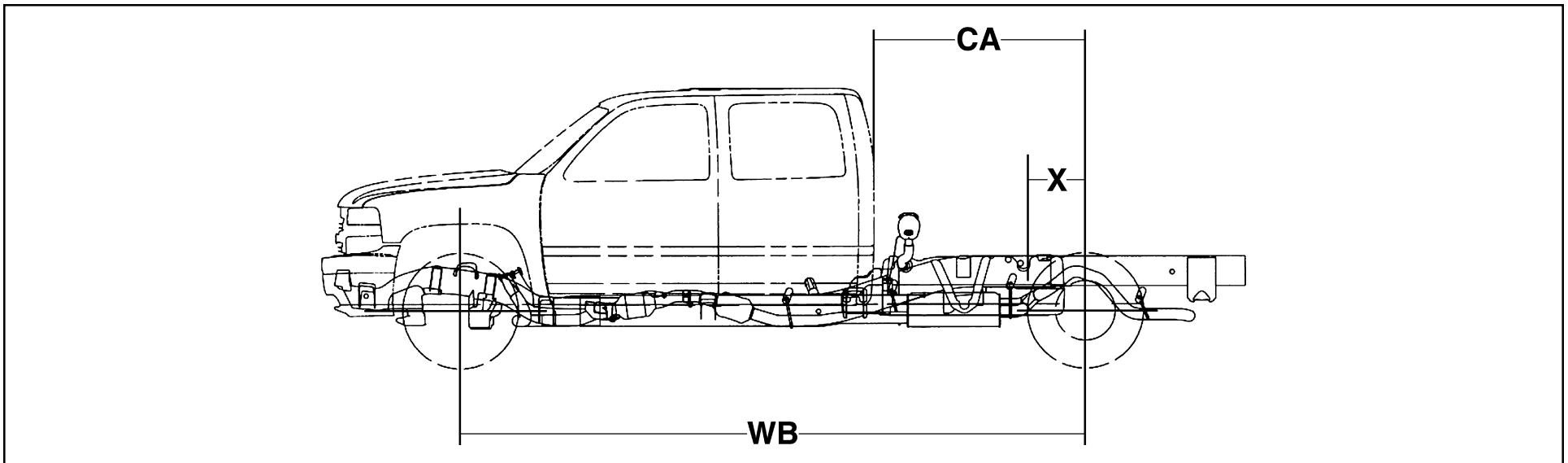

(Percentage Body and Payload Weight at Front Axle continued on next page)

(Percentage Body and Payload Weight at Front Axle continued from previous page)

Body lengths, and percentage figures are found in the Body-Payload Weight Distribution Charts located in the model weight section for pickup and C/K chassis cabs. These charts represent all lengths that are possible to use. The shortest length in each case represents the smallest body that will reach the approximate end of the chassis frame at the maximum cut off. The longest length represents the largest body which can be used without placing the center of gravity behind the rear axle.

Body lengths shown in the Body-Payload Weight Distribution Charts represent the entire outside length of the body (not necessarily nominal length) including sills or extensions of any kind. The center of gravity used is the exact center of the body length. For specific cases the exact center of gravity of body and payload should be determined. Body and payload center of gravity should always be ahead of the center line of the rear axle or bogie suspension. If the center of the load is behind the rear axle it will result in reduced steering control and may even lift the front wheels off the ground.

Weight distribution should be computed for all body applications. Some clearance must be maintained between the cab and body.

Results of a weight distribution calculation should show:

1. Weight at front as close as possible, but not exceeding, front suspension capacity
2. Weight at rear as close as possible, but not exceeding, rear axle capacity
3. Front weight at ground of the loaded vehicle must exceed the front weight at ground of the unloaded vehicle

If these conditions do not exist, recalculate the weight distribution using either different body or chassis size or using a different location of the body.

Extreme caution should be exercised in selecting the shortest or longest allowable body lengths. The shortest lengths will usually shift a major portion of the body and payload weight to the front axle of the vehicle. This will limit driver control of steering and reduce traction at the rear wheels. The longest bodies will usually restrict the weight distributed to the front axle. This will reduce the effect the steering mechanism and front wheels have on controlling the vehicle's direction of movement. In cases of special body and/or load distribution or where axle capacities are extremely over or under loaded, consult the factory for recommendations.

Reserve Capacity Determination

Cargo Weight Definition

Weight of the load carrying capability. Computed by subtracting passenger and curb weight from GVWR.

It is important to sell your customer the right truck for the right job. One way to make sure your customers are buying the right truck is to determine what they will be carrying, how much it weighs and then recommend a truck capable of carrying the load.

GMC Truck offers a variety of models in each truck line. Each model has specific capacities. It is essential to determine the weight of the payload your customers will be carrying to determine if the truck you're recommending will carry the load.

The following process will help you accomplish that task

What to Do	Where to Find the Information
1. Select the approximate weight of the material your prospect wishes to carry.	Weights and Measures section to find approximate weights of a variety of cargos.
2. Determine which truck would best suit the customer. Use the pages at the beginning of this section to find a model with a payload in the range of the weight of the cargo the customer wishes to carry.	Payload/GVWR Calculations
3. Select the percentage weight distribution of the model you have chosen. If the payload for your vehicle is not at a water level load you must calculate the percent of weight the payload will put on the front axle using the formula provided.	Consult the Percentage Weight Distribution Table in the Model and Option Weights section for pickup and chassis cab water level loading.
4. Determine the percentage weight distribution of the cargo your prospect wishes to carry. Use the percentage weight distribution figures to determine the front percentage and rear percentage.	
5. Determine the front and rear curb weight of the vehicle you are considering (no passenger weight).	Consult the Model and Option Weights section for the weights of the vehicle you are considering.
6. Determine the front and rear weight of any optional equipment.	Consult the Model and Option Weights section for the weights of the vehicle you are considering.

GENERAL INFORMATION

What to Do	Where to Find the Information
<p>7. Add the total front and rear cargo weights, front and rear curb weight, and the option weights together. The result will be the amount of weight to be supported by the front axle of the vehicle you've chosen, and the amount of weight to be supported by the rear axle. This is called the Front Gross Axle Weight and the Rear Gross Axle Weight.</p>	
<p>8. Determine the front and rear Gross Axle Weight Rating of the vehicle you are considering. If the Gross Axle Weight Rating of the vehicle you are considering is higher than the Gross Axle Weight you've calculated, the vehicle you are considering should be right for the job. If not, you'll need to find a model with Gross Axle Weight Rating high enough to carry the load you've calculated.</p>	<p>Consult the GVWR Selector of the vehicle ordering sections.</p>
<p>9. One more step is necessary before recommending the model. Add the front and rear Gross Axle Weight together. This number is the Gross Vehicle Weight.</p>	
<p>10. Insert the Gross Vehicle Weight Rating of the model you have selected and compare it to the Gross Vehicle Weight. If the (GVW) is lower, then the model should be right for the job. If not, consult the Base Payload pages at the beginning of this section to find a vehicle with a higher GVWR.</p>	<p>Consult the Axle/Suspensions pages to find GAWRs in the range required. The models possessing these GAWRs are also listed. GVWRs are also listed.</p>
<p>11. Add the front Gross Axle Weight and the rear Gross Axle Weight together to determine the Gross Vehicle Weight. Subtract the Gross Vehicle Weight from the Gross Vehicle Weight Rating.</p>	
<p>12. Subtract the passenger weight to determine the total reserve capacity.</p>	<p>Calculated Value: (Number of passengers and driver x 150 lbs. per person)</p>

VEHICLE CENTER OF GRAVITY

Determining Vehicle Center of Gravity – Hoist Method

Introduction

This information is being used to assist specialty vehicle manufacturers (SVMs) in determining the vehicle center of gravity of upfitted vehicles. General Motors is providing this information to upfitters in addition to the information already available in the Incomplete Vehicle document and Body Builders Book so that SVMs can determine compliance with FMVSS 105 for their completed vehicles in a more simplified and consistent manner. This has been prepared for use by knowledgeable test engineers. It is not a “how to” document for use by people without formal technical training.

 All distances are to be measured in inches to two decimal places. All weights are to be measured in whole pounds. All angles are to be measured in decimal degrees to one decimal place. Be sure the doors and hood are closed during all weighing. Use appropriate safety practices throughout the procedure.

Recommended Procedure

Steps

1. Prepare the vehicle for center of gravity testing. Start with vehicle curb weight (the weight of the completed vehicle with no passengers or payload and all fluids at maximum specified capacity) and add 400 pounds to the vehicle. Distribute the 400 pounds in the driver-passenger area of the vehicle so that the side-to-side difference is less than 50.
2. Place the vehicle on a level surface and check all tire pressures to be sure they are at the Isuzu/General Motors specified tire pressure (see the label on the vehicle door or pillar).

Measure the radius “**A**” of the left front wheel (the distance from the center point of the wheel to the ground) and record on page 23 (see Figure 1 on page 25).

Measure the radius “**B**” of the left front wheel (the distance from the center point of the wheel to the ground) and record on page 23 (see Figure 1 on page 25).

3. Measure the distance “**C**” between the rear wheel rims at their widest point (not the tires) and record on page 23 (see Figure 2 on page 25).
4. Measure the width “**D**” of one rear wheel rim at its widest point and record on page 23 (see Figure 2 on page 25).
5. Place the vehicle on four independent scales (or weight pads), with one wheel on each scale. These scales should have a minimum capacity of 2000 pounds each with a 1.0% maximum accuracy error rate.

(Vehicle Center of Gravity continued on next page)

(Vehicle Center of Gravity continued from previous page)

6. Weigh the vehicle on level ground. Record the weight at each of the wheels on page 23 (**E** = left front, **F** = right front, **G** = left rear, **H** = right rear).
7. Lock the steering wheel with the front wheels pointing straight ahead.
8. Place reference marks on all four corners of the vehicle (for example: front fenders and rear quarter panels: see Figure 1 on page 25).
Measure the height of each reference mark from the ground and record on page 23 (**J** = left front, **K** = right front, **L** = left rear, **M** = rear right).
9. Replace the shock absorbers with turnbuckles. Adjust the turnbuckles so that the heights of the reference marks on all four corners of the vehicle are at the same heights recorded in step 8.
10. Place the inclinometer (gravity protractor) on the right-hand frame rail. Observe the frame angle “ α ” as indicated by the inclinometer and record on page 23. Do not move the inclinometer.

 When the front of the vehicle is lower than the rear of the vehicle, the frame angle is *positive*.

11. Place ramps behind the front wheels and the scales behind the ramps so that when the rear of the vehicle is raised, the front wheels will roll onto the scales (see Figure 3 on page 25).

 Front wheels will roll rearward as the rear end of the vehicle is elevated. Adequate safety precautions must be taken during this procedure.

12. Set parking brake. Capture or cradle the rear axle and carefully raise the rear end of the vehicle with a hoist. Raise the rear end of the vehicle until the inclinometer reads an angle “ β ” that is *at least* 20 degrees greater than angle “ α ”. Record angle “ β ” on page 23. Be sure that the centerline of the rear axle stays parallel to the ground. Watch for unexpected interference conditions (for example: a ground effects package. See Figure 3 on page 25).

 Place jack stands under the rear axle as a safety precaution.

13. While the rear end of the vehicle is elevated, measure the inclined vehicle weight of the front wheels and record on page 23 (**P** = left front, **Q** = right front).
14. Carefully lower the rear end of the vehicle to the ground.
15. Restore the vehicle to its original condition by removing the turnbuckles and reinstalling the original shock absorbers. The user of this procedure is responsible to verify that the vehicle wheel alignment was not affected.
16. Finally, measure the wheelbase “**S**” (the distance between the centerlines of the front axle and the rear axle) and record on page 23 (see Figure 1 on page 25).

(Vehicle Center of Gravity continued on next page)

GENERAL INFORMATION

(Vehicle Center of Gravity continued from previous page)

Determining Vehicle Center of Gravity – Hoist Method Data Sheet

TEST DATE: _____ VIN: _____

WHEEL RADII (SEE FIGURE 1)

Left front wheel: **A** = _____ (inches)

Left rear wheel: **B** = _____ (inches)

VEHICLE TREADWIDTH (SEE FIGURE 2)

Distance between rear wheel rims: **C** = _____ (inches)

Width of rear wheel rim: **D** = _____ (inches)

Vehicle treadwidth: **T = C + D** = _____ (inches)

LEVEL VEHICLE WEIGHT

Left front wheel: **E** = _____ (pounds)

Right front wheel: **F** = _____ (pounds)

Left rear wheel: **G** = _____ (pounds)

Right rear wheel: **H** = _____ (pounds)

Total vehicle weight: **U = E + F + G + H**

U = _____ (pounds)

Initial front axle weight: **V = E + F** = _____ (pounds)

Initial rear axle weight: **W = G + H** = _____ (pounds)

LEVEL VEHICLE REFERENCE HEIGHTS

Left front corner: **J** = _____ (inches)

Right front corner: **K** = _____ (inches)

Left rear corner: **L** = _____ (inches)

Right rear corner: **M** = _____ (inches)

VEHICLE FRAME ANGLES (SEE FIGURE 3)

Initial frame angle: α = _____ (degrees)

Raised frame angle: β = _____ (degrees)

Inclined vehicle angle: $\theta = \beta - \alpha$ = _____ (degrees)

INCLINED VEHICLE WEIGHT

Left front wheel: **P** = _____ (pounds)

Right front wheel: **Q** = _____ (pounds)

Front axle weight: **R = P + Q** = _____ (pounds)

VEHICLE WHEELBASE (SEE FIGURE 1)

Wheelbase: **S** = _____ (inches)

(Vehicle Center of Gravity continued on next page)

(Vehicle Center of Gravity continued from previous page)

Calculating the Vehicle Center of Gravity Location

REFER TO ILLUSTRATIONS ON PAGE 25

1. Horizontal Front-To-Rear position of the vehicle center of gravity “CG_x.”
The equation used is:

$$CG_x = \frac{W \times S}{U}$$

See Figure 1

2. Horizontal Inboard-Outboard position of the vehicle center of gravity “CG_y.”
The equation used is:

$$CG_y = \frac{(F + H) \times T}{U}$$

See Figure 2

3. Vertical Up-And-Down position of the vehicle center of gravity “CG_z.”
The equation used is:

$$CG_z = \frac{W \times (B - A)}{U} + \frac{S \times (R - V)}{U \times \tan \theta}$$

See Figure 3

$\tan \theta$ = The tangent of angle θ



In order to correlate this data to the Incomplete Vehicle Document charts, the user must add the front wheel radius “A” to the value obtained for “CG_z.” As a result, the value used to chart the vertical center of gravity is:

$$CG_z + A$$

Refer to the *Incomplete Vehicle Document* to verify that the completed vehicle center of gravity is within the specified range.

The statistical accuracy of the determined vehicle center of gravity should be verified by conducting several tests and averaging the results.

GENERAL INFORMATION

(Vehicle Center of Gravity continued from previous page)

Determining Vehicle Center of Gravity – Hoist Method Illustrations

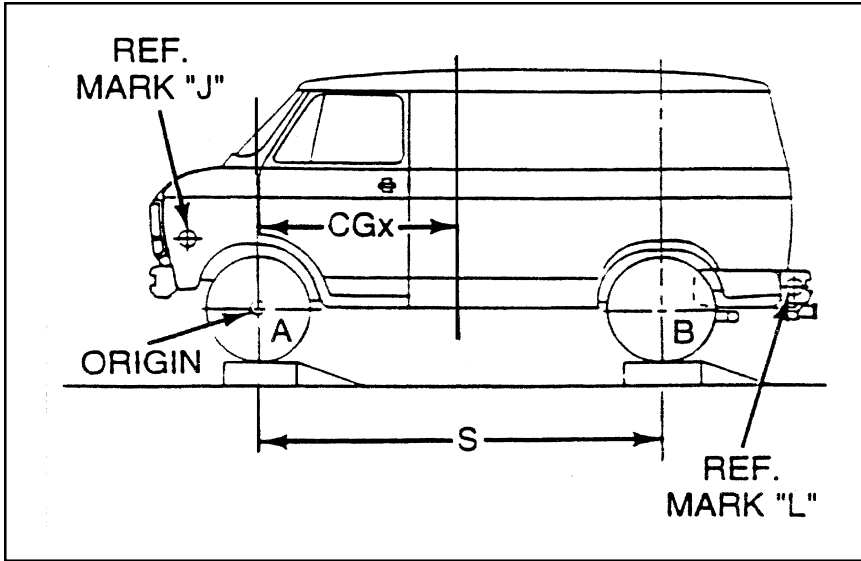

Figure 1

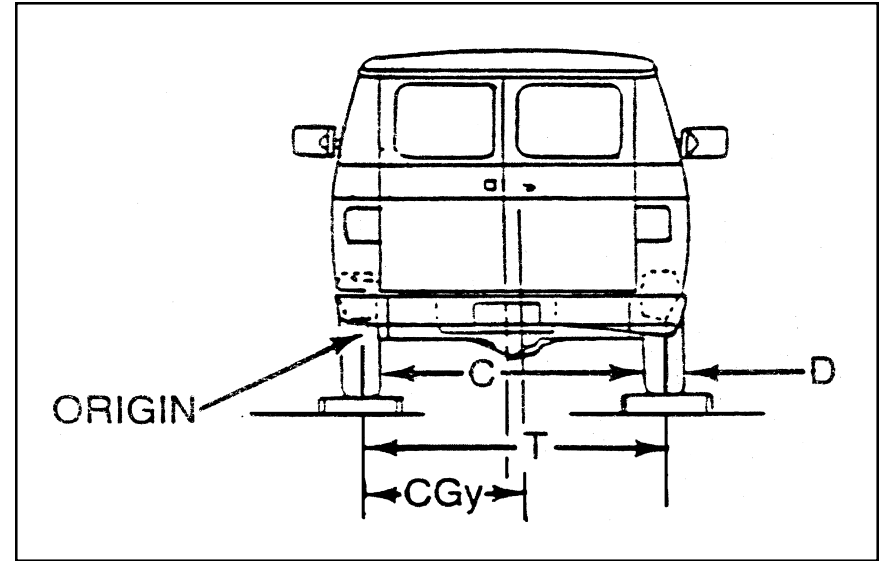

Figure 2

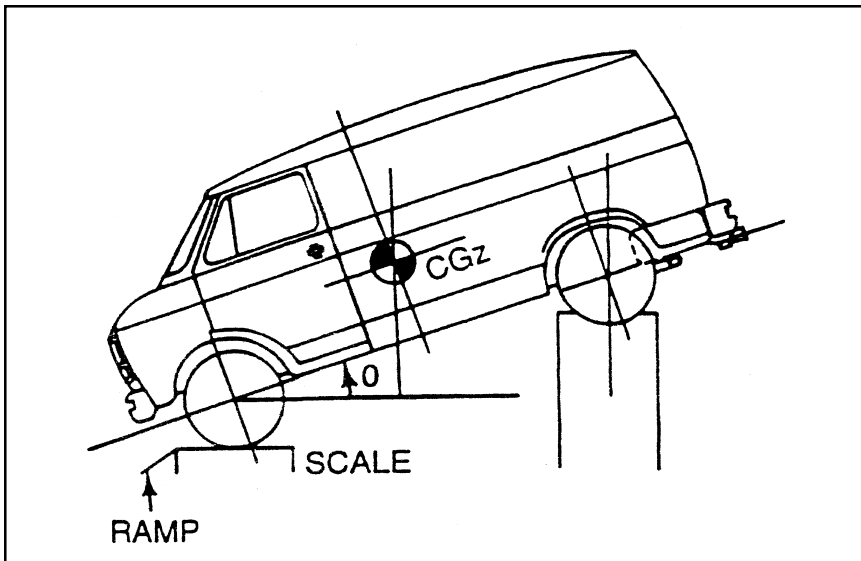

Figure 3

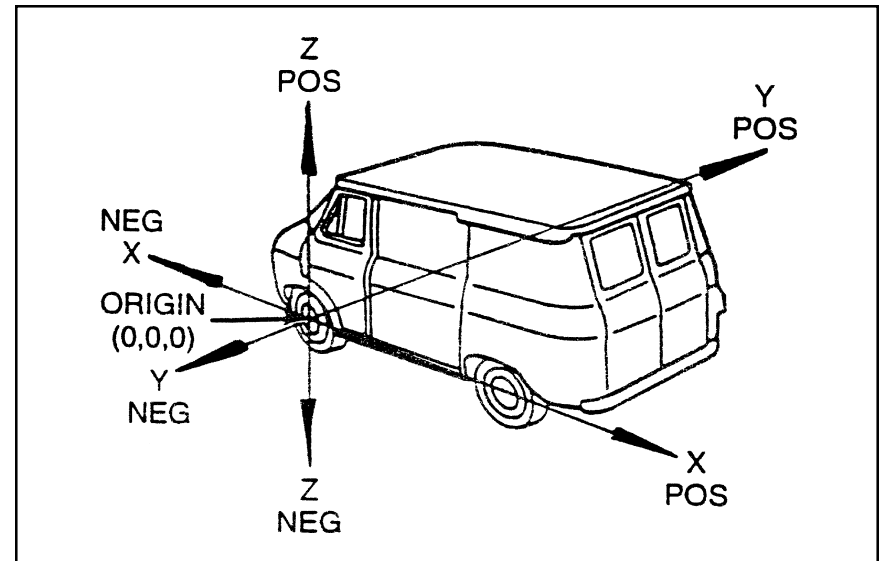

Figure 4

WEIGHTS AND MEASURES

Standard Weights and Measures		
Length		
12 inches	=	1 foot
3 feet	=	1 yard
5 1/2 yards	=	16 1/2 feet
	=	1 rod
1760 yards	=	5820 feet
	=	1 mile
Area		
144 square inches	=	1 square foot
9 square feet	=	1 square yard
30 1/2 sq. yards	=	1 square rod
160 sq. rods	=	43,560 sq. feet or 1 acre
640 acres	=	27,878,400 sq. feet or 1 sq. mile
1 circular inch	=	Area of circle 1 in diameter
1 square inch	=	1.2732 circular inches
Volume		
1728 cubic inches	=	1 cubic foot
27 cubic feet	=	1 cubic yard
1 cord wood	=	128 cubic feet. One cord is 8 feet long, 4 feet wide and 4 feet high
1 board foot	=	144 cubic inches or volume of board 1 foot square and 1 inch thick
1 cylindrical inch	=	Volume of cylinder 1 inch in diameter and 1 inch long or 0.7854 cubic inch
1 cubic inch	=	1.2732 cylindrical inches

Liquid or Fluid Measures		
4 gills (16 fluid ounces)	=	1 pint
2 pints	=	1 quart
4 quarts	=	1 gallon
31 11/32 gallons	=	1 barrel (there is no standard liquid 'barrel')
1 U.S. gallon	=	231 cubic inches or 0.13373 cubic feet
7.4805 gallons	=	1 cubic foot
When water is at its maximum density, 1 cubic foot weighs 62.428 pounds and 1 gallon weighs 8.345 pounds. For approximations, 1 cubic foot of water equals 7 1/2 gallons.		
Dry Measure		
2 pints	=	1 quart
8 quarts	=	1 peck
4 pecks	=	1 bushel
1 U.S. bushel	=	2150.42 cubic inches
	=	1.2445 cubic feet
1 cubic yard	=	21.7 U.S. bushels (approximate)
Measures of Angles or Arcs		
60 seconds (")	=	1 minute (')
60 minutes (')	=	1 degree (°)
90 degrees (°)	=	1 right angle or quadrant
360 degrees (°)	=	1 circle
Avoirdupois Weight (U.S.)		
437.5 grains (16 drams)	=	1 ounce
16 ounces	=	1 pound
100 pounds	=	1 hundred weight

GENERAL INFORMATION

2000 pounds	=	1 ton
2240 pounds	=	1 long ton

1000 kilograms (kg.)	=	1 ton (metric)
1000 cubic centimeters (cu. cm.)	=	1 cubic decimeter
1000 cubic decimeters (cu. dm.)	=	1 cubic meter

Metric Weights and Measures		
Length		
10 millimeters (mm.)	=	1 centimeter
10 centimeters (cm.)	=	1 decimeter
10 decimeters (dm.)	=	100 centimeters
	=	1 meter
1000 meters (m.)	=	1 kilometer (km.)
Area		
100 square millimeters (sq. mm.)	=	1 square centimeter
100 square centimeter (sq. cm.)	=	1 square decimeter
100 square decimeters (sq. dm.)	=	1 square meter
Volume		
1000 cubic millimeters (cu. mm.)	=	1 cubic centimeter
1000 cubic centimeters (cu. cm.)	=	1 cubic decimeter
1000 cubic decimeters (cu. dm.)	=	1 cubic meter
Capacity		
10 milliliters (ml.)	=	1 centiliter
10 centiliters (cl.)	=	1 deciliter
10 deciliters (dl.)	=	100 centiliter or 1 liter
1000 liters (l.)	=	1 kiloliter
Weight		
10 milligrams (mg.)	=	1 centigram
10 centigrams (cg.)	=	1 decigram
10 decigrams (dg.)	=	100 centigrams or 1 gram
1000 grams (g.)	=	1 kilogram

Equivalent Weights and Measures		
Length		
1 inch	=	2.54 centimeters
1 foot	=	30.48 centimeters
1 yard	=	0.9144 meters
1 mile	=	1.609 kilometers
1 centimeter	=	0.3937 inches
1 meter	=	39.37 inches or 3.281 feet
1 kilometer	=	0.6214 mile or 1093.3 yards
Area		
1 square inch	=	6.452 square centimeters
1 square foot	=	0.093 square meters
1 square yard	=	0.836 square meters
1 acre	=	4047 square meters
1 square mile	=	2.59 square kilometers
1 square centimeter	=	0.155 square inches
1 square meter	=	10.76 square feet
1 square kilometer	=	0.3861 square miles
Volume		
1 cubic inch	=	16.39 cubic centimeters
1 cubic foot	=	0.0283 cubic meters
1 cubic yard	=	0.7646 cubic meters
1 (U.S.) gallon	=	3.785 liters
1 cubic centimeter	=	0.061 cubic inches

GENERAL INFORMATION

1 cubic meter	=	35.31 cubic feet
1 liter	=	61.02 cubic inches or 0.2642 gallons
Weight		
1 ounce	=	28.35 grams
1 pound	=	0.4536 kilograms
1 ton	=	907.2 kilograms
1 gram	=	15.43 grains
1 kilogram	=	2.205 pounds
1 metric ton	=	2205 pounds

Decimal Equivalents of Parts of an Inch			
1/64	0.015625	33/64	0.515625
1/32	0.03125	17/32	0.53125
3/64	0.046875	35/64	0.546875
1/16	0.0625	9/16	0.5625
5/64	0.078125	37/64	0.578125
3/32	0.09375	19/32	0.59375
7/64	0.109375	39/64	0.609375
1/8	0.125	5/8	0.625
9/64	0.140625	41/64	0.640625
5/32	0.15625	21/32	0.65626
11/64	0.171875	43/64	0.671875
3/16	0.1875	11/16	0.6875
13/64	0.203125	45/64	0.703125
7/32	0.21875	23/32	0.71875
15/64	0.234375	47/64	0.734375
1/4	0.25	3/4	0.75
17/64	0.265625	49/64	0.765625

9/32	0.28125	25/32	0.781255
19/64	0.296875	51/64	0.796875
5/16	0.3125	13/16	0.8125
21/64	0.328125	53/64	0.828125
11/32	0.34375	27/32	0.84375
23/64	0.359375	55/64	0.859375
3/8	0.375	7/8	0.875
25/64	0.390625	57/64	0.890625
13/32	0.40625	29/32	0.90625
27/64	0.421875	59/64	0.921875
7/16	0.4375	15/16	0.9375
29/64	0.453125	61/64	0.953125
15/32	0.46875	31/32	0.96875
31/64	0.484375	63/64	0.984375
1/2	0.5	1	1.0

GENERAL INFORMATION

Approximate Weight of Materials		
Most materials and commodities vary in weight and containers vary in shape and size. Therefore it is impossible to list any but average weights per cubic foot or per unit of measurement and the following weights should be used only for approximation purposes. When it is necessary to figure weights accurately for recommendation of truck or tractor-trailer equipment, exact weights and dimensions should be obtained from local sources. This is particularly true of fruits and vegetables, containers for which vary widely in type, size and shape according to commodity and locality.		
Building Supplies, other than lumber and stone		
	Pounds per	
	Cu. Ft.	Cu. Yd.
Asbestos	153	4130
Asphalt		
Brick	125	3375
Lumps	85	2300
Paving	100	2700
Cinders	50	1350
Clay (dry lumps)	85	2300
Wet lumps	110	2970
Wet packed	135	3650
Fire	125	3375
Concrete		
Cinder or slag	120	3250
Gravel or stone	150	4050
Ave. wet mix	138	3730
Crushed stone, ave.	100	2700
Earth (loam), Loose	76	2050
Shaken	87	2350
Packed	95	2565
Moist	100	2700
Wet	125	3375
Gravel, Dry	95	2565
Wet	125	3375

	Pounds per	
	Cu. Ft.	Cu. Yd.
Motor-lime	110	2970
Rubble-dry	138	3730
Wet	154	4160
Pitch	70	1900
Plaster of Paris (gypsum)	150	4050
Quicklime, Solid	95	2550
Ground-loose	55	1485
Shaken	75	2030
Rock crushed, ave.	100	2700
Sand, Fine-dry	110	2970
Wet	125	3735
Course-dry	95	2565
Wet	120	3240
Tar	65	1755
Terra Cotta	110	2970
Tile, Solid	115	3100
Construction	40	1080
Brick		Thousand
Soft, 2.5 x 4 x 8.25		4320
Common, 2.25 x 4 x 8.25		5400
Hard, 2.25 x 4.25 x 8.5		6480
Pressed, 2.375 x 4 x 8.375		7500
Paving, 2.5 x 4 x 8.5		6750
Paving block, 3.5 x 4.5 x 8.5		8750
Fire, 2.5 x 4.5 x 9		7000
Cement block		
8 x 8 x 16	42	each
8 x 12 x 16	58	each
Cinder block		
8 x 8 x 16	35	each
8 x 12 x 16	45	each

GENERAL INFORMATION

	Pounds per	
	Cu. Ft.	Cu. Yd.
Glass Common window Plate, 1/4" thick	162 3.3	cu. ft. sq. ft.
Lime Small barrel Large barrel	210 320	barrel barrel
Farm and Dairy Products, except Fruits and Vegetables		
	Pounds	Per
Alfalfa seed	60	bushel
Barley	48	bushel
Bran	20	bushel
Buckwheat	49	bushel
Butter, 15 dia. x 15 15 dia. x 15 10.25 x 8.75 x 10.5 (30 lb.) bricks 9 lb. pail	25 70 32 10	tub tub case each
Calf, Live (avg.)	150	head
Cheese, 15 dia. x 5.25 15 dia. x 7.5 15 dia. x 15	25 35 70	box box box
Chickens Live broilers (20 avg.) Fowl (12 avg.) Std. crate, empty 24 x 35 x 13	58 78 18	crate crate each
Clover seed	60	bushel
Corn, Ear Shelled Sweet corn (green)	35 56 43	bushel bushel bushel

	Pounds	Per
Corn Meal	44	bushel
Cotton Gin bale, 20 x 48 x 54 Std. bale, 24 x 28 x 56 Comp bale, 20 x 24 x 56	515 515 515	each each each
Cotton seed	32	bushel
Cow, Live, Feeder (avg.) Butcher (avg.) Heavy steer (avg.)	600 800 1000	head head head
Eggs, 30 doz. 12 x 12 x 26	55	crate
Flax seed	56	bushel
Flour, 19 1/8 head, 30 stave	215	barrel
Hay, Baled 17 x 22 x 40 14 x 16 x 43	60 85	bale bale
Hemp seed	44	bushel
Hog, Live (avg.)	235	head
Horse, Live (avg.)	1350	head
Ice Cream 2.5 gal., 9 dia. x 11 5 gal., 9 dia. x 21	18 35	can can
Lamb, Live (avg.)	80	head
Malt, Barley Rye Brewer's grain	28 32 40	bushel bushel bushel
Millet	50	bushel
Oats	32	bushel
Popcorn, Ear Shelled	35 56	bushel bushel

GENERAL INFORMATION

	Pounds	Per
Rice, Unhulled	43	bushel
Rye	56	bushel
Sheep, Live (avg.)	138	each
Shorts	20	bushel
Soy beans	60	bushel
Straw, Baled 17 x 22 x 40	45	bale
Tallow	60	cu. ft.
Timothy seed	45	bushel
Vetch seed	60	bushel
Wheat, Bulk	60	bushel
Bag	90	1.5 bushel
Wool, Pressed	82	cu. ft.

Fruits, Vegetables and Nuts (in bulk, unless container specified)		
	Size Container	Lbs. Per Bushel or Container
Apples, Fresh	bushel	48
Western box	11.5 x 12 x 20	50
New England box	11.25 x 14.25 x 17.5	56
Standard barrel	17hc. 28.5 stone	160
Apricots, Fresh	bushel	48
Western box	5.5 x 12 x 20	23
Artichokes, Box	10 x 11.5 x 22	44
Asparagus, Pr. Crate	11.5 high 19.375 long,	
Loose	9.75 wide top,	38
Bunches	11 bottom	31
Avocados, Box	5.75 x 11.25 x 17.5	16

	Size Container	Lbs. Per Bushel or Container
Bananas, Carton	4.25 x 14.25 x 30	38
Single stem	bunch	55
Beans, Dry castor	bushel	46
White	bushel	60
Lima	bushel	56
Fresh lima	bushel	39
String	bushel	36
(Hamper) string	5 peck	45
Beets (avg.)	bushel	55
Small crate	9.75 x 13.25 x 24	50
Western crate	14 x 19 x 24.5	95
Berries, Crate 24 pt.	9.75 x 9.75 x 20	25
24 qt.	11.75 x 11.75 x 24	48
32 at.	15.5 x 11.75 x 24	63
Broccoli, Bushel Crate	12.75 x 12.75 x 17	30
Brussels sprouts, Crate	7.75 x 10.75 x 21.375	26
Cabbage, Hamper	1.5 bushel	58
Crate	12.75 x 18.5 x 19	60
Western crate	14 x 19 x 24.5	85
Bbl. crate	12.75 x 18.75 x 37.375	110
Cantaloupe, Crate		
Pony	11.75 x 11.75 x 23.5	58
Standard	12.75 x 12.75 x 23.5	68
Jumbo	13.75 x 13.75 x 23.5	78
Pony flat	4.75 x 12.75 x 23.5	26
Standard flat	5.25 x 14.25 x 23.5	28
Jumbo flat	5.75 x 15.25 x 23.5	32
Carrots, Topped	bushel	55
With tops	bushel	40
Crate	11.75 x 14.125 x 24	60

GENERAL INFORMATION

	Size Container	Lbs. Per Bushel or Container
Cauliflower Crate	bushel	30
	9.375 x 19 x 24	50
Celery, Std. Crate 1/2 crate Northern crate	11.625 x 22 x 22.625	70
	10.75 x 13 x 20.375	35
	16.5 x 21.25 x 22	85
Cherries, Unstemmed Stemmed Lug box	bushel	56
	bushel	64
	5.625 x 11.875 x 19.75	17
Chestnuts	bushel	50
Cranberries 1/4 bbl. box 1/2 bbl. box	9.5 x 11 x 14	28
	12.5 x 14.75 x 22	60
Cucumbers Crate Case	bushel	55
	9.75 x 13.75 x 24	75
	5 x 13.25 x 19	26
Eggplant, Hamper Crate	bushel	40
	14 x 11.75 x 24	54
Endive, Basket Hamper	bushel	25
	1.5 bushel	36
Grapefruit, Western box Southern box	11.5 x 11.5 x 24	68
	12.75 x 12.75 x 27	90
Grapes, Basket Lug box Western box Basket	bushel	48
	5.375 x 16.375 x 17.5	30
	15.5 x dia. x 14	45
	12 quarts	18
Greens	bushel	25
Hickory nuts	bushel	45
Horseradish roots	bushel	35
Kale	bushel	25

	Size Container	Lbs. Per Bushel or Container
Lemons, Limes, Western box Southern box	10 x 13 x 25	80
	12.75 x 12.75 x 27	90
Lentils	bushel	60
Lettuce, Hamper Hamper Basket Crate 1/2 crate	bushel	25
	1.5 bushel	38
	8.5 x 11.75 x 21.375	17
	13.75 x 17.5 x 24.5	75
Okra, Hamper Hamper	9.5 x 13.5 x 24.5	40
	.5 bushel	18
Onions, Dry, Basket Bag Crate Green with tops	bushel	55
	17 x 32	50
	20.5 x 11.5 x 10.5	58
	bushel	32
Oranges, Western box Southern box Bushel box	11.5 x 11.5 x 24	80
	12.75 x 12.75 x 27	90
	10.75 x 10.75 x 23.5	65
Parsley, Bushel Crate	12.75 x 12.75 x 17	30
Parsnips	bushel	48
Peaches, Basket Basket Crate Western box	bushel	48
	.5 bushel	25
	10.5 x 11.25 x 24	50
	5.5 x 11.25 x 24	22
Peanuts, Unshelled Bag	bushel	22
		100
Pears, Basket Western box	bushel	50
	9.625 x 12.125 x 19.75	51
Peas, Dry Fresh hamper Hamper	bushel	60
	bushel	35
	40 quarts	45

GENERAL INFORMATION

	Size Container	Lbs. Per Bushel or Container
Pecans, Large bag		100
Small bag		50
Peppers, Basket	bushel	25
Crate	14.125 x 11.75 x 24	45
Pineapples, Crate	11 x 12.5 x 36	85
Plums, Basket	bushel	56
Western box	5.625 x 16.375 x 17.5	25
Potatoes, Sweet	bushel	55
White or Irish	bushel	60
Bag	1 2/3 bushel	102
Barrel	barrel	185
Prunes, Box	5.625 x 16.375 x 17.5	25
Quinces	bushel	50
Radishes, Basket	bushel	34
Crate	9.75 x 13.75 x 24	40
Rhubarb, Box	5.125 x 11.5 x 22	24
Romaine, Crate	13.875 x 18.875 x 24.5	64
Crate	12.25 x 13 x 15.25	27
Rutabagas	bushel	56
Spinach	bushel	27
Squash	bushel	46
Sweet Corn, Basket	bushel	45
Crate	13 x 13 x 24	60
Tomatoes, Basket	bushel	55
Lug box	7.25 x 14 x 17.5	35
Crate	10.5 x 11.25 x 24	48
Basket	8.5 x 8.75 x 20	18
Turnips	bushel	54

	Size Container	Lbs. Per Bushel or Container
Walnuts, Bulk	bushel	50
Bag		100

Liquids		
	Pounds per	
	Cu. Ft.	Gallon
Acetone	50	6.6
Alcohol, commercial	51	6.8
Asphalt, hot oil	71	9.5
Carbolic acid	60	8.0
Castor oil	61	8.1
Chloroform	95	12.7
Coconut oil	58	7.8
Corn oil	58	7.8
Corn syrup	86	11.5
Cotton seed oil	58	7.8
Cream	64	8.5
Creosote	69	9.2
Crude oil	56	7.5
Ether	46	6.2
Fuel oil-Diesel	52	7.0
Fuel oil-Furnace	56	7.5
Gasoline	45	6.0
Glycerine	79	10.5
Honey	90	12.0
Kerosene	50	6.6

GENERAL INFORMATION

	Pounds per	
	Cu. Ft.	Gallon
Linseed oil	59	7.9
Lubricating	52	7.0
Maple syrup	82	11.0
Milk, bulk	64	8.6
Molasses	90	12.0
Muriatic acid, 40%	40	10.0
Naphtha, petroleum	42	5.6
Nitric acid, 91%	94	12.5
Olive oil	58	7.7
Peanut oil	57	7.6
Petroleum	56	7.5
Sorghum syrup	86	11.5
Soybean oil	58	7.7
Sugar cane syrup	85	11.3
Sulfuric acid, 87%	112	15.0
Turpentine	54	7.3
Vinegar	64	8.5
Water, fresh	63	8.4

	Size Container	Lbs. Per Container
Beer, Wood barrel	.25 barrel	
Steel barrel	.25 barrel	
Wood barrel	.25 barrel	
Steel barrel	.25 barrel	
Carton, 24 12oz.		
Regular bottles	17.25 x 11.5 x 9.875	
Steinie bottles	18.375 x 12.125 x 7.375	

	Size Container	Lbs. Per Container
Tin cans	16.25 x 11 x 5.125	
Wood case, 24 12oz.		
Regular bottles	21 x 13.5 x 10	
Steinie bottles	22 x 13.75 x 7.5	
Note: Beer cases are of many types with variable size and weight. Cases shown are average for popular full depth type with partitions.		
	Size Container	Lbs. Per Container
Milk, 5 gal. can	10.25 dia. x 19	62
10 gal. can	13 dia. x 23	115
Crate, 21.5 pt. bottles		33
20 pt. bottles		54
12 qt. bottles		64
Note: Milk bottle crates vary widely in dimensions and weights. Those shown are average weights.		
	Size Container	Lbs. Per Container
Molasses, 50 gal. bbl.	20.25 hd. 34 stave	675
	Size Container	Lbs. Per Container
Soft drinks		
Half depth bottle box		
24, 6 to 8 oz. bottles	12.25 x 18.75 x 8.5	39
Full depth bottle box		
12, 24 to 32 oz. bottles	13.375 x 18.5 x 12.25	60

GENERAL INFORMATION

Lumber, Air Dried		
Kiln dried lumber averages 10% to 15% lighter, and green lumber 40% to 50% heavier than air dried.		
	Pounds per	
	Cu. Ft.	Thousand Board Ft.
Ash, Black or Red	40	3330
White	46	3830
Bamboo	22	
Basswood	30	2500
Beech	30	2500
Birch	48	4000
Butternut	30	2500
Cedar	30	2500
Cherry	44	3670
Chestnut	37	3080
Cottonwood	37	3080
Cypress	30	2500
Elm, Soft	38	3170
Rock	45	3750
Fir, Douglas	32	2670
Eastern	25	2080
Gum	40	3330
Hemlock	29	2420
Hickory	54	4500
Locust	42	3500
Mahogany	42	3500
Maple, Hard	44	3670
Soft	34	2830

	Pounds per	
	Cu. Ft.	Thousand Board Ft.
Oak, Black	42	3500
Red	42	3500
White	48	4080
Pine, Long Leaf	44	3670
North Carolina	36	3000
Oregon	32	2670
Red	30	2500
White	26	2170
Yellow, Northern	34	2830
Southern	45	3750
Short leaf	38	3170
Long leaf	44	3670
Poplar	27	2250
Redwood	30	2500
Spruce	28	2330
Sycamore	37	3080
Walnut	43	3580
Willow	31	2580
Lath, Standard length 29 in. Put up in bundles of 50. Avg. bundle; dia. 9 in., weight 25 lbs.		
Shingles, Bundles contains the equivalent of 250 shingles, measures 24 x 20 x 10, avg. weight 50 lbs.		

Metals, Minerals, Ores, Rock, Stone, Coal		
	Pounds Per	
	Cu. Ft.	Cu. Yd.
Alabaster, gypseous	160	4320
Aluminum, pure	165	4450

GENERAL INFORMATION

	Pounds Per	
	Cu. Ft.	Cu. Yd.
Andesita stone	180	4850
Antimony	420	11650
Asbestos	153	4130
Babbit	440	11900
Barytes, mineral	280	7560
Basalt rock	185	5000
Bauxite	160	4320
Bluestone	120	3240
Borax	110	2970
Brass, Cast	525	14175
Rolled	534	14420
Drawn	542	14635
Bronze	550	14850
Chalk	137	3700
Charcoal, oak	33	890
pine	23	620
Coal, broken		
Anthracite	60	1600
Bituminous	45	1200
Pocahontas	50	1350
Cannel	50	1350
Coke	27	730
Copper, Cast	550	14850
Rolled	560	15120
Diabase	185	5000
Dolomite	181	4890
Emery	250	6750
Feldspar	160	4320

	Pounds Per	
	Cu. Ft.	Cu. Yd.
Flint	185	5000
Gneiss, Solid	160	4320
Crushed	95	2565
Granite, Solid	175	4725
Crushed	96	2590
Graphite	170	4590
Greenstone, Solid	187	5050
Crushed	107	2900
Gypsum	150	4050
Iron, Cast	450	12150
Wrought	485	13100
Hornblende	187	5050
Lead, Cast	710	19170
Limestone, Solid	166	4480
Crushed	95	2565
Magnesite	187	5050
Manganese	475	12825
Marble, Solid	165	4455
Crushed	95	2565
Marl	140	3800
Mercury	850	
Mica	185	5000
Nickel	537	14500
Ore: Most ores are 15% to 20% heavier than the rock which forms the bulk of the ore.		
Peat	50	1350
Phosphate rock	200	5400
Porcelain	150	4050

GENERAL INFORMATION

	Pounds Per	
	Cu. Ft.	Cu. Yd.
Porphyry	172	4645
Pumice	40	1080
Pyrites	315	8500
Quartz	165	4455
Rip-rap stone	65	1750
Salt, Rock, Solid	136	3670
Very coarse	35	950
Coarse	45	1215
Fine	50	1350
Barrel	280	per bbl.
Salt peter	69	1860
Sandstone, Solid	147	3970
Crushed	86	2325
Shale, Solid	172	4645
Crushed	92	2485
Silica	135	3650
Slag, Solid	175	4750
Crushed	75	2025
Screenings	100	2700
Slate	175	4725
Soapstone	169	4565
Steel, Cast	490	13250
Rolled	495	13365
Stone, Crushed, avg.	100	2700
Sulphur	125	3375
Talc	170	4600
Tin	460	12400
Trap rock	187	5050

	Pounds Per	
	Cu. Ft.	Cu. Yd.
Zinc	440	11880
Miscellaneous		
	Pounds Per	
	Cu. Ft.	Cu. Yd.
Ashes, cool (packed)	45	1215
Bone	115	3110
Cork	15	405
Furniture	6	160
Garbage		
Dry, paper wrapped	15-30	400-800
Wet	50	1240
Groceries, misc.	30	810
Ice	57	1540
Paper, Solid, avg.	58	1565
Rubber goods	94	2540
Snow, moist-packed	50	1350
Street sweepings	32	865

METRIC/U.S. CUSTOMARY CONVERSION TABLE

	Multiply	By	To Get/Multiply	By	To Get
Linear	inches inches feet	x 25.4 x 2.54 x 0.3048	millimeters (mm) centimeters (cm) meters (m)	x 0.03937 x 0.3937 x 3.281	inches inches feet
Area	square inches square inches square feet	x 645.16 x 6.452 x 0.0929	square millimeters (sq. mm) square centimeters (sq. cm) square meters (sq. m)	x 0.00155 x 0.155 x 10.764	square inches square inches square feet
Volume	cubic inches cubic inches cubic inches quarts gallons cubic feet cubic feet fluid oz.	x 16387.0 x 16.387 x 0.01639 x 0.94635 x 3.7854 x 28.317 x 0.02832 x 29.57	cubic millimeters (cu. mm) cubic centimeters (cu. cm) liters (l) liters (l) liters (l) liters (l) cubic meters (cu. m) milliliters (ml)	x 0.000061 x 0.06102 x 61.024 x 1.0567 x 0.2642 x 0.03531 x 35.315 x 0.03381	cubic inches cubic inches cubic inches quarts gallons cubic feet cubic feet fluid oz.
Mass	ounces (av) pounds (av) tons (2000 lb) tons (2000 lb)	x 28.35 x 0.4536 x 907.18 x 0.90718	grams (g) kilograms (kg) kilograms (kg) tonne (t)	x 0.03527 x 2.2046 x 0.001102 x 1.1023	ounces (av) pounds (av) tons (2000 lb) tons (2000 lb)
Fuel Economy	miles/gal gal/mile gal/mile	x 0.42514 x 2.3522 x 235.22	kilometers/liters (km/l) liters/kilometer (l/km) liters/100 kilometers (l/100 km)	x 2.3522 x 0.42514 x 0.004251	miles/gal gal/mile gal/mile
Power	horsepower ft.-lb./min	x 0.746 x 0.0226	kilowatts (kW) watts (W)	x 1.34 x 44.25	horsepower ft.-lb./min
Torque	pound-inches pound-feet	x 0.11298 x 1.3558	newton-meters (N-m) newton-meters (N-m)	x 8.851 x 0.7376	pound-inches pound-feet
Velocity	miles/hour kilometers/hour miles/hour	x 1.6093 x 0.27778 x 0.4470	kilometers/hour (km/h) meters/sec (m/s) meters/sec (m/s)	x 0.6214 x 3.600 x 2.237	miles/hour kilometers/hour miles/hour

Common Metric Prefixes

mega (M) = 1,000,000
kilo (k) = 1,000

centi (c) = 0.01
milli (m) = 0.001

hecto (h) = 100
micro (μ) = 0.000001

U.S. Imperial Gallon Comparison

1 U.S. Gallon = 0.833 Imperial Gallon
1 Imperial Gallon = 1.201 U.S. Gallon

2004 LIGHT DUTY 10/1500 — 30/3500 SERIES MODEL IDENTIFICATION SYSTEM

The designation consists of seven characters, two letters followed by five numbers. The first letter indicates the selling division and second identifies the chassis type. The first number designates the GVWR range, the second and third identify the cab-to-axle dimension (CA) or model type, and the last two identify the cab or body style.

For example:

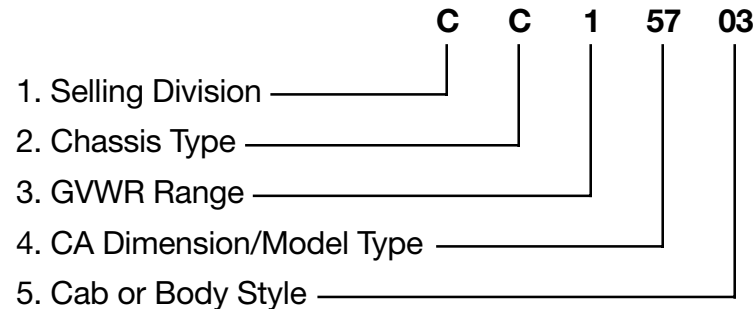

1. Selling Division

- T** – GMC Truck
 - C** – Chevrolet Truck
- ### 2. Chassis Type
- C** – Full Size Pickup/Utility/Chassis-Cab, 4 x 2 (Two-Wheel Drive)
 - K** – Full Size Pickup/Utility/Chassis-Cab, 4 x 4 (Four-Wheel Drive)
 - G** – Full Size Full Body Van/Cut-a-way, 4 x 2 (Two-Wheel Drive)
 - H** – Full Size Full Body Van, AWD (All-Wheel Drive)
 - M** – Mid-Size Van, 4 x 2 (Two-Wheel Drive)
 - L** – Mid-Size Van, AWD (All-Wheel Drive)
 - S** – Mid-Size & Small Utility/Mid-Size Pickup & Chassis-Cab, 4 x 2 (Two-Wheel Drive)

- T** – Mid-Size & Small Utility/Mid-Size & Small Pickup
- N** – Full-Size Utility, 4 x 4 (Full-Time Four-Wheel Drive)

3. GVWR Range

- 1** – 4200 to 8600
 - 2** – 7300 to 9200
 - 3** – 9900 to 12,000
- ### 4. CA Dimensions/Model Type
- 05** – Blazer (S/T Small Utility)
 - 06** – S10/Sonoma (S/T Small Pickup)
 - 10** – Astro/Safari (Mid-Size M/L Full Body Van)
 - 34** – Express/Savana (Full Size G/H Full Body Van, 135" WB)
 - 35** – Express/Savana (G Cut-a-way Van, 139" WB w/80" CA)
 - 37** – Express/Savana (Full Size G/H Full Body Van, 155" WB)

- 38** – Express/Savana (G Cut-a-way Van, 159" WB w/100" CA)
- 39** – Express/Savana (G Cut-a-way Van, 177" WB w/118" CA)
- 54** – Colorado/Canyon (S/T Mid-Size Pickup)
- 55** – Trailblazer/Envoy (Mid-Size S/T Utility) & Silverado/Sierra Short Box Crew Cab (Full-Size C/K Pickup)
- 56** – Colorado/Canyon (S/T Mid-Size Pickup & Chassis-Cab)
- 57** – Silverado/Sierra (Full-Size Pickup w/6'6" Cargo Box) & Tahoe/Yukon (Full-Size Utility) & H2 Hummer (SUV)
- 58** – TrailBlazer EXT/Envoy XL & XUV (Mid-Size S/T Utility)
- 59** – Silverado/Sierra (Full-Size Pickup w/8' Cargo Box) & Suburban/Yukon XL (Full-Size Utility)

- 60** – Silverado/Sierra (Full-Size C/K Chassis-Cab w/60" CA)
- 64** – Silverado/Sierra (Full-Size C/K Chassis-Cab w/84" CA)

5. Cab or Body Type

- 03** – Pickups & Chassis-Cab, Regular/Conventional Cab (C/K, S/T) & Cut-a-way G Van (Commercial/Motorhome)
- 05** – Full Body Cargo Van (G/H & M/L)
- 06** – Full Body Passenger Van (G/H & M/L) & 4-Door Utilities (C/K, N, S/T)
- 16** – 2-Door Utility (S/T)
- 36** – 4-Door Utility Truck w/Cargo Box (C/L & N)
- 43** – Pickup Crew Cabs (C/K, S/T)
- 53** – Pickup Extended Cabs (C/K, S/T)