

SPECIAL APPLICATIONS – FULL SIZE K SERIES (4x4)

SNOWPLOW PREP PACKAGE (VYU).....	SP— 1
Ballast Compensating Weight.....	SP— 2
‘K’ Series Snow Plow Prep Package	SP— 3
CMVSS 105 and FMVSS 105 – Hydraulic and Electric Brake Systems	SP—5
CMVSS 105 and FMVSS 105 Allowable Center of Gravity Charts.....	SP—7
CMVSS 135 and FMVSS 135 Allowable Center of Gravity Calculation.....	SP—14
CMVSS 135 and FMVSS 135 Allowable Center of Gravity Charts.....	SP—16
CMVSS 301 and FMVSS 301 – Fuel System Integrity GVRW’S.....	SB—23
‘K’ Series Snow Plow Best Practices	SP—31
‘K’ Series Snow Plow Applications Max. Plow/Hardware Weights	SP—32
ELECTRICAL INFORMATION	
Refer to Electrical - Pickups and Chassis Cabs (Chevrolet Silverado & GMC Sierra) and SUV Utilities (Chevrolet Tahoe & Suburban, GMC Yukon & Yukon XL)	

SNOWPLOW PREP PACKAGE (VYU)

The chart on the page SP-4 shows GMTG and General Motors approved models available with snowplow prep package-option VYU.

GM recommends that when a snowplow is mounted on a vehicle, only one passenger should accompany the driver. More than one passenger may exceed Front Gross Axle Weight Ratings.

Prior to installing a front mounted snowplow, the following process should be followed and necessary information obtained.

- Establish vehicle curb weight
- Establish chassis manufacturer's front and rear axle weight ratings
- Chevrolet and GMC truck dealers can provide availability, specifications, Gross Vehicle Weight Ratings (GVWR), and Front and Rear Gross Axle Weight Ratings (FGAWR/RGAWR). For vehicles already built, this information can be found on the certification label installed on driver's door/door frame or provided on the cover of the Incomplete Vehicle Document.

The following information should be obtained and provided by the manufacturers of snowplows and salt spreaders:

- Specifications, weights and center of gravity data
- Vehicle installation guidelines and instructions
- Calculation of weight distribution for the front and rear axles

The loaded vehicle with driver, passenger, aftermarket accessories, snowplows, spreader, and cargo must not exceed the Gross Vehicle Weight Rating (GVWR), and Front and Rear Gross Axle Weight Ratings. In addition, the completed curb weight vehicle, with all installed aftermarket accessories, snowplow, and spreader, and with 400 lbs. for vehicles less than 10,000 lbs. and 500 lbs. for vehicles greater than 10,000 lbs. distributed in the driver-passenger area of the vehicle, must have a center of gravity location that is located within the trapezoid formed by the coordinates A, B, C, D, H1 & H2, plus it must be to the rear of vertical line E and forward of vertical line F as defined in the ALLOWABLE CENTER OF GRAVITY CHARTS. If the center of gravity location does not fall within the specified trapezoid, ballast weight may be required to shift the center of gravity location until it falls within the specified trapezoid.

The snowplow manufacturer and the installer of the aftermarket equipment should determine the amount of rear ballast required to ensure that the vehicle, with the attached snowplow and aftermarket equipment, complies with the Allowable Center of Gravity Trapezoid and the resulting front and rear weight distribution ratio as defined in the Allowable Center of Gravity Charts published in this manual.

(Snowplow Prep Package – continued on next page)

(Snowplow Prep Package – continued from previous page)

Ballast Compensating Weight

The use of rear ballast weight may be required to prevent exceeding the Gross Axle Weight Rating of the front axle. The use of rear ballast weight may be required to ensure that the center of gravity location of the completed vehicle, with the attached snowplow and other installed equipment, complies with the Allowable Center of Gravity Trapezoid and the resulting front and rear weight distribution ratio, even though the actual front weight may be less than the Gross Axle Weight Rating of the front axle. In either case, the rear ballast weight should be securely attached in the cargo box or behind the rear axle of the vehicle in a manner which prevents it from moving during driving and stopping.



To help avoid personal injury, refer to Z-height setting procedure before adjusting torsion bars. If torsion bars are adjusted for aftermarket equipment, be sure to return them to specification when the equipment is removed. Otherwise, a front shock absorber may dislodge and damage a front brake line. This could result in an accident when minimum stopping distances are required.

SPECIAL APPLICATIONS – FULLSIZE K SERIES (4x4)

'K' – Series Snow Plow Prep Package

		PICKUPS - Single Rear Wheel (SRW)									
Model		K10703	K10903	K10753	K10953	K10543	K20753	K20743	K20903	K20953	K20943
Cab		Regular	Regular	Extended	Extended	Crew	Extended	Crew	Regular	Extended	Crew
Wheelbase inches		119	133	143.5	157.5	167	143.5	153	133	157.5	167
Pickup Box length feet / Cab to Axle length inches		6.5	8	6.5	8	8	6.5	6.5	8	8	8
GVWR lb.		6400	6400	7000	7000	7000	9500/10k*	9500/10k*	9500/9900*	9500/10k*	9900/10k*
GAWR lb. -Frt.		3950	3950	3950	3950	3950	4400/5200*	4800/5200*	4400/5200*	4800/5600*	4800/5200*
Engine Availability with VYU:		opt. code									
Vortec 4.8L V8 SFI Flex Fuel	LY20	S	S	S	N/A	S	N/A	N/A	N/A	N/A	N/A
Vortec 5.3L V8 SFI Flex Fuel	LMG / LC9	A	A	A	S	A	N/A	N/A	N/A	N/A	N/A
Vortec 6.0L V8 SFI Flex Fuel	L96	N/A	N/A	N/A	N/A	N/A	S	S	S	S	S
Vortec 6.2L V8 SFI	L9H	A	A	A	N/A	A	N/A	N/A	N/A	N/A	N/A
Duramax 6.6L V8 Diesel	LML / LGH	N/A	N/A	N/A	N/A	N/A	A	A	A	A	A
Base (B) Equipment Includes:											
Battery 600 CCA (Gasoline Engines)		S	S	S	S	S	S	S	S	S	S
Dual Batteries 730 CCA (6.6L Diesel Engine)	TUV	N/A	N/A	N/A	N/A	N/A	A	A	A	A	A
Provisions for Rear Back-Up Lighting											
Front Tow Hooks	V76	S	S	S	S	S	S	S	S	S	S
Floor Covering HD Rubber - Std. on Work Truck / Base without YE9	BG9	B & A	B & A	B & A	B & A	B & A	B & A	B & A	B & A	B & A	B & A
Snow Plow Prep Pkg. Includes:		VYU									
Increased Front Spring rate 4WD	F60	S	S	S	S	S	S	S	S	S	S
Air cleaner, high-capacity	K47	S	S	S	S	S	S	S	S	S	S
External Eng. Oil Cooler	KNP	A	A	A	A	A	R	R	R	R	R
Alternator 160 Amps - Gasoline Engines	KW1	S	S	S	S	S	S	S	S	S	S
Alternators - Dual 125 Amps - Diesel Engines	K76	N/A	N/A	N/A	N/A	N/A	S	S	S	S	S
Provision for Roof Mtd. Emergency Light	TRW	S	S	S	S	S	S	S	S	S	S
Transmission Cooler (air to oil) Auto only	KNP	S	S	S	S	S	S	S	S	S	S
***42mm Hole FOD with Rubber Grommet											
Fwd Lamp Harness with In-Line Connector											
Mntg. Location for Snow Plow Controls											
Suggested Optional Equipment :											
Battery 730 CCA - Gasoline Engines	6C5	A	A	A	A	A	A	A	A	A	A
3.73 Rear Axle Ratio	GT4	A	A	A	A	A	"B" Gas & "A" Diesel	B	B	B	B
4.10 Rear Axle Ratio	GT5	A	A	A	A	A	A	A	A	A	A
Skid Plate, "Off Road" - Included with Z71	NZZ	A & Y	A & Y	A & Y	A & Y	A & Y	A & Y	A & Y	A & Y	A & Y	A & Y
Engine Block Heater (Req'd for Canada - opt. Z49)	K05	A	A	A	A	A	A	A	A	A	A
Locking Differential - Included with (NHT) Max Trailering Pack or (PCY) Towing Package or axle ratio GT5	G80										
Rear Window Defogger (N/A with A48 on Ext. & Crew Cabs) (Reqs. C67 AC on Reg. Cabs)	C49	A	A	A	A	A	A	A	A	A	A
Sliding Rear Window not avail. with C49	A48	N/A	N/A	N/A	N/A	N/A	A	A	N/A	A	A
Windshield Washer Fluid System, Heated (Reqs. Opt. YE9 or SLT)	XA7	A	A	A	A	A	A	A	A	A	A

* = DIESEL / k = x 1000 / s = SRW / d = DRW

B=base vehicle / A=available / X=included in package / Y=included where applicable / N/A=not available on this model / R=required on this model.

SPECIAL APPLICATIONS – FULL SIZE K SERIES (4x4)

'K' – Series Snow Plow Prep Package, cont.

Model	opt. code	CKUPS - Single(s) & Dual(s) Rear Wheels				Chassis-Cabs			Utility
		K30903	K30743	K30953	K30943	K31003	K31043	K31403	K20906
Cab		Regular	Crew	Extended	Crew	Regular	Crew	Regular	SUV
Wheelbase inches		133	167	157.5	167	137	161.5	161.5	130
Pickup Box length feet / Cab to Axle length inches		8	6.5	8	8	60" CA	60" CA	80" CA	N/A
GVWR lb.		10700/11400*s 12800/13000*d	10800/11500*s 13000/13000*d 2	11000/11600*s 13000/13000*d	11000/11600*s 13000/13000*d	13,200	13,200	13,200	8600
GAWR lb. -Frt.		4400/5200*	4800/5600*	4800/5600*	4800/5600*	4400/5200*	4800/5600*	5200/5600*	4180
Engine Availability with VYU:									
Vortec 4.8L V8 SFI Flex Fuel	LY20	N/A	N/A	N/A	N/A	N/A	N/A	N/A	N/A
Vortec 5.3L V8 SFI Flex Fuel	LMG / LC9	N/A	N/A	N/A	N/A	N/A	N/A	N/A	A
Vortec 6.0L V8 SFI Flex Fuel	L96	S	S	S	S	S	S	S	S
Vortec 6.2L V8 SFI	L9H	N/A	N/A	N/A	N/A	N/A	N/A	N/A	N/A
Duramax 6.6L V8 Diesel	LML / LGH	A	A	A	A	A	A	A	N/A
Base (B) Equipment Includes:									
Battery 600 CCA (Gasoline Engines)		S	S	S	S	B	B	B	B
Dual Batteries 730 CCA (6.6L Diesel Engine)	TUV	A	A	A	A	A	A	A	N/A
Provisions for Rear Back-Up Lighting									
Front Tow Hooks	V76	S	S	S	S	S	S	S	S
Floor Covering HD Rubber - Std. on Work Truck / Base without YE9	BG9	B & A	B & A	B & A	B & A	B & A	B & A	B & A	A
Snow Plow Prep Pkg. Includes:									
Increased Front Spring rate 4WD	F60	S	S	S	S	S	S	S	N/A
Air cleaner, high-capacity	K47	S	S	S	S	S	S	S	A
External Eng. Oil Cooler	KNP	S	S	S	S	S	S	S	A
Alternator 160 Amps - Gasoline Engines	KW1	S	S	S	S	S	S	S	A
Alternators - Dual 125 Amps - Diesel Engines	K76	S	S	S	S	S	S	S	N/A
Provision for Roof Mtd. Emergency Light	TRW	S	S	S	S	S	S	S	N/A
Transmission Cooler (air to oil) Auto only	KNP	S	S	S	S	S	S	S	A
***42mm Hole FOD with Rubber Grommet									
Fwd Lamp Harness with In-Line Connector									
Mntg. Location for Snow Plow Controls									
Suggested Optional Equipment :									
Battery 730 CCA - Gasoline Engines	6C5	A	A	A	A	A	A	A	A
3.73 Rear Axle Ratio	GT4	B	B	B	B	B	B	B	B
4.10 Rear Axle Ratio	GT5	A	A	A	A	A	A	A	
Skid Plate, "Off Road" - Included with Z71	NZZ	A & Y	A & Y	A & Y	A & Y	A & Y	A & Y	A & Y	A
Engine Block Heater (Req'd for Canada - opt. Z49)	K05	A	A	A	A	A	A	A	A
Locking Differential - Included with (NHT) Max Trailering Pack or (PCY) Towing Package or axle ratio GT5	G80								
Rear Window Defogger (N/A with A48 on Ext. & Crew Cabs) (Reqs. C67 AC on Reg. Cabs)	C49	A	A	A	A	A	A	A	N/A
Sliding Rear Window not avail. with C49	A48	N/A	A	A	A	A	A	A	N/A
Windshield Washer Fluid System, Heated (Reqs. Opt. YE9 or SLT)	XA7	A	A	A	A	A	A	A	A & Y

* = DIESEL / k = x 1000 / s = SRW / d = DRW

B=base vehicle / A=available / X=included in package / Y=included where applicable / N/A=not available on this model / R=required on this model.

CMVSS 105 and FMVSS 105 – HYDRAULIC AND ELECTRIC BRAKE SYSTEMS
Applies to all types of Incomplete Vehicles Contained in this Document
Greater than 3500 kg (7,716 lb) GVWR

TYPE 2 The following statement is applicable to all types of Incomplete Vehicles contained in this document with a greater than 3500 kg (7,716 lb) GVWR, (unless otherwise noted on the cover).

This incomplete vehicle when completed will conform to CMVSS 105 and FMVSS 105 provided it is completed in accordance with the following specific conditions by the (intermediate and) final stage manufacturer:

A. Providing no alterations are made which affect the function, physical, chemical, or mechanical properties, environment, location or vital spatial clearances of the components, assemblies or systems, as manufactured by General Motors, including but not limited to those listed below (if equipped):

Anti-Lock Brake System	Hydraulic brake lines, fittings and routings
Brake assemblies and components (service/ parking) - (power boosters, master cylinder, wheel cylinder, calipers, wheel speed sensor, wheel speed sensor wiring, brake lining, etc.)	Hydraulic brake valves and components
Brake pedal, brake switch, parking brake hand lever or park brake switch and related mechanical components	Master cylinder-warning statement
Brake system electrical controls and logic	Parking brake actuator and related mechanical components
Gauges and warning devices, and statements	Power steering or vacuum lines and routing
Hydraulic brake fluid and reservoirs	Power steering or vacuum pump
	Tires and Wheels
	Vacuum brake lines, fittings and routings
	Vehicle wiring harnesses
	Wheelbases

B. GVWR, GAWR front and rear weight ratings as listed on the Incomplete Vehicle Label affixed to the front cover of this document must not be exceeded.

C. The center of gravity of the total vehicle falls within the areas referenced on the “ALLOWABLE CENTER OF GRAVITY CHART” that follows. Instructions for determining the allowable center of gravity variation are listed below:

These charts detail the envelope of allowable center of gravity variation for completed vehicles. This is significant for the lightly loaded portion of FMVSS 105, which is defined as curb plus 181.4 kg (400 lb) distributed in the driver-passenger area of the vehicle for vehicles with GVWR of 4536 kg (10,000 lb) or less or as curb plus 226.8 kg (500 lb) distributed in the driver-passenger area of the vehicle for vehicles with GVWR greater than 4536 kg (10,000 lb).

The lightly loaded center of gravity of complete vehicles needs to be restricted so it will meet FMVSS 105 stopping distances. The laden center of gravity does not need to be specified as it is controlled within the CMVSS 105 and FMVSS 105 test procedure by specific instructions as to how ballast is to be placed (while height is not controlled, it is assumed that for test purposes it would be reasonable).

CMVSS 105 and FMVSS 105 – HYDRAULIC AND ELECTRIC BRAKE SYSTEMS
Applies to all types of Incomplete Vehicles Contained in this Document
Greater than 3500 kg (7,716 lb) GVWR

For Body Builder's use, the center of gravity location can be approximated by the following formula:

$$d = \frac{[Wrc + Wrb + [(Hp)(Wp)/WB]] WB}{Wt}$$

$$h = \frac{[h1Wc + h2Wb + (h3)(Wp)]}{Wt}$$

d = horizontal distance from front wheels to completed vehicle center of gravity mm (in)

h = vertical distance from ground to completed vehicle center of gravity mm (in)

Wrc = rear component of Chassis weight kg (lb)

Wrb = rear component of body weight kg (lb)

WB = vehicle wheelbase mm (in)

Wt = total weight of chassis and body kg (lb) plus 181.4 kg (400 lb) for vehicles with GVWR of 4536 kg (10,000 lb) or less.

Wt = total weight of chassis and body kg (lb) plus 226.8 kg (500 lb) for vehicles with GVWR greater than 4536 kg (10,000 lb).

h1 = center of gravity height from ground of the Bare Chassis = 743 mm (29.25 in)

Wc = total weight of Chassis kg (lb)

h2 = center of gravity height of body from ground mm (in)

Wb = total weight of body kg (lb)

Wp = 181.4 kg (400 lb) Amount from lightly loaded definition that is evenly distributed in driver-passenger area of vehicle for vehicles with GVWR of 4536 kg (10,000 lb) or less.

Wp = 226.8 kg (500 lb) Amount from lightly loaded definition that is evenly distributed in driver-passenger area of vehicle for vehicles with GVWR greater than 4536 kg (10,000 lb).

Hp = 1482 mm (58.35 in) Horizontal distance from front axle to center of gravity of 181.4 kg (400 lb) or 226.8 kg (500 lb) evenly distributed in driver-passenger area of vehicle.

h3 = 1013 mm (39.88 in) Vertical center of gravity height of 181.4 kg (400 lb) evenly distributed in driver-passenger area for vehicles with GVWR of 4536 kg (10,000 lb) or less.

h3 = 1013 mm (39.88 in) Vertical center of gravity height of 226.8 kg (500 lb) evenly distributed in driver-passenger area for vehicles with GVWR greater than 4536 kg (10,000 lb).

SPECIAL APPLICATIONS – FULL SIZE K SERIES (4x4)

CMVSS 105 and FMVSS 105 ALLOWABLE CENTER OF GRAVITY CHARTS

Model	GVWR kg (lb)	Brake System	Wheel- Base mm (in)	Rear Wheel	Incomplete, Pickup Box Removal, or Snow Plow Prep Package Vehicles							
					Coordinates of Allowable C/G Variation at CMVSS/FMVSS Unladen, Curb Weight + 181.4 kg (400 lb) or 226.8 kg (500 lb) as defined by CMVSS 105 and FMVSS 105						Fwd C/G Limit mm (in)	RRwd C/G Limit mm (in)
					mm (in)						E	F
H ₁	H ₂	A	B	C	D							
C20743	4309 (9500)	J95	3904 (153.7)	SRW	304.8 (12.0)	1219.2 (48.0)	1288 (50.7)	1542 (60.7)	2785 (109.6)	3039 (119.6)	1288 (50.7)	2733 (107.6)
C20743	4491 (9900)	J95	3904 (153.7)	SRW	304.8 (12.0)	1219.2 (48.0)	1288 (50.7)	1542 (60.7)	2785 (109.6)	3039 (119.6)	1288 (50.7)	2733 (107.6)
C20743	4536 (10,000)	J95	3904 (153.7)	SRW	304.8 (12.0)	1219.2 (48.0)	1288 (50.7)	1542 (60.7)	2785 (109.6)	3039 (119.6)	1288 (50.7)	2733 (107.6)
C20753	4309 (9500)	J95	3662 (144.2)	SRW	304.8 (12.0)	1219.2 (48.0)	1213 (47.8)	1467 (57.8)	2618 (103.1)	2871 (113.0)	1209 (47.6)	2564 (100.9)
C20753	4491 (9900)	J95	3662 (144.2)	SRW	304.8 (12.0)	1219.2 (48.0)	1213 (47.8)	1467 (57.8)	2618 (103.1)	2871 (113.0)	1209 (47.6)	2564 (100.9)
C20753	4536 (10,000)	J95	3662 (144.2)	SRW	304.8 (12.0)	1219.2 (48.0)	1213 (47.8)	1467 (57.8)	2618 (103.1)	2871 (113.0)	1209 (47.6)	2564 (100.9)
C20903	4218 (9300)	J95	3395 (133.7)	SRW	304.8 (12.0)	1219.2 (48.0)	1131 (44.5)	1385 (54.5)	2433 (95.8)	2687 (105.8)	1120 (44.1)	2377 (93.6)
C20903	4491 (9900)	J95	3395 (133.7)	SRW	304.8 (12.0)	1219.2 (48.0)	1131 (44.5)	1385 (54.5)	2433 (95.8)	2687 (105.8)	1120 (44.1)	2377 (93.6)
C20903	4536 (10,000)	J95	3395 (133.7)	SRW	304.8 (12.0)	1219.2 (48.0)	1131 (44.5)	1385 (54.5)	2433 (95.8)	2687 (105.8)	1120 (44.1)	2377 (93.6)
C20943	4309 (9500)	J95	4259 (157.7)	SRW	304.8 (12.0)	1219.2 (48.0)	1397 (55.0)	1651 (65.0)	3031 (119.3)	3284 (129.3)	1406 (55.4)	2982 (117.4)
C20943	4491 (9900)	J95	4259 (157.7)	SRW	304.8 (12.0)	1219.2 (48.0)	1397 (55.0)	1651 (65.0)	3031 (119.3)	3284 (129.3)	1406 (55.4)	2982 (117.4)
C20943	4536 (10,000)	J95	4259 (157.7)	SRW	304.8 (12.0)	1219.2 (48.0)	1397 (55.0)	1651 (65.0)	3031 (119.3)	3284 (129.3)	1406 (55.4)	2982 (117.4)
C20953	4309 (9500)	J95	4017 (158.2)	SRW	304.8 (12.0)	1219.2 (48.0)	1323 (52.1)	1576 (62.0)	2863 (112.7)	3117 (122.7)	1326 (52.2)	2812 (110.7)

SPECIAL APPLICATIONS – FULL SIZE K SERIES (4x4)

CMVSS 105 and FMVSS 105 ALLOWABLE CENTER OF GRAVITY CHARTS

Model	GVWR kg (lb)	Brake System	Wheel- Base mm (in)	Rear Wheel	Incomplete, Pickup Box Removal, or Snow Plow Prep Package Vehicles							
					Coordinates of Allowable C/G Variation at CMVSS/FMVSS Unladen, Curb Weight + 181.4 kg (400 lb) or 226.8 kg (500 lb) as defined by CMVSS 105 and FMVSS 105 mm (in)						Fwd C/G Limit mm (in)	RRwd C/G Limit mm (in)
					H ₁	H ₂	A	B	C	D	E	F
C20953	4491 (9900)	J95	4017 (158.2)	SRW	304.8 (12.0)	1219.2 (48.0)	1323 (52.1)	1576 (62.0)	2863 (112.7)	3117 (122.7)	1326 (52.2)	2812 (110.7)
C20953	4536 (10,000)	J95	4017 (158.2)	SRW	304.8 (12.0)	1219.2 (48.0)	1323 (52.1)	1576 (62.0)	2863 (112.7)	3117 (122.7)	1326 (52.2)	2812 (110.7)
C30743	4536 (10,000)	J95	3904 (153.7)	SRW	304.8 (12.0)	1219.2 (48.0)	1288 (50.7)	1542 (60.7)	2785 (109.6)	3039 (119.6)	1288 50.7	2733 (107.6)
C30743	4763 (10,500)	J95	3904 (153.7)	SRW	304.8 (12.0)	1219.2 (48.0)	1074 (42.3)	1286 (50.6)	2971 (117.0)	3182 (125.3)	1171 (46.1)	2928 (115.3)
C30743	5035 (11,100)	J95	3904 (153.7)	SRW	304.8 (12.0)	1219.2 (48.0)	1074 (42.3)	1286 (50.6)	2971 (117.0)	3182 (125.3)	1171 (46.1)	2928 (115.3)
C30903	4717 (10,400)	J95	3395 (133.7)	SRW	304.8 (12.0)	1219.2 (48.0)	943 (37.1)	1155 (45.5)	2593 (102.1)	2804 (110.4)	1019 (40.1)	2547 (100.3)

SPECIAL APPLICATIONS – FULL SIZE K SERIES (4x4)

CMVSS 105 and FMVSS 105 ALLOWABLE CENTER OF GRAVITY CHARTS

Model	GVWR kg (lb)	Brake System	Wheel- Base mm (in)	Rear Wheel	Incomplete, Pickup Box Removal, or Snow Plow Prep Package Vehicles							
					Coordinates of Allowable C/G Variation at CMVSS/FMVSS Unladen, Curb Weight + 181.4 kg (400 lb) or 226.8 kg (500 lb) as defined by CMVSS 105 and FMVSS 105						Fwd C/G Limit mm (in)	RRwd C/G Limit mm (in)
					H ₁	H ₂	A	B	C	D	E	F
C30903	5035 (11,100)	J95	3395 (133.7)	SRW	304.8 (12.0)	1219.2 (48.0)	943 (37.1)	1155 (45.5)	2593 (102.1)	2804 (110.4)	1019 (40.1)	2547 (100.3)
C30903	5670 (12,500)	J96	3395 (133.7)	DRW	304.8 (12.0)	1219.2 (48.0)	943 (37.1)	1155 (45.5)	2593 (102.1)	2804 (110.4)	1019 (40.1)	2547 (100.3)
C30903	5806 (12,800)	J96	3395 (133.7)	DRW	304.8 (12.0)	1219.2 (48.0)	943 (37.1)	1155 (45.5)	2593 (102.1)	2804 (110.4)	1019 (40.1)	2547 (100.3)
C30903	5897 (13,000)	J96	3395 (133.7)	DRW	304.8 (12.0)	1219.2 (48.0)	943 (37.1)	1155 (45.5)	2593 (102.1)	2804 (110.4)	1019 (40.1)	2547 (100.3)
C30903	6078 (13,400)	J96	3395 (133.7)	DRW	304.8 (12.0)	1219.2 (48.0)	943 (37.1)	1155 (45.5)	2593 (102.1)	2804 (110.4)	1019 (40.1)	2547 (100.3)
C30943	4536 (10,000)	J95	4259 (157.7)	SRW	304.8 (12.0)	1219.2 (48.0)	1397 (55.0)	1651 (65.0)	3031 (119.3)	3284 (129.3)	1406 (55.4)	2982 (117.4)
C30943	4853 (10,700)	J95	4259 (157.7)	SRW	304.8 (12.0)	1219.2 (48.0)	1165 (45.9)	1377 (54.2)	3235 (127.4)	3446 (135.7)	1278 (50.3)	3195 (125.8)
C30943	5171 (11,400)	J95	4259 (157.7)	SRW	304.8 (12.0)	1219.2 (48.0)	1165 (45.9)	1377 (54.2)	3235 (127.4)	3446 (135.7)	1278 (50.3)	3195 (125.8)
C30943	5897 (13,000)	J96	4259 (157.7)	DRW	304.8 (12.0)	1219.2 (48.0)	1165 (45.9)	1377 (54.2)	3235 (127.4)	3446 (135.7)	1278 (50.3)	3195 (125.8)
C30953	4536 (10,000)	J95	4017 (158.2)	SRW	304.8 (12.0)	1219.2 (48.0)	1323 (52.1)	1576 (62.0)	2863 (112.7)	3117 (122.7)	1326 (52.2)	2812 (110.7)
C30953	4853 (10,700)	J95	4017 (158.2)	SRW	304.8 (12.0)	1219.2 (48.0)	1103 (43.4)	1315 (51.8)	3055 (120.3)	3266 (128.6)	1205 (47.4)	3013 (118.6)
C30953	5080 (11,200)	J95	4017 (158.2)	SRW	304.8 (12.0)	1219.2 (48.0)	1103 (43.4)	1315 (51.8)	3055 (120.3)	3266 (128.6)	1205 (47.4)	3013 (118.6)
C30953	5897 (13,000)	J96	4017 (158.2)	DRW	304.8 (12.0)	1219.2 (48.0)	1103 (43.4)	1315 (51.8)	3055 (120.3)	3266 (128.6)	1205 (47.4)	3013 (118.6)

SPECIAL APPLICATIONS – FULL SIZE K SERIES (4x4)

CMVSS 105 and FMVSS 105 ALLOWABLE CENTER OF GRAVITY CHARTS

Model	GVWR kg (lb)	Brake System	Wheel- Base mm (in)	Rear Wheel	Incomplete, Pickup Box Removal, or Snow Plow Prep Package Vehicles							
					Coordinates of Allowable C/G Variation at CMVSS/FMVSS Unladen, Curb Weight + 181.4 kg (400 lb) or 226.8 kg (500 lb) as defined by CMVSS 105 and FMVSS 105 mm (in)						Fwd C/G Limit mm (in)	RRwd C/G Limit mm (in)
					H ₁	H ₂	A	B	C	D	E	F
C31003	5987 (13,200)	J90	3493 (137.5)	DRW	304.8 (12.0)	1219.2 (48.0)	968 (38.1)	1180 (46.5)	2441 (96.1)	2759 (108.6)	1048 (41.3)	2619 (103.1)
C31003	5987 (13,200)	J96	3493 (137.5)	DRW	304.8 (12.0)	1219.2 (48.0)	968 (38.1)	1180 (46.5)	2666 (105.0)	2877 (113.3)	1048 (41.3)	2619 (103.1)
C31043	5987 (13,200)	J96	4356 (171.5)	DRW	304.8 (12.0)	1219.2 (48.0)	1190 (46.9)	1402 (55.2)	3307 (130.2)	3518 (138.5)	1307 (51.5)	3267 (128.6)
C31403	5987 (13,200)	J96	4115 (162.0)	DRW	304.8 (12.0)	1219.2 (48.0)	1128 (44.4)	1340 (52.8)	3128 (123.1)	3339 (131.5)	1234 (48.6)	3086 (121.5)
K20743	4309 (9500)	J95	3904 (153.7)	SRW	304.8 (12.0)	1219.2 (48.0)	1288 (50.7)	1542 (60.7)	2785 (109.6)	3039 (119.6)	1288 50.7)	2733 (107.6)
K20743	4491 (9900)	J95	3904 (153.7)	SRW	304.8 (12.0)	1219.2 (48.0)	1288 (50.7)	1542 (60.7)	2785 (109.6)	3039 (119.6)	1288 50.7)	2733 (107.6)
K20743	4536 (10,000)	J95	3904 (153.7)	SRW	304.8 (12.0)	1219.2 (48.0)	1288 (50.7)	1542 (60.7)	2785 (109.6)	3039 (119.6)	1288 50.7)	2733 (107.6)
K20753	4309 (9500)	J95	3662 (144.2)	SRW	304.8 (12.0)	1219.2 (48.0)	1213 (47.8)	1467 (57.8)	2618 (103.1)	2871 (113.0)	1209 (47.6)	2564 (100.9)
K20753	4491 (9900)	J95	3662 (144.2)	SRW	304.8 (12.0)	1219.2 (48.0)	1213 (47.8)	1467 (57.8)	2618 (103.1)	2871 (113.0)	1209 (47.6)	2564 (100.9)

SPECIAL APPLICATIONS – FULL SIZE K SERIES (4x4)

CMVSS 105 and FMVSS 105 ALLOWABLE CENTER OF GRAVITY CHARTS

Model	GVWR kg (lb)	Brake System	Wheel- Base mm (in)	Rear Wheel	Incomplete, Pickup Box Removal, or Snow Plow Prep Package Vehicles							
					Coordinates of Allowable C/G Variation at CMVSS/FMVSS Unladen, Curb Weight + 181.4 kg (400 lb) or 226.8 kg (500 lb) as defined by CMVSS 105 and FMVSS 105 mm (in)						Fwd C/G Limit mm (in)	RRwd C/G Limit mm (in)
					H ₁	H ₂	A	B	C	D	E	F
K20753	4536 (10,000)	J95	3662 (144.2)	SRW	304.8 (12.0)	1219.2 (48.0)	1213 (47.8)	1467 (57.8)	2618 (103.1)	2871 (113.0)	1209 (47.6)	2564 (100.9)
K20903	4309 (9500)	J95	3395 (133.7)	SRW	304.8 (12.0)	1219.2 (48.0)	1131 (44.5)	1385 (54.5)	2433 (95.8)	2687 (105.8)	1120 (44.1)	2377 (93.6)
K20903	4491 (9900)	J95	3395 (133.7)	SRW	304.8 (12.0)	1219.2 (48.0)	1131 (44.5)	1385 (54.5)	2433 (95.8)	2687 (105.8)	1120 (44.1)	2377 (93.6)
K20943	4491 (9900)	J95	4259 (157.7)	SRW	304.8 (12.0)	1219.2 (48.0)	1397 (55.0)	1651 (65.0)	3031 (119.3)	3284 (129.3)	1406 (55.4)	2982 (117.4)
K20943	4536 (10,000)	J95	4259 (157.7)	SRW	304.8 (12.0)	1219.2 (48.0)	1397 (55.0)	1651 (65.0)	3031 (119.3)	3284 (129.3)	1406 (55.4)	2982 (117.4)
K20953	4309 (9500)	J95	4017 (158.2)	SRW	304.8 (12.0)	1219.2 (48.0)	1323 (52.1)	1576 (62.0)	2863 (112.7)	3117 (122.7)	1326 (52.2)	2812 (110.7)
K20953	4491 (9900)	J95	4017 (158.2)	SRW	304.8 (12.0)	1219.2 (48.0)	1323 (52.1)	1576 (62.0)	2863 (112.7)	3117 (122.7)	1326 (52.2)	2812 (110.7)
K20953	4536 (10,000)	J95	4017 (158.2)	SRW	304.8 (12.0)	1219.2 (48.0)	1323 (52.1)	1576 (62.0)	2863 (112.7)	3117 (122.7)	1326 (52.2)	2812 (110.7)
K30743	4536 (10,000)	J95	3904 (153.7)	SRW	304.8 (12.0)	1219.2 (48.0)	1288 (50.7)	1542 (60.7)	2785 (109.6)	3039 (119.6)	1288 50.7)	2733 (107.6)
K30743	4899 (10,800)	J95	3904 (153.7)	SRW	304.8 (12.0)	1219.2 (48.0)	1074 (42.3)	1286 (50.6)	2971 (117.0)	3182 (125.3)	1171 (46.1)	2928 (115.3)
K30743	5216 (11,500)	J95	3904 (153.7)	SRW	304.8 (12.0)	1219.2 (48.0)	1074 (42.3)	1286 (50.6)	2971 (117.0)	3182 (125.3)	1171 (46.1)	2928 (115.3)
K30903	4536 (10,000)	J95	3395 (133.7)	SRW	304.8 (12.0)	1219.2 (48.0)	1131 (44.5)	1385 (54.5)	2433 (95.8)	2687 (105.8)	1120 (44.1)	2377 (93.6)

SPECIAL APPLICATIONS – FULL SIZE K SERIES (4x4)

CMVSS 105 and FMVSS 105 ALLOWABLE CENTER OF GRAVITY CHARTS

Model	GVWR kg (lb)	Brake System	Wheel- Base mm (in)	Rear Wheel	Incomplete, Pickup Box Removal, or Snow Plow Prep Package Vehicles							
					Coordinates of Allowable C/G Variation at CMVSS/FMVSS Unladen, Curb Weight + 181.4 kg (400 lb) or 226.8 kg (500 lb) as defined by CMVSS 105 and FMVSS 105 mm (in)						Fwd C/G Limit mm (in)	RRwd C/G Limit mm (in)
					H ₁	H ₂	A	B	C	D	E	F
K30903	4853 (10,700)	J95	3395 (133.7)	SRW	304.8 (12.0)	1219.2 (48.0)	943 (37.1)	1155 (45.5)	2593 (102.1)	2804 (110.4)	1019 (40.1)	2547 (100.3)
K30903	5171 (11,400)	J95	3395 (133.7)	SRW	304.8 (12.0)	1219.2 (48.0)	943 (37.1)	1155 (45.5)	2593 (102.1)	2804 (110.4)	1019 (40.1)	2547 (100.3)
K30903	5806 (12,800)	J96	3395 (133.7)	DRW	304.8 (12.0)	1219.2 (48.0)	943 (37.1)	1155 (45.5)	2593 (102.1)	2804 (110.4)	1019 (40.1)	2547 (100.3)
K30903	5897 (13,000)	J96	3395 (133.7)	DRW	304.8 (12.0)	1219.2 (48.0)	943 (37.1)	1155 (45.5)	2593 (102.1)	2804 (110.4)	1019 (40.1)	2547 (100.3)
K30943	4989 (11,000)	J95	4259 (157.7)	SRW	304.8 (12.0)	1219.2 (48.0)	1165 (45.9)	1377 (54.2)	3235 (127.4)	3446 (135.7)	1278 (50.3)	3195 (125.8)
K30943	5262 (11,600)	J95	4259 (157.7)	SRW	304.8 (12.0)	1219.2 (48.0)	1165 (45.9)	1377 (54.2)	3235 (127.4)	3446 (135.7)	1278 (50.3)	3195 (125.8)
K30943	5897 (13,000)	J96	4259 (157.7)	DRW	304.8 (12.0)	1219.2 (48.0)	1165 (45.9)	1377 (54.2)	3235 (127.4)	3446 (135.7)	1278 (50.3)	3195 (125.8)
K30953	4536 (10,000)	J95	4017 (158.2)	SRW	304.8 (12.0)	1219.2 (48.0)	1323 (52.1)	1576 (62.0)	2863 (112.7)	3117 (122.7)	1326 (52.2)	2812 (110.7)
K30953	4989 (11,000)	J95	4017 (158.2)	SRW	304.8 (12.0)	1219.2 (48.0)	1103 (43.4)	1315 (51.8)	3055 (120.3)	3266 (128.6)	1205 (47.4)	3013 (118.6)
K30953	5262 (11,600)	J95	4017 (158.2)	SRW	304.8 (12.0)	1219.2 (48.0)	1103 (43.4)	1315 (51.8)	3055 (120.3)	3266 (128.6)	1205 (47.4)	3013 (118.6)

SPECIAL APPLICATIONS – FULL SIZE K SERIES (4x4)

CMVSS 105 and FMVSS 105 ALLOWABLE CENTER OF GRAVITY CHARTS

Model	GVWR kg (lb)	Brake System	Wheel- Base mm (in)	Rear Wheel	Incomplete, Pickup Box Removal, or Snow Plow Prep Package Vehicles							
					Coordinates of Allowable C/G Variation at CMVSS/FMVSS Unladen, Curb Weight + 181.4 kg (400 lb) or 226.8 kg (500 lb) as defined by CMVSS 105 and FMVSS 105						Fwd C/G Limit mm (in)	RRwd C/G Limit mm (in)
					mm (in)						E	F
H ₁	H ₂	A	B	C	D							
K30953	5897 (13,000)	J96	4017 (158.2)	DRW	304.8 (12.0)	1219.2 (48.0)	1103 (43.4)	1315 (51.8)	3055 (120.3)	3266 (128.6)	1205 (47.4)	3013 (118.6)
K31003	5987 (13,200)	J96	3493 (137.5)	DRW	304.8 (12.0)	1219.2 (48.0)	968 (38.1)	1180 (46.5)	2666 (105.0)	2877 (113.3)	1048 (41.3)	2619 (103.1)
K31043	5987 (13,200)	J96	4356 (171.5)	DRW	304.8 (12.0)	1219.2 (48.0)	1190 (46.9)	1402 (55.2)	3307 (130.2)	3518 (138.5)	1307 (51.5)	3267 (128.6)
K31403	5987 (13,200)	J96	4115 (162.0)	DRW	304.8 (12.0)	1219.2 (48.0)	1128 (44.4)	1340 (52.8)	3128 (123.1)	3339 (131.5)	1234 (48.6)	3086 (121.5)

SRW = Single Rear Wheel
 DRW = Dual Rear Wheel
 C/G = Center of Gravity
 Brake Systems: Hydraulic Powered Boosters – J90, J95, J96

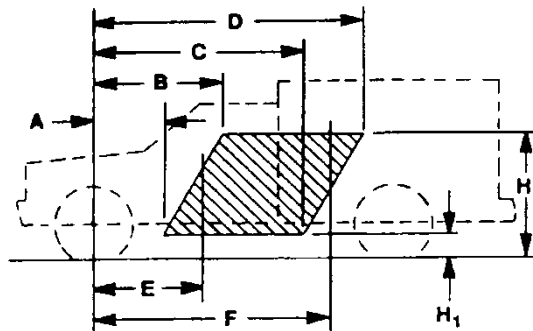

C/G of vehicle in CMVSS or FMVSS unladen condition [Curb + 181.4 kg. (400 lb) or Curb + 226.8 kg. (500 lb) as defined by CMVSS 105 and FMVSS 105] must be inside shaded area – that is, the C/G must be within the trapezoid formed by the coordinates A, B, C, D, H1, & H2, plus the C/G must be to the rear of vertical line E and forward of vertical line F.

CMVSS135 and FMVSS135 Allowable Center of Gravity Calculation

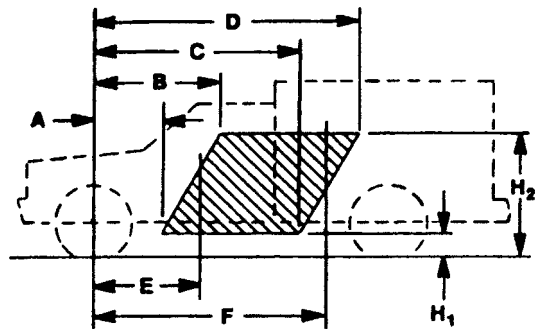

C/G of vehicle in CMVSS or FMVSS unladen condition [Curb + 181.4 kg. (400 lb)] must be inside shaded area – that is, the C/G must be within the trapezoid formed by the coordinates A, B, C, D, H₁, & H₂, plus the C/G must be to the rear of vertical line E and forward of vertical line F.

The center of gravity of the total vehicle falls within the areas referenced on the “ALLOWABLE CENTER OF GRAVITY CHART” that follows. Instructions for determining the allowable center of gravity variation are listed below:

These charts detail the envelope of allowable center of gravity variation for completed vehicles. This is significant for the lightly loaded portion of CMVSS 135 and FMVSS 135, which is defined as curb plus 181.4 kg (400 lb) distributed in the driver-passenger area of the vehicle.

The lightly loaded center of gravity complete vehicles needs to be restricted so it will meet CMVSS 135 and FMVSS 135 stopping distances. The laden center of gravity does not need to be specified as it is controlled within the CMVSS 135 and FMVSS 135 test procedure by specific instructions as to how ballast is to be placed (while height is not controlled, it is assumed that for test purposes it would be reasonable).

For Body Builder’s use, the center of gravity location can be approximated by the following formula:

$$d = \frac{[W_{rc} + W_{rb} + [(H_p)(W_p)/WB]] WB}{W_t}$$

$$h = \frac{[h_1 W_c + h_2 W_b + (h_3)(W_p)]}{W_t}$$

d = horizontal distance from front wheels to completed vehicle center of gravity cm (in)

h = vertical distance from ground to completed vehicle center of gravity cm (in)

W_{rc} = rear component of bare chassis weight kg (lb)

W_{rb} = rear component of body weight kg (lb)

(continued on next page)

CMVSS135 and FMVSS135 Allowable Center of Gravity Calculation (continued)

- WB = vehicle wheelbase cm (in)
- W_t = total weight of chassis and body kg (lbs) plus 181.4 kg (400 lb)
- h_1 = center of gravity height from ground of the bare chassis = 71.1 cm (28 in)
- W_c = total weight of chassis kg (lb)
- h_2 = center of gravity height of body from ground cm (in)
- W_b = total weight of body kg (lb)
- W_p = 181.4 kg (400 lb) amount from lightly loaded definition that is evenly distributed in driver-passenger area of vehicle
- H_p = 146.7 cm (57.76 in) horizontal distance from front axle to center of gravity of 181.4 kg (400 lb) evenly distributed in driver-passenger area of vehicle
- h_3 = 94.8 cm (37.72 in) vertical center of gravity height of 181.4 kg (400 lb) evenly distributed in driver-passenger area for vehicles with 3500 kg (7716 lb) GVWR or less

NOTE: An alternate method of center of gravity calculation may be found in the current issue of the General Motors Body Builders Book in the general instruction section and in SVIE Bulletin #39.

CMVSS135 and FMVSS135 Allowable Center of Gravity Charts

Model	GVWR kg (lb)	Brake System	Wheel- Base mm (in)	Rear Wheel	Incomplete, Pickup Box Removal, or Snow Plow Prep Package Vehicles							
					Coordinates of Allowable C/G Variation at CMVSS/FMVSS Unladen, Curb Weight + 181.4 kg (400 lb) mm (in)						Fwd C/G Limit mm (in)	RRwd C/G Limit mm (in)
					H ₁	H ₂	A	B	C	D	E	F
C10703	2903 (6400)	JF7	3022.6 (119.0)	SRW	305 (12.0)	1219 (48.0)	904 (35.6)	1585 (62.4)	1387 (54.6)	2078 (81.8)	1041 (41.0)	2078 (81.8)
C10903	2903 (6400)	JF7	3378.2 (133.0)	SRW	305 (12.0)	1219 (48.0)	980 (38.6)	1661 (65.4)	1539 (60.6)	2215 (87.2)	1143 (45.0)	2215 (87.2)
C10553	2903 (6400)	JF7	3401.1 (133.9)	SRW	305 (12.0)	1219 (48.0)	986 (38.8)	1666 (65.6)	1549 (61.0)	2230 (87.8)	1143 (45.0)	2230 (87.8)
C10753	2903 (6400)	JF7	3644.9 (143.5)	SRW	305 (12.0)	1219 (48.0)	1046 (41.2)	1717 (67.6)	1649 (64.8)	2316 (91.2)	1219 (48.0)	2316 (91.2)
K10703	2903 (6400)	JF7	3022.6 (119.0)	SRW	305 (12.0)	1219 (48.0)	904 (35.6)	1585 (62.4)	1397 (55.0)	2078 (81.8)	1041 (41.0)	2078 (81.8)
K10903	2903 (6400)	JF7	3378.2 (133.0)	SRW	305 (12.0)	1219 (48.0)	980 (38.6)	1661 (65.4)	1539 (60.6)	2215 (87.2)	1143 (45.0)	2215 (87.2)
C10553	2994 (6600)	JF3 ABS	3401.1 (133.9)	SRW	305 (12.0)	1219 (48.0)	945 (37.2)	1631 (64.2)	1656 (65.2)	2332 (91.8)	1143 (45.0)	2332 (91.8)
C10753	3084 (6800)	JF3 ABS	3649.0 (143.9)	SRW	305 (12.0)	1219 (48.0)	975 (38.4)	1661 (65.4)	1758 (69.2)	2433 (95.8)	1219 (48.0)	2433 (95.8)
C10953	3130 (6900)	JF3 ABS	4000.5 (157.5)	SRW	305 (12.0)	1219 (48.0)	1046 (41.2)	1722 (67.8)	1910 (75.2)	2586 (101.8)	1346 (53.0)	2586 (101.8)
K10903	3184 (6800)	JF3 ABS	3378.2 (133.0)	SRW	305 (12.0)	1219 (48.0)	925 (36.4)	1504 (59.2)	1646 (64.8)	2322 (91.4)	1143 (45.0)	2322 (91.4)
K10553	3084 (6800)	JF3 ABS	3401.1 (133.9)	SRW	305 (12.0)	1219 (48.0)	930 (36.6)	1610 (63.4)	1656 (65.2)	2332 (91.8)	1143 (45.0)	2332 (91.8)
K10753	3175 (7000)	JF3 ABS	3644.9 (143.5)	SRW	305 (12.0)	1219 (48.0)	965 (38.0)	1636 (64.4)	1758 (69.2)	2433 (95.8)	1219 (48.0)	2433 (95.8)
K10953	3175 (7000)	JF3 ABS	4000.5 (157.5)	SRW	305 (12.0)	1219 (48.0)	1026 (40.4)	1707 (67.2)	1910 (75.2)	2586 (101.8)	1346 (53.0)	2586 (101.8)

SPECIAL APPLICATIONS – FULL SIZE K SERIES (4x4)

CMVSS135 and FMVSS135 Allowable Center of Gravity Charts

Model	GVWR kg (lb)	Brake System	Wheel- Base mm (in)	Rear Wheel	Incomplete, Pickup Box Removal, or Snow Plow Prep Package Vehicles							
					Coordinates of Allowable C/G Variation at CMVSS/FMVSS Unladen, Curb Weight + 181.4 kg (400 lb) mm (in)						Fwd C/G Limit mm (in)	RRwd C/G Limit mm (in)
					H ₁	H ₂	A	B	C	D	E	F
C10753	3084 (6800)	JF3 VSES	3644.9 (143.5)	SRW	305 (12.0)	1219 (48.0)	1092 (43.0)	1768 (69.6)	1834 (72.2)	2515 (99.0)	1219 (48.0)	2515 (99.0)
C10543	3084 (6800)	JF3 VSES	3644.9 (143.5)	SRW	305 (12.0)	1219 (48.0)	1092 (43.0)	1768 (69.6)	1834 (72.2)	2515 (99.0)	1219 (48.0)	2515 (99.0)
K10753	3175 (7000)	JF3 VSES	3644.9 (143.5)	SRW	305 (12.0)	1219 (48.0)	1067 (42.0)	1742 (68.6)	1834 (72.2)	2515 (99.0)	1219 (48.0)	2515 (99.0)
K10543	3175 (7000)	JF3 VSES	3644.9 (143.5)	SRW	305 (12.0)	1219 (48.0)	1067 (42.0)	1742 (68.6)	1834 (72.2)	2515 (99.0)	1219 (48.0)	2515 (99.0)
C10753	3084 (6800)	JD9	3644.9 (143.5)	SRW	305 (12.0)	1219 (48.0)	1265 (49.8)	1951 (76.8)	1864 (73.4)	2545 (100.2)	1265 (49.8)	2545 (100.2)
C10753	3175 (7000)	JD9	3644.9 (143.5)	SRW	305 (12.0)	1219 (48.0)	1265 (49.8)	1946 (76.6)	1864 (73.4)	2545 (100.2)	1265 (49.8)	2545 (100.2)
C10543	3084 (6800)	JD9	3644.9 (143.5)	SRW	305 (12.0)	1219 (48.0)	1265 (49.8)	1951 (76.8)	1864 (73.4)	2545 (100.2)	1265 (49.8)	2545 (100.2)
C10543	3220 (7100)	JD9	3644.9 (143.5)	SRW	305 (12.0)	1219 (48.0)	1270 (50.0)	1951 (76.8)	1864 (73.4)	2545 (100.2)	1270 (50.0)	2545 (100.2)
K10753	3175 (7000)	JD9	3644.9 (143.5)	SRW	305 (12.0)	1219 (48.0)	1265 (49.8)	1946 (76.6)	1864 (73.4)	2545 (100.2)	1265 (49.8)	2545 (100.2)
K10753	3266 (7200)	JD9	3644.9 (143.5)	SRW	305 (12.0)	1219 (48.0)	1290 (50.8)	1966 (77.4)	1864 (73.4)	2545 (100.2)	1290 (50.8)	2545 (100.2)
K10543	3311 (7300)	JD9	3644.9 (143.5)	SRW	305 (12.0)	1219 (48.0)	1275 (50.2)	19.1 (76.8)	1864 (73.4)	2545 (100.2)	1275 (50.2)	2545 (100.2)

ABS = Antilock Braking System
 Brake Systems: Vacuum Powered Boosters - JF3, JF7 and JD9.
 C/G = Center of Gravity
 DRW = Dual Rear Wheel
 SRW = Single Rear Wheel
 VSES = Vehicle Stability Enhancement System

CMVSS 135 and FMVSS 135 – LIGHT VEHICLE BRAKE SYSTEMS
Applies to all types of Incomplete Vehicles Contained in this Document
3500 kg (7,716 lb) GVWR or less

TYPE 2 The following statement is applicable to all types of Incomplete Vehicles contained in this document with a 3500 kg (7,716 lb) GVWR or less, (unless otherwise noted on the cover).

This incomplete vehicle when completed will conform to CMVSS 135 and FMVSS 135 provided it is completed in accordance with the following specific conditions by the (intermediate and) final stage manufacturer:

- A. Providing no alterations are made which affect the function, physical, chemical, or mechanical properties, environment, location or vital spatial clearances of the components, assemblies or systems, as manufactured by General Motors, including but not limited to those listed below (if equipped):

Anti-Lock Brake System	Hydraulic brake lines, fittings and routings
Brake assemblies and components (service/ parking) - (i.e. power boosters, master cylinder, wheel cylinder, calipers, rotors, wheel speed sensor, wheel speed sensor wiring, brake lining etc.)	Hydraulic brake valves and components
Brake pedal, brake switch, parking brake hand lever or park brake switch and related mechanical components	Master cylinder-warning statement
Brake system electrical controls and logic	Owner Manual instructions
Gauges and warning devices, and statements	Parking brake actuator and related mechanical components
Hydraulic brake fluid and reservoirs	Power steering or vacuum lines and routing
	Power steering or vacuum pump
	Tires and Wheels
	Vacuum brake lines, fittings and routings
	Vehicle wiring harnesses
	Wheelbases

- B. GVWR, GAWR front and rear weight ratings as listed on the Incomplete Vehicle Label affixed to the front cover of this document must not be exceeded.
- C. The center of gravity of the total vehicle falls within the areas referenced on the “ALLOWABLE CENTER OF GRAVITY CHART” that follows. Instructions for determining the allowable center of gravity variation are listed below:

These charts detail the envelope of allowable center of gravity variation for completed vehicles. This is significant for the lightly loaded portion of CMVSS 135 and FMVSS 135, which is defined as curb plus 181.4 kg (400 lb) distributed in the driver-passenger area of the vehicle.

The lightly loaded center of gravity of complete vehicles needs to be restricted so it will meet CMVSS 135 and FMVSS 135 stopping distances. The laden center of gravity does not need to be specified as it is controlled within the CMVSS 135 and FMVSS 135 test procedure by specific instructions as to how ballast is to be placed (while height is not controlled, it is assumed that for test purposes it would be reasonable).

CMVSS 135 and FMVSS 135 – LIGHT VEHICLE BRAKE SYSTEMS
Applies to all types of Incomplete Vehicles Contained in this Document
3500 kg (7,716 lb) GVWR or less

For Body Builder's use, the center of gravity location can be approximated by the following formula:

$$d = \frac{[Wrc + Wrb + [(Hp)(Wp)/WB]] WB}{Wt}$$

$$h = \frac{[h1Wc + h2Wb + (h3)(Wp)]}{Wt}$$

- d = horizontal distance from front wheels to completed vehicle center of gravity mm (in)
- h = vertical distance from ground to completed vehicle center of gravity mm (in)
- Wrc = rear component of Chassis weight kg (lb)
- Wrb = rear component of body weight kg (lb)
- WB = vehicle wheelbase mm (in)
- Wt = total weight of chassis and body kg (lb) plus 181.4 kg (400 lb)
- h1 = center of gravity height from ground of the Bare Chassis = 711 mm (28 in)
- Wc = total weight of Chassis kg (lb)
- h2 = center of gravity height of body from ground mm (in)
- Wb = total weight of body kg (lb)
- Wp = 181.4 kg (400 lb) Amount from lightly loaded definition that is evenly distributed in driver-passenger area of vehicle.
- Hp = 1467 mm (57.76 in) Horizontal distance from front axle to center of gravity of 181.4 kg (400 lb) evenly distributed in driver-passenger area of vehicle.
- h3 = 948 mm (37.32 in) Vertical center of gravity height of 181.4 kg (400 lb) evenly distributed in driver-passenger area for vehicles with 3500 kg (7,716 lb) GVWR or less.

CMVSS 135 and FMVSS 135 ALLOWABLE CENTER OF GRAVITY CHARTS

Model	GVWR kg (lb)	Brake System	Wheel- Base mm (in)	Rear Wheel	Incomplete, Pickup Box Removal, or Snow Plow Prep Package Vehicles							
					Coordinates of Allowable C/G Variation at CMVSS/FMVSS Unladen, Curb Weight + 181.4 kg (400 lb) mm (in)						Fwd C/G Limit mm (in)	RRwd C/G Limit mm (in)
					H ₁	H ₂	A	B	C	D	E	F
C10703	2903 (6400)	JF7	3022.6 (119.0)	SRW	305 (12.0)	1219 (48.0)	1020 (40.2)	1280 (50.4)	1690 (66.5)	2289 (90.1)	1020 (40.2)	2289 (90.1)
C10903	2903 (6400)	JF7	3378.2 (133.0)	SRW	305 (12.0)	1219 (48.0)	1130 (44.5)	1385 (54.5)	1967 (77.4)	2507 (59.3)	1130 (44.5)	2507 (59.3)
C10753	2903 (6400)	JF7	3644.9 (143.5)	SRW	305 (12.0)	1219 (48.0)	1213 (47.7)	1467 (57.8)	2109 (83.0)	2648 (104.2)	1213 (47.7)	2648 (104.2)
K10703	2903 (6400)	JF7	3022.6 (119.0)	SRW	305 (12.0)	1219 (48.0)	1020 (40.2)	1280 (50.4)	1690 (66.5)	2289 (90.1)	1020 (40.2)	2289 (90.1)
K10903	2903 (6400)	JF7	3378.2 (133.0)	SRW	305 (12.0)	1219 (48.0)	1130 (44.5)	1385 (54.5)	1967 (77.4)	2507 (59.3)	1130 (44.5)	2507 (59.3)
C10703	3084 (6800)	JF3	3022.6 (119.0)	SRW	305 (12.0)	1219 (48.0)	1020 (40.2)	1449 (57.0)	1905 (75.0)	2427 (95.5)	1119 (44.0)	2372 (93.4)
C10903	3175 (7000)	JF3	3378.2 (133.0)	SRW	305 (12.0)	1219 (48.0)	1130 (44.5)	1536 (60.5)	2106 (82.9)	2646 (104.2)	1250 (49.2)	2646 (104.2)
C10543	3084 (6800)	JF3	3644.9 (143.5)	SRW	305 (12.0)	1219 (48.0)	1213 (47.8)	1736 (68.3)	2393 (94.2)	2933 (115.5)	1277 (50.3)	2738 (107.8)
C10753	3084 (6800)	JF3	3644.9 (143.5)	SRW	305 (12.0)	1219 (48.0)	1213 (47.8)	1736 (68.3)	2393 (94.2)	2933 (115.5)	1277 (50.3)	2738 (107.8)
C10953	3130 (6900)	JF3	4000.5 (157.5)	SRW	305 (12.0)	1219 (48.0)	1323 (52.1)	1835 (72.2)	2387 (94.0)	3064 (120.6)	1323 (52.1)	3005 (118.3)
K10903	3084 (6800)	JF3	3378.2 (133.0)	SRW	305 (12.0)	1219 (48.0)	1130 (44.5)	1661 (65.4)	2076 (81.7)	2753 (108.4)	1181 (46.5)	2538 (99.9)
K10543	3175 (7000)	JF3	3644.9 (143.5)	SRW	305 (12.0)	1219 (48.0)	1213 (47.8)	1760 (69.3)	2169 (85.4)	2846 (112.0)	1261 (49.6)	2738 (107.8)
K10753	3175 (7000)	JF3	3644.9 (143.5)	SRW	305 (12.0)	1219 (48.0)	1213 (47.8)	1760 (69.3)	2169 (85.4)	2846 (112.0)	1261 (49.6)	2738 (107.8)

CMVSS 135 and FMVSS 135 ALLOWABLE CENTER OF GRAVITY CHARTS

Model	GVWR kg (lb)	Brake System	Wheel- Base mm (in)	Rear Wheel	Incomplete, Pickup Box Removal, or Snow Plow Prep Package Vehicles							
					Coordinates of Allowable C/G Variation at CMVSS/FMVSS Unladen, Curb Weight + 181.4 kg (400 lb) mm (in)						Fwd C/G Limit mm (in)	RRwd C/G Limit mm (in)
					H ₁	H ₂	A	B	C	D	E	F
K10953	3175 (7000)	JF3	4000.5 (157.5)	SRW	305 (12.0)	1219 (48.0)	1323 (52.1)	1844 (72.6)	2358 (92.8)	3035 (119.5)	1383 (54.4)	3004 (118.3)
C10543	3084 (6800)	JD9	3644.9 (143.5)	SRW	305 (12.0)	1219 (48.0)	1213 (47.8)	1507 (59.3)	1879 (74.0)	2556 (100.6)	1213 (47.8)	2556 (100.6)
C10543	3220 (7100)	JD9	3644.9 (143.5)	SRW	305 (12.0)	1219 (48.0)	1213 (47.8)	1507 (59.3)	1814 (71.4)	2491 (98.1)	1213 (47.8)	2491 (98.1)
C10753	3084 (6800)	JD9	3644.9 (143.5)	SRW	305 (12.0)	1219 (48.0)	1213 (47.8)	1507 (59.3)	1879 (74.0)	2556 (100.6)	1213 (47.8)	2556 (100.6)
C10753	3175 (7000)	JD9	3644.9 (143.5)	SRW	305 (12.0)	1219 (48.0)	1213 (47.8)	1507 (59.3)	1835 (72.2)	2512 (98.9)	1213 (47.8)	2512 (98.9)
K10543	3175 (7000)	JD9	3644.9 (143.5)	SRW	305 (12.0)	1219 (48.0)	1213 (47.8)	1507 (59.3)	1835 (72.2)	2512 (98.9)	1213 (47.8)	2512 (98.9)
K10543	3311 (7300)	JD9	3644.9 (143.5)	SRW	305 (12.0)	1219 (48.0)	1213 (47.8)	1524 (60.0)	1774 (69.8)	2450 (96.4)	1213 (47.8)	2450 (96.4)
K10753	3175 (7000)	JD9	3644.9 (143.5)	SRW	305 (12.0)	1219 (48.0)	1213 (47.8)	1507 (59.3)	1835 (72.2)	2512 (98.9)	1213 (47.8)	2512 (98.9)
K10753	3266 (7200)	JD9	3644.9 (143.5)	SRW	305 (12.0)	1219 (48.0)	1213 (47.8)	1507 (59.3)	1794 (70.6)	2470 (97.2)	1213 (47.8)	2470 (97.2)

ABS = Antilock Braking System
 Brake Systems: Vacuum Powered Boosters - JF3, JF7 and JD9.
 C/G = Center of Gravity
 DRW = Dual Rear Wheel
 SRW = Single Rear Wheel
 VSES = Vehicle Stability Enhancement System

CMVSS 135 and FMVSS 135 ALLOWABLE CENTER OF GRAVITY CHARTS

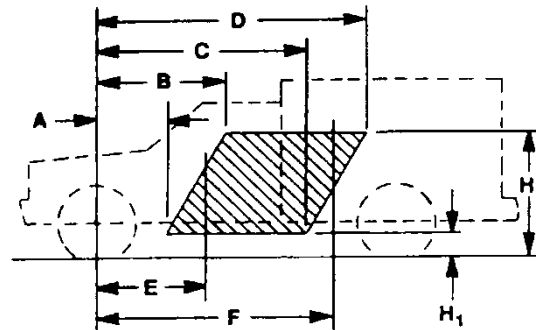

C/G of vehicle in CMVSS or FMVSS unladen condition [Curb + 181.4 kg. (400 lb)] must be inside shaded area – that is, the C/G must be within the trapezoid formed by the coordinates A, B, C, D, H1, & H2, plus the C/G must be to the rear of vertical line E and forward of vertical line F.

CMVSS 301 and FMVSS 301 – FUEL SYSTEM INTEGRITY
Refer to Vehicle Types, GVWRs, and Applicable Statements that follow

TYPE 2 The following statement is applicable to all types of incomplete vehicles contained in this document 4536 kg (10,000 lb) GVWR or less with any Incomplete Option (unless otherwise noted on the cover).

This incomplete vehicle, when completed, will conform to CMVSS 301 and FMVSS 301 providing it is completed in accordance with the following specific conditions by the (intermediate and) final stage manufacturer:

A. The following items when installed by General Motors will conform providing no alterations are made which affect the function, physical, chemical, or mechanical properties, environment, location or vital spatial clearances of the components, assemblies or systems, as manufactured by General Motors, including but not limited to those listed below:

- | | |
|---|--|
| Fuel filler door assembly | Fuel tank filler neck/pipe assembly |
| Fuel filter | Fuel tank filler neck/pipe fasteners |
| Fuel hose shields | Fuel tank filler neck/pipe hose clamp/clamp assembly |
| Fuel pipes and hose assemblies | Fuel tank filler neck/pipe housing assembly |
| Fuel system | Fuel tank filler neck/pipe plate |
| Fuel system attaching or protective structure | Fuel tank filler neck/pipe vent hose |
| Fuel system control module | Fuel tank filler neck/pipe vent hose clamp/strap |
| Fuel system fasteners and retainers | Fuel tank meter assembly |
| Fuel tank assembly | Fuel tank shields |
| Fuel tank cap assembly | Fuel vapor lines and canister assembly |
| Fuel tank filler neck hose | |

B. The (intermediate and) final stage manufacturer conforms to the following:

1. a box, platform, or other rear structural assembly must be installed on the back of the vehicle.
2. the rear assembly structure must provide comparable stiffness to the pickup box sold as original equipment as part of the complete vehicle version of this product.
3. the method of rear assembly structure mounting and mount properties (material and structural) are similar to the those used to attach the pickup box sold as original equipment as part of the complete vehicle version of this product.
4. The dimension and mass as well as other restrictions (excluding the Maximum Frontal Area) found in MVSS 301 Table A, are not exceeded.

CMVSS 301 and FMVSS 301 – FUEL SYSTEM INTEGRITY
Refer to Vehicle Types, GVWRs, and Applicable Statements that follow

- C. This incomplete vehicle, when completed, will conform to CMVSS 301 and FMVSS 301 Fuel System Integrity if:
1. No alterations are made to the fuel system and attaching or protective structure, the contents or arrangement of the engine compartment, the powertrain and driveline, the cab structure, the chassis structure, the bumper system, door structure, or tires and wheels.
 2. The dimension and mass as well as other restrictions (excluding the Maximum Frontal Area) found in MVSS 301 Table A, are not exceeded.
 3. The final stage manufacturer completes the fuel filler neck and fuel level sender installation(s) according to “Best Practices” or “Special Applications (if applicable)” sections within the **Body Builders Manual on the www.gmupfitter.com website**. **If there are additional questions, contact the Upfitter Integration Hotline at 1-800-875-4742.**
 4. During all barrier impact tests:
 - a. No component installed by any intermediate or final stage manufacturer impinges or causes distortion to the fuel system with sufficient energy to puncture or separate the fuel system.
 - b. No vehicle modification by any intermediate or final stage manufacturer results in any portion of the vehicle impinging upon or causing distortion to the fuel system with sufficient energy to puncture or separate the fuel system. Care should be taken that the structural integrity of the vehicle is restored following any modification of the structure.
 - c. Any body installed by an intermediate or final stage manufacturer is mounted securely to absorb loads and prevent movement relative to the frame which could cause any fuel system component to be punctured, separated or otherwise damaged when tested to applicable procedures of CMVSS 301 or FMVSS 301.

SPECIAL APPLICATIONS – FULL SIZE K SERIES (4x4)

CMVSS 301 and FMVSS 301 – FUEL SYSTEM INTEGRITY
Refer to Vehicle Types, GVWRs, and Applicable Statements that follow

TABLE A

Models	GVWR kg (lb) (RPO)	Engine (RPO)	General Body Types	Maximum Body Center of Gravity Height cm (in)	Maximum Body Height cm (in)	Maximum Unloaded Vehicle Weight (Completed Vehicle Maximum Weight) kg (lb)	Maximum Body Weight kg (lb)	Maximum Frontal Area m ² (ft ²)
C20903 Reg. Cab	4,218 (9,300) (G4A)	6.0 L Gas (L96)	Low Service	35.6 (14.0) above the frame	Under 157.5 (62.0)	3,901 (8,600)	771 (1,700)	Not Applicable
C20903 Reg. Cab	4,218 (9,300) (G4A)	6.0 L Gas (L96)	High Service	51.6 (20.3) above the frame	157.5 (62.0) and over	3,901 (8,600)	816 (1,800)	Not Applicable
C20903 Reg. Cab	4,491 (9,900) (C4M)	6.6 L Diesel (LGH)	Low Service	35.6 (14.0) above the frame	Under 157.5 (62.0)	3,992 (8,800)	771 (1,700)	Not Applicable
C20903 Reg. Cab	4,491 (9,900) (C4M)	6.6 L Diesel (LGH)	High Service	51.6 (20.3) above the frame	157.5 (62.0) and over	3,992 (8,800)	1,179 (2,600)	Not Applicable
C20903 Reg. Cab	4,536 (10,000) (C7A)	6.0 L Gas (L96)	Low Service	35.6 (14.0) above the frame	Under 157.5 (62.0)	3,992 (8,800)	771 (1,700)	Not Applicable
C20903 Reg. Cab	4,536 (10,000) (C7A)	6.0 L Gas (L96)	High Service	51.6 (20.3) above the frame	157.5 (62.0) and over	4,218 (9,300)	1,179 (2,600)	Not Applicable
C20943 Crew Cab	4,309 (9,500) (GEH)	6.0 L Gas (L96)	Low Service	35.6 (14.0) above the frame	Under 157.5 (62.0)	3,992 (8,800)	771 (1,700)	Not Applicable

SPECIAL APPLICATIONS – FULL SIZE K SERIES (4x4)

CMVSS 301 and FMVSS 301 – FUEL SYSTEM INTEGRITY
Refer to Vehicle Types, GVWRs, and Applicable Statements that follow

TABLE A

Models	GVWR kg (lb) (RPO)	Engine (RPO)	General Body Types	Maximum Body Center of Gravity Height cm (in)	Maximum Body Height cm (in)	Maximum Unloaded Vehicle Weight (Completed Vehicle Maximum Weight) kg (lb)	Maximum Body Weight kg (lb)	Maximum Frontal Area m ² (ft ²)
C20943 Crew Cab	4,309 (9,500) (GEH)	6.0 L Gas (L96)	High Service	51.6 (20.3) above the frame	157.5 (62.0) and over	3,992 (8,800)	816 (1,800)	Not Applicable
C20943 Crew Cab	4,536 (10,000) (C7A)	6.6 L Diesel (LGH)	Low Service	35.6 (14.0) above the frame	Under 157.5 (62.0)	3,992 (8,800)	771 (1,700)	Not Applicable
C20943 Crew Cab	4,536 (10,000) (C7A)	6.6 L Diesel (LGH)	High Service	51.6 (20.3) above the frame	157.5 (62.0) and over	4,218 (9,300)	1,179 (2,600)	Not Applicable
C20953 Ext. Cab	4,309 (9,500) (GEH)	6.0 L Gas (L96)	Low Service	35.6 (14.0) above the frame	Under 157.5 (62.0)	3,992 (8,800)	771 (1,700)	Not Applicable
C20953 Ext. Cab	4,309 (9,500) (GEH)	6.0 L Gas (L96)	High Service	51.6 (20.3) above the frame	157.5 (62.0) and over	3,992 (8,800)	816 (1,800)	Not Applicable
C20953 Ext. Cab	4,536 (10,000) (C7A)	6.6 L Diesel (LGH)	Low Service	35.6 (14.0) above the frame	Under 157.5 (62.0)	3,992 (8,800)	771 (1,700)	Not Applicable
C20953 Ext. Cab	4,536 (10,000) (C7A)	6.6 L Diesel (LGH)	High Service	51.6 (20.3) above the frame	157.5 (62.0) and over	4,218 (9,300)	1,179 (2,600)	Not Applicable

CMVSS 301 and FMVSS 301 – FUEL SYSTEM INTEGRITY
Refer to Vehicle Types, GVWRs, and Applicable Statements that follow

TABLE A

Models	GVWR kg (lb) (RPO)	Engine (RPO)	General Body Types	Maximum Body Center of Gravity Height cm (in)	Maximum Body Height cm (in)	Maximum Unloaded Vehicle Weight (Completed Vehicle Maximum Weight) kg (lb)	Maximum Body Weight kg (lb)	Maximum Frontal Area m ² (ft ²)
K20903 Reg. Cab	4,309 (9,500) (GEH)	6.0 L Gas (L96)	Low Service	35.6 (14.0) above the frame	Under 157.5 (62.0)	3,901 (8,600)	771 (1,700)	Not Applicable
K20903 Reg. Cab	4,309 (9,500) (GEH)	6.0 L Gas (L96)	High Service	51.6 (20.3) above the frame	157.5 (62.0) and over	3,901 (8,600)	816 (1,800)	Not Applicable
K20903 Reg. Cab	4,491 (9,900) (C4M)	6.6 L Diesel (LGH)	Low Service	35.6 (14.0) above the frame	Under 157.5 (62.0)	3,992 (8,800)	771 (1,700)	Not Applicable
K20903 Reg. Cab	4,491 (9,900) (C4M)	6.6 L Diesel (LGH)	High Service	51.6 (20.3) above the frame	157.5 (62.0) and over	3,992 (8,800)	1,179 (2,600)	Not Applicable
K20943 Crew Cab	4,491 (9,900) (C4M)	6.0 L Gas (L96)	Low Service	35.6 (14.0) above the frame	Under 157.5 (62.0)	3,992 (8,800)	771 (1,700)	Not Applicable
K20943 Crew Cab	4,491 (9,900) (C4M)	6.0 L Gas (L96)	High Service	51.6 (20.3) above the frame	157.5 (62.0) and over	3,992 (8,800)	816 (1,800)	Not Applicable
K20943 Crew Cab	4,536 (10,000) (C7A)	6.6 L Diesel (LGH)	Low Service	35.6 (14.0) above the frame	Under 157.5 (62.0)	3,992 (8,800)	771 (1,700)	Not Applicable

SPECIAL APPLICATIONS – FULL SIZE K SERIES (4x4)

CMVSS 301 and FMVSS 301 – FUEL SYSTEM INTEGRITY
Refer to Vehicle Types, GVWRs, and Applicable Statements that follow

TABLE A

Models	GVWR kg (lb) (RPO)	Engine (RPO)	General Body Types	Maximum Body Center of Gravity Height cm (in)	Maximum Body Height cm (in)	Maximum Unloaded Vehicle Weight (Completed Vehicle Maximum Weight) kg (lb)	Maximum Body Weight kg (lb)	Maximum Frontal Area m ² (ft ²)
K20943 Crew Cab	4,536 (10,000) (C7A)	6.6 L Diesel (LGH)	High Service	51.6 (20.3) above the frame	157.5 (62.0) and over	4,218 (9,300)	1,179 (2,600)	Not Applicable
K20953 Ext. Cab	4,309 (9,500) (GEH)	6.0 L Gas (L96)	Low Service	35.6 (14.0) above the frame	Under 157.5 (62.0)	3,992 (8,800)	771 (1,700)	Not Applicable
K20953 Ext. Cab	4,309 (9,500) (GEH)	6.0 L Gas (L96)	High Service	51.6 (20.3) above the frame	157.5 (62.0) and over	3,992 (8,800)	816 (1,800)	Not Applicable
K20953 Ext. Cab	4,536 (10,000) (C7A)	6.6 L Diesel (LGH)	Low Service	35.6 (14.0) above the frame	Under 157.5 (62.0)	3,992 (8,800)	771 (1,700)	Not Applicable
K20953 Ext. Cab	4,536 (10,000) (C7A)	6.6 L Diesel (LGH)	High Service	51.6 (20.3) above the frame	157.5 (62.0) and over	4,218 (9,300)	1,179 (2,600)	Not Applicable
C30943 Crew Cab	4,536 (10,000) (C7A)	6.0 L Gas (L96)	Low Service	35.6 (14.0) above the frame	Under 157.5 (62.0)	3,992 (8,800)	771 (1,700)	Not Applicable
C30943 Crew Cab	4,536 (10,000) (C7A)	6.0 L Gas (L96)	High Service	51.6 (20.3) above the frame	157.5 (62.0) and over	4,218 (9,300)	1,179 (2,600)	Not Applicable

SPECIAL APPLICATIONS – FULL SIZE K SERIES (4x4)

CMVSS 301 and FMVSS 301 – FUEL SYSTEM INTEGRITY
Refer to Vehicle Types, GVWRs, and Applicable Statements that follow

TABLE A

Models	GVWR kg (lb) (RPO)	Engine (RPO)	General Body Types	Maximum Body Center of Gravity Height cm (in)	Maximum Body Height cm (in)	Maximum Unloaded Vehicle Weight (Completed Vehicle Maximum Weight) kg (lb)	Maximum Body Weight kg (lb)	Maximum Frontal Area m ² (ft ²)
C30953 Ext. Cab	4,536 (10,000) (C7A)	6.0 L Gas (L96)	Low Service	35.6 (14.0) above the frame	Under 157.5 (62.0)	3,992 (8,800)	771 (1,700)	Not Applicable
C30953 Ext. Cab	4,536 (10,000) (C7A)	6.0 L Gas (L96)	High Service	51.6 (20.3) above the frame	157.5 (62.0) and over	4,218 (9,300)	1,179 (2,600)	Not Applicable
K30903 Reg. Cab	4,536 (10,000) (C7A)	6.0 L Gas (L96)	Low Service	35.6 (14.0) above the frame	Under 157.5 (62.0)	3,992 (8,800)	771 (1,700)	Not Applicable
K30903 Reg. Cab	4,536 (10,000) (C7A)	6.0 L Gas (L96)	High Service	51.6 (20.3) above the frame	157.5 (62.0) and over	4,218 (9,300)	1,179 (2,600)	Not Applicable
K30953 Ext. Cab	4,536 (10,000) (C7A)	6.0 L Gas (L96)	Low Service	35.6 (14.0) above the frame	Under 157.5 (62.0)	3,992 (8,800)	771 (1,700)	Not Applicable
K30953 Ext. Cab	4,536 (10,000) (C7A)	6.0 L Gas (L96)	High Service	51.6 (20.3) above the frame	157.5 (62.0) and over	4,218 (9,300)	1,179 (2,600)	Not Applicable

Notes:

- **Table A above applies to ONLY incomplete vehicles (RPO: &VXT) as manufactured by GM without pick-up boxes (RPO: &ZW9).**

CMVSS 301 and FMVSS 301 – FUEL SYSTEM INTEGRITY **Refer to Vehicle Types, GVWRs, and Applicable Statements that follow**

Notes:

- On page 2 within this document, before each vehicle illustration and after the word TYPE, is a list of types of vehicles into which the incomplete vehicle is designed to be manufactured. For the allowable vehicle TYPE(s), CMVSS 301 and FMVSS 301 only applies to vehicles with a 4536 kg (10,000 lb) GVWR or less. As a result, Table A does not include data for GVWRs exceeding 4536 kg (10,000 lb) GVWR.
- For all included models, the maximum cab to body clearance is 7.6 cm (3.0 in)
- CA (back of cab sheet metal to centerline of rear axle dimensions) are located within the Body Builder website, “General Arrangement” section, at www.gmupfitter.com or contact the Upfitter Integration Hotline at 1-800-875-4742.
- * The Maximum Frontal Area column applies to: PART II, U.S. EPA, CALIFORNIA, AND CANADIAN EXHAUST & EVAPORATIVE EMISSION REQUIREMENTS AND EPA FUEL ECONOMY REGULATIONS.
- The completed vehicle Maximum Unloaded Vehicle (Curb) Weight, and/or GVWR, should not be exceeded. If any of these restrictions are exceeded, re-certification by the final stage manufacturer will be required.
- The Maximum Body Weight equals the Maximum Unloaded Vehicle (curb) Weight minus the incomplete Cab & Chassis (curb) weight as manufactured by GM. The actual vehicle (curb) weight must be determined by weighing the vehicle with fuel and fluids filled, minus occupants and cargo. The Maximum Body Weight in Table A is based on the maximum possible incomplete Cab & Chassis (curb) weight as manufactured by GM. It may be permissible to exceed the Maximum Body Weight (as stated in Table A), provided the Maximum Unloaded Vehicle (curb) Weight (as stated in Table A) is not exceeded at final stage manufacturer completion.
- Also see the Vehicle Emission Control Information Label in the vehicle engine compartment for maximum completed vehicle curb weight, GVWR, and frontal area restrictions, if applicable.
- Note: WB refers to wheelbase; GVWR refers to Gross Vehicle Weight Rating.

'K' Series Snow Plow Best Practices

- 1) OEM Steering gear, Suspension and Powertrain Component mounting holes & associated OEM fasteners should not be used to attach Snow Plow Mounting equipment.
- 2) A suggested allowance of 10 mm minimum clearance to stationary OEM components example: Bumper Asm, Steering Box, Cooling System components is highly recommended. Note these components have varying positional tolerances.
- 3) A suggested allowance of 20 mm minimum clearance to OEM components subject to movement example: Steering Gear, Suspension (A-Arm, Axle, Strut, & Stab Bar asms) at full jounce is highly recommended. Note these components have varying positional tolerances.
- 4) Snow Plow & Associated Mounting Equipment should not exceed front axle available payload rating of vehicle as optioned. Plow Blade height, width & mass should be in accordance with Snow Plow Manufacturers recommended requirements for specific vehicle.

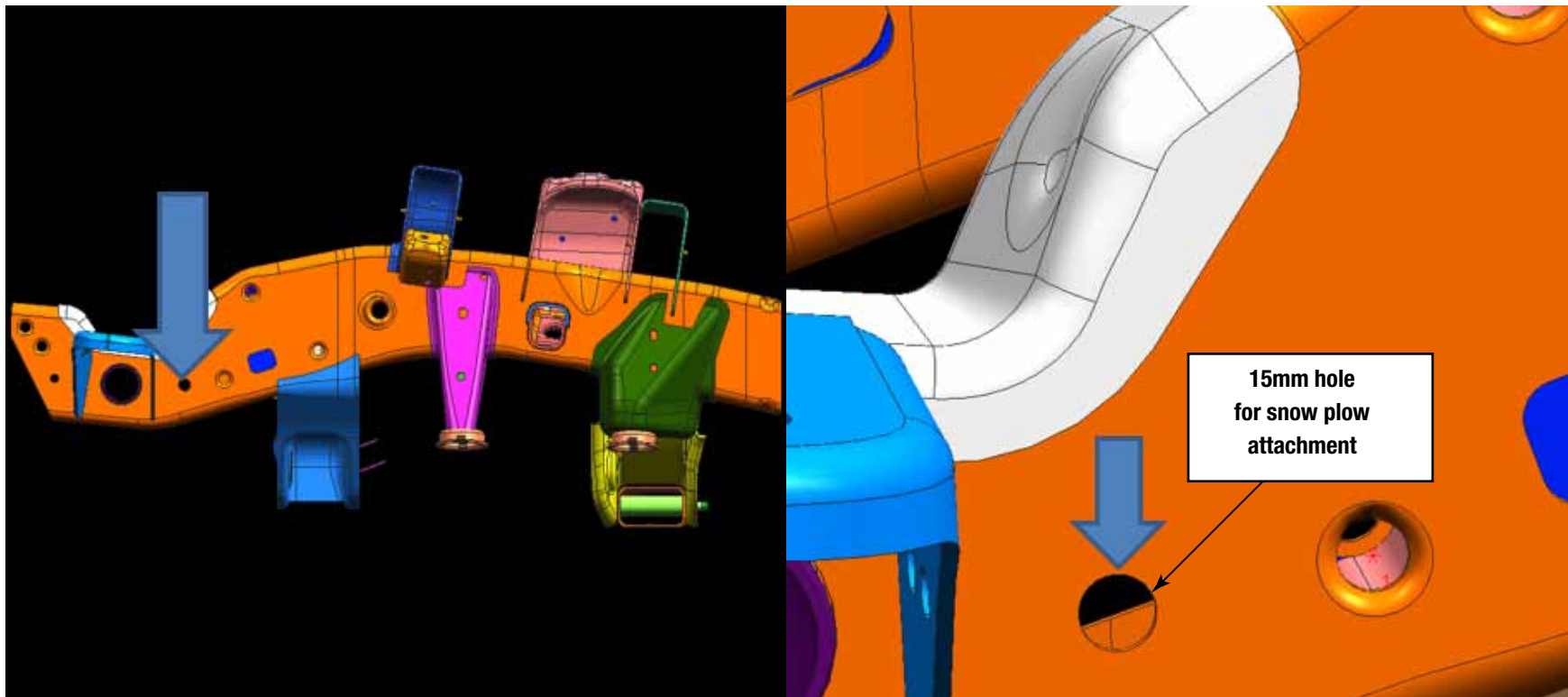

SPECIAL APPLICATIONS – FULL SIZE K SERIES (4x4)

'K' Series Snow Plow Applications – Max. Plow/Hardware Weights

Body	Engine RPO	Eng type	20	30 SRW	30 DRW
			FGAWR with VYU		
903	L96	Gas	5200	5600	5600
	LML	Diesel	6000	6000	6000
753	L96	Gas	5200	-	-
	LML	Diesel	6000	-	-
953	L96	Gas	5600	5600	5600
	LML	Diesel	6000	6000	6000
743	L96	Gas	5200	5600	-
	LML	Diesel	6000	6000	-
943	L96	Gas	5600	5600	5600
	LML	Diesel	6000	6000	6000

Body	Engine RPO	Eng type	20	30 SRW	30 DRW
903	L96	Gas	100/925	100/1000	100/1000
	LML	Diesel	100/1000	100/975	100/875
753	L96	Gas	100/875	-	-
	LML	Diesel	100/925	-	-
953	L96	Gas	100/1000	100/1000	100/950
	LML	Diesel	100/875	100/825	100/725
743	L96	Gas	100/850	100/1000	-
	LML	Diesel	100/1000	100/875	-
943	L96	Gas	100/1000	100/1000	100/925
	LML	Diesel	100/825	100/775	100/700

Notes 100/xxx = 100Lbs maximum of permanently attached snow plow mounting hardware / xxx Lbs. maximum of removable snow plow blade and blade hardware. Unused hardware weight can be applied to Plow.

Maximum plow weights based on a vehicle with average manufacturer option content and 150Lbs each for driver and one additional front seat occupant. Additional equipment and occupants can reduce maximum plow weight.

Rear compensating weight may be required to maintain front axle weight below 65% of total vehicle weight when equipped with snow plow, consult your snow plow manufacturer for specific compensating weight recommendation

VYU is offered on incomplete vehicles please consult Upfitter for recommended maximum plow weights