

General Motors Upfitter Integration



OWNER'S MANUAL SUPPLEMENT

AIRBAG DEPLOYMENT ZONES

FOR 2018

FULL SIZE VANS

(CHEVROLET EXPRESS/GMC SAVANA)

General Motors Upfitter Integration



Note to User:

As part of our mission to provide an up-to-date website that includes detailed Body Builder Manuals, Technical Bulletins, and Best Practice Manuals, we are now using sectional excerpts directly from the General Motors Service Information publications for our Electrical Body Builder Manuals.

You will note that the section numbers are non-sequential as we have provided only those that are believed to be the most pertinent to the Upfitter community and best suited to their needs*.

This new usage of the Service Information provides the opportunity for us to remain consistent with the changes that take place throughout the model year and to provide you updated information in a timelier fashion.

**** If you would like to have access to all of the electrical Service Information, please apply for a subscription from ACDelco at***

http://acdelcotechconnect.com/html/tss_tech_esi.jsp

Contents

Introduction	2
Seats and Restraints	3
Index	11

Introduction



The names, logos, emblems, slogans, vehicle model names, and vehicle body designs appearing in this supplement including, but not limited to, GM, the GM logo, CHEVROLET, the CHEVROLET Emblem, GMC, the GMC Truck Emblem, SAVANA, and EXPRESS are trademarks and/or service marks of General Motors LLC, its subsidiaries, affiliates, or licensors.

For vehicles first sold in Canada, substitute the name "General Motors of Canada Company" for Chevrolet or GMC Motor Division wherever it appears in this manual.

Keep this manual in the vehicle for quick reference.

Canadian Vehicle Owners

A French language manual can be obtained from your dealer, at www.helminc.com, or from:

Propriétaires Canadiens

On peut obtenir un exemplaire de ce guide en français auprès du concessionnaire ou à l'adresse suivante:

Helm, Incorporated
Attention: Customer Service
47911 Halyard Drive
Plymouth, MI 48170
USA

Using this Supplement

This supplement contains information specific to the unique components of the vehicle. It does not explain everything you need to know about the vehicle. Read this supplement along with the owner's manual to learn about the vehicle's features and controls.

Seats and Restraints

Airbag System

Questions and Answers About
 Airbags and Specialty Law
 Enforcement Vehicles 3
 Customer-Installed
 Equipment 4
 Airbag Deployment Diagrams ... 6

Airbag System

Questions and Answers About Airbags and Specialty Law Enforcement Vehicles

Q: Can equipment such as radar devices, video cameras, and radio trees be mounted in a specialty vehicle equipped with a right front passenger frontal airbag?

A: Yes, but care must be taken to properly mount the equipment outside of the airbag “deployment zone.”

Q: What is the airbag “deployment zone”?

A: The term “deployment zone” describes the space an airbag takes up when fully inflated. Airbags need room to work properly, and anything in the “deployment zone” — such as improperly mounted equipment — can greatly affect the performance of the airbag.

 **Warning**

Airbags inflate with great force, faster than the blink of an eye. No objects, such as shotguns, should be placed over or near the airbag covers. Equipment mounted too close to an inflating airbag could prevent the airbag from operating properly to protect the occupants or could be forced into an occupant or break and become a dangerous projectile, causing severe injury or even death. To help prevent injury and to allow the airbag to perform as it was designed, do not mount equipment inside the airbag deployment zones.

Q: How can I identify the airbag “deployment zone” in my vehicle?

A: See *Airbag Deployment Diagrams* ⇨ 6 for more information. The diagrams provide the approximate dimensions of the “deployment

4 Seats and Restraints

zones” for your specialty vehicle. Before doing any service work, including the installation of any equipment, consult the appropriate service manual.

Q: Is it possible to shield equipment so it does not interfere with airbag deployment?

A: While shielding may protect certain equipment from being damaged or dislodged, it may also negatively affect how an airbag inflates. Therefore, we cannot recommend the placement of any equipment in the deployment zone, even when shielding.

Q: Can the installation of push bumpers on the front end of the vehicle affect the deployment of the airbag?

A: It is not likely that installing push bumpers will affect sensing for the airbag as long as the vehicle structure itself is not modified. GM is not aware of any adverse effects from the many push

bumpers that have been installed on current model GM police vehicles with airbags.

See “Adding Equipment to the Airbag-Equipped Vehicle” in the owner’s manual for more information.

Customer-Installed Equipment

Before installing equipment, read the following.

Warning

Do not install equipment in the inflation path of any airbag. The equipment may interfere with the deployment of the airbag, may damage the airbag, or otherwise be damaged or forced into an occupant, all of which may cause severe injury or even death.

(Continued)

Warning (Continued)

Do not attach anything to the steering wheel hub or mount any equipment within the deployment zone for the driver airbag.

Do not mount equipment on the passenger side of the instrument panel top pad deployment zone. Equipment should not be mounted on or around the passenger airbag opening because of a deploying airbag. To allow the airbag to perform as it was designed, do not mount equipment inside the airbag deployment zone.

Do not use seat accessories that block the inflation path of the driver or passenger seat-mounted side impact airbag or install equipment in the seat-mounted side impact airbag deployment zones.

(Continued)

Warning (Continued)

Do not mount a security barrier such that the ends of the barrier or brackets are within the roof-rail airbag deployment zones.

Avoid installing wiring for roof-rail emergency lighting or radio antennas that may restrict the proper deployment of the roof-rail airbags.

Do not use seat accessories, console accessories, or other accessories that block the inflation path of the driver seat front center airbag (if equipped).

Do not remove the front center console to install a police package center console, or otherwise install equipment or mount equipment between or just behind the front bucket seats on vehicles equipped with the driver seat front center airbag.

Caution

GM approved service procedures must be followed to remove and reinstall the instrument panel to the pad to ensure proper airbag deployment.

6 Seats and Restraints

Airbag Deployment Diagrams

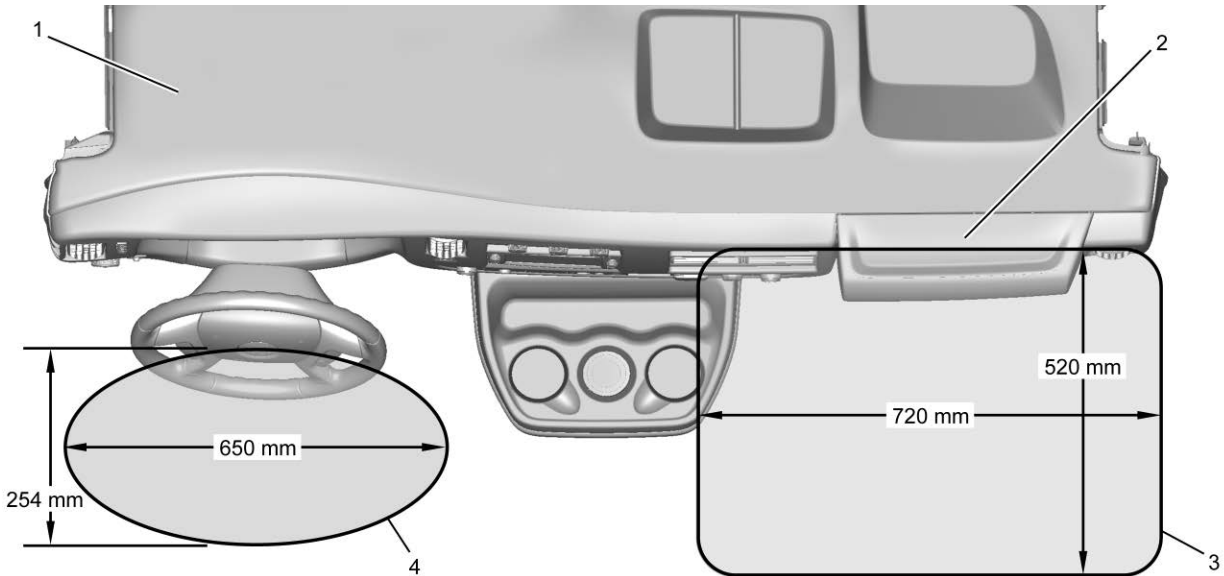

Top View of Instrument Panel and Approximate Deployment Area of the Airbag Zone

1. Instrument Panel
2. Passenger Side Airbag
Deployment Door
3. Passenger Side Airbag
Deployment Zone
4. Driver Side Airbag
Deployment Zone

See *Customer-Installed Equipment*

⇨ 4.

8 Seats and Restraints

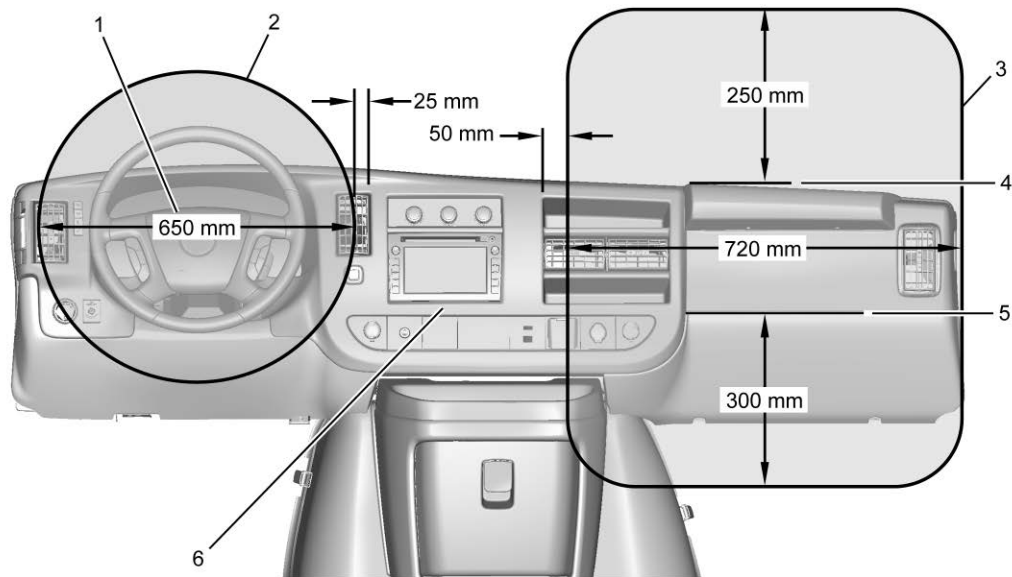

Rear View of the Instrument Panel and Approximate Deployment Area of the Airbag Zone

1. Diameter of Driver Side Airbag
2. Driver Side Airbag Deployment Zone
3. Passenger Side Airbag Deployment Zone
4. Top of Instrument Panel

5. Bottom of Passenger Side Airbag Door
 6. Instrument Panel
- See *Customer-Installed Equipment*
⇨ 4.

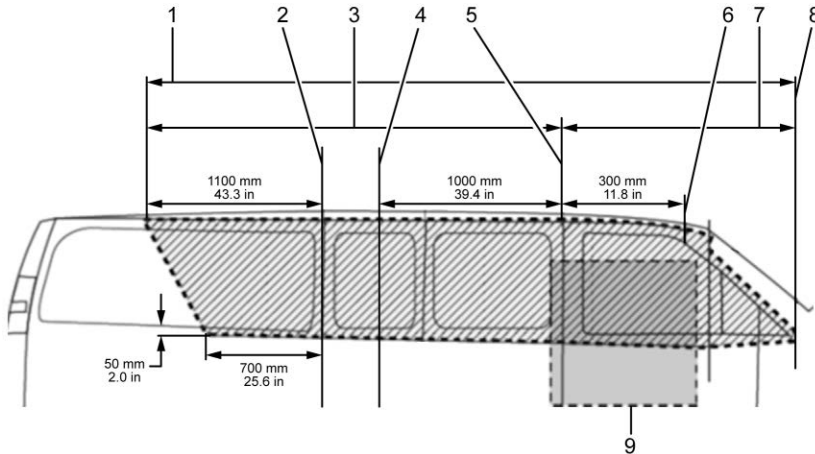

Roof-Rail and Seat-Mounted Side Impact Airbag Deployment Zones – Passenger Side Shown, Driver Side Similar (Passenger Van)

- | | |
|--|---|
| <ul style="list-style-type: none"> 1. Zone A 2. Back of C-Pillar 3. Zone C 4. Zones A and C Roof-rail Inflator Location 5. Back of B-Pillar | <ul style="list-style-type: none"> 6. Zone B Roof-rail Inflator Location 7. Zone B 8. Front of Door Mirror Patch 9. Seatback Thorax Airbag Zone <p>See <i>Customer-Installed Equipment</i>
⇨ 4.</p> |
|--|---|

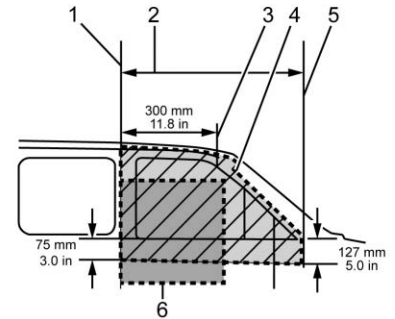

Roof-Rail Side Impact Airbag Deployment Zones – Passenger Side Shown, Driver Side Similar (Cargo Van and Cutaway Models)

- 1. Back of B-Pillar
 - 2. Zone B
 - 3. Zone B Roof-rail Inflator Location
 - 4. Upper Corner of Windshield
 - 5. Front of Door Mirror Patch
 - 6. Seatback Thorax Airbag Zone
- See *Customer-Installed Equipment*
⇨ 4.

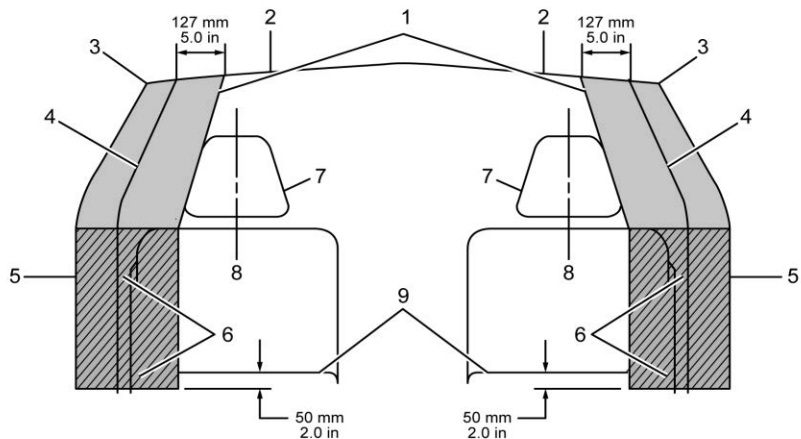

**Roof-Rail Side Impact Airbags, Driver and Passenger Deployment Zones
– View from Rear Cargo Area (Passenger, Cargo Vans, and Cutaway Models)**

1. Roof-rail Airbag Deployment Zone

2. Underside of Headliner

- 3. Edge of Headliner
- 4. Inner Pillar Trim
- 5. Inner Front Door Trim
- 6. Front Seatback Side Deployment Zone
(520 mm (20.5 in) Above Seat Cushion) (180 mm (7.1 in) From Door Trim)
- 7. Front Seatback and Headrest
- 8. Seat Centerline
- 9. Top of Seat Cushion

The driver and passenger seat-mounted side impact airbag deployment zones move up, down, fore, and aft, as the seat is adjusted by the occupant. The deployment zones also move as the seatback is reclined and raised.

See *Customer-Installed Equipment*
⇨ 4.

Index

A

- Airbags
 - Deployment Diagrams 6
 - Questions and Answers About Airbags and Specialty Law Enforcement Vehicles 3

C

- Canadian Vehicle Owners 2
- Customer-Installed Equipment 4

D

- Deployment Diagrams 6

E

- Equipment 4

I

- Introduction 2

Q

- Questions and Answers About Airbags and Specialty Law Enforcement Vehicles 3

S

- Supplement
 - Using 2

U

- Using This Supplement 2

V

- Vehicle
 - Canadian Owners 2