

PROCEDURE FOR HANDLING CHASSIS/DEALER CLAIMS

General

All chassis tendered for delivery by the Transportation Company are to be accepted by the Body Company. If a chassis has been damaged or is short certain parts when received by the Body Company, they will repair or replace missing parts, if possible, with their own or other local facilities and promptly forward the claim to the dealer.

If the Body Company or other local facilities are not adequate for replacing missing or damaged parts, the Body Company will promptly notify the Dealer and hold damaged chassis awaiting his instructions. The Dealer must be notified promptly upon receipt of a chassis on which a claim is in order giving the "model", "engine number," and "serial number" and what the damage or shortage consisted of. This is important since Chevrolet/GMC Truck cannot accept claims from the Dealer unless filed within thirty days from date of delivery, or unless within the thirty-day period, the Dealer has advised Chevrolet/GMC Truck that a claim will be filed. Delivery to the Body Company constitutes delivery to the Dealer, since the Body Company is the Dealer's agent.

Completed vehicles that are to be driven to the Dealer or the Dealer's customer must first be serviced by the Body Company at the Body Company's location in accordance with Chevrolet/GMC Truck new vehicle conditioning procedures. Expenses incurred for this condition are the responsibility of the selling Dealer.

Shipments Received from Truckaway or Driveaway Company

The Body Company will inspect condition of chassis and call driver's attention to damage or missing parts and make a detailed notation of both copies of Transportation Company's delivery receipt of the nature and extent of the existing damage and/or shortage and have driver sign such notation on the Dealer's copy. If chassis are received after business hours and cannot, therefore, be adequately inspected, the delivery receipt (both copies) is to carry notation "Received subject to inspection" and show the time and date. On such chassis, a detailed inspection must be made within 24 hours or on the first working day after receipt of chassis and immediately furnish to the Dealer. Any exceptions are to be noted on both copies of the delivery receipt by the Body Company.

If Received from Railroad

Freight car should be opened and contents inspected in presence of railroad representative before starting to unload, and any existing damage or shortage recorded by the railroad representative on his standard inspection report. Body Company must secure from railroad agent, a copy of his inspection report detailing nature and extent of the damage and/or shortage.

If the railroad representative does not comply with consignee's request to make an inspection, then the Body Company will immediately confirm his request (in writing) to the railroad agent, outlining the nature and extent of damage and/or shortage disclosed by consignee's inspection, prior to starting any unloading operations, sending a copy of his letter to the Dealer.

Filing a Claim

Upon completion of repairs or replacements of missing parts, the Body Company will promptly bill the Dealer for the cost involved, supporting such debit with a detailed statement showing how the amount is arrived at end either the original delivery receipt with notation if received from a truckaway company or the carrier's inspection report if received from a railroad.

Disposition of Damaged Parts

Damaged parts removed from chassis by the Body Company must be held for disposition orders from the Dealer.

Dealer claims will not be allowed unless above instructions are fully complied with.

GOVERNMENT REGULATIONS









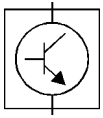

Introduction

The Federal Government has established Motor Vehicle Safety Standards for various categories of motor vehicles and motor vehicle equipment under the provisions of the National Traffic and Motor Vehicle Safety Act of 1966. The Act imposes important legal responsibilities on manufacturers, dealers, body builders and others engaged in the manufacturing and marketing of motor vehicles and motor vehicle equipment.

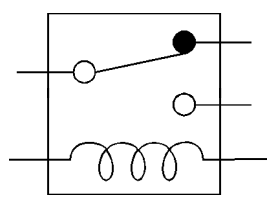
Questions dealing with the specific application of the Act or the standards to your business should be discussed with your legal counsel. This is particularly so because the standards and other requirements or interpretations are subject to change by the government agency in charge, the National Highway Traffic Safety Administration.

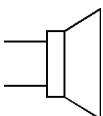
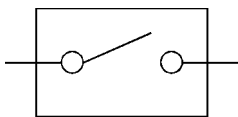
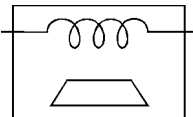
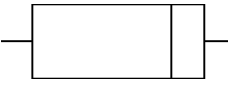
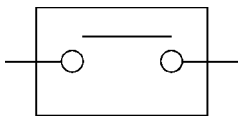
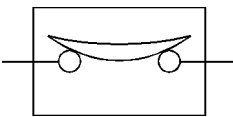
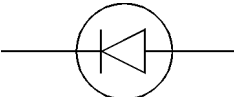
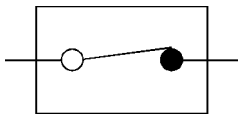
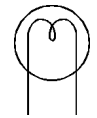
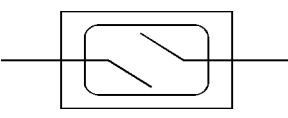
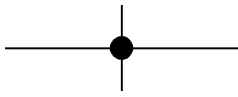
New standards and amendments issued by the National Highway Traffic Safety Administration will appear in the Federal Register from time to time. You may obtain the Federal Register, through the Superintendent of Documents, U.S. Government Printing Office, Washington, D.C. 20402.

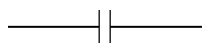
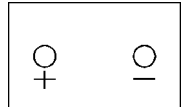
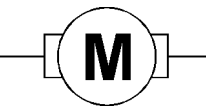
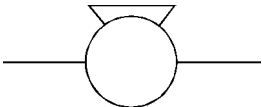
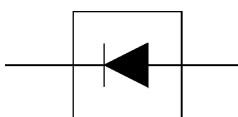
SYMBOLS

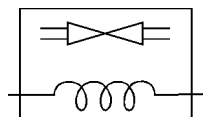
Symbol	Meaning	Symbol	Meaning	Symbol	Meaning
	Fuse		Electronic Parts		Coil (Inductor), Solenoid Magnetic Valve
	Fusible Link		Resistor		Relay
	Fusible Link Wire		Speaker		
	Switch		Buzzer		Connector
	Switch		Circuit Breaker		Light Emitting Diode
	Switch (Normal Close Type)		Bulb		Reed Switch
	Contact Wiring		Double Filament Bulb		Condenser
	Battery		Motor		Horn
	Diode		Variable Resistor Rheostat		Vacuum Switching Valve

ABBREVIATIONS

Abbreviation	Definition	Abbreviation	Definition
A	Ampere (S)	kW	kilowatt
ABS	Anti-lock Brake System	LH	Left Hand
ASM	Assembly	LWB	Long Wheel Base
AC	Alternating Current	M/T	Manual Transmission
A/C	Air Conditioner	OD	Over Drive
ACC	Accessories	OPT	Option
A/T	automatic Transmission	QOS	Quick on Start
C/B	Circuit Breaker	RH	Right Hand
CSD	Cold Start Device	RR	Rear
DIS	Direct Ignition System	RWAL	Rear Wheel Anti-Lock Brake System
EBCM	Electronic Brake Control Module	ST	Start
ECGI	Electronic Control Gasoline Injection	STD	Standard
ECM	Electronic Control Module	SW	Switch
ECU	Electronic Control Unit	SWB	Short Wheel Base
EFE	Early Fuel Evaporation	TCM	Transmission Control Module
4A/T	4-Speed Automatic Transmission	3A/T	3-Speed Automatic Transmission
4 X 4	Four-Wheel Drive	V	Volt
FL	Fusible Link	VSV	Vacuum Switching Valve
FRT	Front	W	Watt (S)
H/L	Headlight	WOT	Wide Open Throttle
IC	Integrated Circuit	W/	With
IG	Ignition	W/O	Without

WIRING

Wire Color

All wires have color-coded insulation. Wires belonging to a system's main harness will have a single color. Wires belonging to a system's sub-circuits will have a colored stripe. Striped wires use the following code to show wire size and colors.

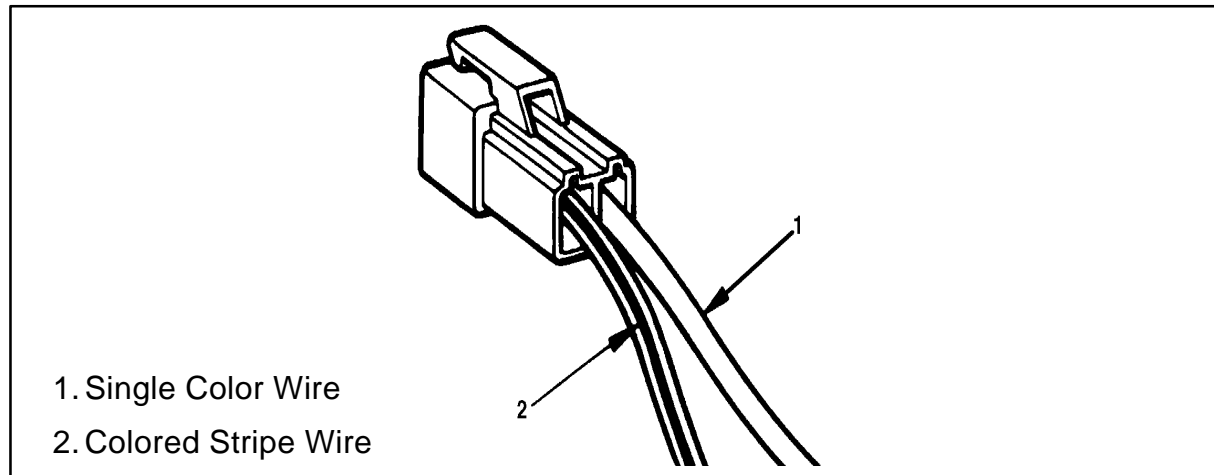
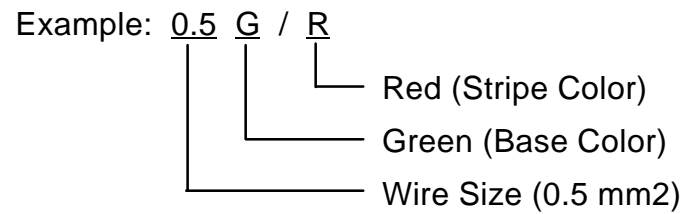

Abbreviations are used to indicate wire color within a circuit diagram. Refer to the following table

Color-Coding	Meaning	Color-Coding	Meaning
B	Black	BR	Brown
W	White	LG	Light Green
R	Red	GR	Grey
G	Green	P	Pink
Y	Yellow	LB	Light Blue
L	Blue	V	Violet
O	Orange		

Distinction of Circuit by Wire Base Color

Base Color	Circuits	Base Color	Circuits
B	Starter Circuit	Y	Instrument Circuit
W	Charging Circuit	L, O, BR, LG, GR, P, LB, V	Other Circuits
R	Lighting Circuit		
G	Signal Circuits		

Wire Size

The size of wire used in a circuit is determined by the amount of current (amperage), the length of the circuit, and the voltage drop allowed. The following wire size and load capacity, are specified by AWG (American Wire Gauge) (Nominal size means approximate cross sectional area).

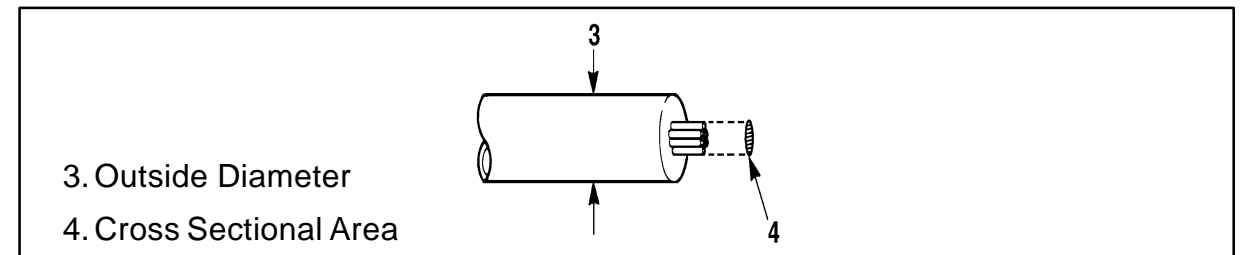

Nominal Size	Cross Sectional Area (mm ²)	Outside Diameter (mm)	Allowable Current (A)	AWG Size (Cross Reference)
0.3	0.372	1.8	9	22
0.5	0.563	2.0	12	20
0.85	0.885	2.2	16	18
1.25	1.287	2.5	21	16
2	2.091	2.9	28	14
3	3.296	3.6	37.5	12
5	5.227	4.4	53	10
8	7.952	5.5	67	8
15	13.36	7.0	75	6
20	20.61	8.2	97	4

GROUNDING POINT LOCATION

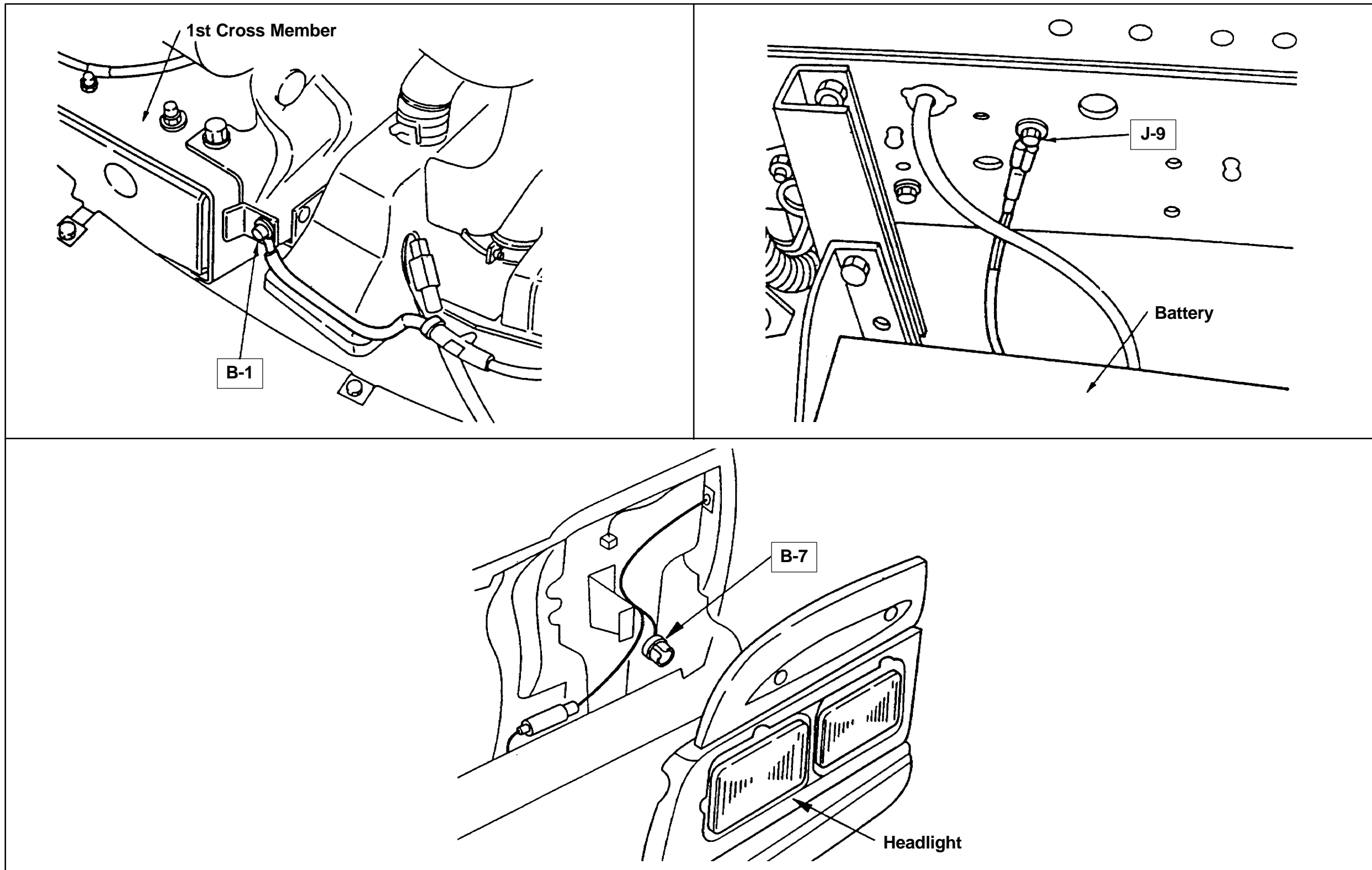

REFERENCE TABLE OF GROUNDING POINT

NOTICE: Abnormal phenomena of electrical components are considered resulted from defective grounding. In repair, be sure to inspect grounding points and to tighten all fastening parts surrounding the grounding points.

Connector No.	Cable Harness Name	Location	Main Parts (Load)
B-1		Frame-LH (FRT)	Vehicle speed sensor, QOS-III Control unit, Turn signal indicator light, Meter, High beam indicator light.
B-7	Body Harness	Headlight Bracket-LH	Change relay, Exhaust brake relay, QOS-III control unit, Dome light switch, Meter, Brake fluid switch, Tail relay, Cornering light relay, Dimmer relay, Wiper motor, Washer motor intermittent relay, Heater & A/C relay, Radio & clock, Cigar lighter, Fan switch, Blower resistor, A/C Switch, Blower motor, Electronic thermostat, Accel switch, Van interior switch, Flasher unit, Engine warming up switch, Clearance light, ID light, Illumination control switch OD OFF switch, Kick down switch, Electronic vacuum pump, Power source relay.
J-9	Frame Front Harness	Frame-LH (CRT)	Fuel tank unit, Starter relay, Neutral switch, Pressure switch, Exhaust brake control relay, Exhaust brake magnetic valve, Accel switch, Clutch switch, Engine stop motor, Inhibitor switch, Thermo switch (Eng. warm), VSV: Fuel throttle, Thermo switch (Fuel throttle), Engine warming cut relay, ID relay, Condenser fan relay, Condenser fan

BODY ROOM LIGHT, ID & MARKER LAMP CONNECTOR LOCATION

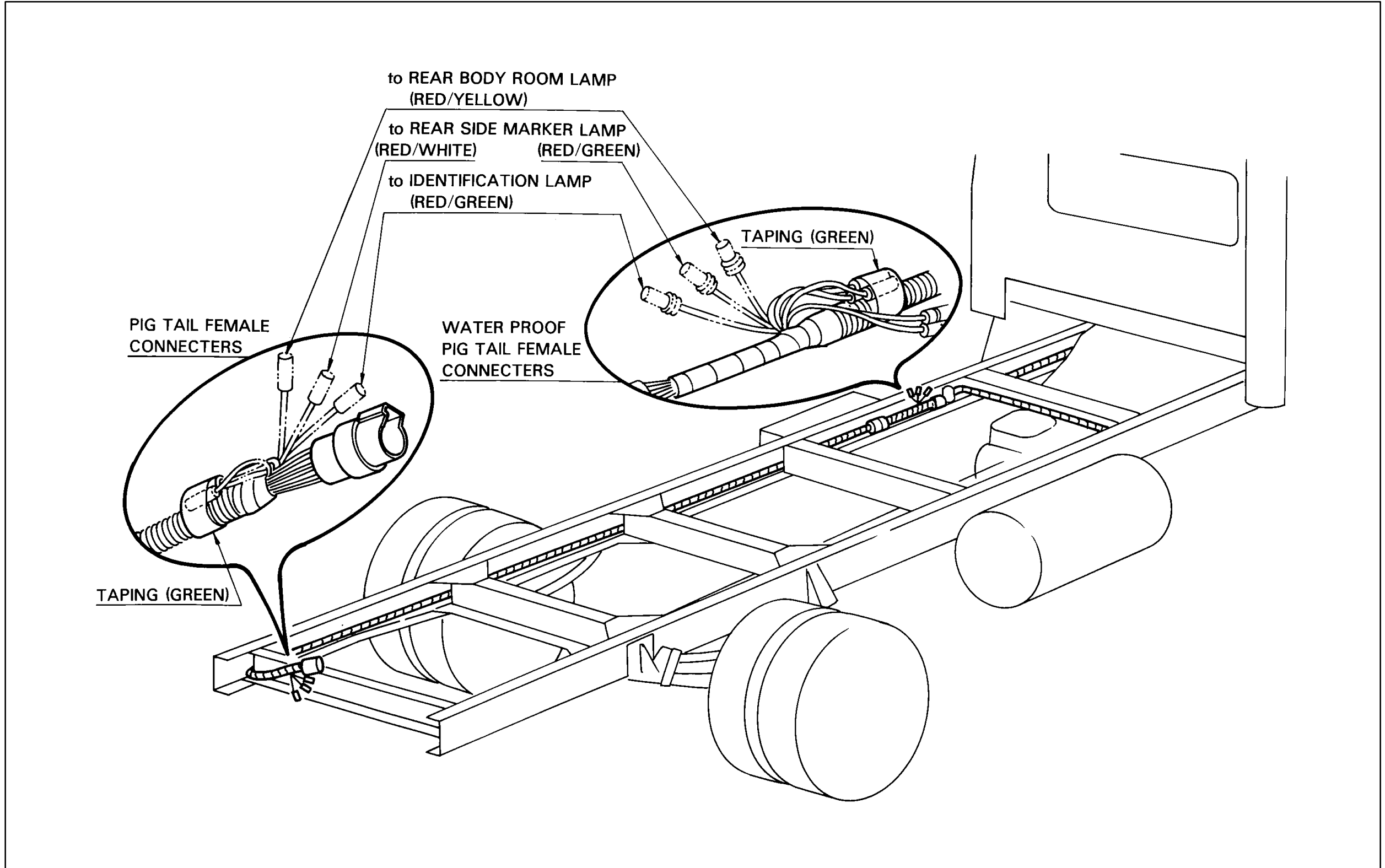

CIRCUIT DIAGRAM BODY ROOM LIGHT

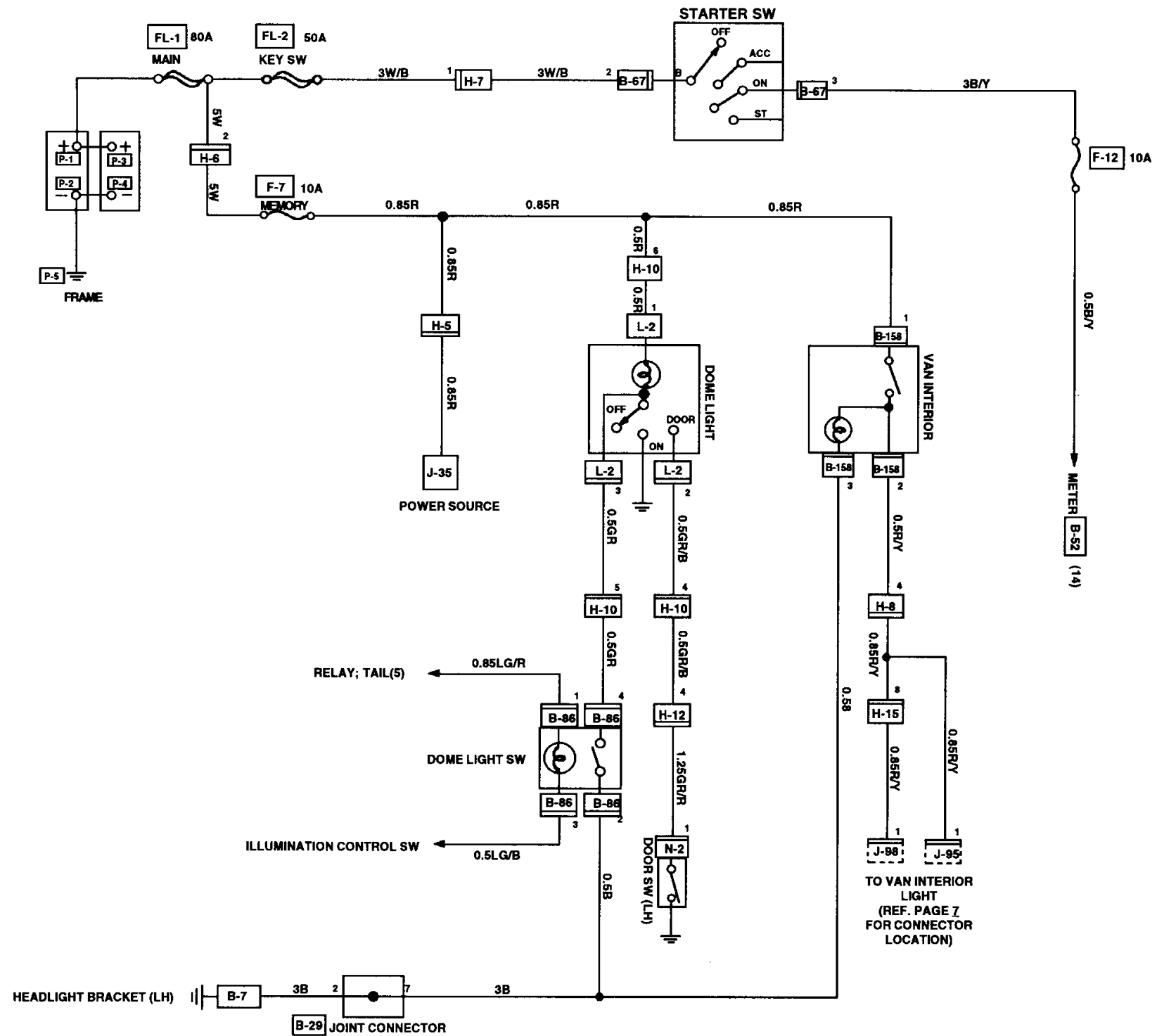

CIRCUIT DIAGRAM BODY ID & MARKER LIGHTS

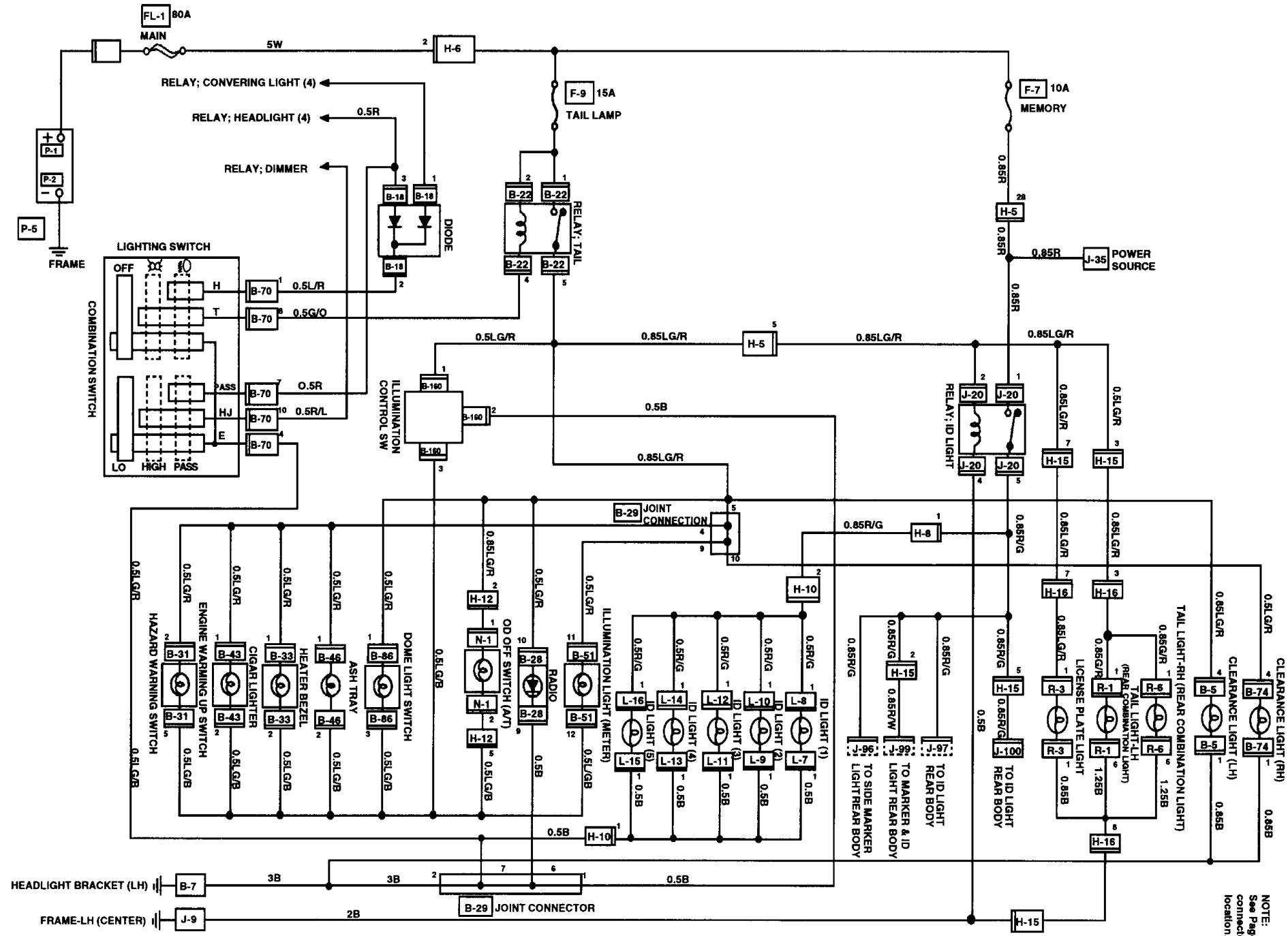

NOTE:
See Page 2 for
connector
location.

FUSE AND FUSIBLE LINK LOCATION

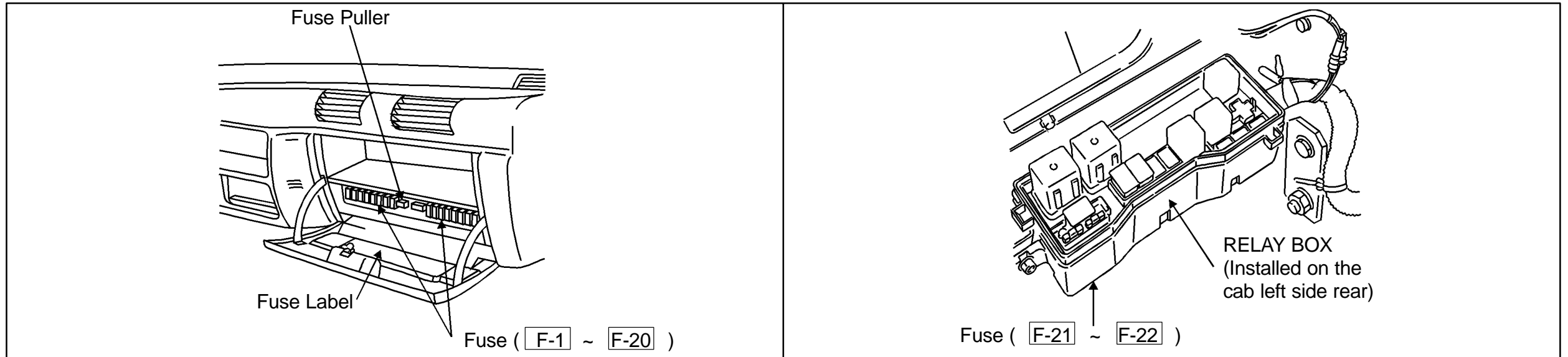

Fuse Label

Fuse	Label	Fuse	Label	Fuse	Label		
25A ①	HEATER	15A ⑪	WIPER, WASHER	10A F-21			
10A ②	AIR CONDITIONING	10A ⑫	METER, BACK	15A F-22	CONDENSER FAN		
10A ③	STARTER	10A ⑬	ECU (IGN)	<p>NOTICE: The fuse numbers ①~⑳ indicated on the fuse labels are expressed as F-1~F-20 in the circuit diagrams of this manual.</p>			
15A ④	RADIO, CIGAR	15A ⑭	FUEL HEATER				
15A ⑤	HEAD LAMP (RH)	10A ⑮	EXHAUST BRAKE				
15A ⑥	HEAD LAMP (LH)	10A ⑯	ECU (BAT)				
15A ⑦	MEMORY	10A ⑰	TURN S/LAMP				
15A ⑧	HAZARD, HORN	15A ⑱	GENERATOR				
15A ⑨	TAIL LAMP	10A ⑲	ENGINE STOP				
10A ⑩	STOP LAMP	20A ⑳	PISOURCE				
20A	BREAKER						

FUSE BLOCK CIRCUIT

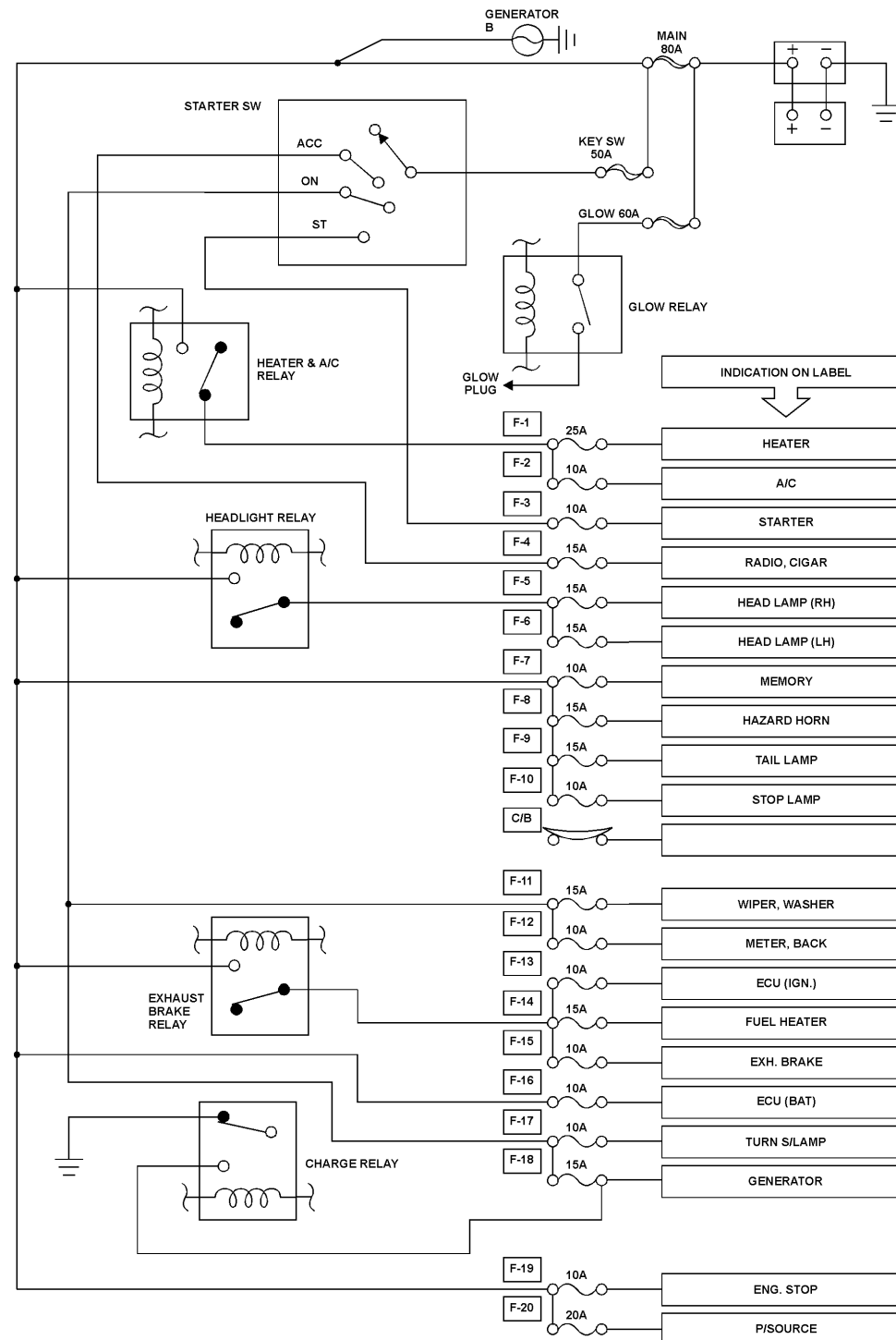

REFERENCE TABLE OF FUSE

Fuse No.	Capacity	Indication on Label	Main Parts (Load)
F-1	25A	HEATER	Blower motor, Blower resistor, Fan switch, A/C switch, A/C thermo relay, Pressure switch, Electronic thermostat
F-2	10A	AIR CONDITIONER	A/C switch, A/C thermo relay, Pressure switch, magnetic clutch, Electronic thermostat, Condenser fan relay
F-3	10A	STARTER	Starter relay, Inhibitor switch, QOS-III controller, Neutral switch
F-4	15A	RADIO, CIGAR	Cigar lighter, Radio, Power source relay
F-5	15A	HEAD LAMP (RH)	Headlight (RH), Dimmer relay, High beam indicator light
F-6	15A	HEAD LAMP (LH)	Headlight (LH), Dimmer relay, Cornering light relay, Cornering light, Cornering light switch
F-7	10A	MEMORY	Radio & clock, Dome light switch, Dome light, Door switch (LH), ID light relay, ID light, Van interior switch
F-8	15A	HAZARD, HORN	Hazard warning switch, Horn, Horn relay, Horn switch, Flasher unit
F-9	15A	TAIL LAMP	Tail relay, Illumination light(s), Lighting switch, Clearance light(s), Tail light(s), Illumination control switch, ID light relay
F-10	10A	STOP LAMP	Stoplight switch, Stoplight
F-11	15A	WIPER, WASHER	Wiper & Washer switch, Wiper motor, Washer motor, Intermittent relay
F-12	10A	METER, BACK	Exhaust brake control relay, Backup light switch, Backup light, Inhibitor switch, Neutral switch, QOS-III controller, Glow-1 relay, Glow-2 relay, Glow indicator (Meter), Coolant temperature gauge, Thermo unit, Vehicle speed sensor (Installed on the meter assembly & transmission), Meter assembly, Cornering light relay, Thermo switch (Fuel throttle) VSV: Fuel throttle, Idol switch Vacuum pump relay, Electronic vacuum pump
F-13	10A	ECU (IGN)	TCM
F-14	15A	FUEL HEATER	—
F-15	10A	EXH. BRAKE	Exhaust brake switch, Exhaust brake control relay, Exhaust brake magnetic valve, Clutch switch, Accel switch, Engine warming up switch, Engine warming cut relay, Thermo switch (Eng. warm)
F-16	10A	ECU (BAT)	TCM
F-17	10A	TURN S/LAMP	Flasher unit, Front turn signal light, Rear turn signal light, Turn signal light switch, Hazard warning switch
F-18	15A	GENERATOR	Generator, Charge relay, QOS-III controller, Exhaust brake relay
F-19	10A	ENG. STOP	Engine stop motor
F-20	20A	PISOURCE	Power source relay, Power source
F-21	—	—	—
F-22	15A	CONDENSER FAN	Condenser fan relay, Condenser fan

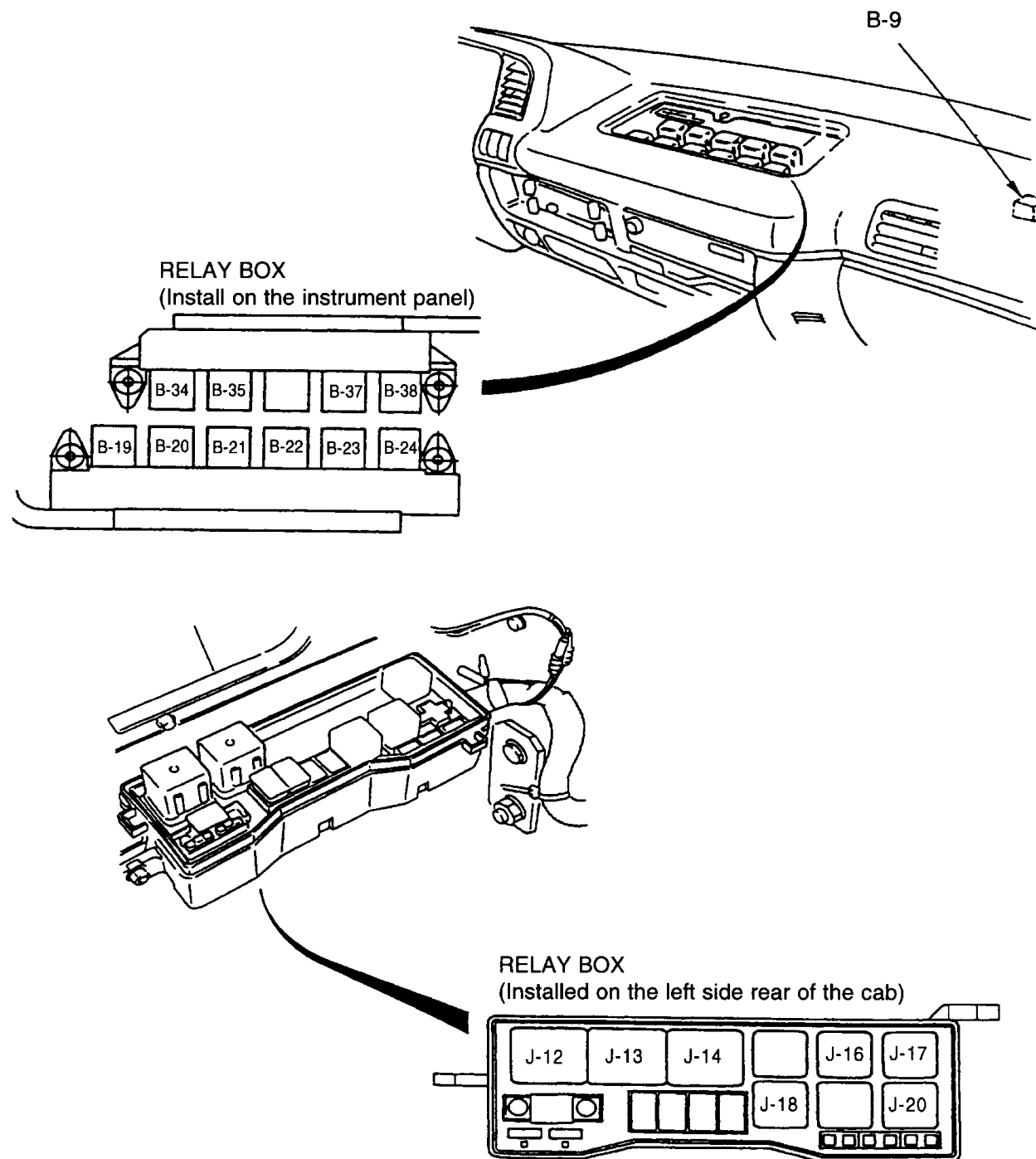
RELAY LOCATION

RELAY LIST

Connector No. Relay Name	B-9 Intermittent	B-19 Charge	B-20 Head light	B-21 Heater & A/C	B-22 Tail
Connector No. Relay Name	B-23 Dimmer	B-24 Horn	B-34 Aux. Power Source	B-35 Cornering Light	B-37 A/C Thermo
Connector No. Relay Name	B-38 Exh. Brake	J-12 Starter	J-13 Glow-1	J-14 Glow-2	J-16 Eng. Warming Out
Connector No. Relay Name	J-17 Condenser Fan	J-18 Exh. Brake Control	J-20 ID Light		

CIRCUIT DIAGRAM AUXILIARY POWER SOURCE

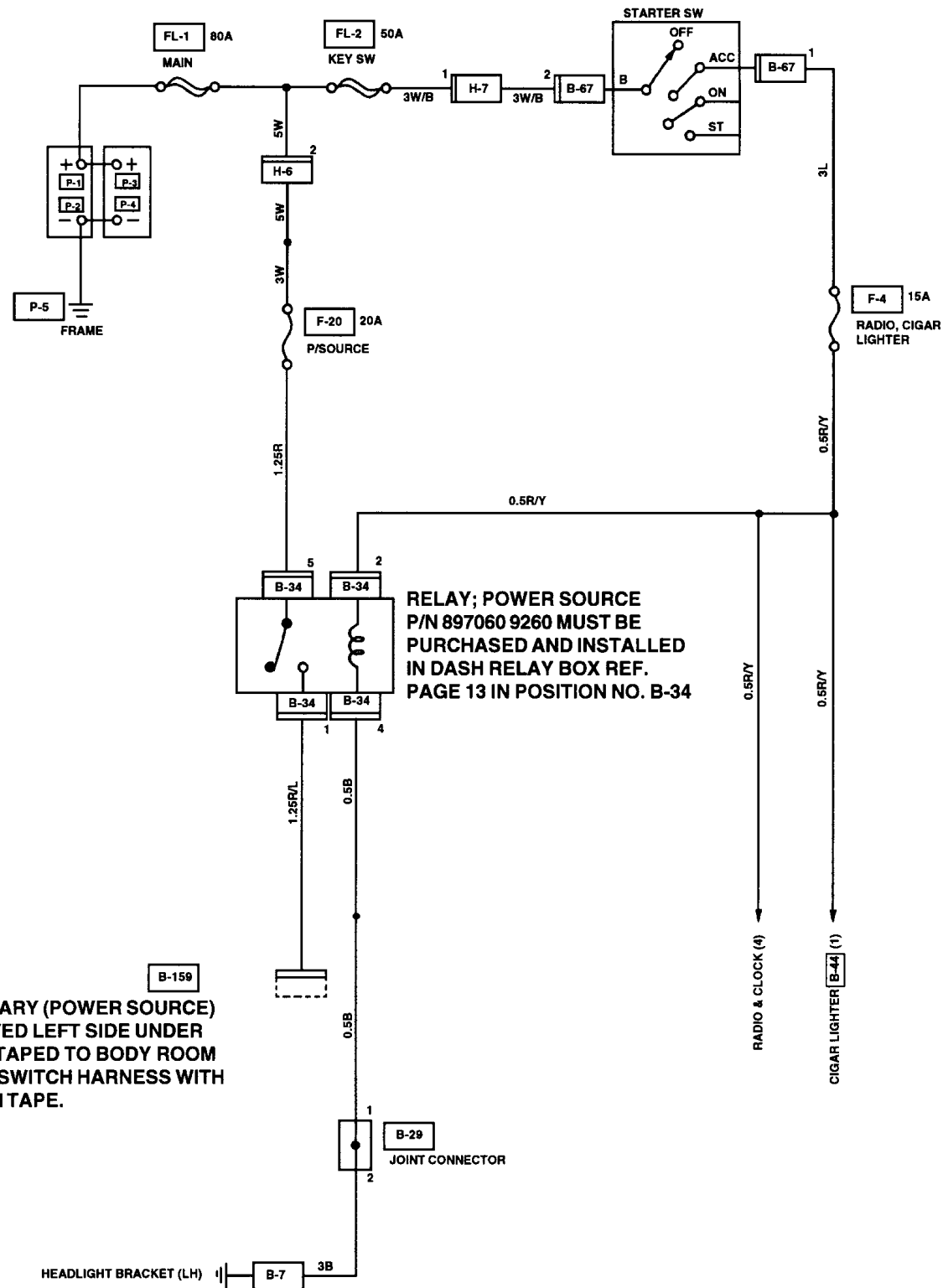

CIRCUIT DIAGRAM ACCESSORY WIRING

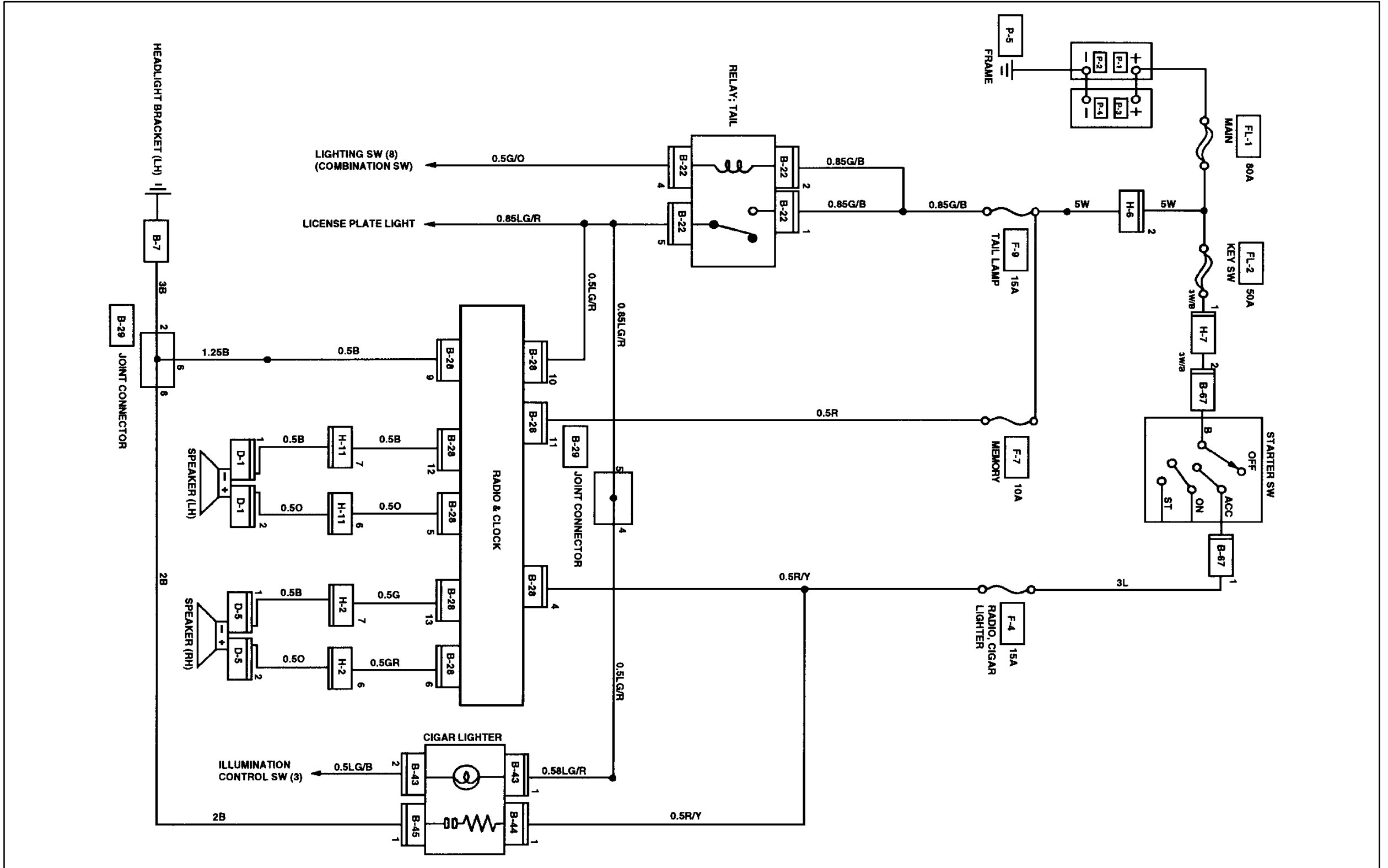

CIRCUIT DIAGRAM HORN AND BACK-UP LIGHT

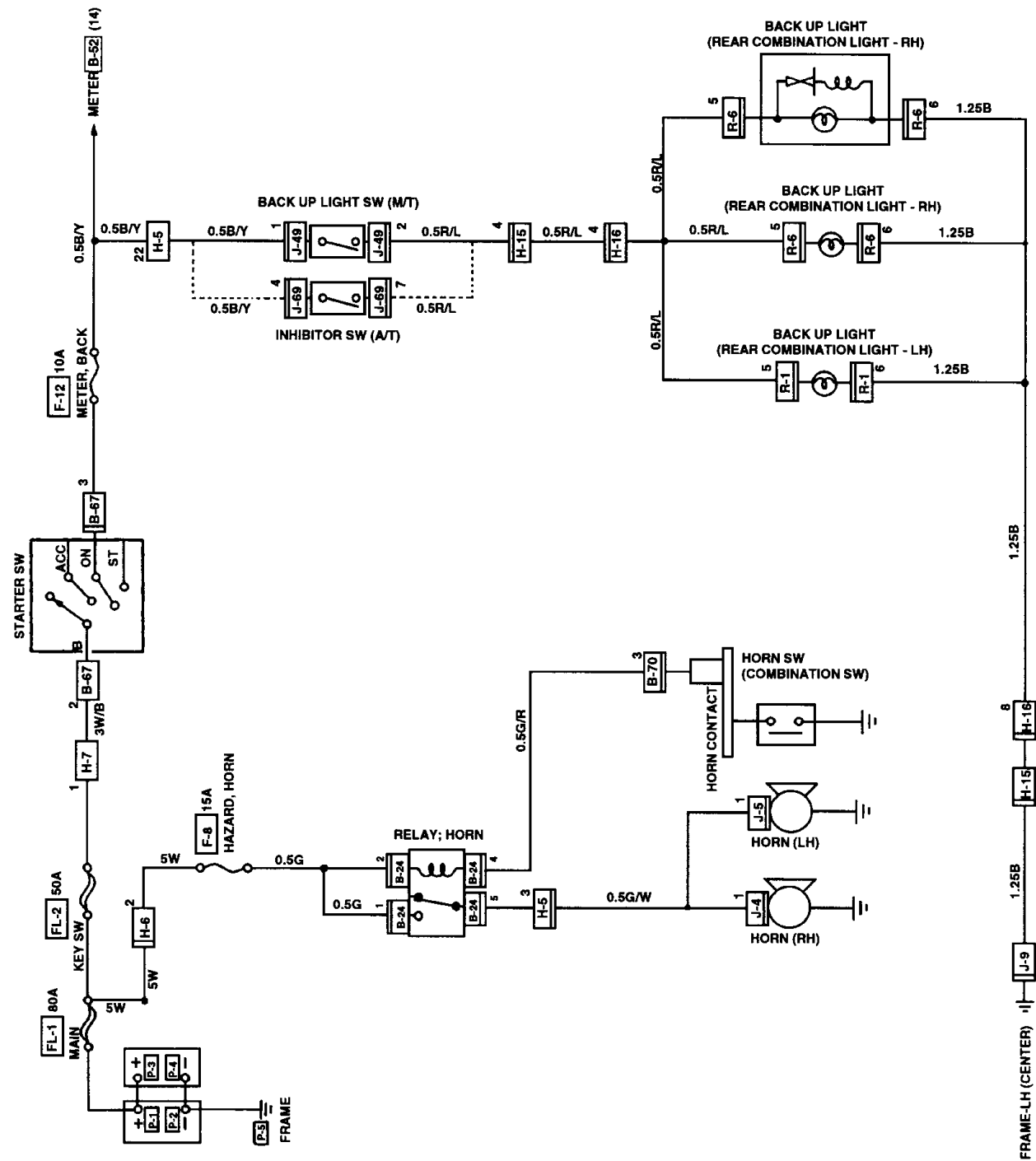

CIRCUIT DIAGRAM ENGINE STOP MOTOR

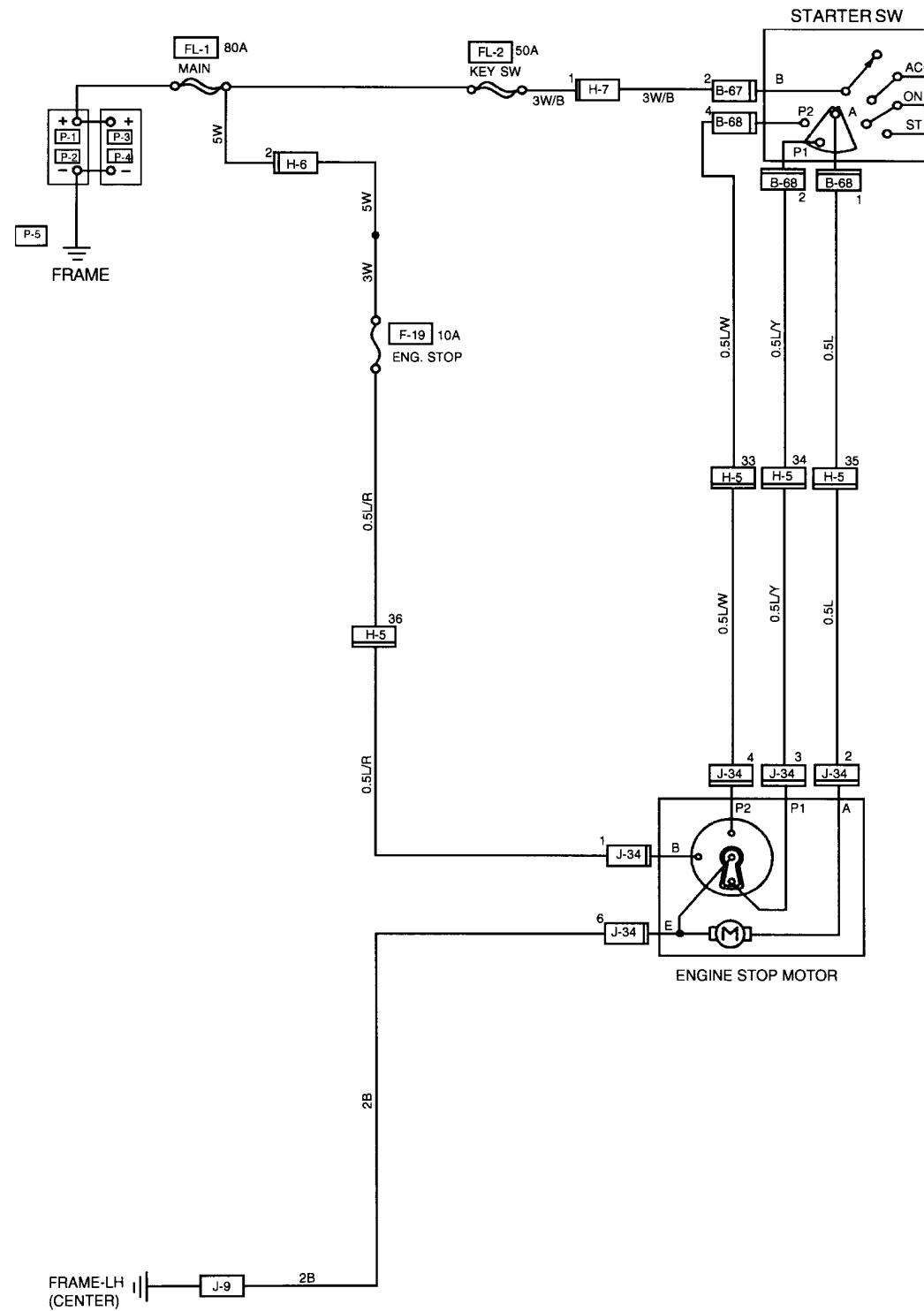

FUEL TANK SENDING UNIT RESISTANCE

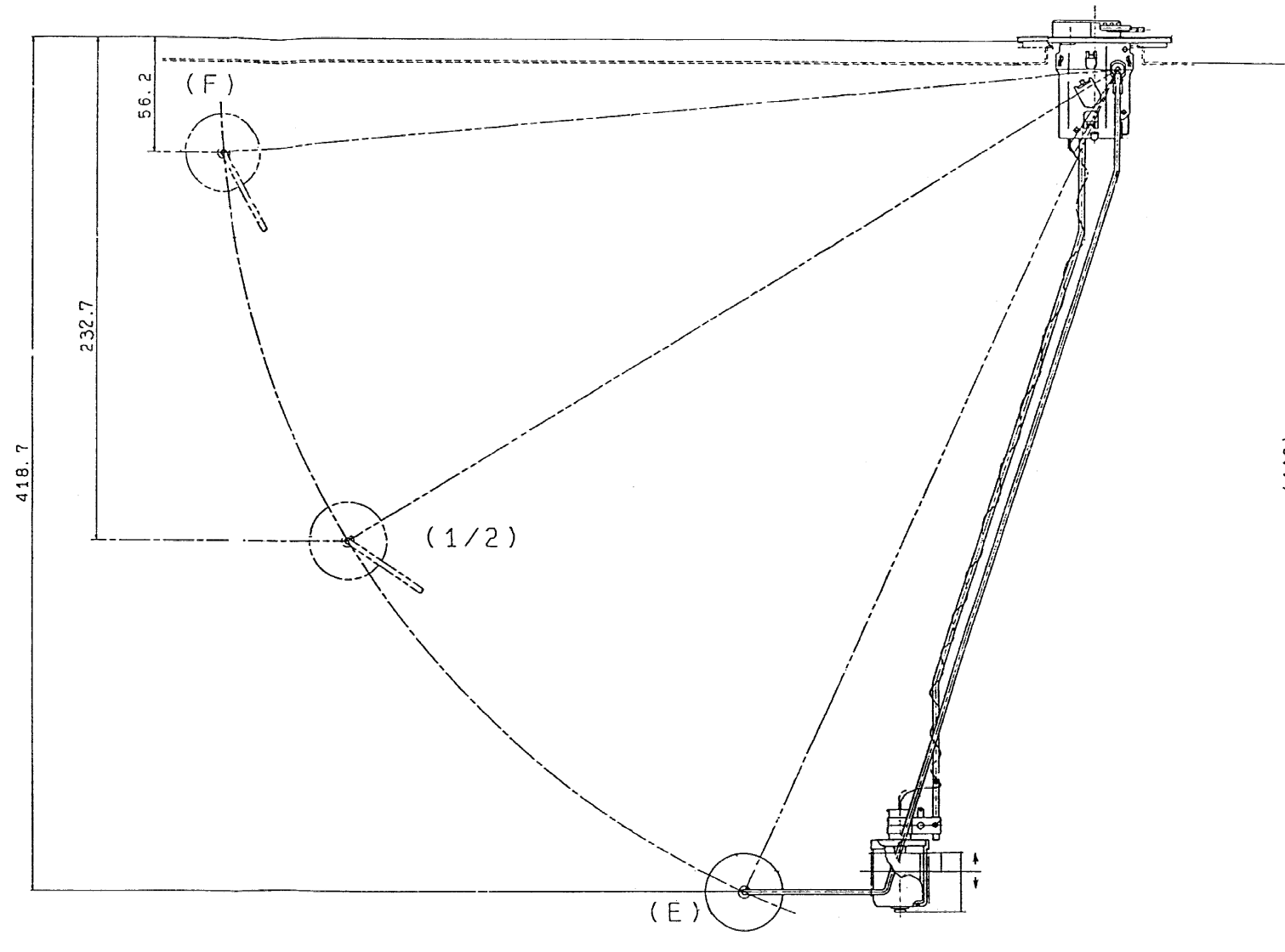

Float Position	Resistance Value (Ω)
F	3 ± 2.1
1/2	$32.5 \pm \times 4.8$
E	110 ± 7.7