

| | |
|---|-----------|
| BODY BUILDERS INSTRUCTIONS | 1 |
| Section 0 – General Instructions | 1 |
| Section 1 – Body | 2 |
| Conversions | 3 |
| Air Conditioning | 3 |
| Rear Air Conditioning | 3 |
| Section 2 – Frame | 4 |
| Holes | 4 |
| Welding | 4 |
| Alterations | 5 |
| Section 3 – Front Suspension | 5 |
| Section 4 – Rear Suspension | 5 |
| Section 5 – Brakes | 6 |
| Section 6 – Engine | 6 |
| Section 7 – Transmission | 9 |
| Section 8 – Fuel and Exhaust | 9 |
| Fuel Systems | 9 |
| Fuel Fill | 9 |
| Fuel Lines | 10 |
| Fuel Tank | 10 |
| Exhaust System | 11 |
| Section 9 – Steering | 12 |
| Section 10 – Tires | 12 |
| Section 12 – Electrical Battery and Battery Cables | 13 |
| Accessory Power Supply Feeds | 15 |

BODY BUILDERS INSTRUCTIONS – *Continued*

| | |
|--|-----------|
| Section 13 – Heating/Cooling | 16 |
| Valve Sources: | 16 |
| CHASSIS | |
| M/L 11005 General Arrangement, Exterior | 17 |
| M/L 11006 General Arrangement, Exterior | 18 |
| M/L 110(05, 06) General Arrangement, Interior | 19 |
| M/L 110(05, 06) General Arrangement, Interior | 20 |
| BODY | |
| M/L 110(05, 06F) Bumper, Tailgate and Dutch Door | 21 |
| M/L 110(05, 06) Seat Mounting Hole Locations | 22 |
| M/L 110(05, 06) Roof Rack Mounting | 23 |
| FRAME | |
| Refer to Chassis – General Arrangement | 17-20 |
| AXLE/SUSPENSION | |
| Refer to Chassis – General Arrangement | 17-20 |
| FUEL TANK | |
| Refer to Chassis – General Arrangement | 17-20 |
| EXHAUST | |
| Refer to Chassis – General Arrangement | 17-20 |
| ELECTRICAL | |
| Ordering Information | 24 |

NOTE: This vehicle has two air bags – one air bag for the driver and another air bag for the right front passenger. To help prevent unwanted inflation, see GM Service Manual for Diagnostic and Service Procedures before performing any service.

BODY BUILDERS INSTRUCTIONS

The Incomplete Vehicle Document (IVD) is supplied with each incomplete vehicle, and provides information that should be used by intermediate and final stage manufacturers in determining conformity to applicable Federal Motor Vehicle Safety Standards (FMVSS). The IVD also includes information which must be followed in order to ensure that Environmental Protection Agency (EPA) and California emissions certification requirements and NHTSA Fuel Regulations are met.

The Body Builders Book contains information that may be used in addition to the IVD for any manufacturer making alterations to a GM complete/incomplete vehicle. No alteration should be made to the incomplete vehicle which either directly or indirectly results in any component, assembly or system being in nonconformance with any applicable Federal Motor Vehicle Safety Standard or Emission Regulation. Intermediate and final stage manufacturers should be familiar with all Federal Motor Vehicle Safety Standards and Emission Regulations and aware of their specific responsibilities as manufacturers.

For further assistance contact Upfitter Integration at: 1 (800) 875-4742, or go to our Web site at "<http://www.gmupfitter.com>."

Section 0 – General Instructions

Check for proper clearance between body members and chassis components which may in any way affect the reliability and performance of the vehicle by developing abrasion and wear points from moving parts or degradation from extreme environment or thermal exposure or may increase interior noise.

Check headlamp aim and all vehicle illumination systems for proper operation when the vehicle has been completed. Re-aim headlamps when necessary. Check for proper operation of windshield washer, wipers and defroster system.

Extreme care must be taken when working on vehicles equipped with Engine Control Module (ECM), Powertrain Control Module (PCM), Transmission Control Module (TCM), Vehicle Control Module (VCM) or any electronic unit associated with an inflatable restraint system. (See Owner's Manual).

If arc-welding is employed on the chassis, precautions must be taken to protect all vehicle components, especially brake, fuel lines and fuel tank assembly, electrical wiring and ECM/PCM/TCM or VCM. To avoid electronic component damage, disconnect battery (batteries); disconnect the negative cable first, followed by the positive. To reconnect cables; connect the positive first, then the negative.

When welding components to the frame assembly, remove the wax coating in the area of the weld in order to obtain secure welds. After completion of the weld, a compatible corrosion protection should be applied to the affected weld areas.

(Section 0 – continued on next page)

(Section 0 – continued from previous page)

Due to the metal thickness used in the “Unitized” chassis-body structure, welding heat must be carefully controlled to avoid burn-through and loss of structural integrity.

All labels on the vehicle (any message applied to the vehicle or vehicle component that informs, instructs, or warns) must appear on the completed vehicle so the user can read them easily and without obstruction.

Service and service replacement parts for your add-on systems may not be available from a GM dealer. Those installing aftermarket systems should provide information as to where and how to obtain service.

Section 1 – Body

Accessory items such as refrigerator, hot water heater, furnace, etc., which operate on liquid propane gas should be located and protected to prevent exposure to any flame.

Body structures, interior and accessory arrangements must be designed into the vehicle to provide for proper load distribution on both axles and not to exceed any gross axle weight ratings. Lateral load equalization must also be maintained. The resultant Center of Gravity of the unladen vehicle must be within the limits tabulated in the FMVSS 105 section of the Incomplete Vehicle Document.

Body insulation provided by General Motors should not be removed. This includes any thermal or underbody heat shields. This insulation is provided to protect the vehicle body and occupants from excessive heat and/or provide noise attenuation. Any replacement material internal to the occupant compartment must be certified for MVSS standard on flammability. Areas of specific concern, but not limited to are:

- Underbody exhaust, muffler and tail pipe shields and insulators.
- Rear load floor interior insulation.
- Front floor interior insulation.
- Dash mat insulation.
- Engine cowl insulation-interior and exterior.
- Engine cover insulation.

For vehicles equipped with RPO E54 (alternate rear doors), the door inner panels must be sealed to prevent intrusion of carbon monoxide and other exhaust fumes into the passenger compartment.

(Section 1 – continued on next page)

(Section 1 – continued from previous page)

Conversions

Conversions which remove roof bow behind front doors must provide equivalent tie-in between door pillars.

A minimum of 10' departure angle should be maintained if frame and/or body is extended.

If body builder installs seating other than that supplied with vehicle, it is the body builder's responsibility to ensure that the seating and restraint systems comply with FMVSS requirements. The restraint systems supplied with the vehicle were designed to accommodate the seating reference points and seat travel of the original equipment seats only.

Air Conditioning

For additional information refer to **Engine - Section 6**.

NOTE: Air conditioning systems using R-134A refrigerant are equipped with metric fittings to prevent interchange with R-12 refrigerant components. Do not interchange R-134A components, refrigerant oil or service equipment with R-12 components, refrigerant oil or service equipment.

Rear Air Conditioning

This unit may be equipped with A/C quick-connect fittings (Option YF7) on the liquid tube (high pressure) and the suction (low pressure) return tube. These fittings are designed to accept matching Aeroquip connecting fittings attached to pre-charged lines. This allows a one time only connection to the O.E.M. charged A/C system without having to discharge, evacuate and recharge for the connection of a rear A/C system.

A modification to the A/C system which causes the A/C plumbing lines to increase in length (such as the addition of a rear after-market evaporation and blower assembly) will necessitate the following changes:

- Lubrication – PAG refrigerant oil must be added to rear system to provide lubrication for compressor. Refer to Service Manual for specifications.
- Refrigerant – Add R-134A refrigerant to system based on sizing of new tubes, hoses and evaporator. Contact your A/C supplier for recommended charge.
- Label – Revise/modify GM charge label (located on top of front evaporator) from factory recommended charge for a front system only to body builder's new recommended dual system per SAE J639. This is important for servicing the A/C system so that the technician knows the correct amount to add to the modified system.

(Section 1 – continued on next page)

(Section 1 – continued from previous page)

If this unit is equipped with quick-connect fittings and is not converted to a dual system, the temporary protective caps must be replaced with Aeroquip type metal caps.

M/L Vans with R-134A use hoses with nylon lines. These hoses are **not** suitable for field crimping operations. It is **not** recommended to cut into the hoses for addition of add-on auxiliary A/C systems.

Section 2 – Frame

Hole drilling, welding, modifications, or alterations to the frame assembly are the responsibility of persons performing these operations. These same individuals assume complete responsibility for frame assembly reliability, performance after alterations and compliance to applicable FMVSS requirements.

Holes

Holes to mount brackets, supports, and out-riggers must be drilled with the following restrictions:

- Material between edge of hole and inside of upper or lower flange must not be less than 37 mm (1.50 in.) for low carbon steel.
- The minimum edge distance between any two (2) holes must be larger than twice the diameter of the larger hole.
- No holes should exceed 20 mm (0.75 in.) in diameter.
- All holes should be drilled in the frame using appropriate drilling practice and safety precautions.

Welding

CAUTION: Fuel tank and fuel lines must be drained and all vapors purged to ensure non-combustible mixture before any welding, brazing or soldering.

When welding low carbon steel side rails, crossmembers and brackets (32,000 or 36,000 PSI yield strength), emphasis is placed upon weld application techniques to avoid stress risers that may adversely affect frame operating stresses.

When welding is performed anywhere on the vehicle, precautionary measures should be taken to prevent damage to electrical system wiring or components. Prior to any welding, parts or components which could be damaged by excessive temperatures must be removed or adequately shielded; the battery cables should be disconnected at the battery. Also prior to welding, the area to be welded and surrounding area must be cleaned of all frame protective coating. After welding, when parts are cool, carefully inspect wiring and

(Section 2 – continued on next page)

(Section 2 – continued from previous page)

electrical components for shorts or other damage which could draw excessive currents and possibly cause an electrical system short when the battery is reconnected. Apply protective coating to areas where coating was removed.

Alterations

If the wheelbase is modified, the alterer must take responsibility for compliance with affected motor vehicle safety standards and for warranty on items such as driveshafts, universal joints, and rear transmission tailshaft, transfer case and transmission case fractures, output shaft bushings, bearings, brakes, fuel systems and any other related component failures. Additionally, the customer must be alerted in the modifier's owners manual that parts for the reworked area are not available through the General Motors service parts system.

Section 3 – Front Suspension

Since there is a large variation in completed vehicle front weight due to differences in body weight and equipment, the front suspension alignment must be checked and reset if necessary after the vehicle is completed. Caster and camber should be set with reference to the "A" dimensions.

See Truck Service Manual for complete alignment procedure, specifications and measurement of the "A" dimension under "Diagnosis and Front Alignment" section.

Section 4 – Rear Suspension

Clearance to body should be provided for the suspension, axle, driveshaft and tires under the following conditions: (1) Axle in full jounce against the metal-to-metal stop, (2) Axle at 4.5° roll with one side of axle in full jounce at the metal-to-metal stop and (3) Axle at design position. Allowance for the tire chain clearance shown on a maximum grown tire must allow for (1.66 in.) clearance to the sides of the tire and (2.5 in.) to the top of the tire. Be sure sufficient clearance is provided for suspension, axle and tire and wheel in full vertical travel (up and down).

NOTE: Notification to the consumer may be required in certain states if tire chains cannot be used.

Pipes, wiring, conduits and any other related components must not be placed where they cross the path of motion of the rear axle, driveshaft, axle brake pipes, hoses, spring or tires. Such crossing could result in rupture, wear-through, or separation due to normal axle motion.

Section 5 – Brakes

See Truck Service Manual for brake specifications.

Due to the critical nature of brake systems, anyone making modifications or alterations must assume complete responsibility for system reliability, performance and certification to FMVSS 105 or FMVSS 121.

It is mandatory that no change be made to the brake main cylinder location, brake pedal push rod length or pedal position.

Ensure that the hydraulic brake system is free of air and hydraulic leaks. Bleed brakes if required, following procedures as outlined in the Truck Chassis Service Manual. Ensure that the hydraulic brake booster system is functional and free of leaks.

Check master cylinder fluid level and fill as necessary. (Refer to Owner's Manual).

Added floor covering or carpeting must not restrict service or parking brake pedal travel from released position to full pedal travel.

No body part or chassis-mounted component may be located within 2.0 in. of brake hose routing in all wheel and axle positions. All exhaust system components must also have a minimum of 2.0 in. clearance to brake hoses in closest positions. (Be sure to account for brake hose travel with suspension).

Body builder is to verify that the brake warning switch is operative. The brake warning switch on models equipped with vacuum-hydraulic brakes is located adjacent to the master cylinder vacuum unit. This includes both the brake system differential pressure and parking brake actuator switch.

Section 6 – Engine

Air conditioning and auxiliary belt-driven equipment installation recommendations:

No alterations or additions to the accessory drive belt system will be warranted on either multiple belt systems or serpentine belt systems.

The serpentine belt type of drive is designed as a total system, incorporating a single poly-V belt and an automatic tensioner. In this type of system, degrees of pulley wrap, belt tension, and pulley alignment are very critical factors. Modification is not recommended.

- The addition of a pulley sheave forward of the production sheaves may subject the crankshaft and water pump bearings to loads beyond the desired limits.

(Section 6 – continued on next page)

(Section 6 – continued from previous page)

- Generally, an added load is preferable in the first belt track closest to the engine to minimize the overhang moment effect on bearings.
- Heavy or improperly balanced pulleys may contribute to bearing failure because of load induced by their mass and/or unbalance. It is extremely important (especially on the water pump) to have well-balanced and concentric pulley sheaves in order to avoid premature bearing failure. Pulley unbalance must not exceed 0.25 oz. in., and lateral and radial run out must not exceed 0.010 in. in T.I.R.
- The fan and fan clutch that come with the vehicles are matched to the equipment and conditions encountered in normal operation. Substitution of the fan and/or fan clutch may affect cooling performance. A substitute fan may be subjected to excessive stresses and might break. Substitution is therefore not allowed.
- The incorporation of an aftermarket air conditioning system could have the following consequences:
 - a. Vehicle/engine/coolant overheating in certain geographical areas that normally experience high ambient temperatures.
 - b. Restrictions to engine cooling fan airflow resulting in higher fan blade stress.
 - c. The cooling system was not designed for an A/C condenser to be mounted in front of the radiator core.
 - d. Inadequate air conditioning performance unless system capacity is enough to cool the interior space of the completed vehicle.
- Addition or relocation of pulleys behind the arc of the fan blade travel, or changes to fan fore and aft location relative to accessory drive, may alter fan stresses, and could contribute to fan blade failure. Moving the fan and/or clutch forward is also likely to overload the water pump bearing.
- The addition of air conditioning could affect conformance to FMVSS 301-Fuel System Integrity. The added equipment, in the event of an accident, could be displaced into and possibly rupture fuel system lines, hoses, filters and equipment. Care must be taken not to affect such conformance.
- The curb weight of the vehicle will be affected by the weight of the added system.
- In some single belt serpentine systems, belt tension is determined by the automatic tensioner and its position relative to the belt. No adjustment is required.

Due to the critical nature of the accelerator system, anyone making modifications or alterations assumes complete responsibility for system reliability, performance and compliance to FMVSS 124. Caution must be exercised so that the accelerator cable is properly routed. Specifications are as follows:

(Section 6 – continued on next page)

(Section 6 – continued from previous page)

- Route cable to maximize all bend radii. In no case should bend radii be less than 3 in. (76 mm).
- Minimum distance from exhaust manifold to be 6.0 in. (150 mm), unless a heat shield is provided.
- Do not use accelerator cable or clips to route wires, harnesses or other cables. Cable sheath must be clipped so as not to pinch inner cable. Cable must not be loose in clip allowing sheath to move when accelerator pedal is applied and released.
- Cable must not be subjected to kinking or routing across any sharp edges.
- Cable routing must be perpendicular to the surface of the front-of-dash at the dash fitting. No objects or routings should force cable to have a bend at the dash fitting. Flexible components (hoses, wires, conduits, etc.) must not be routed within 2.0 in. (50 mm) of moving parts or accelerator linkage unless routing is positively controlled.
- Caution must be taken so that the accelerator pedal remains properly located. Guidelines for accelerator pedal locations are as follows:
 - a. Ensure that the accelerator can freely operate from idle to wide-open throttle position and return. Make sure that the pedal will not hang up on any nearby items such as carpets, floor, screws, wiring harnesses, etc. Engine cover should have at least one inch (25 mm) clearance to side of accelerator pedal with the carpet mat installed.
 - b. Accelerator to brake pedal relationship has been designed to provide minimum driver movement and should not be altered in any way.

The gasoline engine induction and/or ignition system is certified in compliance with the Federal Vehicle Emission Standards. Any alterations to the systems or components could void compliance and render the vehicle illegal. System includes:

- Fuel system – sequential central port injector (SCPI) and associated tubes, hoses and pipes, air cleaner outside air hose and spacer heat stove and heat stove pipe, fuel pump and inlet manifold, fuel vapor canister.
- Exhaust system.
- Ignition system distributor and initial spark timing setting, sparkplugs, sparkplug wires.
- Crankcase ventilation system.
- External engine components such as air cleaner, crankcase pressure regulator valve, alternator, injection pipes, fuel return hoses from injectors, exhaust manifolds, oil fill pipe, etc., must be provided with sufficient clearance for engine roll and torque.

(Section 6 – continued on next page)

(Section 6 – continued from previous page)

- When a vehicle is equipped with an electronic fuel injection (EFI) engine, it has an engine control module VCM. This VCM must be maintained at a temperature below 185°F at all times. This is most essential if the vehicle is put through a paint baking process. The VCM will become inoperative if its temperature exceeds 185°F. Therefore, it is recommended that temporary insulation be placed around the VCM during the time the vehicle is in a paint oven or undergoing another high temperature process.

Section 7 – Transmission

Models equipped with automatic transmissions have a transmission mounted neutral/park start safety mechanical lockout feature, which interfaces with the steering column ignition switch. Starter should operate only when gear shift lever is in neutral or park position. Readjust the shift linkage or switch if necessary as outlined in the Truck Service Manual.

Models equipped with brake-transmission shift interlock (BTSI) must fully apply the regular brakes before you can shift from park when the ignition key is in the run position.

Section 8 – Fuel and Exhaust

Fuel Systems

Due to the critical nature of sealing the fuel system, anyone making modifications or alterations to the existing system must assume complete responsibility for the system reliability, performance and compliance to FMVSS 301.

The fuel evaporative emission control equipment is certified to be in compliance with the Federal and California Vehicle Emission Standards. Any alterations to systems or components and their location could void compliance. System includes:

- Fuel tank, metering unit, fuel buffer module, lines including purge control solenoids, fuel vacuum sensor and canister(s).

For these reasons, **NO ALTERATION OF THE FUEL SYSTEM IS RECOMMENDED.**

Fuel Fill

Fuel tank filler pipe location should be so situated and constructed as to prevent gasoline vapor from emitting to vents of pilot flamed devices and to body and engine compartment air inlets.

(Section 8 – continued on next page)

(Section 8 – continued from previous page)

It is recommended that when mounting the fuel filler pipe assembly and vent hose that a minimum of 3.0 in. clearance be provided to any body component to prevent contact between hoses and/or mating parts and that retention be provided to ensure routing and prevent failure due to wear and fatigue. Filler pipe and vent line must have a gravity fuel flow to tank at all times; no fuel traps are allowed. Alterations of fuel line routings could affect the ability of the completed vehicle and are, therefore, not desirable. The complete fuel system must comply with FMVSS 301.

If additional new hose is required when installing fuel tank filler neck, this hose must be suitable for use with unleaded fuels or diesel fuel respectively.

Fuel Lines

Fuel line routing precautions:

- 12 in. minimum clearance to exhaust system is required or a metal shield must be provided.
- Use corrosion resistant steel tubing with short sections of approved hose to connect components. Hose-to-tube connections should be clamped for diesel systems. Steel tube ends should be beaded for hose retention. Fuel supply is pressurized by an in-tank pump for SCPI system. Coupled hose or nylon quick-connects must be used. Clamped hose is not acceptable for SCPI system.

All engines require a fuel return system which returns excess fuel from the injection pump and injector nozzles back to fuel tanks. Care should be taken that these lines are not blocked nor their hoses pinched. The engine may run poorly or stall if these lines are restricted or blocked.

All gasoline engine vehicles are equipped with fuel evaporative emission control equipment which is certified to be in compliance with the Federal or applicable California vehicle emission standards. Alterations to fuel tank and metering unit, fuel buffer module, lines, canister(s), fuel vacuum sensor, canister filters, canister purge control valves, relay switches, tank auxiliary vent valve, engine speed controller, or other devices/systems are therefore not allowable since vehicle adherence to C.A.R.B. and Federal regulations may be affected.

Fuel Tank

Tank may be pressurized to 0.7 PSI maximum to check for final line leakage or for forcing fuel through the system. Pressures greater than this amount may be detrimental and affect tank durability.

(Section 8 – continued on next page)

(Section 8 – continued from previous page)

The use of auxiliary fuel tanks is not recommended. If an auxiliary fuel tank is added, the alterer must take responsibility for compliance with affected motor vehicle safety standards. Also, if an auxiliary fuel tank is added to a gasoline-powered vehicle, the fuel must be drawn through a pipe at the top of the tank (balance line between tanks is not permitted).

Gasoline fueled vehicles are now equipped with a fuel pump return line. If an auxiliary tank is added, the tank selector valve must include a return port which returns fuel to the tank from which the fuel is being drawn.

In gasoline engines the fuel pump is located in the fuel tank. The battery must be disconnected before starting any work on the fuel system.

In the use of dual fuel systems, the vehicle operator should strictly adhere to the manufacturer's procedures for switching from gasoline to gaseous fuel operation. Improper switching procedures may result in overheating and damage to the exhaust system and the vehicle. The gaseous fuel tank should not be mounted in an enclosed area of the vehicle, such as the passenger compartment, trunk, etc., and the system should be vented to the outside of the vehicle. In addition, vehicles converted to gaseous fuels should not be stored in enclosed places such as garages. Further, General Motors cautions purchasers that the design, location and installation of any type of fuel storage system involves significant technical and engineering considerations and that these statements on gaseous fuel conversions should not be interpreted to be an approval by General Motors of any modification to the original equipment fuel system.

Conversions to gaseous fuel should be made in conformance with applicable Federal and State regulations. Removal of emission-control components or the addition of gaseous fuel systems, which could damage or reduce the longevity of those components, could cause the mechanical and emission performance warranty to be voided.

Exhaust System

Particular care should be taken to prevent the possibility of exhaust fumes and carbon monoxide exposure to vehicle occupants in units completed by body builders. Holes and openings through the floor and all other parts of the body must be permanently and adequately sealed by the body builder to avoid exhaust intrusion into any occupant area. If it is necessary to change the exhaust outlet location, the exhaust discharge must be unobstructed and directed away from occupant areas. Alteration of the exhaust outlet or its position may increase exhaust noise and render the vehicle illegal in those areas with pass-by noise regulations. All vehicles >10,000 lbs. GVWR come under Federal noise regulations, vehicles ≤10,000 lbs. GVWR are regulated by various state and local regulations of the Environmental Protection Agency; see those regulations for rules, test procedure and noise levels permitted.

Tail pipe outlet location must be tested statically and with the vehicle in motion to ensure that exhaust gases do not penetrate side or rear windows or underbody seams and holes. Auxiliary power plants should also be tested under the same conditions. Tail pipe exit ahead of rear wheels is not recommended.

(Section 8 – continued on next page)

(Section 8 – continued from previous page)

Check for leaks in exhaust systems and repair as required.

Exhaust temperatures can exceed 1600°F under extreme operating conditions, with pipe surface temperatures slightly less than this. Extreme care must be used when placing body components in the proximity of the exhaust system so as not to exceed the rated temperature limits of the components. Due to variants in underbody configurations of the vehicles, we are not in a position to make recommendations on how to insulate or design components in the proximity of the exhaust system.

Each manufacturer must make temperature checks of critical areas of his vehicle and adjust his design accordingly, or provide shielding to ensure safe operation of his body components.

The same can be said for the engine compartment. Obviously there will be additional heat radiated from the engine. How much is retained in the area will depend on how well this area is ventilated in your individual designs. Here again, temperature checks of interior areas surrounding the engine should be made to determine if your insulation is adequate. This is the same engineering practice we have followed on our complete vehicles incorporating these exhaust systems.

Exhaust system materials are selected and tested to withstand the operating environment of the vehicle. ***Do not modify the exhaust system in any way.*** The tail pipes are made of 409 aluminized stainless steel.

Heat shields are mounted to the underbody and/or exhaust system components (catalytic converter and muffler). Shields for the propshaft hanger bearings are also provided in some vehicles.

Section 9 – Steering

Check power steering fluid level and system operations. (Refer to Owner's Manual).

Steering wheel and horn pad must not be altered or replaced.

The steering column mast jacket must not be altered.

Section 10 – Tires

Check wheel lug nuts for proper torque; specifications are provided in the Owner's Manual.

(Section 10 – continued on next page)

(Section 10 – continued from previous page)

Substitution of tires of greater capacity than those offered as original equipment by vehicle manufacturer is not approved for use on original equipment wheels. Any usage of higher capacity tires must be accompanied by higher capacity wheels. However, the wheel offset and distance from centerline of rim to wheel mounting face must be the same as the replaced original equipment wheel to ensure proper wheel bearing loading and clearance of tires to body and chassis components.

Increasing tire and wheel capacity does not necessarily increase vehicle GVW ratings.

It is recommended that tire chain clearance guideline J683, from the Society of Automotive Engineers, be adhered to in designing rear wheelhouse clearance.

Check tires and inflate to recommended tire pressure according to the tire pressure information provided in the Owner's Manual and the tire inflation label provided with the vehicle.

Any substitution of tires may affect Speedometer/Odometer accuracy.

Section 12 – Electrical Battery and Battery Cables

The vehicle battery should be located and positioned to make use of the existing battery cables. If the battery requires relocation and longer cables are required, a proportionately larger gauge wire must be used. If, in relocating the battery, the negative ground cable is attached to the frame rail, a cable of similar gauge must be provided between the frame rail and the engine. This is required due to the heavy electrical loads imposed by the starting circuit. To ensure proper operation of the battery cables, the following chart on length, gauge and materials must be strictly adhered to:

| Combined Length of Positive and Negative | |
|--|--------------------------|
| Cable Gauge | Cable in Inches (Copper) |
| 4 | 1 - 66 |
| 2 | 67 - 107 |
| 0 | 108 - 170 |

If the battery is remotely mounted (other than in the engine compartment), the 'Sense' circuit in the generator regulator shall be used. The sense circuit consists of a 7.76 OHM 1/4 watt resistor connected in series between the 'S' terminal of the generator and the B+ terminal of the battery.

(Section 12 – continued on next page)

(Section 12 – continued from previous page)

Modifications/add-on wiring must be carefully reviewed to ensure compatibility with the base vehicle wiring by reviewing system schematics, wire routing paths, harness connections, etc. Due to the wide range of modifications that may be required for vocational needs, it is not feasible for the O.E.M. to take into account all potential revisions. For this reason, any person modifying existing vehicle wiring must assume responsibility that the revisions have not degraded the electrical system performance.

Any add-on wiring must be properly fused and routed to prevent cut, pinch, and chafe problems, as well as avoid exposure to excessive heat. Care must be exercised that existing vehicle interfaces do not have their current load capabilities exceeded and the respective control devices are not overloaded. Added wire size should be at least as large as the wire to which it is attaching in order for fuse protection to be maintained.

A Packard Electric wiring repair kit is available through Kent-Moore (GM P/N 12085264, Kent-Moore P/N J38125-4). This kit contains instructions, tools and components for making repairs to wiring harness components. This kit would also greatly assist in accomplishing necessary add-on wiring, such as body marker lamps, so that system reliability/durability is maintained.

Electrical wiring components can be obtained through your authorized GM dealer. Many Packard Electric components are also available through Pioneer Standard Company (1-800-PACKARD). Pioneer may also be able to assist in making necessary wiring additions by providing custom wiring studs or jumpers to your specifications.

Fusible Link Repair Procedure:

1. Cut damaged fusible link from wiring harness assembly splice.
2. Strip insulation from harness wire as required to splice on new fusible link.
3. Fabricate a new fusible link wire approximately 6 to 8 in. long from the same wire size as the original link. (Acceptable fusible link material will be imprinted with the wire size and the wording to identify it as fusible link. Fusible link cable is not the same as normal vehicle wiring.)
4. Terminate fusible link harness wire with a suitable compression splice clip, and solder with an electrical grade rosin core solder. Wrap splice area with double-wall heat shrink tape to provide electrical insulation, as well as mechanical strain relief at the splice. Standard plastic electrical tape does not provide suitable protection on the under hood and exterior regions of the vehicle.
5. Strip, terminate, solder, and insulate remaining end of fusible link with appropriate termination to be compatible with the rest of the electrical system.
6. For further information, refer to the instruction manual in the wiring repair kit referenced elsewhere in this section.

(Section 12 – continued on next page)

(Section 12 – continued from previous page)

Accessory Power Supply Feeds

For power requirements to service additional devices to be added by body builder/upfitter, the power supply source must be at the power distribution center on the driver's side of the vehicle.

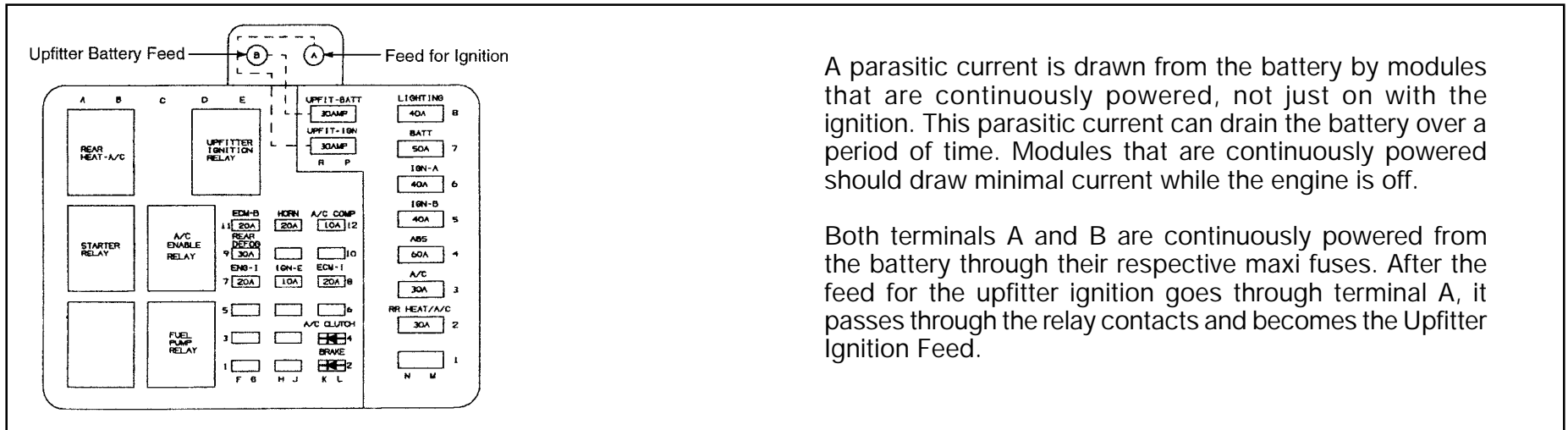

A parasitic current is drawn from the battery by modules that are continuously powered, not just on with the ignition. This parasitic current can drain the battery over a period of time. Modules that are continuously powered should draw minimal current while the engine is off.

Both terminals A and B are continuously powered from the battery through their respective maxi fuses. After the feed for the upfitter ignition goes through terminal A, it passes through the relay contacts and becomes the Upfitter Ignition Feed.

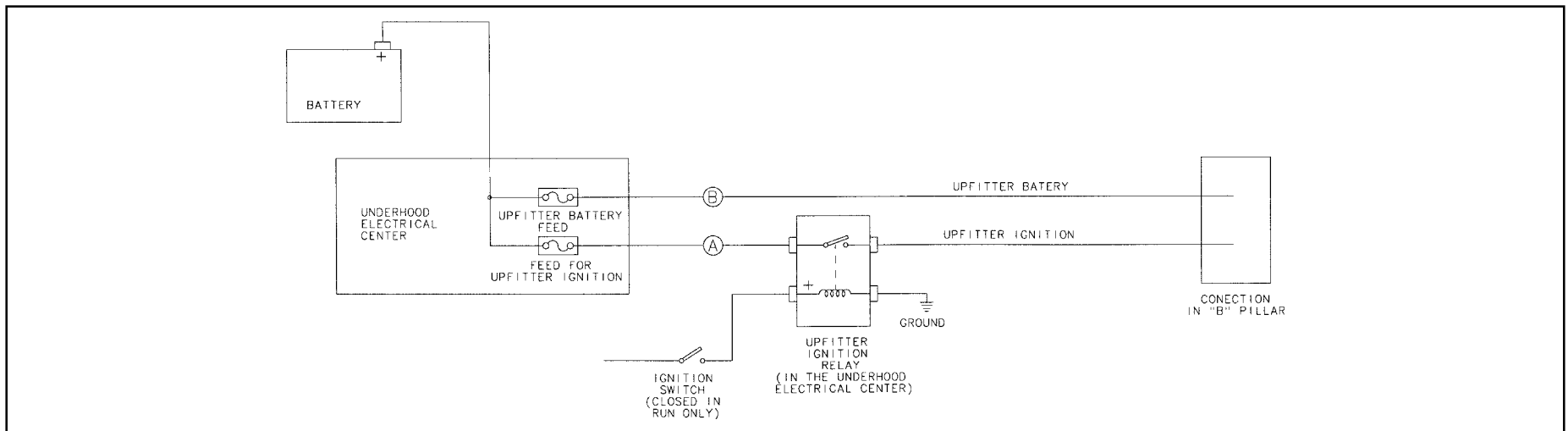

Section 13 – Heating/Cooling

To provide satisfactory engine cooling, the following conditions must be met:

1. Do not locate any large objects in front of the radiator core or grille such as batteries, spare tires, lights/sirens, etc. They restrict air flow into the radiator core and influence fan blade stress.
2. Grille opening, size configuration and the external baffles provided should not be altered in any manner. Any reduction in cooling ability may adversely affect engine/transmission performance.
3. Fan clutches not conforming to the original equipment specifications may not operate correctly and may stay “on” continuously, never come on, or cycle on and off excessively. This will result in a reduction of fuel economy, engine overheat at times, and annoying cycling respectively.
4. Continuous coolant flow is necessary from heater connection on engine-to-heater connection on radiator to control transmission oil temperatures during closed thermostat (warm-up) operation. Do not alter this flow as it may result in premature engine or transmission failure.
5. If a heater unit is not installed in the vehicle or a heater shut-off valve is required, a line connecting the heater connection on the engine to the heater connection on the radiator must be installed. When a shut-off valve is required in heating system, it must be teed into the system in such a manner as to maintain continuous flow between engine heater connection – radiator heater connection at all times.
6. Use GM Long Life Coolant only.

Do not install any internal flow restrictors.

- Heater hose: 3-way or 4-way valves must be used to provide constant water flow through the intake manifold pad area.
- If in-line shut-off valve is used in combination with 3-way valves, shut-off valve must not be closed until 3-way valve at engine is in the proper position.

| Valve Sources | | |
|---------------|-----------------------------------|----------------|
| 3-Way | Red-White Valve Corp., Carson, CA | (213) 549-1010 |
| | Ranco Controls Div., Delaware, OH | (614) 876-8022 |
| 4-Way | Ranco Controls Div., Delaware, OH | (614) 876-8022 |

Be sure to add coolant to system after adding capacity to system (heaters).

M/L 11005 General Arrangement, Exterior

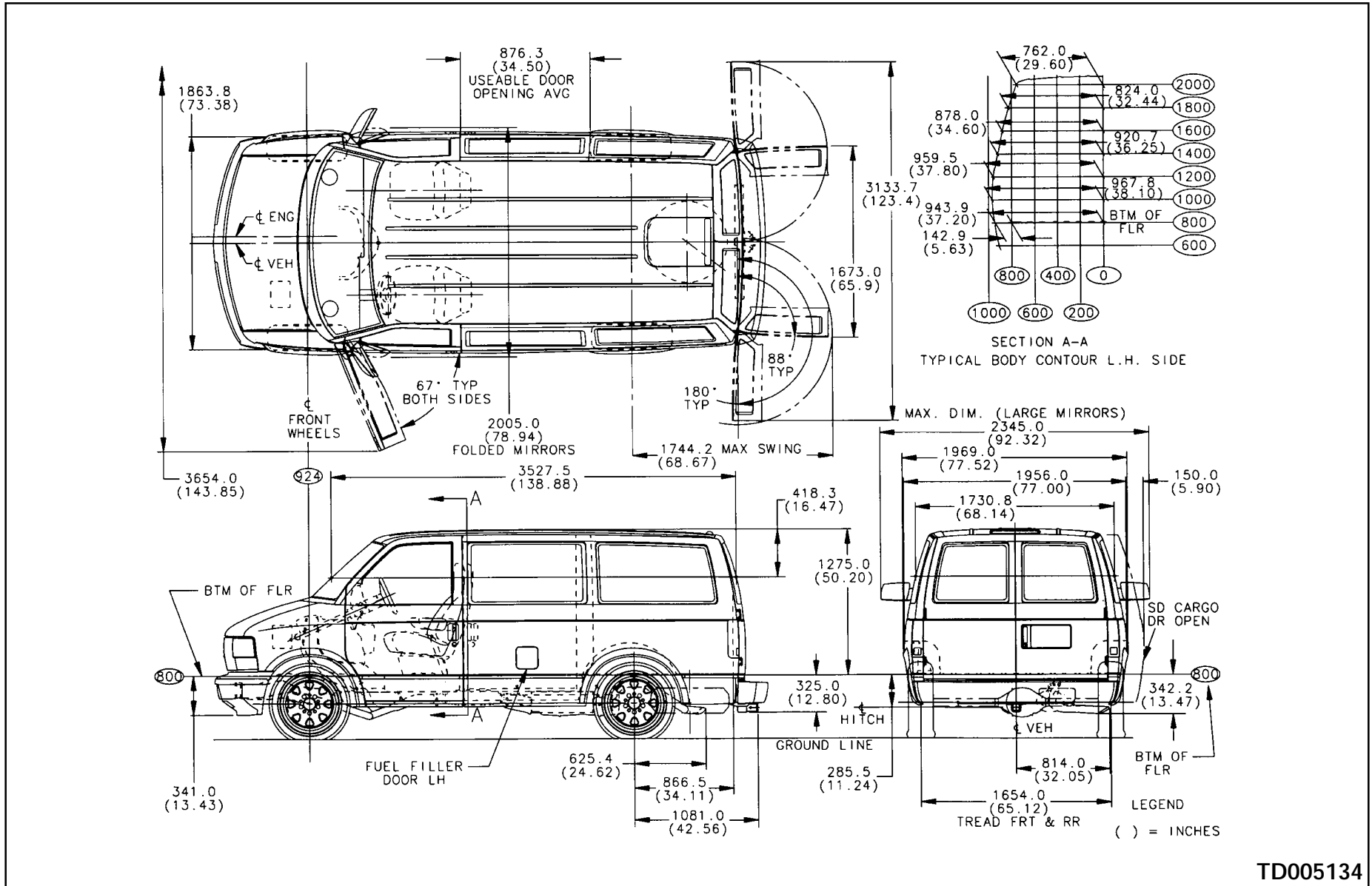

TD005134

M/L 11006 General Arrangement, Exterior

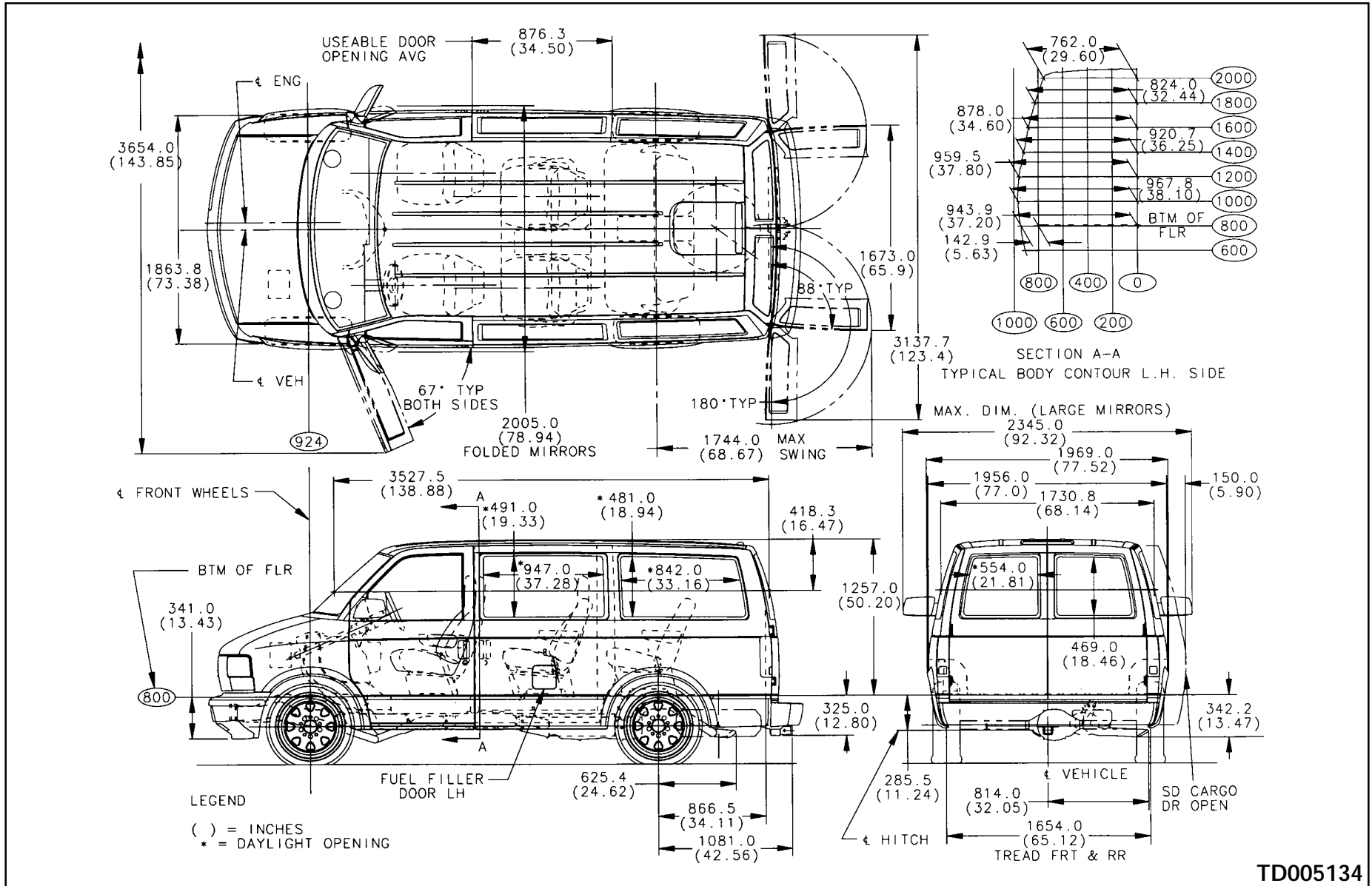

TD005134

M/L 110(05, 06) General Arrangement, Interior

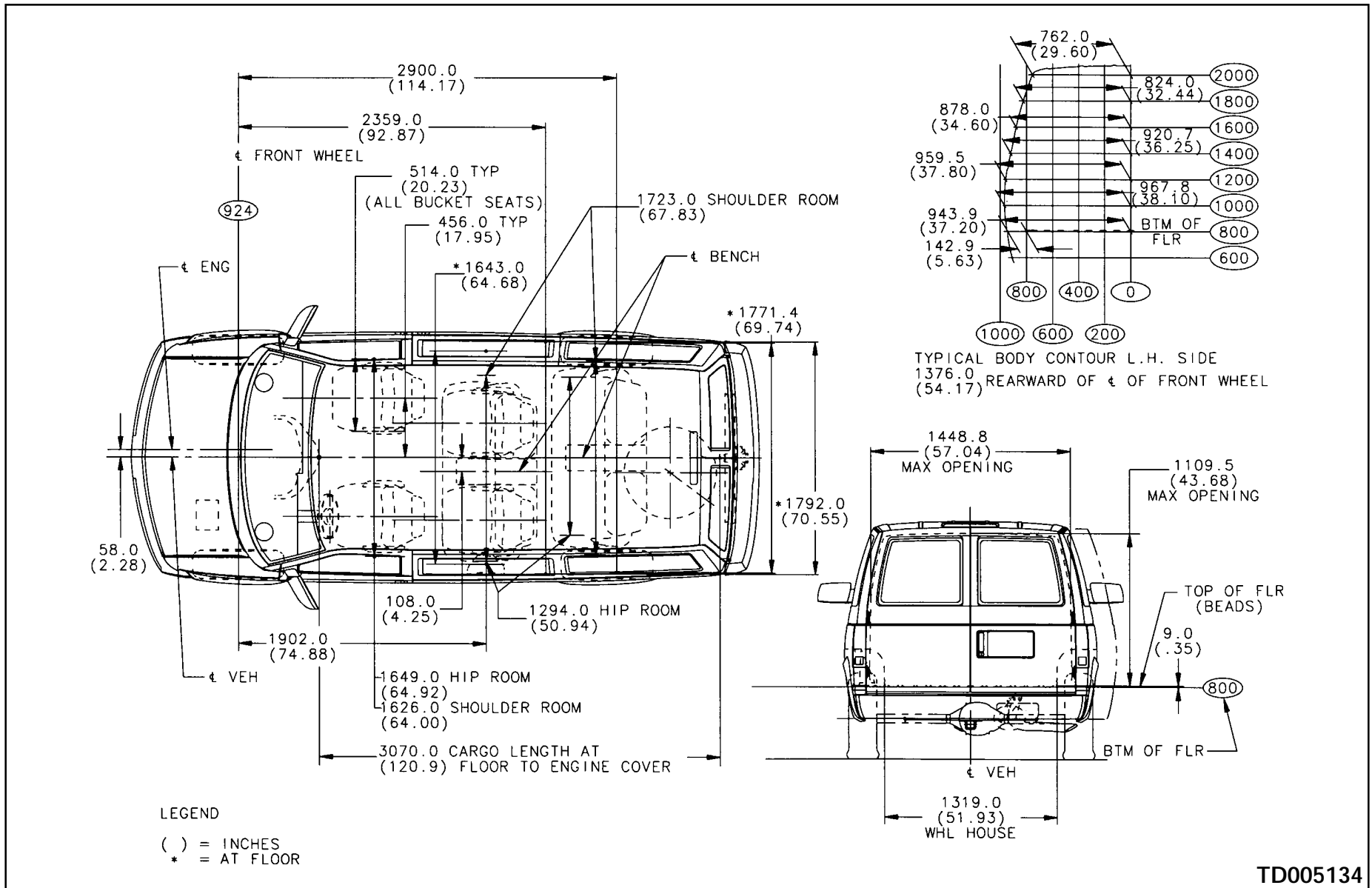

TD005134

M/L 110(05, 06) General Arrangement, Interior

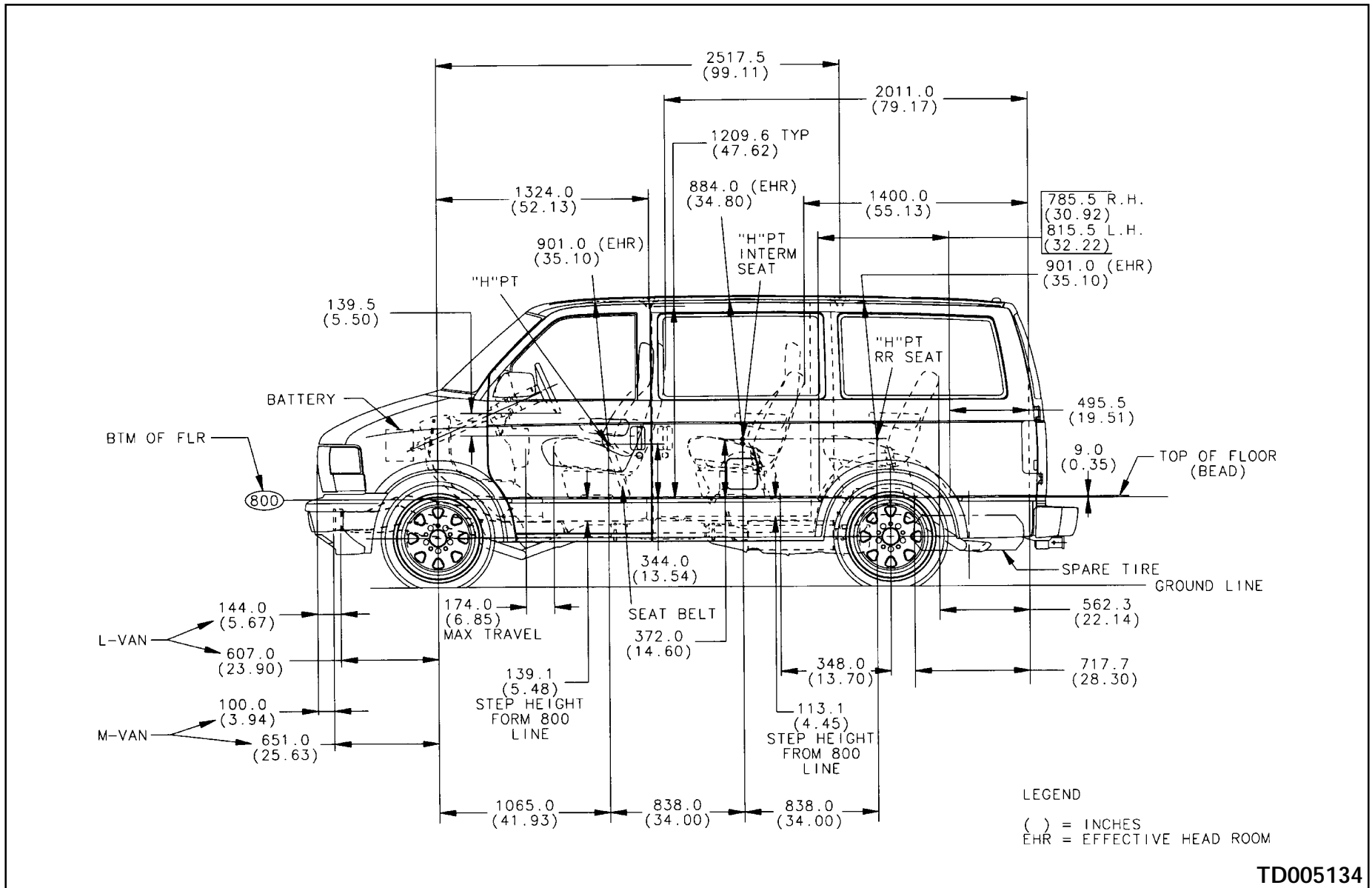

TD005134

M/L 110(05, 06F) Bumper, Tailgate and Dutch Door

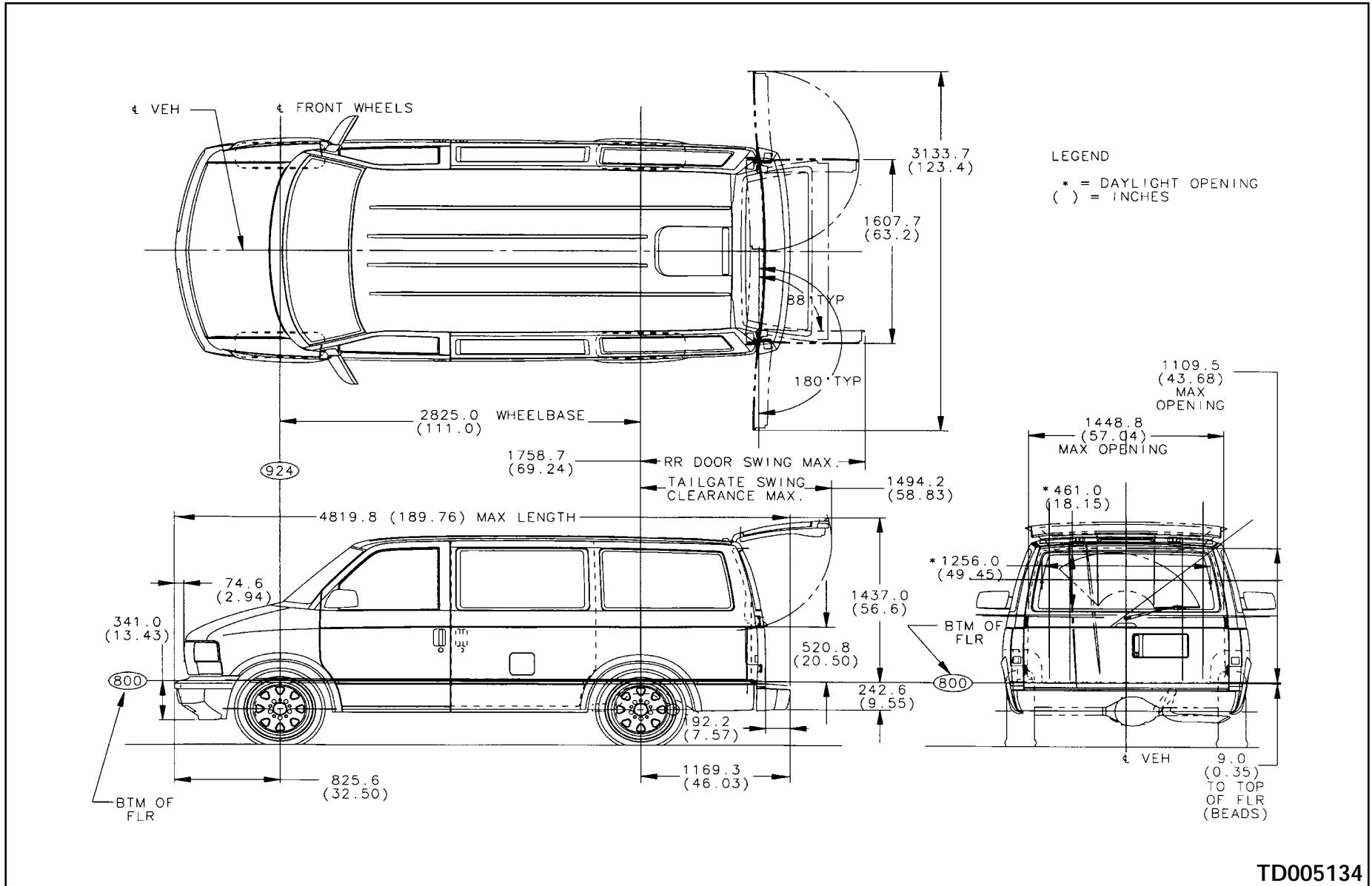

TD005134

M/L 110(05, 06) Seat Mounting Hole Locations

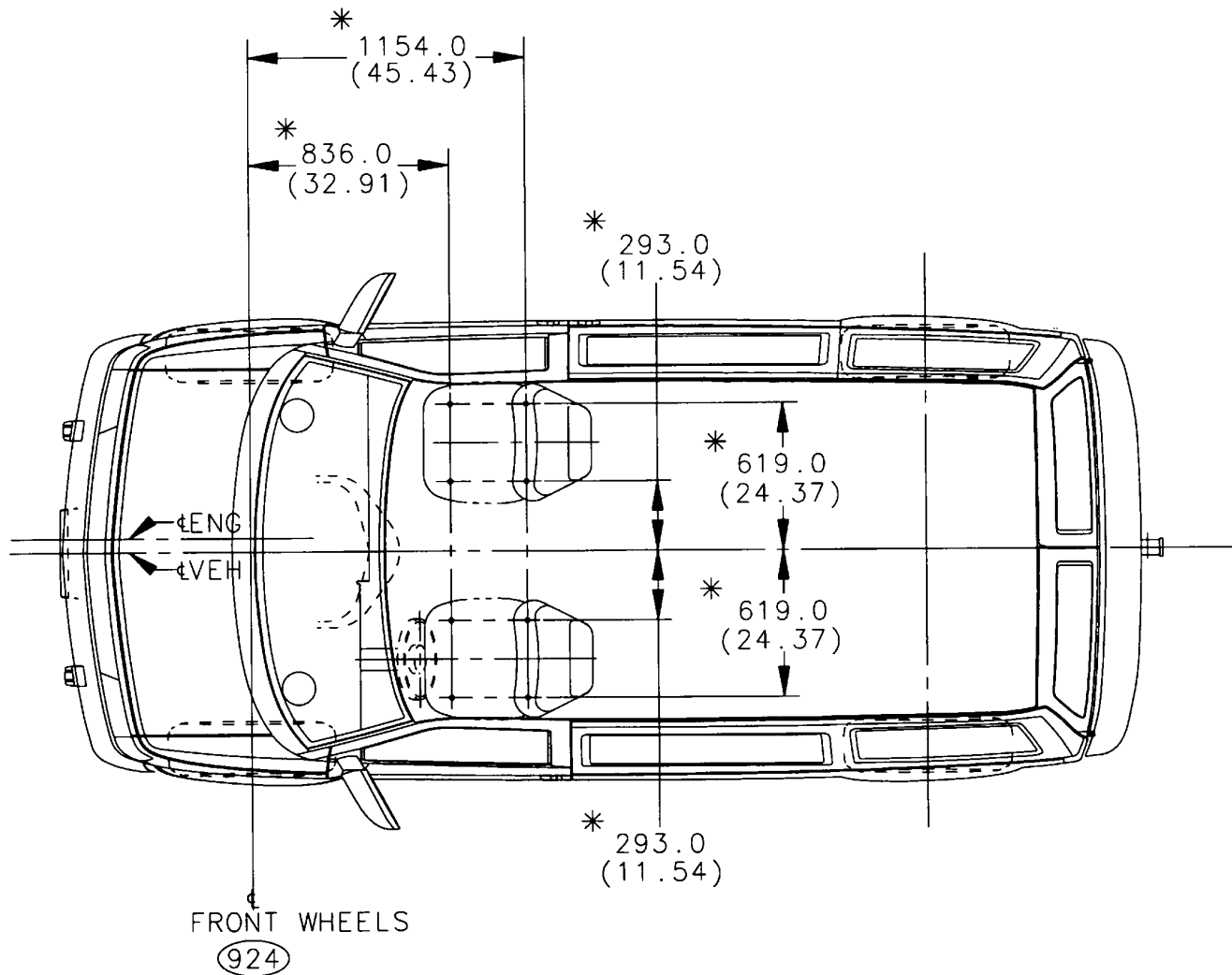

* DIMENSIONS SHOW BOLT PATTERN FOR FRONT SEAT RISERS

TD005134

M/L 110(05, 06) Roof Rack Mounting

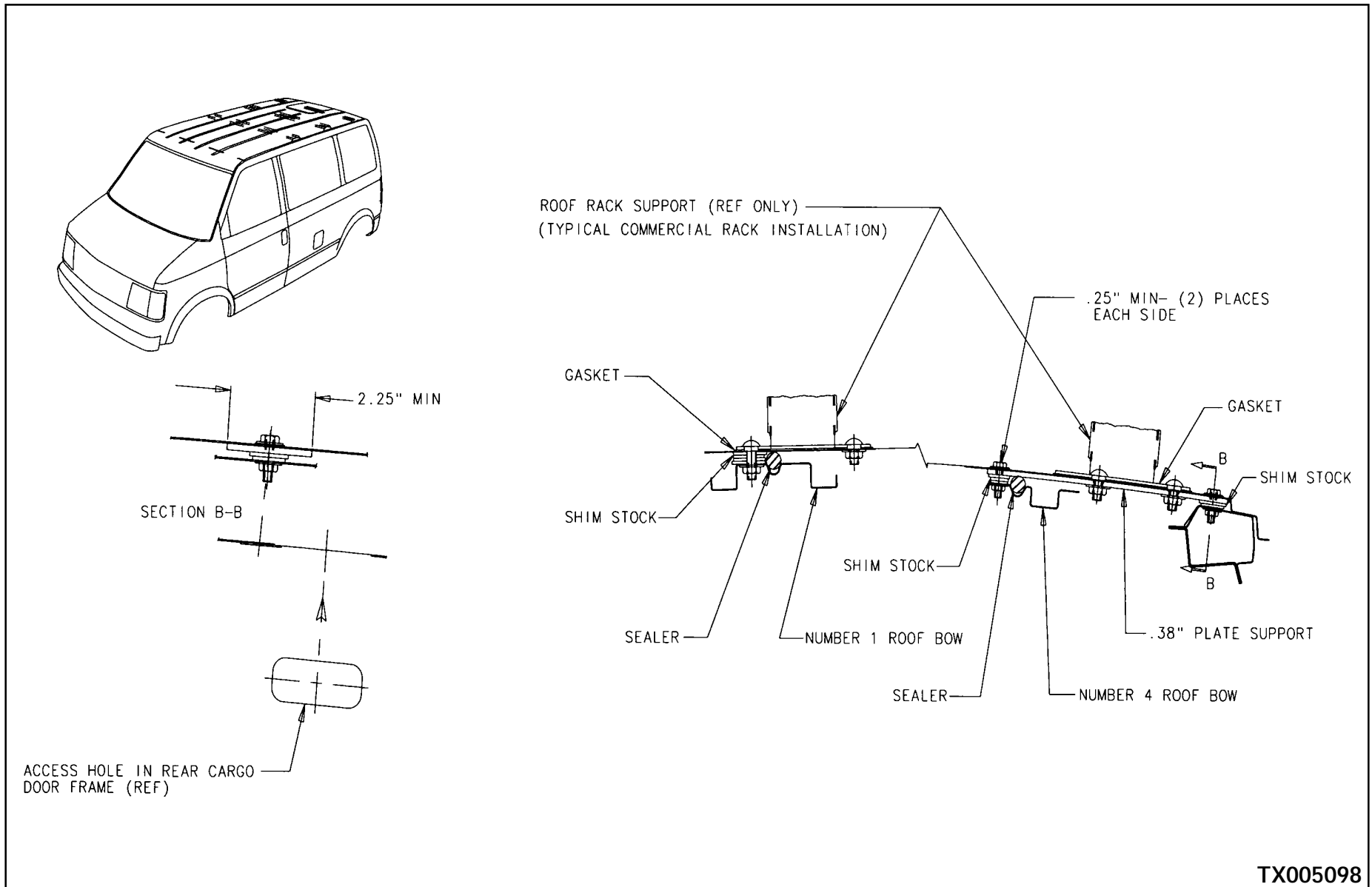

TX005098

Ordering Information

Electrical diagrams are available from Chevrolet and GMC through service publications. They have contracted the following companies to handle the ordering and shipping of the manuals.

Helm Inc.
P.O. Box 07130
Detroit, Michigan 48207

1 (313) 865-5000 for information and inquiries
1 (800) 782-4356 for credit card orders

Routine orders will be shipped within 10 days of receipt. Rush orders will be accommodated for an additional charge.

Order forms are available upon request and orders can be paid by check or money order, made payable to the mentioned companies. Credit Card orders can be made by phone on the listed toll free phone numbers.