

SPECIAL APPLICATIONS

TRUCK-CAMPER LOADING	TC— 1
SNOWPLOW PREP PACKAGE (VYU)	SP— 1
Ballast Compensating Weight	SP— 2
2004 Chevrolet/GMC Snowplow Prep Package – Option VYU, Pickup – K15703-K25943	SP— 3
2004 Chevrolet/GMC Snowplow Prep Package – Option VYU, Pickup – K25953-K35943	SP— 5
2004 Chevrolet/GMC Snowplow Prep Package – Option VYU, Cab Chassis/Utility	SP— 7
Allowable Center of Gravity Calculation	SP— 9
2004 Allowable Center of Gravity Charts	SP— 10
Snowplow Prep Package (VYU) Electrical Provisions	SP— 12
Figure 1 (Instrument Panel)	SP— 13
Figure 2 (Emergency Vehicle Roof Lamp Harness to Roof Header)	SP— 14
Figure 3 (Accessory Harness Grommet)	SP— 15
Figure 4 (Forward Lamp Harness In-Line Connectors – L.H.)	SP— 16
Figure 5 (Forward Lamp Harness In-Line Connectors – R.H.)	SP— 17
Front Exterior Lamp Connector Circuit Function Charts	SP— 18
Forward Lamp Harness In-Line Connectors	SP— 20
Headlamp Connectors	SP— 21
Front Exterior Lamp Electrical Connector Part Numbers	SP— 22
Figure 6 (Basic Trailer Wiring Package)	SP— 23
Figure 7 (Heavy Duty Trailer Wiring Package)	SP— 24
PICKUP BOX REMOVAL PROGRAM	PB— 1
Alterations to Complete Vehicles	PB— 1
Federal Motor Vehicle Safety Standards	PB— 3
FMVSS 101 – Controls and Displays	PB— 3

SPECIAL APPLICATIONS

PICKUP BOX REMOVAL PROGRAM – *Continued*

FMVSS 102 – Transmission Shift Lever Sequence, Starter Interlock and Transmission Braking Effect	PB— 4
FMVSS 103 – Windshield Defrosting and Defogging Systems	PB— 4
FMVSS 104 – Windshield Wiping and Washing Systems	PB— 5
FMVSS 105 – Hydraulic Service Brake, Emergency and Parking Brake Services	PB— 5
Allowable Center of Gravity Calculation	PB— 6
2004 Allowable Center of Gravity Charts	PB— 7
FMVSS 106 – Brake Hoses	PB— 10
FMVSS 108 – Lamps, Reflective Devices and Associated Equipment	PB— 10
FMVSS 111 – Rearview Mirrors	PB— 11
FMVSS 112 – Headlamp Concealment Devices	PB— 12
FMVSS 113 – Hood Latch System	PB— 12
FMVSS 114 – Theft Protection (<i>GVWR of 10,000 Pounds or Less</i>)	PB— 12
U.S. CFR 49, PART 565/CMVSS 115 – Vehicle Identification Number	PB— 13
FMVSS 116 – Motor Vehicle Brake Fluids	PB— 13
FMVSS 120 – Tire Selection and Rims for Vehicles Other than Passenger Cars	PB— 13
FMVSS 124 – Accelerator Control Systems	PB— 14
FMVSS 201 – Occupant Protection in Interior Impacts (<i>GVWR of 10,000 Pounds or Less</i>)	PB— 14
FMVSS 202 – Head Restraints (<i>GVWR of 10,000 Pounds or Less</i>)	PB— 15
FMVSS 203 – Impact Protection for the Driver from the Steering Control System (<i>GVWR of 10,000 Pounds or Less</i>) .	PB— 15
FMVSS 204 – Steering Control Rearward Displacement (<i>GVWR of 10,000 Pounds or Less</i>)	PB— 15
FMVSS 205 – Glazing Materials	PB— 15
FMVSS 206 – Door Locks and Door Retention Components (Not Applicable to Bus)	PB— 16
FMVSS 207 – Seating Systems	PB— 16
FMVSS 208 – Occupant Crash Protection	PB— 17
FMVSS 209 – Seat Belt Assemblies	PB— 19

SPECIAL APPLICATIONS

PICKUP BOX REMOVAL PROGRAM – *Continued*

FMVSS 210 – Seat Belt Assembly Anchorages.....	PB– 19
FMVSS 212 – Windshield Mounting (<i>GVWR of 10,000 Pounds or Less</i>).....	PB– 20
FMVSS 214 – Side Impact Protection (<i>GVWR of 10,000 Pounds or Less – Static</i>) (<i>GVWR of 6,000 Pounds or Less – Dynamic</i>).....	PB– 21
FMVSS 216 – Roof Crush Resistance (<i>GVWR of 6,000 Pounds or Less</i>).....	PB– 21
FMVSS 219 – Windshield Zone Intrusion (<i>GVWR of 10,000 Pounds or Less</i>).....	PB– 21
FMVSS 301 – Fuel System Integrity MPV’S, Trucks and Buses (<i>GVWR of 10,000 Pounds or Less</i>)	PB– 22
2004 C/K Pickup Box Removal Program – TABLE A	PB– 23
FMVSS 302 – Flammability of Interior Materials	PB– 26
Canada Motor Vehicle Safety Standards	PB– 26
Statements Regarding Canada Motor Vehicle Safety Standards	PB– 27
CMVSS 108 – Lighting Equipment (Daytime Running Lamps)	PB– 27
Radio Noise Interference	PB– 28
U.S. EPA and California Exhaust and Evaporative Emission Requirements and NHTSA Fuel Economy Regulations.	PB– 28
Pickup Box Removal Fuel Fill System Modifications for Gasoline Vehicles	PB– 31
Fuel Tank Filler Neck (Gas – 15113986)	PB– 32
Fuel Tank Filler Neck (Diesel) – 15008137 (Diesel 2003 & 2004 Start of Production thru December) 15113971 (Diesel 2004I [interim] – January 2004)	PB– 33
Fuel Filler Pipe Assembly to Frame – Chassis Cab (ZW9) Trucks	PB– 34
Fuel Filler Pipe Assembly to Frame – Pickups Without (ZW9)	PB– 35
Fuel Filler Pipe Assembly to Frame – Rear Axle Vent Hose (ZW9)	PB– 36
Fuel Filler Pipe Assembly to Frame – Rear Axle Vent Hose (ZW9)	PB– 37
Pickup Box Removal Tail Lamp Wiring Modifications	PB– 38
Rear Junction Block.....	PB– 38
Rear Tail Lamps and License Plate Lamp.....	PB– 38
Combination Lamps on All New C/K Chassis	PB– 39

SPECIAL APPLICATIONS

PICKUP BOX REMOVAL PROGRAM – *Continued*

Rear Chassis Wiring Harness and Rear Lamp Connector Faces	PB— 39
Rear Junction Block as Viewed from Rear of Vehicle with ZW9	PB—40
Rear Junction Block Electrical Diagram	PB— 41
Rear Junction Block and Bracket Installation – Chassis Cab (ZW9) Trucks	PB— 42
Left Hand Tail Lamp to Frame – Chassis Cab (ZW9) Trucks	PB— 43
Left Hand Tail Lamp and License Plate Lamp to Junction Block – Chassis Cab (ZW9) Trucks	PB— 44
Right Hand Tail Lamp to Frame – Chassis Cab (ZW9) Trucks	PB— 45
Right Tail Lamp Harness to Junction Block – Chassis Cab (ZW9) Trucks	PB— 46
Basic Trailer Wiring Package	PB— 47
Heavy Duty Trailer Wiring Package (If Equipped)	PB— 48
Trailer Wiring Stop/Turn Circuit Electrical Diagram	PB— 49
Rear Junction Block – Rear Chassis Harness Connector	PB— 50
Rear Junction Block – Left Hand Tail Lamp Connector	PB— 51
Rear Junction Block – Right Hand Tail Lamp Connector	PB— 52
Rear Junction Block – License Plate Lamp Connector	PB— 53
Rear Bumper Removal Wiring Modifications	PB— 54
License Plate Lamp to Rear Junction Block – Pickup with Rear Bumper Delete (VF7)	PB— 55

TRAILERING INFORMATION	TR— 1
How to use GCWRs to Determine Powertrain and Rear Axle Ratio for Trailering	TR— 1
Gross Combination Weight Ratings (GCWR)	TR— 1
S/T Utility (GMT305) Models (GMC Envoy XUV)	TR— 1
S/T Pickup (GMT 355) Models (Chevy Colorado and GMC Canyon)	TR— 1
S/T Pickups and Utilities (GMT 325/330) Models (Chevy S10/Blazer and GMC Sonoma/Jimmy)	TR— 2

SPECIAL APPLICATIONS

TRAILERING INFORMATION – Gross Combination Weight Ratings (GCWR) – *Continued*

S Pickup (GMT368) Model (Chevy SSR)	TR— 2
S/T Utility (GMT360) Models (Chevy TrailBlazer and GMC Envoy)	TR— 2
S/T Utility (GMT370) Models (Chevy TrailBlazer EXT and GMC Envoy XL)	TR— 2
C/K 15/25/25HD/35/36 Series Pickup and Cab-Chassis Models (Chevy Silverado and GMC Sierra)	TR— 3
C/K Utility Models (Chevy Tahoe/Suburban and GMC Yukon/Yukon XL)	TR— 3
C/K Luxury Utility Models (Cadillac Escalade and GMC Denali)	TR— 4
C/K Ultimate Utility Models (Cadillac Escalade EXT and Chevy Avalanche)	TR— 4
H2 Utility Models (Hummer)	TR— 4
M/L Van Models (Chevy Astro and GMC Safari)	TR— 4
G/H Van (GMT610) Models (Chevy Express and GMC Savana)	TR— 5
2003 Maximum Trailer Ratings	TR— 6
Weight Carrying Hitch and Weight Carrying Distribution Hitch and Sway Control	TR— 6
S/T (GMT325) Pickup Models (Chevy S10 and GMC Sonoma)	TR— 6
S/T (GMT330) Utility Models (Chevy Blazer)	TR— 7
S/T (GMT355) Pickup Models (Chevy Colorado and GMC Canyon)	TR— 8
S/T (GMT305) XUV Models (GMC Envoy XUV)	TR— 9
S/T (GMT360) Utility Models (Chevy TrailBlazer and GMC Envoy)	TR— 10
S/T (GMT370) Utility Models (Chevy TrailBlazer EXT and GMC Envoy XL)	TR— 11
S/T (GMT368) Pickup Models (Chevy SSR)	TR— 12
C/K 15/25 Series Light Duty Pickup Models (Manual Transmission) (Chevy Silverado and GMC Sierra)	TR— 13
C 15/25 Series Light Duty Pickup Models (Automatic Transmission) (Chevy Silverado and GMC Sierra)	TR— 14
K 15/25 Series Light Duty Pickup Models (Automatic Transmission) (Chevy Silverado and GMC Sierra)	TR— 15
C/K 25 Series Heavy Duty Pickup Models (Chevy Silverado and GMC Sierra)	TR— 17
C/K 35 Series Heavy Duty Pickup Models (Chevy Silverado and GMC Sierra)	TR— 18
C/K Utility Models (Chevy Tahoe/Suburban and GMC Yukon/Yukon XL)	TR— 19

TRAILERING INFORMATION – 2003 Maximum Trailer Ratings – *Continued*

C/K Luxury Utility Models (Cadillac Escalade/Escalade ESV and GMC Yukon Denali/Yukon XL Denali)	TR— 20
C/K Ultimate Utility Models (Cadillac Escalade EXT and Chevy Avalanche)	TR— 21
H2 Utility Models (Hummer)	TR— 22
M/L Van Models (Chevy Astro and GMC Safari)	TR— 23
G/H Van (GMT610) Models (Chevy Express and GMC Savana)	TR— 24
C/K 25 Series Dedicated CNG or CNG/Gas Bi-Fuel Pickup Models (Chevy Silverado and GMC Sierra).....	TR— 26
G/H Dedicated CNG or CNG/Gas Bi-Fuel Van Models (Chevy Express and GMC Savana)	TR— 27
5th Wheel or Gooseneck Trailer Ratings	TR— 28
C 15/25 Series Light Duty Pickup Models (Chevy Silverado and GMC Sierra)	TR— 28
K 15/25 Series Light Duty Pickup Models (Chevy Silverado and GMC Sierra).....	TR— 29
C/K 25 Series Heavy Duty Pickup Models (Chevy Silverado and GMC Sierra)	TR— 30
C/K 35 Series Heavy Duty Pickup Models (Chevy Silverado and GMC Sierra)	TR— 31
TRAILERING ELECTRICAL INFORMATION	TR— 32
Trailer Harness Release	TR— 32
Trailer Harness Wire Colors	TR— 32
Vehicle to Trailer Electrical System Setup.....	TR— 33

2004 MODEL YEAR GENERAL MOTORS CORPORATION

INFORMATION REGARDING

CONSUMER INFORMATION TRUCK-CAMPER LOADING

PUBLISHED MARCH 2003



CHEVROLET MOTOR DIVISION
100 RENAISSANCE CENTER
DETROIT, MICHIGAN 48265-1000

GMC

GMC DIVISION
100 RENAISSANCE CENTER
DETROIT, MICHIGAN 48265-1000

2004 MODEL YEAR GENERAL MOTORS TRUCKS

CONSUMER INFORMATION TRUCK-CAMPER LOADING

Consumer Information Regulation 575.103 issued by the National Highway Traffic Safety Administration requires manufacturers of trucks capable of accommodating slide-in camper bodies to provide information concerning proper load and proper load distribution in truck-camper applications.

This Consumer Information booklet is designed to provide basic information relating to load capabilities of 2004 Model Year General Motors truck models which are adaptable to slide-in camper applications. Information contained herein is applicable to the truck buyer who already owns a 2004 Model Year General Motors truck or to a prospective truck purchaser.

The regulation also provides that proper truck-camper loading information is to be maintained in truck dealerships and be made available to all prospects on request. This booklet relates to the 2004 Model Year General Motors truck models recommended for slide-in camper applications and is to be used as a consumer information brochure.

Product specifications or data contained herein may change periodically. When a revision of this booklet is supplied to truck dealers, it is the dealers' responsibility to make the revised information available to the public.

Chevrolet and GMC's 1500-3500 Series (Silverado/Sierra) Full-Size Pickups feature were redesigned beginning with the 1999 Model Year. Some aftermarket products may not fit in the bed of your new vehicle, such as:

- Products manufactured for 1988-2000 Model Year C/K 10/20/30 series pickups.
- Products manufactured for R/V models built prior to the 1992 Model Year

Please check the compatibility of any aftermarket product you intend to install on your new 2004 Model Year vehicle with your aftermarket product manufacturer.

All illustrations and specifications contained in this publication are based on the latest product information available at the time of publication. We reserve the right to discontinue or change at any time, without notice, any colors, optional equipment, specification and/or body types.

TRUCK-CAMPER LOADING

Consumer Information Regulation 575.103 requires manufacturers of trucks capable of accommodating slide-in campers to specify the vehicles' Cargo Weight Rating (CWR) and the longitudinal limits within which the center of gravity for the Cargo Weight Rating should be located.

Cargo Weight Rating (CWR) – means the value specified by the vehicle manufacturer as the cargo-carrying capacity of a vehicle in kilograms (pounds), exclusive of (minus) the weight of occupants, computed as 68 kilograms (150 pounds) times the number of designated seating positions.

Longitudinal Center of Gravity (CG) Zone for CWR – The forward limit of the recommended CG Zone is determined by the application of dimension "A" measured in centimeters (inches) from the rear of the truck bed. The rearward limit of the recommended CG Zone is established by application of dimension "B", also measured in centimeters (inches) from the rear of the truck bed. The recommended CG Zone lies between these points.

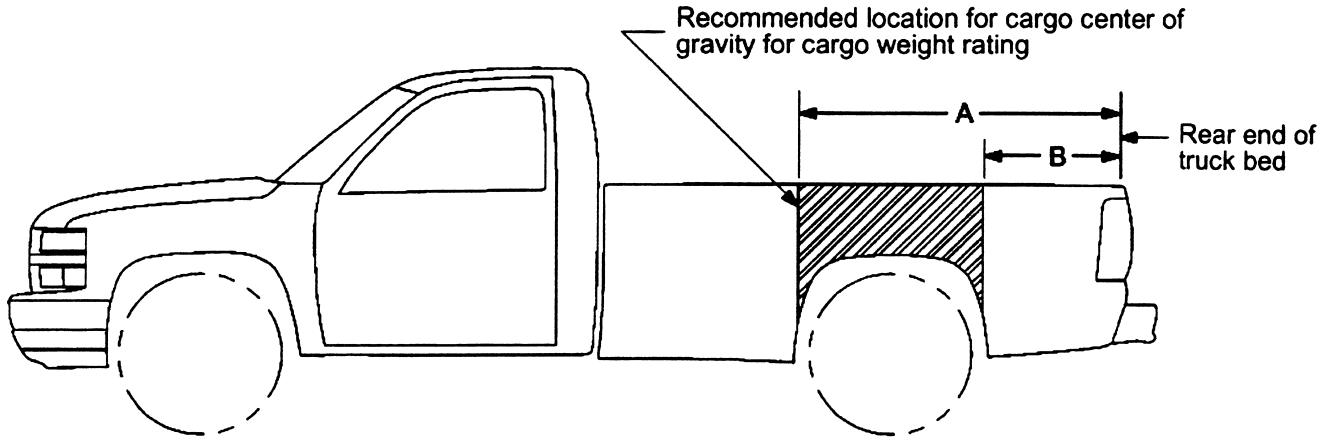

Model _____ Calculated Cargo Weight Rating _____
 Dimension A _____ Dimension B _____

LIMITATIONS ON RECOMMENDED CG ZONES

FORWARD LIMIT

- Must not extend beyond the inside surface of the pickup box.
- Must not exceed the front gross axle rating (GAWR).

REARWARD LIMIT

- Must be no farther rearward than the inside surface of the pickup box.
- Must not exceed the gross axle weight rating (GAWR) of the rear axle.
- Must not exceed rear axle load limits below:

Series	Rear Axle Load Limits (% of total vehicle weight)
Silverado/Sierra	
1500 (regular/extended cab)	56%
2500 (crew cab)	70%
2500 (extended cab)	70%
2500HD (regular, extended & crew cab)	66%
3500 (regular, extended & crew cab)	75%

Vehicle CG Identification – All General Motors Corporation trucks that may be suitable for carrying a slide-in camper incorporate a Truck-Camper Loading information label located on the glove box floor for Silverado/Sierra models. The vehicle identification number (VIN) and the as-manufactured Cargo Weight Rating (CWR) of that vehicle plus the CG limits of dimension "A" and "B" for that vehicle in centimeters (inches) are included.

Vehicle and Truck-Camper Loading are also discussed at length in the Vehicle Owner's Manual.

TRUCK-CAMPER LOADING

Loading Instructions – When the truck is used to carry a slide-in camper, the total cargo load of the truck consists of the manufacturer's camper weight figure, the weight of installed additional camper equipment not included in the manufacturer's camper weight figure, the weight of camper cargo and the weight of passengers *in the camper*. The total cargo load should not exceed the truck's Cargo Weight Rating (CWR) and the camper's center of gravity should fall within the truck's recommended center of gravity zone when installed.

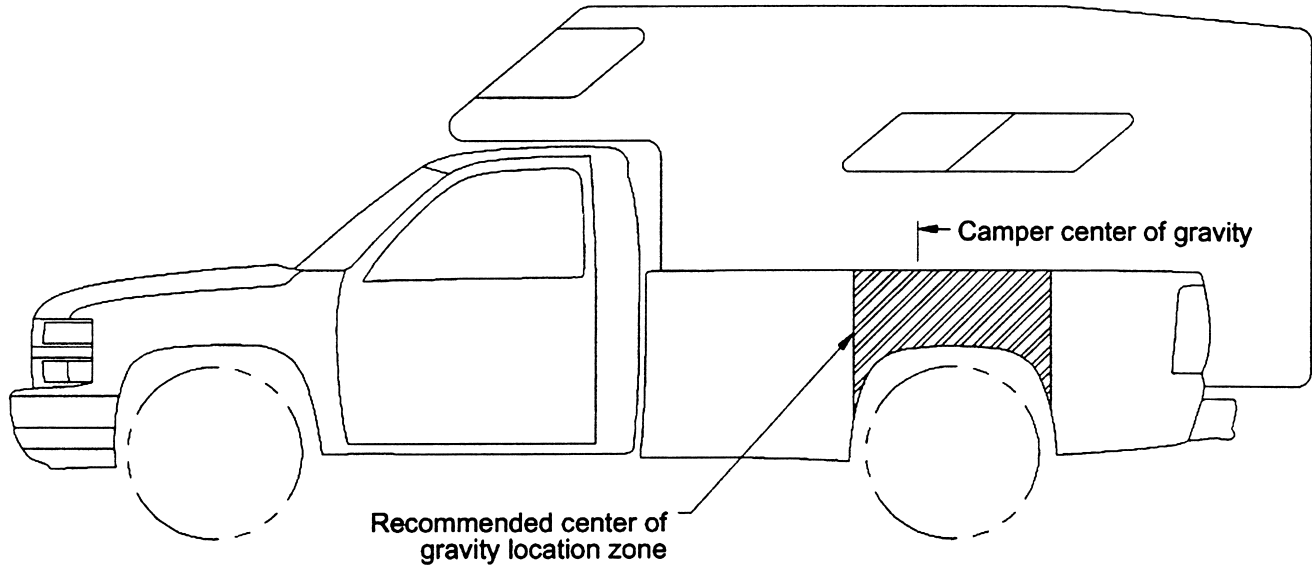

Any accessories or other equipment added to this vehicle, after final date of manufacture, must be weighed or have their weight determined, and the weight deducted from the prescribed Cargo Weight Rating (CWR) of this vehicle. This may decrease the permissible longitudinal zone of the center of gravity for this vehicle.

The longitudinal center of gravity zone has been determined for the full Cargo Weight Rating of this truck. If a slide-in camper has a total weight less than the Cargo Weight Rating (CWR), the permissible longitudinal zone of the center of gravity may be larger. However, individual axle loads should not exceed either of the gross axle weight ratings (GAWR).

Secure loose items to prevent weight shifts that could affect the balance of your vehicle. When the truck-camper is loaded, drive to a scale and weigh on the front and on the rear wheels separately to determine the axle loads. Individual axle loads should not exceed either of the gross axle weight ratings (GAWR). The total of the axle loads should not exceed the gross vehicle weight rating (GVWR). These ratings are given on the vehicle certification label that is located on the left side of the vehicle, normally on the door latch post or door edge next to the driver. If weight ratings are exceeded, move or remove items to bring all weights below the ratings.

CAUTION:

The longitudinal center of gravity is only one of the many factors that may affect the overall performance of a vehicle, including handling, steering and braking. The cargo load should be distributed on both sides of the centerline as equally as possible. The recommended longitudinal limits for the camper's center of gravity are based on the assumption that the vehicle will be operated with reasonable prudence in light of all of the existing conditions. Failure to do so could result in unsatisfactory vehicle performance and could make the vehicle unsafe to operate.

In this connection, refer to any recommendations by the slide-in camper manufacturer regarding installation and loading of the camper.

TRUCK-CAMPER LOADING

DEFINITION OF TERMS

For the purposes of calculating Truck-Camper Loading in this book, listed below are some common terms and abbreviations:

Cargo Weight Rating (CWR) – means the value specified by the vehicle manufacturer as the cargo-carrying capacity of a vehicle in kilograms (pounds), exclusive of (minus) the weight of occupants, computed as 68 kilograms (150 pounds) times the number of designated seating positions.

Center of Gravity (CG) – point where the mass of a body is concentrated and if suspended at that point would balance front and rear.

Curb Weight – weight of a vehicle without driver, passengers or cargo but including maximum capacity of fuel, oil, coolant and other items of standard equipment.

Dimension A & B – front and rear limit of Center of Gravity (CG) zone.

Gross Vehicle Weight Rating (GVWR) – means the value specified by the manufacturer as the loaded weight of a single vehicle.

Gross Axle Weight Rating (GAWR) – means the value specified by the vehicle manufacturer as the load-carrying capacity of a single axle system measured at the tire-ground interfaces.

Model Weight – weight of the vehicle with all items of standard equipment, 68 kilograms (150 pounds) per passenger in each designated seating position and maximum capacity of fuel, oil and coolant.

Payload Rating – maximum allowable load (including the weight of the driver and all occupants) that the vehicle can carry based on all factory-installed equipment on the vehicle.

RPO – Regular Production Option.

Slide-in Camper – means a camper having a roof, floor, and sides, designed to be mounted on and removable from the cargo area of a truck by the user.

Weight Distribution – the amount of a vehicle's weight that rests on each axle.

Wheelbase (WB) – the distance from the centerline of the front axle to the centerline of the rear axle.

LIMITATIONS

The following General Motors truck models are not recommended for slide-in camper applications:

- Any pickup model with a Cargo Weight Rating (CWR) of less than 226.8 kg (500 lbs). A statement to this effect is imprinted on the Truck-Camper Loading information label that states whether that vehicle is recommended for use with a slide-in camper.
- S/T S-10/Sonoma pickups,
- S/T Colorado/Canyon pickups,
- SSR pickup,
- C/K Avalanche or Escalade EXT pickups,
- H2 Sport Utility Truck.

Note: Silverado/Sierra 1500 Pickups should not be used for larger, cab-over type slide-in campers.

TRUCK-CAMPER LOADING

C/K, REGULAR, EXTENDED AND CREW CAB PICKUPS

INSTRUCTIONS FOR PROSPECTIVE TRUCK PURCHASERS

VEHICLE SELECTION AND WEIGHT ANALYSIS

Silverado/Sierra Models

From the GM Dealer World Website or GM Autobook model selection pages, select the Silverado/Sierra Pickup you desire. Record this information on page 3. Refer to the Specification section for the selected model. Select the GVWR you require and note any minimum tire size and chassis equipment requirements for that GVWR. (To approximate the GVWR you require, add your loaded camper weight to the vehicle curb weight plus the occupants' weight at 68 kg (150 lbs) per designated seating position.) Record the GVWR and the Gross Axle Weight Rating (GAWR) front and rear (from the Specifications section), on line 1 of the camper loading worksheet, page 7.

Record the front and rear curb weights of your selected vehicle on line 2, page 7.

Record the front and rear passenger weights on line 3, page 7.

List all factory-installed options you desire, including any options required by your selected GVWR, with their front and rear weights on the Pickup Camper Loading Worksheet on page 7.

Total the front and rear weights of the vehicle model and options to arrive at the total front and rear weight of the vehicle. Follow the directions on page 7, lines 5 through 5C to arrive at the adjusted total vehicle weight.

Subtract the adjusted total vehicle weight from the GVWR to arrive at the Cargo Weight Rating (CWR)* of your truck. Record this information on page 3.

Proceed to page 11 and calculate the center of gravity location limits using front and rear GAWRs, Cargo Weight Rating (CWR), and front and rear weight of truck as determined above. Record this information on page 3.

* The addition of any dealer installed or other accessories will reduce the cargo-carrying capacity by the weight of the equipment installed.

TRUCK-CAMPER LOADING

C/K PICKUPS

WORKSHEET – CARGO WEIGHT RATING

1. Model GVWR _____ GAWR Front _____ Rear _____

2. Curb Weights: Front _____ Rear _____

3. Passenger Weights: Front _____ Rear _____

Other factory-installed options:

..... Front _____ Rear _____
 Front _____ Rear _____
 Front _____ Rear _____
 Front _____ Rear _____
 Front _____ Rear _____
 Front _____ Rear _____
 Front _____ Rear _____
 Front _____ Rear _____
 Front _____ Rear _____
 Front _____ Rear _____

4. TOTALS Front _____ Rear _____

Front and Rear Weights:

Front _____ Rear _____

5a. Vehicle sub-total weight (add front and rear weight)

5b. Add 22.7 kg (50 lbs) for all models*

+22.7 kg (50 lbs)

5c. Adjusted total vehicle weight:

Vehicle GVWR: _____

Adjusted total vehicle weight (- _____)

Cargo Weight Rating _____

Record on Page 3.

*If your vehicle is available, drive to a scale and weigh, with occupants, full fuel tank, and other factory-installed options to determine the adjusted total vehicle weight. You will then be able to use your actual total vehicle weight and not have to add the 22.7 kg (50 lbs).

TRUCK-CAMPER LOADING

C/K SERIES PICKUP

FLEETSIDE/WIDESIDE

Short Box (Models Silverado/Sierra 15703, 15753, 25743, 25753)

Long Box (Models Silverado/Sierra 15903, 15953, 25903, 25953, 35903, 35943, 35953)

OPTION E63	A	B	C	D	E	F	G	H	J	K	L	
Short Box	Centimeters	157.2	127.3	198.9	49.6	107.3	212.0	162.1	199.8	157.2	–	202.5
	(Inches)	(61.9")	(50.1")	(78.3")	(19.5")	(42.2")	(83.5")	(63.8")	(78.7")	(61.9")	–	(79.7")
Long Box	Centimeters	157.4	127.3	198.9	49.6	107.3	260.0	162.0	247.8	157.4	244.1	202.5
	(Inches)	(62.0")	(50.1")	(78.3")	(19.5")	(42.2")	(102.4")	(63.8")	(97.7")	(62.0")	(96.1")	(79.7")

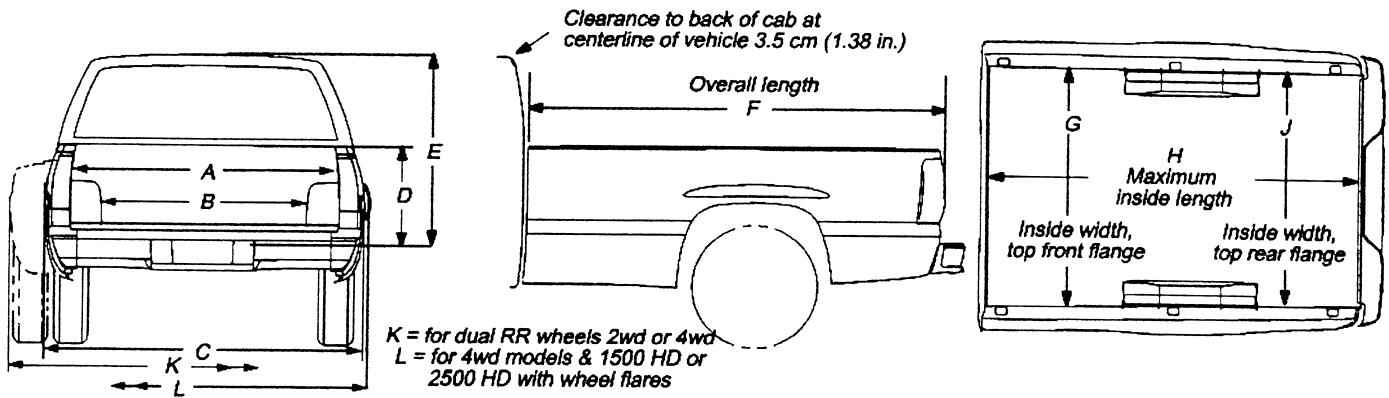

SPORTSIDE

Short Box (Model Silverado/Sierra 15703, 15753)

OPTION E62	A	B	C	D	E	F	G	H	J	
Short Box	Centimeters	130.0	131.2	199.4	49.9	107.3	211.3	124.6	199.7	124.6
	(Inches)	(51.1")	(51.7")	(78.5")	(19.6")	(42.2")	(83.2")	(49.1")	(78.6")	(49.1")

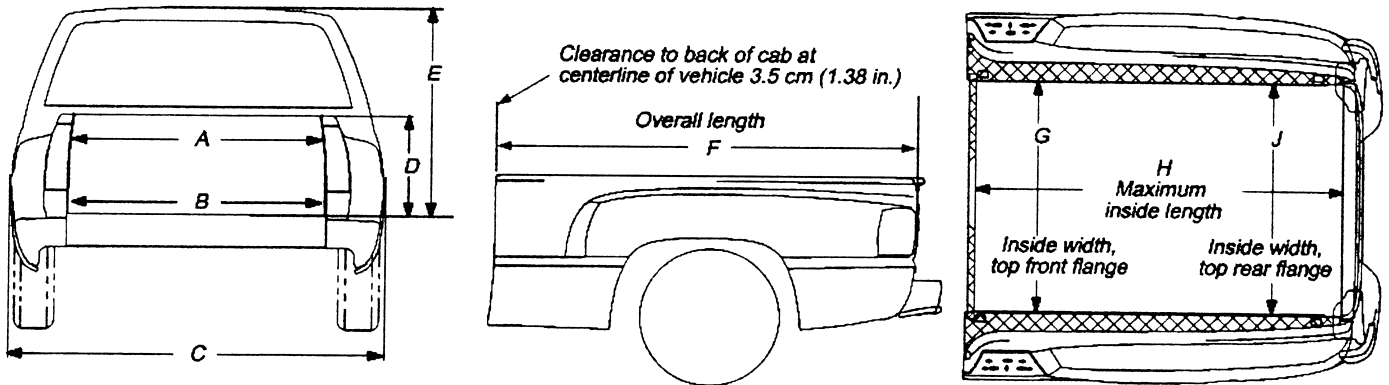

TRUCK-CAMPER LOADING

MODEL CODES AND DIMENSIONS

REGULAR CAB MODELS

SERIES	MODEL NUMBER	PICKUP BOX LENGTH cm (ft)	PICKUP STYLE	WB cm (in)	"C"* cm (in)
Silverado/ Sierra 1500	C/K 15703	197.6 (6.5')	Fleetside/Wideside (E63) Sportside (E62)	302.3 (119.0")	98.8 (38.9")
	C/K 15903	245.6 (8.0')	Fleetside/Wideside (E63)	337.8 (133.0")	111.3 (43.8")
Silverado/ Sierra 2500	C/K 25903	245.6 (8.0')	Fleetside/Wideside (E63)	337.8 (133.0")	111.3 (43.8")
Silverado/ Sierra 3500	C/K 35903	245.6 (8.0')	Dually Fleetside/Wideside (E63)	337.8 (133.0")	111.3 (43.8")

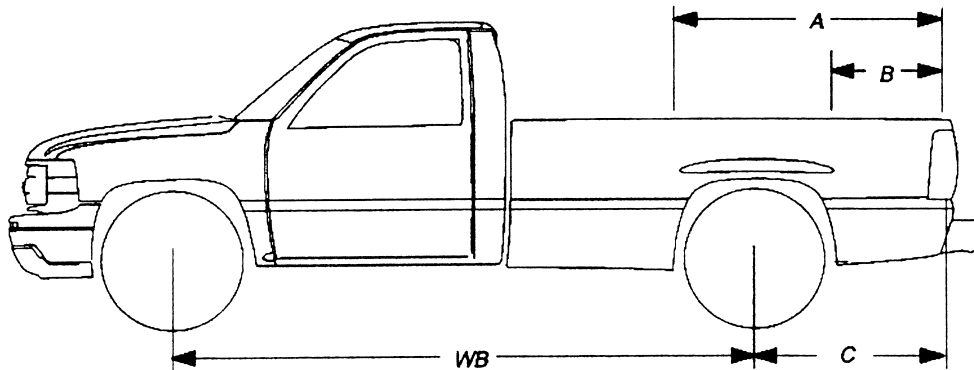

EXTENDED CAB MODELS

SERIES	MODEL NUMBER	PICKUP BOX LENGTH cm (ft)	PICKUP STYLE	WB cm (in)	"C"* cm (in)
Silverado/ Sierra 1500	C/K 15753	197.6 (6.5')	Fleetside/Wideside (E63) Sportside (E62)	364.5 (143.5")	98.8 (38.9")
	C/K 15953	245.6 (8.0')	Fleetside/Wideside (E63)	400.0 (157.5")	111.3 (43.8")
Silverado/ Sierra 2500	C/K 25753	197.6 (6.5')	Fleetside/Wideside (E63)	364.5 (143.5")	98.8 (38.9")
	C/K 25953	245.6 (8.0')	Fleetside/Wideside (E63)	400.0 (157.5")	111.3 (43.8")
Silverado/ Sierra 3500	C/K 35953	245.6 (8.0')	Dually Fleetside/Wideside (E63)	400.0 (157.5")	111.3 (43.8")

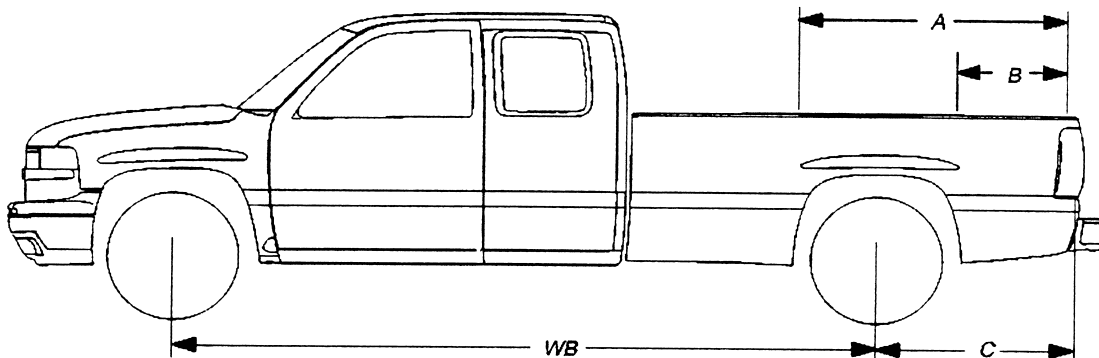

TRUCK-CAMPER LOADING

MODEL CODES AND DIMENSIONS

CREW CAB MODELS

SERIES	MODEL NUMBER	PICKUP BOX LENGTH cm (ft)	PICKUP STYLE	WB cm (in)	"C" ^{**} cm (in)
Silverado/ Sierra 2500	C/K 25743	198.1 (6.5')	Fleetside/Wideside (E63)	388.6 (153.0")	98.8 (38.9")
	C/K 25943	243.8 (8.0')	Fleetside/Wideside (E63)	424.2 (167.0")	111.3 (43.8")
Silverado/ Sierra 2500	C/K 35943	243.8 (8.0')	Dually Fleetside/Wideside (E63)	424.2 (167.0")	111.3 (43.8")

* Dimensions "C" is the distance from the centerline of the rear axle to the end of the pickup box floor.
Dimension A and B can be calculated by using formula on page 11.

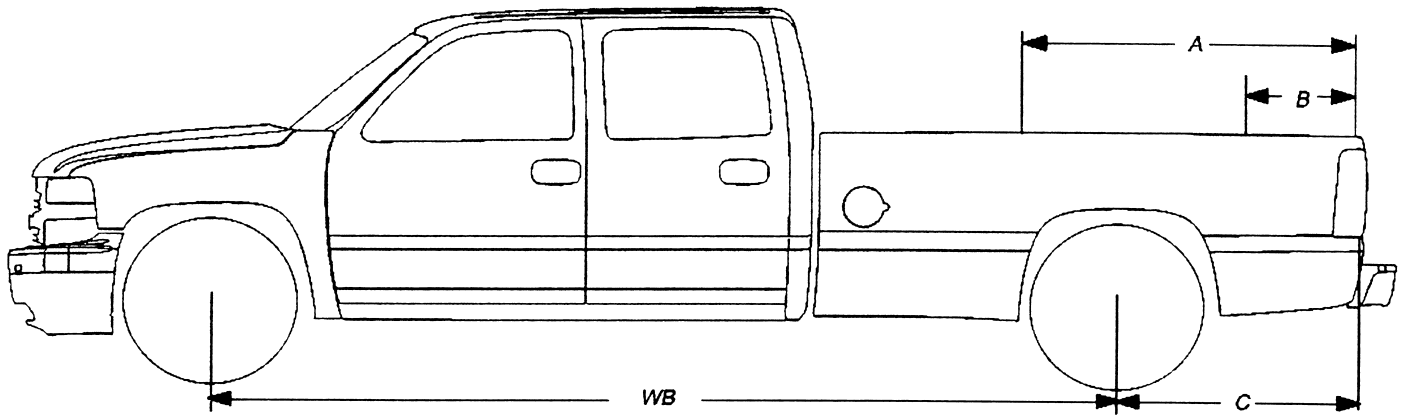

TRUCK-CAMPER LOADING

CALCULATIONS TO DETERMINE FORWARD (A) AND REARWARD (B) LOCATION OF CENTER OF GRAVITY FOR CARGO WEIGHT RATING

Calculations for Dimension A

$$A = \frac{\{\text{Front GAWR} - (1.05 \times \text{Front Weight}^* \text{ of Truck})\} \times \text{WB} + \text{C}}{\text{Cargo Weight Rating}}$$

Enter Front GAWR.....			
Subtract Front Weight* of Truck x 1.05.....	-		
Answer.....			
Divide Answer by Cargo Weight Rating (CWR)	÷		
Answer.....			
Multiply Answer by Wheelbase (See Charts on page 9 or 10)	X		
Answer.....			
Add C Dimension to Answer (See Charts on page 9 or 10)	+C		
Dimension A in centimeters (in inches)	=		

Note: If "A" is greater than pickup box length, use box length for "A" dimension.

Calculations for Dimension B

$$B = \frac{\{1 - \frac{\text{Rear GAWR} - (1.1 \times \text{Front Weight}^* \text{ of Truck})}{\text{Cargo Weight Rating}}\} \times \text{WB} + \text{C}}$$

Enter Rear GAWR.....			
Subtract Rear Weight* of Truck x 1.1	-		
Answer.....			
Divide Answer by Cargo Weight Rating (CWR).....	÷		
Answer.....			
Subtract Answer from 1.000.....	-		
Multiply Answer by Wheelbase (See Charts on page 9 or 10)	X		
Answer.....			
Add C Dimension to Answer (See Charts on page 9 or 10)	+C		
Dimension B in centimeters (in inches)	=		

Note: If "B" dimension is negative, use 0 (zero) for "B" dimension. If "B" dimension is greater than "A" dimension, camper usage is not recommended at the Calculated Cargo Weight Rating. Camper usage may be possible for a lighter camper. Substitute known specific camper weight (less than Cargo Weight Rating) for Cargo Weight Rating in calculations above to determine "A" to "B" range for that specific camper.

Record dimension A and B on page 3.

*From page 7 line 4.



CHEVROLET MOTOR DIVISION
100 RENAISSANCE CENTER
DETROIT, MICHIGAN 48265

GMC

PONTIAC • GMC DIVISION
100 RENAISSANCE CENTER P.O. BOX 431301
DETROIT, MICHIGAN 48243-7301

SNOWPLOW PREP PACKAGE (VYU)

The chart on the following page shows GMTG approved models available with snowplow prep package-option VYU.

General Motors recommends that when a snowplow is mounted on a vehicle, only one passenger should accompany the driver. More than one passenger may exceed Front Gross Axle Weight Ratings.

Prior to installing a front mounted snowplow, the following process should be followed and necessary information obtained.

- Establish vehicle curb weight
- Establish chassis manufacturer's front and rear axle weight ratings
- Chevrolet and GMC truck dealers can provide availability, specifications, Gross Vehicle Weight Ratings (GVWR), and Front and Rear Gross Axle Weight Ratings (FGAWR/RGAWR). For vehicles already built, this information can be found on the certification label installed on driver's door/door frame or provided on the cover of the Incomplete Vehicle Document.

The following information should be obtained and provided by the manufacturers of snowplows and salt spreaders:

- Specifications, weights and center of gravity data
- Vehicle installation guidelines and instructions
- Calculation of weight distribution for the front and rear axles

The loaded vehicle with driver, passenger, aftermarket accessories, snowplows, spreader, and cargo must not exceed the Gross Vehicle Weight Rating (GVWR), and Front and Rear Gross Axle Weight Ratings. In addition, the completed curb weight vehicle, with all installed aftermarket accessories, snowplow, and spreader, and with 400 lbs. distributed in the driver-passenger area of the vehicle, must have a center of gravity location that is located within the trapezoid formed by the coordinates A, B, C, D, H1 & H2, plus it must be to the rear of vertical line E and forward of vertical line F as defined in the ALLOWABLE CENTER OF GRAVITY CHARTS. If the center of gravity location does not fall within the specified trapezoid, ballast weight may be required to shift the center of gravity location until it falls within the specified trapezoid.

The snowplow manufacturer and the installer of the aftermarket equipment should determine the amount of rear ballast required to ensure that the vehicle, with the attached snowplow and aftermarket equipment, complies with the Allowable Center of Gravity Trapezoid and the resulting front and rear weight distribution ratio as defined in the Allowable Center of Gravity Charts published in this manual.

(Snowplow Prep Package – continued on next page)

SNOWPLOW – ONLY ON THE C/K, UTILITY AND CAB CHASSIS

(Snowplow Prep Package – continued from previous page)

Ballast Compensating Weight

The use of rear ballast weight may be required to prevent exceeding the Gross Axle Weight Rating of the front axle. The use of rear ballast weight may be required to ensure that the center of gravity location of the completed vehicle, with the attached snowplow and other installed equipment, complies with the Allowable Center of Gravity Trapezoid and the resulting front and rear weight distribution ratio, even though the actual front weight may be less than the Gross Axle Weight Rating of the front axle. In either case, the rear ballast weight should be securely attached in the cargo box or behind the rear axle of the vehicle in a manner which prevents it from moving during driving and stopping.



To help avoid personal injury, refer to Z-height setting procedure before adjusting torsion bars. If torsion bars are adjusted for aftermarket equipment, be sure to return them to specification when the equipment is removed. Otherwise, a front shock absorber may dislodge and damage a front brake line. This could result in an accident when minimum stopping distances are required.

SPECIAL APPLICATIONS

2004 Chevrolet/GMC Snowplow Prep Package – Option VYU, Pickup – K15703-K25943

Model		K15703	K15903	K25753	K25753 HD	K25743	K25903	K25943
Cab		Regular	Regular	Extended	Extended	Crew	Regular	Crew
Wheelbase Inches		119	133	143.5	143.5	153	133	167
P.U. Box Length feet		6.5	8	6.5	6.5	6.5	8	8
GVWR lb. (option code)		6100(C5M)	6400(C7H)	8600(C6P)	9200(C6W)	9200(C6W)	9200(C6W)	9200(C6W)
GAWR lb. – Frt.		3925	3925	4500	4800	4800	4800	4800
Engine Availability with VYU:	Opt. Code							
Vortec 8.1L Gasoline V8 Engine	L18	N/A	N/A	N/A	A	N/A	A	N/A
Duramax 6.6L Diesel V8 Engine	LB7	N/A	N/A	N/A	A	N/A	A	N/A
Vortec 4800 V8 Gasoline	LR4	A	A	N/A	N/A	N/A	N/A	N/A
Vortec 5300 V8 Gasoline	LM7	A	A	N/A	N/A	N/A	N/A	N/A
Vortec 6000 V8 Gasoline	LQ4	N/A	N/A	B	A	B	B	B
Base (B) Equipment Includes:								
Battery 600 CCA (*)	–	B	B	B	B	B	B	B
Provisions for Rear Back-Up Lighting	–	B	B	B	B	B	B	B
Front Tow Hooks	V76	B	B	B	B	B	B	B
Snowplow Prep Pkg. Includes:	VYU							
Upgrade Front Torsion Bar	F60	X	X	X	X	X	X	X
External Engine Oil Cooler LQ4 only	KC4	N/A	N/A	R	R	R	R	R
Generator 145-Amps	KG3	X	X	X	X	X	X	X
Provision for Roof Mntd. Emergency Light	TRW	X	X	X	X	X	X	X
Transmission Cooler (air to oil) Auto only	KNP	X	X	X	X	X	X	X
42mm Hole FOD with Rubber Grommet	–	X	X	X	X	X	X	X
Fwd. Lamp Harness w/In-Line Connector	–	X	X	X	X	X	X	X

(*) Trucks with LB7 (Diesel Engine) come with dual 770 CCA batteries (TQ3) as base equipment B – base vehicle / A – available / X – included in package / Y – included where applicable / N/A – not available on this model / R – required on this model

SNOWPLOW – ONLY ON THE C/K, UTILITY AND CAB CHASSIS

(continued on next page)

SPECIAL APPLICATIONS

2004 Chevrolet/GMC Snowplow Prep Package – Option VYU, Pickup – K15703-K25943 (continued)

Model		K15703	K15903	K25753	K25753 HD	K25743	K25903	K25943
Cab		Regular	Regular	Extended	Extended	Crew	Regular	Crew
Wheelbase Inches		119	133	143.5	143.5	153	133	167
P.U. Box Length feet		6.5	8	6.5	6.5	6.5	8	8
GVWR lb. (option code)		6100(C5M)	6400(C7H)	8600(C6P)	9200(C6W)	9200(C6W)	9200(C6W)	9200(C6W)
GAWR lb. – Frt.		3925	3925	4500	4800	4800	4800	4800
Snowplow Prep Pkg. Includes: (cont.)	VYU							
Mntg. Location for Snowplow Controls	–	X	X	B	B	B	B	B
Skid Plate “Off Road”	NZZ	X	X	X	X	X	X	X
P245/75R16 ALS	–	B	B	N/A	N/A	N/A	N/A	N/A
LT 245/75R16C OOR	–	A	A	N/A	N/A	N/A	N/A	N/A
LT 245/75R16E ALS/OOR TIRES (60 PSI)	–	N/A	N/A	R	R	R	R	R
Suggested Optional Equipment:								
Locking Differential, Rear Axle	G80	A	A	A	A	A	A	A
Battery 770 CCA (*)	7Y9	A	A	A	A	N/A	A	N/A
Batteries – 770 CCA & 600 CCA (*)	8B0	A	A	A	A	N/A	A	N/A
Back-up Alarm – Gas Engine Only	8S3	A	A	A	A	A	A	A
Engine Block Heater	K05	A	A	A	A	A	A	A
Replacement Floor Covering HD Rubber	BG9	A	A	A	A	A	A	A
Rear Window Defogger	C49	A	A	A	A	A	A	A

(*) Trucks with LB7 (Diesel Engine) come with dual 770 CCA batteries (TQ3) as base equipment B – base vehicle / A – available / X – included in package / Y – included where applicable / N/A – not available on this model / R – required on this model

SNOWPLOW – ONLY ON THE C/K, UTILITY AND CAB CHASSIS

(continued on next page)

SPECIAL APPLICATIONS

2004 Chevrolet/GMC Snowplow Prep Package – Option VYU, Pickup – K25953-K35943

Model		K25953	K35903	K35953	K35943	K35903	K35953	K35943
Cab		Extended	Regular	Extended	Crew	Regular	Extended	Crew
Wheelbase Inches		157.5	133.0	157.5	167.0	133.0	157.5	167.0
P.U. Box Length feet		8	8	8	8	8	8	8
GVWR lb. (option code)		9200(C6W)	9900(C4M)	9900(C4M)	9900(C4M)	11400(C7W)	11400(C7W)	11400(C7W)
GAWR lb. – Frt.		4800	4800	4800	4800	4800	4800	4800
Engine Availability with VYU:	Opt. Code							
Vortec 8.1L Gasoline V8 Engine	L18	A	A	A	N/A	A	A	N/A
Duramax 6.6L Diesel V8 Engine	LB7/LLY	N/A	A	N/A	N/A	A	N/A	N/A
Vortec 4800 V8 Gasoline	LR4	N/A	N/A	N/A	N/A	N/A	N/A	N/A
Vortec 5300 V8 Gasoline	LM7	N/A	N/A	N/A	N/A	N/A	N/A	N/A
Vortec 6000 V8 Gasoline	LQ4	B	B	B	B	B	B	B
Base (B) Equipment Includes:								
Battery 600 CCA (*)	–	B	B	B	B	B	B	B
Provisions for Rear Back-Up Lighting	–	B	B	B	B	B	B	B
Front Tow Hooks	V76	B	B	B	B	B	B	B
Snowplow Prep Pkg. Includes:	VYU							
Upgrade Front Torsion Bar	F60	X	X	X	X	X	X	X
External Engine Oil Cooler LQ4 only	KC4	R	R	R	R	R	R	R
Generator 145-Amps	KG3	X	X	X	X	X	X	X
Provision for Roof Mntd. Emergency Light	TRW	X	X	X	X	X	X	X
Transmission Cooler (air to oil) Auto only	KNP	X	X	X	X	X	X	X
42mm Hole FOD with Rubber Grommet	–	X	X	X	X	X	X	X
Fwd. Lamp Harness w/In-Line Connector	–	X	X	X	X	X	X	X

(*) Trucks with LB7 (Diesel Engine) come with dual 770 CCA batteries (TQ3) as base equipment B – base vehicle / A – available / X – included in package / Y – included where applicable / N/A – not available on this model / R – required on this model

SNOWPLOW – ONLY ON THE C/K, UTILITY AND CAB CHASSIS

(continued on next page)

SPECIAL APPLICATIONS

2004 Chevrolet/GMC Snowplow Prep Package – Option VYU, Pickup – K25953-K35943 (continued)

Model		K25953	K35903	K35953	K35943	K35903	K35953	K35943
Cab		Extended	Regular	Extended	Crew	Regular	Extended	Crew
Wheelbase Inches		157.5	133.0	157.5	167.0	133.0	157.5	167.0
P.U. Box Length feet		8	8	8	8	8	8	8
GVWR lb. (option code)		9200(C6W)	9900(C4M)	9900(C4M)	9900(C4M)	11400(C7W)	11400(C7W)	11400(C7W)
GAWR lb. – Frt.		4800	4800	4800	4800	4800	4800	4800
Snowplow Prep Pkg. Includes: (cont.)	VYU							
Mntg. Location for Snowplow Controls	–	B	B	B	B	B	B	B
Skid Plate “Off Road”	NZZ	X	X	X	X	X	X	X
LT 245/75R16E ALS/OOR TIRES (60 PSI)	–	R	N/A	N/A	N/A	N/A	N/A	N/A
LT 215/85R16E ALS/OOR TIRES (70 PSI)	–	N/A	R	R	R	R	B	B
Suggested Optional Equipment:								
Locking Differential, Rear Axle	G80	A	A	A	A	A	A	A
Battery 770 CCA (*)	7Y9	A	A	A	A	A	A	N/A
Batteries – 770 CCA & 600 CCA (*)	8B0	A	A	A	A	A	N/A	A
Back-up Alarm – Gas Engine Only	8S3	A	A	A	A	A	A	A
Engine Block Heater	K05	A	A	A	A	A	A	A
Replacement Floor Covering HD Rubber	BG9	A	A	A	A	A	A	A
Rear Window Defogger	C49	A	A	A	A	A	A	A

(*) Trucks with LB7 (Diesel Engine) come with dual 770 CCA batteries (TQ3) as base equipment B – base vehicle / A – available / X – included in package / Y – included where applicable / N/A – not available on this model / R – required on this model

SNOWPLOW – ONLY ON THE C/K, UTILITY AND CAB CHASSIS

SPECIAL APPLICATIONS

2004 Chevrolet/GMC Snowplow Prep Package – Option VYU, Cab Chassis/Utility

		Cab Chassis			Utility	
Model		K36003	K36053	K36403	K25906	K25936
Cab		Regular	Extended	Regular	–	–
Wheelbase Inches		137.0	161.5	161.5	130.0	130.0
GVWR lb. (option code)		12000 (C7L)	12000 (C7L)	12000 (C7L)	8600 (C6P)	8600 (C6P)
GAWR lb. – Frt.		4800	4800	4800	4180	4380
Engine Availability with VYU:		Opt. Code				
Vortec 8.1L Gasoline V8 Engine	L18	A	A	A	N/A	A
Duramax 6.6L Diesel V8 Engine	LB7/LLY	A	N/A	N/A	N/A	N/A
Vortec 6000 V8 Gasoline	LQ4	B	B	B	B	N/A
Base (B) Equipment Includes:						
Battery 600 CCA (*)	–	B	B	B	B	B
Provisions for Rear Back-Up Lighting	–	B	B	B	N/A	N/A
Tow Hooks	V76	B	B	B	A	A
Snowplow Prep Pkg. Includes:		VYU*				
Upgrade of front torsion bar	F60	X	X	X	X	X
External Eng. Oil Cooler LQ4 only	KC4	R	R	R	R	R
Generator 145-Amps	KG3	X	X	X	B	X
Provision for Roof Mntd. Emergency Light	TRW	X	X	X	X	X
Transmission Cooler (air to oil) Auto only	KNP	X	X	X	X	X
42mm Hole FOD with Rubber Grommet	–	X	X	X	N/A	N/A
Fwd Lamp Harness with In-Line Connector	–	X	X	X	N/A	N/A
Mntg. Location for Snowplow Controls	–	B	B	B	N/A	N/A
Skid Plate “Off Road”	NZZ	X	X	X	A	A

(*) Trucks with LB7 (Diesel Engine) come with dual 600 CCA batteries as base equipment B – base vehicle / A – available / X – included in package / Y – included where applicable / N/A – not available on this model

* Options CF5, WX9, 5G4, Z55, and Exp. Are excluded on the K25906 when VYU is ordered

SNOWPLOW – ONLY ON THE C/K, UTILITY AND CAB CHASSIS

(continued on next page)

SPECIAL APPLICATIONS

2004 Chevrolet/GMC Snowplow Prep Package – Option VYU, Cab Chassis/Utility (cont.)

Model		Cab Chassis			Utility	
		K36003	K36053	K36403	K25906	K25936
Cab		Regular	Extended	Regular	–	–
Wheelbase Inches		137.0	161.5	161.5	130.0	130.0
GVWR lb. (option code)		12000 (C7L)	12000 (C7L)	12000 (C7L)	8600 (C6P)	8600 (C6P)
GAWR lb. – Frt.		4800	4800	4800	4180	4380
Snowplow Prep Pkg. Includes: (cont.)	VYU*					
LT 215/85R16E ALS/OOR TIRES (70 PSI)	–	R	B	B	N/A	N/A
Suggested Optional Equipment:						
Battery 770 CCA (*)	7Y9	A	A	A	A	N/A
Locking Differential, Rear Axle	G80	A	A	A	A	A
Batteries – 770 CCA & 600 CCA (*)	8B0	A	A	A	N/A	N/A
Back-up Alarm – Gas Engine Only	8S3	A	A	A	N/A	N/A
Engine Block Heater	K05	A	A	A	A	A
Replacement Floor Covering HD Rubber	BG9	A	A	A	A	N/A
Rear Window Defogger	C49	A	A	A	A	A

(*) Trucks with LB7 (Diesel Engine) come with dual 600 CCA batteries as base equipment B – base vehicle / A – available / X – included in package / Y – included where applicable / N/A – not available on this model

* Options CF5, WX9, 5G4, Z55, and Exp. Are excluded on the K25906 when VYU is ordered

SNOWPLOW – ONLY ON THE C/K, UTILITY AND CAB CHASSIS

Allowable Center of Gravity Calculation

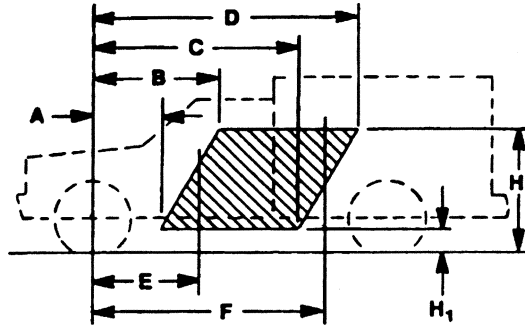

C.G. of vehicle in FMVSS unladen condition (Curb + 400 lbs.) must be inside shaded area – that is, it must be within the trapezoid formed by the coordinates A, B, C, D, H₁, & H₂, plus it must be to the rear of vertical line E and forward of vertical line F.

$$d = \frac{(W_{rc} + W_{rb} + 150) \text{ W.B.}}{W_t}$$

$$h = \frac{(h_1 W_c + h_2 W_b + 10,000)}{W_t}$$

d = horizontal distance from front wheels to completed vehicle center of gravity (inches)

h = vertical distance from ground to completed vehicle center of gravity (inches)

W_{rc} = rear component of bare chassis weight (pounds)

W_{rb} = rear component of body weight (pounds)

W.B. = vehicle wheelbase (inches)

W_t = total weight of chassis, body (pounds) plus 400 pounds

h₁ = center of gravity height from ground of the bare chassis, selected from the following value by model: C/K = 28"

W_c = total weight of bare chassis (pounds)

h₂ = center of gravity height of body from ground (inches)

W_b = total weight of body (pounds)

150 = rear component of 400 pounds (from lightly loaded definition)

10,000 = 400 pounds (from lightly loaded definition) multiplied by its vertical center of gravity height (assumed) of 25 inches

NOTE: An alternate method of center of gravity calculation may be found in the current issue of the General Motors Body Builders Book in the general instruction section and in SVIE Bulletin #39.

SNOWPLOW – ONLY ON THE C/K, UTILITY AND CAB CHASSIS

2004 Allowable Center of Gravity Charts

					Incomplete, Pickup Box Removal, or Snowplow Prep Package Vehicles							
					Coordinates of Allowable C/G Variation at FMVSS Unladen (Curb Wt. + 400 lbs.)						Forward C/G Limit	Rearward C/G Limit
Model	GVWR	Brake System	Wheel base	SRW DRW	H ₁	H ₂	A	B	C	D	E	F
C25906	8600	JH6	130.0	SRW	12	48	36	63	70	97	43	97
K25906	8600	JH6	130.0	SRW	12	48	36	63	70	97	43	97
C15903	6400	JC5	133.0	SRW	12	48	34	59	70	95	44	95
C15753	6200	JC5	143.5	SRW	12	48	37	64	76	102	48	102
C15953	6400	JC5	157.5	SRW	12	48	42	68	79	105	52	105
K15903	6400	JC5	133.0	SRW	12	48	34	59	70	95	44	95
K15753	6400	JC5	143.5	SRW	12	48	37	64	76	102	48	102
K15953	6400	JC5	157.5	SRW	12	48	42	68	79	105	52	105
C15743	8600	JH6	153.0	SRW	12	48	51	77	77	101	51	101
K15743	8600	JH6	153.0	SRW	12	48	51	77	77	101	51	101
C25903	8600	JH6	133.0	SRW	12	48	36	59	70	93	44	93
C25903	9200	JH6	133.0	SRW	12	48	45	71	68	92	45	92
C25753	9200	JH6	143.5	SRW	12	48	48	74	73	96	48	96
C25743	9200	JH6	153.0	SRW	12	48	51	77	77	101	51	101
C25953	9200	JH6	157.5	SRW	12	48	52	78	80	103	52	103
C25943	9200	JH6	167.0	SRW	12	48	55	80	84	107	55	107
K25753	8600	JH6	143.5	SRW	12	48	39	64	76	100	47	100
K25903	9200	JH6	133.0	SRW	12	48	45	71	68	92	45	92
K25753	9200	JH6	143.5	SRW	12	48	48	74	73	96	48	96
K25743	9200	JH6	153.0	SRW	12	48	51	77	77	101	51	101

SRW = Single Rear Wheel
 DRW = Dual Rear Wheel
 C/G = Center of Gravity

Brake Systems:
 Vacuum Powered Boosters JC5
 Hydraulic Powered Boosters JH5, JH6, and JH7

SNOWPLOW – ONLY ON THE C/K, UTILITY AND CAB CHASSIS

(continued on next page)

2004 Allowable Center of Gravity Charts (continued)

					Incomplete, Pickup Box Removal, or Snowplow Prep Package Vehicles							
					Coordinates of Allowable C/G Variation at FMVSS Unladen (Curb Wt. + 400 lbs.)						Forward C/G Limit	Rearward C/G Limit
Model	GVWR	Brake System	Wheel base	SRW DRW	H ₁	H ₂	A	B	C	D	E	F
K25953	9200	JH6	157.5	SRW	12	48	52	78	80	103	52	103
K25943	9200	JH6	167.0	SRW	12	48	55	80	84	107	55	107
K35903	9900	JH6	133.0	SRW	12	48	43	66	64	87	47	87
K35953	9900	JH6	157.5	SRW	12	48	50	73	72	96	54	96
K35943	9900	JH6	167.0	SRW	12	48	52	75	76	100	57	100
C35903	11,400	JH7	133.0	DRW	12	48	41	59	101	109	41	109
C35953	11,400	JH7	157.5	DRW	12	48	48	65	119	128	48	128
C35943	11,400	JH7	167.0	DRW	12	48	50	68	125	135	50	135
K35903	11,400	JH7	133.0	DRW	12	48	41	59	101	109	41	109
K35953	11,400	JH7	157.5	DRW	12	48	48	65	119	128	48	128
K35943	11,400	JH7	167.0	DRW	12	48	50	68	125	135	50	135
C36003	11,400	JH7	137.0	DRW	12	48	43	60	104	112	43	112
C36053	11,400	JH7	161.5	DRW	12	48	49	67	122	131	49	131
C36403	11,400	JH7	161.5	DRW	12	48	49	67	122	131	49	131
C36453	11,400	JH7	185.5	DRW	12	48	55	73	139	148	55	148
K36003	12,000	JH7	137.0	DRW	12	48	43	60	104	112	43	112
K36053	12,000	JH7	161.5	DRW	12	48	49	67	122	131	49	131
K36403	12,000	JH7	161.5	DRW	12	48	49	67	122	131	49	131
K36453	12,000	JH7	185.5	DRW	12	48	55	73	139	148	55	148

SRW = Single Rear Wheel
 DRW = Dual Rear Wheel
 C/G = Center of Gravity

Brake Systems:
 Vacuum Powered Boosters JC5
 Hydraulic Powered Boosters JH5, JH6, and JH7

SNOWPLOW – ONLY ON THE C/K, UTILITY AND CAB CHASSIS

Snowplow Prep Package (VYU) Electrical Provisions

Emergency Roof-Mounted Lamp Switch This provision includes a dash-mounted switch (see Figure 1), a relay, and wiring which is routed up along the Left Hand B pillar that terminates at the roof as coiled blunt cut wires (see Figure 2). There are two blunt cut 12-gauge (3.0 mm²) wires, one is Brown (roof-mounted lamp power), it is controlled by the dash-mounted switch through the relay, the other is Black (ground). The Brown power wire is protected by the 30-Amp SEO 2 fuse which is located in the Underhood Electrical Center.

145-Amp Generator The 145-Amp generator will be equipped on all VYU pickup trucks except those having the Vortec 4300 V6 (L35) engine. The 145-Amp generator is an upgrade from the 105-Amp generator which comes as standard equipment.

Accessory Harness Grommet Trucks will come equipped with a predrilled 42mm pass-through hole located on the dash panel on the left hand side of the vehicle. The hole will be sealed with a grommet (see Figure 3) which can be used by the upfitter for pass-through wiring. To use the grommet (part# 15336702), the upfitter slices off the tape tab end (in engine compartment) of the grommet and then spreads it open to pass wiring through.

Forward Lamp Harness In-Line Connector The forward lamp wiring harness will have a set of mating eight cavity connectors on both the left and right hand side of the vehicle (see Figures 4 & 5). The upfitter will be able to disconnect the in-line connectors which will allow interfacing with the forward lamp circuits (Front Parklamp, Turn Signal and DRL). The headlamp circuits must be accessed from the headlamp connectors. Circuit function charts of these connectors are on page 10. Connector face diagrams of the connectors are on pages 11 and 12. A parts list of these connectors is provided on page 13.

Backup Lamp Power Feed Although this feature is standard on the All New C/K pickup trucks, it should be pointed out that a backup lamp power feed is provided at the rear of the vehicle through the trailer wiring harness. This circuit is protected by the 10-Amp TRLR B/U fuse which is located in the Underhood Electrical Center. On vehicles with Light Duty Trailer Wiring (see Figure 6) which comes standard, this circuit can be accessed through the Light Green trailer wire. This wire is blunt cut and located at the rear of the vehicle along with other trailer tow circuits. On vehicles with Heavy Duty Trailer Wiring option (see Figure 7), this circuit is located in pin A of the trailer in-line connector at the rear of the vehicle.

Figure 1

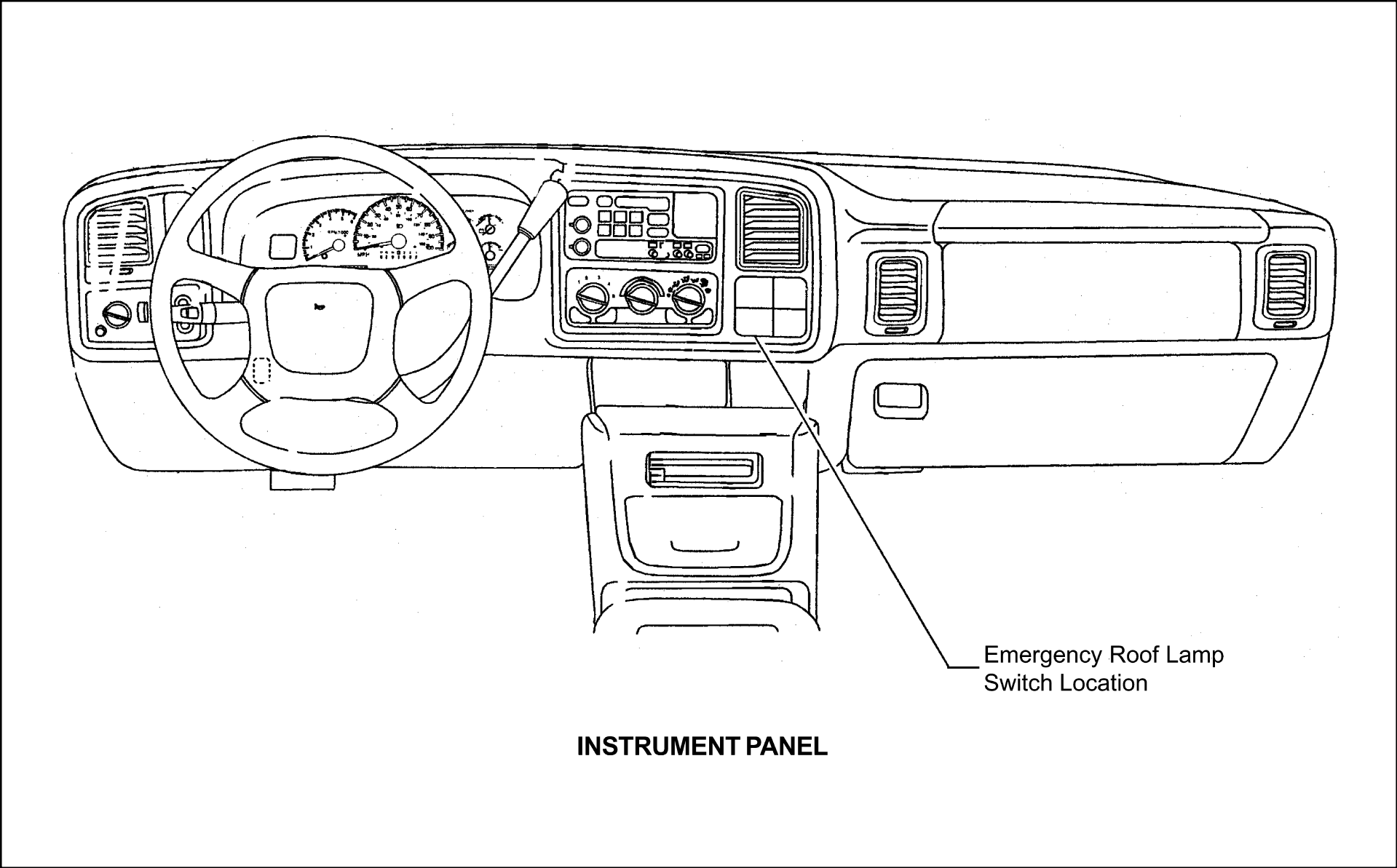

Emergency Roof Lamp
Switch Location

INSTRUMENT PANEL

SNOWPLOW – ONLY ON THE C/K, UTILITY AND CAB CHASSIS

Figure 2

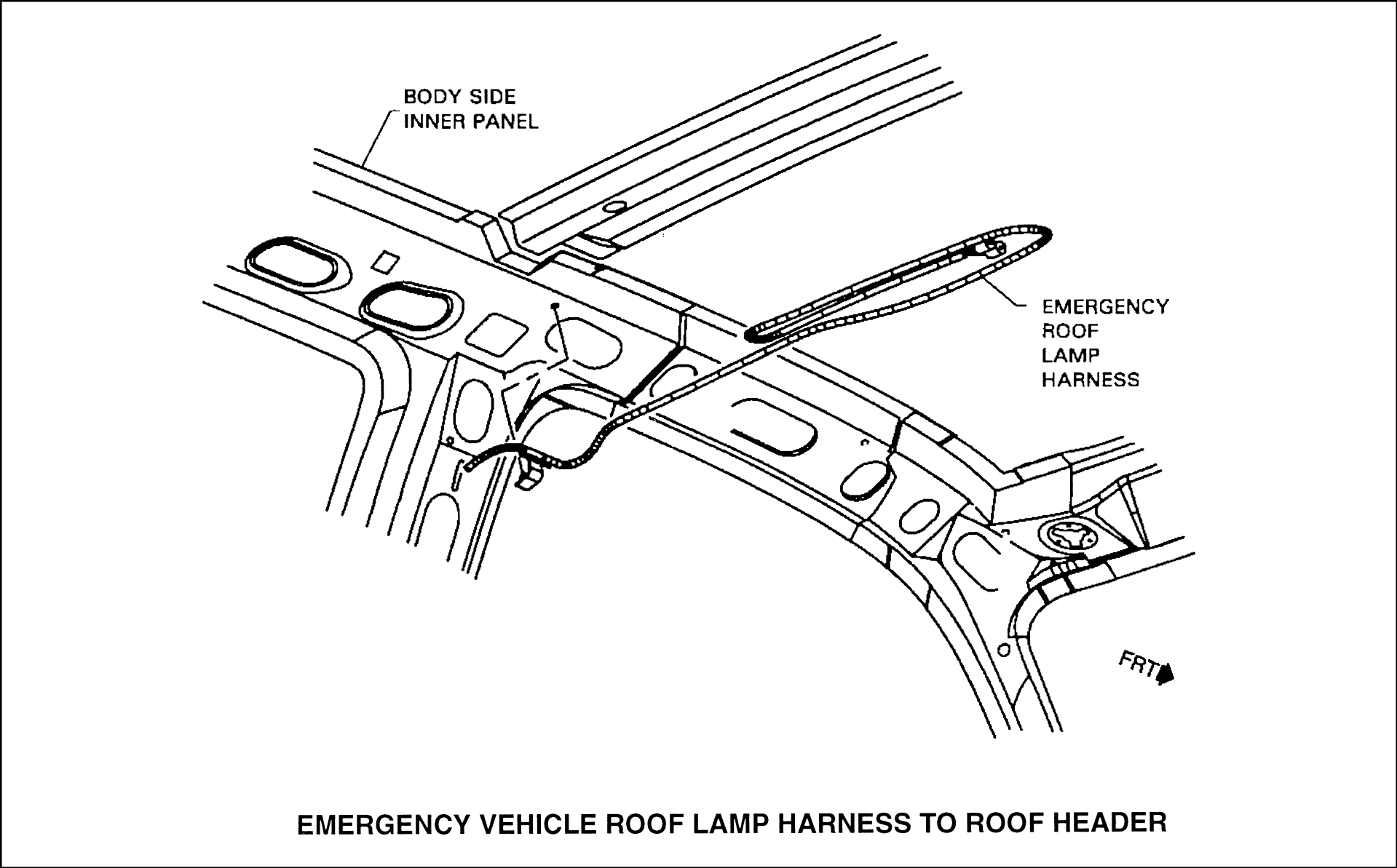

EMERGENCY VEHICLE ROOF LAMP HARNESS TO ROOF HEADER

SNOWPLOW – ONLY ON THE C/K, UTILITY AND CAB CHASSIS

Figure 3

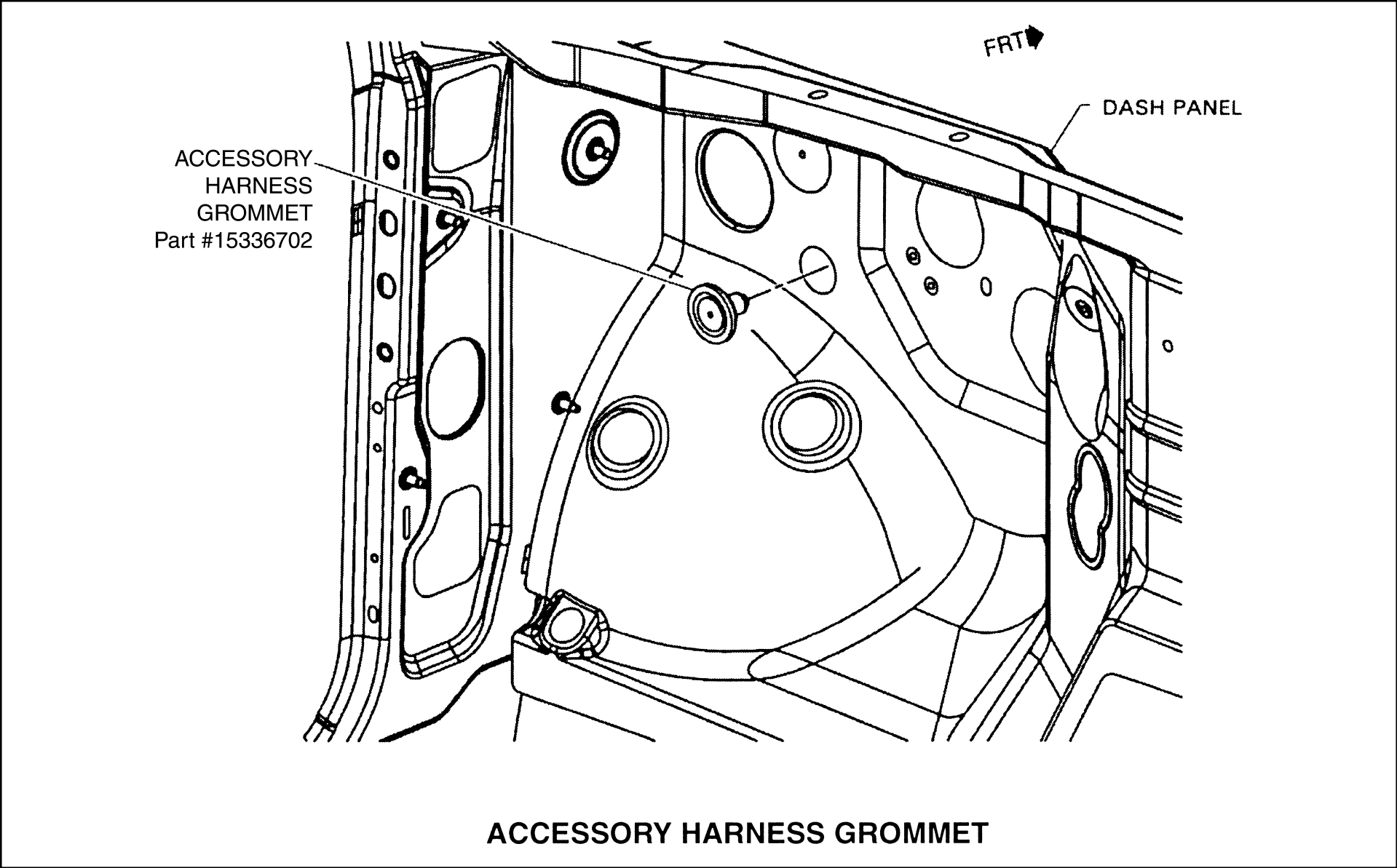

SNOWPLOW – ONLY ON THE C/K, UTILITY AND CAB CHASSIS

Figure 4

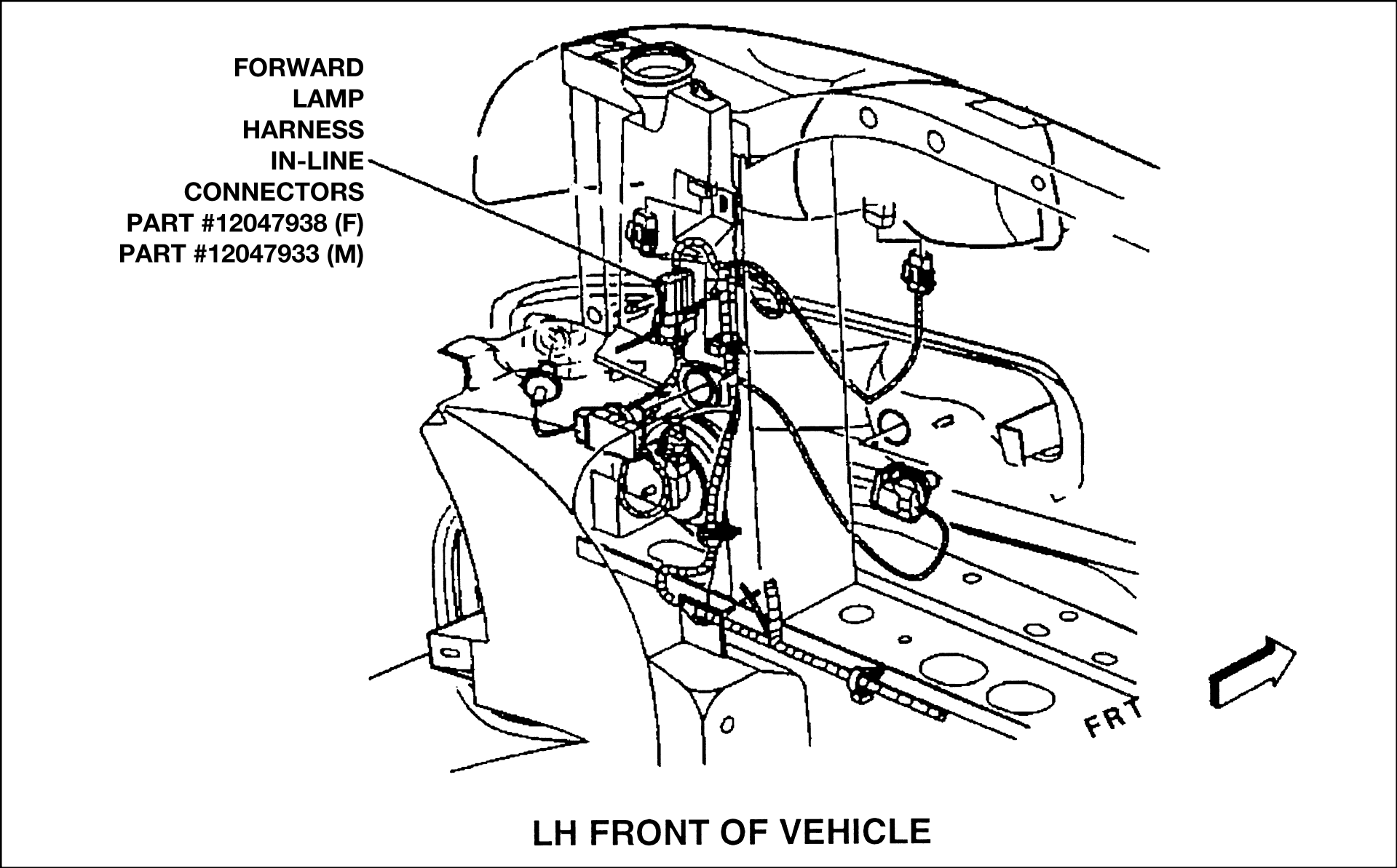

SNOWPLOW – ONLY ON THE C/K, UTILITY AND CAB CHASSIS

Figure 5

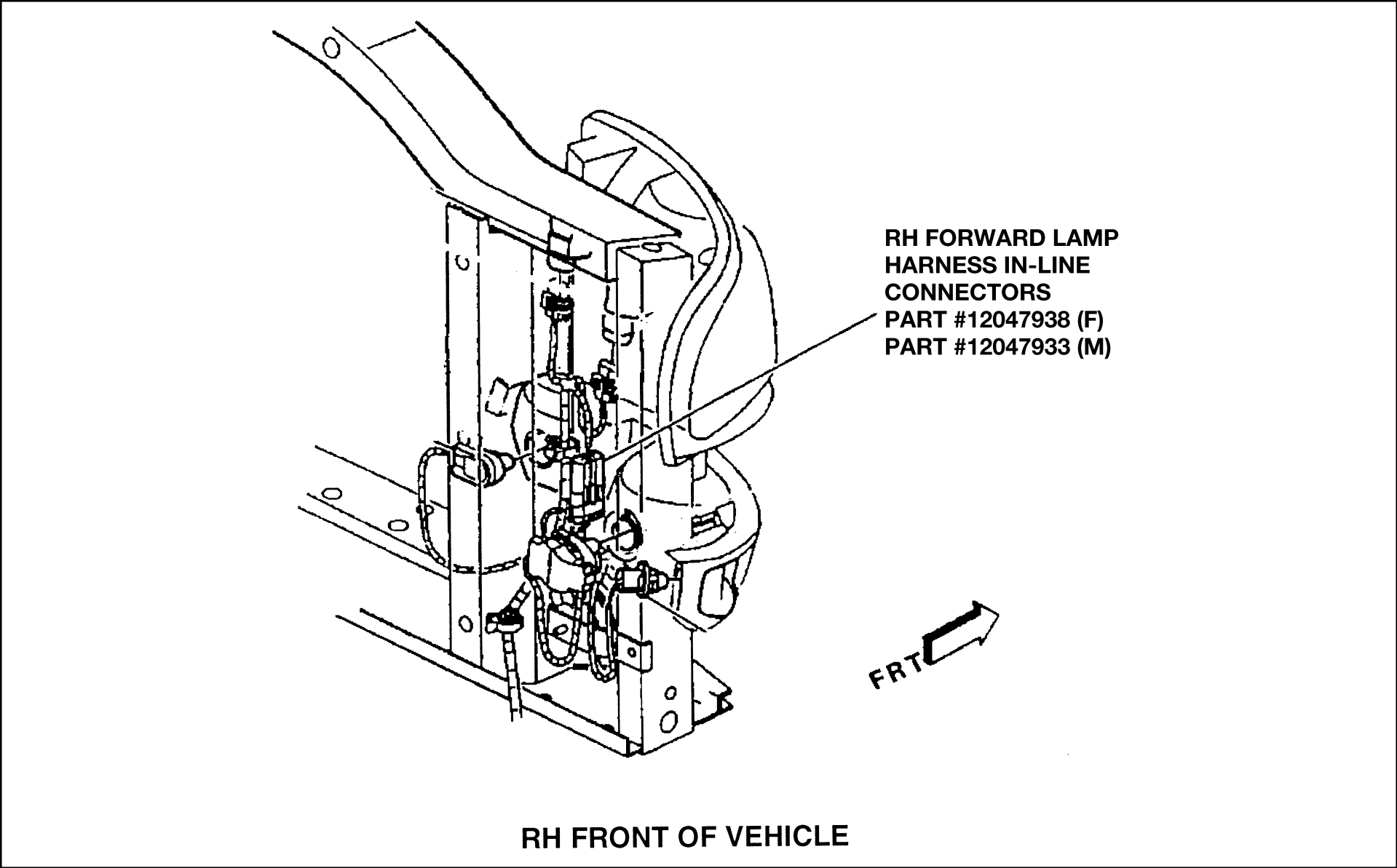

SNOWPLOW – ONLY ON THE C/K, UTILITY AND CAB CHASSIS

Front Exterior Lamp Connector Circuit Function Charts

LH Forward Lamp Harness In-Line Connectors

Cavity	Circuit	Wire Color	Function	Fuse
A	2309	BRN	Front Parklamp	10-Amp FR PARK
B	2309	BRN	Front Parklamp	10-Amp FR PARK
C	2114	LT BLU	Turn Signal – Left	In-line w/LF Side Marker
D	–	–	–	–
E	2114	LT BLU	Turn Signal – Left	10-Amp LT TURN
F	150	BLK	Pk/Turn to Gnd	–
G	545	DK BLU	DRL	10-Amp DRL
H	150	BLK	DRL to Gnd	–

RH Forward Lamp Harness In-Line Connectors

Cavity	Circuit	Wire Color	Function	Fuse
A	2309	BRN	Front Parklamp	10-Amp FR PARK
B	2309	BRN	Front Parklamp	10-Amp FR PARK
C	2115	DK BLU	Turn Signal – Right	In-line w/RT Side Marker
D	–	–	–	–
E	2115	DK BLU	Turn Signal – Right	10-Amp RT TURN
F	150	BLK	Pk/Turn to Gnd	–
G	545	DK BLU	DRL	10-Amp DRL
H	150	BLK	DRL to Gnd	–

NOTE: All fuses referenced above are located in the Underhood Electrical Center.

Front Exterior Lamp Connector Circuit Function Charts (continued)

LH Low Beam Connector

Cavity	Circuit	Wire Color	Function	Fuse
A	712	YEL	Left Low Beam	10-Amp #52 LO HDLP-LT
B	550	BLK	Ground	---

RH Low Beam Connector

Cavity	Circuit	Wire Color	Function	Fuse
A	312	TAN/WHT	Right Low Beam	10-Amp #55 LO HDLP-RT
B	150	BLK	Ground	---

LH High Beam Connector

Cavity	Circuit	Wire Color	Function	Fuse
A	711	DK GRN/WHT	Left High Beam	10-Amp #59 HI HDLP-LT
B	550	BLK	Ground	---

RH High Beam Connector

Cavity	Circuit	Wire Color	Function	Fuse
A	311	LT GRN/BLK	Right High Beam	10-Amp #46 HI HDLP-RT
B	150	BLK	Ground	---

NOTE: All fuses referenced above are located in the Underhood Electrical Center.

SNOWPLOW — ONLY ON THE C/K, UTILITY AND CAB CHASSIS

Forward Lamp Harness In-Line Connectors

**FORWARD LAMP
HARNESS IN-LINE
CONNECTOR [F]
PART # 12047938**

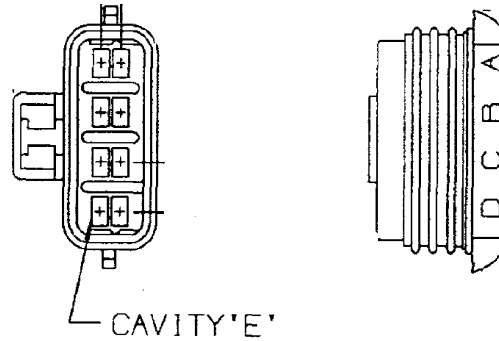

Assembly	Components	Gender	Blocked Cavity	Notes	Color	Typical Terminal	Mating Part	Secondary Lock
1204 7938	12047934 Connector 12047939 Connector Seal	F	D	1. 12020833 CPA 2. 12048086 Cable Seal	LT GRA	12048074	12047933	12066304

**FORWARD LAMP
HARNESS IN-LINE
CONNECTOR [M]
PART # 12047933**

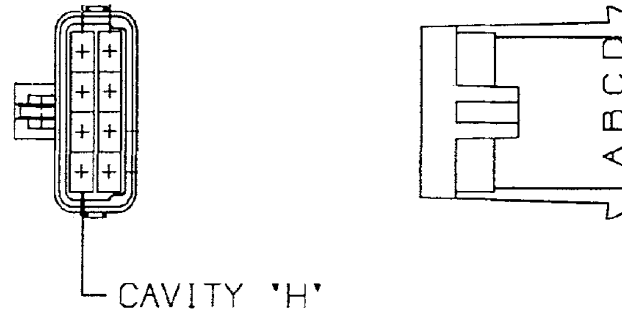

Assembly	Components	Gender	Blocked Cavity	Notes	Color	Typical Terminal	Mating Part	Secondary Lock
12047933		M	D	1. 12020833 CPA 2. 12048086 Cable Seal	GRA	12045773	12047938	12047936

SNOWPLOW – ONLY ON THE C/K, UTILITY AND CAB CHASSIS

Headlamp Connectors

**LOW BEAM
CONNECTOR [F]
PART # 12059181**

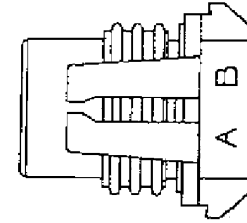
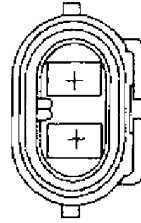

**HIGH BEAM
CONNECTOR [F]
PART # 12059183**

Assembly	Components	Gender	Notes	Color	Typical Terminal	Mating Part	Secondary Lock
12059181	12059180 Connector 12059184 Connector Seal	F	12015323 Cable Seal	MD GRA	12077411	12084166	12059185
12059183	12059182 Connector 12059184 Connector Seal	F	12015323 Cable Seal	BLK	12077411	12084167	12059185

**LOW BEAM
CONNECTOR [M]
PART # 12084166**

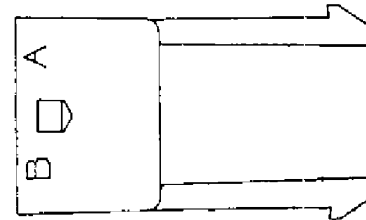
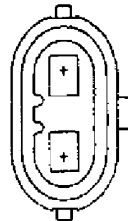

**HIGH BEAM
CONNECTOR [M]
PART # 12084167**

Assembly	Components	Gender	Notes	Color	Typical Terminal	Mating Part	Secondary Lock
12084166		M	12015323 Cable Seal	MD GRA	12048159	12059181	12059185
12084167		M	12015323 Cable Seal	BLK	12048159	12059183	12059185

SNOWPLOW – ONLY ON THE C/K, UTILITY AND CAB CHASSIS

Front Exterior Lamp Electrical Connector Part Numbers

Part #	Connector
12047938	FORWARD LAMP IN-LINE HARNESS CONNECTOR (F)
12047933	FORWARD LAMP IN-LINE HARNESS CONNECTOR (M)
12059181	LOW BEAM CONNECTOR (F) (ON VEHICLE)
12084166	LOW BEAM CONNECTOR (M)
12059183	HIGH BEAM CONNECTOR (F) (ON VEHICLE)
12084167	HIGH BEAM CONNECTOR (M)

NOTE: Terminals and secondary locks may have to be ordered separately. Further details regarding the connectors can be obtained from the Delphi Products Handbooks or by calling 1-800-PACKARD (1-800-722-5273).

SNOWPLOW – ONLY ON THE C/K, UTILITY AND CAB CHASSIS

Figure 6

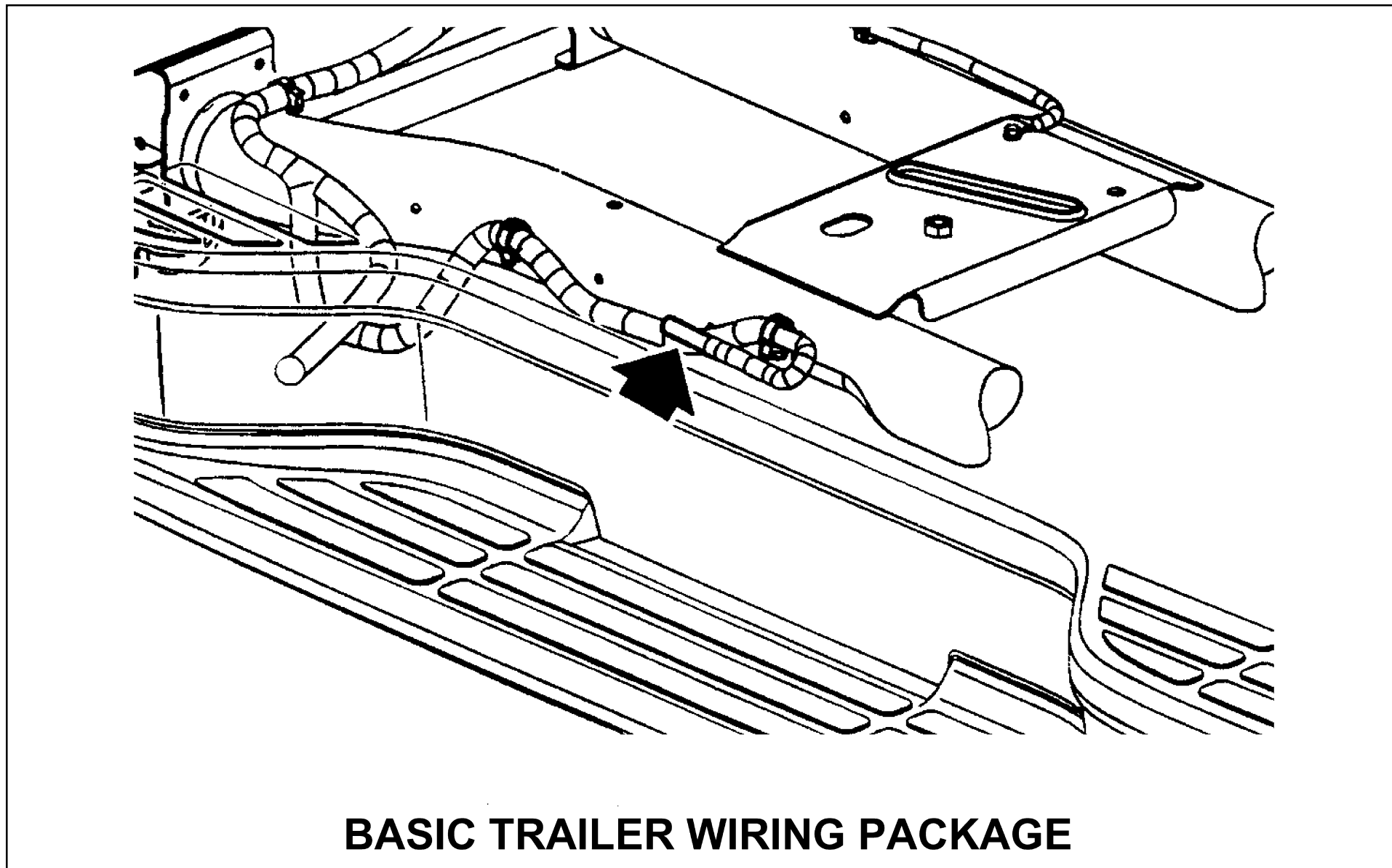

BASIC TRAILER WIRING PACKAGE

SNOWPLOW – ONLY ON THE C/K, UTILITY AND CAB CHASSIS

Figure 7

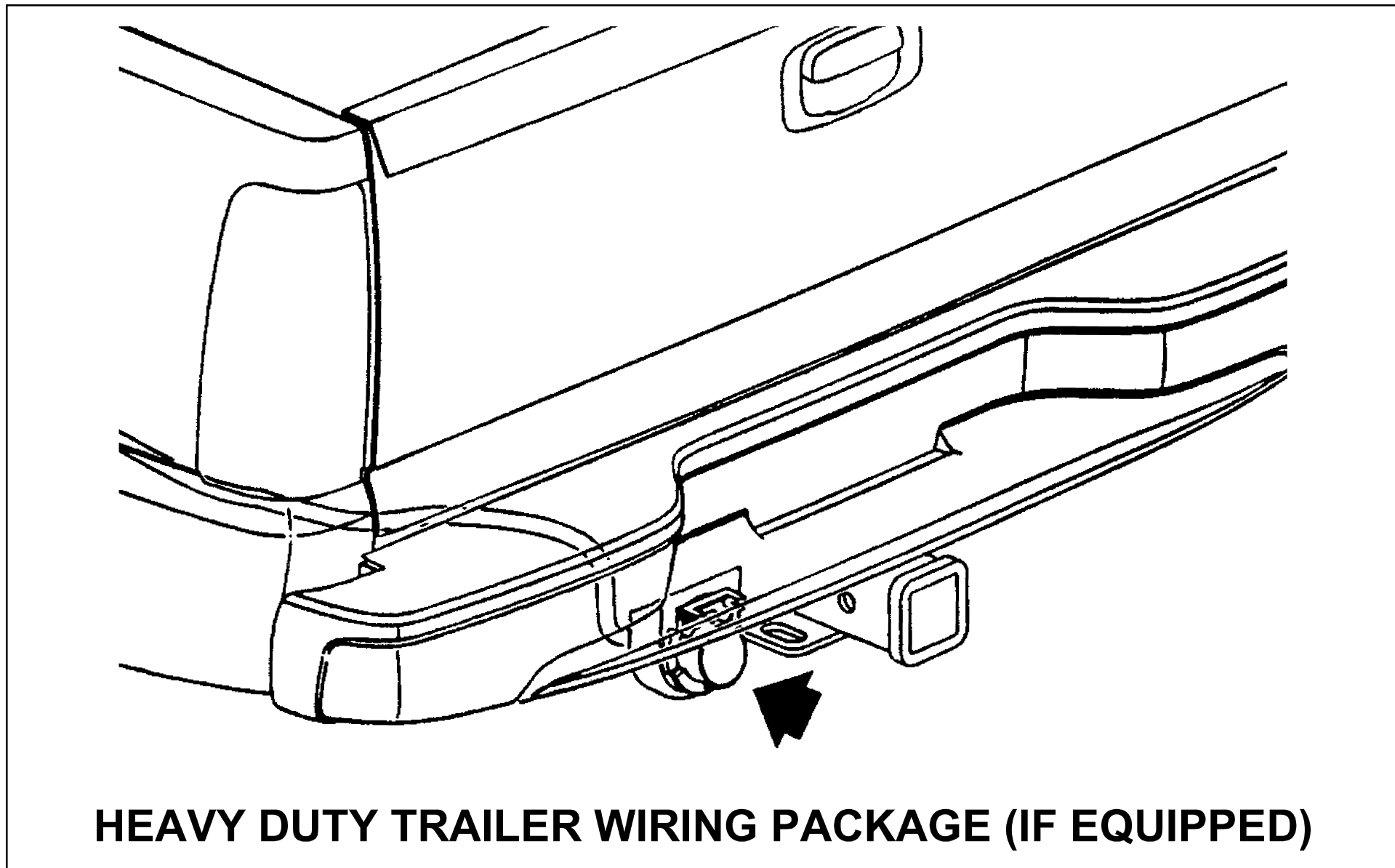

SNOWPLOW – ONLY ON THE C/K, UTILITY AND CAB CHASSIS

PICKUP BOX REMOVAL PROGRAM

Alterations to Complete Vehicles

Persons who alter complete (certified) Pickup Trucks by removal of the Pickup box should be aware that this type of activity would impose upon them the corresponding responsibility for ensuring that the units as sold are in compliance with all applicable safety and/or emissions (including noise and RFI) requirements. Specific questions concerning compliance or certification to these requirements should be directed to the vehicle alterer's legal counsel or the National Highway Traffic Safety Administration, the Environmental Protection Agency, the California Air Resources Board, or in Canada, the Ministry of Transport or the Canadian Department of Commerce.

The Environmental Protection Agency has provided an explanation of the policy they will follow regarding the modification by the secondary manufacturers of complete Light Duty Trucks prior to sale and delivery to the ultimate purchaser. This explanation is contained in a letter from C. N. Freed of the EPA to M.M. McBride of the Recreation Vehicle Industry Association, dated July 13, 1979. A portion of this letter states:

“...Secondary manufacturers are not manufacturers under the act when the following conditions are met:

1. The vehicles produced by a secondary manufacturer conform in all material respects to the design specification in the original manufacturer's application for certification (hereafter 'application'); and
2. The weight of the vehicle produced by a secondary manufacturer, including the weight of fuel at nominal tank capacity, is no more than 500 lbs. above the maximum vehicle weight.”

No frontal area restrictions will apply to secondary manufacturers who comply with the conditions above. However, every vehicle sold to an ultimate purchaser must be covered by emission warranty mandated by section 270(a) of the Act. Secondary manufacturers who do not meet the above conditions will be considered manufacturers under the Act and will be required to ensure that the vehicles they produce are covered by a certificate of conformity.

The Maximum vehicle weight for a given vehicle is determined by:

- A) Subtracting 300 lbs. from the highest loaded vehicle weight (see 40 CFR 86.079-2 for loaded vehicle weight definition and the table at 40 CFR 86.129-80) associated with the test weight listed in the application for the vehicle, and
- B) Adding the weight of all options that are offered by the original manufacturer for the applicable truck line that were not included in the curb weight reported in the application.

(Alterations – continued on next page)

(Alterations – continued from previous page)

In the case of mutually exclusive options, only the weight of the heavier option is to be used when computing the maximum vehicle weight.

Those who wish to remove the Pickup box from a Pickup Truck for the purpose of installing special equipment or another type of body should be further advised that a Pickup may require modification in one of the following areas. Before a decision is made to alter a C/K Pickup Model, please be advised of the following considerations:

Vehicle:

Analyze the vehicle specifications for product content. The option content of a particular vehicle will determine which if any of the five areas of modification might not be applicable to the vehicle alterations contemplated.

Service Parts:

The service parts and related service part number as outlined in the four areas of modification may be ordered through your local Chevrolet/GMC Dealer. Contact your Dealer's Service Parts Representative for availability and price.

Areas of Modification:

1. Fuel filler neck assembly, housing, and ground strap.
2. Rear axle vent hose.
3. Tail lamp, tail lamp wiring harness and license plate bracket assembly.
4. Spare tire mounting.
5. Body pressure relief valve (see UI Bulletin #44).

Federal Motor Vehicle Safety Standards

FMVSS 101 – Controls and Displays

- A The following statement is applicable to Chassis Cab, Cutaway Van, Suburban, Van, Pickup and Utility with a GVWR of 10,000 lbs. or less (unless otherwise noted on the cover of this document).**

This incomplete vehicle, when completed, will conform to FMVSS 101 providing no alterations are made which affect the size, location, identification or illumination of the controls and displays identified below or the location, travel and type of seat. If the seat is installed by the final stage manufacturer, the visibility and operation of the controls and displays listed below must meet the requirements of paragraph S5 of the standard:

Vehicle and system controls and displays including:

Hazard warning signal control and tell-tale	Engine coolant temperature display
High beam control and indicator	Rear window defrosting and defogging controls
Steering wheel	Manual transmission shift lever, except transfer case
Service brake	Heating system controls (including fan)
Accelerator	Air conditioning system controls (including fan)
Horn control	Engine start control
Clutch	Engine stop control
Ignition control	Hand throttle control
Gear position display	Clearance lamp control
Headlamp control	Side marker lamp control
Turn signal, control and display	Identification lamp control
Brake failure warning display	Windshield defrosting and defogging controls
Illumination intensity control	Speedometer display
Fuel level display	* Odometer (must be metric)
Windshield wiper control	* Trip recorder (must be metric)
Windshield washer control	* Hub odometer (must be metric)
Oil pressure display	Automatic vehicle speed control
Electrical charge display	Seat belt tell-tale
Manual choke control	Anti-lock brake failure warning display
Tail lamps/control	Air bag tell-tale (if so equipped)

* For Canada MVSS only, when Canadian option is specified.

FMVSS 102 – Transmission Shift Lever Sequence, Starter Interlock and Transmission Braking Effect

A The following statement is applicable to Chassis Cab, Van, Pickup, Utility and Suburban (unless otherwise noted on the cover of this document).

This incomplete vehicle, when completed, will conform to FMVSS 102 providing no alterations are made which affect the function, physical or mechanical properties, environment, location or vital spatial clearances of the components, assemblies or systems identified below:

1. Transmission control and identification system, including but not limited to:

Automatic transmission assembly (A/T)	A/T neutral safety back-up switch assembly and wire
A/T control from steering column to transmission linkage	Vehicle wiring harness
A/T control from floor shift mechanism to transmission linkage	A/T position indicator dial
A/T steering column assembly	A/T position indicator pointer
A/T floor shift mechanism	A/T position indicator actuating linkage
	Transmission shift position pattern (knob, plate or label)

FMVSS 103 – Windshield Defrosting and Defogging Systems

A The following statement is applicable to Chassis Cab and Cutaway Van (unless otherwise noted on the cover of this document).

This incomplete vehicle, when completed, will conform to FMVSS 103 providing no alterations are made which affect the function, physical or mechanical properties, environment, location or vital spatial clearances of the components, assemblies or systems identified below:

Windshield defrosting and defogging systems, including but limited to:

Windshield assembly	Heater and defroster control
Heater and defroster assembly (including motor and blower)	(electrical, mechanical, vacuum)
Heater and water hoses/hose assemblies	Vacuum control hoses
Heater blower motor resistor assembly	Defroster air distributor assembly (manifold)
Defroster air duct assembly	Defroster air to windshield outlet assembly (nozzle) (it affects high blower speed)
Defroster air hoses (distributor to nozzle)	Engine water outlet thermostat assembly
Defroster outlet to heater assembly adaptor	Heater and air conditioning wiring harness
Chassis and instrument panel wiring harness assembly	Engine wiring harness

FMVSS 104 – Windshield Wiping and Washing Systems

A The following statement is applicable to Chassis Cab, Cutaway Van, Pickup, Utility, Van and Suburban (unless otherwise noted on the cover of this document).

This incomplete vehicle, when completed, will conform to FMVSS 104 providing no alterations are made which affect the function, physical or mechanical properties, environment, location or vital spatial clearances of the components, assemblies or systems identified below:

Windshield wiping and washing systems, including but limited to:

Windshield assembly	Windshield washer fluid reservoir
Windshield wiper arm assembly	Washer reservoir cap
Windshield wiper blade assembly	Water reservoir filler assembly
Windshield wiper linkage assembly	Windshield washing system hoses
Windshield wiper/washer control	Windshield washer nozzle
Windshield wiper/washer motor/pump assembly	Vehicle wiring harness
Windshield module attachments	

FMVSS 105 – Hydraulic Service Brake, Emergency and Parking Brake Services

Allowable center of gravity variation (C/K, G Van, M/L Van).

These charts detail the envelope of allowable center of gravity variation for completed vehicles. This is significant for the lightly loaded portion of FMVSS 105, which is defined as curb plus 400 pounds distributed in the driver-passenger area of the vehicle.

The lightly loaded center of gravity of complete vehicles needs to be restricted so it will meet FMVSS 105 stopping distances. The laden center of gravity does not need to be specified as it is controlled within the FMVSS 105 test procedure by specific instructions as to how ballast is to be placed (while height is not controlled, it is assumed that for test purposes it would be reasonable).

Allowable Center of Gravity Calculation

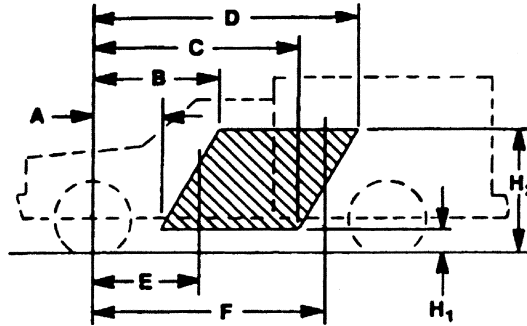

C.G. of vehicle in FMVSS unladen condition (Curb + 400 lbs.) must be inside shaded area – that is, it must be within the trapezoid formed by the coordinates A, B, C, D, H₁, & H₂, plus it must be to the rear of vertical line E and forward of vertical line F.

$$d = \frac{(W_{rc} + W_{rb} + 150) \text{ W.B.}}{W_t}$$

$$h = \frac{(h_1 W_c + h_2 W_b + 10,000)}{W_t}$$

d = horizontal distance from front wheels to completed vehicle center of gravity (inches)

h = vertical distance from ground to completed vehicle center of gravity (inches)

W_{rc} = rear component of bare chassis weight (pounds)

W_{rb} = rear component of body weight (pounds)

W.B. = vehicle wheelbase (inches)

W_t = total weight of chassis, body (pounds) plus 400 pounds

h₁ = center of gravity height from ground of the bare chassis, selected from the following value by model: C/K = 28", G = 32", M/L = 28", P30 = 24"

W_c = total weight of bare chassis (pounds)

h₂ = center of gravity height of body from ground (inches)

W_b = total weight of body (pounds)

150 = rear component of 400 pounds (from lightly loaded definition)

10,000 = 400 pounds (from lightly loaded definition) multiplied by its vertical center of gravity height (assumed) of 25 inches

NOTE: An alternate method of center of gravity calculation may be found in the current issue of the General Motors Body Builders Book in the general instruction section and in SVIE Bulletin #39.

2004 Allowable Center of Gravity Charts

					Incomplete, Pickup Box Removal, or Snowplow Prep Package Vehicles							
					Coordinates of Allowable C/G Variation at FMVSS Unladen (Curb Wt. + 400 lbs.)						Forward C/G Limit	Rearward C/G Limit
Model	GVWR	Brake System	Wheel base	SRW DRW	H ₁	H ₂	A	B	C	D	E	F
C25906	8600	JH6	130.0	SRW	12	48	36	63	70	97	43	97
K25906	8600	JH6	130.0	SRW	12	48	36	63	70	97	43	97
S10803	4900	JM3	117.9	SRW	13.4	36.6	37	45.8	88	95	N/A	N/A
C15903	6400	JC5	133.0	SRW	12	48	34	59	70	95	44	95
C15753	6200	JC5	143.5	SRW	12	48	37	64	76	102	48	102
C15953	6400	JC5	157.5	SRW	12	48	42	68	79	105	52	105
K15903	6400	JC5	133.0	SRW	12	48	34	59	70	95	44	95
K15753	6400	JC5	143.5	SRW	12	48	37	64	76	102	48	102
K15953	6400	JC5	157.5	SRW	12	48	42	68	79	105	52	105
C15743	8600	JH6	153.0	SRW	12	48	51	77	77	101	51	101
K15743	8600	JH6	153.0	SRW	12	48	51	77	77	101	51	101
C25903	8600	JH6	133.0	SRW	12	48	36	59	70	93	44	93
C25903	9200	JH6	133.0	SRW	12	48	45	71	68	92	45	92
C25753	9200	JH6	143.5	SRW	12	48	48	74	73	96	48	96
C25743	9200	JH6	153.0	SRW	12	48	51	77	77	101	51	101
C25953	9200	JH6	157.5	SRW	12	48	52	78	80	103	52	103
C25943	9200	JH6	167.0	SRW	12	48	55	80	84	107	55	107
K25753	8600	JH6	143.5	SRW	12	48	39	64	76	100	47	100
K25903	9200	JH6	133.0	SRW	12	48	45	71	68	92	45	92

SRW = Single Rear Wheel
 DRW = Dual Rear Wheel
 C/G = Center of Gravity

Brake Systems:
 Vacuum Powered Boosters JC5
 Hydraulic Powered Boosters JH5, JH6, JH7, and JM3

2004 Allowable Center of Gravity Charts (continued)

					Incomplete, Pickup Box Removal, or Snowplow Prep Package Vehicles							
					Coordinates of Allowable C/G Variation at FMVSS Unladen (Curb Wt. + 400 lbs.)						Forward C/G Limit	Rearward C/G Limit
Model	GVWR	Brake System	Wheel base	SRW DRW	H ₁	H ₂	A	B	C	D	E	F
K25753	9200	JH6	143.5	SRW	12	48	48	74	73	96	48	96
K25743	9200	JH6	153.0	SRW	12	48	51	77	77	101	51	101
K25953	9200	JH6	157.5	SRW	12	48	52	78	80	103	52	103
K25943	9200	JH6	167.0	SRW	12	48	55	80	84	107	55	107
K35903	9900	JH6	133.0	SRW	12	48	43	66	64	87	47	87
K35953	9900	JH6	167.0	SRW	12	48	50	73	72	96	54	96
K35943	9900	JH6	157.5	SRW	12	48	52	75	76	100	57	100
C35903	11,400	JH7	133.0	DRW	12	48	41	59	101	109	41	109
C35953	11,400	JH7	157.5	DRW	12	48	48	65	119	128	48	128
C35943	11,400	JH7	167.0	DRW	12	48	50	68	125	135	50	135
K35903	11,400	JH7	133.0	DRW	12	48	41	59	101	109	41	109
K35953	11,400	JH7	157.5	DRW	12	48	48	65	119	128	48	128
K35943	11,400	JH7	167.0	DRW	12	48	50	68	125	135	50	135
C36003	11,400	JH7	137.0	DRW	12	48	43	60	104	112	43	112
C36053	11,400	JH7	161.5	DRW	12	48	49	67	122	131	49	131

SRW = Single Rear Wheel
 DRW = Dual Rear Wheel
 C/G = Center of Gravity

Brake Systems:
 Vacuum Powered Boosters JC5
 Hydraulic Powered Boosters JH5, JH6, JH7, and JM3

2004 Allowable Center of Gravity Charts (continued)

					Incomplete, Pickup Box Removal, or Snowplow Prep Package Vehicles							
					Coordinates of Allowable C/G Variation at FMVSS Unladen (Curb Wt. + 400 lbs.)						Forward C/G Limit	Rearward C/G Limit
Model	GVWR	Brake System	Wheel base	SRW DRW	H ₁	H ₂	A	B	C	D	E	F
C36403	11,400	JH7	161.5	DRW	12	48	49	67	122	131	49	131
C36453	11,400	JH7	185.5	DRW	12	48	55	73	139	148	55	148
K36003	12,000	JH7	137.0	DRW	12	48	43	60	104	112	43	112
K36053	12,000	JH7	161.5	DRW	12	48	49	67	122	131	49	131
K36403	12,000	JH7	161.5	DRW	12	48	49	67	122	131	49	131
K36453	12,000	JH7	185.5	DRW	12	48	55	73	139	148	55	148

SRW = Single Rear Wheel
 DRW = Dual Rear Wheel
 C/G = Center of Gravity

Brake Systems:
 Vacuum Powered Boosters JC5
 Hydraulic Powered Boosters JH5, JH6, JH7, and JM3

FMVSS 106 – Brake Hoses

A The following statement is applicable to all types of incomplete vehicles (unless otherwise noted on the cover of this document).

This incomplete vehicle, when completed, will conform to FMVSS 106 providing no alterations are made which affect the function, physical or mechanical properties, environment, location or vital spatial clearances of the components, assemblies or systems identified below:

Hoses and hose end fittings

Labeling requirements

FMVSS 108 – Lamps, Reflective Devices and Associated Equipment

A The following statement is applicable to Chassis Cab (unless otherwise noted on the cover of this document).

This incomplete vehicle, when completed, will conform to FMVSS 108 if it is completed with a body over 80 inches wide providing the following conditions are met:

1. Each of these devices must be properly installed on the completed vehicle and meet all the requirements of FMVSS 108:
 - a. The following devices when provided, located and/or wired by General Motors meet the requirements of this standard:

Headlamps and/or foglamps	Front cab roof clearance and identification lamps
Front side marker reflex reflectors	Rear reflex reflectors
Front side marker lamps	Tail lamps
Front turn signal lamps	Stop lamps
Turn signal operating unit	License plate lamp
Turn signal flasher	Rear turn signal lamps
Vehicle hazard warning signal operating unit	Back-up lamps
Vehicle hazard warning signal flasher	Center high-mounted stop lamp
Mud flaps w/reflectors (Tractor only)	Rear cab conspicuity reflectors (Tractor only)
 - b. No part of the completed vehicle shall be installed so as to prevent any of the devices listed in (a) above from meeting their required photometric output at the specified test points. If such interference exists, the applicable devices may have to be relocated or additional devices added to meet the requirements of FMVSS 108. Any FMVSS 108 part shall not be painted.
 - c. The following additional devices must be installed on the van body and meet all the requirements of this standard:

Rear side marker lamps	Rear side marker reflex reflectors
Front and rear clearance lamps	Front and rear identification lamps

(FMVSS 108 – continued on next page)

(FMVSS 108 – continued from previous page)

- d. The following additional devices must be installed on the van body and meet all the requirements of this standard if the overall vehicle length is 30 feet or greater:
- | | |
|--------------------------------|-------------------------------------|
| Intermediate side marker lamps | Intermediate side reflex reflectors |
|--------------------------------|-------------------------------------|
- e. C/K 300(03) and Medium Duty C6, C7, F7 Chassis Cabs with Roof Marker Lamp – Delete, Option 9H5 will comply with Standard 108 provided clearance and identification marker lamps are installed on the completed vehicle.
2. No alterations (other than any relocation of items in 1(a) which may be necessary to conform to the standard) should be made which affect the location, mounting surfaces, function, environment or visibility clearance of the above listed devices which have been installed on this incomplete vehicle.
- # Body Builders or Dealers, after removing wooden shipping bumper, must relocate rear tail, stop and turn lights by switching the left hand and right hand brackets and lamp assembly so that the lights are mounted outboard of the shipping position. Two additional installation bolts are included in the Incomplete Vehicle Document Envelope.

FMVSS 111 – Rearview Mirrors

B The following statement is applicable to a 1500/2500/3500 Series Chassis Cab (unless otherwise noted on the cover of this document).

This incomplete vehicle, when completed, will conform to FMVSS 111 providing there is conformity to the following appropriate requirements: (1) the driver's seat location is not altered and a body, of not more than 80 inches in overall width, is installed symmetrically about the vehicle centerline; (2) when outside rearview mirror option DF2, DG5, 8B2, 8G9, 9F7 or 9F8 is ordered and the driver's seat location is not altered and a body, of not more than 96 inches in overall width, is installed symmetrically about the vehicle centerline; (3) when the seat is installed by the final stage manufacturer (w/8E2) in a different location than a production vehicle, the vehicle will conform to the requirements of paragraph S6 or S7 of FMVSS 111 when outside rearview mirror option DF2, DG5, 8B2, 8G9, 9F7 or 9F8 is ordered and a body, of not more than 96 inches overall width, is installed symmetrically about the vehicle centerline.

E The following statement is applicable to M/L05/06 Van, Suburban, G05, 06 Vans, ST Pickup and Blazer/Yukon (unless otherwise noted on the cover of this document).

This vehicle will conform to FMVSS 111 providing no alterations or substitutions are made to the outside or inside mirrors furnished with the vehicle, the driver's seat location is not altered and the body width is not increased.

FMVSS 112 – Headlamp Concealment Devices

- A The following statement is applicable to all four basic types of incomplete vehicles (unless otherwise noted on the cover of this document).**

Conformity with FMVSS 112 is not substantially affected by the design of this incomplete vehicle and General Motors makes no representation as to the conformity with this standard.

FMVSS 113 – Hood Latch System

- A The following statement is applicable to Chassis Cab, Van, Cutaway Van, Utility and Suburban (unless otherwise noted on the cover of this document).**

This incomplete vehicle, when completed, will conform to FMVSS 113 providing no alterations are made which affect the function, physical or mechanical properties, environment, location or vital spatial clearances of the components, assemblies or systems identified below:

Hood latch systems, which may include but are not limited to:

- Hood latch (catch) assembly
- Hood latch support assembly
- Hood latch pilot
- Hood latch striker plate (hook)

FMVSS 114 – Theft Protection (GVWR of 10,000 Pounds or Less)

- A The following statement is applicable to Chassis Cab, Bare Chassis, Van and Cutaway Van (unless otherwise noted on the cover of this document).**

This incomplete vehicle, when completed, will conform to FMVSS 114 providing no alterations are made which affect the function, physical or mechanical properties, environment, location or vital spatial clearances of the components, assemblies or systems identified below:

- Steering column lock assembly

U.S. CFR 49, PART 565/CMVSS 115 – Vehicle Identification Number

A The following statement is applicable to all incomplete vehicles (unless otherwise noted on the cover of this document).

This incomplete vehicle, when completed, will conform to CMVSS 115 and U.S. CFR 49, part 567, providing no alterations are made to the Vehicle Identification Number or to the environment, location, vital spatial clearances or visibility of the VIN Plate.

FMVSS 116 – Motor Vehicle Brake Fluids

A The following statement is applicable to all three basic types of incomplete vehicles (unless otherwise noted on the cover of this document).

This incomplete vehicle, when equipped with approved hydraulic brake fluid will conform to FMVSS 116 providing no alterations are made which affect the physical or chemical properties of the brake fluid.

FMVSS 120 – Tire Selection and Rims for Vehicles Other than Passenger Cars

A The following statement is applicable to all three basic types of incomplete vehicles (unless otherwise noted on the cover of this document).

This incomplete vehicle, when completed, will conform to FMVSS 120 providing no alterations are made which affect the function, physical or mechanical properties or the attachment of the wheels and tires.

The tire and wheel information shown on the Incomplete Vehicle Document Label must be transferred to the final stage manufacturer's Certification label or Tire Information Label providing no equipment changes are made.

FMVSS 124 – Accelerator Control Systems

A The following statement is applicable to Chassis Cab, Van and Cutaway Van (unless otherwise noted on the cover of this document).

This incomplete vehicle, when completed, will conform to FMVSS 124 providing no alterations are made which affect the function, physical or mechanical properties, environment, location or vital spatial clearances of the components, assemblies or systems identified below:

Accelerator control systems, including but not limited to:

- Lever, throttle or accelerator and supporting bracket
- Cable or rod, throttle or accelerator and support bracket including seals
- Electronic throttle control assembly and related wiring
- Cruise control module, wiring and cable (if so equipped)
- Spring(s)-throttle or accelerator return
- Pedal-throttle or accelerator and attachments
- Floor covering material must not be installed under pedal nor within 1 inch of side of pedal
- Attachment pin, hole or ball stud to carburetor/port fuel injection unit throttle lever

FMVSS 201 – Occupant Protection in Interior Impacts (GVWR of 10,000 Pounds or Less)

A The following statement is applicable to Chassis Cab and Cutaway Van (unless otherwise noted on the cover of this document).

This incomplete vehicle, when completed, will conform to FMVSS 201 providing no alterations are made which affect the function, physical or mechanical properties, environment, location or vital spatial clearances of the components, assemblies or systems identified below:

- | | |
|----------------------------|---------------------|
| Instrument panel | Headliner |
| Seats | Upper interior trim |
| Interior compartment doors | |
| Sunvisors | |
| Arm rests | |

FMVSS 202 – Head Restraints (GVWR of 10,000 Pounds or Less)

- A The following statement is applicable to Chassis Cab, Cutaway Van, Van, Suburban, Pickup and Blazer/Yukon (unless otherwise noted on the cover of this document).**

This incomplete vehicle, when completed, will conform to FMVSS 202 providing no alterations or substitutions are made to the seat assemblies.

FMVSS 203 – Impact Protection for the Driver from the Steering Control System (GVWR of 10,000 Pounds or Less)

- A The following statement is applicable to Chassis Cab and Cutaway Van (unless otherwise noted on the cover of this document).**

This incomplete vehicle, when completed, will conform to FMVSS 203 providing no alterations are made which affect the function, physical or mechanical properties, elements, location or vital spatial clearances of the components, assemblies or systems identified below:

Instrument Panel
Driver seat assembly

Steering column assembly, including steering wheel

FMVSS 204 – Steering Control Rearward Displacement (GVWR of 10,000 Pounds or Less)

- A The following statement is applicable to Chassis Cab, Van, Suburban and Utility (unless otherwise noted on the cover of this document).**

This incomplete vehicle, when completed, will conform to FMVSS 204 providing no alterations are made to the cab and front end sheet metal and structural components, roof, hood, hood mechanism, doors, fenders, pillars, fender reinforcement, cowl, bumpers and bumper mounting system, frame/frame reinforcement, front suspension and front crossmember or steering control system or other components that would affect the steering control system displacement in a 30 m.p.h. fixed barrier impact.

FMVSS 205 – Glazing Materials

- A The following statement is applicable to Chassis Cab, Van, Cutaway Van, Pickup and Utility (unless otherwise noted on the cover of this document).**

This incomplete vehicle, when completed, will conform to FMVSS 205 providing no alterations are made which affect the physical or chemical properties of the glazing material or the monogram or the visibility of the monogram.

FMVSS 206 – Door Locks and Door Retention Components (Not Applicable to Bus)

A The following statement is applicable to Cutaway Van, Van and Chassis Cab (unless otherwise noted on the cover of this document).

This incomplete vehicle, when completed, will conform to FMVSS 206 providing no alterations are made which affect the function, physical or mechanical properties, environment, location or vital spatial clearances of the components, assemblies or systems identified below:

Door and pillar systems, including but not limited to:

- Door lock
- Inside lock control linkage
- Door latch
- Door wedges
- Door latch striker plate
- Door hinge
- Exterior door handles

FMVSS 207 – Seating Systems

A The following statement is applicable to Chassis Cab and Cutaway Van (unless otherwise noted on the cover of this document).

This incomplete vehicle, when completed, will conform to FMVSS 207 providing no alterations are made which affect the function, physical or mechanical properties, environment, location and vital spatial clearances of the components, assemblies or systems provided and identified below:

Seating systems, including but not limited to:

- Seat assembly
- Folding seat or seat back latch assembly
- Seat or seat back latch striker
- Seat riser
- Seat adjuster assembly
- Seat or seat back latch assembly
- Seat or seat back latch release control
- Seat anchorages brackets, reinforcements, attachment hardware, etc.

If the intermediate or final stage manufacturer installs any additional seats, they will also have to meet the requirements of this standard.

FMVSS 208 – Occupant Crash Protection

- A The following statement is applicable to the vehicles having an unloaded vehicle weight of more than 5500 pounds or a GVWR greater than 8500 pounds.**

This incomplete vehicle, when completed, will conform to FMVSS 208 providing no alterations are made to the number, location or configuration of the designated seats/seating positions or to the number, placement, installation or model number of the seat belt assemblies of this incomplete vehicle.

- B The following statement is applicable to vehicles having an unloaded vehicle weight of 5500 pounds or less and a GVWR of 8500 pounds or less but without AQ8, VK5, YF7, 8E2, and to G31706 Vans with seating arrangement RPO ZX2.**

This incomplete vehicle, when completed, will conform to FMVSS 208 providing it is completed in accordance with the following specific conditions by the final stage manufacturer:

1. The front seat belts provided by General Motors will conform to the requirements of FMVSS 208, providing no alterations are made to:
 - a. the number, location or configuration of the designated seating positions; and
 - b. the number, placement, installation or model number of the seat belt assemblies provided; and
 - c. the instrument panel or its mounting, the steering column/shaft or its mounting, the knee bolster or its mounting, the steering wheel, horn pad, driver air bag module or its mounting and covering, passenger air bag module or its mounting or covering (if so equipped), air bag crash sensors, Sensor Diagnostic Module (SDM) in C/K, M/L and G Vans, and all air bag system wiring. Do not relocate or move the SDM.

Do not obstruct the path of air bag deployment. (See restricted area reference in appendix.)

Do not mount any components that produce more than a 20 Gauss magnetic field as measured at the SDM. Speakers/*magnets* must be located at least 5 inches from the SDM.

You must disconnect the SDM before doing any welding on the vehicle, otherwise do not disconnect the SDM.

(FMVSS 208 – continued from previous page)

If the sunshade is removed or altered, a new Inflatable Restraints System Caution label must be installed per the sketch found in Part III of this document. A label has been shipped loose. In order to be in compliance with FMVSS 208 no other label shall be installed on the same side of the sunvisor as the Inflatable Restraint Caution (Air Bag) label. Instrument panel temporary warning label must not be removed.

NOTE: All air bag components have yellow connectors.

CAUTION: To help avoid Personal Injury Due to unwanted air bag inflation, observe the following precautions!

Do not weld, solder, braze, hammer, machine, drill, heat, electrical splice, add onto, remove, relocate, test, paint, loosen or in any way alter air bag components or wiring or fuses. Carpet may be put over the SDM if an appropriate moisture barrier (such as a rubber matted backing) is supplied.

When performing any operation around air bag components or wiring including but not limited to any operations around the instrument panel, electrical wiring and fuse block, steering column/wheel, and the engine compartment you must disable the air bag system prior to the operation. If the vehicle is equipped with an SDM, you must disable the air bag system prior to upfitting. *Note: Striking or dropping a powered SDM may cause air bag deployment.* The air bag system must be enabled after operation completion. This must be verified before shipping the vehicle. Instructions for disabling and enabling the air bag system can be found in the GM service manual for the specific product line.

- d. the vehicle frame, front bumper system, front sheet metal or other front structure, roof structure, doors, floor pan, driveline or contents of the engine compartment by any subsequent manufacturer which would result in any difference from the modified vehicle's deceleration if the modified vehicle were to be subjected to barrier impact tests conducted per FMVSS 208.
2. The rear seat belts provided by General Motors will conform to FMVSS 208 providing no alterations are made to the number, location or configuration of the designated seats/seating positions or to the number, placement, installation or model number of the seat belt assemblies of this incomplete vehicle.

FMVSS 209 – Seat Belt Assemblies

- A The following statement is applicable to Chassis Cab, G or M/L05 Vans (unless otherwise noted on the cover of this document).**

This incomplete vehicle, when completed, will conform to FMVSS 209 providing no alterations or substitutions are made to the seat belt assemblies, attachment hardware, Owner's Manual Instructions or seats provided. For vehicles having GVWR of 8500 pounds or less, the vehicle model number as shown on the label on the cover of this document must be included on the final stage manufacturer's certification label.

FMVSS 210 – Seat Belt Assembly Anchorages

- A The following statement is applicable to Chassis Cab, G05 or M/L05 Vans (unless otherwise noted on the cover of this document).**

This incomplete vehicle, when completed, will conform to FMVSS 210 providing no additional occupant seats or seat belt assembly anchorages are added and no alterations are made which affect the function, physical or mechanical properties, environment, location or vital spatial clearances of the components, assemblies or systems identified below:

Seat belt systems, including but not limited to:

- Seat assemblies
- Floor pan assembly
- Seat belt routing
- Seat belt assemblies
- Seat position/adjustment capability
- Seat belt anchorage brackets/reinforcements
- Child restraining Anchorage

FMVSS 212 – Windshield Mounting (GVWR of 10,000 Pounds or Less)

A This Chassis Cab or Van, when completed, will conform to FMVSS 212 if:

1. No alterations are made to the cab and front end structural components including roof, hood and hood mechanism, doors, fenders, pillars, fender reinforcement, cowl, bumpers and bumper mounting system, windshield and windshield mounting system and frame/frame reinforcement.
2. The maximum weight of the body and/or equipment installed must be such that the completed vehicle's unloaded vehicle weight does not exceed the values specified in Table "A", as applicable.
3. The center of gravity for the respective body type of the installed body and accessories does not exceed the maximum center of gravity height specified in Table "A".
4. The height above the frame of the body or accessories does not exceed the maximum body height specified in Table "A".
5. The clearance between the rear most part of the cab and the front of the body is not less than the minimum cab to body clearance specified in Table "A".
6. The minimum vertical clearance between the cab roof and any portion of the installed body or accessories that extends over the cab roof must not be less than eight inches.
7. The maximum body weight does not exceed the value specified in Table "A".
8. During a 30 m.p.h. frontal barrier impact test, no component installed by any subsequent manufacturer shall move forward from its permanently mounted position.

FMVSS 214 – Side Impact Protection (GVWR of 10,000 Pounds or Less – Static) (GVWR of 6,000 Pounds or Less – Dynamic)

- A The following statement is applicable to Chassis Cab, Van, Suburban, Pickup and Utility (unless otherwise noted on the cover of this document).**

This incomplete vehicle, when completed, will conform to FMVSS 214 providing no alterations are made to the cab, roof, floor, side pillars, fuel system, chassis, structural components and door assemblies.

FMVSS 216 – Roof Crush Resistance (GVWR of 6,000 Pounds or Less)

- A The following statement is applicable to M/L Vans, Pickups and Utility with a GVWR of 6000 pounds or less (unless otherwise noted on the cover of this document).**

This incomplete vehicle conforms to FMVSS 216 providing no alterations are made to the cab, roof, side pillar, structural components and door assemblies.

FMVSS 219 – Windshield Zone Intrusion (GVWR of 10,000 Pounds or Less)

- A The following statement is applicable to Chassis Cab (unless otherwise noted on the cover of this document).**

This incomplete vehicle, when completed, will conform to FMVSS 219 providing: no alterations are made to the cab and front end structural components, the hood and hood mounts; the vehicle does not exceed the Chassis Cab unloaded vehicle weight specified in Table “A”; and during a 30 m.p.h. frontal barrier impact test: (1) no component installed by any manufacturer shall prevent the hood from folding upward along the lateral centerline; and (2) no component installed by any manufacturer shall penetrate the windshield or protected zone.

Not applicable to walk-in vans, motor homes, tow trucks, ambulance, and other emergency/rescue/medical vehicles to those equipped for wheelchairs.

FMVSS 301 – Fuel System Integrity MPV’S, Trucks and Buses (GVWR of 10,000 Pounds or Less)

A The following statement is applicable to Chassis Cab and Van (unless otherwise noted on the cover of this document).

This incomplete vehicle, when completed, will conform to FMVSS 301 providing it is completed in accordance with the following specific conditions by the final stage manufacturer:

1. The following items when installed by General Motors will conform providing no alterations are made which affect the function, physical or mechanical properties, environment, location or vital spatial clearances of the components, assemblies or systems identified below:

- Fuel feed pipes – front, rear and intermediate
- Fuel return pipes – front and rear
- Fuel feed and return hose – front rear and intermediate
- Fuel tank assembly
- Fuel vapor lines and cannister
- Fuel tank meter assembly
- Fuel tank shields/cage
- Fuel tank filler neck plate
- Fuel tank cap assembly

- Fuel tank filler neck screws
- Fuel tank filler neck hose
- Fuel tank filler neck vent hose
- Fuel tank filler neck vent hose clamp/strap
- Fuel tank filler neck hose clamp/clamp assembly
- Fuel tank filler neck assembly upper
- Fuel filter
- Fuel hose shield

2. This incomplete vehicle, when completed, will conform to FMVSS 301 Fuel System Integrity if:
 - a. No alterations are made to the fuel system and attaching or protective structure.
 - b. The unloaded cab chassis vehicle weight of the completed vehicle does not exceed the weight listed in Table “A” as applicable.
 - c. Any subsequent manufacturer completes the fuel filler neck installation according to the instructions available in the current year’s Body Builders’ Book.
 - d. During all barrier impact tests:
 - i. No component installed by any subsequent manufacturer impinges or causes distortion to the fuel system with sufficient energy to puncture or separate the fuel system.
 - ii. No vehicle modification by any subsequent manufacturer results in any portion of the vehicle impinging upon or causing distortion to the fuel system with sufficient energy to puncture or separate the fuel system. Care should be taken that the structural integrity of the vehicle is restored following any modification of the structure.

SPECIAL APPLICATIONS

2004 C/K Pickup Box Removal Program – TABLE A

Model	General Body Type	Maximum Body Center of Gravity Height (inches)	Maximum Body Height (inches)	Minimum Cab to Body Clearance (inches)	Maximum Unloaded Vehicle Weight with Service Body (lbs)	Maximum Body Weight (lbs)
C15903 – Regular Cab 6,400 LB GVWR 133.0" WB / 55.9" CA	Low Service	14.0 above the frame	Under 62.0	3	5,343	1,100
K15903 – Regular Cab 6,400 LB GVWR 133.0" WB / 55.9" CA	Low Service	14.0 above the frame	Under 62.0	3	5,660	1,100
** C15753 – Extended Cab 6,200 LB GVWR 143.5" WB / 42.0" CA	Low Service	14.0 above the frame	Under 62.0	3	5,495	1,100
** K15753 – Extended Cab 6,400 LB GVWR 143.5" WB / 42.0" CA	Low Service	14.0 above the frame	Under 62.0	3	5,744	1,100
C15743HD – Crew Cab 8,600 LB GVWR 153.0" WB / 42.0" CA	Low Service High Service	14.0 above the frame 20.3 above the frame	Under 62.0 62.0 & over	3	6,970 7,470	1,300 1,800
K15743HD– Crew Cab 8,600 LB GVWR 153.0" WB / 42.0" CA	Low Service	14.0 above the frame	Under 62.0	3	7,295	1,300
C25903 – Regular Cab 8,600 LB GVWR 133.0" WB / 55.9" CA	Low Service High Service	14.0 above the frame 20.3 above the frame	Under 62.0 62.0 & over	3	7,179 7,944	1,700 2,600

NOTES: Upfitters completed vehicle weight should not exceed the max. unloaded vehicle weight shown in table A. If weight is exceeded, recertification by upfitter may be required. Max. Body Weight equals Max. Unloaded Vehicle Weight minus Curb Weight without pickup box and bumper. Vehicle Curb Weight can be obtained from label inside driver's door. On Vehicles of 8,500 lb. GVWR or less, see the Vehicle Emission Control Information, Engine Exhaust Emission Control Information or Important Engine Information Label in the vehicle engine compartment for completed vehicle curb weight requirements. Due to ongoing product development these weights are subject to change.

** Not Available with option "NYS" – Quad Steering

PU Box Weights: C/K (15/25)(743/753) = 320 lbs. / C/K (15/25)(903/943/953) = 370 lbs.

Bumpers: C/K = 53 lbs.

SPECIAL APPLICATIONS

2004 C/K Pickup Box Removal Program – TABLE A (Continued)

Model	General Body Type	Maximum Body Center of Gravity Height (inches)	Maximum Body Height (inches)	Minimum Cab to Body Clearance (inches)	Maximum Unloaded Vehicle Weight with Service Body (lbs)	Maximum Body Weight (lbs)
C25903HD – Regular Cab 9,200 LB GVWR 133.0" WB / 55.9" CA	Low Service High Service	14.0 above the frame 20.3 above the frame	Under 62.0 62.0 & over	3	7,272 8,172	1,700 2,600
K25903HD – Regular Cab 9,200 LB GVWR 133.0" WB / 55.9" CA	Low Service	14.0 above the frame	Under 62.0	3	7,552	1,700
C25753HD – Extended Cab 9,200 LB GVWR 143.5" WB / 42.0" CA	Low Service High Service	14.0 above the frame 20.3 above the frame	Under 62.0 62.0 & over	3	7,175 7,675	1,300 1,800
K25753 – Extended Cab 8,600 LB GVWR 143.5" WB / 42.0" CA	Low Service	14.0 above the frame	Under 62.0	3	6,670	1,300
K25753HD – Extended Cab 9,200 LB GVWR 143.5" WB / 42.0" CA	Low Service	14.0 above the frame	Under 62.0	3	7,385	1,300
C25743HD – Crew Cab 9,200 LB GVWR 153.0" WB / 42.0" CA	Low Service High Service	14.0 above the frame 20.3 above the frame	Under 62.0 62.0 & over	3	7,448 7,948	1,300 1,800
K25743HD – Crew Cab 9,200 LB GVWR 153.0" WB / 42.0" CA	Low Service	14.0 above the frame	Under 62.0	3	7,773	1,300

NOTES: Upfitters completed vehicle weight should not exceed the max. unloaded vehicle weight shown in table A. If weight is exceeded, recertification by upfitter may be required. Max. Body Weight equals Max. Unloaded Vehicle Weight minus Curb Weight without pickup box and bumper. Vehicle Curb Weight can be obtained from label inside driver's door. On Vehicles of 8,500 lb. GVWR or less, see the Vehicle Emission Control Information, Engine Exhaust Emission Control Information or Important Engine Information Label in the vehicle engine compartment for completed vehicle curb weight requirements. Due to ongoing product development these weights are subject to change.

** Not Available with option "NYS" – Quad Steering

PU Box Weights: C/K (15/25)(743/753) = 320 lbs. / C/K (15/25)(903/943/953) = 370 lbs.

Bumpers: C/K = 53 lbs.

SPECIAL APPLICATIONS

2004 C/K Pickup Box Removal Program – TABLE A (Continued)

Model	General Body Type	Maximum Body Center of Gravity Height (inches)	Maximum Body Height (inches)	Minimum Cab to Body Clearance (inches)	Maximum Unloaded Vehicle Weight with Service Body (lbs)	Maximum Body Weight (lbs)
C25953HD – Extended Cab 9,200 LB GVWR 157.5" WB / 55.9" CA	Low Service High Service	14.0 above the frame 20.3 above the frame	Under 62.0 62.0 & over	3	7,696 8,544	1,700 2,600
K25953HD – Extended Cab 9,200 LB GVWR 157.5" WB / 55.9" CA	Low Service	14.0 above the frame	Under 62.0	3	7,921	1,700
C25943HD – Crew Cab 9,200 LB GVWR 167.0" WB / 55.9" CA	Low Service High Service	14.0 above the frame 20.3 above the frame	Under 62.0 62.0 & over	3	7,959 8,544	1,700 2,600
K25943HD – Crew Cab 9,200 LB GVWR 167.0" WB / 55.9" CA	Low Service	14.0 above the frame	Under 62.0	3	8,298	1,700
K35903 – Regular Cab 9,900 LB GVWR 133.0" WB / 55.9" CA	Low Service	14.0 above the frame	Under 62.0	3	7,791	1,700
K35953 – Extended Cab 9,900 LB GVWR 157.5" WB / 55.9" CA	Low Service	14.0 above the frame	Under 62.0	3	8,199	1,700
K35943 – Crew Cab 9,900 LB GVWR 167.0" WB / 55.9" CA	Low Service	14.0 above the frame	Under 62.0	3	8,387	1,700

NOTES: Upfitters completed vehicle weight should not exceed the max. unloaded vehicle weight shown in table A. If weight is exceeded, recertification by upfitter may be required. Max. Body Weight equals Max. Unloaded Vehicle Weight minus Curb Weight without pickup box and bumper. Vehicle Curb Weight can be obtained from label inside driver's door. On Vehicles of 8,500 lb. GVWR or less, see the Vehicle Emission Control Information, Engine Exhaust Emission Control Information or Important Engine Information Label in the vehicle engine compartment for completed vehicle curb weight requirements. Due to ongoing product development these weights are subject to change.

** Not Available with option "NYS" – Quad Steering

PU Box Weights: C/K (15/25)(743/753) = 320 lbs. / C/K (15/25)(903/943/953) = 370 lbs.

Bumpers: C/K = 53 lbs.

FMVSS 302 – Flammability of Interior Materials

A The following statement is applicable to Chassis Cab, Van, Suburban, Pickup and Utility (unless otherwise noted on the cover of this document).

This incomplete vehicle, when completed, will conform to FMVSS 302 providing no alterations or substitutions are made which affect any materials, parts or components identified below and installed on the vehicle by General Motors:

- | | |
|---------------------|---|
| Seat cushions | Sunvisors |
| Seat backs | Curtains |
| Seat belts | Shades |
| Headlining | Wheel housing covers |
| Arm rests | Head restraints |
| Floor covering | Engine compartment covers |
| Console | Instrument panel |
| Compartment shelves | All trim panels including door, front, rear and side panels |
- Any other interior materials, including padding and crash deployed elements that are designed to absorb energy on contact by occupants in the event of a crash

Canada Motor Vehicle Safety Standards

CMVSS NO.	TITLE	CHASSIS CAB	CUTAWAY VAN
1101	Emission device.....	A	A
1102	Crankcase emission	A	A
1103	Exhaust emission	A	A
1104	Opacity (Diesel engine only)	A	A
1105	Evaporate emissions (Vehicles 6,000 lbs. GVW or less).....	A	A
1106	Noise	A	A
108	Lighting equipment (Daytime running lamps).....	A	A

CANADA RADIO INTERFERENCE REGULATION

Radio Noise	A	—	A
-------------------	---	---	---

STATEMENTS REGARDING CANADA MOTOR VEHICLE SAFETY STANDARDS

C The following statement is applicable to all three basic types of incomplete vehicles (unless otherwise noted on the cover of this document).

This incomplete vehicle, when completed, will conform to the above standards except CMVSS 1106 providing no alterations are made which affect the function, physical or mechanical properties, environment, locations or vital spatial clearances of the components identified below:

- | | |
|--|--------------------------------------|
| * Engine assembly | Fuel system |
| * Carburetor/T.B.I. and choke controls | Evaporative emission control system |
| * Ignition system | * Transmission assembly |
| * A.I.R. system | * Axle |
| Exhaust emission control system | * Tires |
| P.C.V. system | * Fan and drive |
| * Intake system | * Diesel fuel injection controls |
| * Exhaust system | Turbocharger and associated controls |
| * Catalytic converter | * Noise shields/insulation |

Conformity with CMVSS 1106 is not determined solely by the design of this incomplete vehicle. Providing no alterations are made to the noise attenuation components identified thus * in the above list, the capability exists to certify the vehicle with the chassis components provided by General Motors.

CMVSS 108 – Lighting Equipment (*Daytime Running Lamps*)

A The following statement is applicable to all three basic types of incomplete vehicles (unless otherwise noted on the cover of this document).

This incomplete vehicle, when completed, will conform to the Daytime Running Lamps requirements of CMVSS 108, providing no alterations are made to the ignition switch, system wiring or forward, park or turn lamps.

Radio Noise Interference

A The following statement is applicable to all three basic types of incomplete vehicles (unless otherwise noted on the cover of this document).

This incomplete vehicle, when completed, will conform to the above regulations providing no alterations or substitutions are made which affect any parts of components identified below:

VCM/PCM

Ignition wires & plugs

Spark plug wires

Ignition coil(s)

U.S. EPA and California Exhaust and Evaporative Emission Requirements **and NHTSA Fuel Economy Regulations**

Incomplete vehicles come in three major classifications: (1) Light Duty trucks (Light and Medium Duty in California) are certified by the primary manufacturer and the vehicle is labeled as being in compliance with emission and fuel economy requirements. (2) Heavy Duty Vehicles are required to have an engine certified by the engine manufacturer and the engine is labeled as being in compliance with emission requirements. (3) Light Duty Vehicles certified and labeled by the final stage manufacturer as being in compliance with emission and fuel economy requirements.

In addition, all gasoline powered Federal/California Light Duty, Medium Duty and Heavy Duty Vehicles are required to have an approved fuel evaporative emission control system. Vehicles certified to Heavy Duty emission standards also require special evaporative emission labeling. In order to assure that Environmental Protection Agency (EPA), National Highway Traffic Safety Administration (NHTSA), and California Emission Certification and/or Fuel Economy regulations are met, this vehicle must be completed in strict accordance with all instructions contained in this manual, especially the following instructions which relate to:

- A Vehicle Curb Weight, Frontal Area* and Gross Vehicle Weight**
- B Emission Related Components**
- C Specifications for Fill Pipes and Opening of Motor Vehicle Fuel Tanks**
- D Labels**

* Frontal area is measured utilizing procedures described in Mobile Source Air Pollution Control Advisory Circular No. 73 available from the U.S. Environmental Protection Agency.

SPECIAL APPLICATIONS

A VEHICLE CURB WEIGHT AND FRONTAL AREA (APPLICABLE ONLY TO VEHICLES OF 8,500 POUNDS GVWR OR LESS)

1. **Heavy Duty Vehicles (8,500 pounds GVWR or less)** – To enable compliance with Heavy Duty emission regulations, completed vehicles equipped with powertrains indicated *must exceed* curb weights or frontal areas shown below:

G31303

6.5L V8 Diesel	(L65)	All	6,000	45.0 sq. ft.
----------------	-------	-----	-------	--------------

The permissible unloaded curb weight and frontal area of this vehicle is specified on the Important Engine Information Label which is permanently affixed in the engine compartment of the vehicle conveys this information to the final stage manufacturer. To insure compliance with EPA requirements, the final stage manufacturer is responsible for insuring that the permissible unloaded curb weight and frontal area requirement is adhered to in the finished vehicle.

Note: Vehicles certified to *Heavy Duty* emission regulations and having a GVWR greater than 8,500 pounds have no specific completed vehicle curb weight or frontal area limitations dictated by emission certification requirements.

B EMISSION RELATED COMPONENTS

1. All vehicles.

Further compliance of this vehicle with EPA and/or California Emission Certification requirements will be maintained providing no alterations (except where noted) are made to the components identified below:

Engine assembly	EGR system
Ignition system	Fuel system
Exhaust emission control system	* Transmission assembly
Crankcase emission control system	* Axle ratio
** Evaporative emission control system	* Tires
Air inlet system	Diesel fuel injection controls
Exhaust system	Turbocharger and associated controls
Catalytic converter	Electronic closed loop carburetor system
TBI unit	Engine electronics (vcm/pcm)
Electronic closed loop TBI system	Exhaust oxygen sensors

* Applicable only to Light Duty Trucks.

- ** All Federal/California gasoline powered heavy duty vehicles will have an evaporative emission control system that is certified for a fuel tank capacity not to exceed the amount shown on the Vehicle Evaporative Emission Control Information Label located on the air cleaner (P30), the radiator support bracket (C6, C7, P12) and on the fan shroud (C/K 2500, 3500, G Van). Persons wishing to add fuel tank capacity above the amount shown must contact California Air Resources Board and/or submit a written statement to the EPA Administrator that the Hydrocarbon Storage System has been upgraded according to the requirements of 40 CFR 86.088-35 (g) (2).

In addition, compliance with applicable fuel evaporative emission regulations will be maintained if no alterations are made to the fuel filler neck(s) and any subsequent manufacturer completes the fuel filler neck installation(s) and fuel level sender installation(s) where applicable according to the instructions which are furnished in the loose parts box and also available in the current year's Body Builders' Book.

Compliance with applicable fuel evaporative emission regulations will be maintained if no alterations are made to change material or increase the size or length, of the following nonmetallic fuel and evaporative emission hoses.

- Fuel feed hoses front and rear
- Fuel return hoses front and rear
- Fuel tank filler hoses to filler neck
- Fuel tank vent hoses to filler neck
- Fuel vapor lines at cannister
- Fuel vapor lines from engine to chassis pipes
- Fuel vapor lines from fuel tank sender to chassis pipes

2. The following is applicable to models C6H042, C7H042 and C7H064 with gasoline engines and option NJ2-Temporary Fuel Tank which will be converted for use with alternative fuels.

Compliance with applicable exhaust and evaporative emission requirements is the responsibility of the final stage manufacturer. General Motors makes no representation as to the conformity with applicable exhaust and evaporative emission requirements.

C SPECIFICATIONS FOR FILL PIPES AND OPENINGS OF MOTOR VEHICLE FUEL TANKS (APPLICABLE ONLY TO CALIFORNIA GASOLINE POWERED VEHICLES)

This incomplete vehicle, when completed, will conform to Title 13, California Administrative Code Chapter 3 Air Resources Board Subchapter 7, "Specifications for Fill Pipes and Openings of Motor Vehicle Fuel Tanks," if no alterations are made to the fuel filler neck(s) and any subsequent manufacturer completes the fuel filler neck installation(s) according to the instructions which are furnished in the loose parts box and also available in the current year's Body Builders' Book.

Pickup Box Removal Fuel Fill System Modifications for Gasoline Vehicles

Certain guidelines must be adhered to in modifying the fuel fill and vent system to ensure that the completed product meets the manufacturer's requirements.

1. The fuel fill and vent system must be installed such that there is adequate clearance between the fuel fill vent system and the tires under all operating conditions. Body attachment brackets must also be located such that there is adequate clearance to all fuel system components, such as the fuel lines and the fuel level sending unit, under all operating conditions.
2. The fuel fill/vent pipe system available from the dealer includes a number of additional hose retaining beads. The pipe can be trimmed at the hose retaining beads to adjust for the various chassis lengths and body widths. The pipes must be trimmed only at locations where a hose retaining bead is present. A hose retaining bead must be present at each pipe to hose interface in a modified fuel fill and vent system. Pipe ends must be free of burrs which may be detrimental to satisfactory assembly and/or function.
3. A minimum of 8.0 inches of fill hose must be maintained between the filler neck and the fuel tank as measured in an outboard direction from the tank surface (at the fill hose nipple) to the outlet end of the filler neck.
4. Both the fill and the vent hoses must be routed (and supported, if needed) such that there are no sags or kinks. Excess hose length may be removed as required provided hose does not kink. As viewed from the filler neck, pipes and hoses must have a downward slope toward the tank. There should be a minimum of 4° of downward slope in the fill and vent pipes at any location.
5. The fuel fill and vent system should be restrained in the upfit vehicle. This is necessary to avoid chaffing, fretting, rubbing, etc. which may cause wear to the pipes or hoses.
6. Fuel fill hose clamps are to be tightened to 22 lb.-in. torque.
7. Fuel vent hose clamps are to be tightened to 16 lb.-in. torque.
8. Route the rear axle vent hose using the clips on the frame and the bracket on the fuel filler neck assembly.

The parts required to replace the existing fuel fill system (ZW9 for the C/K Pickup) are:

- Pipe Assembly – Fuel Tank / Filler Part Numbers:
15113986 (gas 2004);
15008137 (diesel 2003 & 2004 Start of Production thru December); and
15113971 (diesel 2004I [interim] – January 2004)

Fuel Tank Filler Neck Assembly (Gas - 15113986)



Fuel Tank Filler Neck Assembly (Diesel)

15008137 (Diesel 2003 & 2004 Start of Production thru December)

15113971 (Diesel 2004I [interim] - January 2004)

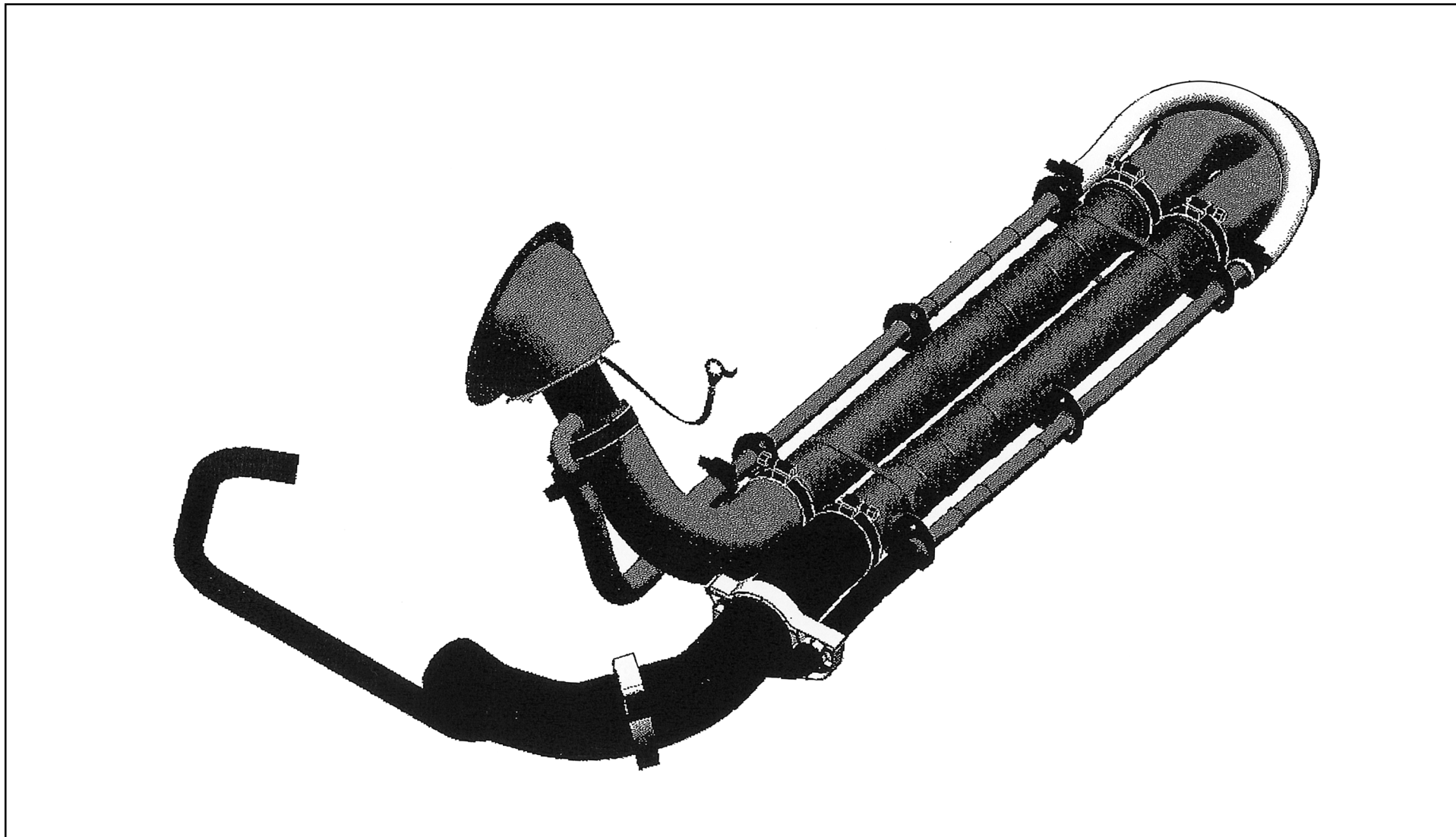

Fuel Filler Pipe Assembly to Frame - Chassis Cab (ZW9) Trucks

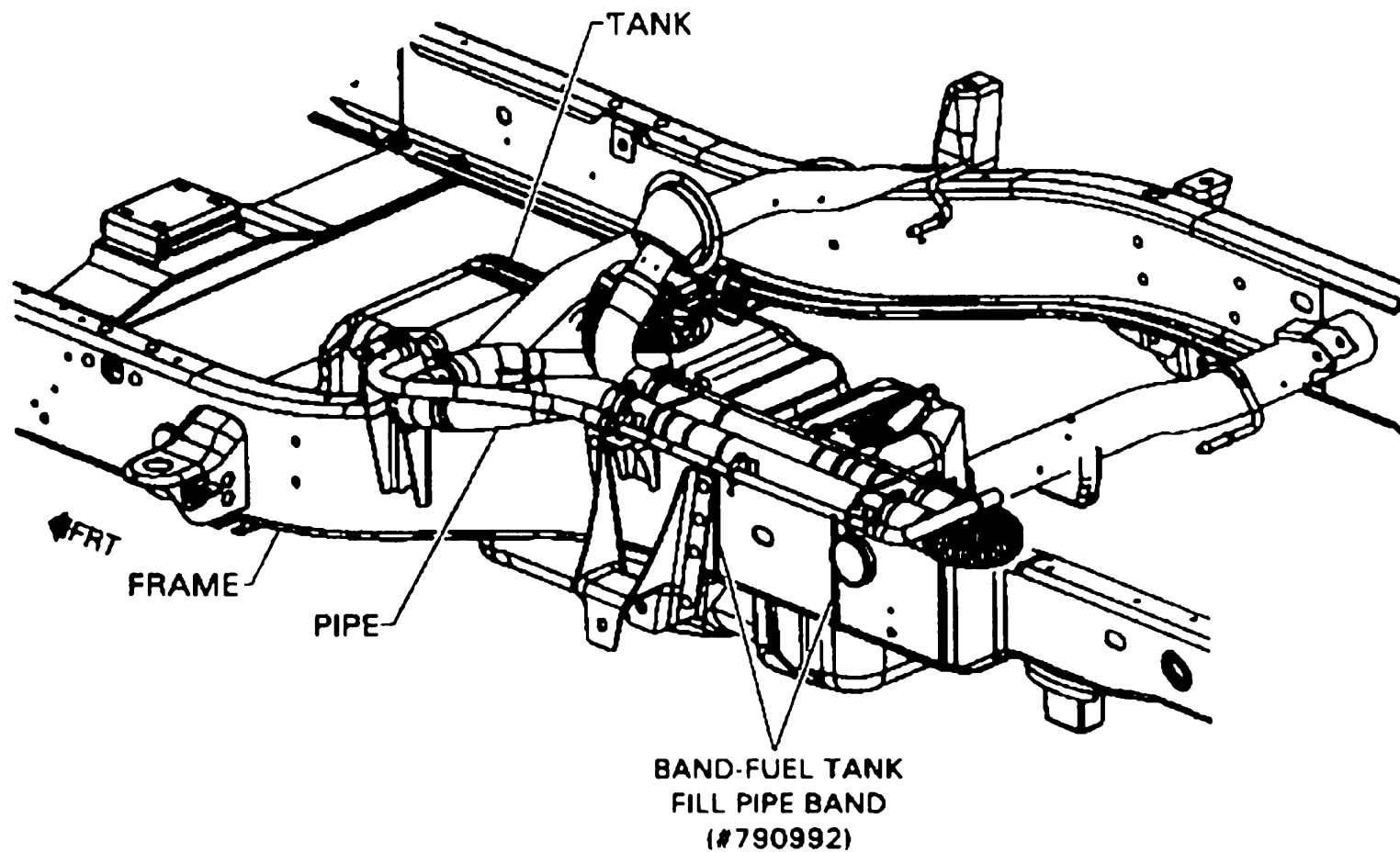

INSTALL FUEL FILL PIPE TO
LH FRAME RAIL WITH (Z) STRAP

Fuel Filler Pipe Assembly to Frame – Pickups Without (ZW9)

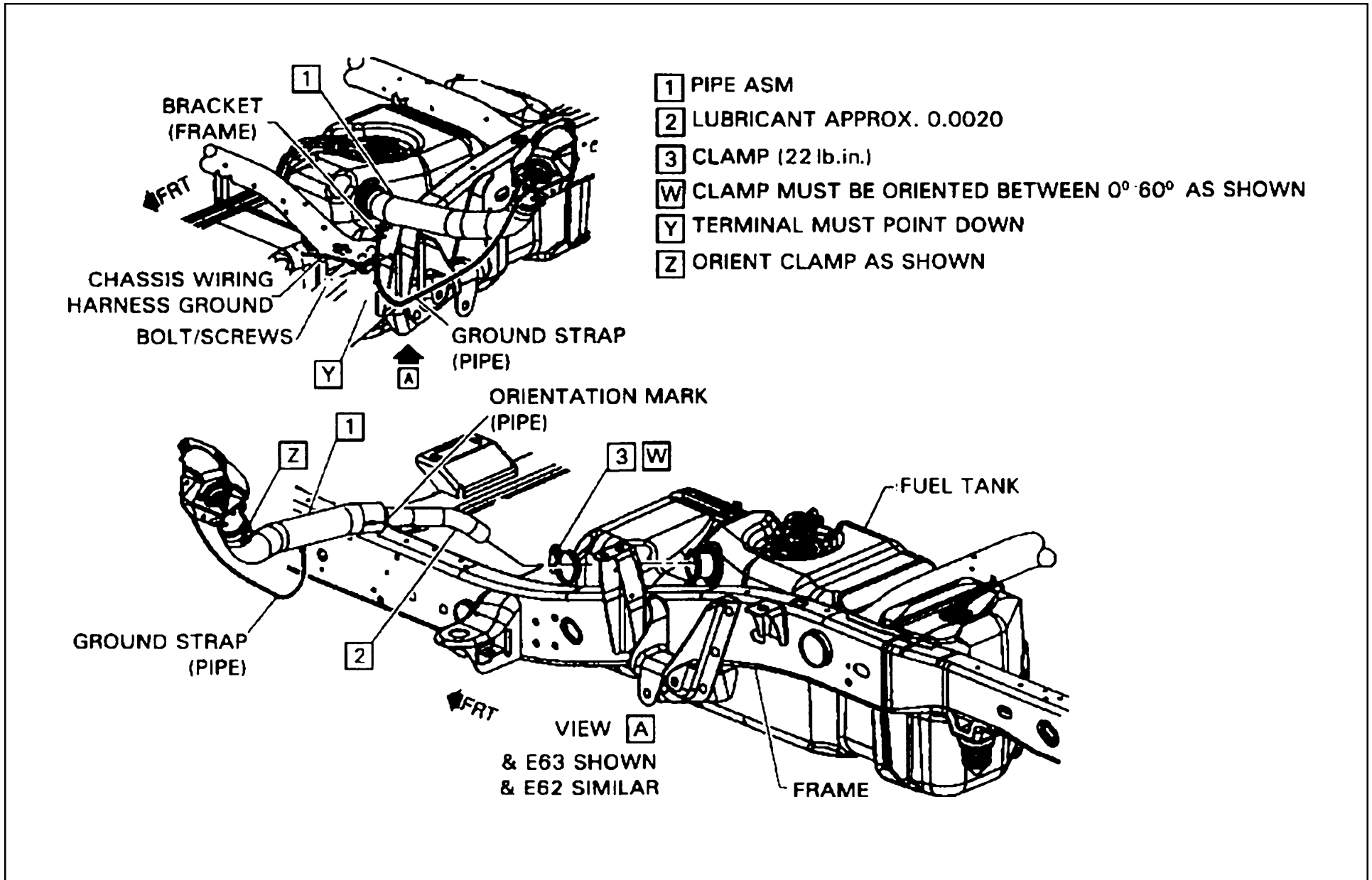

Fuel Filler Pipe Assembly to Frame – Rear Axle Vent Hose (ZW9)

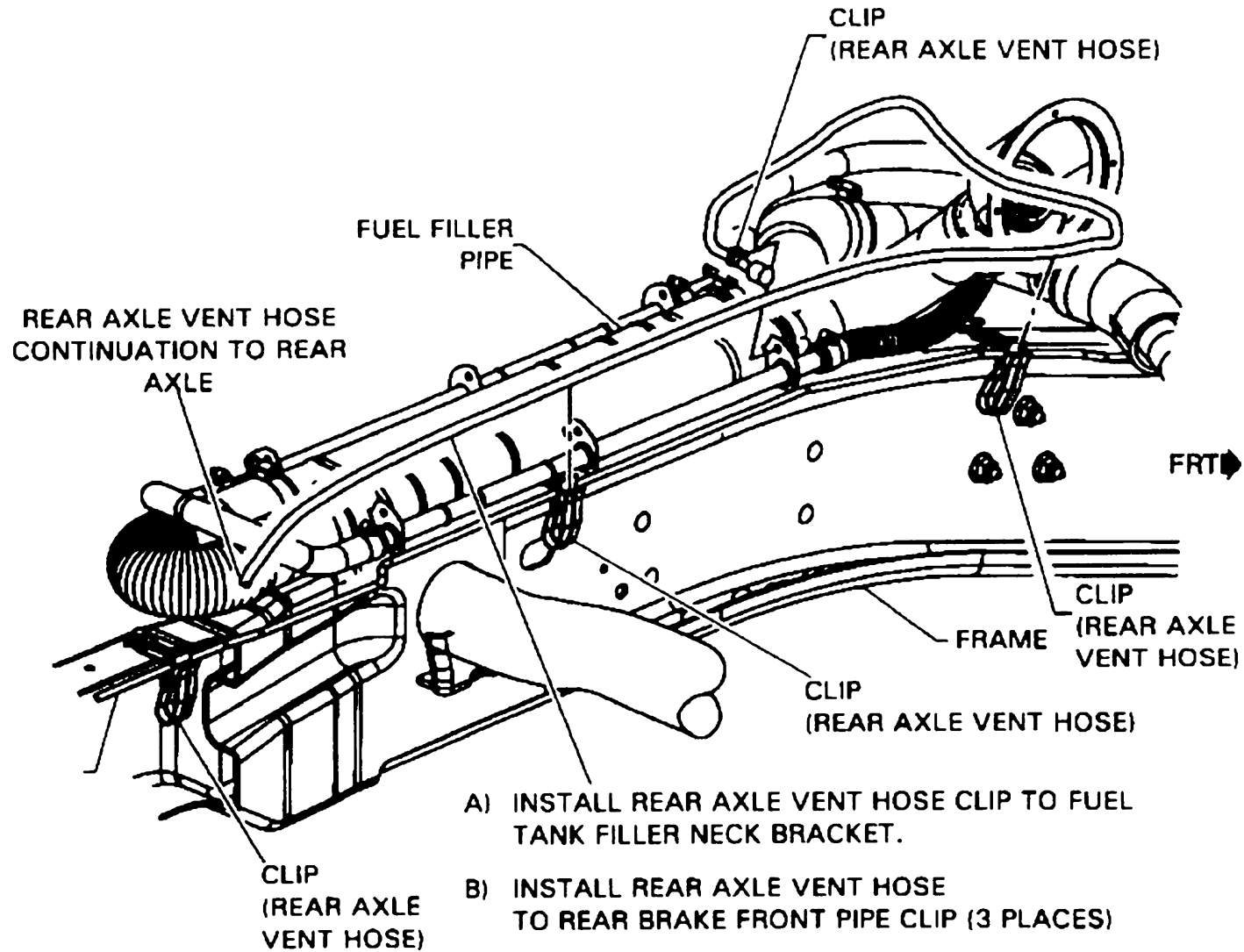

Fuel Filler Pipe Assembly to Frame – Rear Axle Vent Hose (ZW9)

- Z** SECURE VENT HOSE CLIP TO BRAKE LINE 10-25MM FORWARD OF BASKET CLIP.
- Y** FOR CONTINUATION OF USE SEE "REAR AXLE VENT HOSE TO REAR AXLE" SHEET 4A1 - 3

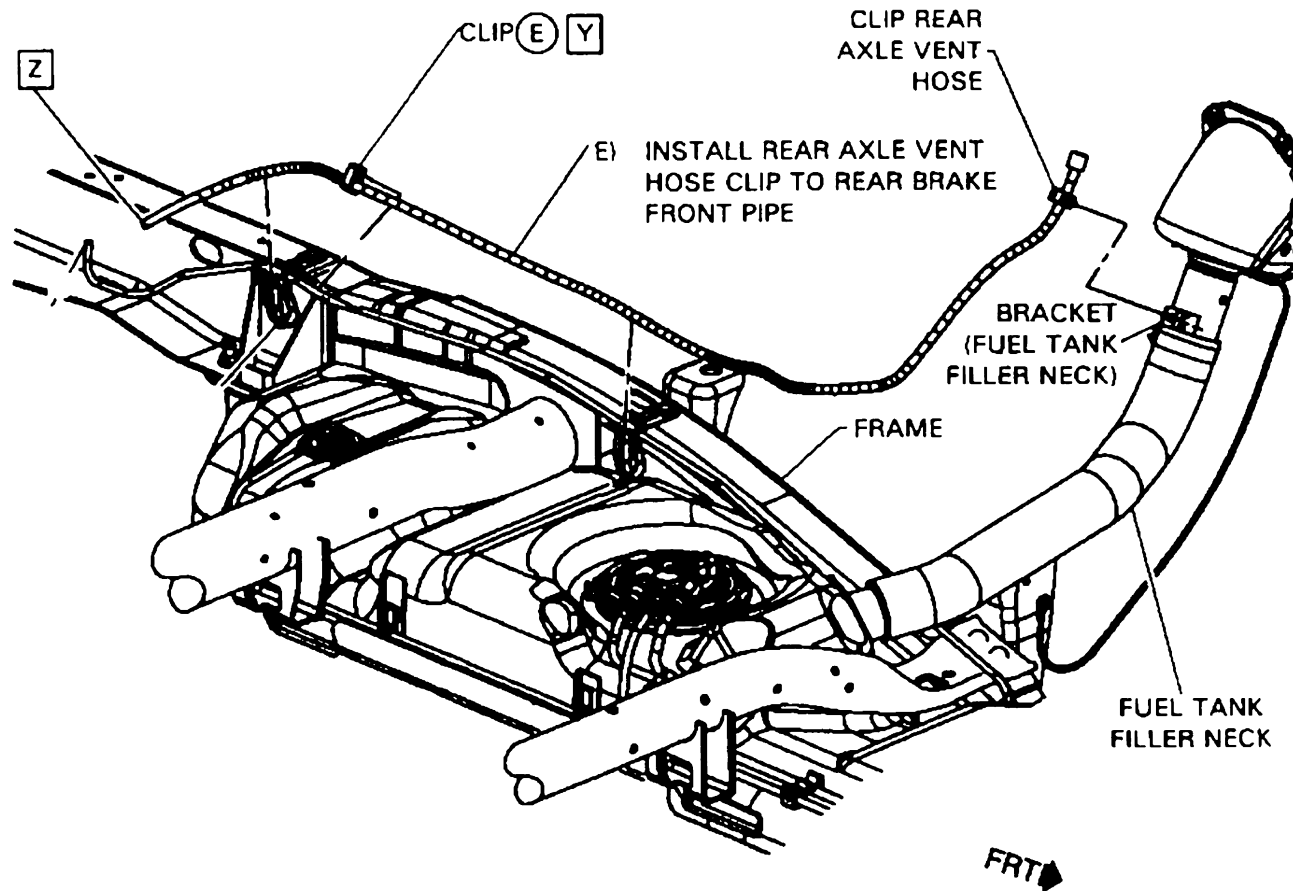

Pickup Box Removal Tail Lamp Wiring Modifications

REAR JUNCTION BLOCK

The tail lamp wiring on the All New C/K is routed to a junction block located at the rear of the vehicle. This junction block interfaces with the rear chassis harness and breaks out the license lamp, left turn lamp and right turn lamp connections (see page 73 for connector face view). A schematic diagram of the Rear Junction Block and tail lamp circuits is shown on page 74. On trucks without the Pickup Box Delete (ZW9) option, this junction block is attached to the underside of the box and therefore must be relocated when removing the box. On trucks with ZW9, this junction block is attached to the left frame rail (see pages 75 & 76).

The parts required to relocate the Rear Junction Block to left frame are as follows:

- | | |
|-----------------------------|--|
| - Junction Block | Part Number: 15304995 |
| - Junction Block Bracket | Part Number: 15031996 |
| - Bolt/Screw (two required) | Part Number: 11516885 (+HVY) 11516588 (-HVY) |

REAR TAIL LAMPS AND LICENSE PLATE LAMP

Trucks originally ordered with the ZW9 option will come equipped with separated function (stop, turn, park, backup) tail lamps which are mounted vertically and attached to the frame rails. These lamps were designed such that they will also comply with the requirements of FMVSS 108 if re-mounted horizontally (and to the FMVSS guidelines) by the upfitter. The license plate lamp assembly will be attached to the left frame rail as shown on page 77. Pages 77 to 81 provide the assembly sequence for the tail lamps and license plate lamp assemblies for trucks built with the ZW9 option.

The parts required to install the rear tail lamps and license plate lamp assembly are as follows:

- | | |
|--------------------------------------|----------------------|
| - Tail Lamp Assembly – LH | Part Number:15029717 |
| - Tail lamp Assembly – RH | Part Number:15029718 |
| - Rear License Plate Lamp Assembly | Part Number:15048278 |
| - Stud/plate Assembly (two required) | Part Number:11588611 |
| - Nut (four required) | Part Number:11516796 |

(Continued on next page)

(Continued from previous page)

COMBINATION LAMPS ON ALL NEW C/K CHASSIS

The All New C/K tail lamp wiring was designed for separated function Stop and Turn lamps, therefore, the tail lamp feeds from the rear junction block cannot be used directly for combination stop/turn lamps. Feeds for combined stop/turn lamps are, however, available off of the trailer tow harness. Trailer wiring is incorporated on all of the All New C/K trucks in one of two forms, Light Duty trailer wiring or Heavy Duty Trailer Wiring. On trucks with Light Duty trailer wiring, the trailer harness is tied back to rear crossmember (see Basic Trailer Wiring Package on page 82). On trucks with Heavy Duty trailer wiring the trailer harness is run to the universal trailer connector at the rear of the vehicle (see Heavy Duty Trailer Wiring Package on page 83).

The Left Stop/Turn Lamp feed can be accessed from the yellow wire (circuit 1618). The Right Stop/Turn Lamp feed can be accessed from the dark green wire (circuit 1619). A schematic diagram of the above mentioned trailer feed circuits is provided on page 84. If using these feeds, the upfitter must consider whether the truck will be used for trailer towing. If so, the upfitter must ensure that the loads of the truck stop/turn lamps combined with the trailer stop/turn lamps do not exceed the capacity of the circuits. Load guidelines for this, as well as splicing guidelines, can be found in the Upfitter Integration Electrical Guideline Manual.

REAR CHASSIS WIRING HARNESS AND REAR LAMP CONNECTOR FACES

A connector face diagram of the Rear Chassis Harness Connector is shown on page 85. As was mentioned above, under the Rear Junction Block heading, the Rear Chassis Harness interfaces with the Rear Junction Block where the rear lamp circuits are broke out. If the upfitter prefers to interface directly with this connector, thus eliminating the Rear Junction Block, an in-line mating connector is available and can be obtained by ordering part number 15326788. Connector faces for the Tail Lamp Connectors and Rear License Plate Lamp Connector are also provided and are shown on pages 86 through 88. Please note that these connectors can either be purchased from a local GM dealer or through Packard by calling 1-800-PACKARD (722-5273).

Rear Junction Block as Viewed from Rear of Vehicle with ZW9

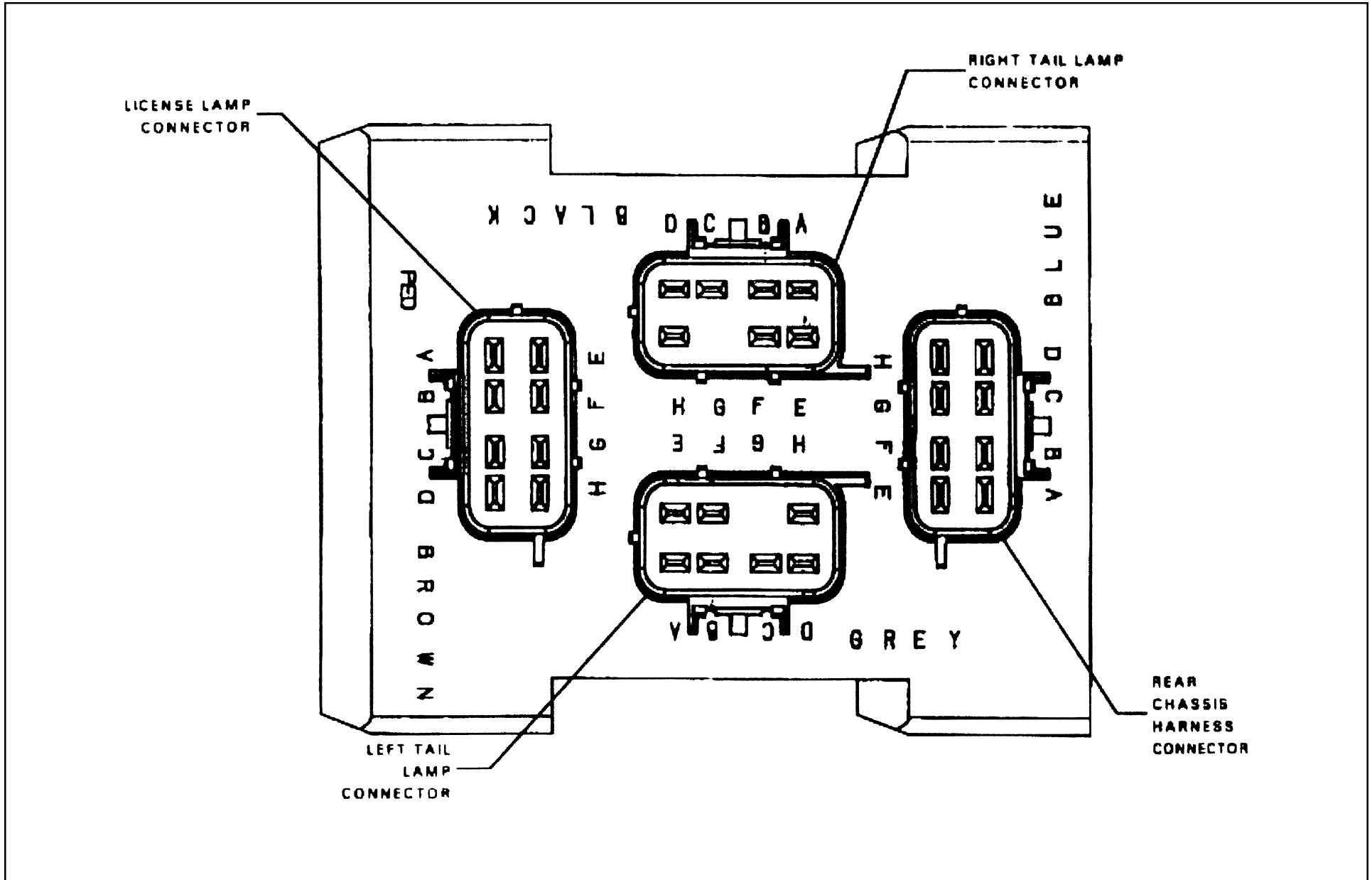

Rear Junction Block Electrical Diagram

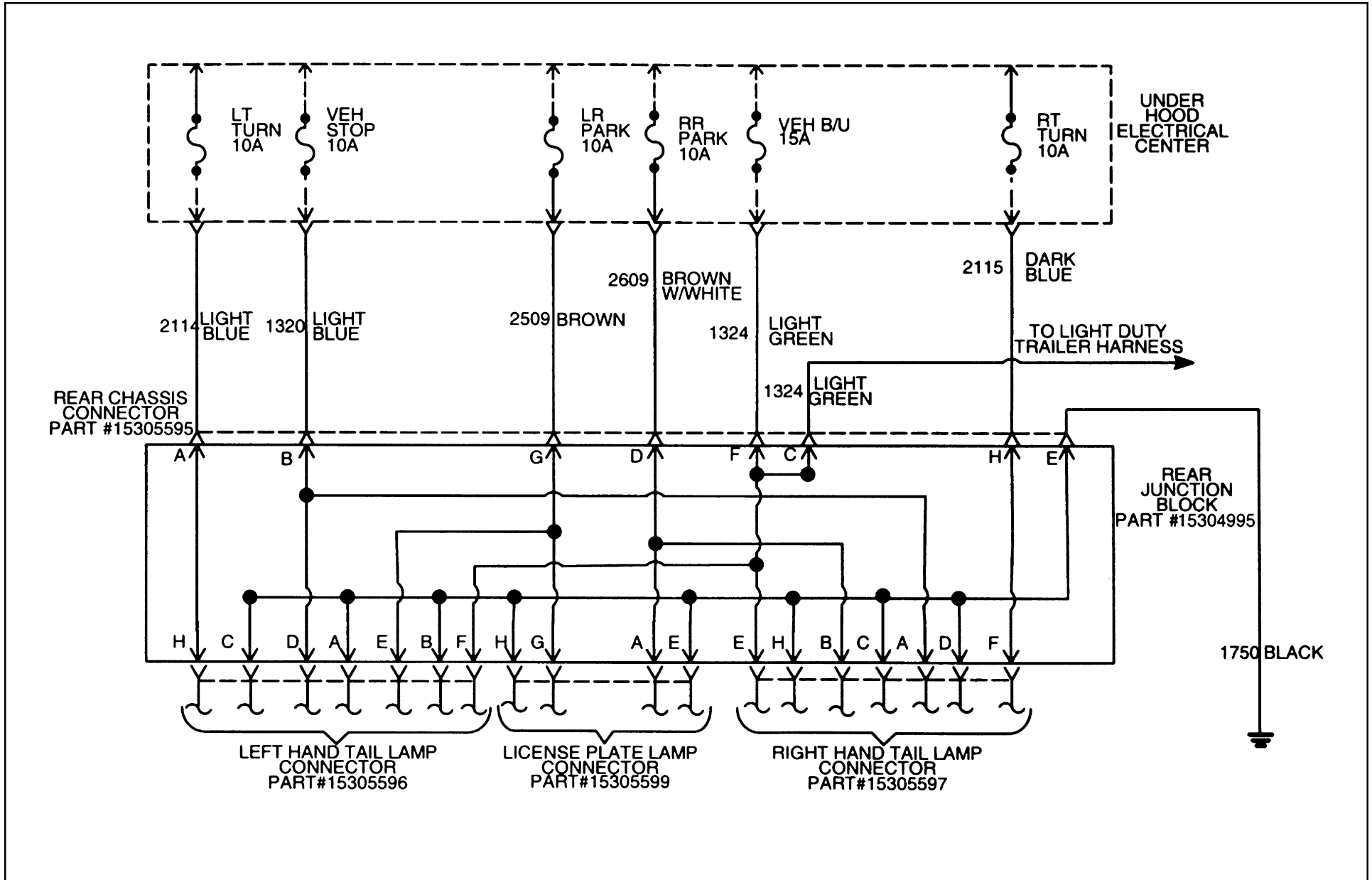

Rear Junction Block and Bracket Installation – Chassis Cab (ZW9) Trucks

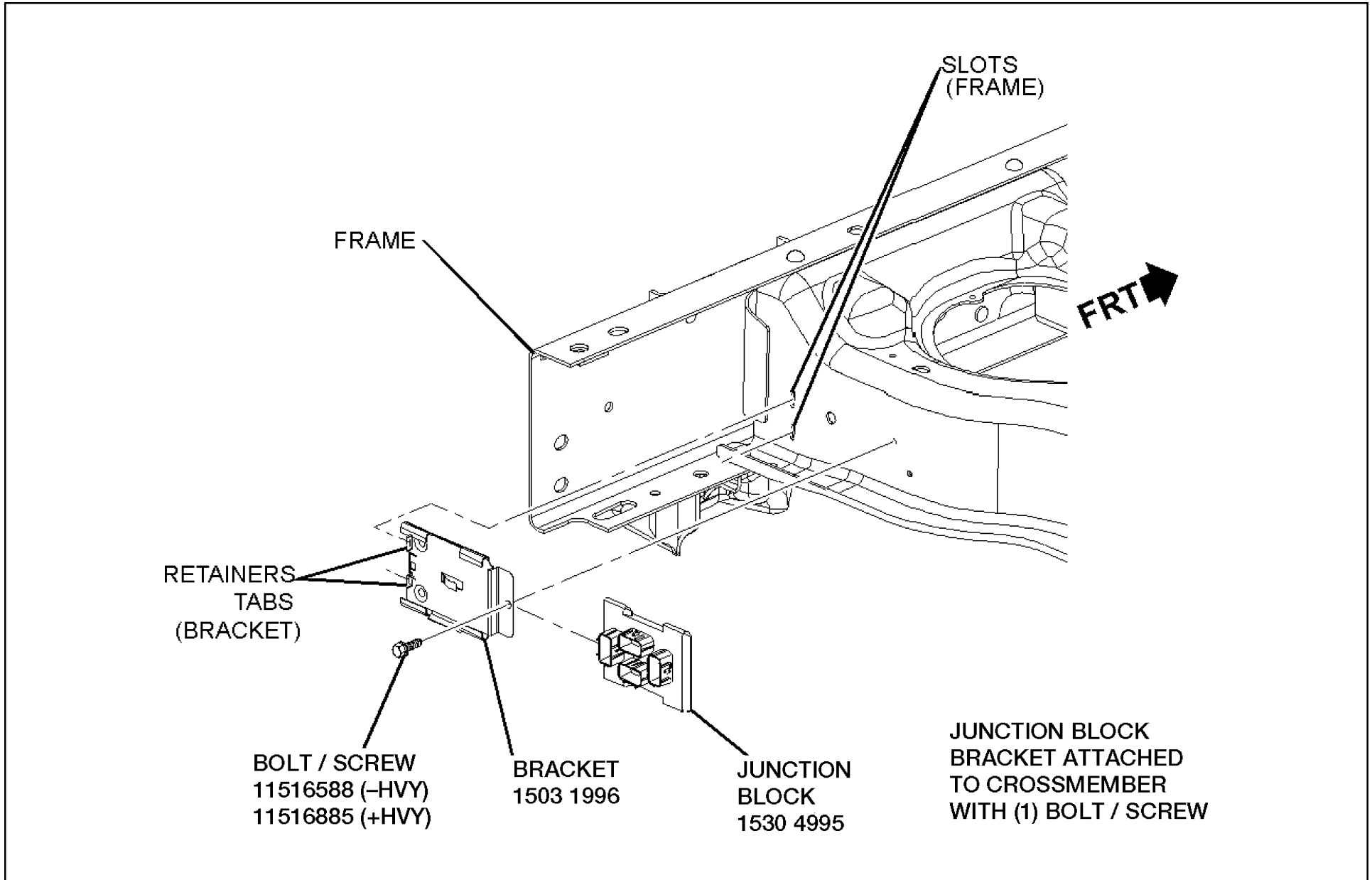

Left Hand Tail Lamp to Frame – Chassis Cab (ZW9) Trucks

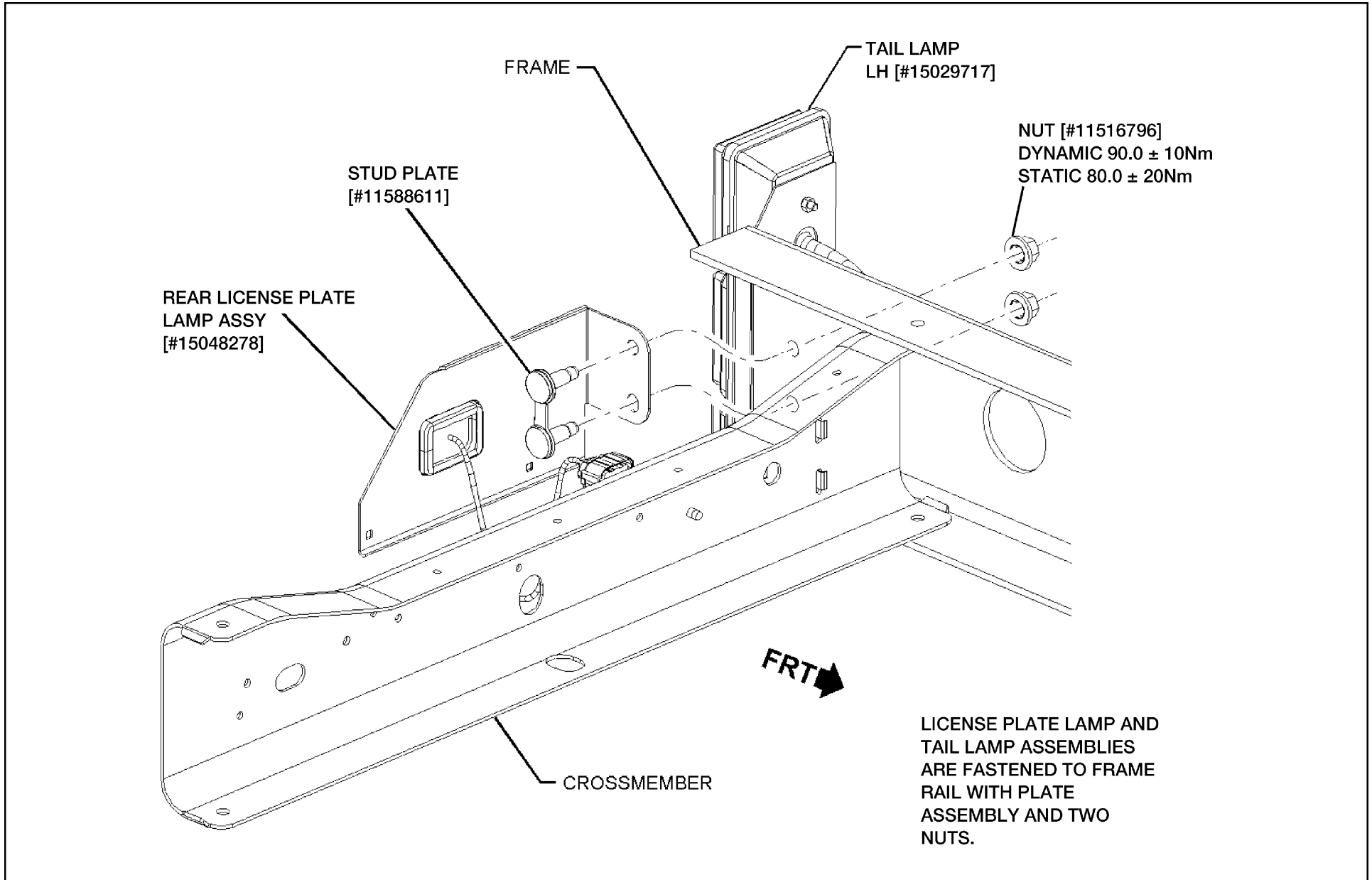

Left Hand Tail Lamp and License Plate Lamp to Junction Block – Chassis Cab (ZW9) Trucks

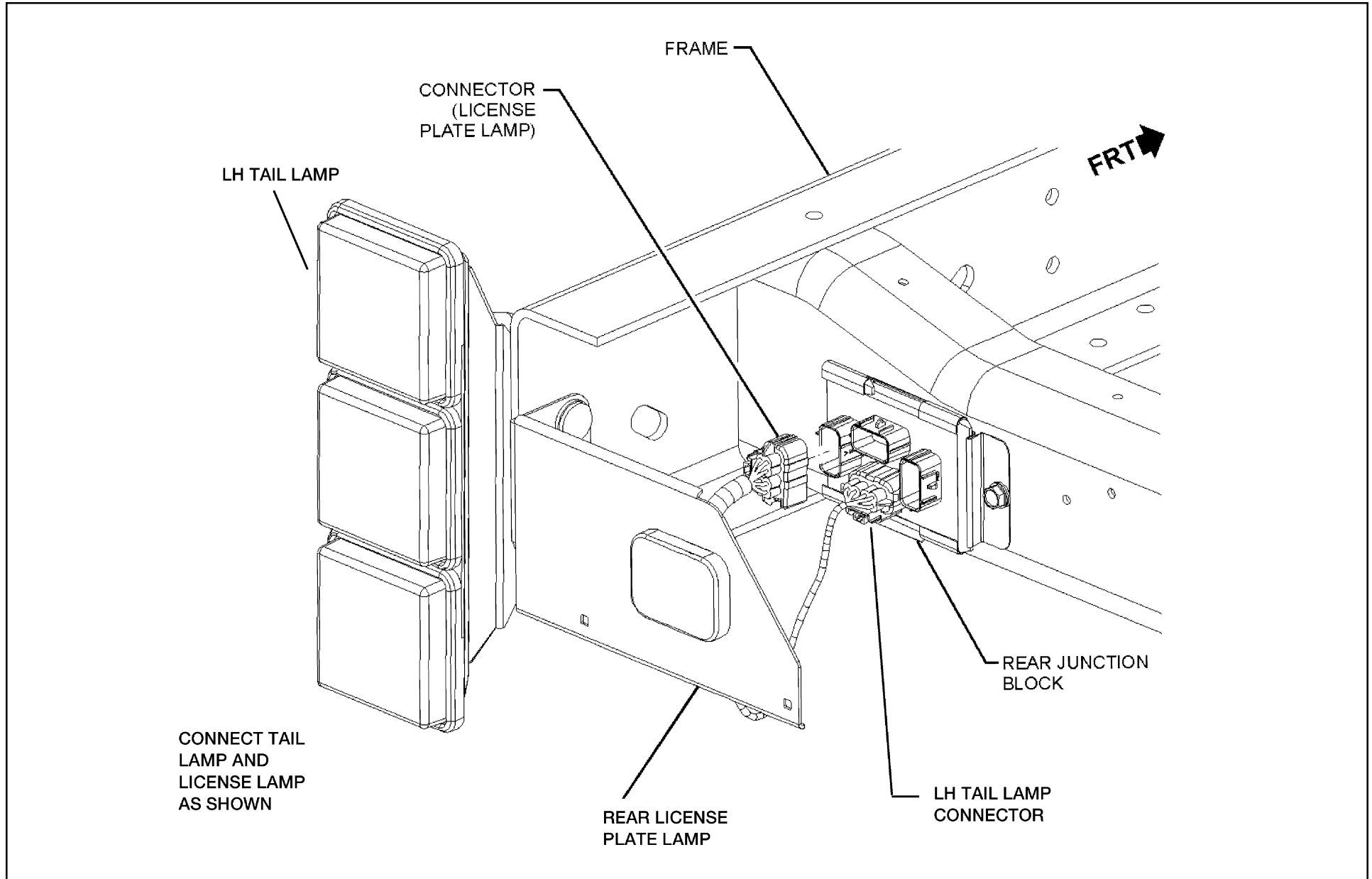

Right Hand Tail Lamp to Frame - Chassis Cab (ZW9) Trucks

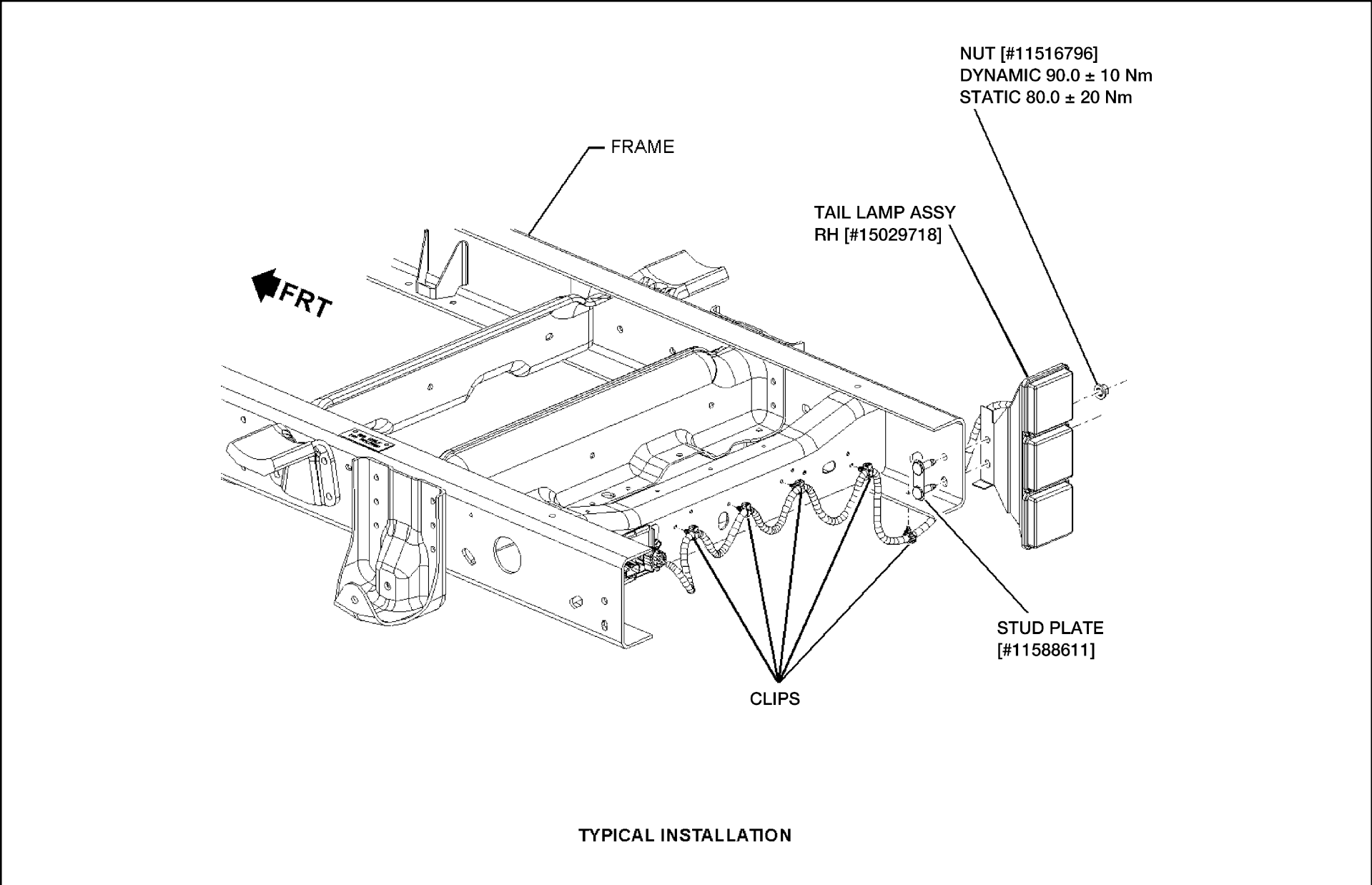

Right Tail Lamp Harness to Junction Block – Chassis Cab (ZW9) Trucks

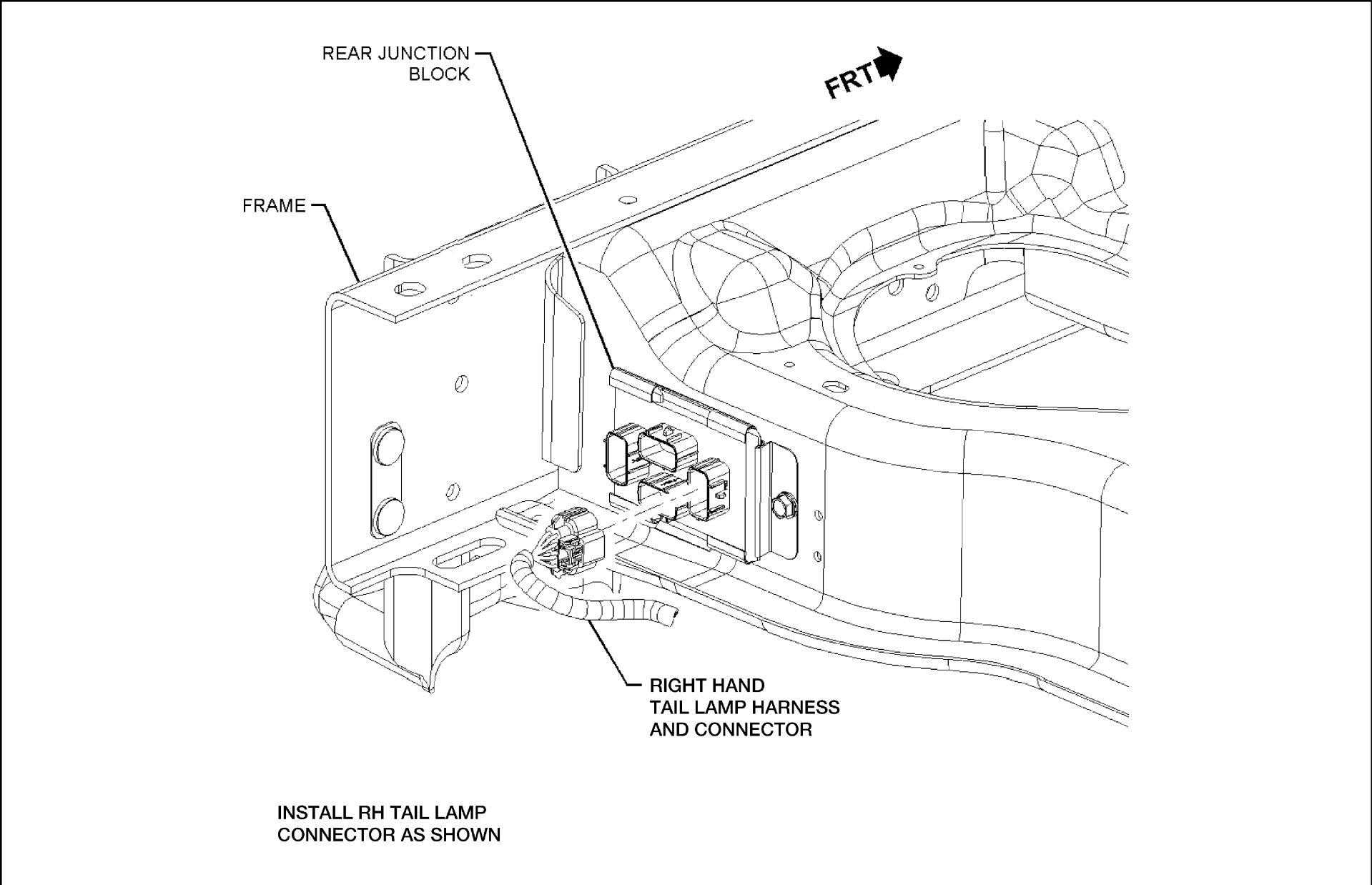

Basic Trailer Wiring Package

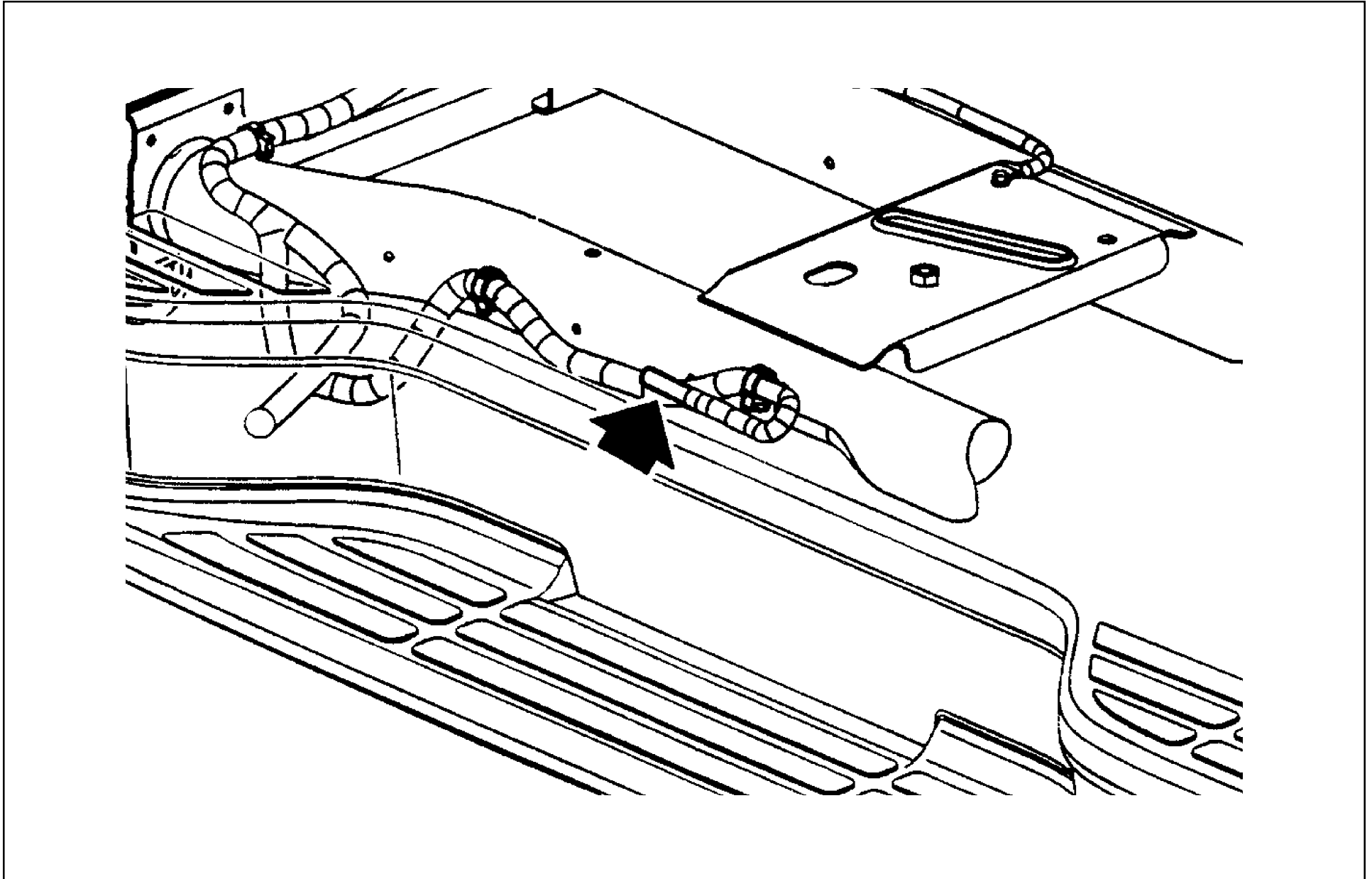

Heavy Duty Trailer Wiring Package (If Equipped)

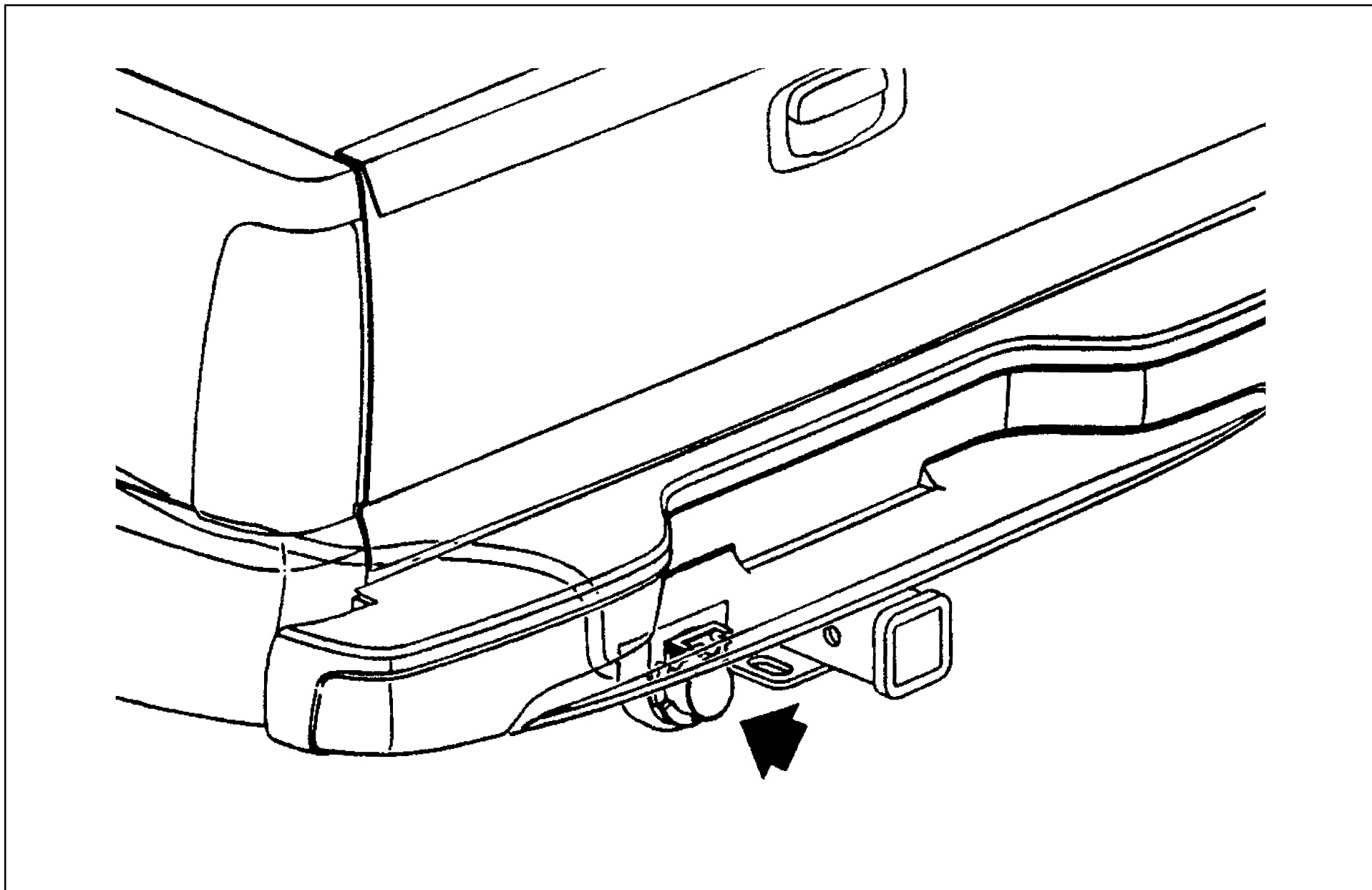

Trailer Wiring Stop/Turn Circuit Electrical Diagram

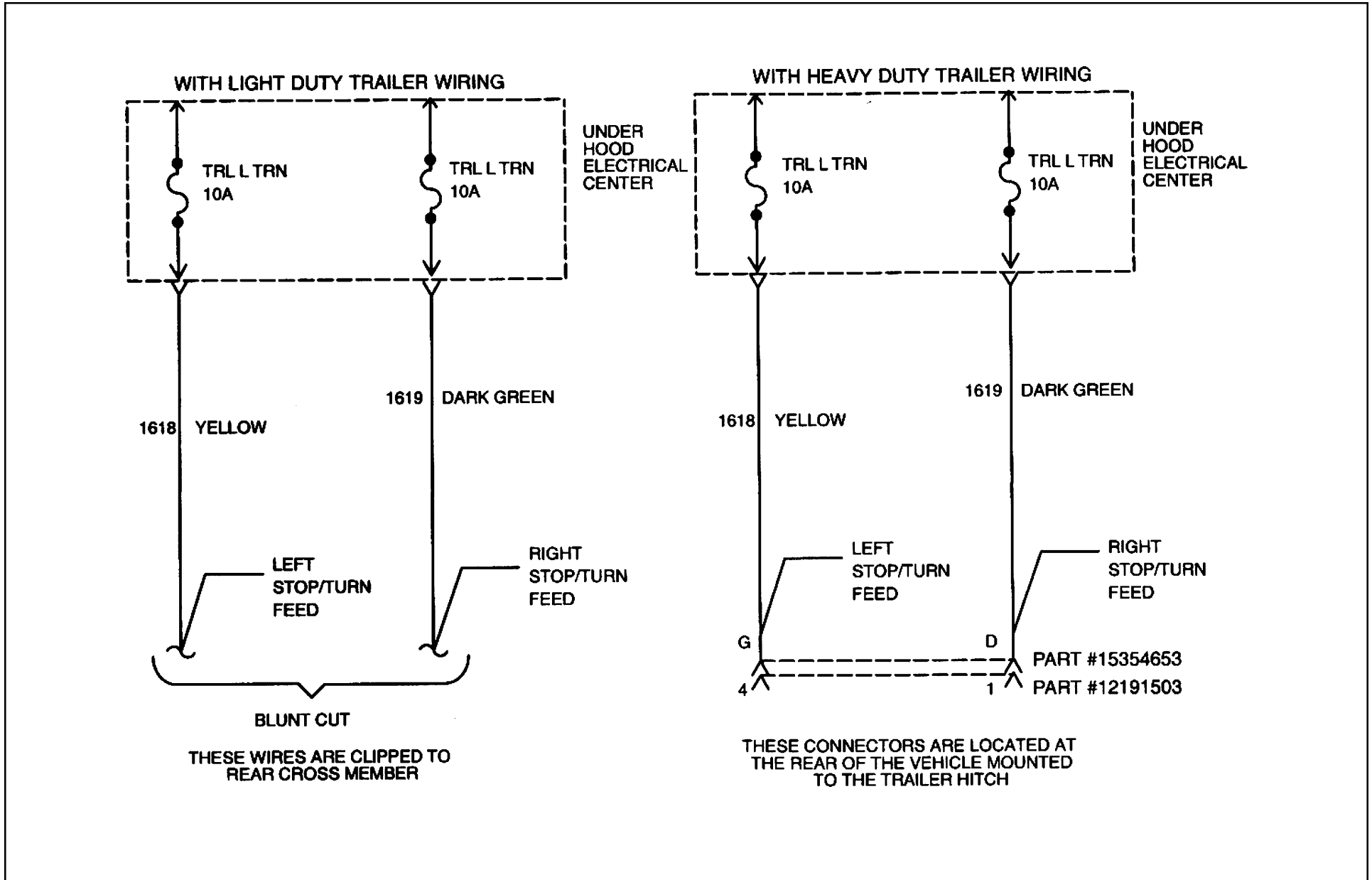

Rear Junction Block – Rear Chassis Harness Connector

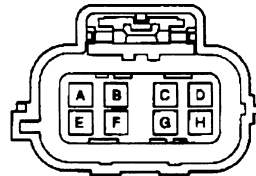

<u>CAVITY</u>	<u>WIRE COLOR</u>	<u>CIRCUIT NO.</u>	<u>FUNCTION</u>
A	LIGHT BLUE	2114	LEFT TURN SIGNAL
B	LIGHT BLUE	1320	STOP LAMPS (CHMSL)
C	LIGHT GREEN	24	VEHICLE BACKUP LAMPS
D	BROWN W/WHITE	2609	RIGHT REAR PARKING LAMPS
E	BLACK	1750	GROUND
F	---	---	NOT USED
G	BROWN	2509	LEFT REAR PARKING LAMPS
H	DARK BLUE	2115	RIGHT TURN SIGNAL

Connector Information

8-way Connector Assy. Part No.:15317304 Color: Blue

Mating Connector Information

In addition to the Rear Junction Block, the rear junction block connector can be mated with the following in-line connector:

Connector Part No.: 15326788

Primary Lock Reinforcement (PLR): 15326794

Total Position Assurance (TPA) clip: 15317301

Rear Junction Block - Left Hand Tail Lamp Connector

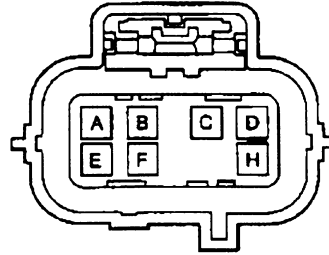

CAVITY	WIRE COLOR	CIRCUIT NO.	FUNCTION
A	BLACK	1750	GROUND - LH STOP/PARK LAMPS
B	BLACK	1750	GROUND - LH BACKUP LAMP
C	BLACK	1750	GROUND-LH TURN SIGNAL LAMP
D	LIGHT BLUE	1320	LEFT STOP LAMP
E	BROWN	2509	LEFT REAR PARKING LAMP
F	LIGHT GREEN	24	LEFT BACKUP LAMP
G	---	---	NOT USED
H	LIGHT BLUE	2114	LEFT TURN SIGNAL LAMP

Connector Information

8-way Connector Assy. Part No.:15317305

Color: Gray

Primary Lock reinforcement (PLR): 15326794

Total Position Assurance (TPA) clip: 15317301

Rear Junction Block – Right Hand Tail Lamp Connector

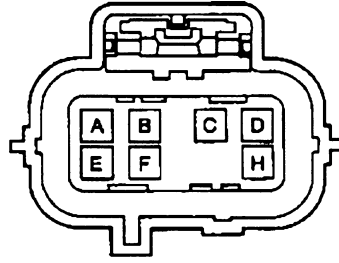

CAVITY	WIRE COLOR	CIRCUIT NO.	FUNCTION
A	LIGHT BLUE	1320	RIGHT STOP LAMP
B	BROWN W/WHITE	2609	RIGHT REAR PARKING LAMP
C	BLACK	1750	GROUND - RH STOP/ PARK LAMP
D	BLACK	1750	GROUND - RH TURN SIGNAL LAMP
E	LIGHT GREEN	24	RIGHT BACKUP LAMP
F	DARK BLUE	2115	RIGHT TURN SIGNAL LAMP
G	---	---	NOT USED
H	BLACK	1750	GROUND - RH BACKUP LAMP

Connector Information

Connector Assy. Part No.: 15317306

Color: Black

Primary Lock Reinforcement (PLR): 15326794

Total Position Assurance (TPA) clip: 15317301

Rear Junction Block – License Plate Lamp Connector

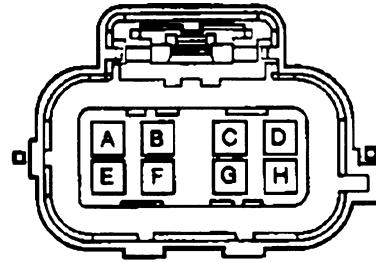

CAVITY	WIRE COLOR	CIRCUIT NO.	FUNCTION
A	BROWN W/WHITE	2609	RIGHT LICENSE PLATE LAMP
B	---	---	NOT USED
C	BLACK	1750	GROUND - LEFT LICENSE PLATE LAMP
D	BLACK	1750	GROUND - RIGHT TURN
E	BLACK	1750	GROUND-RIGHT LICENSE PLATE LAMP
F	---	---	NOT USED
G	BROWN	2509	LEFT LICENSE PLATE LAMP
H	---	---	NOT USED

Connector Information

Connector Assy. Part No.: 15317308

Color: White

Primary Lock Reinforcement (PLR): 15326794

Total Position Assurance (TPA) clip: 15317301

Rear Bumper Removal Wiring Modifications

Trucks ordered with the Rear Bumper Delete (VF7) option will come equipped with the Rear License Plate Lamp Assembly which is fastened to the left frame rail as shown on page 90. The License Plate Connector is mated with the Rear Junction Block as shown on page 91.

The parts required to attach the Rear License Plate Lamp Assembly to the left frame rail are as follows:

- Rear License Plate Lamp Assembly Part Number:15048278
- Stud/plate Assembly (one required) Part Number:11588611
- Nut (two required) Part Number:11516796

License Plate Lamp to Rear Junction Block – Pickup with Rear Bumper Delete (VF7)

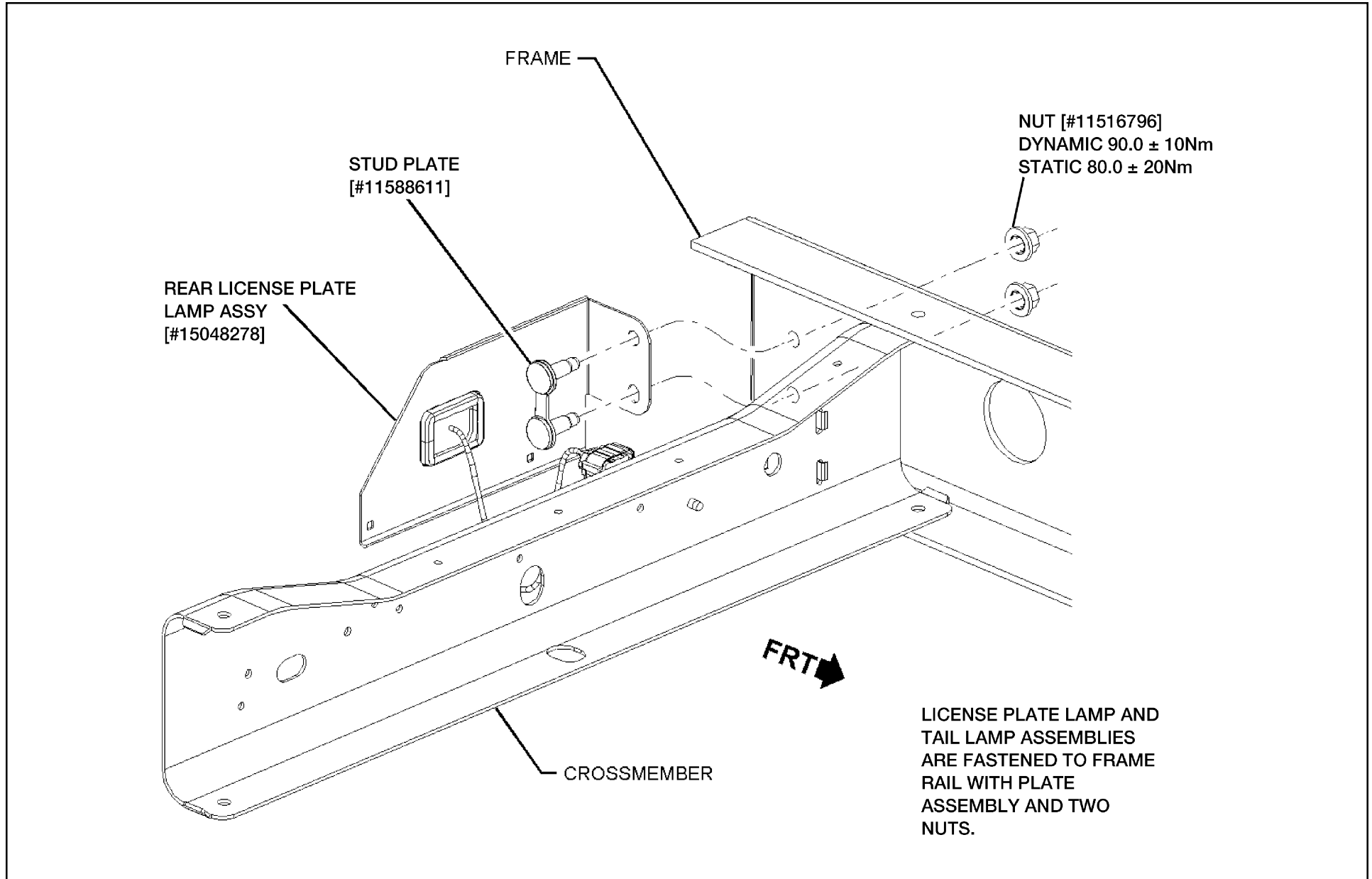

TRAILERING INFORMATION

How to Use GCWRs to Determine Powertrain and Rear Axle Ratio for Trailering

Use Gross Combination Weight Ratings (GCWRs) to determine the engine, transmission, and rear axle ratio you will require to tow a trailer with your vehicle. The chart below shows you the maximum allowable GCWR based on all the available engines and rear axle ratios with automatic or manual transmissions.

The GCWR includes the total loaded weight of both the vehicle and trailer. Any available engine may be used for trailering if the GCWR shown is not exceeded. The trailer weight can be increased by 25% if the vehicle speed will not exceed 25 mph.

2004 Gross Combination Weight Ratings (GCWR)

S/T Utility (GMT305) Models (GMC Envoy XUV)

GCWR (lbs.)	5,000	5,500	6,500	7,500	8,000	8,500	9,000	9,500	10,000	10,500	11,000	11,500	12,000	12,500	13,000	14,000	15,000	16,000	17,000	19,000	20,000	22,000
Engine	Rear Axle Ratio with Automatic Transmission																					
4.2L L6 Gas									3.42	3.73	4.10											
5.3L V8 Gas											3.42			3.73								

S/T Pickup (GMT 355) Models (Chevy Colorado and GMC Canyon)

GCWR (lbs.)	5,000	5,500	6,000	7,000	7,500	8,500	9,000	9,500	10,000	10,500	11,000	11,500	12,000	12,500	13,000	14,000	15,000	16,000	17,000	19,000	20,000	22,000
Engine	Rear Axle Ratio with Automatic Transmission																					
2.8L L4 Gas				3.73/ 4.10																		
3.5L L5 Gas						3.42	3.73 ⁽¹⁾ /4.10															
Engine	Rear Axle Ratio with Manual Transmission																					
2.8L L4 Gas		3.42	3.73/ 4.10																			
3.5L L5 Gas				3.42	3.73/ 4.10																	

NOTES: (1) GCWR limited to 8,500 lbs. on S15403

(GCWR Ratings – continued on next page)

SPECIAL APPLICATIONS

(GCWR Ratings – continued from previous page)

S/T Pickups and Utilities (GMT 325/330) Models (Chevy S10/Blazer and GMC Sonoma/Jimmy)

GCWR (lbs.)	5,000	5,500	6,500	7,500	8,000	8,500	9,000	9,500	10,000	10,500	11,000	11,500	12,000	12,500	13,000	14,000	15,000	16,000	17,000	19,000	20,000	22,000	
Engine	Rear Axle Ratio with Automatic Transmission																						
4.3L V6 Gas								3.42 ⁽¹⁾															
								3.73 ⁽²⁾															
Engine	Rear Axle Ratio with Manual Transmission																						
4.3L V6 Gas					3.42 ⁽¹⁾	3.73																	

NOTES: (1) GCWR limited to 6,500 lbs. with V4A Xtreme Blazer
 (2) GCWR limited to 9,000 lbs. with ZR2 Suspension

S Pickup (GMT368) Model (Chevy SSR)

GCWR (lbs.)	5,000	5,500	6,500	7,500	8,000	8,500	9,000	9,500	10,000	10,500	11,000	11,500	12,000	12,500	13,000	14,000	15,000	16,000	17,000	19,000	20,000	22,000	
Engine	Rear Axle Ratio with Automatic or Manual Transmission ¹																						
5.3L V8 Gas					3.73																		

S/T Utility (GMT360) Models (Chevy TrailBlazer and GMC Envoy)

GCWR (lbs.)	5,000	5,500	6,500	7,500	8,000	8,500	9,000	9,500	10,000	10,500	11,000	11,500	12,000	12,500	13,000	14,000	15,000	16,000	17,000	19,000	20,000	22,000	
Engine	Rear Axle Ratio with Automatic or Manual Transmission ⁽¹⁾																						
4.2L L6 Gas									3.42	3.73 ⁽²⁾	4.10												
5.3L V8 Gas												3.73											

NOTES: (1) Manual transmission only available on export models
 (2) GCWR raised to 11,000 lbs. for European export

S/T Utility (GMT370) Models (Chevy TrailBlazer EXT and GMC Envoy XL)

GCWR (lbs.)	5,000	5,500	6,500	7,500	8,000	8,500	9,000	9,500	10,000	10,500	11,000	11,500	12,000	12,500	13,000	14,000	15,000	16,000	17,000	19,000	20,000	22,000	
Engine	Rear Axle Ratio with Automatic Transmission																						
4.2L L6 Gas									3.42	3.73	4.10												
5.3L V8 Gas											3.42			3.73									

(GCWR Ratings – continued on next page)

SPECIAL APPLICATIONS

(GCWR Ratings – continued from previous page)

C/K 15/25/25HD/35/36 Series Pickup and Cab-Chassis Models⁽¹⁾ (Chevy Silverado and GMC Sierra)

GCWR (lbs.)	5,000	5,500	6,500	7,500	8,000	8,500	9,000	9,500	10,000	10,500	11,000	11,500	12,000	12,500	13,000	14,000	15,000	16,000	17,000	19,000	20,000	22,000	
Engine	Rear Axle Ratio with Automatic Transmission																						
4.3L V6 Gas							3.08	3.42	3.73														
4.8L V8 Gas											3.42		3.73		4.10								
5.3L V8 Gas													3.42		3.73	4.10							
6.0L V8 Alt Fuel															3.73	4.10							
6.0L V8 Gas																3.73		4.10 ⁽²⁾					
8.1L V8 Gas																						3.73	4.10
6.6L V8 Turbo Diesel																							3.73
Engine	Rear Axle Ratio with Manual Transmission																						
4.3L V6 Gas					3.08	3.42	3.73																
4.8L V8 Gas							3.42		3.73		4.10												
6.0L V8 Gas																3.73		4.10					
8.1L V8 Gas																							4.10
6.6L V8 Turbo Diesel																							3.73

NOTES: (1) 36 Series models are incomplete vehicles and trailer ratings are not assigned; use GCWR chart to determine combination weight limit

(2) 13,000 lbs. for Silverado SS.

C/K Utility Models (Chevy Tahoe/Suburban and GMC Yukon/Yukon XL)

GCWR (lbs.)	5,000	5,500	6,500	7,500	8,000	8,500	9,000	9,500	10,000	10,500	11,000	11,500	12,000	12,500	13,000	14,000	15,000	16,000	17,000	19,000	20,000	22,000	
Engine	Rear Axle Ratio with Automatic Transmission																						
4.8L V8 Gas											3.42		3.73		4.10								
5.3L V8 Gas													3.42		3.73	4.10							
6.0L V8 Gas																3.73		4.10 ⁽¹⁾					
8.1L V8 Gas																			3.73	4.10			

NOTES: (1) GCWR limited to 14,000 lbs. with CK25906 with Z83 Suspension

(GCWR Ratings – continued on next page)

SPECIAL APPLICATIONS

(GCWR Ratings – continued from previous page)

C/K Luxury Utility Models (Cadillac Escalade and GMC Denali)

GCWR (lbs.)	5,000	5,500	6,500	7,500	8,000	8,500	9,000	9,500	10,000	10,500	11,000	11,500	12,000	12,500	13,000	14,000	15,000	16,000	17,000	19,000	20,000	22,000	
Engine	Rear Axle Ratio with Automatic Transmission																						
5.3L V8 Gas															3.73								
6.0L V8 Gas																3.73							

C/K Ultimate Utility Models (Cadillac Escalade EXT and Chevy Avalanche)

GCWR (lbs.)	5,000	5,500	6,500	7,500	8,000	8,500	9,000	9,500	10,000	10,500	11,000	11,500	12,000	12,500	13,000	14,000	15,000	16,000	17,000	19,000	20,000	22,000	
Engine	Rear Axle Ratio with Automatic Transmission																						
5.3L V8 Gas															3.73	4.10							
6.0L V8 Gas																3.73							
8.1L V8 Gas																			3.73	4.10			

H2 Utility Models (Hummer)

GCWR (lbs.)	5,000	5,500	6,500	7,500	8,000	8,500	9,000	9,500	10,000	10,500	11,000	11,500	12,000	13,000	13,500	14,000	15,000	16,000	17,000	19,000	20,000	22,000	
Engine	Rear Axle Ratio with Automatic Transmission																						
6.0L V8 Gas															4.10								

M/L Van Models (Chevy Astro and GMC Safari)

GCWR (lbs.)	5,000	5,500	6,500	7,500	8,000	8,500	9,000	9,500	10,000	10,500	11,000	11,500	12,000	12,500	13,000	14,000	15,000	16,000	17,000	19,000	20,000	22,000	
Engine	Rear Axle Ratio with Automatic Transmission																						
4.3L V6 Gas								3.42	3.73														

(GCWR Ratings – continued on next page)

SPECIAL APPLICATIONS

(GCWR Ratings – continued from previous page)

G/H Van (GMT610) Models⁽¹⁾ (Chevy Express and GMC Savana)

GCWR (lbs.)	5,000	5,500	6,500	7,500	8,000	8,500	9,000	9,500	10,000	10,500	11,000	11,500	12,000	12,500	13,000	14,000	15,000	16,000	17,000	19,000	20,000	22,000	
Engine	Rear Axle Ratio with Automatic Transmission																						
4.3L V6 Gas								3.42	3.73														
4.8L V8 Gas													3.73		4.10								
5.3L V8 Gas													3.42/ 3.73										
6.0L V8 Alt Fuel															3.73								
6.0L V8 Gas																3.73		4.10					

NOTES: (1) 03 Cutaway models are incomplete vehicles and trailer ratings are not assigned; use GCWR chart to determine combination weight limit

2004 Maximum Trailer Ratings

Weight Carrying Hitch and Weight Carrying Distribution Hitch and Sway Control

S/T (GMT325) Pickup Models (Chevy S10 and GMC Sonoma)

Weight carrying hitch limit: 3,500-lb. trailer with 350-lb. tongue weight.
Weight distributing hitch and sway control required over 3,500-lb. trailer weight.

MODEL	AUTOMATIC TRANSMISSION RATINGS 4.3L V6 GAS	
	AXLE RATIO	MAX. TRAILER WEIGHT
T10643	3.42	5200
	3.73	5200

NOTES: Trailer ratings are calculated assuming a standard equipped vehicle plus driver. Optional equipment, passengers or cargo will reduce trailering capacity. Trailer tongue weight should be 10 to 15% of total loaded trailer weight up to 750 lbs. Trailering capacity may be limited by tow vehicle ability to carry tongue weight. Addition of trailer tongue weight cannot cause vehicle weights to exceed Rear Gross Axle Weight Rating (RGAWR) or Gross Vehicle Weight Rating (GVWR). Base cooling system includes all content required to attain maximum trailer rating.

SPECIAL APPLICATIONS

S/T (GMT330) Utility Models (Chevy Blazer)

Weight carrying hitch limit: 3,500-lb. trailer with 350-lb. tongue weight.
 Weight distributing hitch and sway control required over 3,500-lb. trailer weight.

MODEL	AUTOMATIC TRANSMISSION RATINGS 4.3L V6 GAS		MANUAL TRANSMISSION RATINGS 4.3L V6 GAS	
	AXLE RATIO	MAX. TRAILER WEIGHT	AXLE RATIO	MAX. TRAILER WEIGHT
S10516	3.42	5700	3.42	4200
S10516 & ZR2	3.73	4900		
S10516 & V4A	3.42	2000	3.42	2000
S10506	3.42	5500		
T10516	3.42 3.73	5400 5400	3.42	3900
T10516 & ZR2	3.73	4700	3.73	4200
T10506	3.42 3.73	5200 5200		

NOTES: Trailer ratings are calculated assuming a standard equipped vehicle plus driver. Optional equipment, passengers or cargo will reduce trailering capacity. Trailer tongue weight should be 10 to 15% of total loaded trailer weight up to 750 lbs. Addition of trailer tongue weight cannot cause vehicle weights to exceed Rear Gross Axle Weight Rating (RGAWR) or Gross Vehicle Weight Rating (GVWR). Base cooling system includes all content required to attain maximum trailer rating. Z82 Heavy Duty Trailering Equipment Package includes weight distributing hitch platform and trailer wiring harness.

SPECIAL APPLICATIONS

S/T (GMT355) Pickup Models (Chevy Colorado and GMC Canyon)

Weight carrying hitch limit: 4,000-lb. trailer with 500-lb. tongue weight.
Weight distributing hitch and sway control not required.

MODEL	MANUAL TRANS. RATINGS 2.8L L4 GAS		MANUAL TRANS. RATINGS 3.5L L5 GAS		AUTOMATIC TRANS. RATINGS 2.8L L4 GAS		AUTOMATIC TRANS. RATINGS 3.5L L5 GAS			
	AXLE RATIO	MAX. TRAILER WEIGHT	AXLE RATIO	MAX. TRAILER WEIGHT	AXLE RATIO	MAX. TRAILER WEIGHT	AXLE RATIO	MAX. TRAILER WEIGHT		
S15403	3.42	2000	3.42	3500	3.73	3500	3.42	4000		
	3.73	2500	3.73	3900			3.73	4000		
S15653	3.42	1700	3.42	3200	3.73	3200	3.42	4000		
	3.73	2200	3.73	3600			3.73	4000		
S15643	3.42	1600			3.73	3100	3.42	4000		
	3.73	2100					3.73	4000		
T15403	3.73	2100	3.42	3100	3.73	3100	3.42	4000		
	4.10	2100	3.73	3600			4.10	3100	3.73	4000
			4.10	3500			4.10	4000		
T15653	4.10	1900	3.42	2900	3.73	2900	3.42	4000		
			3.73	3400			4.10	2900	3.73	4000
			4.10	3300			4.10	4000		
T15643	4.10	1800			3.73	2800	3.42	4000		
							4.10	2800	3.73	4000
							4.10	4000		

NOTES: Trailer ratings are calculated assuming a standard equipped vehicle plus driver. Optional equipment, passengers or cargo will reduce trailering capacity. Weight distributing hitch not required or recommended. Trailer tongue weight should be 10 to 15% of total loaded trailer weight up to 500 lbs. Addition of trailer tongue weight cannot cause vehicle weights to exceed Rear Gross Axle Weight Rating (RGAWR) or Gross Vehicle Weight Rating (GVWR). Base cooling system includes all content required to attain maximum trailer rating. No optional cooling equipment available. Trailer hitch platform and four-wire trailer wiring harness are available as dealer-installed accessories.

SPECIAL APPLICATIONS

S/T (GMT305) XUV Models (GMC Envoy XUV)

Weight carrying hitch limit: 4,000-lb. trailer with 400-lb. tongue weight.
 Weight distributing hitch and sway control required over 4,000-lb. trailer weight.

MODEL	AUTOMATIC TRANSMISSION RATINGS 4.2L L6 GAS		AUTOMATIC TRANSMISSION RATINGS 5.3L V8 GAS	
	AXLE RATIO	MAX. TRAILER WEIGHT	AXLE RATIO	MAX. TRAILER WEIGHT
S15836	3.42	4800	3.42	5800
	3.73	5300	3.73	6500
	4.10	5800		
T15836	3.42	4700	3.42	5600
	3.73	5200	3.73	6400
	4.10	5700		

NOTES: Trailer ratings are calculated assuming a standard equipped vehicle plus driver. Optional equipment, passengers or cargo will reduce trailering capacity. Trailer tongue weight should be 10 to 15% of total loaded trailer weight up to 900 lbs. Trailering capacity may be limited by tow vehicle ability to carry trailer tongue weight. Addition of trailer tongue weight cannot cause vehicle weights to exceed Rear Gross Axle Weight Rating (RGAWR) or Gross Vehicle Weight Rating (GVWR). Base cooling system includes all content required to attain maximum trailer rating.

SPECIAL APPLICATIONS

S/T (GMT360) Utility Models (Chevy TrailBlazer and GMC Envoy)

Weight carrying hitch limit: 4,000-lb. trailer with 400-lb. tongue weight.
 Weight distributing hitch and sway control required over 4,000-lb. trailer weight.

MODEL	AUTOMATIC TRANSMISSION RATINGS 4.2L L6 GAS		AUTOMATIC TRANSMISSION RATINGS 5.3L V8 GAS	
	AXLE RATIO	MAX. TRAILER WEIGHT	AXLE RATIO	MAX. TRAILER WEIGHT
S15506 ⁽¹⁾	3.42	5300		
	3.73	5800		
	4.10	6300		
T15506 ⁽¹⁾	3.42	5100		
	3.73	5600		
	4.10	6100		
S15506 &W49	3.73	5700	3.73	6700
	4.10	6200		
T15506 &W49	3.73	5500	3.73	6500
	4.10	6100		

NOTES: Trailer ratings are calculated assuming a standard equipped vehicle plus driver. Optional equipment, passengers or cargo will reduce trailering capacity. Trailer tongue weight should be 10 to 15% of total loaded trailer weight up to 750 lbs. Trailering capacity may be limited by tow vehicle ability to carry trailer tongue weight. Addition of trailer tongue weight cannot cause vehicle weights to exceed Rear Gross Axle Weight Rating (RGAWR) or Gross Vehicle Weight Rating (GVWR). Base cooling system includes all content required to attain maximum trailer rating. 3.42 axle ratio N/A on Z70, Z89 or W49 models; 4.10 axle ratio N/A on Z89 models. Export ratings (automatic or manual transmission) same as North American ratings except for Europe, where rating with 3.73 axle equals GVWR. Weight distribution and sway control not required for European trailering; typical trailer tongue weight percentage is 4%.

(1) Chevy X88, GMC Z88, Buick W49, Olds Z70 and Isuzu Z89.

SPECIAL APPLICATIONS

S/T (GMT370) Utility Models (Chevy TrailBlazer EXT and GMC Envoy XL)

Weight carrying hitch limit: 4,000-lb. trailer with 400-lb. tongue weight.
 Weight distributing hitch and sway control required over 4,000-lb. trailer weight.

MODEL	AUTOMATIC TRANSMISSION RATINGS 4.2L L6 GAS		AUTOMATIC TRANSMISSION RATINGS 5.3L V8 GAS	
	AXLE RATIO	MAX. TRAILER WEIGHT	AXLE RATIO	MAX. TRAILER WEIGHT
S15806 & X88/Z88	3.42	5000	3.42	5900
	3.73	5500	3.73	7100
	4.10	6000		
S15806 & Z89	3.73	5500	3.73	6800
T15806 & X88/Z88	3.42	4800	3.42	5700
	3.73	5300	3.73	6700
	4.10	5800		
T15806 & Z89	3.73	5300	3.73	6300

NOTES: Trailer ratings are calculated assuming a standard equipped vehicle plus driver. Optional equipment, passengers or cargo will reduce trailering capacity. Trailer tongue weight should be 10 to 15% of total loaded trailer weight up to 900 lbs. Trailering capacity may be limited by tow vehicle ability to carry trailer tongue weight. Addition of trailer tongue weight cannot cause vehicle weights to exceed Rear Gross Axle Weight Rating (RGAWR) or Gross Vehicle Weight Rating (GVWR). Base cooling system includes all content required to attain maximum trailer rating.

SPECIAL APPLICATIONS

S/T (GMT368) Pickup Models (Chevy SSR)

Weight carrying hitch limit: 2,500-lb. trailer with 250-lb. tongue weight.
Weight distributing hitch and sway control required.

MODEL	AUTOMATIC TRANSMISSION RATINGS 5.3L V8 GAS	
	AXLE RATIO	MAX. TRAILER WEIGHT
S15703	3.73	2500

NOTES: Trailer ratings are calculated assuming a standard equipped vehicle plus driver. Optional equipment, passengers or cargo will reduce trailering capacity. Trailer tongue weight should be 10 to 15% of total loaded trailer weight up to 250 lbs. Trailering capacity may be limited by tow vehicle ability to carry trailer tongue weight. Addition of trailer tongue weight cannot cause vehicle weights to exceed Rear Gross Axle Weight Rating (RGAWR) or Gross Vehicle Weight Rating (GVWR). Base cooling system includes all content required to attain maximum trailer rating.

SPECIAL APPLICATIONS

C/K 15/25 Series Light Duty Pickup Models (Manual Transmission) (Chevy Silverado and GMC Sierra)

Weight carrying hitch limit: 5,000-lb. trailer with 600-lb. tongue weight.

Weight distributing hitch and sway control required over 5,000-lb. trailer weight.

MODEL	MANUAL TRANSMISSION RATINGS 4.3L V6 GAS		MANUAL TRANSMISSION RATINGS 4.8L V8 GAS		MANUAL TRANSMISSION RATINGS 6.0L V8 GAS	
	AXLE RATIO	MAX. TRAILER WEIGHT	AXLE RATIO	MAX. TRAILER WEIGHT	AXLE RATIO	MAX. TRAILER WEIGHT
C15703	3.08 3.42	3600 4100	3.42 3.73	4500 5400		
C15903	3.08 3.42	3400 3900	3.42 3.73	4300 5300		
C15753	3.42	3700	3.42 3.73	4100 5100		
C15953			3.42 3.73	3900 4900		
C25903 & C6P					3.73 4.10	8800 10800
K15703	3.42 3.73	3800 4300	3.73 4.10	5200 6200		
K15903	3.42 3.73	3600 4100	3.73 4.10	5000 6000		
K15753			3.73 4.10	4800 5800		
K15953			3.73 4.10	4700 5700		
K25753 & C6P					3.73 4.10	8300 10300

NOTES: Trailer ratings are calculated assuming a standard equipped vehicle plus driver. Optional equipment, passengers or cargo will reduce trailering capacity. C/K15 models are limited to 5,000-lb. trailer rating unless equipped with Z85 Increased Capacity or ZX3 Manual Select Damping or Z71 Off-Road Suspension Package. Trailer tongue weight should be 10 to 15% of total loaded trailer weight up to 1,000 lbs. on C/K15 models and up to 1,500 lbs. on C/K25 models. Trailering capacity may be limited by tow vehicle ability to carry trailer tongue weight. Addition of trailer tongue weight cannot cause vehicle weights to exceed Rear Gross Axle Weight Rating (RGAWR) or Gross Vehicle Weight Rating (GVWR). Base cooling system includes all content required to attain maximum trailer rating. Z82 Heavy Duty Trailering Equipment Package includes trailer hitch platform, trailer electrical connector and suspension upgrade if necessary.

SPECIAL APPLICATIONS

C 15/25 Series Light Duty Pickup Models (Automatic Transmission) (Chevy Silverado and GMC Sierra)

Weight carrying hitch limit: 5,000-lb. trailer with 600-lb. tongue weight.
 Weight distributing hitch and sway control required over 5,000-lb. trailer weight.

MODEL	AUTOMATIC TRANS. RATINGS 4.3L V6 GAS		AUTOMATIC TRANS. RATINGS 4.8L V8 GAS		AUTOMATIC TRANS. RATINGS 5.3L V8 GAS		AUTOMATIC TRANS. RATINGS 6.0L V8 GAS	
	AXLE RATIO	MAX. TRAILER WEIGHT	AXLE RATIO	MAX. TRAILER WEIGHT	AXLE RATIO	MAX. TRAILER WEIGHT	AXLE RATIO	MAX. TRAILER WEIGHT
C15703	3.08 3.42	4600 5100	3.42 3.73	6500 7500	3.42 3.73	7500 8500		
C15903	3.08 3.42	4400 4900	3.42 3.73	6300 7300	3.42 3.73	7300 8300		
C15753	3.42 3.73	4700 5200	3.42 3.73	6100 7100	3.42 3.73	7100 8100		
C15753 & NYS					3.73 4.10	7700 8700		
C15753 & HP2					3.73	7800		
C15953			3.42 3.73	5900 6900	3.42 3.73	6900 7900		
C15543					3.42 3.73	6800 7800		
C25903 & C6P							3.73 4.10	8800 10800
C25743							3.73 4.10	8300 10300
C25743 & NYS							3.73 4.10	8000 10000

NOTES: Trailer ratings are calculated assuming a standard equipped vehicle plus driver. Optional equipment, passengers or cargo will reduce trailering capacity. C15 models are limited to 5,000-lb. trailer rating unless equipped with Z85 Increased Capacity or ZX3 Manual Select Damping or Z71 Off-Road Suspension Package. Trailer tongue weight should be 10 to 15% of total loaded trailer weight up to 1,000 lbs. on C15 models and up to 1,500 lbs. on C25 models. Trailering capacity may be limited by tow vehicle ability to carry trailer tongue weight. Addition of trailer tongue weight cannot cause vehicle weights to exceed Rear Gross Axle Weight Rating (RGAWR) or Gross Vehicle Weight Rating (GVWR). Base cooling system includes all content required to attain maximum trailer rating. Z82 Heavy Duty Trailering Equipment Package includes trailer hitch platform, trailer electrical connector and suspension upgrade if necessary.

SPECIAL APPLICATIONS

K 15/25 Series Light Duty Pickup Models (Automatic Transmission) (Chevy Silverado and GMC Sierra)

Weight carrying hitch limit: 5,000-lb. trailer with 600-lb. tongue weight.
 Weight distributing hitch and sway control required over 5,000-lb. trailer weight.

MODEL	AUTOMATIC TRANS. RATINGS 4.3L V6 GAS		AUTOMATIC TRANS. RATINGS 4.8L V8 GAS		AUTOMATIC TRANS. RATINGS 5.3L V8 GAS		AUTOMATIC TRANS. RATINGS 6.0L V8 GAS	
	AXLE RATIO	MAX. TRAILER WEIGHT	AXLE RATIO	MAX. TRAILER WEIGHT	AXLE RATIO	MAX. TRAILER WEIGHT	AXLE RATIO	MAX. TRAILER WEIGHT
K15703	3.42	4800	3.73	7200	3.73	8200		
	3.73	5300	4.10	8200	4.10	9200		
K15903	3.42	4600	3.73	7000	3.73	8000		
	3.73	5100	4.10	8000	4.10	9000		
K15753			3.73	6800	3.73	7800		
			4.10	7800	4.10	8800		
K15753 & NYS					3.73	7400		
					4.10	8400		
K15753 & HP2					3.73	7500		
K15753 & B4U					3.73	7600		
K15753 & Y91							4.10	10000
K15953			3.73	6600	3.73	7600		
			4.10	7600	4.10	8600		
K15543					3.73	7500		
					4.10	8500		

NOTES: Trailer ratings are calculated assuming a standard equipped vehicle plus driver. Optional equipment, passengers or cargo will reduce trailering capacity. K15 models are limited to 5,000-lb. trailer rating unless equipped with Z85 Increased Capacity or ZX3 Manual Select Damping or Z71 Off-Road Suspension Package. Trailer tongue weight should be 10 to 15% of total loaded trailer weight up to 1,000 lbs. on K15 models and up to 1,500 lbs. on K25 models. Trailering capacity may be limited by tow vehicle ability to carry trailer tongue weight. Addition of trailer tongue weight cannot cause vehicle weights to exceed Rear Gross Axle Weight Rating (RGAWR) or Gross Vehicle Weight Rating (GVWR). Base cooling system includes all content required to attain maximum trailer rating. Z82 Heavy Duty Trailering Equipment Package includes trailer hitch platform, trailer electrical connector and suspension upgrade if necessary.

K 15/25 Series Light Duty Pickup Models (continued on next page)

SPECIAL APPLICATIONS

K 15/25 Series Light Duty Pickup Models (Automatic Trans.) (Chevy Silverado and GMC Sierra) (continued from previous page)

Weight carrying hitch limit: 5,000-lb. trailer with 600-lb. tongue weight.
 Weight distributing hitch and sway control required over 5,000-lb. trailer weight.

MODEL	AUTOMATIC TRANS. RATINGS 4.3L V6 GAS		AUTOMATIC TRANS. RATINGS 4.8L V8 GAS		AUTOMATIC TRANS. RATINGS 5.3L V8 GAS		AUTOMATIC TRANS. RATINGS 6.0L V8 GAS	
	AXLE RATIO	MAX. TRAILER WEIGHT	AXLE RATIO	MAX. TRAILER WEIGHT	AXLE RATIO	MAX. TRAILER WEIGHT	AXLE RATIO	MAX. TRAILER WEIGHT
K25753 & C6P							3.73 4.10	8300 10300
K25743							3.73 4.10	8000 10000
K25743 & NYS							3.73 4.10	7700 9700

NOTES: Trailer ratings are calculated assuming a standard equipped vehicle plus driver. Optional equipment, passengers or cargo will reduce trailering capacity. K15 models are limited to 5,000-lb. trailer rating unless equipped with Z85 Increased Capacity or ZX3 Manual Select Damping or Z71 Off-Road Suspension Package. Trailer tongue weight should be 10 to 15% of total loaded trailer weight up to 1,000 lbs. on K15 models and up to 1,500 lbs. on K25 models. Trailering capacity may be limited by tow vehicle ability to carry trailer tongue weight. Addition of trailer tongue weight cannot cause vehicle weights to exceed Rear Gross Axle Weight Rating (RGAWR) or Gross Vehicle Weight Rating (GVWR). Base cooling system includes all content required to attain maximum trailer rating. Z82 Heavy Duty Trailering Equipment Package includes trailer hitch platform, trailer electrical connector and suspension upgrade if necessary.

SPECIAL APPLICATIONS

C/K 25 Series Heavy Duty Pickup Models (Chevy Silverado and GMC Sierra)

Weight carrying hitch limit: 7,500-lb. trailer with 1,000-lb. tongue weight.
 Weight distributing hitch and sway control required over 7,500-lb. trailer weight.

MODEL	AUTO. OR MANUAL TRANS. RATINGS 6.0L V8 GAS		AUTO. OR MANUAL TRANS. RATINGS 8.1L V8 GAS		AUTO. OR MANUAL TRANS. RATINGS 6.6L V8 TURBO DIESEL	
	AXLE RATIO	MAX. TRAILER WEIGHT	AXLE RATIO	MAX. TRAILER WEIGHT	AXLE RATIO	MAX. TRAILER WEIGHT
C25903	4.10	10600	3.73 4.10	12000 12000	3.73	12000
C25753	4.10	10300	3.73 4.10	12000 12000	3.73	12000
C25953	4.10	10200	3.73 4.10	12000 12000	3.73	12000
C25743	4.10	10200	3.73 4.10	12000 12000	3.73	12000
C25943	4.10	10000	3.73 4.10	12000 12000	3.73	12000
K25903	4.10	10300	3.73 4.10	12000 12000	3.73	12000
K25753	4.10	10100	3.73 4.10	12000 12000	3.73	12000
K25953	4.10	9900	3.73 4.10	12000 12000	3.73	12000
K25743	4.10	9900	3.73 4.10	12000 12000	3.73	12000
K25943	4.10	9700	3.73 4.10	12000 12000	3.73	12000

NOTES: Trailer ratings are calculated assuming a standard equipped vehicle plus driver. Optional equipment, passengers or cargo will reduce trailering capacity. Trailer tongue weight should be 10 to 15% of total loaded trailer weight up to 1,500 lbs. Trailering capacity may be limited by tow vehicle ability to carry trailer tongue weight. Addition of trailer tongue weight cannot cause vehicle weights to exceed Rear Gross Axle Weight Rating (RGAWR) or Gross Vehicle Weight Rating (GVWR). L18 engine and 3.73 axle ratio available only with automatic transmission. Base cooling system includes all content required to attain maximum trailer rating. Z82 Heavy Duty Trailering Equipment Package includes trailer hitch platform and trailer electrical connector.

SPECIAL APPLICATIONS

C/K 35 Series Heavy Duty Pickup Models (Chevy Silverado and GMC Sierra)

Weight carrying hitch limit: 7,500-lb. trailer with 1,000-lb. tongue weight.
 Weight distributing hitch and sway control required over 7,500-lb. trailer weight.

MODEL	AUTO. OR MANUAL TRANS. RATINGS 6.0L V8 GAS		AUTO. OR MANUAL TRANS. RATINGS 8.1L V8 GAS		AUTO. OR MANUAL TRANS. RATINGS 6.6L V8 TURBO DIESEL	
	AXLE RATIO	MAX. TRAILER WEIGHT	AXLE RATIO	MAX. TRAILER WEIGHT	AXLE RATIO	MAX. TRAILER WEIGHT
C35953	4.10	9800	4.10	12000	3.73	12000
C35943	4.10	9600	4.10	12000	3.73	12000
K35903	4.10	10100	4.10	12000	3.73	12000
K35903 & R05	4.10	9900	4.10	12000	3.73	12000
K35953	4.10	9700	4.10	12000	3.73	12000
K35953 & R05	4.10	9500	4.10	12000	3.73	12000
K35943	4.10	9500	4.10	12000	3.73	12000
K35943 & R05	4.10	9300	4.10	12000	3.73	12000

NOTES: Trailer ratings are calculated assuming a standard equipped vehicle plus driver. Optional equipment, passengers or cargo will reduce trailering capacity. Trailer tongue weight should be 10 to 15% of total loaded trailer weight up to 1,500 lbs. Trailering capacity may be limited by tow vehicle ability to carry trailer tongue weight. Addition of trailer tongue weight cannot cause vehicle weights to exceed Rear Gross Axle Weight Rating (RGAWR) or Gross Vehicle Weight Rating (GVWR). Base cooling system includes all content required to attain maximum trailer rating. Z82 Heavy Duty Trailering Equipment Package includes trailer hitch platform and trailer electrical connector.

SPECIAL APPLICATIONS

C/K Utility Models (Chevy Tahoe/Suburban and GMC Yukon/Yukon XL)

Weight carrying hitch limit: 5,000-lb. trailer with 600-lb. tongue weight.
 Weight distributing hitch and sway control required over 5,000-lb. trailer weight.

MODEL	AUTOMATIC TRANS. RATINGS 4.8L V8 GAS		AUTOMATIC TRANS. RATINGS 5.3L V8 GAS		AUTOMATIC TRANS. RATINGS 6.0L V8 GAS		AUTOMATIC TRANS. RATINGS 8.1L V8 GAS	
	AXLE RATIO	MAX. TRAILER WEIGHT	AXLE RATIO	MAX. TRAILER WEIGHT	AXLE RATIO	MAX. TRAILER WEIGHT	AXLE RATIO	MAX. TRAILER WEIGHT
C15706	3.42 3.73	5700 6700	3.42 3.73	6700 7700				
C15906			3.73 4.10	7400 8400				
K15706	3.73 4.10	6400 7400	3.73 4.10	7500 7800				
K15906			3.73 4.10	7200 8200				
C25906					3.73 4.10	7900 9900	3.73 4.10	10500 12000
C25906 & NYS					3.73 4.10	7600 9600		
K25906					3.73 4.10	7600 9600	3.73 4.10	10200 12000
K25906 & NYS					3.73 4.10	7300 9300		

NOTES: Trailer ratings are calculated assuming a standard equipped vehicle plus driver. Optional equipment, passengers or cargo will reduce trailer rating. C/K25906 models with Z83 Suspension Package and either 3.73 or 4.10 axle ratio are limited to the 3.73 ratings shown above. Trailer tongue weight should be 10 to 15% of total loaded trailer weight up to 1,000 lbs. on C/K15 models, and up to 1,500 lbs. on C/K25 models. Trailering capacity may be limited by tow vehicle ability to carry trailer tongue weight. Addition of trailer tongue weight cannot cause vehicle weights to exceed Rear Gross Axle Weight Rating (RGAWR) or Gross Vehicle Weight Rating (GVWR). Base cooling system includes all content required to attain maximum trailer rating. Z82 Heavy Duty Trailering Equipment Package includes trailer hitch platform and trailer electrical connector. K15706 European Export trailer rating is 3,500 kg; weight distribution and sway control not required.

SPECIAL APPLICATIONS

C/K Luxury Utility Models (Cadillac Escalade/Escalade ESV and GMC Yukon Denali/Yukon XL Denali)

Weight carrying hitch limit: 5,000-lb. trailer with 600-lb. tongue weight.
 Weight distributing hitch and sway control required over 5,000-lb. trailer weight.

MODEL	AUTOMATIC TRANSMISSION RATINGS 5.3L V8 GAS		AUTOMATIC TRANSMISSION RATINGS 6.0L V8 GAS	
	AXLE RATIO	MAX. TRAILER WEIGHT	AXLE RATIO	MAX. TRAILER WEIGHT
C15706 & Z75	3.73	7400		
K15706 & Y91			3.73	8200
K15706 & Z75			3.73	8100
K15906 & Y91			3.73	8000
K15906 & Z75			3.73	7700
K15906 & Z75 & ULT			3.73	7300

NOTES: Trailer ratings are calculated assuming a standard equipped vehicle plus driver. Optional equipment, passengers or cargo will reduce trailer rating. Trailer tongue weight should be 10 to 15% of total loaded trailer weight up to 1,000 lbs. Trailering capacity may be limited by tow vehicle ability to carry trailer tongue weight. Addition of trailer tongue weight cannot cause vehicle weights to exceed Rear Gross Axle Weight Rating (RGAWR) or Gross Vehicle Weight Rating (GVWR). Base cooling system includes all content required to attain maximum trailer rating. Z82 Heavy Duty Trailering Equipment Package includes trailer hitch platform and trailer electrical connector.

SPECIAL APPLICATIONS

C/K Ultimate Utility Models (Cadillac Escalade EXT and Chevy Avalanche)

Weight carrying hitch limit: 5,000-lb. trailer with 600-lb. tongue weight.
 Weight distributing hitch and sway control required over 5,000-lb. trailer weight.

MODEL	AUTOMATIC TRANSMISSION RATINGS 5.3L V8 GAS		AUTOMATIC TRANSMISSION RATINGS 6.0L V8 GAS		AUTOMATIC TRANSMISSION RATINGS 8.1L V8 GAS	
	AXLE RATIO	MAX. TRAILER WEIGHT	AXLE RATIO	MAX. TRAILER WEIGHT	AXLE RATIO	MAX. TRAILER WEIGHT
C15936	3.73 4.10	7300 8300				
K15936	3.73 4.10	7100 8000				
K15936 & Z75			3.73	7400		
C25936					3.73 4.10	10400 12000
K25936					3.73 4.10	10100 12000

NOTES: Trailer ratings are calculated assuming a standard equipped vehicle plus driver. Optional equipment, passengers or cargo will reduce trailer rating. Ultimate utility models are neither designed nor intended to tow 5th wheel or gooseneck trailers. Trailer tongue weight should be 10 to 15% of total loaded trailer weight up to 1,000 lbs. on C/K15 models and up to 1,500 lbs. on C/K25 models. Trailering capacity may be limited by tow vehicle ability to carry trailer tongue weight. Addition of trailer tongue weight cannot cause vehicle weights to exceed Rear Gross Axle Weight Rating (RGAWR) or Gross Vehicle Weight Rating (GVWR). Base cooling system includes all content required to attain maximum trailer rating. Z82 Heavy Duty Trailering Equipment Package includes trailer hitch platform and trailer electrical connector.

SPECIAL APPLICATIONS

H2 Utility Models (Hummer)

Weight carrying hitch limit: 5,000-lb. trailer with 500-lb. tongue weight.
Weight distributing hitch and sway control required over 5,000-lb. trailer weight.

MODEL	AUTOMATIC TRANSMISSION RATINGS 6.0L V8 GAS	
	AXLE RATIO	MAX. TRAILER WEIGHT
N25706	4.10	6700

NOTES: Trailer ratings are calculated assuming a standard equipped vehicle plus driver. Optional equipment, passengers or cargo will reduce trailering capacity. Trailer tongue weight should be 10 to 15% of total loaded trailer weight up to 700 lbs. Trailering capacity may be limited by tow vehicle ability to carry trailer tongue weight. Addition of trailer tongue weight cannot cause vehicle weights to exceed Rear Gross Axle Weight Rating (RGAWR) or Gross Vehicle Weight Rating (GVWR). Base cooling system includes all content required to attain maximum trailer rating.

SPECIAL APPLICATIONS

M/L Van Models (Chevy Astro and GMC Safari)

Weight carrying hitch limit: 2,000-lb. trailer with 200-lb. tongue weight.
Weight distributing hitch and sway control required over 2,000-lb. trailer weight.

MODEL	AUTOMATIC TRANSMISSION RATINGS 4.3L V6 GAS	
	AXLE RATIO	MAX. TRAILER WEIGHT
M11005	3.42	5200
	3.73	5700
M11006	3.42	4900
	3.73	5400
L11005	3.42	5000
	3.73	5500
L11006	3.42	4600
	3.73	5100

NOTES: Trailer ratings are calculated assuming a standard equipped vehicle plus driver. Optional equipment, passengers or cargo will reduce trailering capacity. Trailer tongue weight should be 10 to 15% of total loaded trailer weight up to 750 lbs. Trailering capacity may be limited by tow vehicle ability to carry trailer tongue weight. Addition of trailer tongue weight cannot cause vehicle weights to exceed Rear Gross Axle Weight Rating (RGAWR) or Gross Vehicle Weight Rating (GVWR). Base cooling system includes all content required to attain maximum trailer rating. No optional cooling equipment available. Z82 Heavy Duty Trailering Equipment Package includes weight distributing hitch platform and 8-wire trailer wiring harness.

SPECIAL APPLICATIONS

G/H Van (GMT610) Models (Chevy Express and GMC Savana)

Weight carrying hitch limit: 4,000-lb. trailer with 400-lb. tongue weight.
 Weight distributing hitch and sway control required over 4,000-lb. trailer weight.

MODEL	AUTOMATIC TRANS. RATINGS 4.3L V6 GAS		AUTOMATIC TRANS. RATINGS 4.8L V8 GAS		AUTOMATIC TRANS. RATINGS 5.3L V8 GAS		AUTOMATIC TRANS. RATINGS 6.0L V8 GAS	
	AXLE RATIO	MAX. TRLR. WEIGHT	AXLE RATIO	MAX. TRLR. WEIGHT	AXLE RATIO	MAX. TRLR. WEIGHT	AXLE RATIO	MAX. TRLR. WEIGHT
G13405	3.42	4400			3.42 3.73	6600 6600		
H13405					3.42 3.73	6600 6600		
G13406	3.42	4000			3.42 3.73	6400 6400		
H13406					3.42 3.73	6200 6200		
G23405	3.73	4700	3.73 4.10	6400 7400	3.73	6600	3.73 4.10	8400 10000
H23405					3.73	6400		
G23705	3.73	4500	3.73 4.10	6300 7300	3.73	6500	3.73 4.10	8200 10000
G23406							3.73 4.10	7900 9900
G23706							3.73 4.10	7500 9500

NOTES: Trailer ratings are calculated assuming a standard equipped vehicle plus driver. Optional equipment, passengers or cargo will reduce trailering capacity. Trailer tongue weight should be 10 to 15% of total loaded trailer weight up to 1,000 lbs. Trailering capacity may be limited by tow vehicle ability to carry trailer tongue weight. Addition of trailer tongue weight cannot cause vehicle weights to exceed Rear Gross Axle Weight Rating (RGAWR) or Gross Vehicle Weight Rating (GVWR). Base cooling system includes all content required to attain maximum trailer rating. Z82 Heavy Duty Trailering Equipment Package includes weight distributing hitch platform and trailer wiring harness.

SPECIAL APPLICATIONS

G/H Van (GMT610) Models (Chevy Express and GMC Savana) (continued from previous page)

Weight carrying hitch limit: 4,000-lb. trailer with 400-lb. tongue weight.
 Weight distributing hitch and sway control required over 4,000-lb. trailer weight.

MODEL	AUTOMATIC TRANS. RATINGS 4.3L V6 GAS		AUTOMATIC TRANS. RATINGS 4.8L V8 GAS		AUTOMATIC TRANS. RATINGS 5.3L V8 GAS		AUTOMATIC TRANS. RATINGS 6.0L V8 GAS	
	AXLE RATIO	MAX. TRLR. WEIGHT	AXLE RATIO	MAX. TRLR. WEIGHT	AXLE RATIO	MAX. TRLR. WEIGHT	AXLE RATIO	MAX. TRLR. WEIGHT
G33405							3.73 4.10	8300 10000
G33705							3.73 4.10	8100 10000
G33406							3.73 4.10	7800 9800
G33706							3.73 4.10	7400 9400

NOTES: Trailer ratings are calculated assuming a standard equipped vehicle plus driver. Optional equipment, passengers or cargo will reduce trailering capacity. Trailer tongue weight should be 10 to 15% of total loaded trailer weight up to 1,000 lbs. Trailering capacity may be limited by tow vehicle ability to carry trailer tongue weight. Addition of trailer tongue weight cannot cause vehicle weights to exceed Rear Gross Axle Weight Rating (RGAWR) or Gross Vehicle Weight Rating (GVWR). Base cooling system includes all content required to attain maximum trailer rating. Z82 Heavy Duty Trailering Equipment Package includes weight distributing hitch platform and trailer wiring harness.

SPECIAL APPLICATIONS

C/K 25 Series Dedicated CNG or CNG/Gas Bi-Fuel Pickup Models (Chevy Silverado and GMC Sierra)

Weight carrying hitch limit: 5,000-lb. trailer with 600-lb. tongue weight.
 Weight distributing hitch and sway control required over 5,000-lb. trailer weight.

MODEL	AUTOMATIC TRANSMISSION RATINGS 6.0L V8 ALT. FUEL	
	AXLE RATIO	MAX. TRAILER WEIGHT
C25903 & KL6	3.73	6900
	4.10	7900
C25903 & KL8	3.73	7200
	4.10	8200
C25953 & KL6	3.73	6500
	4.10	7500
C25953 & KL8	3.73	6800
	4.10	7800
K25903 & KL6	3.73	6600
	4.10	7600
K25903 & KL8	3.73	6900
	4.10	7900
K25953 & KL6	3.73	6200
	4.10	7200
K25953 & KL8	3.73	6500
	4.10	7500
K25943 & KL6	4.10	7000

NOTES: Trailer ratings are calculated assuming a standard equipped vehicle plus driver. Optional equipment, passengers or cargo will reduce trailering capacity. Trailer tongue weight should be 10 to 15% of total loaded trailer weight. Trailering capacity may be limited by tow vehicle ability to carry trailer tongue weight. Addition of trailer tongue weight cannot cause vehicle weights to exceed Rear Gross Axle Weight Rating (RGAWR) or Gross Vehicle Weight Rating (GVWR). Alternate fuel vehicles are neither designed nor intended to tow 5th wheel or gooseneck trailers. Base cooling system includes all content required to attain maximum trailer rating. Z82 Heavy Duty Trailering Equipment Package includes trailer hitch platform and trailer electrical connector.

SPECIAL APPLICATIONS

G/H Dedicated CNG or CNG/Gas Bi-Fuel Van Models (Chevy Express and GMC Savana)

Weight carrying hitch limit: 4,000-lb. trailer with 400-lb. tongue weight.
 Weight distributing hitch and sway control required over 4,000-lb. trailer weight.

MODEL	AUTOMATIC TRANSMISSION RATINGS 6.0L V8 ALT. FUEL		
	AXLE RATIO	MAX. TRAILER WEIGHT	
		KL6	KL8
G23405	3.73	7100	7400
G23705	3.73	6900	7200
G23406	3.73	6500	6800
G33405	3.73	6900	7200
G33705	3.73	6600	6800
G33406	3.73	6400	6700
G33706	3.73	6000	6300

NOTES: Trailer ratings are calculated assuming a standard equipped vehicle plus driver. Optional equipment, passengers or cargo will reduce trailering capacity. Trailer tongue weight should be 10 to 15% of total loaded trailer weight up to 1,000 lbs. Trailering capacity may be limited by tow vehicle ability to carry trailer tongue weight. Addition of trailer tongue weight cannot cause vehicle weights to exceed Rear Gross Axle Weight Rating (RGAWR) or Gross Vehicle Weight Rating (GVWR). Base cooling system includes all content required to attain maximum trailer rating. Z82 Heavy Duty Trailering Equipment Package includes weight distributing hitch platform and trailer wiring harness.

2004 Maximum Trailer Ratings 5th Wheel or Gooseneck Trailer Ratings

C 15/25 Series Light Duty Pickup Models (Chevy Silverado and GMC Sierra)

5th Wheel or Gooseneck Trailer Ratings

MODEL	AUTOMATIC TRANSMISSION RATINGS 4.8L V8 GAS		AUTOMATIC TRANSMISSION RATINGS 5.3L V8 GAS		AUTO. OR MANUAL TRANS. RATINGS 6.0L V8 GAS	
	AXLE RATIO	MAX. TRAILER WEIGHT	AXLE RATIO	MAX. TRAILER WEIGHT	AXLE RATIO	MAX. TRAILER WEIGHT
C15703	3.42	6500	3.42	7500		
	3.73	7500	3.73	8500		
C15903	3.42	6300	3.42	7300		
	3.73	7300	3.73	8300		
C15753	3.42	6100	3.42	7100		
	3.73	7100	3.73	8100		
C15953	3.42	5900	3.42	6900		
	3.73	6900	3.73	7900		
C25903 & C6P					3.73	8800
					4.10	10800
C25743					3.73	8300
					4.10	10300

NOTES: Trailer ratings are calculated assuming a standard equipped vehicle plus driver. Optional equipment, passengers or cargo will reduce trailering capacity. C15 models with 4.3L engine or 4.8L engine and manual transmission are not rated to tow 5th wheel or gooseneck trailers. Parallel hybrid vehicles are neither designed nor intended to tow 5th wheel or gooseneck trailers. C15543 vehicles are neither designed nor intended to tow 5th wheel or gooseneck trailers. 4-wheel steer vehicles cannot be purchased with 5th wheel trailer wiring harness. C15 models require Z85 Increased Capacity or ZX3 Manual Select Damping Suspension Package to tow 5th wheel or gooseneck trailers. Trailer kingpin weight should be 15 to 25% of total loaded trailer weight up to 1,500 lbs. on C15 models, and up to 2,500 lbs. on C25 models. Trailering capacity may be limited by tow vehicle ability to carry trailer kingpin weight. Addition of trailer kingpin weight cannot cause vehicle weights to exceed Rear Gross Axle Weight Rating (RGAWR) or Gross Vehicle Weight Rating (GVWR). Base cooling system includes all content required to attain maximum trailer rating. 5th wheel hitch is available as a dealer-installed accessory.

C/K 15/25 Series Light Duty Pickup Models (continued on next page)

SPECIAL APPLICATIONS

K 15/25 Series Light Duty Pickup Models (Chevy Silverado and GMC Sierra) (continued from previous page)

5th Wheel or Gooseneck Trailer Ratings

MODEL	AUTOMATIC TRANSMISSION RATINGS 4.8L V8 GAS		AUTOMATIC TRANSMISSION RATINGS 5.3L V8 GAS		AUTO. OR MANUAL TRANS. RATINGS 6.0L V8 GAS	
	AXLE RATIO	MAX. TRAILER WEIGHT	AXLE RATIO	MAX. TRAILER WEIGHT	AXLE RATIO	MAX. TRAILER WEIGHT
K15703	3.73 4.10	7200 8100	3.73 4.10	8100 8100		
K15903	3.73 4.10	7000 8000	3.73 4.10	8000 9000		
K15753	3.73 4.10	6800 7800	3.73 4.10	7800 7800		
K15953	3.73 4.10	6600 6800	3.73 4.10	6800 6800		
K25753 & C6P					3.73 4.10	8300 10300
K25743					3.73 4.10	8000 10000

NOTES: Trailer ratings are calculated assuming a standard equipped vehicle plus driver. Optional equipment, passengers or cargo will reduce trailering capacity. K15 models with 4.3L engine or 4.8L engine and manual transmission are not rated to tow 5th wheel or gooseneck trailers. Parallel hybrid vehicles are neither designed nor intended to tow 5th wheel or gooseneck trailers. C15543 vehicles are neither designed nor intended to tow 5th wheel or gooseneck trailers. 4-wheel steer vehicles cannot be purchased with 5th wheel trailer wiring harness. K15 models require Z85 Increased Capacity or ZX3 Manual Select Damping Suspension Package to tow 5th wheel or gooseneck trailers. Trailer kingpin weight should be 15 to 25% of total loaded trailer weight up to 1,500 lbs. on K15 models, and up to 2,500 lbs. on K25 models. Trailering capacity may be limited by tow vehicle ability to carry trailer kingpin weight. Addition of trailer kingpin weight cannot cause vehicle weights to exceed Rear Gross Axle Weight Rating (RGAWR) or Gross Vehicle Weight Rating (GVWR). Base cooling system includes all content required to attain maximum trailer rating. 5th wheel hitch is available as a dealer-installed accessory.

SPECIAL APPLICATIONS

C/K 25 Series Heavy Duty Pickup Models (Chevy Silverado and GMC Sierra)

5th Wheel or Gooseneck Trailer Ratings

MODEL	AUTO. OR MANUAL TRANS. RATINGS 6.0L V8 GAS		AUTO. OR MANUAL TRANS. RATINGS 8.1L V8 GAS		AUTO. OR MANUAL TRANS. RATINGS 6.6L V8 TURBO DIESEL	
	AXLE RATIO	MAX. TRAILER WEIGHT	AXLE RATIO	MAX. TRAILER WEIGHT	AXLE RATIO	MAX. TRAILER WEIGHT
C25903	4.10	10600	3.73 4.10	14100 16100	3.73	15900
C25753	4.10	10300	3.73 4.10	13900 15900	3.73	15700
C25953	4.10	10200	3.73 4.10	13700 15700	3.73	15500
C25743	4.10	10200	3.73 4.10	13700 15700	3.73	15500
C25943	4.10	10000	3.73 4.10	13500 15500	3.73	15300
K25903	4.10	10300	3.73 4.10	13900 15900	3.73	15700
K25753	4.10	10100	3.73 4.10	13600 15600	3.73	15400
K25953	4.10	9900	3.73 4.10	13500 15500	3.73	15300
K25743	4.10	9800	3.73 4.10	13400 15400	3.73	14900
K25943	4.10	9700	3.73 4.10	13200 14700	3.73	13800

NOTES: Trailer ratings are calculated assuming a standard equipped vehicle plus driver. Optional equipment, passengers or cargo will reduce trailering capacity. Trailer kingpin weight should be 15 to 25% of total loaded trailer weight up to 3,000 lbs. Trailering capacity may be limited by tow vehicle ability to carry trailer kingpin weight. Addition of trailer kingpin weight cannot cause vehicle weights to exceed Rear Gross Axle Weight Rating (RGAWR) or Gross Vehicle Weight Rating (GVWR). Base cooling system includes all content required to attain maximum trailer rating. L18 engine and 3.73 axle ratio available only with automatic transmission.

SPECIAL APPLICATIONS

C/K 35 Series Heavy Duty Pickup Models (Chevy Silverado and GMC Sierra)

5th Wheel or Gooseneck Trailer Ratings

MODEL	AUTO. OR MANUAL TRANS. RATINGS 6.0L V8 GAS		AUTO. OR MANUAL TRANS. RATINGS 8.1L V8 GAS		AUTO. OR MANUAL TRANS. RATINGS 6.6L V8 TURBO DIESEL	
	AXLE RATIO	MAX. TRAILER WEIGHT	AXLE RATIO	MAX. TRAILER WEIGHT	AXLE RATIO	MAX. TRAILER WEIGHT
C35953	4.10	9800	4.10	15400	3.73	15200
C35943	4.10	9600	4.10	15200	3.73	15000
K35903	4.10	10100	4.10	15700	3.73	15500
K35903 & R05	4.10	9900	4.10	15500	3.73	15300
K35953	4.10	9700	4.10	15300	3.73	15200
K35953 & R05	4.10	9500	4.10	15100	3.73	14900
K35943	4.10	9500	4.10	15100	3.73	14900
K35943 & R05	4.10	9300	4.10	14900	3.73	14600

NOTES: Trailer ratings are calculated assuming a standard equipped vehicle plus driver. Optional equipment, passengers or cargo will reduce trailering capacity. Trailer kingpin weight should be 15 to 25% of total loaded trailer weight up to 3,500 lbs. Trailering capacity may be limited by tow vehicle ability to carry trailer kingpin weight. Addition of trailer kingpin weight cannot cause vehicle weights to exceed Rear Gross Axle Weight Rating (RGAWR) or Gross Vehicle Weight Rating (GVWR). Base cooling system includes all content required to attain maximum trailer rating.

TRAILERING ELECTRICAL INFORMATION

Trailer Harness Release		
Model	Standard	Optional
S/T Pickup	N/A	N/A
S/T Utility	Six-Wire	Eight-Wire (UY7, part of Z82)
M/L Van	Six-Wire	Eight-Wire (UY7, part of Z82)
C/K Truck (Current)	Eight-Wire	N/A
G Van	N/A	Eight-Wire (UY7, part of Z82)

Trailer Harness Wire Colors	
Wire Color	Wire Usage
Blue	Electric trailer brakes or auxiliary wiring
Red/Orange	Battery charging
Light Green	Backup lamps
Brown	Tail lamps and running lamps
Yellow	Left, stop and turn signal
Dark Green	Right, stop and turn signal
Thick White	Ground
Thin White (M/L) (G) / Light Blue (S/T) (C/K)	Independent stop lamp (CHMSL)

Vehicle to Trailer Electrical System Setup					
Model	Junction Block Location (Battery Feed)	Brake Pedal Switch Splice Location	Interior Ground Location	Forward Trailer Harness Location	Rear Trailer Harness Location
C/K Truck (Current)	Underhood electrical center stud, left rear corner behind washer bottle.	Under dash at brake pedal switch (white wire).	No interior ground. Use engine block or negative battery terminal.	Engine compartment, near brake booster. Orange and blue wires strapped together.	Pickups: in front of license plate area of rear bumper (except battery charge, trailer brake and independent stop wires taped back at left frame rail). Utilities: inside left lower quarter panel. Cut straps and route harness over frame rail.
G Van	Underhood electrical center stud, left rear corner behind washer bottle.	Under dash at brake pedal switch (white wire).	No interior ground. Use engine block or negative battery terminal.	Engine compartment, near brake booster. Red and blue wires strapped together.	Inside vehicle, right rear corner, in jack compartment (above jack).
M/L Van	Front of dash, left side under steering column (covered).	Under dash at brake pedal switch (white wire).	Under left side trim panel. Use self-tapping screw and ring terminal to plenum side panel.	Passenger compartment, under dash. Orange and blue wires strapped together.	Inside vehicle, right rear corner, in jack compartment (behind jack).
S/T Truck	Underhood electrical center stud near left front fender (covered).	Under dash at brake pedal switch (white wire).	No interior ground. Use engine block or negative battery terminal.	Engine compartment, near underhood electrical center. Red and blue wires strapped together. N/A for pickups.	Inside left frame rail.

General Information

To provide battery charging to the trailer, place ring terminal on red (or orange) wire over one of the junction block studs. When installing an electrical connector to the vehicle's trailer wiring harness, follow the color codes shown in the chart above.