

2005 & BEYOND C/K FULL SIZE TRUCKS (PICKUPS, UTILITIES AND CHASSIS-CABS)

BODY BUILDERS INSTRUCTIONS	1
Section 0 – General Instructions	1
Section 1 – Body	2
Conversions	3
Air Conditioning	3
Rear Air Conditioning	3
Section 2 – Frame	4
Flanges	4
Holes	4
Welding	5
Alterations	5
Shear Plate Attachments	5
Section 3 – Front Suspension	6
Section 4 – Rear Suspension	6
Section 5 – Brakes	6
Section 6 – Engine	7
Section 7 – Transmission	9
Powertrain Specifications and Line-Up Charts	10
Specifications – Automatic Transmissions	10
Automatic Transmission/Engine Availability Matrix	10
Specifications – Manual Transmissions	11
Section 8 – Fuel and Exhaust	11
Fuel Systems	11
Fuel Fill	12
Fuel Lines	12
Fuel Tank	13
Gaseous Fuel Conversions	13

2005 & BEYOND C/K FULL SIZE TRUCKS (PICKUPS, UTILITIES AND CHASSIS-CABS)

BODY BUILDERS INSTRUCTIONS – *Continued*

Exhaust System	14
Section 9 – Steering	15
Section 10 – Tires	15
Section 12 – Electrical Battery and Battery Cables	15
Auxiliary Battery (Gasoline Engines Only)	16
Section 13 – Cooling	17
Model Symbol Chart	18
FRAME HEIGHTS AND RAMP ANGLES	See Section Following G/H Van
TRUCK CAMPER LOADING	See Special Applications
C/K SNOWPLOW PREP	See Special Applications
C/K PICKUP BOX REMOVAL	See Special Applications
TRAILERING INFORMATION	See Special Applications
CHASSIS	
General Arrangement – C/K (15/25)703	20
General Arrangement – C/K 15706	21
General Arrangement – C/K (15/25)906	22
General Arrangement – C/K (15/25)936	23
BODY	
PICKUP: GENERAL ARRANGEMENT, EXTERIOR	
Regular Cab with Short Box (Option E63) – C/K 15703	24
Regular Cab with Long Box (Option E63) – C/K (15/25HD/35)903	25
Regular Cab, Sportside (Option E62) – C/K 15703	26
Extended Cab with Short Box (Option E63) – C/K (15/25HD)753	27
Extended Cab with Long Box (Option E63) – C/K (15/25/25HD/35)953	28
Extended Cab, Sportside (Option E62) – C/K 15753	29

2005 & BEYOND C/K FULL SIZE TRUCKS (PICKUPS, UTILITIES AND CHASSIS-CABS)

BODY, PICKUP: GENERAL ARRANGEMENT, EXTERIOR – *Continued*

Crew Cab with Short Short Box (Option E63) (Chevy) – C/K 15543	30
Crew Cab with Short Short Box (Option E63) (GMC) – C/K 15543	31
Crew Cab with Short Box (Option E63) – C/K (25/25HD)743	32
Crew Cab with Long Box (Option E63) – C/K (25HD/35)943	33
Regular Cab with Long Box Dooley (Option E63) – C/K 35903	34
Extended Cab with Long Box Dooley (Option E63) – C/K 35953	35
Crew Cab with Long Box Dooley (Option E63) – C/K 35943	36

CHASSIS CAB: GENERAL ARRANGEMENT, EXTERIOR

Regular Cab (Option ZW9) – C/K 25HD/K35903	37
K 35953 w/ZW9	38
Crew Cab (Option ZW9) – C/K 25HD/35943	39
Regular Cab (Option ZW9) – C/K 36(0/4)03	40
Extended Cab (Option ZW9) – C/K 36(0/4)53	41

UTILITY: GENERAL ARRANGEMENT, EXTERIOR

Tahoe/Yukon – C/K 15706	42
Suburban/Yukon XL – C/K (15/25)906	43
Avalanche – C/K (15/25)936	44

CHASSIS CAB: WHEELBASE AND CA'S

Regular Cab CA's – C/K (25HD/35/36)	45
Extended Cab CA's – C/K (25HD/35/36)	46
Crew Cab CA's – C/K (25HD/35)	47

CAB INTERIOR

Regular Cab – C/K (15/25)	48
Regular Cab – C/K (25HD/35/36)	49
Extended Cab – C/K (15/25)	50

2005 & BEYOND C/K FULL SIZE TRUCKS (PICKUPS, UTILITIES AND CHASSIS-CABS)

BODY, CAB INTERIOR – *Continued*

Extended Cab – C/K (25HD/35/36)	51
Crew Cab – C/K (15/25)	52
Crew Cab – C/K (25HD/35/36)	53

SEATING POSITIONS

Regular and Extended Cab – C/K (15/25)	54
Regular and Extended Cab – C/K (25HD/35/36)	55
Crew Cab Second Row – C/K (15/25/25HD/35)(743/943)	56
C/K 15706	57
C/K (15/25)906	58
C/K (15/25)936	59

CAB EXTERIOR

Regular Cab Chevy – C/K (15/25)	60
Regular Cab Chevy – C/K (25HD/35/36)	61
Extended Cab Chevy – C/K (15/25)	62
Extended Cab Chevy – C/K (25HD/35/36)	63
Crew Cab Chevy – C/K (15/25)(43)	64
Crew Cab Chevy – C/K (25HD/35/36)(43)	65

DOOR SWING/OPENINGS

Door Openings – C/K (15/25/25HD/35/36)(03/43/53/06/36)	66
Rear Door Openings – C/K (15/25)(7/9)06	67

FRONT END SHEET METAL

Front End Sheet Metal – Utilities – C/K (157/159/259)(06)	68
Front End Sheet Metal – Pickups and Chassis-Cab – C/K (15/25)	69
Front End Sheet Metal – Pickups and Chassis-Cab – C/K (25HD/35/36)	70
2005 and Beyond MCE Hood and Grille Chevrolet 25HD/35/36	71

2005 & BEYOND C/K FULL SIZE TRUCKS (PICKUPS, UTILITIES AND CHASSIS-CABS)

BODY, FRONT END SHEET METAL – *Continued*

Hood Swing 2005 and Beyond Chevrolet 25HD/35/36	72
Front End Sheet Metal – C/K (15/25)936	73

MIRRORS

Outside, Mirror Options – C/K (15/25)(03/53/06)	74
Outside, Mirror Options – C/K (25HD/35/36)	75
Outside, Mirror Options – C/K (15/25)936	76

BACK OF CAB PROFILE

Back of Cab Profile Nominal – C/K (15/25)(03/53)	77
Back of Cab Profile Nominal – C/K (25HD/35/36)	78

HOODS

Hood Profile – Chevy, Tahoe and Suburban – C/K (15/25)(706/906)	79
Hood Profile – Chevy, 2003 and Beyond MCE C/K 15/25 Chevrolet Pickups	
Hood Profile – Chevy, 2003 MCE and 2004 C/K 25HD/35/36 Chevy Silverado Pickups and Chassis-Cabs.....	80
Hood Profile (Chevy) – C/K (25HD/35/36) 2005 MCE and Beyond	81
Hood Profile (GMC) – C/K (15/25)	82
Hood Profile (GMC) – C/K (25HD/35/36)	83
Hood Profile – C/K (15/25)936	84
Hood Inner Panel – C/K (15/25/25HD/35/36).....	85

PICKUP BOXES

Short Short Fleetside Box – C/K 15543	86
6.5 and 8.0 Foot Fleetside Box – C/K	87
Fleetside 6.5 Foot with Quad Steering (Opt. NYS) – C/K	88
Stake Pockets – C/K (15/25/25HD/35).....	89
2005 and Beyond Pickup Box Electrical Plus Outlet Location – C/K15753, Hybrid Option HPT	90
Fleetside Box, Top Rail – C/K (15/25/25HD/35).....	91

2005 & BEYOND C/K FULL SIZE TRUCKS (PICKUPS, UTILITIES AND CHASSIS-CABS)

BODY, PICKUP BOXES – *Continued*

Short Short Fleetside Box Inner Panel – C/K 15543	92
Fleetside Box Inner Side Panel – C/K (15/25)	93
Box Inner Side Panel – C/K (25HD/35)	94
Sportside Box – C/K 157(03/53)	95
Sportside Box, Top Rail – C/K 157(03/53)	96
Sportside, Inner Side Panel – C/K 157(03/53)	97
Platform Cross Sills – 5' 8.5" Pickup Box – Fleetside (Option E63)	98
Platform Cross Sills – 6.5 Foot Pickup Box – Fleetside (RPO E63), Sportside/Stepside (RPO E62)	99
Platform Cross Sills – 8 Foot Pickup Box – Fleetside (RPO E63)	100
Cargo Area – C/K (15/25)936	101
Cargo Area Inner Side Panel – C/K (15/25)936	102
Side Storage Compartment – C/K (15/25)936	103

MISCELLANEOUS

Luggage Rack and Running Boards – C/K 15706	104
Luggage Rack and Running Boards – C/K (15/25)906	105
Running Board Mounting Location – C/K (15/25)936	106
Clearance Lamps – C/K (25HD/35/36)	107
Pressure Relief Valve Shield – C/K (36)	108
Front Floor Seat Mounting Location – C/K (15/25)	109
Front Floor Seat Mounting Location – C/K (25HD/35/36)	110
Front Floor Structure – C/K (25HD/35/36)	111

FRAME

RAIL AND CROSSMEMBER ARRANGEMENT

C 15703	112
K 15703	113

2005 & BEYOND C/K FULL SIZE TRUCKS (PICKUPS, UTILITIES AND CHASSIS-CABS)

FRAME, RAIL AND CROSSMEMBER ARRANGEMENT – *Continued*

C 15903.....	114
K 15903.....	115
C/K 25903.....	116
C 15753.....	117
K 15753.....	118
C 15953.....	119
K 15953.....	120
C 15543.....	121
K 15543.....	122
C/K 15706.....	123
C/K 15906.....	124
C/K 25906.....	125
C/K 25936.....	126
C/K 25753.....	127
C/K 25953.....	128
FRONT FRAME	
Pickup – C (15)	129
Pickup – C (25)	130
Utility – K (15) Pickup C/K (15)	131
Utility – K (25) Pickup C/K (25)	132
C/K (25HD/35/36)	133
W/Dim – C (25HD/35/36).....	134
W/Dim – K (25HD/35/36).....	135
INTERMEDIATE AND REAR FRAME	
C/K (25HD/K35)903.....	136

2005 & BEYOND C/K FULL SIZE TRUCKS (PICKUPS, UTILITIES AND CHASSIS-CABS)

FRAME, INTERMEDIATE AND REAR FRAME – *Continued*

W/Dim – C/K (25HD/K35)903	137
C/K 25753 HD	138
W/Dim – C/K 25753 HD	139
C/K (25HD/35)953	140
W/Dim – C/K (25HD/35)953	141
C/K 25743 HD	142
W/Dim – C/K 25743 HD	143
C/K (25HD/35)943	144
W/Dim – C/K (25HD/35)943	145
C/K 36003	146
W/Dim – C/K 36003	147
C/K 36403	148
W/Dim – C/K 36403	149
C/K 36053	150
W/Dim – C/K 36053	151
C/K 36453	152
W/Dim – C/K 36453	153
SPARE TIRE CARRIER	
Pickup – C/K (15/25)	154
Utility – C/K (15/25)	155
C/K (25HD/35)	156
PLATFORM HITCH	
Pickup – C/K (15/25)	157
Utility – C/K (15/25)	158
Short Box Pickup – C/K (25HD)	159

2005 & BEYOND C/K FULL SIZE TRUCKS (PICKUPS, UTILITIES AND CHASSIS-CABS)

PLATFORM HITCH- *Continued*

Long Box Pickup – C/K (25HD/35)	160
C/K (15/25)936	161

AXLE SUSPENSION

Front Axle/Tire Data – C/K (15)	162
Front Axle/Tire Data – C/K (15)	163
Front Axle/Tire Data – C/K (15/25)	164
Front Axle/Tire Data – C/K (25HD/35/36)	165
Front Axle/Tire Data – C/K (25HD/35/36)	166
Rear Axle/Tire Data – C/K (15/25)	167
Rear Axle/Tire Data – C/K (15)	168
Rear Axle/Tire Data – C/K (15)	169
Rear Axle/Tire Data – C/K (25)	170
Rear Axle/Tire Data – C/K (25HD/35)	171
Rear Axle/Tire Data – C/K (36)	172

FUEL TANK

26 Gallon Fuel Tank – C/K (15/25)(7)(03/53)	173
34 Gallon Fuel Tank – C/K (15/25)(9)(03/53)	174
26 Gallon Fuel Tank – C/K 15706	175
33 Gallon Fuel Tank – C/K 15906	176
36 Gallon Fuel Tank – C/K 25 (906/936)	177
34 Gallon Fuel Tank – C/K (25HD/35)(9)(03/43/53)	178
23/27 Gallon Fuel Tank – C/K 36	179
C/K 15543 4.3 and 4.8 L Engine and 26 Gallon Fuel Tank	180

EXHAUST

4.3 L V6 Gas Engine, Pickup, Option LU3 and L35	181
---	-----

2005 & BEYOND C/K FULL SIZE TRUCKS (PICKUPS, UTILITIES AND CHASSIS-CABS)

EXHAUST- *Continued*

4.8 L and 5.3 L V8 Gas Engine, Pickup, Option LR4 and LM7	182
6.0 L V8 Gas Engine, Pickup, Option LQ4	183
6.0 L V8 Gas Engine, Pickup, Option LQ4 w/NYS (Quad Steering)	184
5.3 L V8 Gas Engine, Utility, Option LM7	185
6.0 L V8 Gas Engine, Utility, Option LQ4 and LQ9	186
8.1 L V8 Gas Engine, Pickup, Option L18	187
8.1 L V8 Gas Engine, Chassis Cab, Option L18 – C/K 36 (03).....	188
8.1 L V8 Gas Engine, Chassis Cab, Option L18 – C/K 36 (53).....	189
8.1 L V8 Gas Engine, Utility, Option L18 (Federal)	190
8.1 L V8 Gas Engine, Utility, Option L18 (California)	191
8.1 L V8 Gas Engine, Utility, Option L18 (Export)	192
6.6 L V8 Diesel Engine, Pickup, Option LB7	193
6.6 L V8 Diesel Engine, Chassis Cab, Option LB7	194

PTO

Power Take Off (Chelsea) 6 Speed Manual Transmission – C/K 36.....	195
Power Take Off (Muncie) 6 Speed Manual Transmission – C/K 36	196
Power Take Off Manual Transmission – C/K 36	197
Power Take Off (Chelsea) 5 Speed Auto Transmission – C/K 36	198
Power Take Off (Muncie) 5 Speed Auto Transmission – C/K 36	199
Power Take Off Automatic Transmission – C/K 36	200

MID BUSSED ELECTRICAL CENTER (MBEC)

Mid Bussed Electrical Center (MBEC).....	201
MBEC, SEO and Trailer Connector	202
MBEC, Upfit and Cell Phone Connector	203

BODY BUILDERS INSTRUCTIONS

The Incomplete Vehicle Document (IVD) is supplied with each incomplete vehicle, and provides information that should be used by intermediate and final stage manufacturers in determining conformity to applicable Federal Motor Vehicle Safety Standards (FMVSS). The IVD also includes information which must be followed in order to ensure that Environmental Protection Agency (EPA) and California emissions certification requirements and NHTSA Fuel Regulations are met.

This Body Builders Book contains information that may be used in addition to the IVD for any manufacturer making alterations to a GM complete/incomplete vehicle. No alteration should be made to the incomplete vehicle which either directly or indirectly results in any component, assembly or system being in nonconformance with any applicable Federal Motor Vehicle Safety Standard or Emission Regulation. Intermediate and final stage manufacturers should be familiar with all Federal Motor Vehicle Safety Standards and Emission Regulations and aware of their specific responsibilities as manufacturers.

For further assistance contact Upfitter Integration at: 1 (800) 875-4742, or go to our Web site at “<http://www.gmupfitter.com>.”

Section 0 – General Instructions

Check for proper clearance between body members and chassis components which may in anyway affect the reliability and performance of the vehicle by developing abrasion and wear points from moving parts or degradation from extreme environment or thermal exposure or may increase interior noise.

Check headlamp aim and all vehicle illumination systems for proper operation when the vehicle has been completed. Re-aim head lamps when necessary. Check for proper operation of windshield washer, wipers and defroster system.

Extreme care must be taken when working on vehicles equipped with Engine Control Module (ECM), Powertrain Control Module (PCM), Transmission Control Module (TCM), Vehicle Control Module (VCM) or any electronic unit associated with an inflatable restraint system. (See Owner’s Manual).

If arc-welding is employed on the chassis, precautions must be taken to protect all vehicle components, especially brake and fuel lines, fuel tank assembly, electrical wiring and ECM/PCM/TCM or VCM. To avoid electronic component damage, disconnect battery (batteries); disconnect the negative cable first, followed by the positive. To reconnect cables; connect the positive first, then the negative.

When welding components to the frame assembly, remove the wax coating in the area of the weld in order to obtain secure welds. After completion of the weld, a compatible corrosion protection should be applied to the affected weld areas.

(Section 0 – continued on next page)

(Section 0 – continued from previous page)

All labels on the vehicle (any message applied to the vehicle or vehicle component that informs, instructs, or warns) must appear on the completed vehicle so the user can read them easily and without obstruction.

Those installing aftermarket systems should provide information as to where and how to obtain service and replacement parts.

When installing a Power Take-Off (PTO) with hydraulic lines, the following care should be exercised:

- Route and secure all hydraulic lines so that they are not in close proximity to any parts of the exhaust system. Keep all fittings and connections away from the exhaust system. Make sure connections and fittings cannot leak on the exhaust system.
- Exhaust system heat can damage and degrade hydraulic lines and components. Oils and hydraulic fluid coming in contact with a hot exhaust system could result in a fire.

Section 1 – Body

Accessory items, such as refrigerator, hot water heater, furnace, etc., which operate on liquid propane gas should be located and protected to prevent exposure to any flame.

GM has established automotive refinishing standards for itself as well as its aftermarket retailers. Each division requires the dealer or retailer to use only materials and methods that meet GM standard GM 4901M when repairing, replacing or refinishing vehicles.

Each year, all new paint systems will be tested and evaluated. New or improved products will also be tested. The paint systems that pass this annual testing process will be published in this booklet, and updated annually.

If GM 4901M booklets are needed, call 1-800-269-5100.

Body structures, interior and accessory arrangements must be designed into the vehicle to provide for proper load distribution on both axles and not to exceed any gross axle weight ratings. Lateral load equalization must also be maintained. The resultant Center of Gravity of the unladen vehicle must be within the limits tabulated in the FMVSS 105 section of the Incomplete Vehicle Document.

Body insulation provided by General Motors should not be removed. This includes any thermal or underbody heat shields. This insulation is provided to protect the vehicle body and occupants from excessive heat and/or provide noise attenuation. Any replacement material internal to the occupant compartment must be certified for FMVSS 302 Flammability of Interior Materials. Areas of specific concern, but not limited to are:

- Underbody exhaust, muffler and tail pipe shields and insulators.

(Section 1 – continued on next page)

(Section 1 – continued from previous page)

- Rear load floor interior insulation.
- Front floor interior insulation.
- Dash mat insulation.
- Engine cowl insulation – interior and exterior.
- Engine cover insulation.
- Hood Insulation

Conversions

A minimum of 10° departure angle should be maintained if frame and/or body is extended.

Selected trim components above the belt line have energy absorbing foam added behind the trim (headliners, A, B and C garnish moldings), to comply with MVSS 201. Any modification could affect compliance.

If body builder installs seating other than that supplied with vehicle, it is the body builder's responsibility to ensure that the seating and restraint systems comply with FMVSS requirements. The restraint systems supplied with the vehicle were designed to accommodate the seating reference points and seat travel of the original equipment seats only.

Air Conditioning

For additional information refer to **Engine - Section 6**.

NOTE: Air conditioning systems using R-134A refrigerant are equipped with metric fittings to prevent interchange with R-12 refrigerant components. Do not interchange R-134A components, refrigerant oil or service equipment with R-12 components, refrigerant oil or service equipment.

Rear Air Conditioning

This unit may be equipped with A/C quick-connect fittings (Option YF7) on the liquid tube (high pressure) and the suction (low pressure) return tube. These fittings are designed to accept matching Aeroquip connecting fittings attached to pre-charged lines. This allows a one time only connection to the O.E.M. charged A/C system without having to discharge, evacuate and recharge for the connection of a rear A/C system.

(Section 1 – continued on next page)

(Section 1 – continued from previous page)

A modification to the A/C system which causes the A/C plumbing lines to increase in length (such as the addition of a rear after-market evaporator and blower assembly) will necessitate the following changes:

- Lubrication – PAG refrigerant oil must be added to rear system to provide lubrication for compressor. Refer to Service Manual for specifications.
- Refrigerant – Add R-134A refrigerant to system based on sizing of new tubes, hoses and evaporator. Contact your A/C supplier for recommended charge.
- Label – Revise/modify GM charge label (located on top of front evaporator or A/C bottle) from factory recommended charge for a front system only to body builder's new recommended dual system per SAE J639. This is important for servicing the A/C system so that the technician knows the correct amount to add to the modified system.

Section 2 – Frame

Hole drilling, welding, modifications, or alterations to the frame assembly are the responsibility of persons performing these operations. These same individuals assume complete responsibility for frame assembly, reliability, performance after alterations and compliance to applicable FMVSS requirements.

The following procedures and specific precautionary instructions are recommended for proper installation of special bodies and/or equipment on GM frames. Failure to follow these recommendations could result in serious damage to the basic vehicle.

Flanges

Do not drill holes in frame flanges.

Holes

Holes to mount brackets, supports, and out-riggers must be drilled in the vertical side rail web with the following restrictions:

- Material between edge of hole and inside of upper or lower flange must not be less than 37 mm (1.50 in.) for HSLA (40,000 PSI yield).
- The minimum edge distance between any two (2) holes must be larger than twice the diameter of the larger hole.
- No holes should exceed 20 mm (0.75 in.) in diameter.
- All holes should be drilled in the frame using appropriate drilling practice and safety precautions.

(Section 2 – continued on next page)

(Section 2 – continued from previous page)

Welding

CAUTION: Fuel tank and fuel lines must be drained and all vapors purged to ensure non-combustible mixture before any welding, brazing or soldering.

When welding high-strength, low-alloy (HSLA 40,000 PSI yield strength) side rails or crossmembers and brackets (32,000 or 36,000 PSI yield strength), emphasis is placed upon weld application techniques to avoid stress risers that may adversely affect frame operating stresses.

When welding is performed anywhere on the vehicle, precautionary measures should be taken to prevent damage to electrical system wiring or components. Prior to any welding, parts or components which could be damaged by excessive temperatures must be removed or adequately shielded; the battery cables should be disconnected at the battery. Also prior to welding, the area to be welded and surrounding area must be cleaned of all frame protective coating. After welding, when parts are cool, carefully inspect wiring and electrical components for shorts or other damage which could draw excessive currents and possibly cause an electrical system short when the battery is reconnected. Apply protective coating to areas where coating was removed.

Alterations

If the wheelbase is modified the alterer must take responsibility for compliance with affected FMVSS and for warranty on items such as driveshafts, universal joints, center bearings and rear transmission tailshaft, transercase and transmission case fractures, output shaft bushings, bearings, brakes, fuel systems and any other related component failures. Additionally, the customer must be alerted in the modifier's owner's manual that parts for the reworked area are not available through the General Motors service parts system.

Shear Plate Attachments

Attachments of shear plates should be accomplished by using existing manufacturing holes already available in the frame side rails. Manufacturing holes, normally 25 mm in diameter, are consistently placed along the frame side member in the center of the web on each frame.

When additional holes are required for shear plate attachment, they should be no larger than 19 mm (0.75 in.) in diameter. Holes are to be drilled no closer than 63.5 mm (2.5 in.) apart. For holes drilled forward of the rear axle, centers are to be no closer than 63.5 mm (2.5 in.) from the top or bottom flanges and no closer than 89 mm (3.5 in.) from any suspension attachments. For frame holes drilled rearward of the rear axle, hole centers are to be no closer than 51 mm (2.0 in.) from the top or bottom flange and no closer than 89 mm (3.5 in.) from suspension attachments.

No additional holes or notching of either top or bottom frame flanges is allowed.

Section 3 – Front Suspension

Since there is a large variation in completed vehicle front weight due to differences in body weight and equipment, the front suspension alignment must be checked and reset if necessary after the vehicle is completed. Caster and camber should be set with reference to the “A” dimensions.

See Truck Service Manual for complete alignment procedure, specifications and measurement of the “A” dimension under “Diagnosis and Front Alignment” section.

C/K Models are designed such that camber and caster do not need adjustment unless severe road impact or accident deformation occurs. Toe should be reset after the vehicle is completed and while at normal operating load with trim height as specified (K-Model).

Section 4 – Rear Suspension

Clearance to body should be provided for the suspension, axle, driveshaft and tires under the following conditions: (1) Axle in full jounce against the metal-to-metal stop, (2) Axle at 4.5° roll with one side of axle in full jounce at the metal-to-metal stop and (3) Axle at design position. Allowance for the tire chain clearance shown on a maximum grown tire must allow for 42.2 mm (1.66 in.) clearance to the sides of the tire and 63.5 mm (2.5 in.) to the top of the tire. Be sure sufficient clearance is provided for suspension, axle and tire and wheel in full vertical travel (up and down).

NOTE: Notification to the consumer may be required in certain states if tire chains cannot be used.

Pipes, wiring, conduits and any other related components must not be placed where they cross the path of motion of the rear axle, driveshaft, axle brake pipes, hoses, spring or tires. Such crossing could result in rupture, wear-through, or separation due to normal axle motion.

See chassis data information for additional clearances and for assistance in calculating trim heights.

Section 5 – Brakes

See Truck Service Manual for brake specifications.

Due to the critical nature of brake systems, anyone making modifications or alterations must assume complete responsibility for system reliability, performance and certification to FMVSS 105 or FMVSS 121.

(Section 5 – continued on next page)

(Section 5 – continued from previous page)

It is mandatory that no change be made to the brake main cylinder location, brake pedal push rod length or pedal position. Ensure that the hydraulic brake system is free of air and hydraulic leaks. Bleed brakes if required, following procedures as outlined in truck chassis service manual. Ensure that the vacuum booster system or hydraulic brake booster system is functional and free of leaks.

Check master cylinder fluid level and fill as necessary. (Refer to Owner's Manual).

Check power steering fluid level for models equipped with hydroboost brake. (Refer to Owner's Manual).

Added floor covering or carpeting must not restrict service or parking brake pedal travel from released position to full pedal travel.

No body part or chassis-mounted component may be located within 2.0 in. of brake hose routing in all wheel and axle positions. All exhaust system components must also have a minimum of 2.0 in. clearance to brake hoses in closest positions. (Be sure to account for brake hose travel with suspension.)

Body builder is to verify that the brake warning switch is operative. The brake warning switch on models equipped with vacuum-hydraulic brakes is located on the master cylinder. This includes both the brake system fluid level and parking brake actuator switch.

Section 6 – Engine

For additional information refer to ***Body - Section 1.***

Air conditioning and auxiliary belt-driven equipment installation recommendations:

No alterations or additions to the accessory drive belt system will be warranted on serpentine belt systems.

The serpentine belt type of drive is designed as a total system, incorporating a single poly-V belt and an automatic tensioner. In this type of system, degrees of pulley wrap, belt tension, and pulley alignment are very critical factors. Modification is not recommended.

In some single belt serpentine systems, belt tension is determined by the automatic tensioner and its position relative to the belt. No adjustment required.

Due to the critical nature of the accelerator system, anyone making modifications or alterations assumes complete responsibility for system reliability, performance and compliance to FMVSS 124. Caution must be exercised so that the accelerator cable is properly routed. Specifications are as follows:

- Route cable to maximize all bend radii. In no case should bend radii be less than 3 in. (76 mm).

(Section 6 – continued on next page)

(Section 6 – continued from previous page)

- Minimum distance from exhaust manifold to be 6.0 in. (150 mm), unless a heat shield is provided.
- Do not use accelerator cable or clips to route wires, harnesses or other cables. Cable sheath must be clipped so as not to pinch inner cable. Cable must not be loose in clip allowing sheath to move when accelerator pedal is applied and released.
- Cable must not be subjected to kinking or routing across any sharp edges.
- Cable routing must be perpendicular to the surface of the front-of-dash at the dash fitting. No objects or routings should force cable to have a bend at the dash fitting. Flexible components (hoses, wires, conduits, etc.) must not be routed within 2.0 in. (50 mm) of moving parts or accelerator linkage unless routing is positively controlled.
- Caution must be taken so that the accelerator pedal remains properly located. Guidelines for accelerator pedal locations are as follows:
 - 1) Ensure that the accelerator can freely operate from idle to wide-open throttle position and return. Make sure that the pedal will not hang up on any nearby items such as carpets, floor, screws, wiring harnesses, etc. Engine cover should have at least one inch (25 mm) clearance to side of accelerator pedal with the carpet mat installed.
 - 2) Accelerator to brake pedal relationship has been designed to provide minimum driver movement and should not be altered in any way.

Gasoline engine induction and/or ignition system is certified in compliance with the Federal Vehicle Emission Standards. Any alterations to the systems or components could void compliance and render the vehicle illegal. System includes:

- Fuel system – throttle body injector (TBI) or central port injector (CPI) and associated tubes, hoses and pipes, air cleaner, outside air hose and spacer heat stove and heat stove pipe, fuel pump and inlet manifold, fuel vapor canister.
- Exhaust system.
- Ignition system distributor and initial spark timing setting, spark plugs, spark plug wires.
- Crankcase ventilation system.

Diesel engine induction and injector pump system is certified to be in compliance with the Federal Vehicle Emission Standards and/or Noise Standards. Any alterations to the system or components could void compliance and render the vehicle illegal. System includes:

- Fuel system – Injection pump, injector lines and injectors, fuel return hoses and pipes, air cleaner, outside air hose, fuel pump, fuel filter, fuel heater assembly and intake manifold.
- Exhaust system.

(Section 6 – continued on next page)

(Section 6 – continued from previous page)

- Crankcase pressure regulation system.
- Charge air cooler system.
- External engine components, such as air cleaner, crankcase pressure regulator valve, alternator, injection pipes, fuel return hoses from injectors, exhaust manifolds, oil fill pipe, etc., must be provided with sufficient clearance for engine roll and torque.
- When a vehicle is equipped with a electronic fuel injection (EFI) engine, it has an engine control module ECM/PCM/TCM or VCM. This ECM/PCM/TCM or VCM must be maintained at a temperature below 185°F at all times. This is most essential if the vehicle is put through a paint baking process. The ECM/PCM/TCM or VCM will become inoperative if its temperature exceeds 185°F. Therefore, it is recommended that temporary insulation be placed around the ECM/PCM/TCM or VCM during the time the vehicle is in a paint oven or undergoing another high temperature process.

Section 7 – Transmission

Light duty models equipped with manual transmission have a clutch-operated start safety switch. Starter should operate whenever the ignition is turned to start and the clutch is fully depressed. Readjust if necessary as outlined in the Truck Service Manual.

Models equipped with automatic transmissions have a steering column mounted neutral/park start safety mechanical lockout feature, which interfaces with the steering column ignition switch. Starter should operate only when gearshift lever is in neutral or park position. Readjust the shift linkage if necessary as outlined in the Truck Service Manual.

Power Take-Off (PTO) systems refer to **General - Section 0**.

- The NV4500 manual 5-speed heavy-duty overdrive transmission (RPO MW3) requires the use of special synthetic lubricant to reduce transmission internal operating temperatures. The lubricant is installed in all NV4500 transmissions at the factory.
- In instances where it is necessary to drain and refill or add fluid to the transmission, such as when installing PTO, DO NOT substitute any other lubricant. Installation of other lubricants may result in internal transmission damage.
- Castrol Syntroq GL4 is the only synthetic lubricant currently approved for use in the NV4500. This product can be secured through your local GM dealer under GM part number 12346190 per quart.
- Transmission lubricant capacity is 8.5 pints.

Models equipped with manual transmission use a hydraulic clutch actuator. Check fluid level as outlined in the vehicle owner's manual.

(Section 7 – continued on next page)

2005 & BEYOND C/K FULL SIZE TRUCKS (PICKUPS, UTILITIES AND CHASSIS-CABS)

(Section 7 – continued from previous page)

It is mandatory that no change be made to the clutch master cylinder location, clutch master or slave cylinder push rod length, or pedal position.

POWERTRAIN SPECIFICATIONS AND LINE-UP CHARTS

SPECIFICATIONS – AUTOMATIC TRANSMISSIONS

	4-SPEED	5-SPEED
RPO	MT1	M74
MAKE	4L80E	ALLISON
CASE MATERIAL	ALUMINUM	ALUMINUM
TORQUE RATING (LB.-FT.)	440	450
RATIO (:1)		
1st Gear	2.48	3.10
2nd Gear	1.48	1.81
3rd Gear	1.00	1.41
4th Gear	0.75	1.00
5th Gear	N/A	0.71
Reverse	2.08	4.49
OUTPUT SHAFT SPLINE # OF TEETH	32	34
PITCH DIAMETER	33.87 mm	43.18 mm
TORQUE CONVERTER CLUTCH	YES	YES
SIZE	310 mm	310 mm
“K” FACTOR	6.0L = 117	8.1L = 114 6.6L = 107
STALL TORQUE RATIO	6.0L = 2.3	8.1L = 2.05 6.6L = 2.0
PTO OPENING	NONE	YES

Two automatic transmissions are used in 25HD/35/36 C/K series trucks:

MT1/4L80-E: Used on all 9,200 LB GVWR

M74/ALLISON: Used on all 11,400 LB and 12,000 LB GVWR

AUTOMATIC TRANSMISSION/ENGINE AVAILABILITY MATRIX

ENGINE / TRANSMISSION	MT1	M74
6.0L GEN III	BASE	N/A
8.1L	N/A	BASE
6.6L DIESEL	N/A	BASE

(Section 7 – continued on next page)

(Section 7 – continued from previous page)

SPECIFICATIONS – MANUAL TRANSMISSIONS

	5-SPEED	6-SPEED
RPO	MW3	ML6
CASE MATERIAL	CAST IRON	ALUMINUM
TORQUE RATING (LB.-FT.)	410	520
RATIO (:1)		
1st Gear	5.61	5.79
2nd Gear	3.04	3.30
3rd Gear	1.67	2.10
4th Gear	1.00	1.30
5th Gear	0.75	1.00
6th Gear	N/A	0.72
Reverse (Synchronized)	5.04	5.23
SHAFTS CENTER DISTANCE	109 mm	105 mm
CLUTCH PLATE DIAMETER	12" (302 mm)	12" (303 mm)
PTO OPENING	YES – Left or Right	YES – Left or Right

Two manual transmissions are available in 25HD/35/36 C/K series trucks:

MW3: Available for 9,200 LB GVWR. See specific powertrain charts for details.

ML6: Available for 11,400 LB and 12,000 LB GVWR. See specific powertrain charts for details.

Section 8 – Fuel and Exhaust

Fuel Systems

The fuel evaporative emission control equipment is certified to be in compliance with the Federal and California Vehicle Emission Standards. The fuel tank is molded from multilayer plastic and should not be repaired or altered. Metal fuel lines have a surface coating to reduce corrosion on inside and outside surfaces to comply with useful life requirements. All fuel hoses, including plastic lines, are made of a low permeation multi-layer material to comply with enhanced evaporative emission requirements. Any alterations to systems or components including materials, hose lengths and their location, except as described in the fuel fill system modifications section, could void compliance. The system includes:

- Fuel tank, fuel level sender, fuel fill and vent hoses and pipes, emission canisters, fuel feed, fuel return and vapor lines, purge control solenoids, fuel fill cap, canister vent solenoid.

(Section 8 – continued on next page)

(Section 8 – continued from previous page)

For these reasons, **NO ALTERATION OF THE FUEL SYSTEM IS RECOMMENDED.**

Fuel Fill

It is recommended that when mounting the fuel filler pipe assembly and vent hose that a minimum of 3.0 in. clearance be provided to any body component to prevent contact between hoses and/or mating parts and that retention be provided to ensure routing and prevent failure due to wear and fatigue. Both the fill and vent hoses must be routed (and supported, if needed) such that there are no sags or kinks. As viewed from the filler neck, pipes and hoses must have a downward slope toward the tank. There should be a minimum of 4° of downward slope in the fill and vent pipe at any location. No fuel traps are allowed. Alterations of fuel line routings could affect the ability of the completed vehicle and are, therefore, not desirable. The complete fuel system must comply with FMVSS 301. If additional new hose is required when installing fuel tank filler neck, this hose must be suitable for use with unleaded fuels or diesel fuel respectively and must allow the vehicle to meet enhanced evaporative emissions requirements.

Fuel Lines

Fuel line routing precautions:

- 5 in. minimum clearance to exhaust system is required or a metal shield must be provided.
- Fuel lines should be clipped to chassis to prevent chafing. Metal clips must have rubber or plastic liners.
- Use corrosion resistant steel tubing with short sections of approved hose to connect components. Hose-to-tube connections should be clamped for diesel systems. Steel tube ends should be beaded for hose retention. Fuel supply is pressurized by an in-tank pump for MPFI and SCPI systems. Coupled hose or nylon quick-connects must be used. Clamped hose is not acceptable for MPFI and SCPI systems.

All engines require a fuel return system which returns excess fuel from the injection pump and injector nozzles back to fuel tanks. Care should be taken that these lines are not blocked nor their hoses pinched. The engine may run poorly or stall if these lines are restricted or blocked.

All gasoline engine vehicles are equipped with fuel evaporative emission control equipment which is certified to be in compliance with the Federal or applicable California Vehicle Emission Standards. Alterations to fuel tank and metering unit, lines, canister or canisters, canister filters, canister purge control valves, relay switches, tank auxiliary vent valve, engine speed controller, or other devices/systems are therefore not allowable since vehicle adherence to C.A.R.B. and Federal regulations may be affected.

Diesel powered vehicles incorporate water drain provisions in the fuel system. These valves are only to be opened when siphoning water and contaminants from the fuel system.

(Section 8 – continued on next page)

(Section 8 – continued from previous page)

Body attachment brackets and u-bolts must be located such that there is adequate clearance to all fuel system components, such as the fuel lines and the fuel level sending unit, under all operating conditions.

Fuel Tank

For vehicles with full frames, the tank must have a minimum clearance of 2 in. top, front, rear and sides to body and other supports.

Tank may be pressurized to 1.25 PSI maximum to check for final line leakage or for forcing fuel through the system. Pressures greater than this amount may be detrimental and affect tank durability.

The use of auxiliary fuel tanks is not recommended. If an auxiliary fuel tank is added, the alterer must take responsibility for compliance with affected motor vehicle safety standards. Also, if an auxiliary fuel tank is added to a gasoline-powered vehicle, the fuel must be drawn through a pipe at the top of the tank (balance line between tanks is not permitted).

Gasoline fueled vehicles are equipped with a fuel pump return line. If an auxiliary tank is added, the tank selector valve must include a return port which returns fuel to the tank from which the fuel is being drawn.

In gasoline engines the fuel pump is located in the fuel tank. The battery must be disconnected before starting any work on the fuel system.

Gaseous Fuel Conversions

All truck gasoline engines may be converted to use liquified petroleum gas (LPG) or natural gas (NG); GM only approves the conversion of vehicles with option KL5. However, some conversions may cause harmful effects to the engine. Such fuel systems may require assurances from alternate fuel system manufacturers and/or installers that the equipment will not cause damage to the engine or the exhaust system.

In the use of dual fuel systems, the vehicle operator should strictly adhere to the manufacturer's procedures for switching from gasoline to gaseous fuel operation. Improper switching procedures may result in overheating and damage to the exhaust system and the vehicle. The gaseous fuel tank should not be mounted in an enclosed area of the vehicle, such as the passenger compartment, truck, etc., and the system should be vented to the outside of the vehicle. In addition, vehicles converted to gaseous fuels should not be stored in enclosed places such as garages. Further, General Motors cautions purchasers that the design, location and installation of any type of fuel storage system involves significant technical and engineering considerations and that these statements on gaseous fuel conversions should not be interpreted to be an approval by General Motors of any modification to the original equipment fuel system. Conversions to gaseous fuel should be made in conformance with applicable Federal and State regulations. Removal of emission-control components or the addition of gaseous fuel systems, which could damage or reduce the longevity of those components could also cause the mechanical and emission performance warranty to be voided.

(Section 8 – continued on next page)

(Section 8 – continued from previous page)

Exhaust System

Particular care should be taken to prevent the possibility of exhaust fumes and carbon monoxide exposure to vehicle occupants in units completed by body builders. Holes and openings through the floor and all other parts of the body must be permanently and adequately sealed by the body builder to avoid exhaust intrusion into any occupant area. If it is necessary to change the exhaust outlet location, the exhaust discharge must be unobstructed and directed away from occupant areas. Alteration of the exhaust outlet or its position may increase exhaust noise and render the vehicle illegal in those areas with pass-by noise regulations. All vehicles >10,000 lbs. GVWR come under Federal noise regulations, vehicles ≤10,000 lbs. GVWR are regulated by various state and local regulations of the Environmental Protection Agency; see those regulations for rules, test procedure and noise levels permitted.

Tail pipe outlet location must be tested statically and with the vehicle in motion to ensure that exhaust gases do not penetrate side or rear windows or under body seams and holes. Auxiliary power plants should also be tested under the same conditions. Tail pipe exit ahead of rear wheels is not recommended.

Check for leaks in exhaust systems and repair as required.

Exhaust temperatures can exceed 1600°F under extreme operating conditions, with pipe surface temperatures slightly less than this. Extreme care must be used when placing body components in the proximity of the exhaust system so as not to exceed the rated temperature limits of the components. Due to variants in underbody configurations of the vehicles, we are not in a position to make recommendations on how to insulate or design components in the proximity of the exhaust system.

Each manufacturer must make temperature checks of critical areas of his vehicle and adjust his design accordingly, or provide shielding to ensure safe operation of his body components.

The same can be said for the engine compartment. Obviously there will be additional heat radiated from the engine. How much is retained in the area will depend on how well this area is ventilated in your individual designs. Here again, temperature checks of interior areas surrounding the engine should be made to determine if your insulation is adequate. This is the same engineering practice we have followed on our complete vehicles incorporating these exhaust systems.

Exhaust system materials are selected and tested to withstand the operating environment of the vehicle. **Do not modify the exhaust system in any way.** The tail pipes are made of 409 stainless steel.

Heat shields are mounted to the underbody and/or exhaust system components (catalytic converter and muffler). Shields for the propshaft hanger bearings are also provided in some vehicles.

Section 9 – Steering

Check power steering fluid level and system operations. (Refer to Owner's Manual).

Steering wheel and horn pad must not be altered or replaced.

The steering column mast jacket must not be altered.

Section 10 – Tires

Check wheel lug nuts for proper torque; specifications are provided in the Owner's Manual.

Substitution of tires of greater capacity than those offered as original equipment by vehicle manufacturer is not approved for use on original equipment wheels. Any usage of higher capacity tires must be accompanied by higher capacity wheels. However, the wheel offset (the distance from centerline of rim to wheel mounting face) must be the same as the replaced original equipment wheel to ensure proper wheel bearing loading and clearance of tires to body and chassis components. Increasing tire and wheel capacity does not necessarily increase vehicle GVW ratings.

Any substitution of tires may affect Speedometer/Odometer accuracy.

It is recommended that tire chain clearance guideline J683, from the Society of Automotive Engineers, be adhered to in designing rear wheelhouse clearance.

Check tires and inflate to recommended tire pressure according to the tire pressure information provided in Owner's Manual and tire inflation label provided with vehicle.

Section 12 – Electrical Battery and Battery Cables

The vehicle battery should be located and positioned to make use of the existing battery cables. If the battery requires relocation and longer cables are required, a proportionately larger gauge wire must be used. If, in relocating the battery the negative ground cable is attached to the frame rail, a cable of similar gauge must be provided between the frame rail and the engine. This is required due to the heavy electrical loads imposed by the starting circuit. To ensure proper operation of the battery cables the following chart on length, gauge and materials must be strictly adhered to:

(Section 12 – continued on next page)

(Section 8 – continued from previous page)

Combined length of positive and negative	
Cable Gauge	Cable in Inches (Copper)
4	66
2	107
0	170

The All New C/K is equipped with a Remote Positive (+) Jump Starting terminal which is located behind a red plastic cover near the engine accessory drive bracket. This terminal is intended for jump starting only and should NOT be used by upfitters to obtain battery power. Three fused studs, however, are available on the Underhood Electrical Center and, if available, may be used by upfitters to obtain battery power. If the battery is remotely mounted (other than in the engine compartment), the 'sense' circuit in the generator regulator shall be used. The sense circuit consists of a 7.76 OHM 1/4 watt resistor connected in series between the 'S' terminal of the generator and the B+ terminal of the battery.

Auxiliary Battery (Gasoline Engines Only)

If an auxiliary battery is to be retro-fitted, the electrical schematic for option TP2 is recommended as a guide. This will result in the auxiliary battery being connected to the vehicle load and charging circuit when the ignition switch is 'on' (fuse block terminal "Acc. Ign. Fused"). When the ignition switch is turned off, the interlocking relay is disengaged and the auxiliary battery is disconnected from the vehicle circuit.

Modifications/add-on wiring must be carefully reviewed to ensure compatibility with the base vehicle wiring by reviewing system schematics, wire routing paths, harness connections, etc. Due to the wide range of modifications that may be required for vocational needs, it is not feasible for the O.E.M. to take into account all potential revisions. For this reason, any person modifying existing vehicle wiring must assume responsibility that the revisions have not degraded the electrical system performance. Any add-on wiring must be properly fused and routed to prevent cut, pinch, and chafe problems, as well as avoid exposure to excessive heat. Care must be exercised that existing vehicle interfaces do not have their current load capabilities exceeded and the respective control devices are not overloaded. Added wire size should be at least as large as the wire to which it is attaching in order for fuse protection to be maintained.

A Packard Electric wiring repair kit is available through Kent-Moore (GM P/N 12085264, Kent-Moore P/N J38125-4). This kit contains instructions, tools and components for making repairs to wiring harness components. This kit would also greatly assist in accomplishing necessary add-on wiring, such as body marker lamps, so that system reliability/durability is maintained.

Electrical wiring components can be obtained through your authorized GM dealer. Many Packard Electric components are also available through Pioneer Standard Company (1-800-PACKARD). Pioneer may also be able to assist in making necessary wiring additions by providing custom wiring stubs or jumpers to your specifications.

Section 13 – Cooling

To provide satisfactory engine cooling, the following conditions must be met:

1. Do not locate any large objects in front of the radiator core or grille, such as batteries, spare tires, lights/sirens, etc. They restrict air flow into the radiator core and influence fan blade stress.
2. Grille opening, size configuration and the external baffles provided should not be altered in any manner. Any reduction in cooling ability may adversely affect engine/transmission performance.
3. Fan clutches not conforming to the original equipment specifications may not operate correctly and may stay “on” continuously, never come on, or cycle on and off excessively. This will result in a reduction of fuel economy, engine overheat at times, and annoying cycling respectively.
4. Heavy duty cooling equipment is required when snow plows, winches, etc., are installed.
5. If a heater unit is not installed in the vehicle or a heater shut-off valve is required, a line connecting the heater connection on the engine to the heater connection on the radiator must be installed. When a shut-off valve is required in the heating system, it must be teed into the system in such a manner as to maintain continuous flow between engine heater connection – radiator heater connection at all times.

Do not install any internal flow restrictors.

- Heater hose: 3-way or 4-way valves must be used to provide constant water flow through the intake manifold pad area used to mount the TBI unit (L35 only).

NOTE: TBI unit does not have internal coolant passages.

2005 & BEYOND C/K FULL SIZE TRUCKS (PICKUPS, UTILITIES AND CHASSIS-CABS)

Model Symbol Chart

Series	2-Door Pickup Fleetside/Wideside	2-Door Pickup Sportside	2-Door Chassis-Cab	4-Door Ext'd Cab Wideside/Fleetside	4-Door Ext'd Cab Sportside	4-Door Extended Chassis-Cab	4-Door Crew Cab Fleetside/Wideside	4-Door Crew Cab Chassis-Cab	4-Door Utility	Suburban	4-Door Ultimate Utility	GVWR (Lbs)	Nominal Ton Rating	Wheel Base (Inches)	Cab To Axle (Inches)
C/K 155							43 + E63 (5' 8.5" Box)					C 6800 K 7000	1/2	143.5	32.5
C/K 157	03 + E63 (6.5' Box)	03 + E62 (6.5' Box)										C/K 6100	1/2	119.0	42
				53 + E63 (6.5' Box)	53 + E62 (6.5' Box)					06		C 6200 K 6400	1/2	143.5	42
C/K 159												C 6300/6600 K 6800/6900	1/2	116.0	
	03 + E63 (8' Box)											C 6400 K 6100	1/2	133.0	56
				53 + E63 (8' Box)								C/K 6400	1/2	157.5	56
										06		C 6800 K 7200	1/2	130.0	
											36	C/K 7000	1/2	130.0	
C/K 257							43 + E63 (6.5' Box)					C/K 8600	3/4	153	42
C/K 257HD				53 + E63 (6.5' Box)								C/K 9200	3/4	143.5	42
							43 + E63 (6.5' Box)					C/K 9200	3/4	153.0	42
C/K 259HD	03 + E63 (8' Box)		03 + ZW9									C/K 9200	3/4	133.0	56
				53 + E63 (8' Box)								C/K 9200	3/4	157.5	56
							43 + E63 (8' Box)	43 + ZW9				C/K 9200	3/4	167.0	56

2005 & BEYOND C/K FULL SIZE TRUCKS (PICKUPS, UTILITIES AND CHASSIS-CABS)

Model Symbol Chart (continued)

Series	2-Door Pickup Fleetside/Wideside	2-Door Pickup Sportside	2-Door Chassis-Cab	4-Door Ext'd Cab Wideside/Fleetside	4-Door Ext'd Cab Sportside	4-Door Extended Chassis-Cab	4-Door Crew Cab Fleetside/Wideside	4-Door Crew Cab Chassis-Cab	4-Door Utility	Suburban	4-Door Ultimate Utility	GVWR (Lbs)	Nominal Ton Rating	Wheel Base (Inches)	Cab To Axle (Inches)
C/K 259										06		C/K 8600	3/4	130.0	
											36	K 8600	3/4	130.0	
K359	03 + E63 (8' Box)		03 + ZW9									K 9900	1	133.0	56
				53 + E63 (8' Box)								K 9900	1	157.5	56
							43 + E63 (8' Box)	43 + ZW9				K 9900	1	167.5	56
	03 + E63 (8' Box)		03 + ZW9									K 11400	1	133.0	56
C/K 359				53 + E63 (8' Box)								C/K 11400	1	157.5	56
							43 + E63 (8' Box)	43 + ZW9				C/K 11400	1	167.5	56
C/K 360			03 + ZW9									C 11400 K 12000	1	137.0	60
						53 + ZW9						C 11400 K 12000	1	161.5	60
C/K 364			03 + ZW9									C 11400 K 12000	1	161.5	84

C/K (15/25)703 General Arrangement

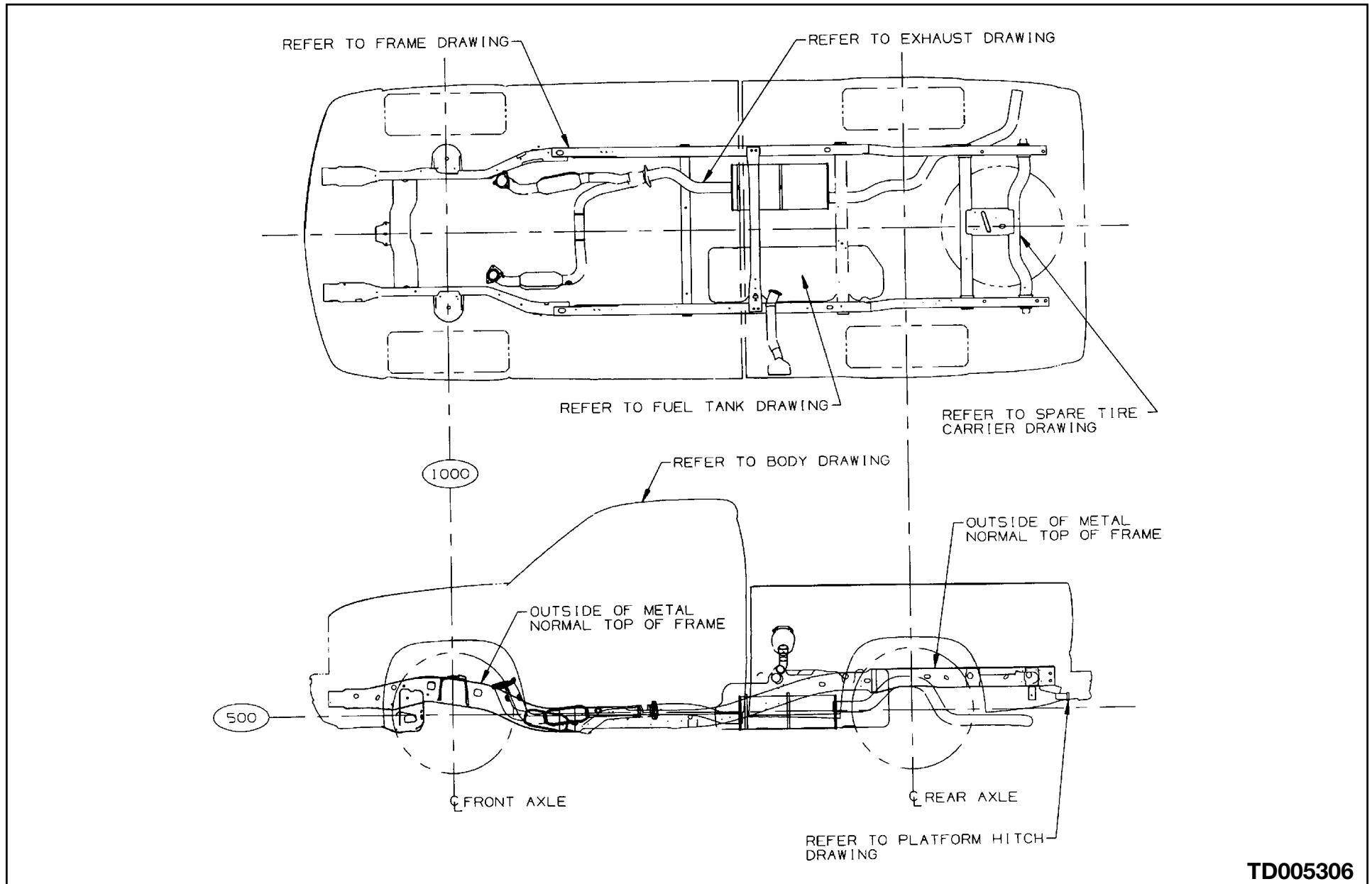

TD005306

C/K 15706 General Arrangement

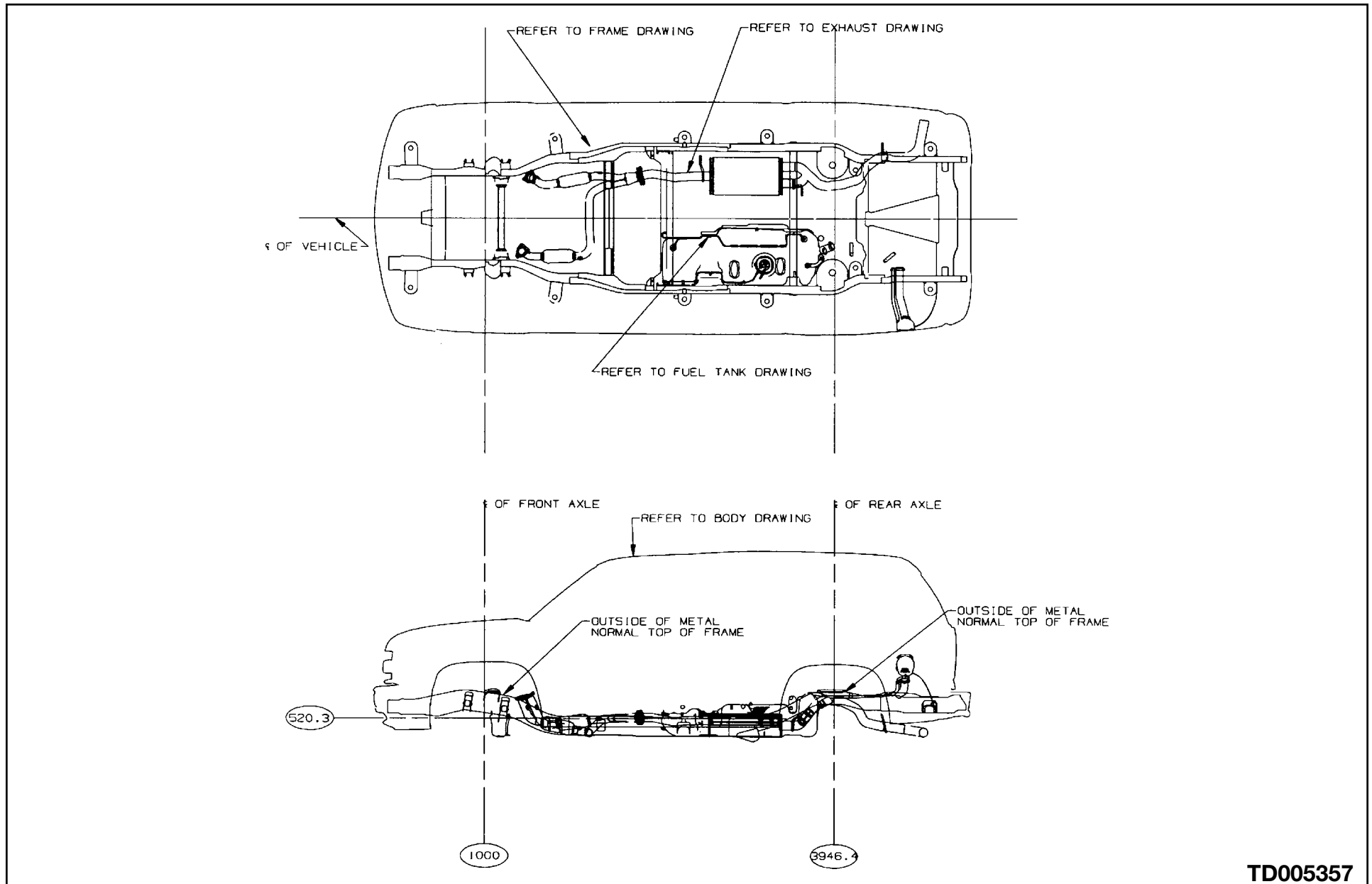

TD005357

C/K (15/25)906 General Arrangement

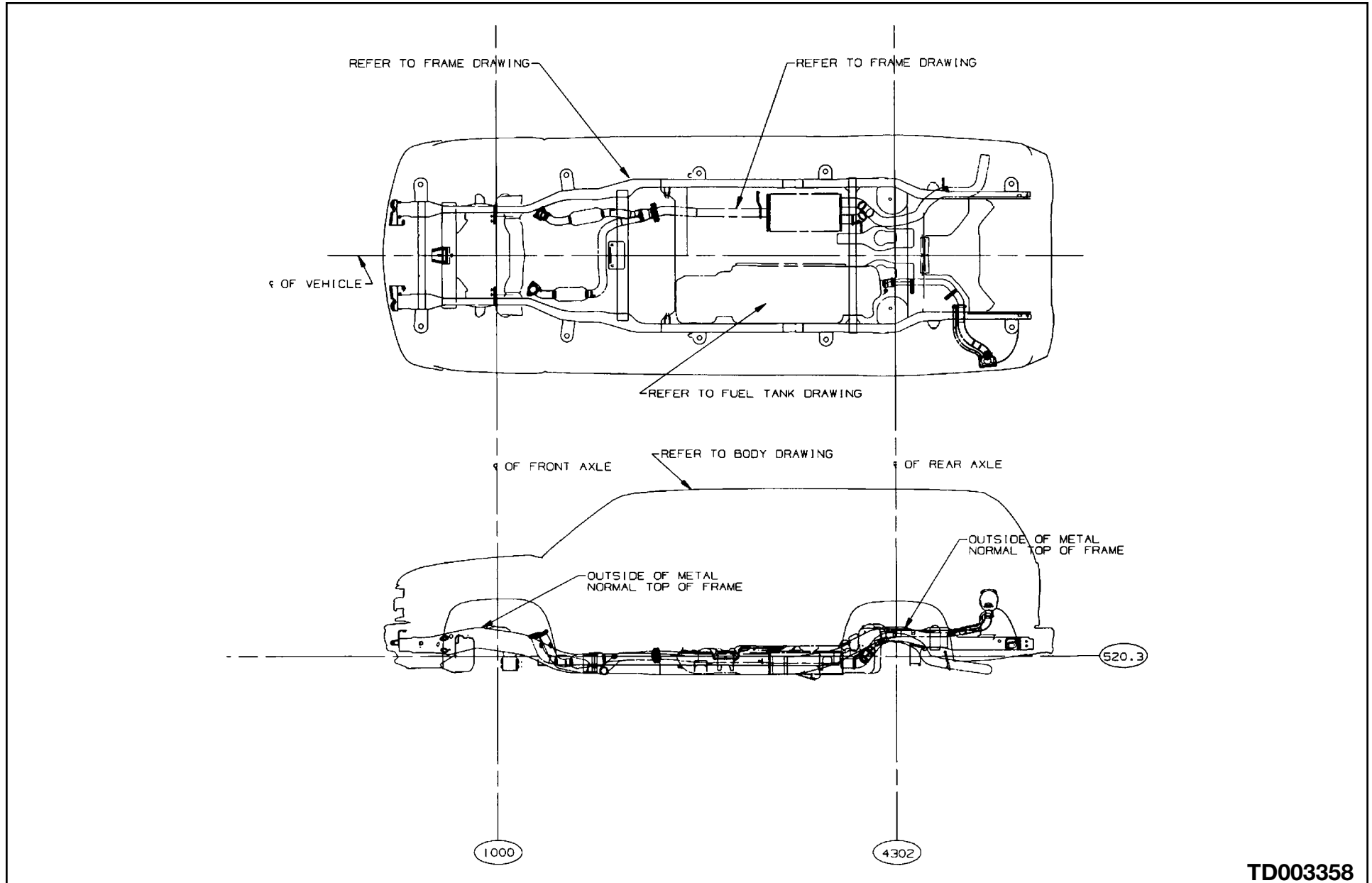

TD003358

C/K (15/25)936 General Arrangement

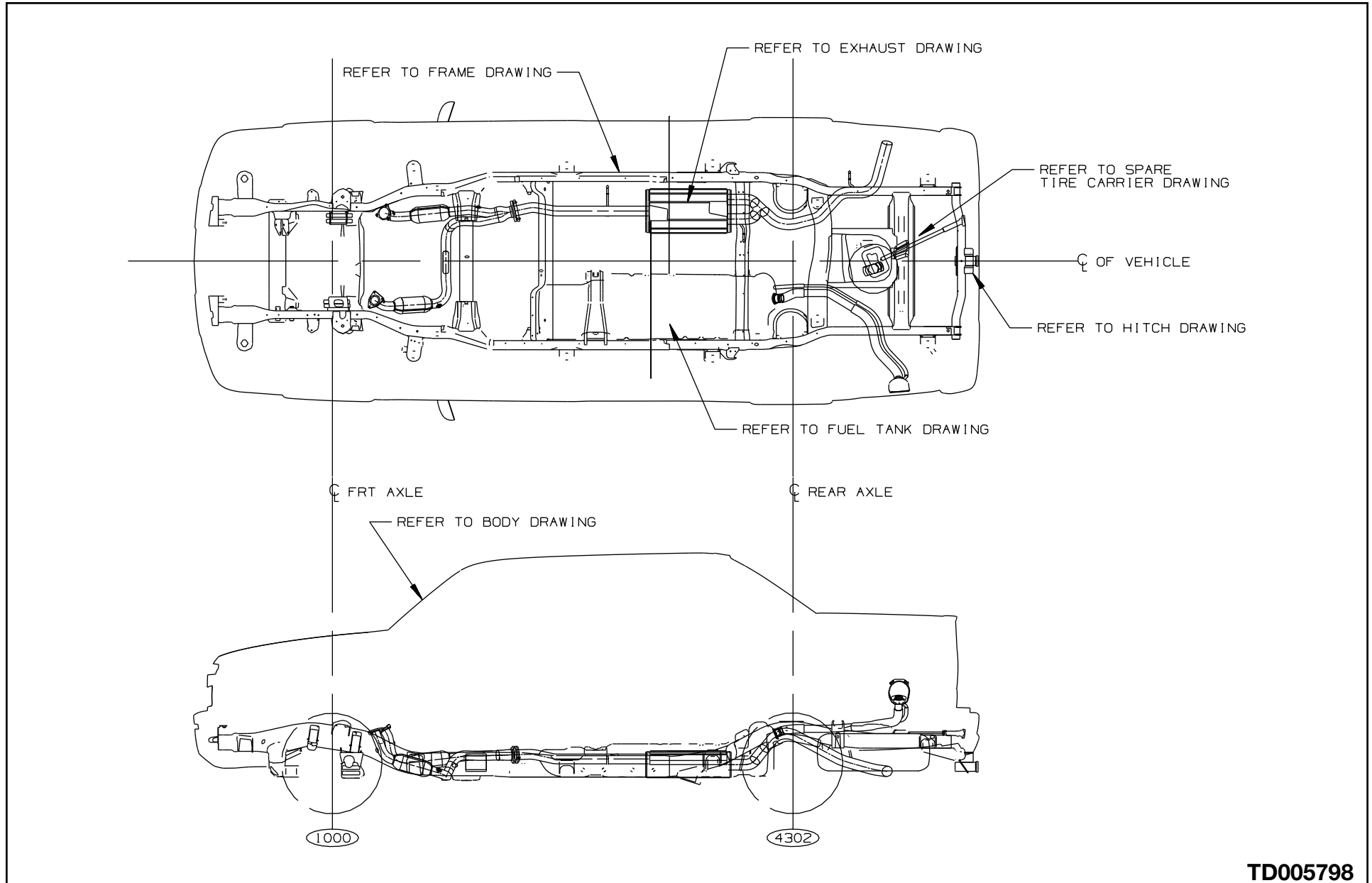

TD005798

2005 & BEYOND C/K FULL SIZE TRUCKS (PICKUPS, UTILITIES AND CHASSIS-CABS)

C/K 15703 Regular Cab with Short Box (Option E63)

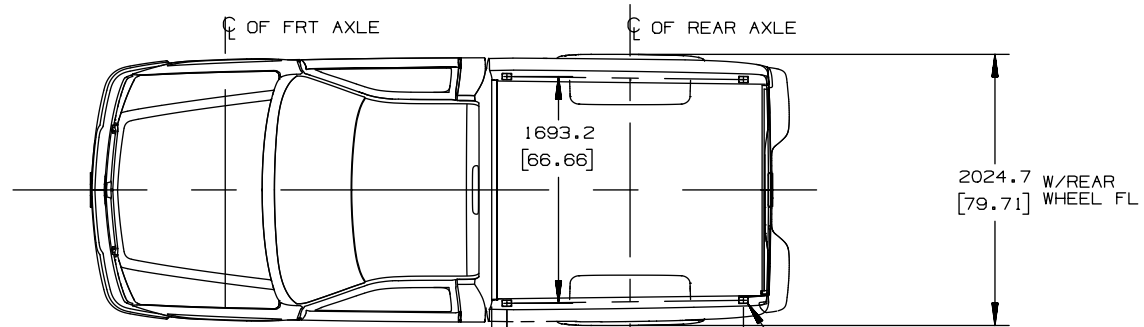

1000

113.4 [4.46] 1766.3 [69.54]

ALL STAKE POCKET OPENINGS ARE APPROX 46.9 X 69.9 4 PLACES (1.85) X (2.75)

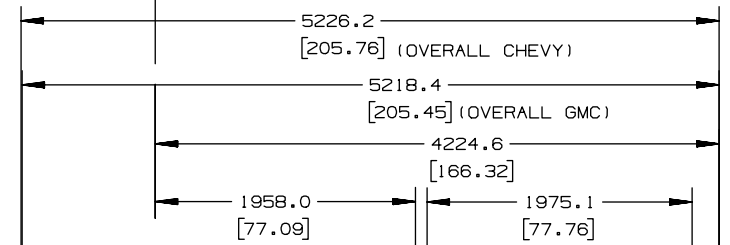

SEE FRT END SHEET METAL DRAWING (CHEVY SHOWN)

ALL DIMENSIONS SHOWN FOR CHEVY BASED MODEL UNLESS OTHERWISE NOTED

500

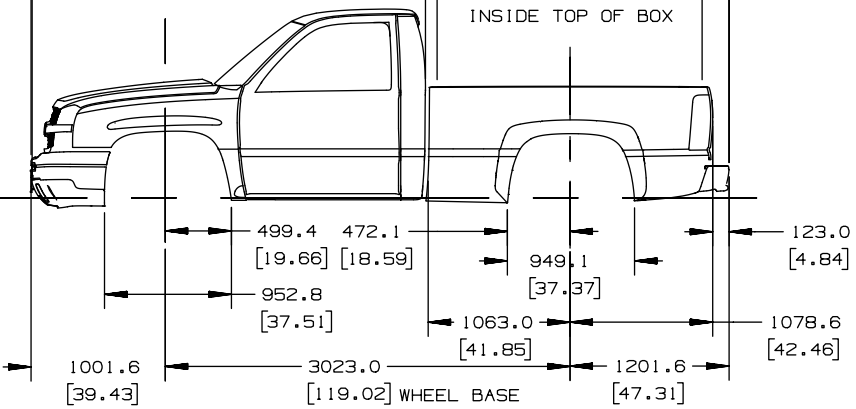

GMT 800 MCE 2003 C/K 15703 REG CAB W/SHORT BOX

[] = INCHES

2005 & BEYOND C/K FULL SIZE TRUCKS (PICKUPS, UTILITIES AND CHASSIS-CABS)

C/K (15/25HD/35)903 Regular Cab with Long Box (Option E63)

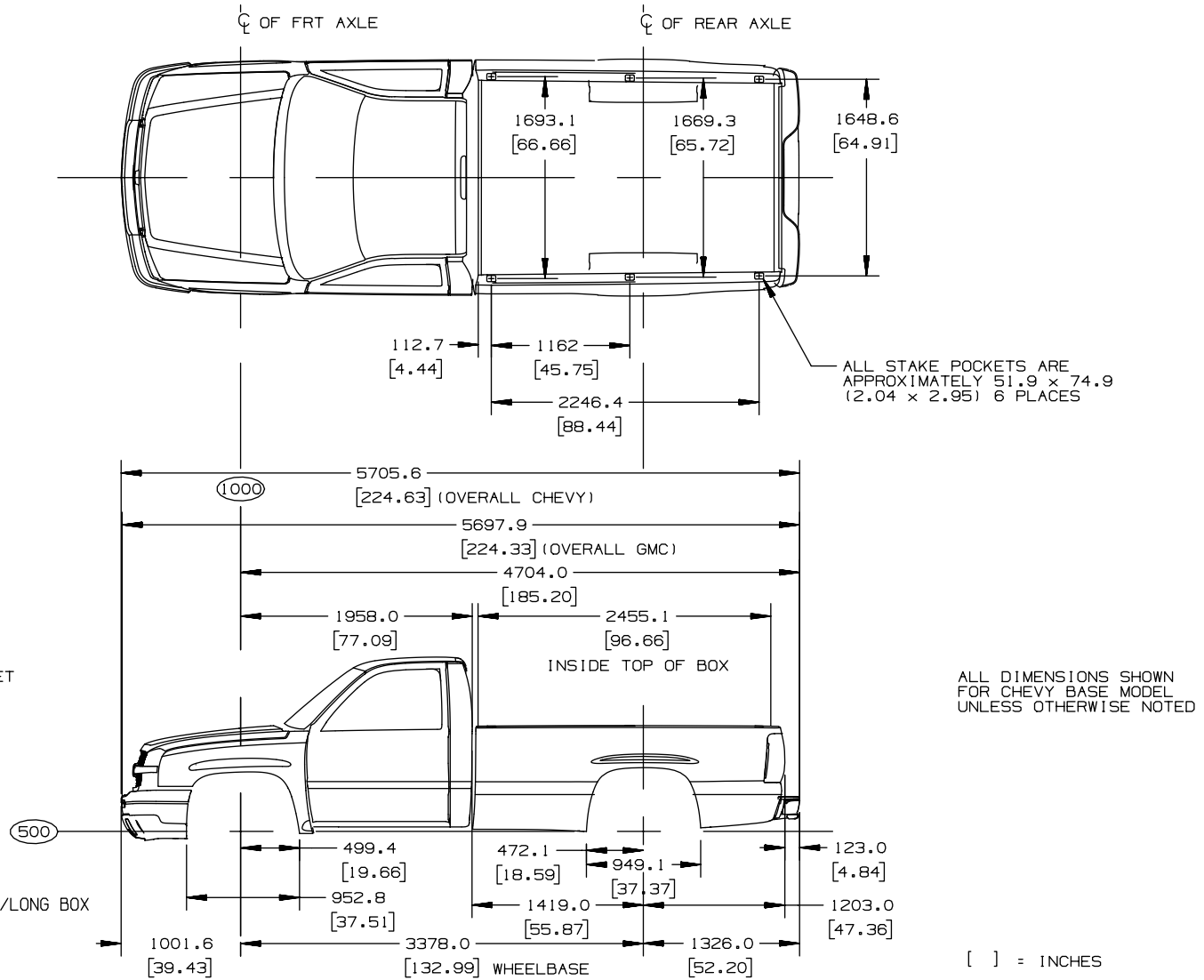

TD006013

2005 & BEYOND C/K FULL SIZE TRUCKS (PICKUPS, UTILITIES AND CHASSIS-CABS)

C/K 15703 Regular Cab, Sportside (Option E62)

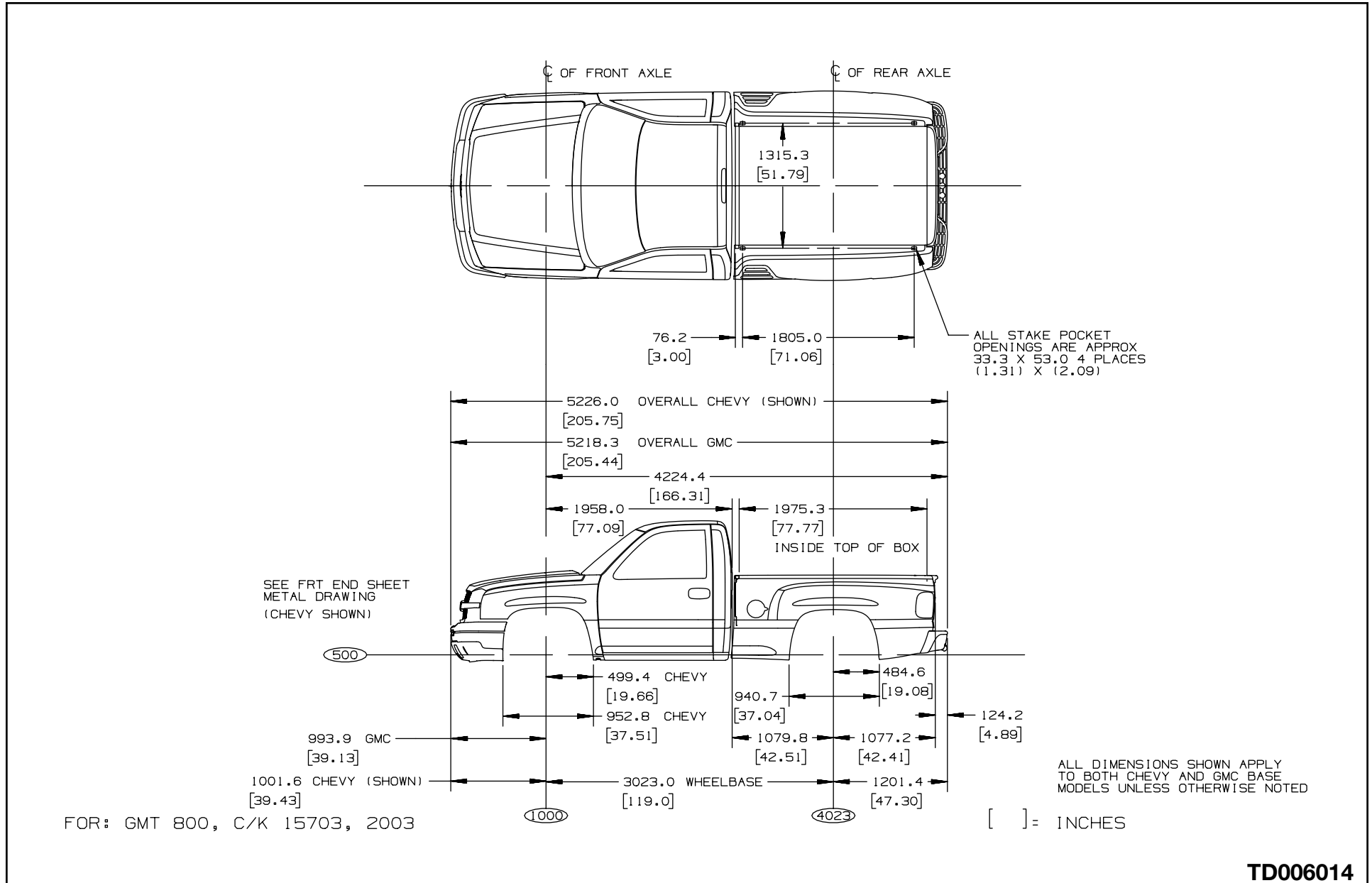

TD006014

2005 & BEYOND C/K FULL SIZE TRUCKS (PICKUPS, UTILITIES AND CHASSIS-CABS)

C/K (15/25HD)753 Extended Cab with Short Box (Option E63)

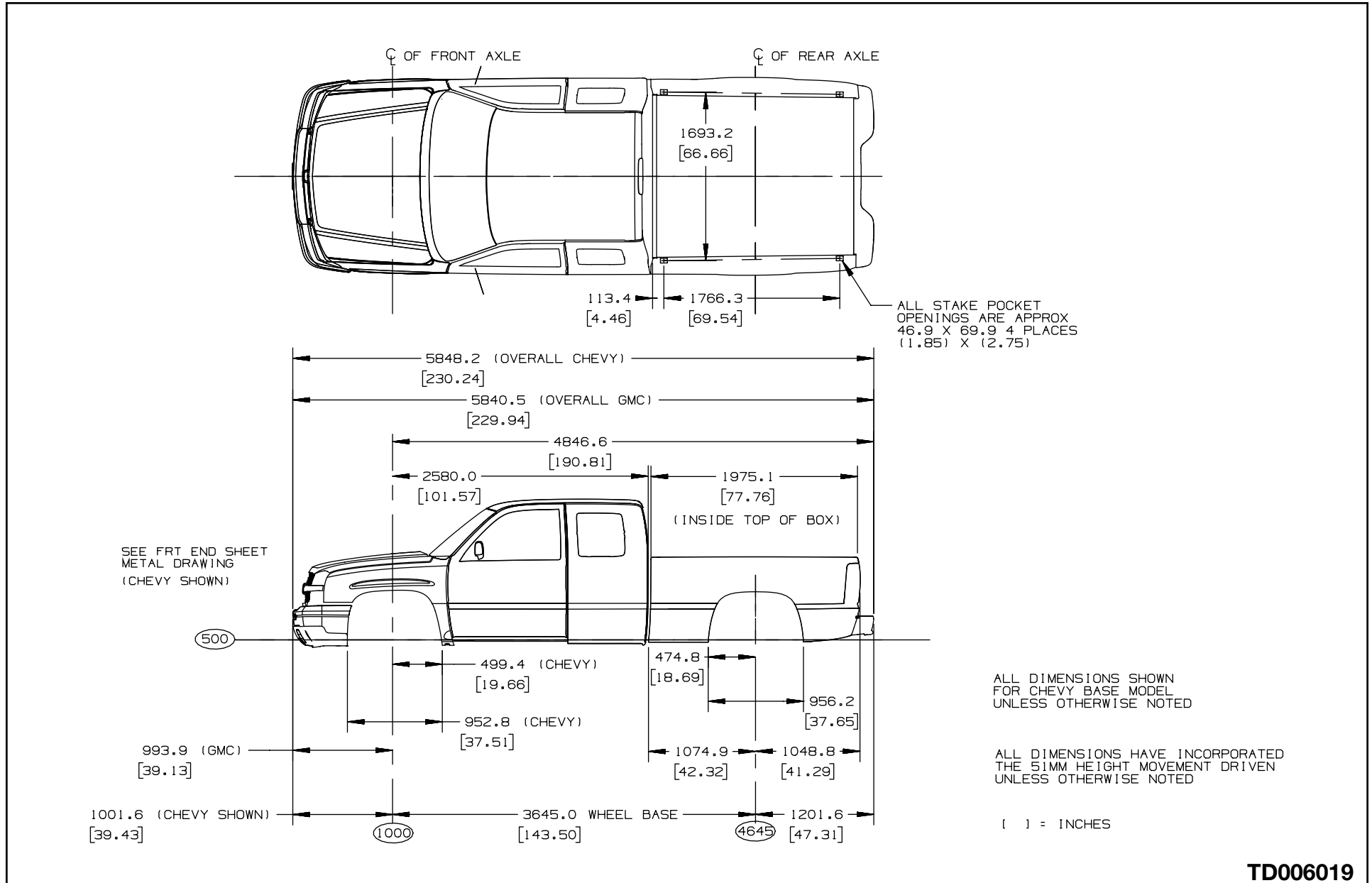

TD006019

2005 & BEYOND C/K FULL SIZE TRUCKS (PICKUPS, UTILITIES AND CHASSIS-CABS)

C/K (15/25/25HD/35)953 Extended Cab with Long Box (Option E63)

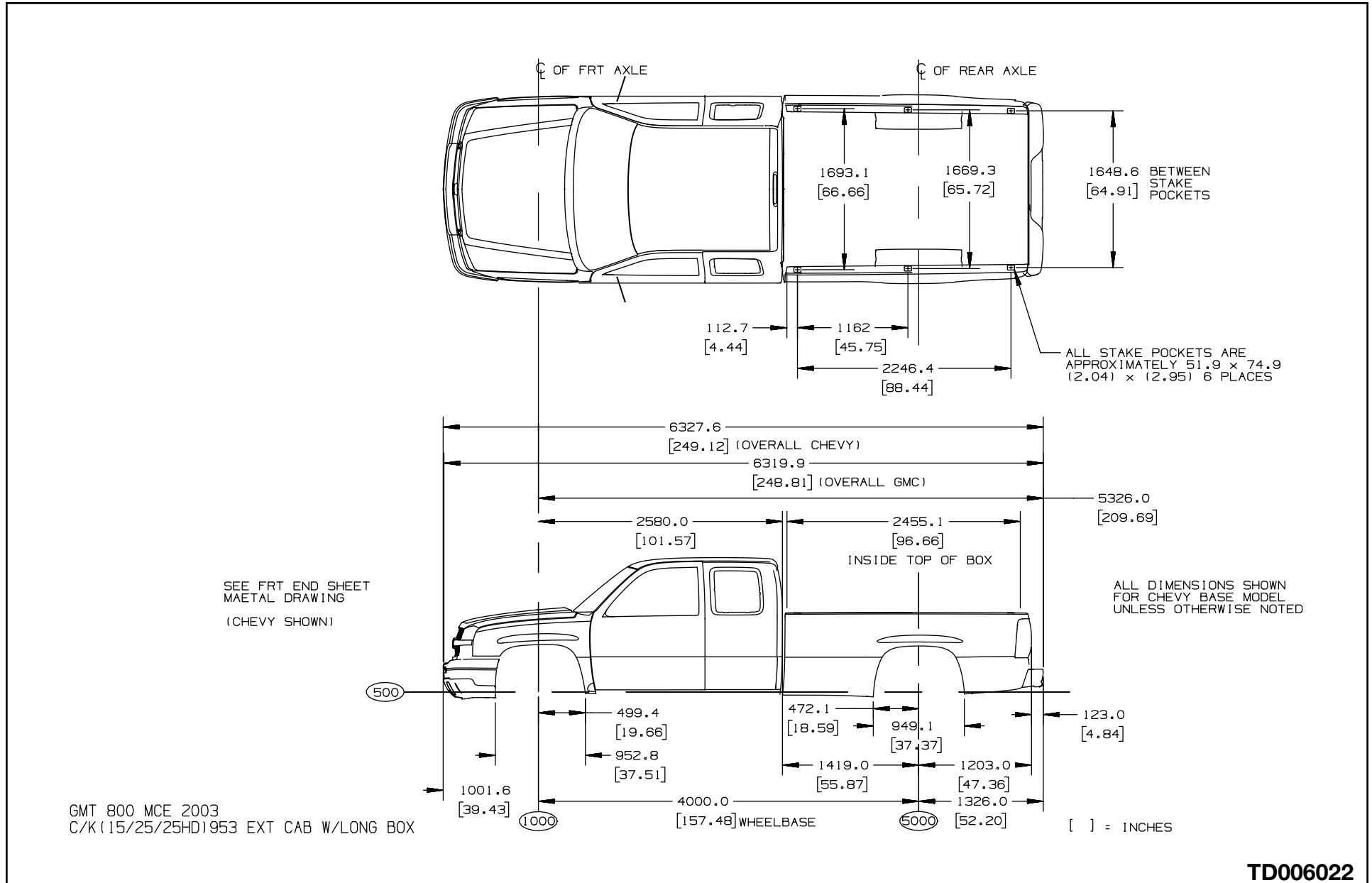

TD006022

C/K 15753 Extended Cab, Sportside (Option E62)

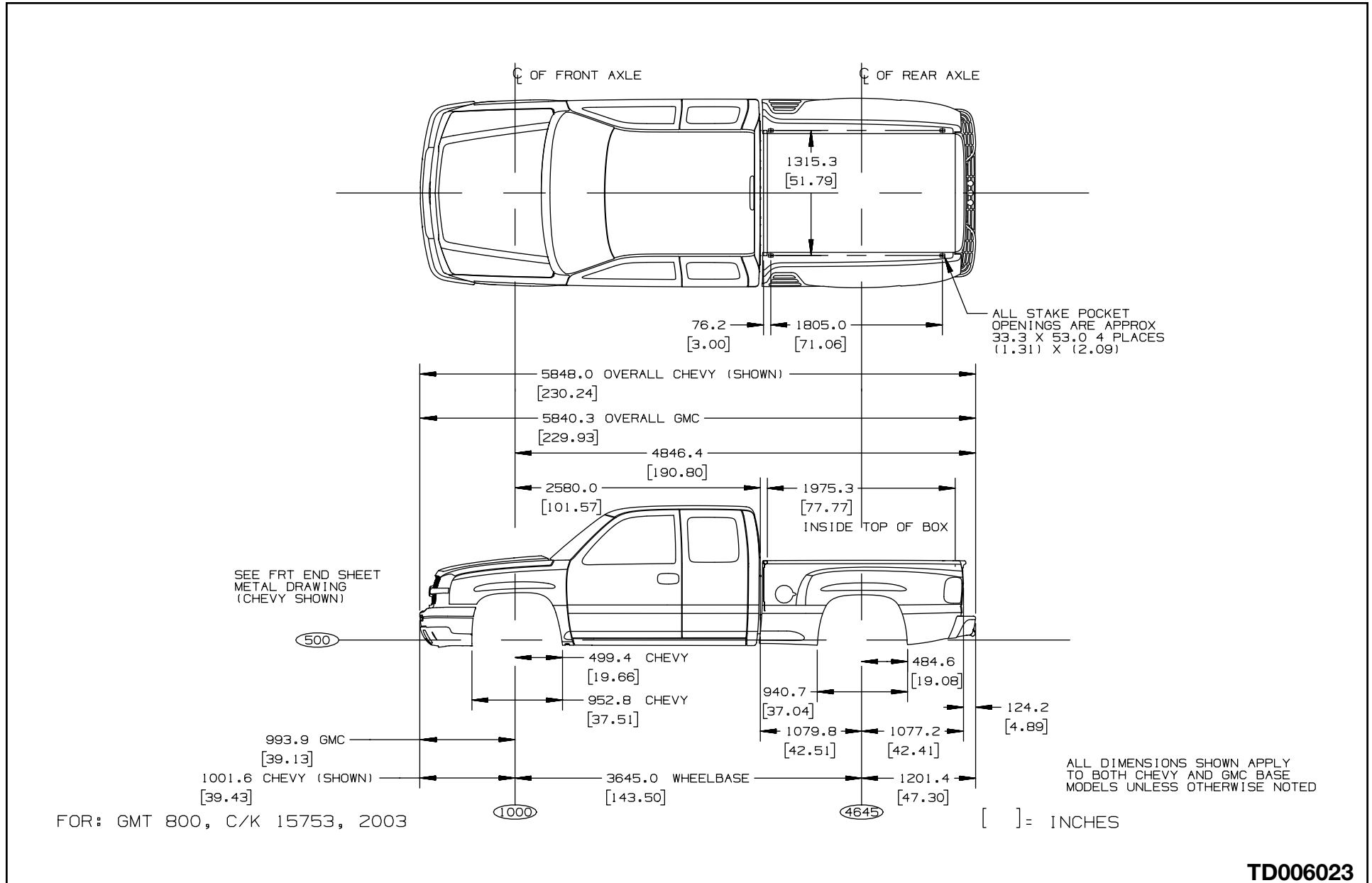

TD006023

2005 & BEYOND C/K FULL SIZE TRUCKS (PICKUPS, UTILITIES AND CHASSIS-CABS)

C/K 15543 Crew Cab with Short Short Box (Option E63) (Chevy)

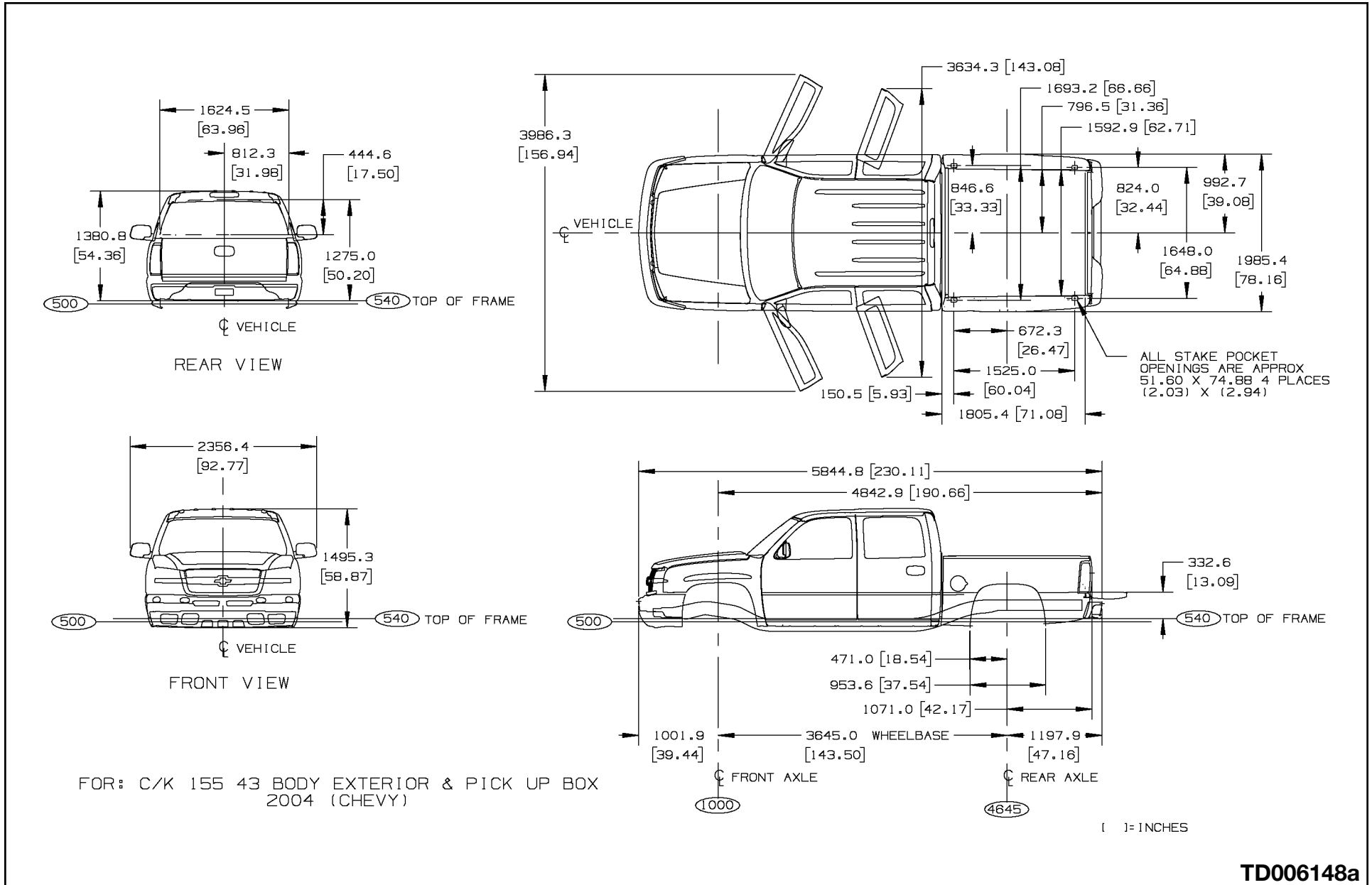

TD006148a

C/K 15543 Crew Cab with Short Short Box (Option E63) (GMC)

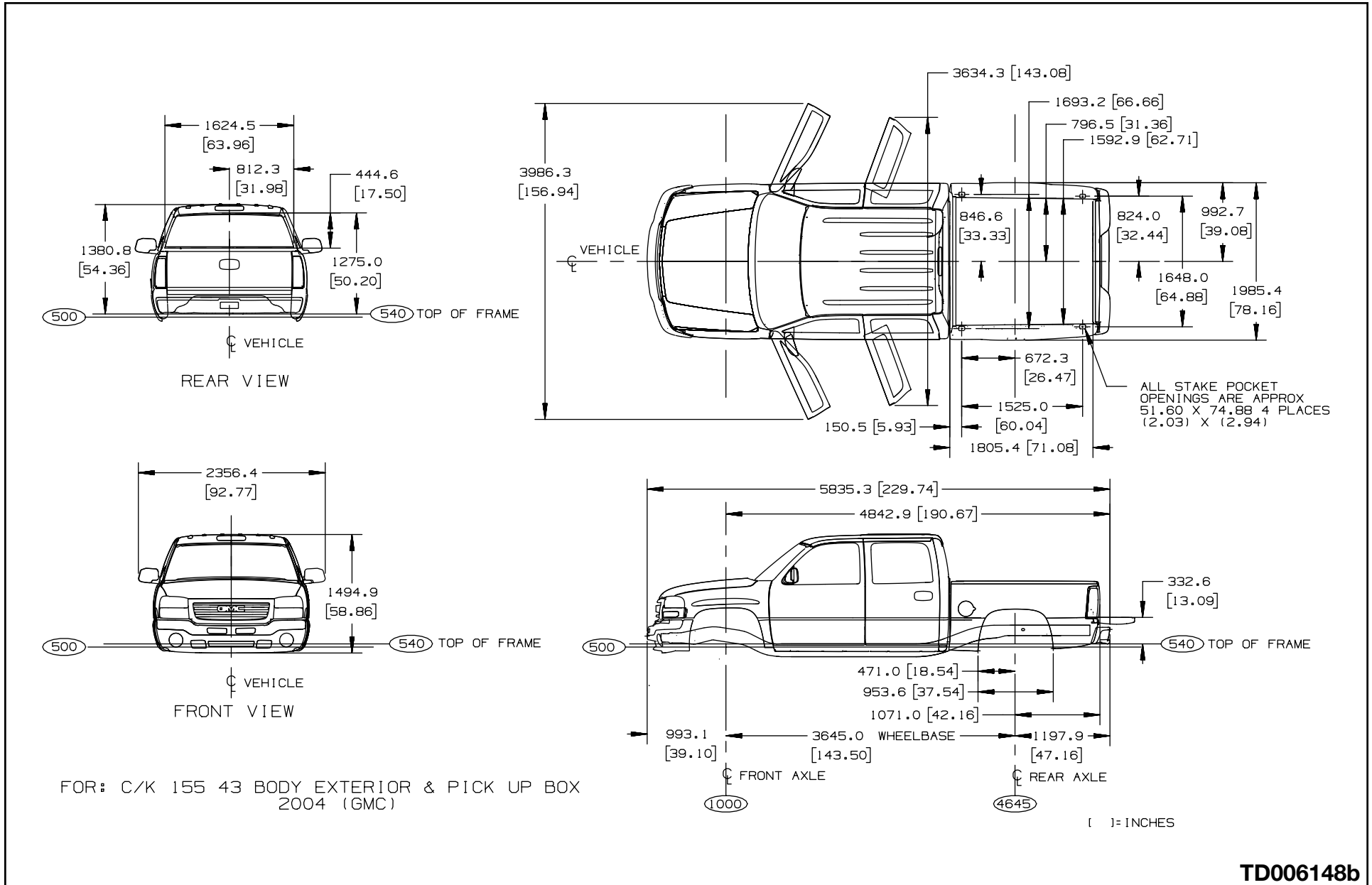

TD006148b

2005 & BEYOND C/K FULL SIZE TRUCKS (PICKUPS, UTILITIES AND CHASSIS-CABS)

C/K (25/25HD)743 Crew Cab with Short Box (Option E63)

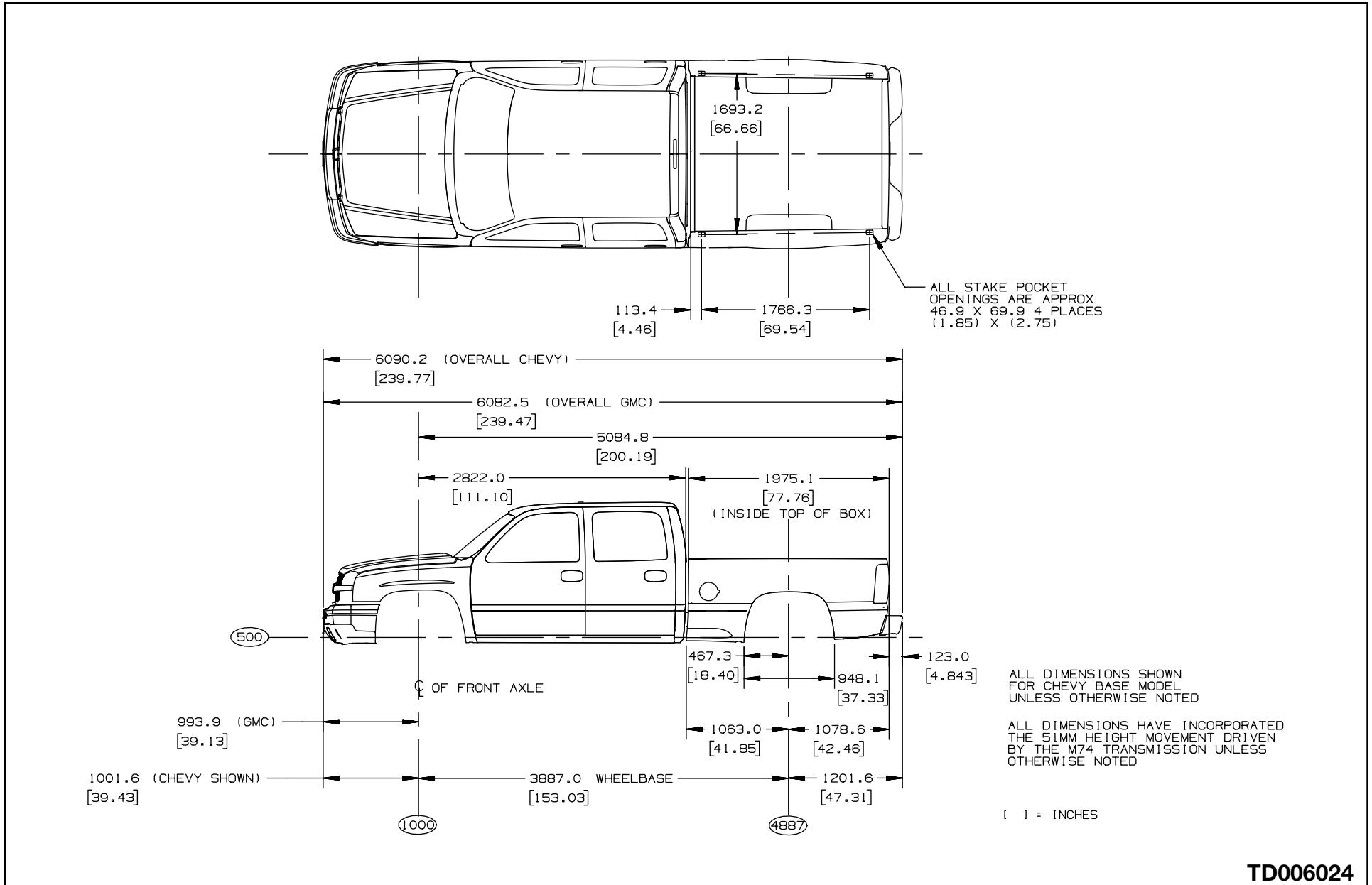

TD006024

2005 & BEYOND C/K FULL SIZE TRUCKS (PICKUPS, UTILITIES AND CHASSIS-CABS)

C/K (25HD/35)943 Crew Cab with Long Box (Option E63)

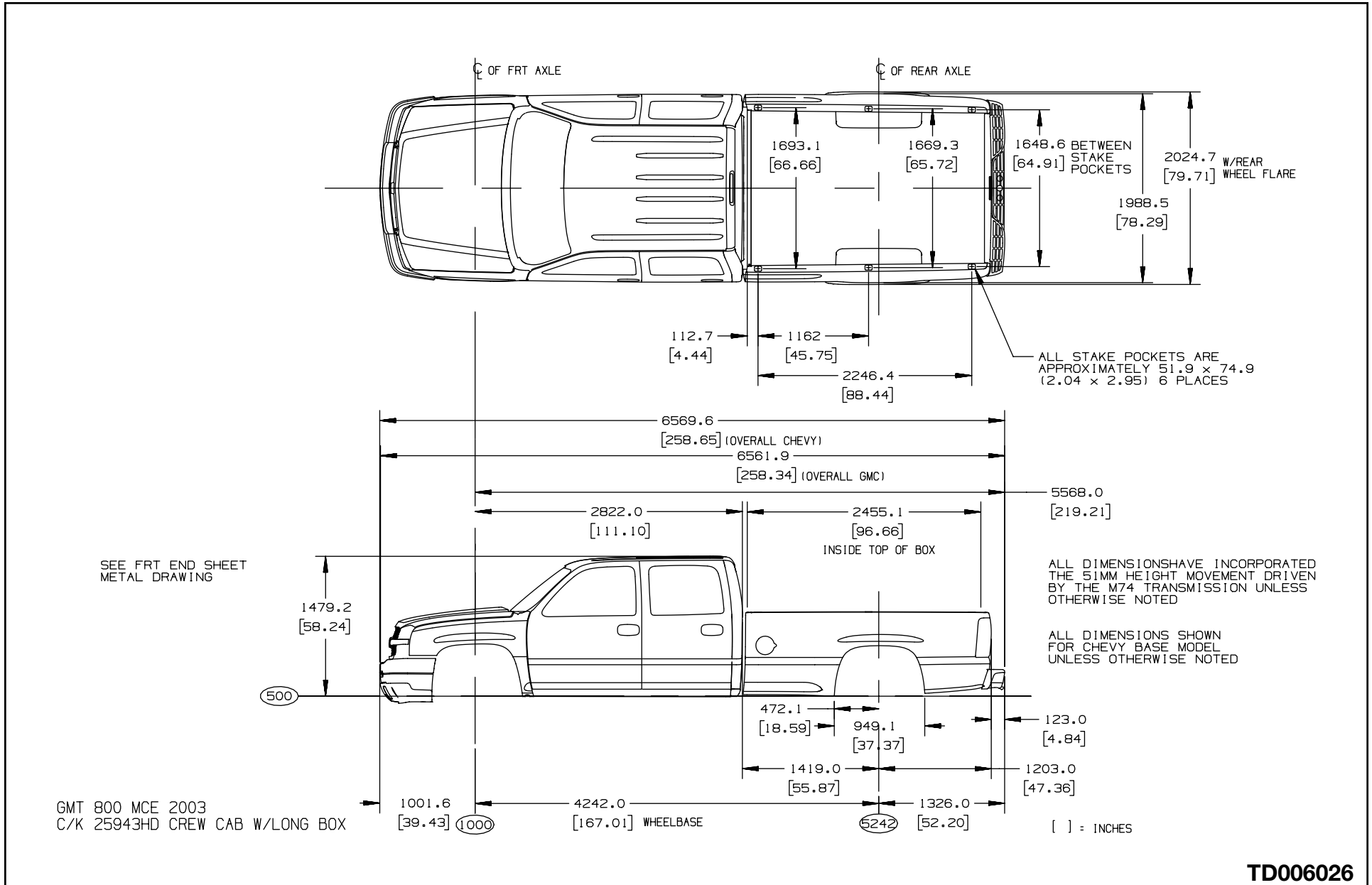

TD006026

2005 & BEYOND C/K FULL SIZE TRUCKS (PICKUPS, UTILITIES AND CHASSIS-CABS)

C/K 35903 Regular Cab with Long Box Dooley (Option E63)

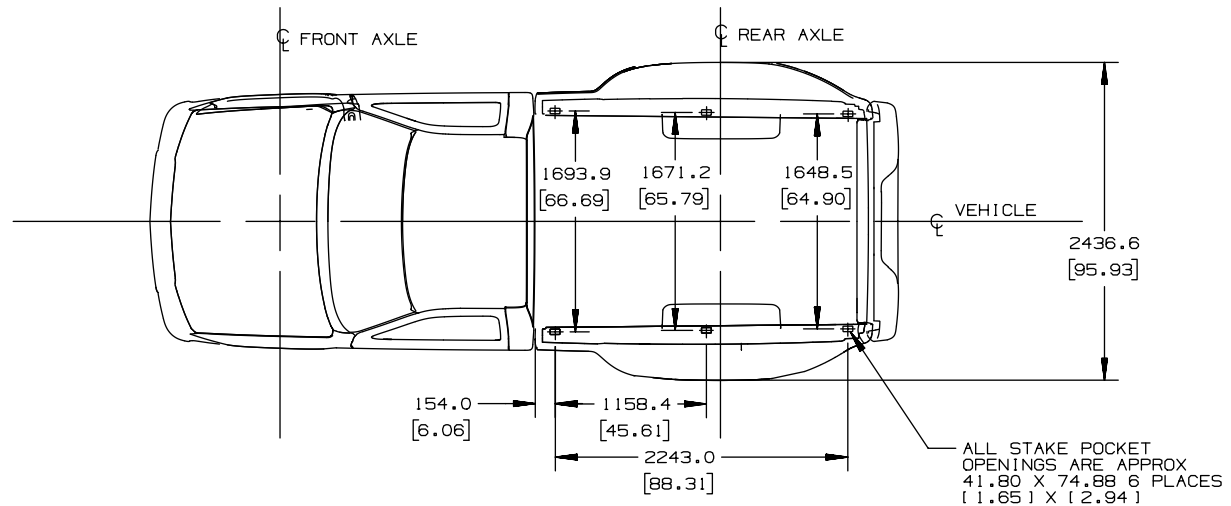

ALL STAKE POCKET OPENINGS ARE APPROX 41.80 X 74.88 6 PLACES (1.65) X (2.94)

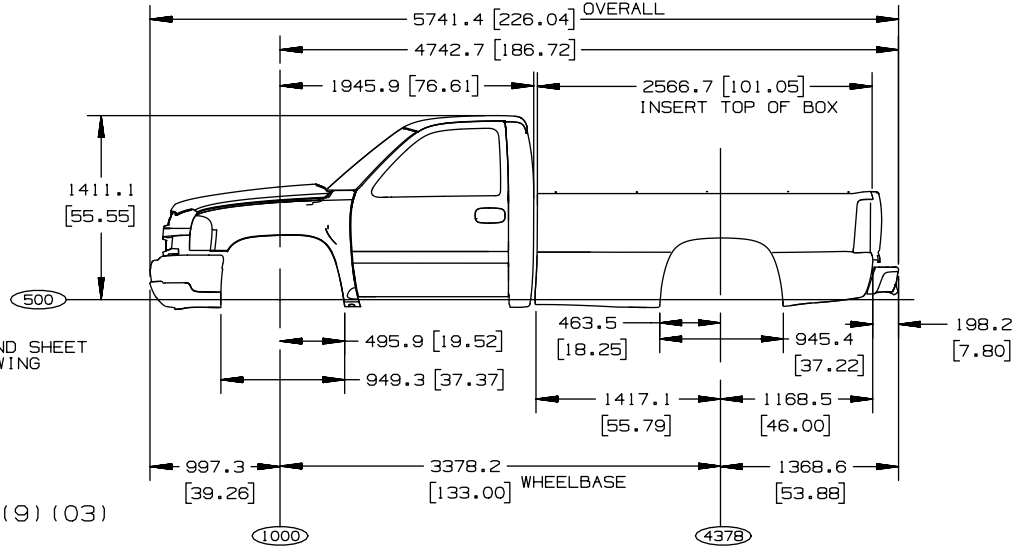

ALL DIMENSIONS SHOWN FOR CHEVY BASE MODEL UNLESS OTHERWISE NOTED

SEE FRT END SHEET METAL DRAWING

FOR: GMT 800 C/K (35) (9) (03)

[] = INCHES

2005 & BEYOND C/K FULL SIZE TRUCKS (PICKUPS, UTILITIES AND CHASSIS-CABS)

C/K 35953 Extended Cab with Long Box Dooley (Option E63)

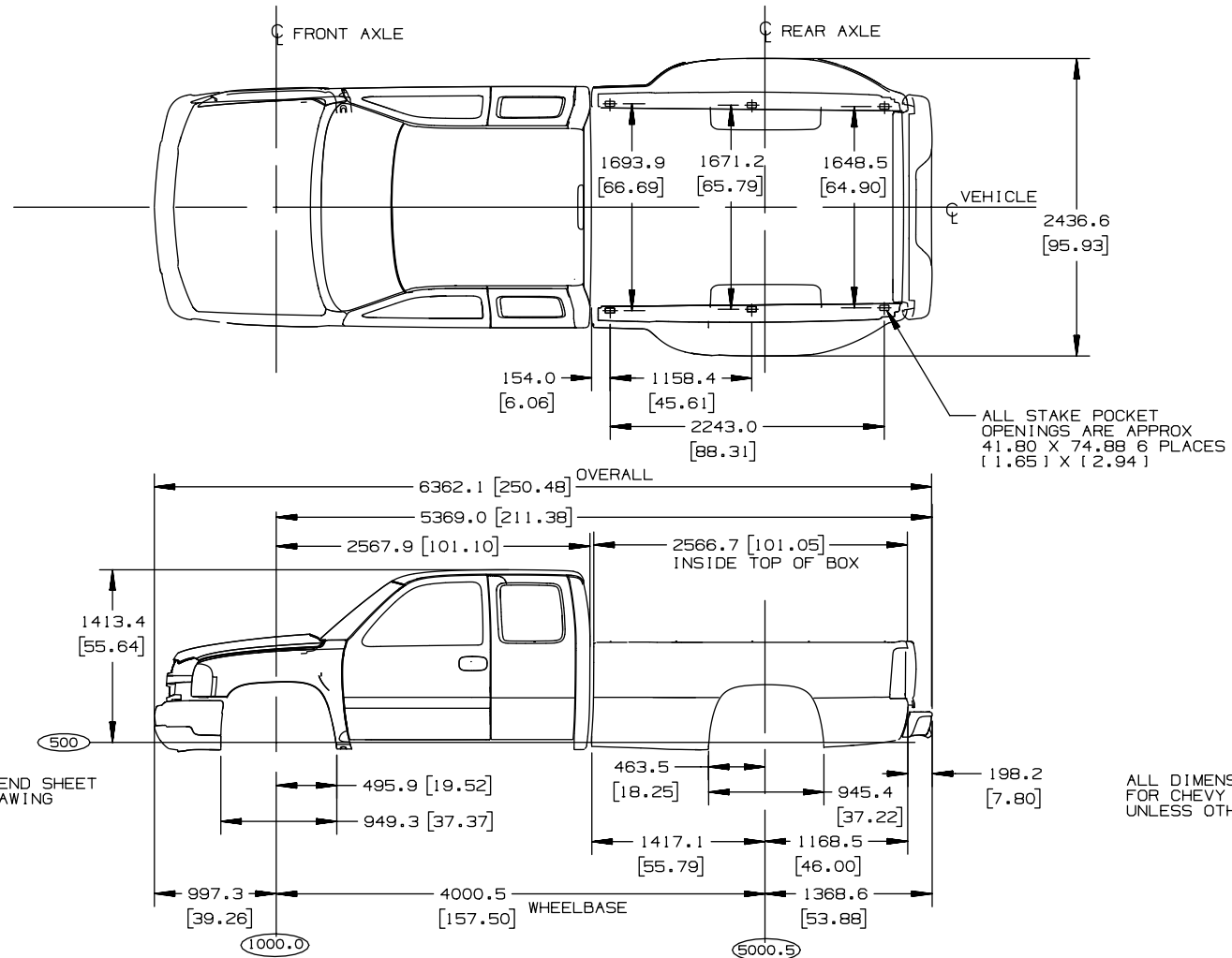

FOR: GMT 800 C/K (35) (9) (53)

[] = INCHES

TD005983b

2005 & BEYOND C/K FULL SIZE TRUCKS (PICKUPS, UTILITIES AND CHASSIS-CABS)

C/K 35943 Crew Cab with Long Box Dooley (Option E63)

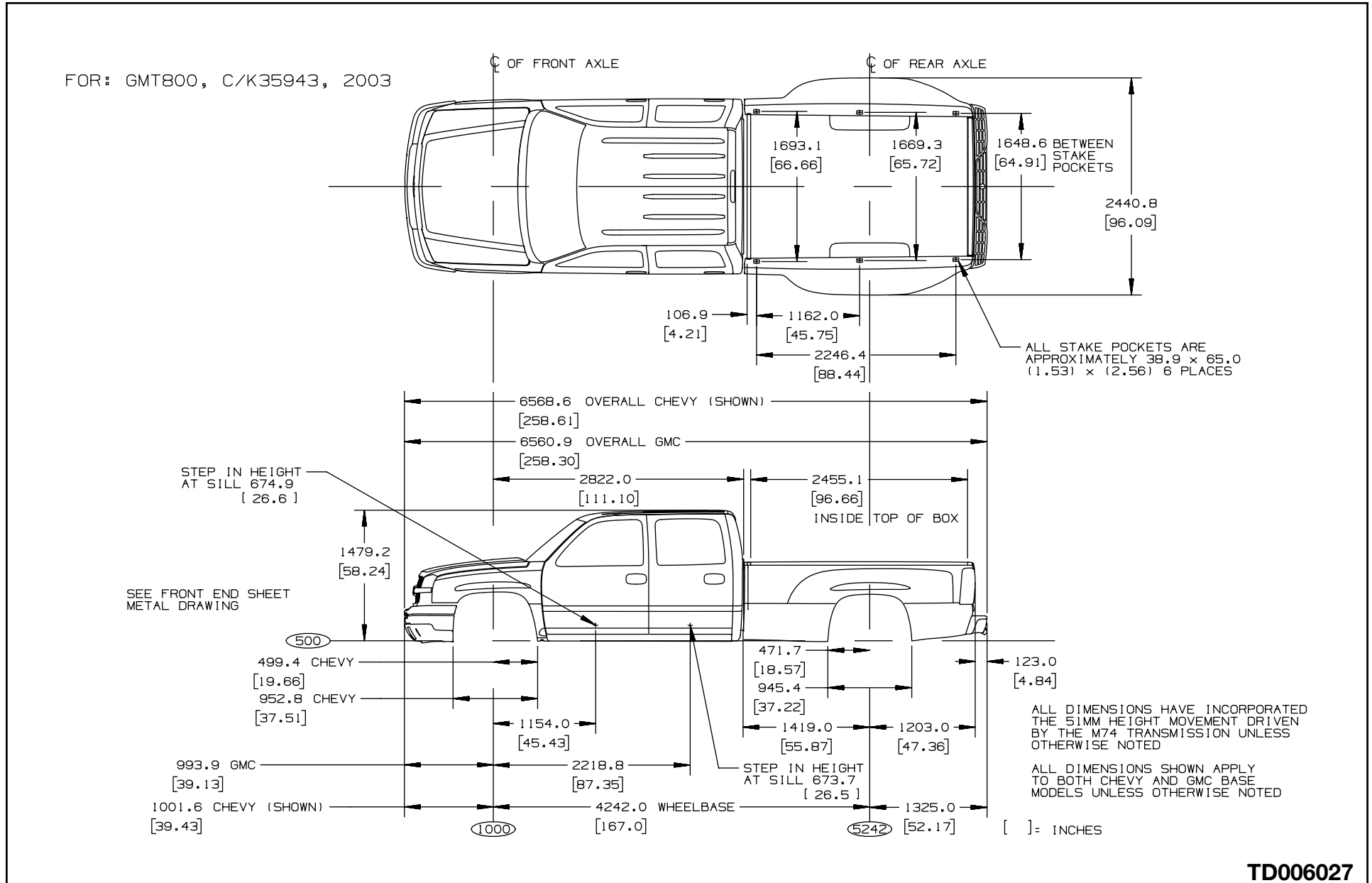

TD006027

C/K 25HD/K35903 Regular Cab (Option ZW9)

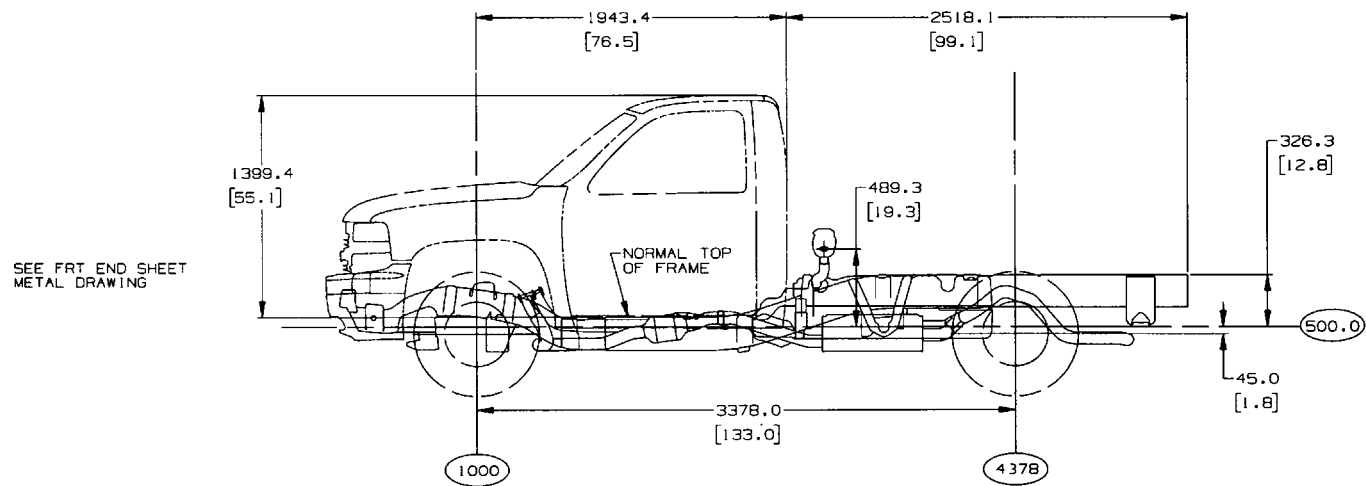
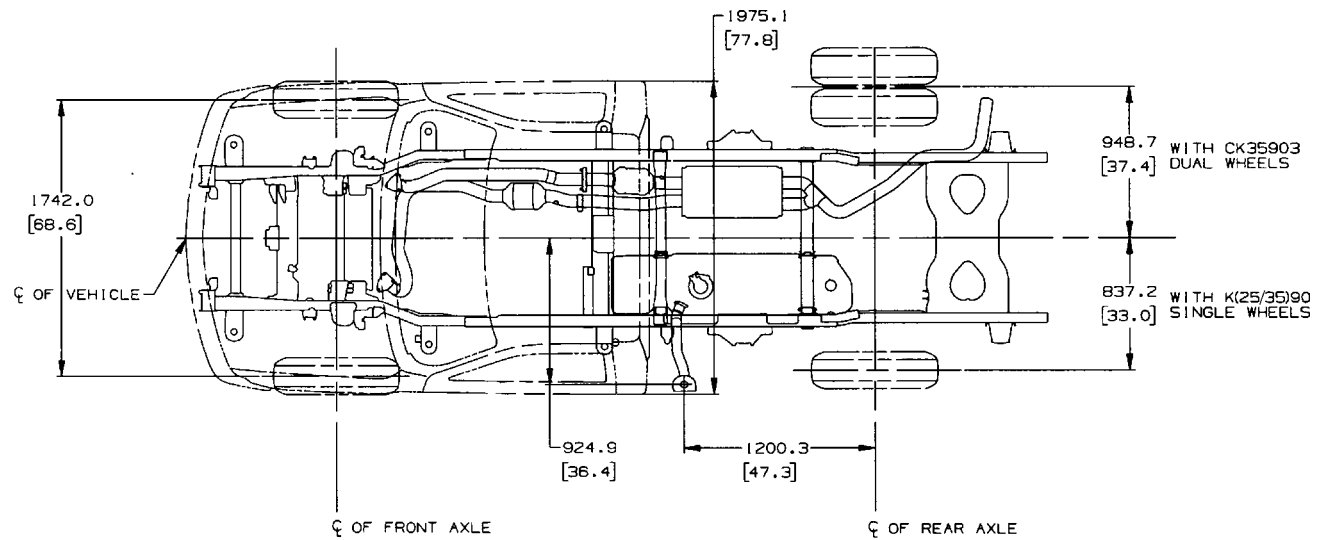

DATA BASED ON 35903
 () = INCHES

TX35903a

K 35953 w/ZW9

**DRAWING
NOT AVAILABLE AT
TIME OF PUBLICATION**

C/K 25HD/35943 Crew Cab (Option ZW9)

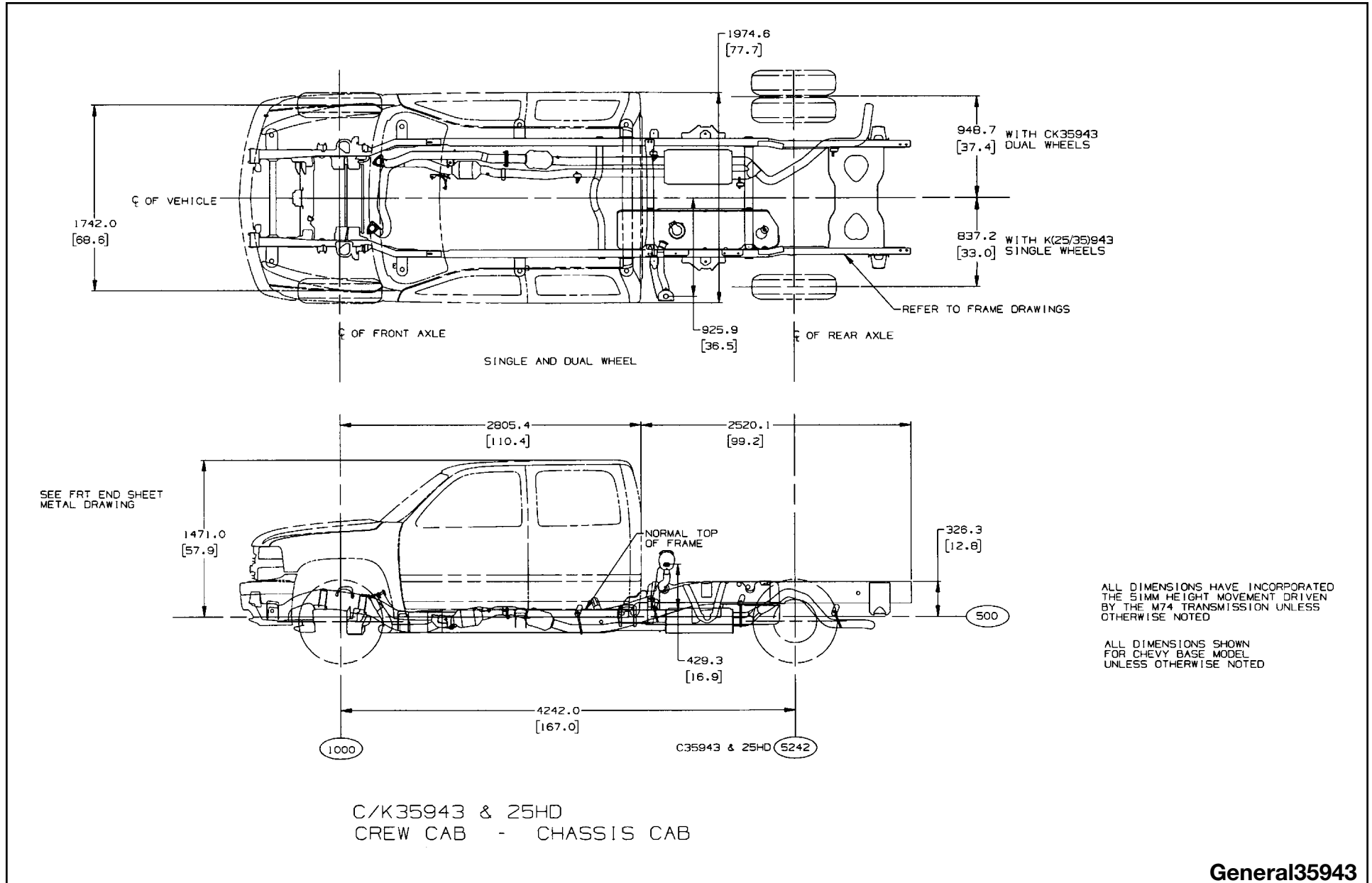

General35943

C/K 36(0/4)03 Regular Cab (Option ZW9)

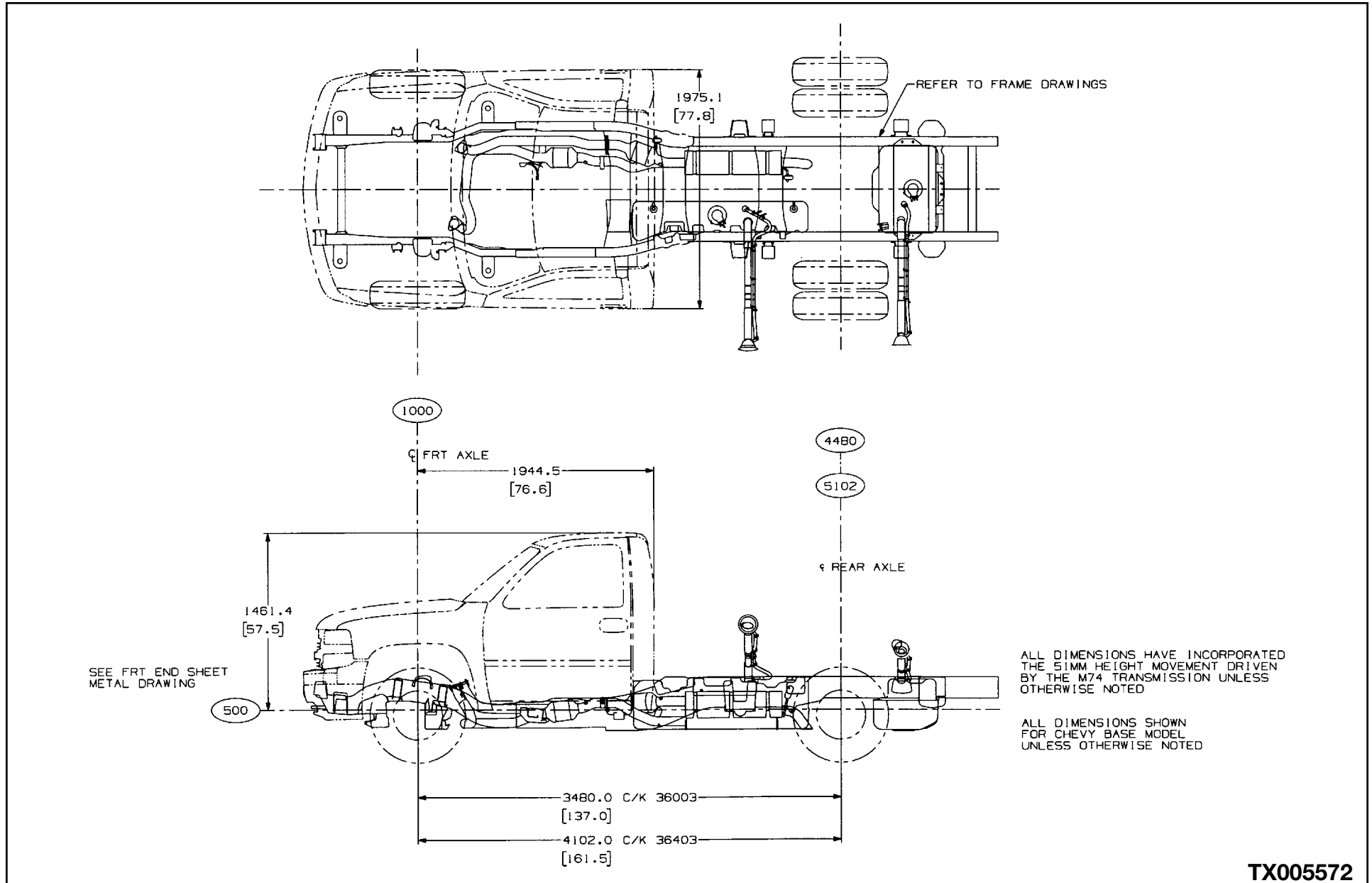

TX005572

C/K 36053 Extended Cab (Option ZW9)

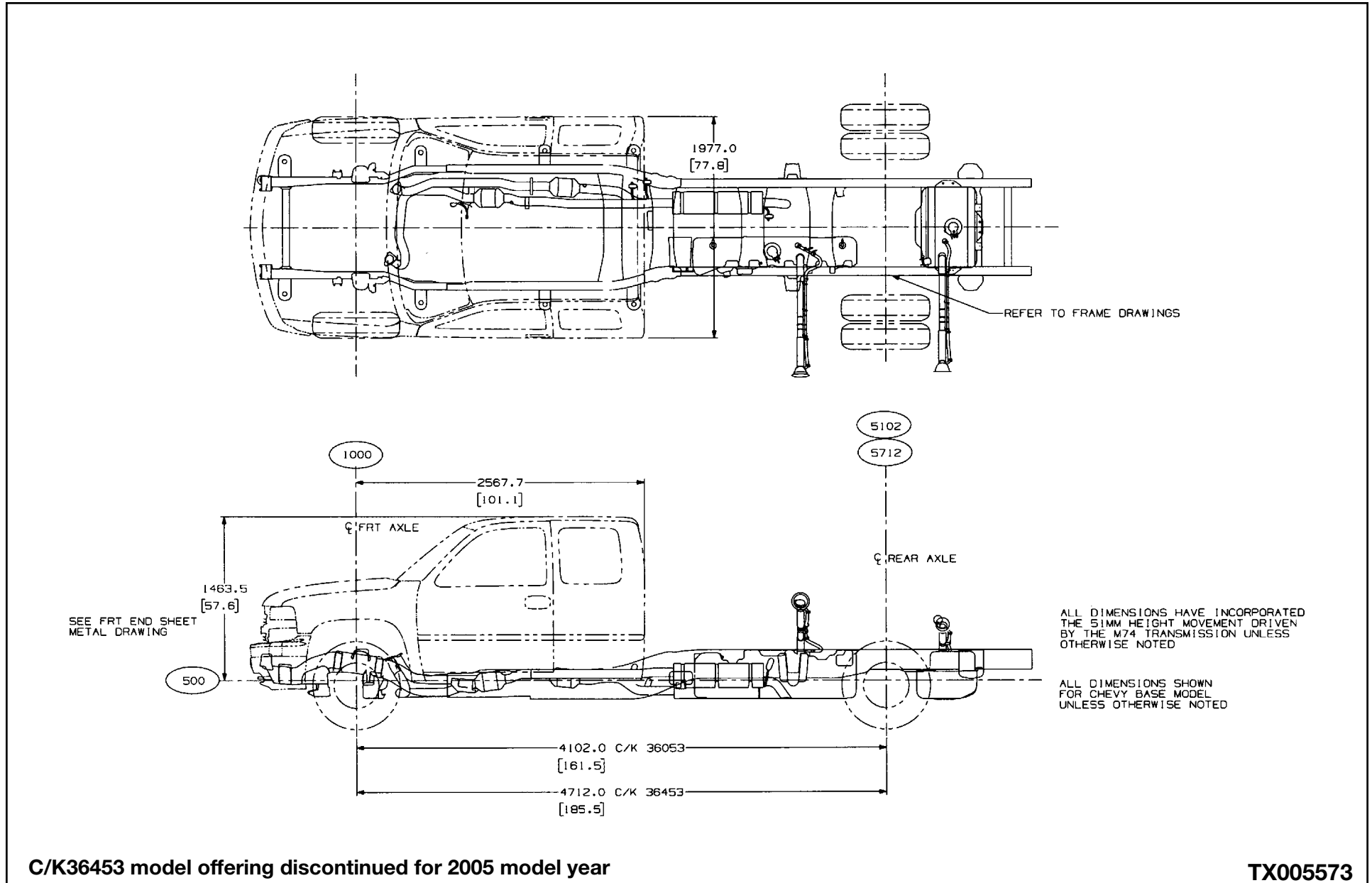

C/K 15706 Tahoe/Yukon

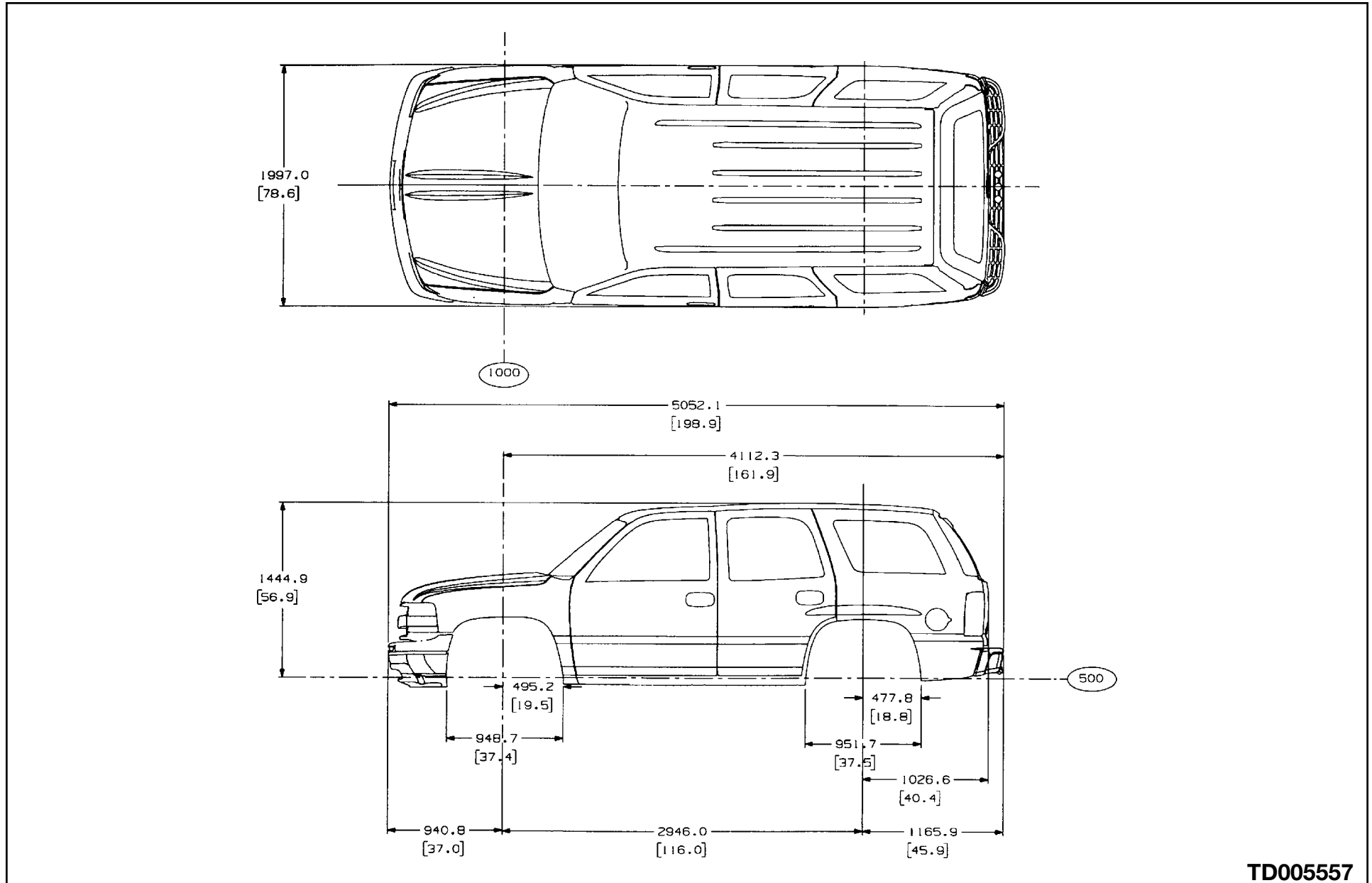

TD005557

C/K (15/25)906 Suburban/Yukon XL

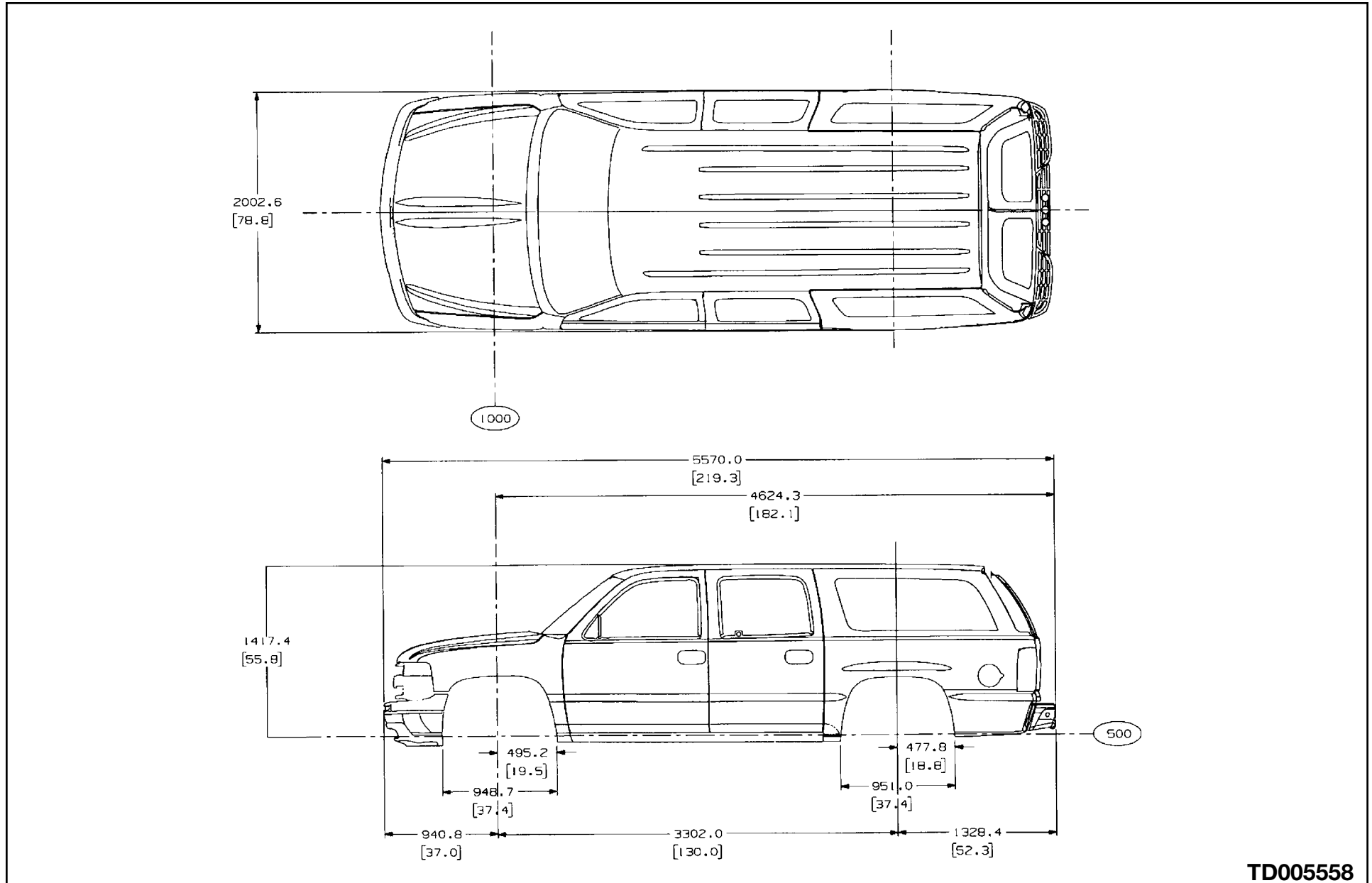

TD005558

C/K (15/25)936 Avalanche

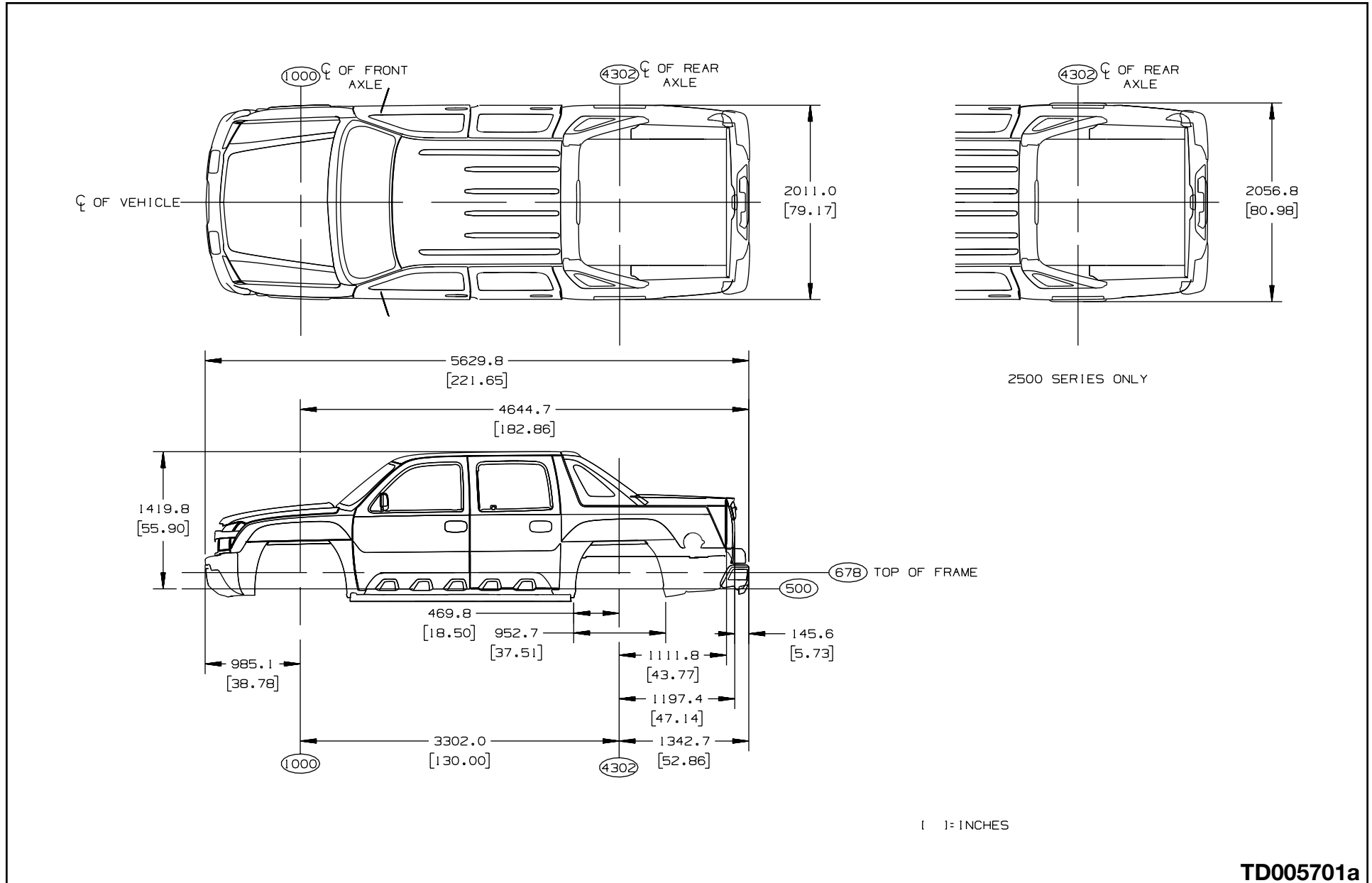

TD005701a

2005 & BEYOND C/K FULL SIZE TRUCKS (PICKUPS, UTILITIES AND CHASSIS-CABS)

C/K (25HD/35/36) Regular Cab CA's

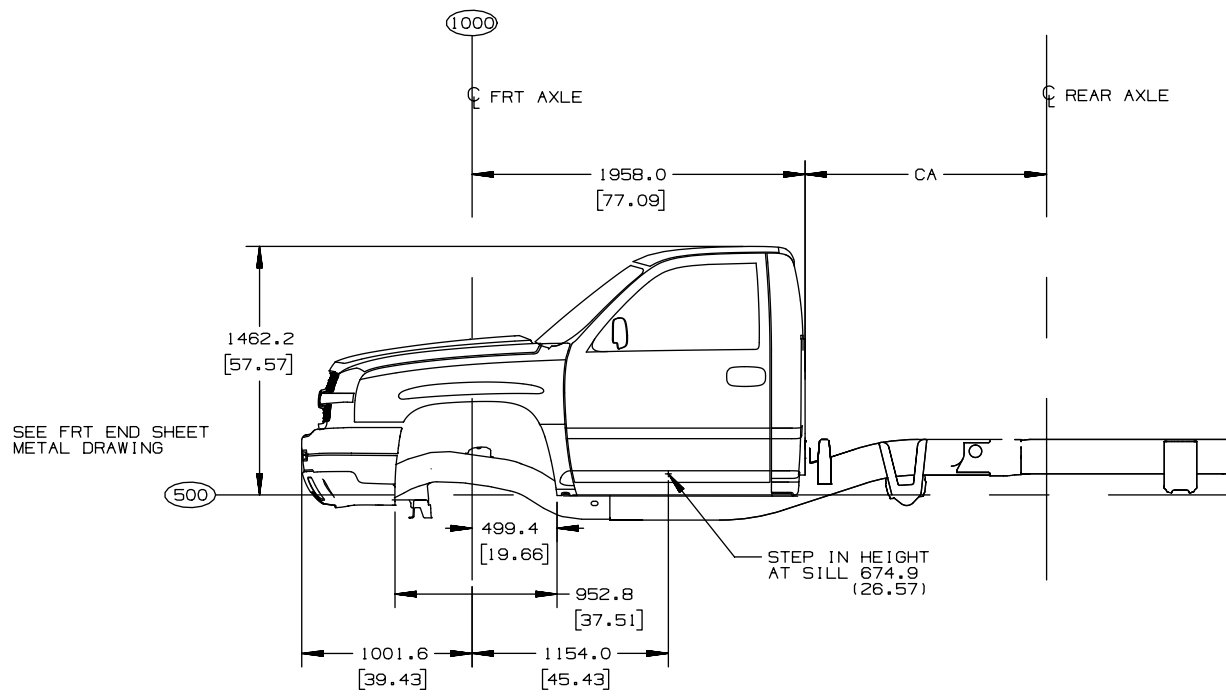

MODEL	WHEEL BASE	CA
25/35903	3378.0 (133.00)	1420.0 (55.90)
36003	3480.0 (137.00)	1522.0 (59.90)
36403	4102.0 (161.50)	2144.0 (84.40)

ALL DIMENSIONS HAVE INCORPORATED THE 51MM HEIGHT MOVEMENT DRIVEN BY THE M74 TRANSMISSION UNLESS OTHERWISE NOTED

ALL DIMENSIONS SHOWN FOR CHEVY BASE MODEL UNLESS OTHERWISE NOTED

* WHEELBASE AVAILABLE

GMT 800 MCE 2003
C/K (25HD/35/36) REG CAB CA'S

[] = INCHES

TD006030a

C/K (25HD/35/36) Extended Cab CA's

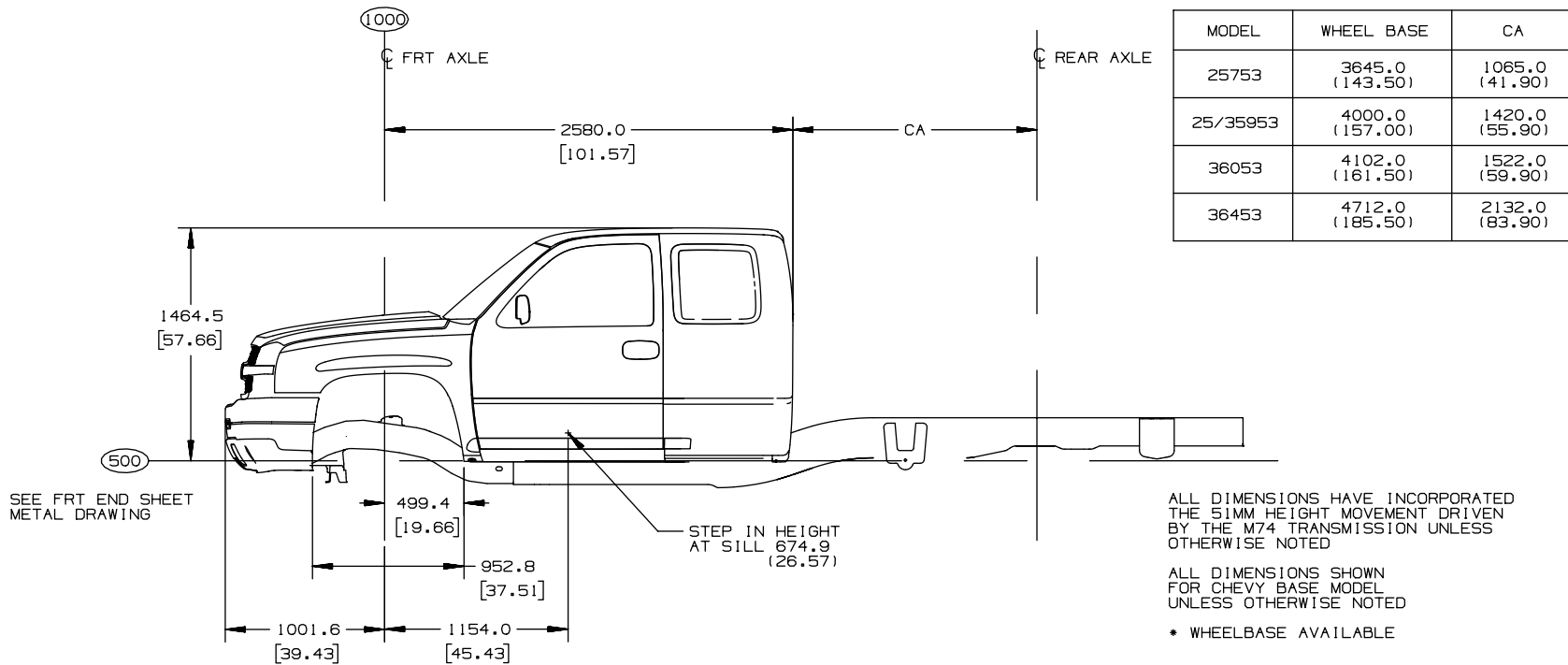

GMT 800 MCE 2003
C/K (25HD/35/36) EXT CAB CA'S

[] = INCHES

C/K (25HD/35) Crew Cab CA's

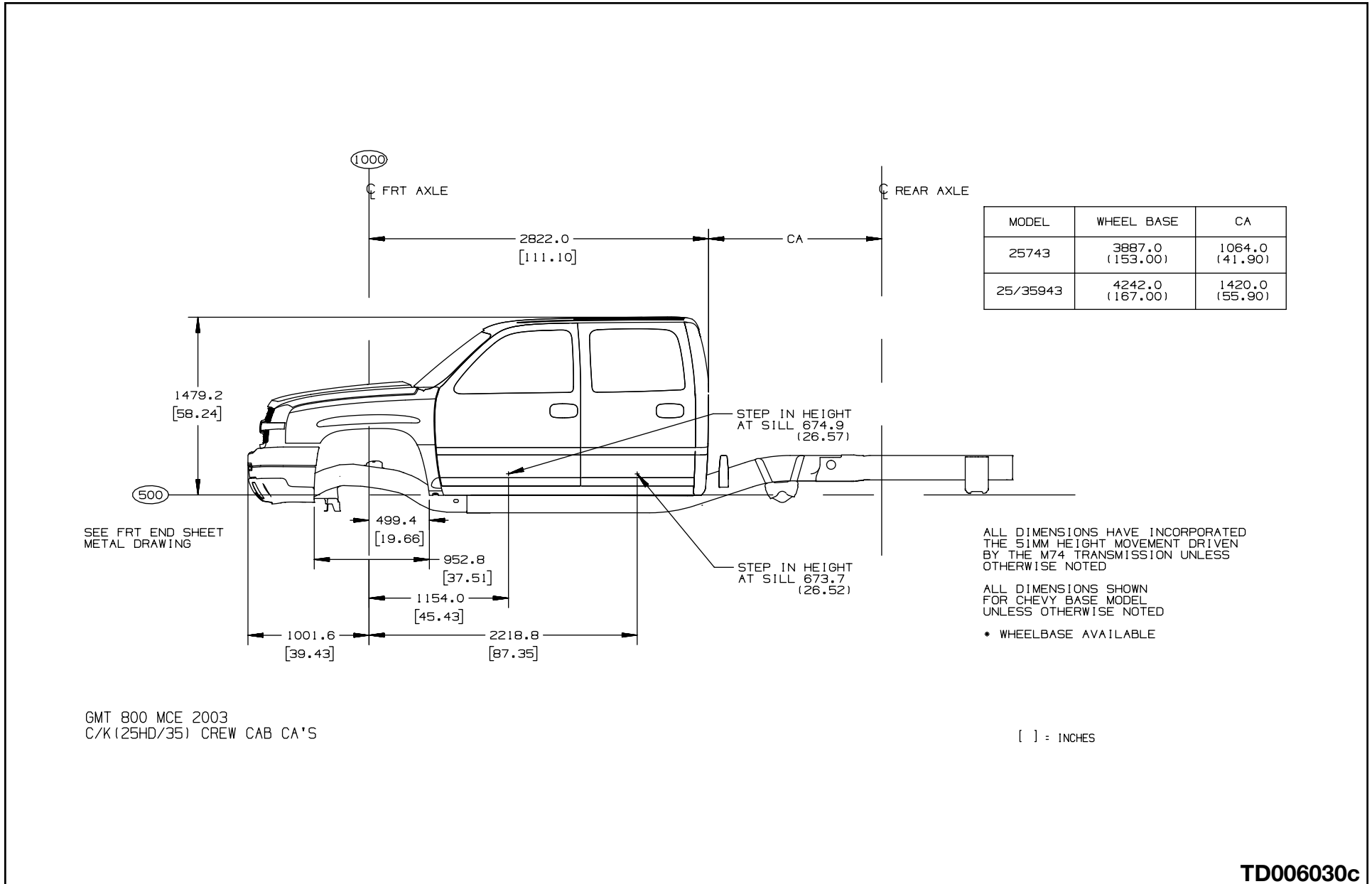

TD006030c

C/K (15/25) Regular Cab Interior

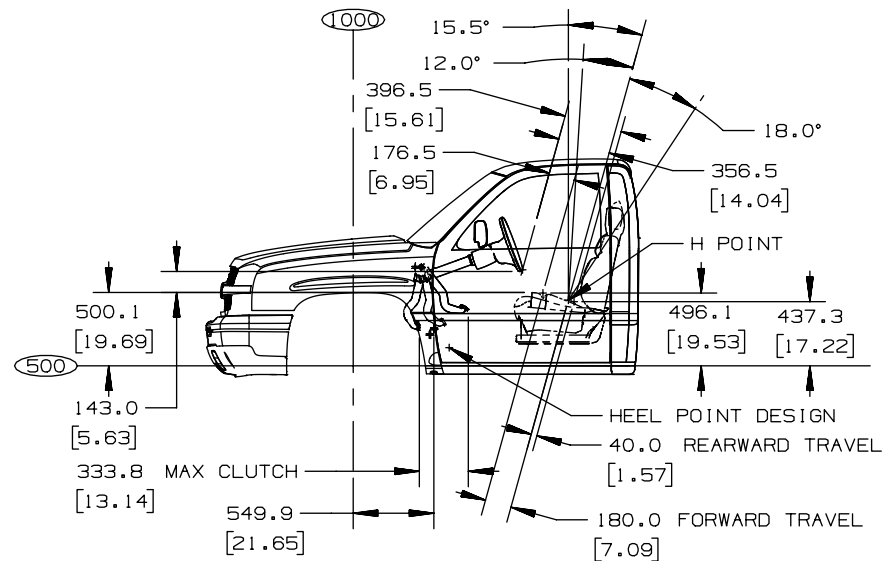
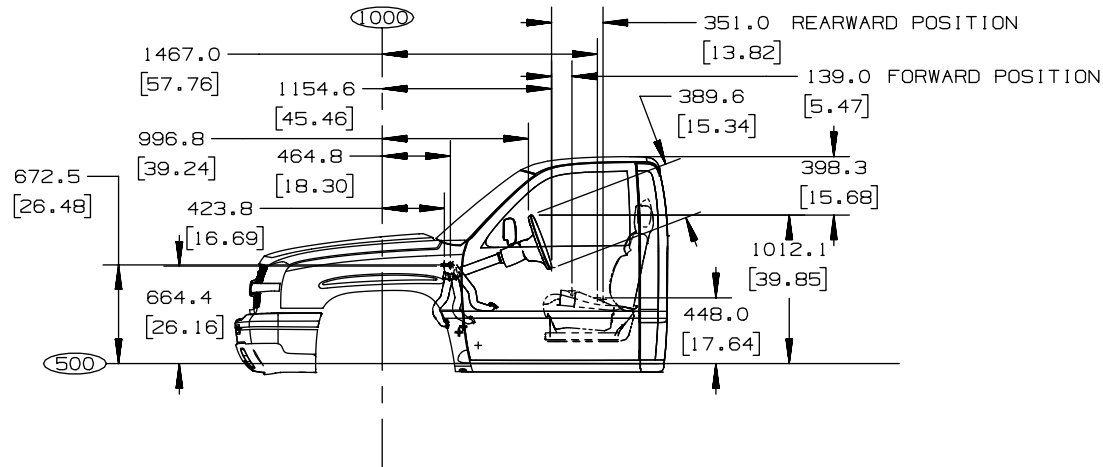

[] = INCHES

TD006036a

C/K (25HD/35/36) Regular Cab Interior

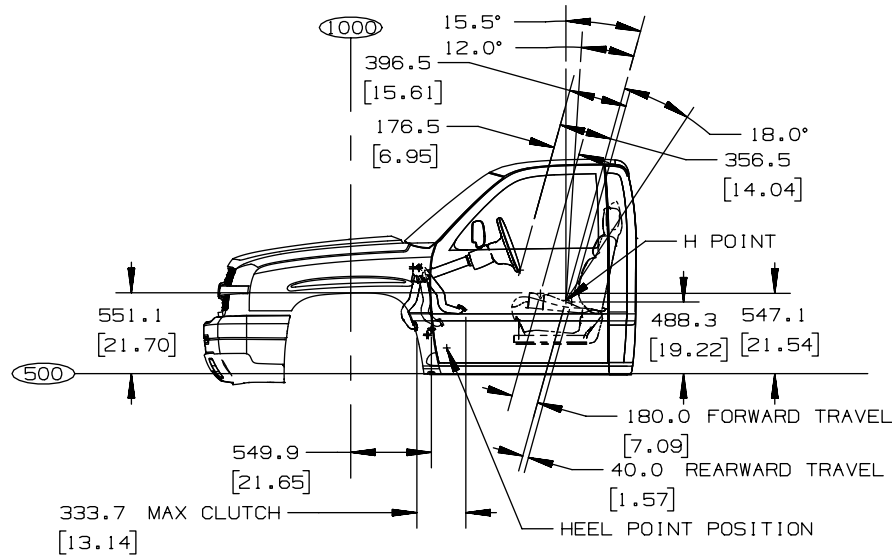
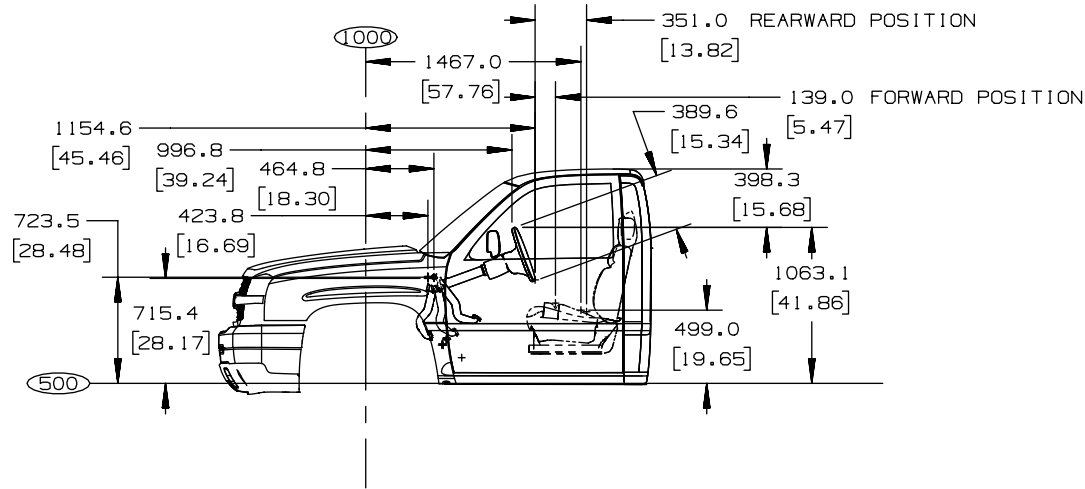

[] = INCHES

TD006036b

C/K (15/25) Extended Cab Interior

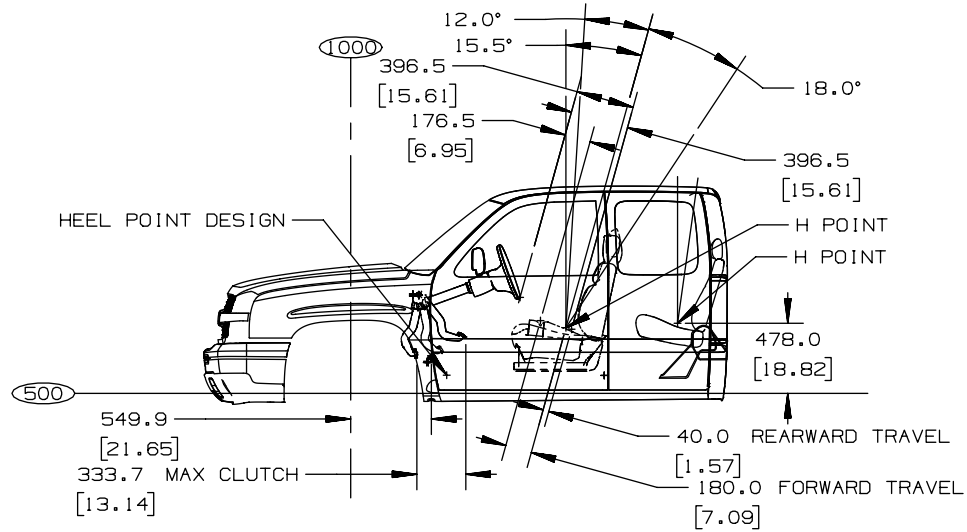
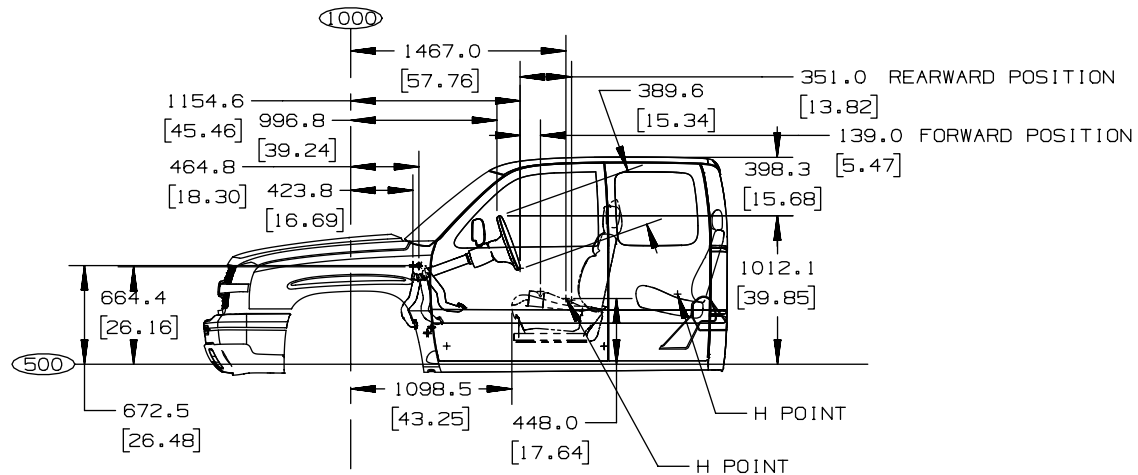

[] = INCHES

TD006036c

C/K (25HD/35/36) Extended Cab Interior

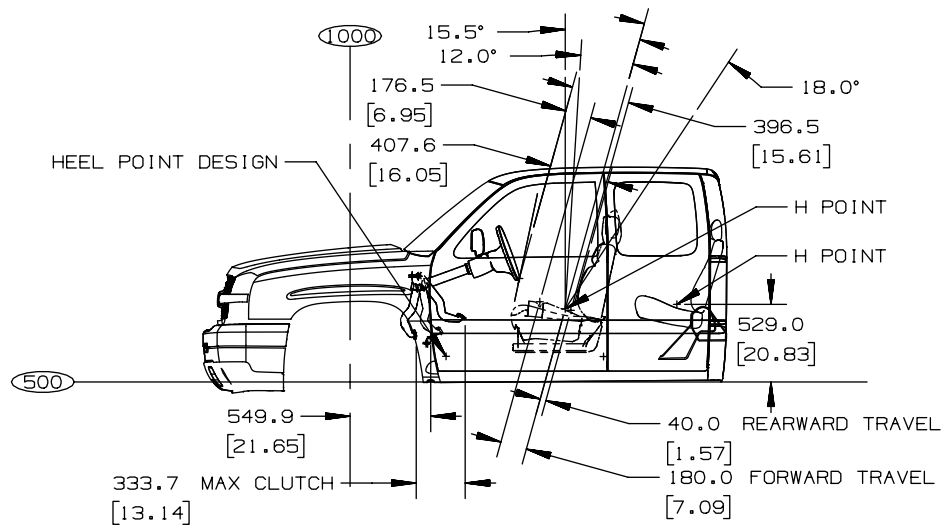
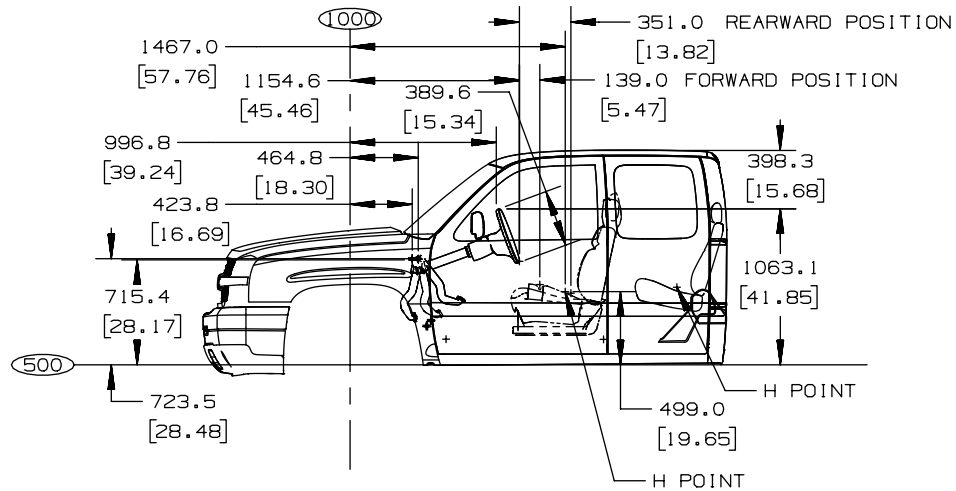

[] = INCHES

TD006036d

C/K (15/25) Crew Cab Interior

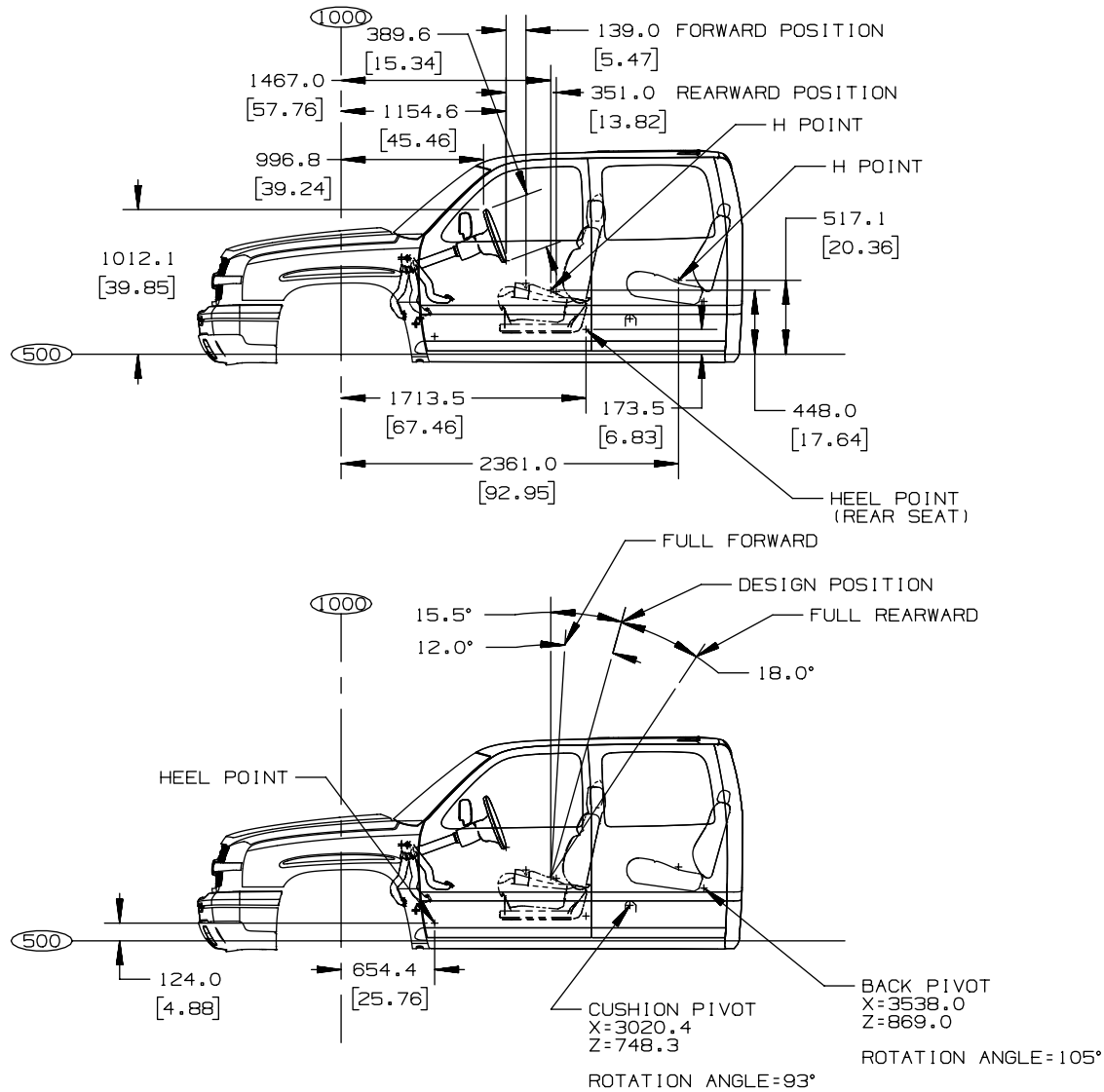

[] = INCHES

TD006036e

C/K (25HD/35/36) Crew Cab Interior

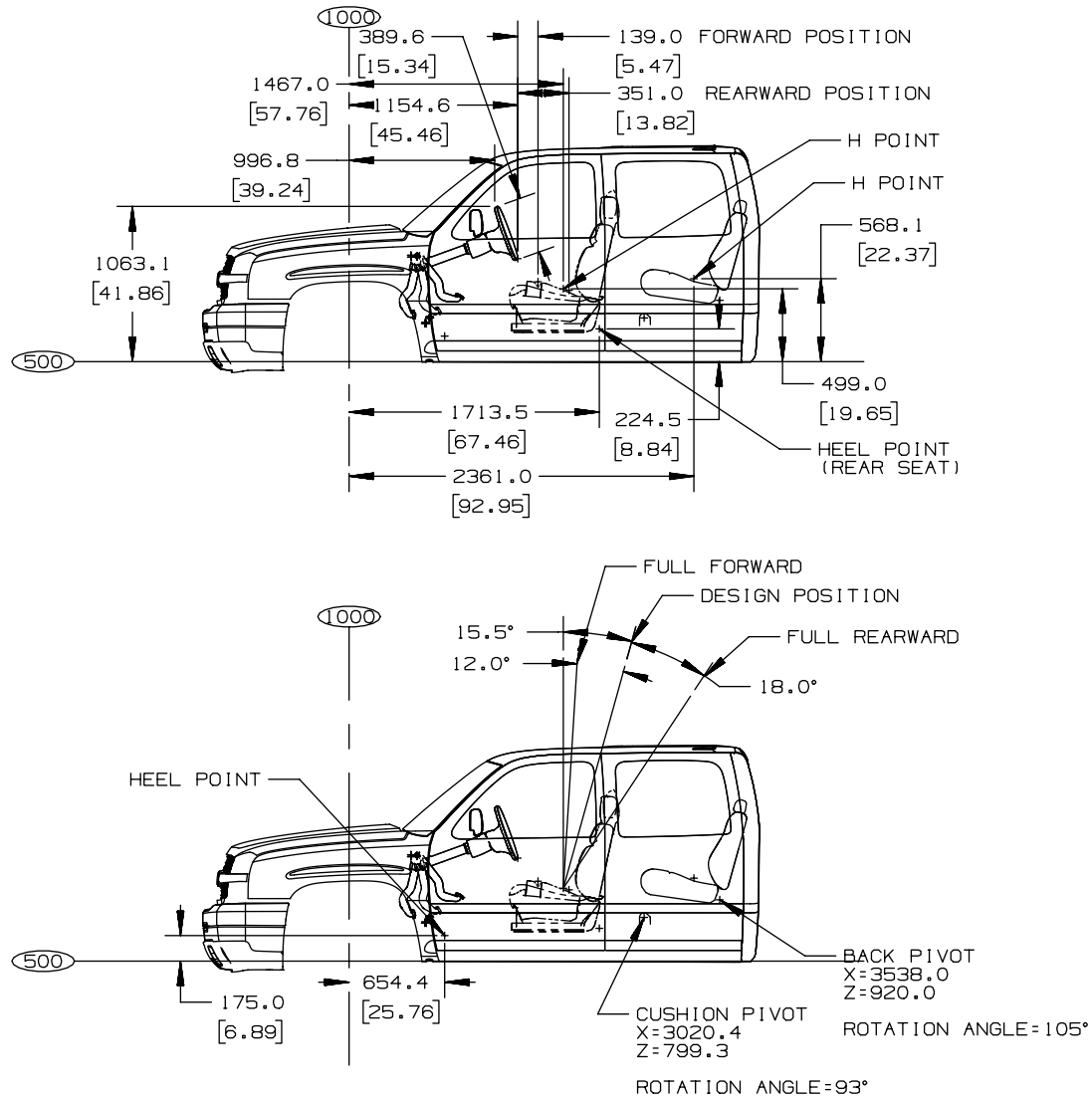

[] = INCHES

TD006036f

C/K (15/25) Regular and Extended Cab Seating Positions

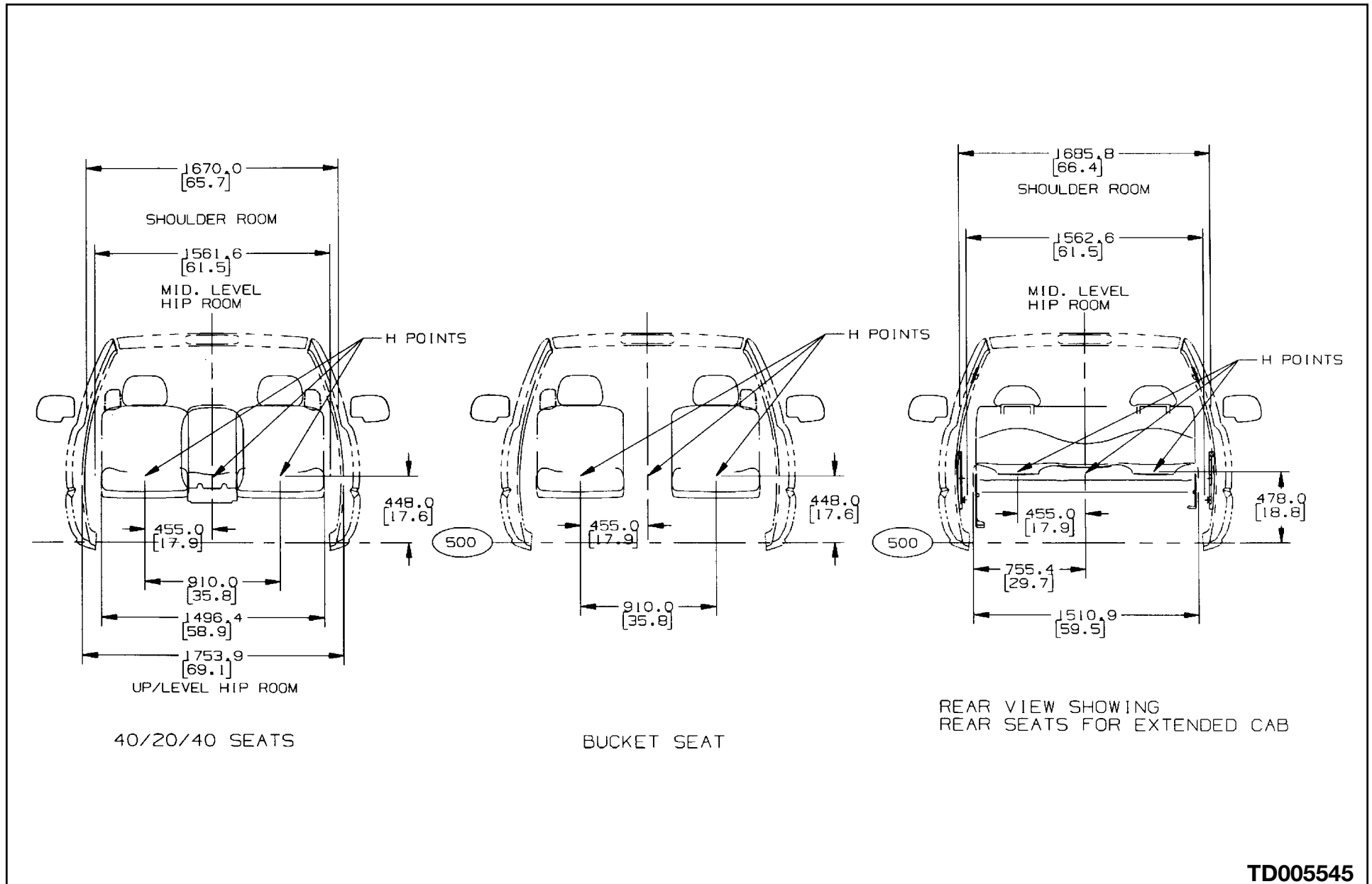

TD005545

C/K (25HD/35/36) Regular and Extended Cab Seating Positions

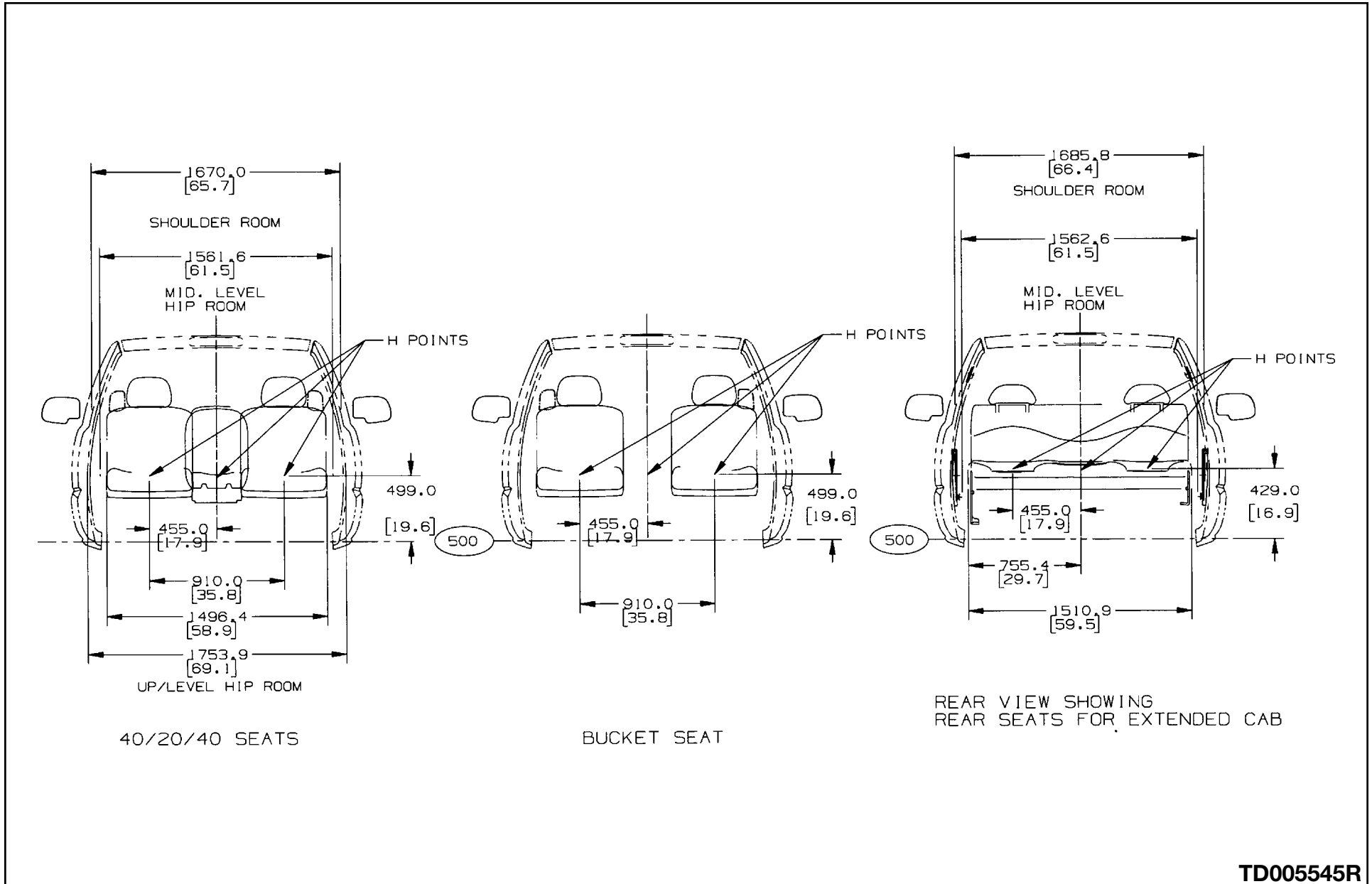

C/K (15/25/25HD/35)(743/943) Crew Cab Second Row Seating Positions

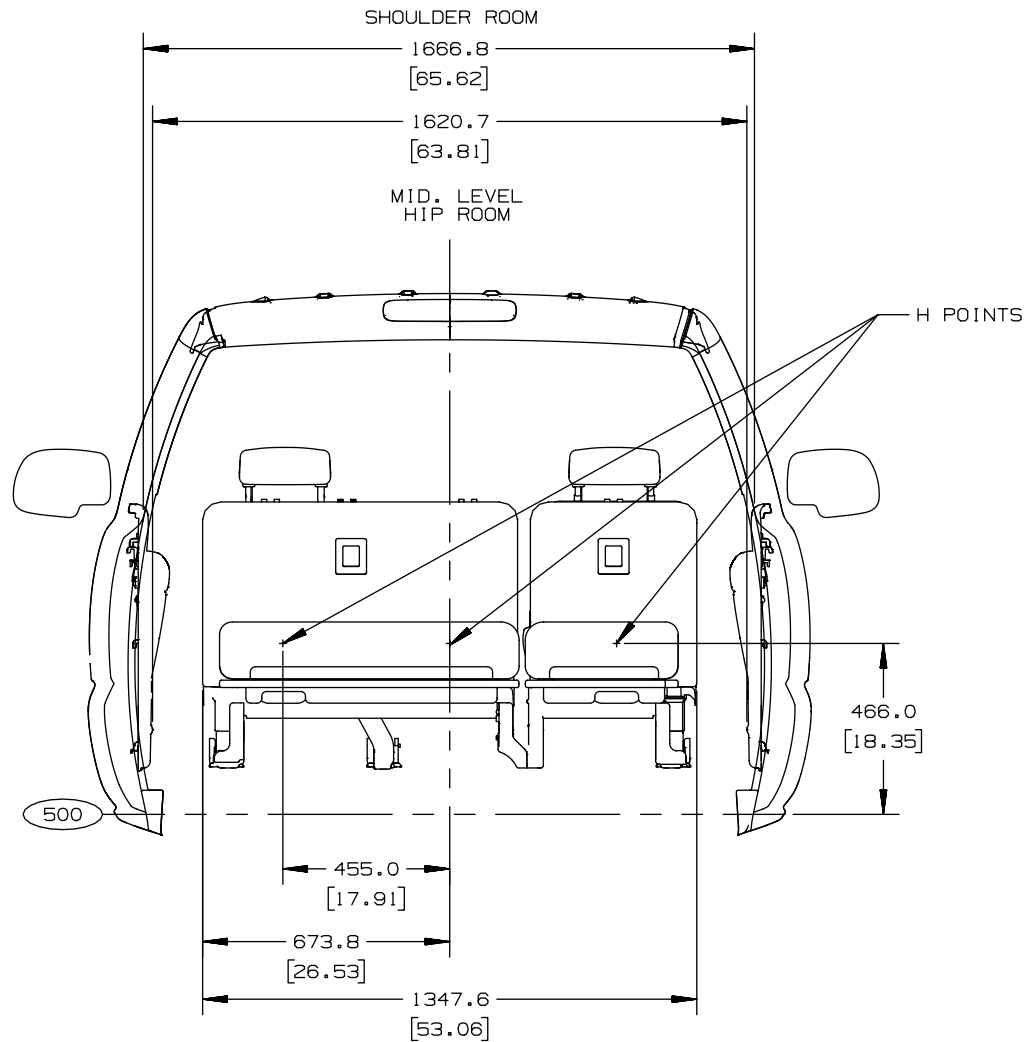

REAR VIEW SHOWING
REAR SEATS FOR CREW CAB

[] = INCHES

TD006068a

C/K 15706 Seating Positions

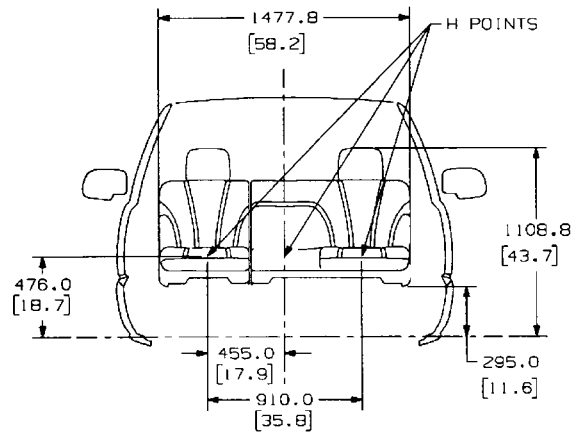

VIEW IN DIRECTION OF ARROW A
2ND SEAT 40/60

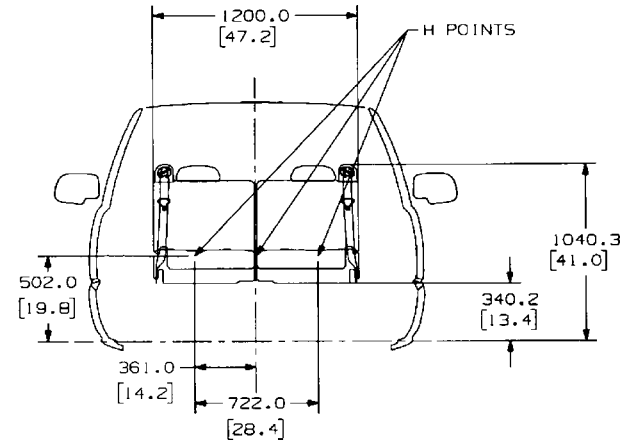

VIEW IN DIRECTION OF ARROW B
3RD SEAT 50/50 SPLIT (OPTIONAL)

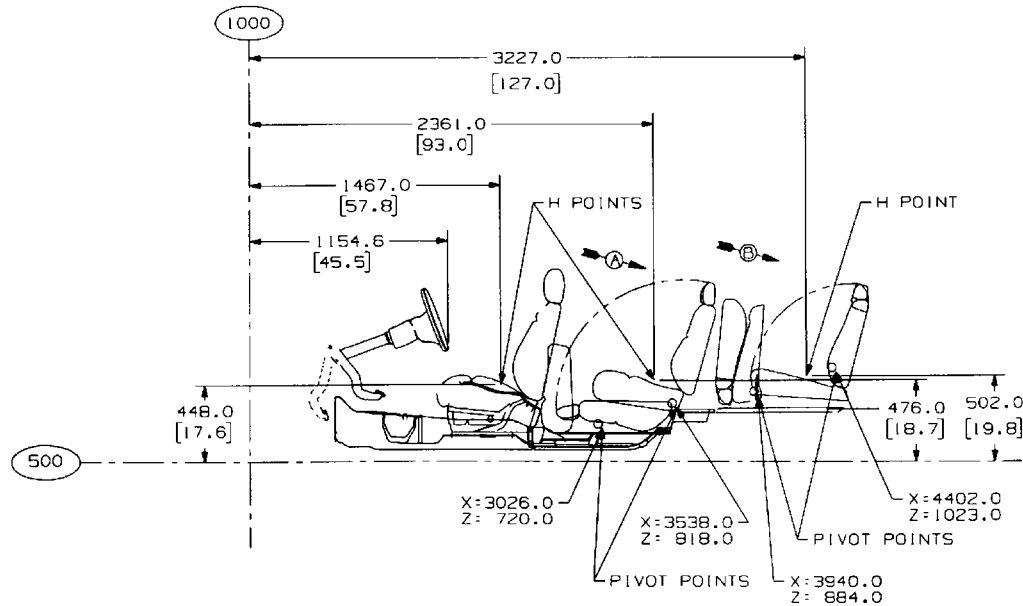

TD005562

C/K (15/25)906 Seating Positions

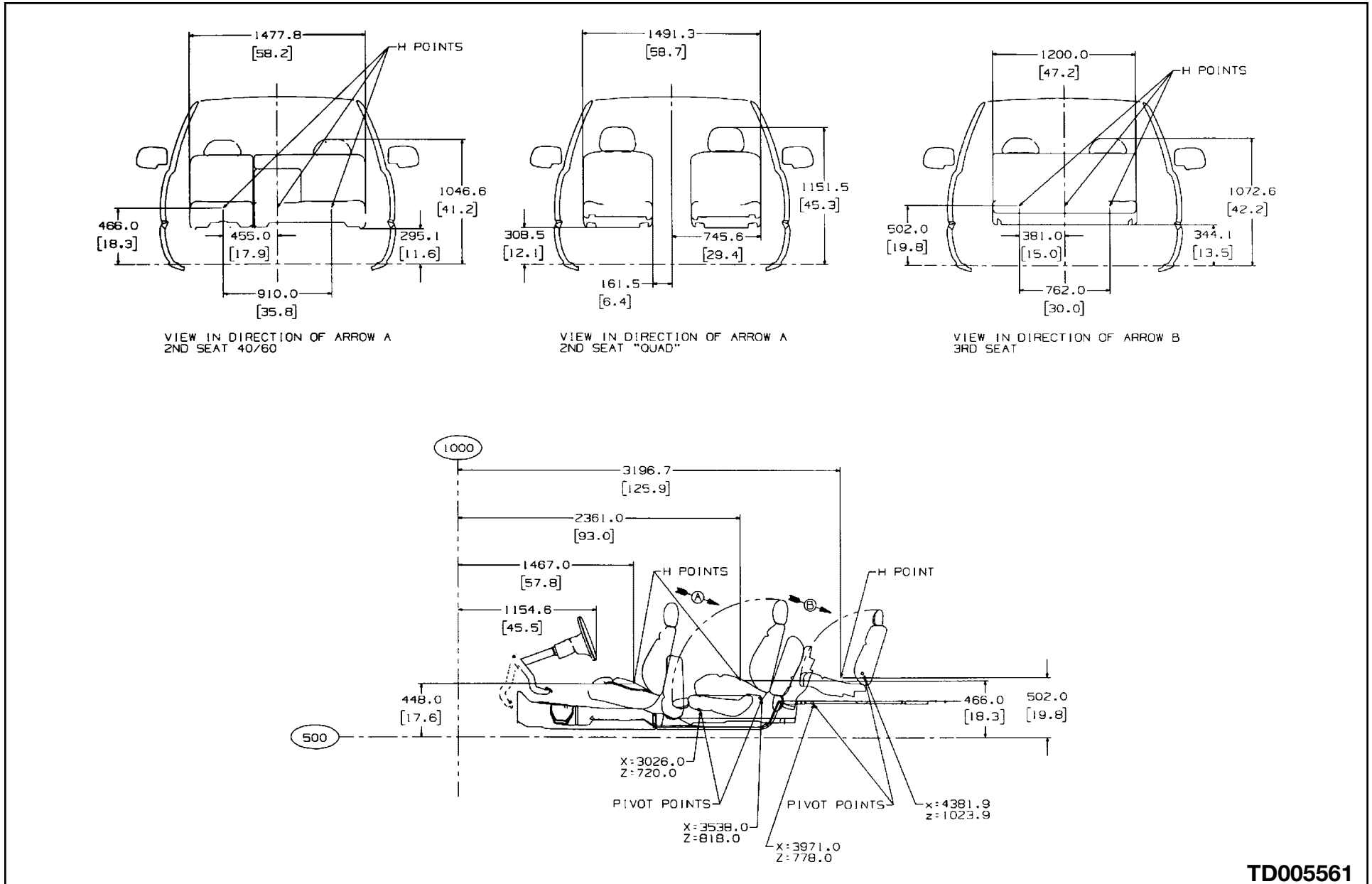

TD005561

C/K (15/25)936 Seating Positions

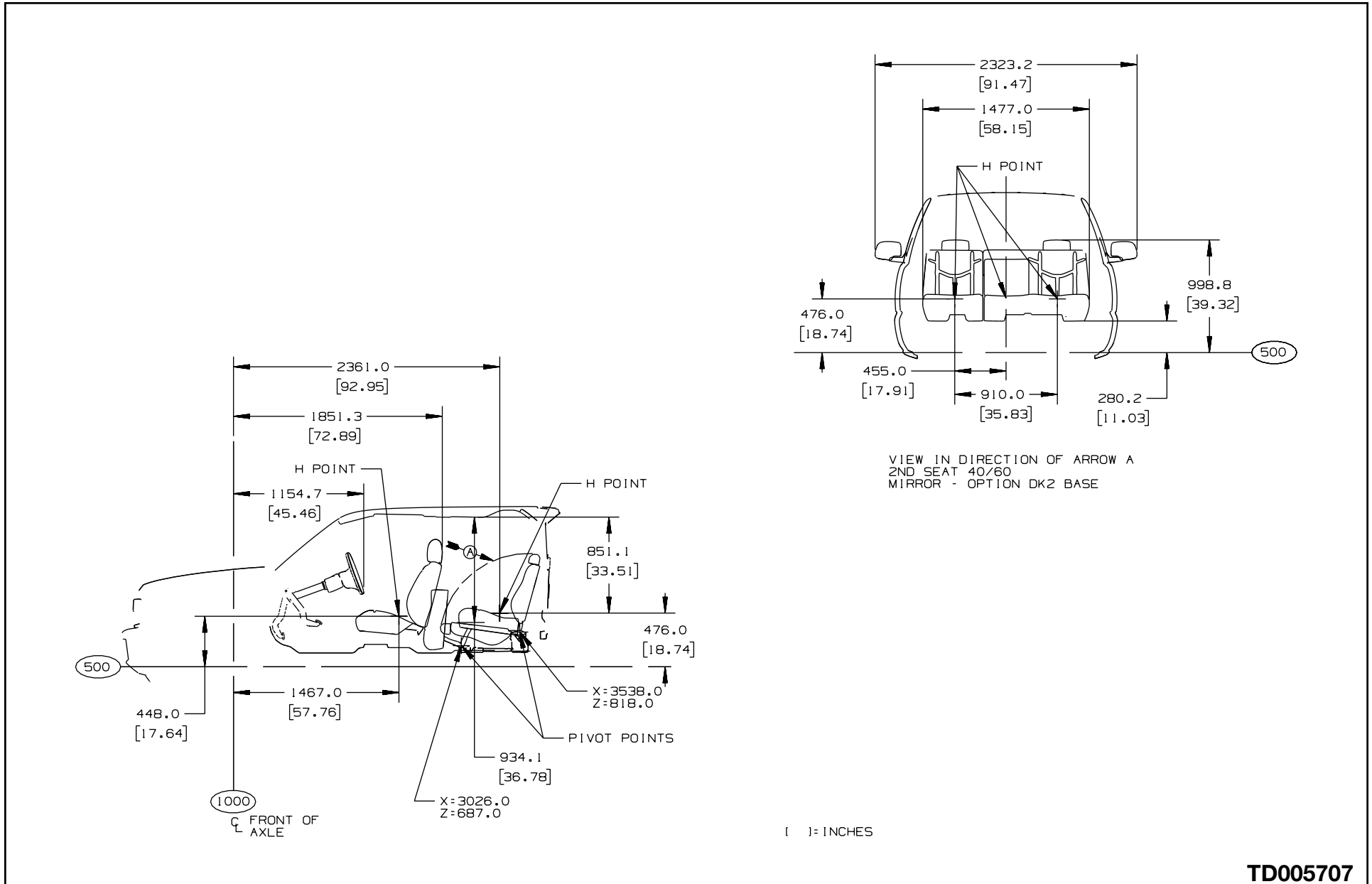

TD005707

C/K (15/25) Regular Cab Chevy Exterior

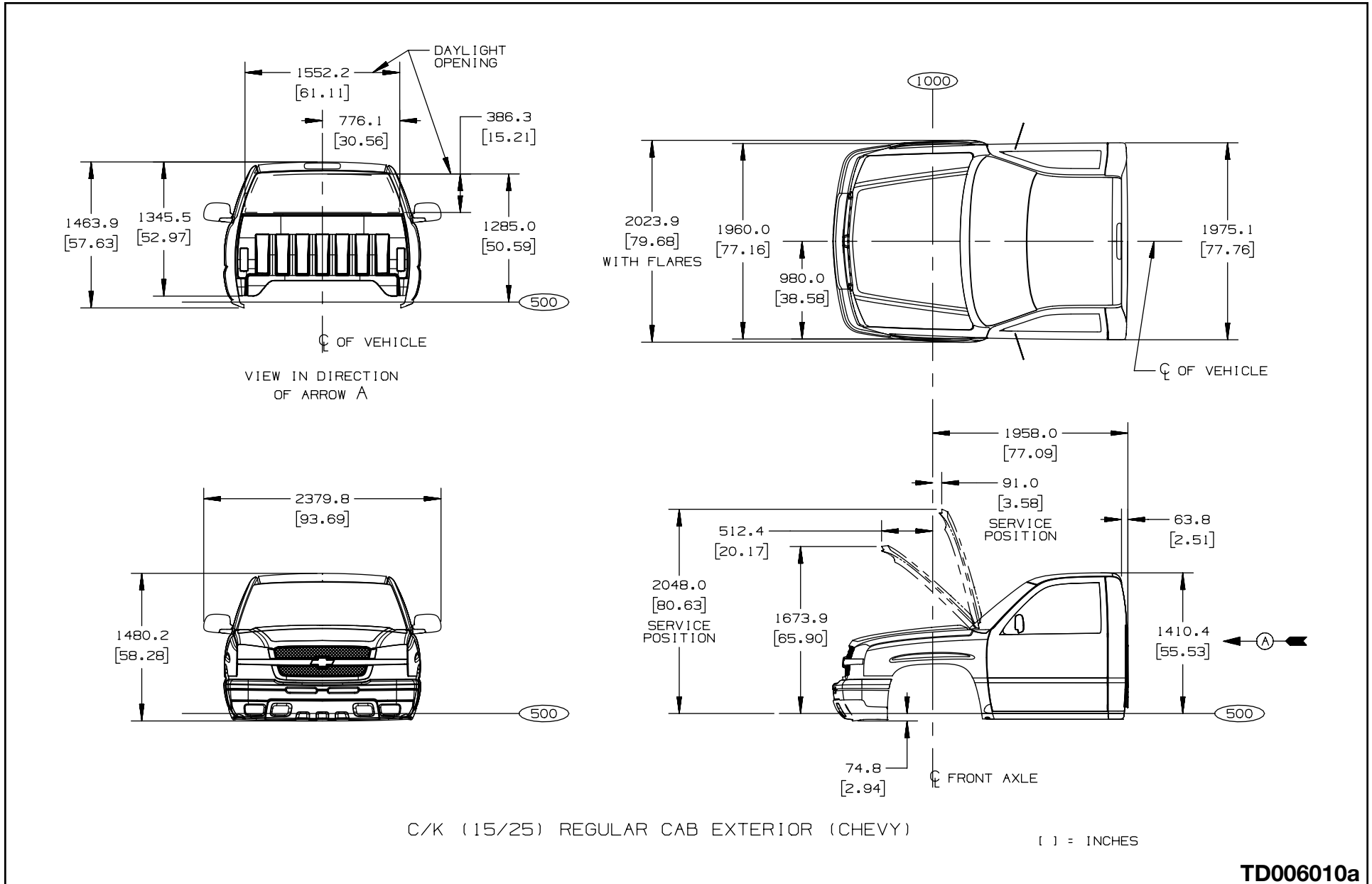

TD006010a

C/K (25HD/35/36) Regular Cab Chevy Exterior

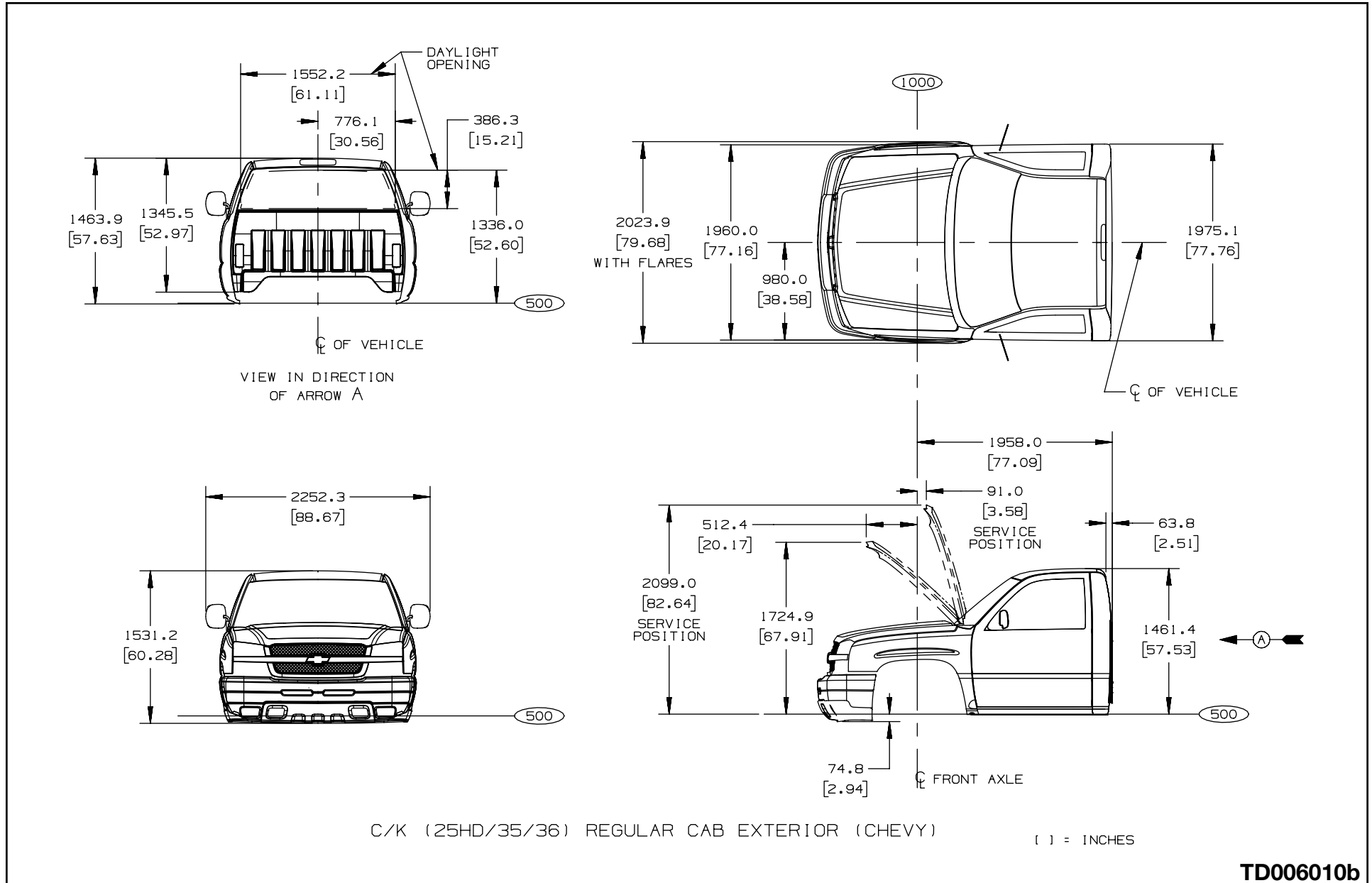

TD006010b

C/K (15/25) Extended Cab Chevy Exterior

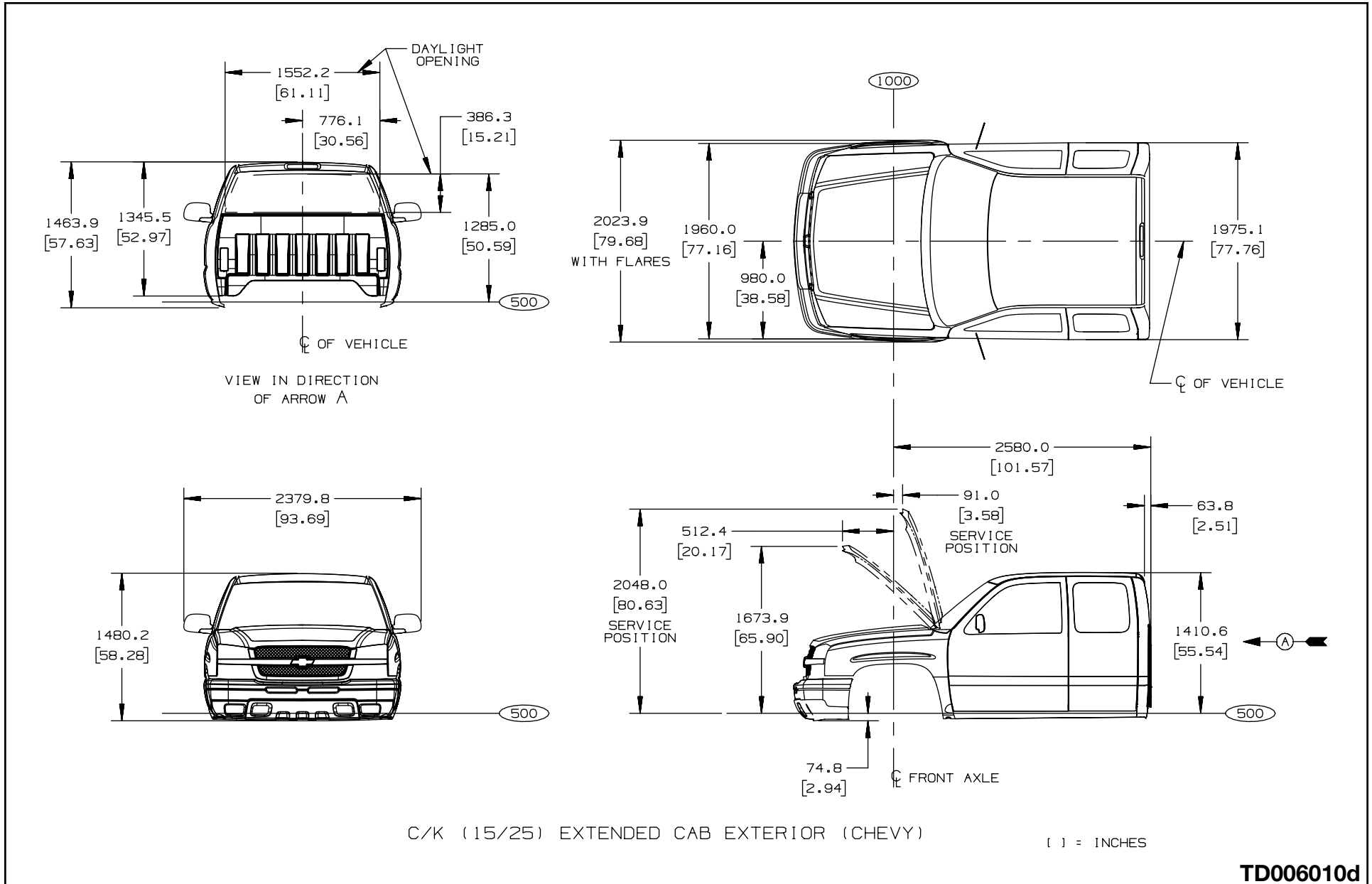

C/K (25HD/35/36) Extended Cab Chevy Exterior

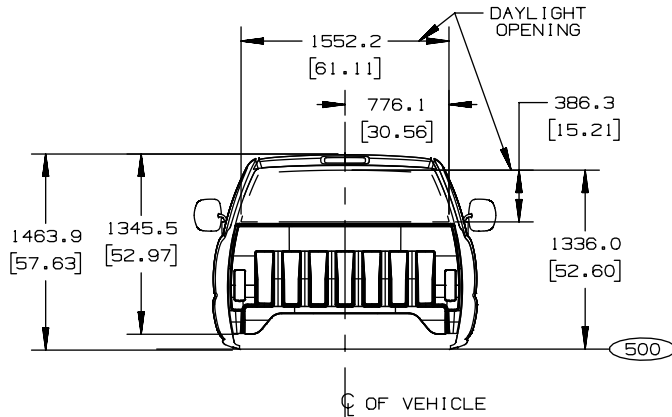

VIEW IN DIRECTION OF ARROW A

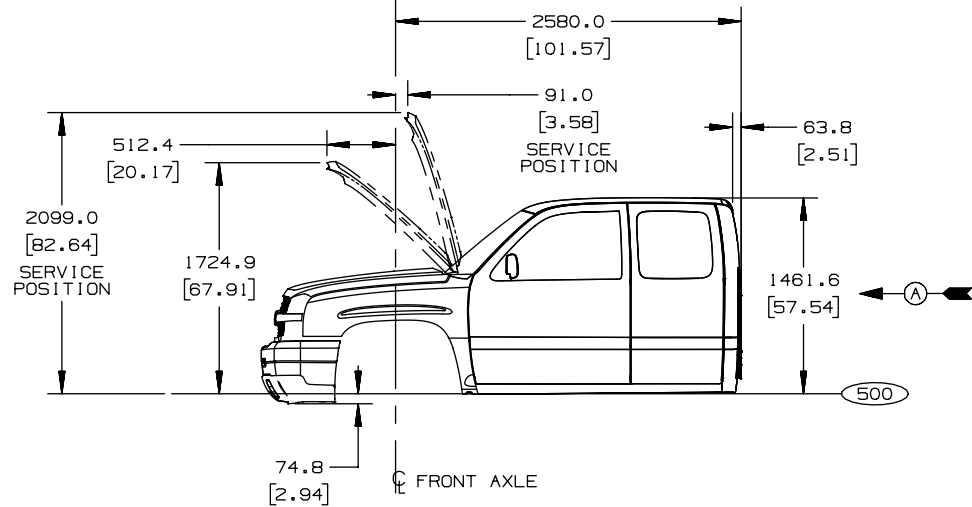
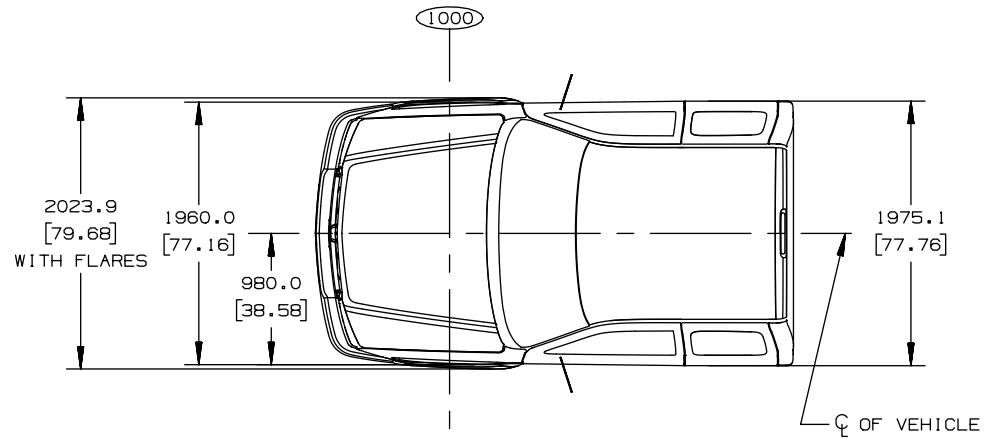
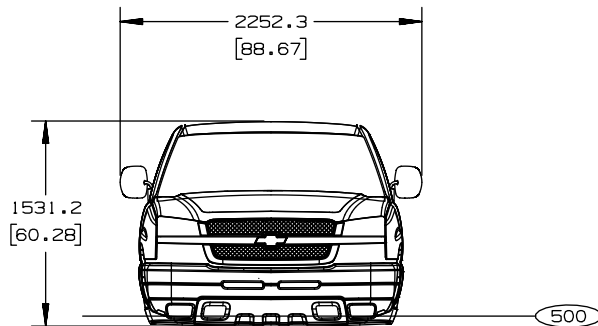

C/K (25HD/35/36) EXTENDED CAB EXTERIOR (CHEVY)

[] = INCHES

C/K (15/25)(43) Crew Cab Chevy Exterior

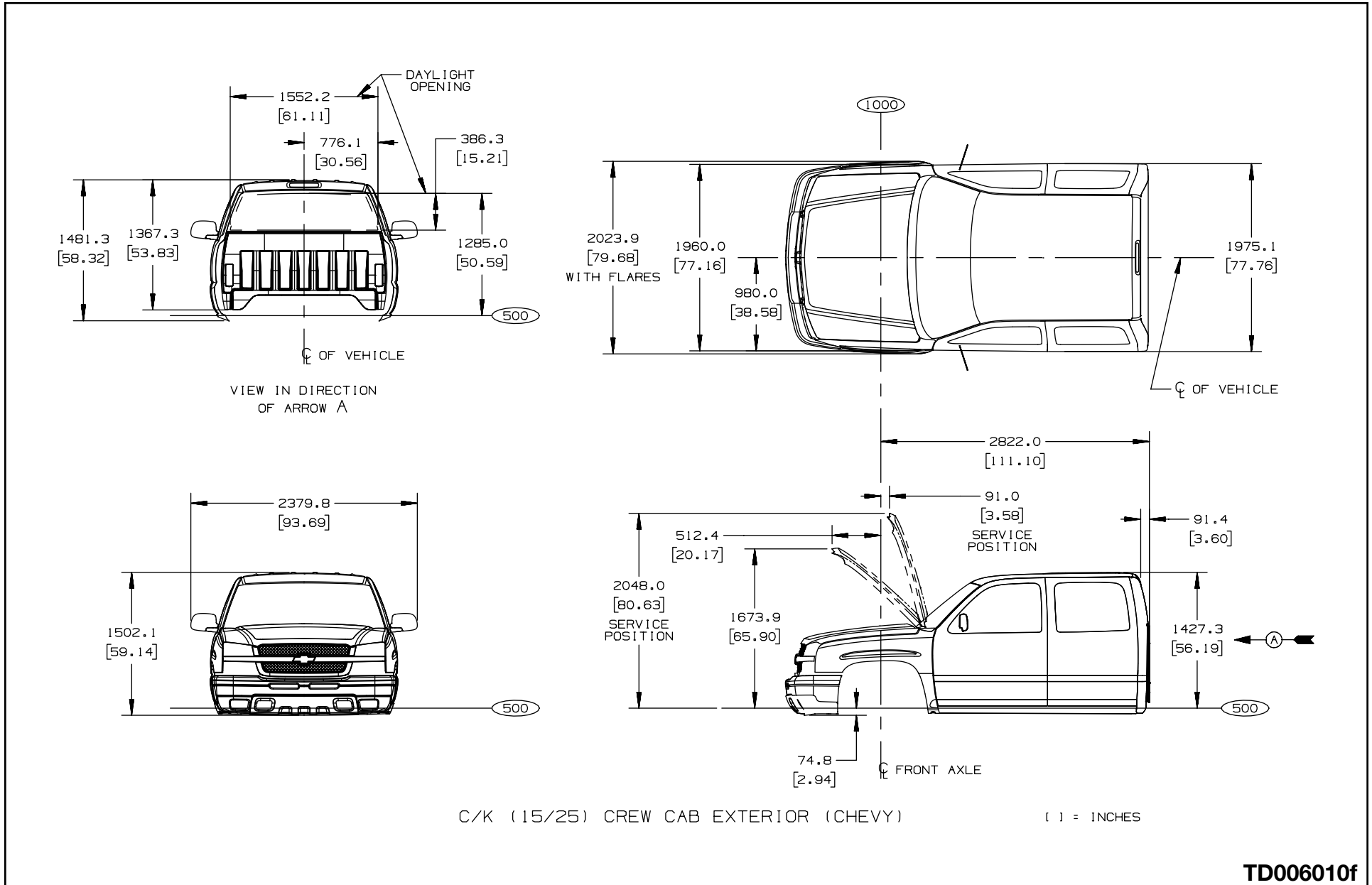

TD006010f

C/K (25HD/35/36)(43) Crew Cab Chevy Exterior

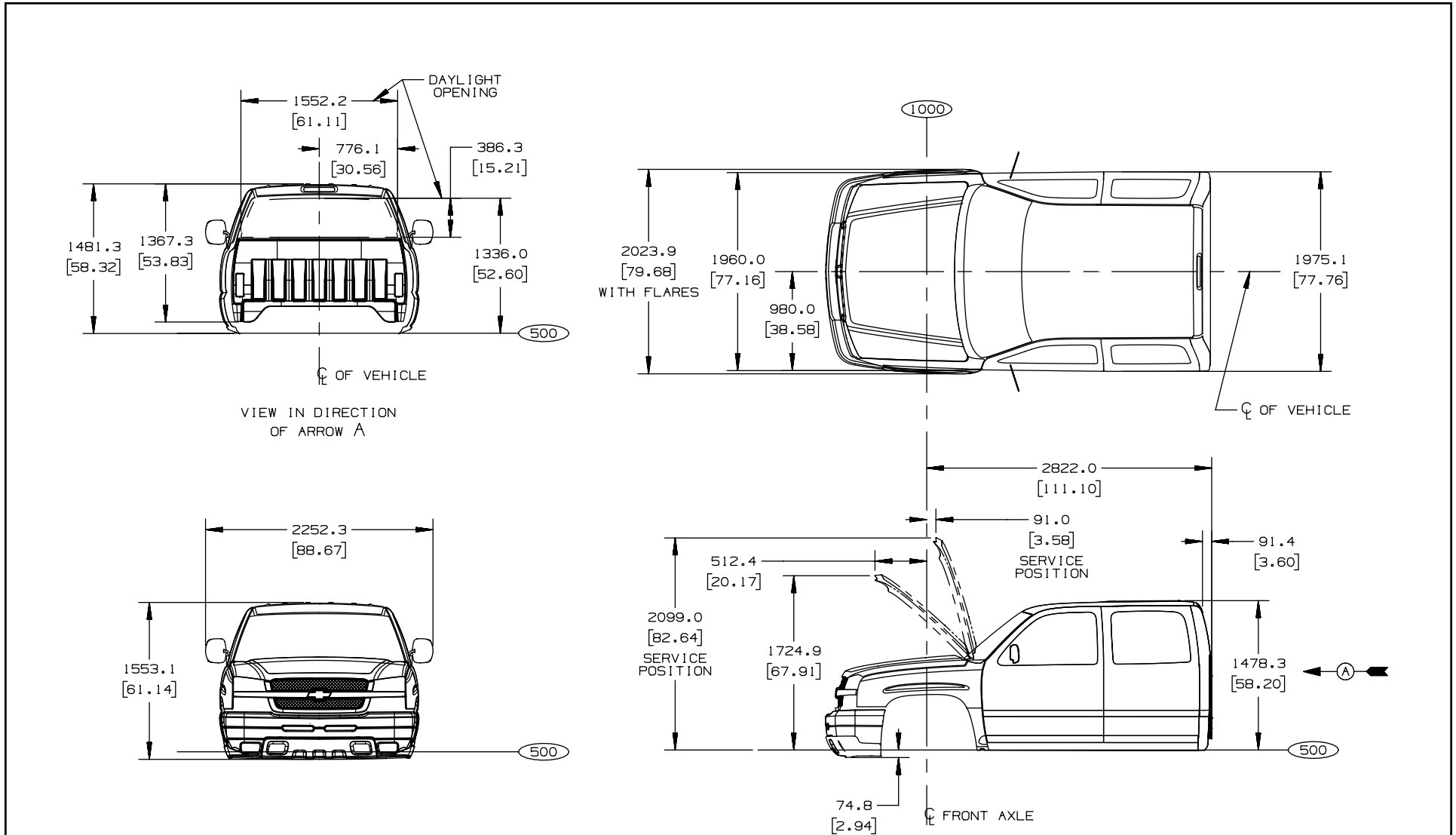

C/K (25HD/35/36) CREW CAB EXTERIOR (CHEVY)

[] = INCHES

TD006010g

2005 & BEYOND C/K FULL SIZE TRUCKS (PICKUPS, UTILITIES AND CHASSIS-CABS)

C/K (15/25/25HD/35/36)(03/43/53/06/36) Door Openings

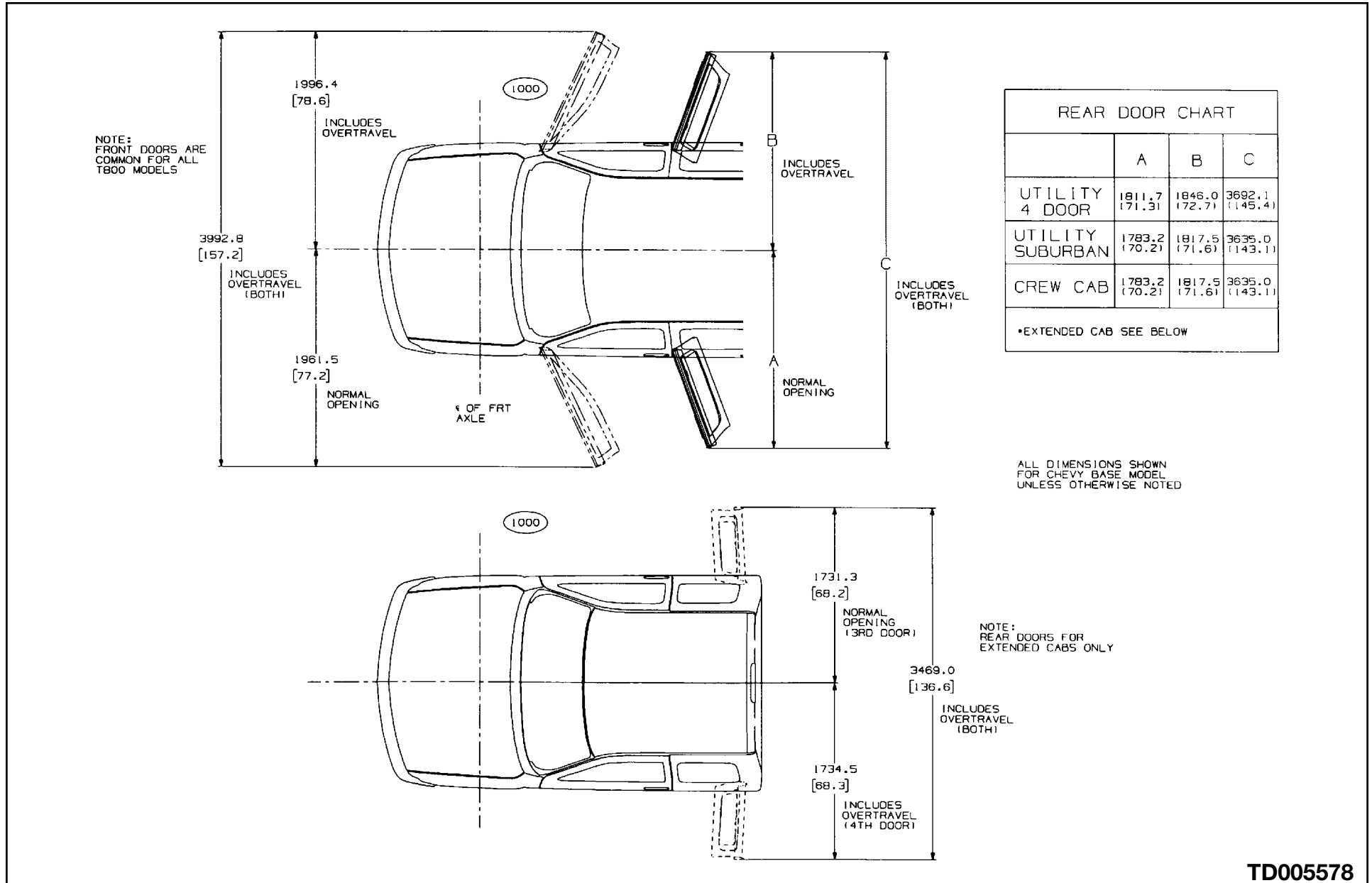

TD005578

C/K (15/25)(7/9)06 Rear Door Openings

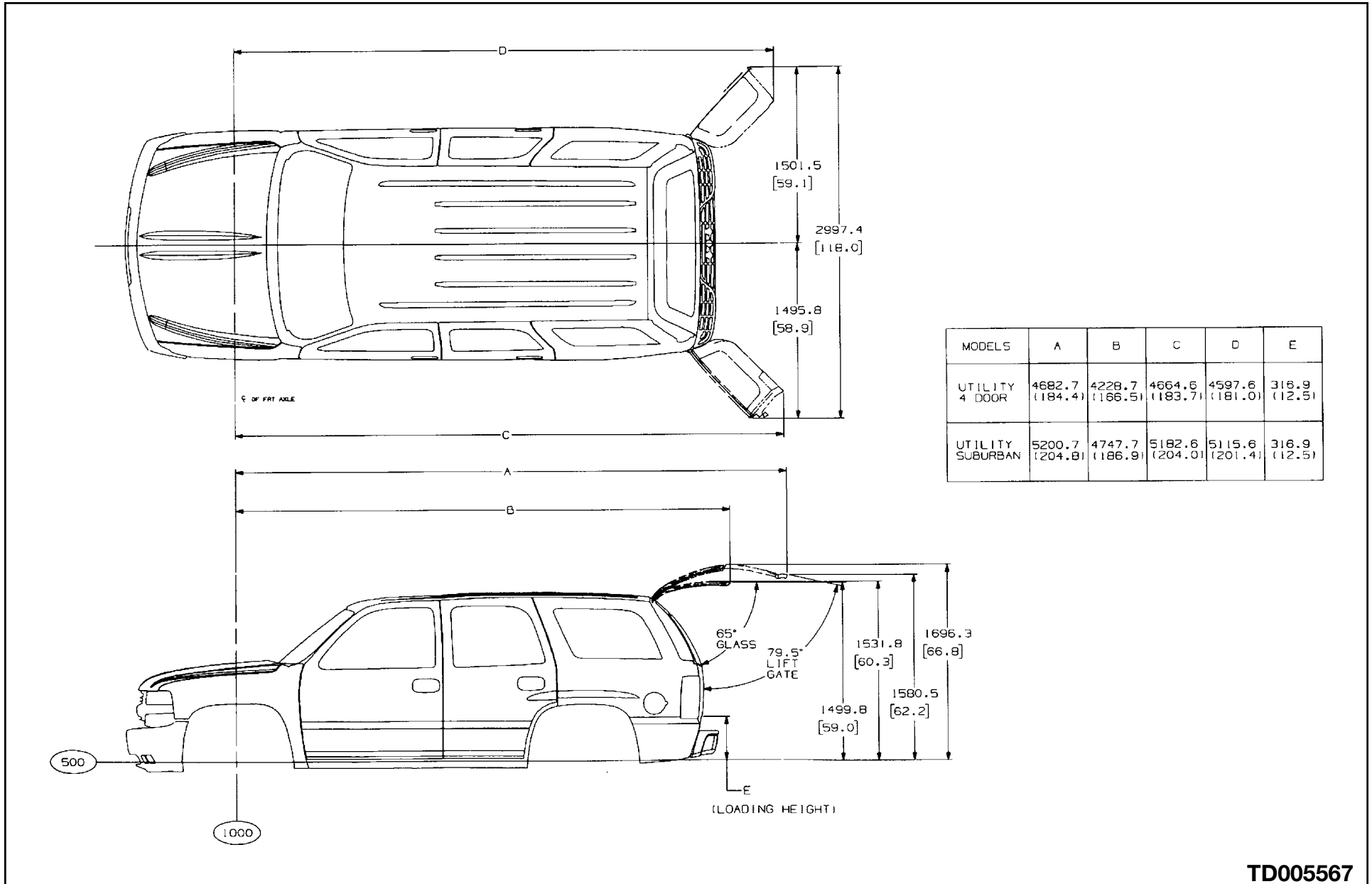

TD005567

C/K (157/159/259)(06) Front End Sheet Metal – Utilities

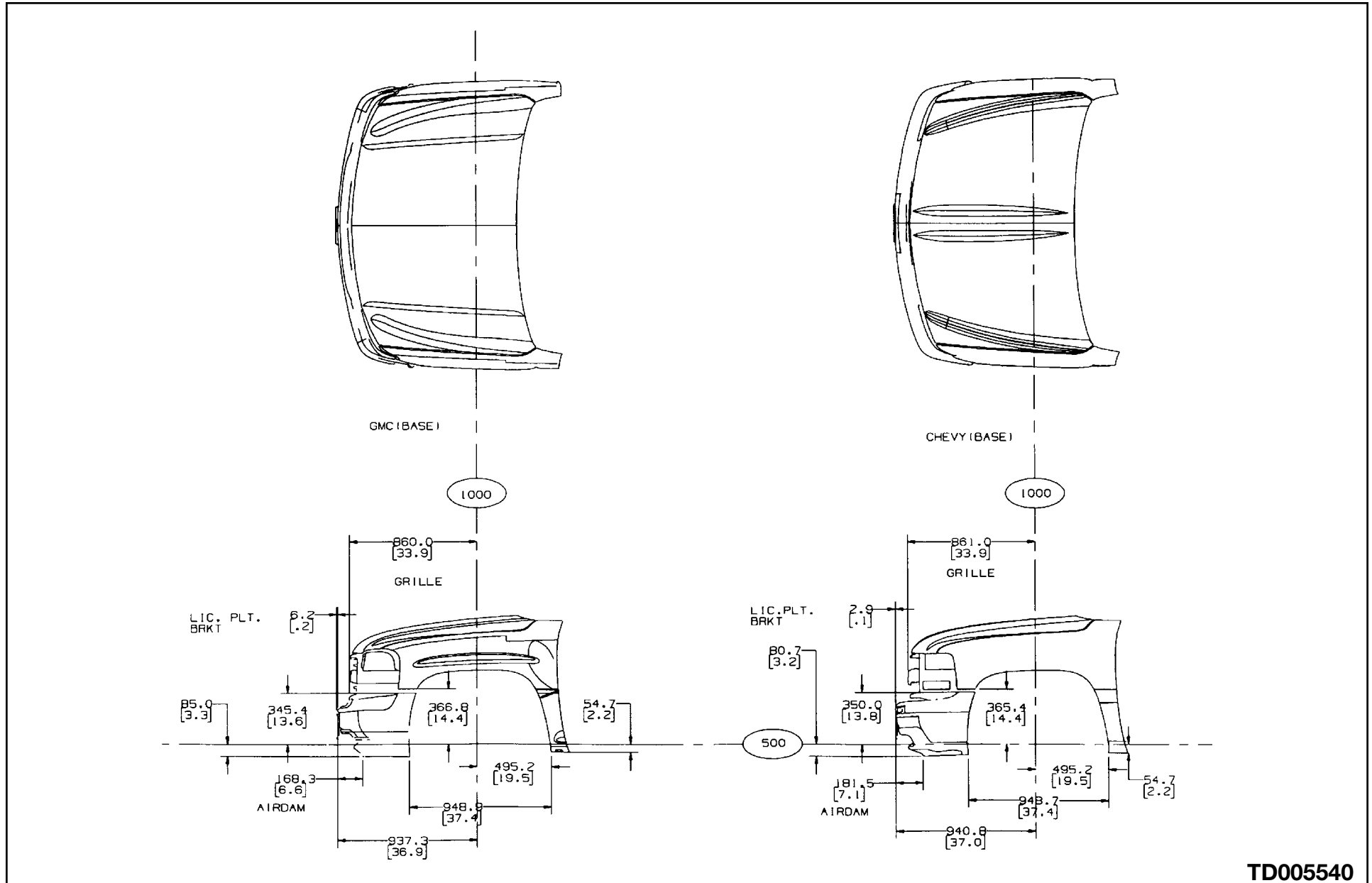

TD005540

C/K (15/25) Front End Sheet Metal – Pickups and Chassis-Cab

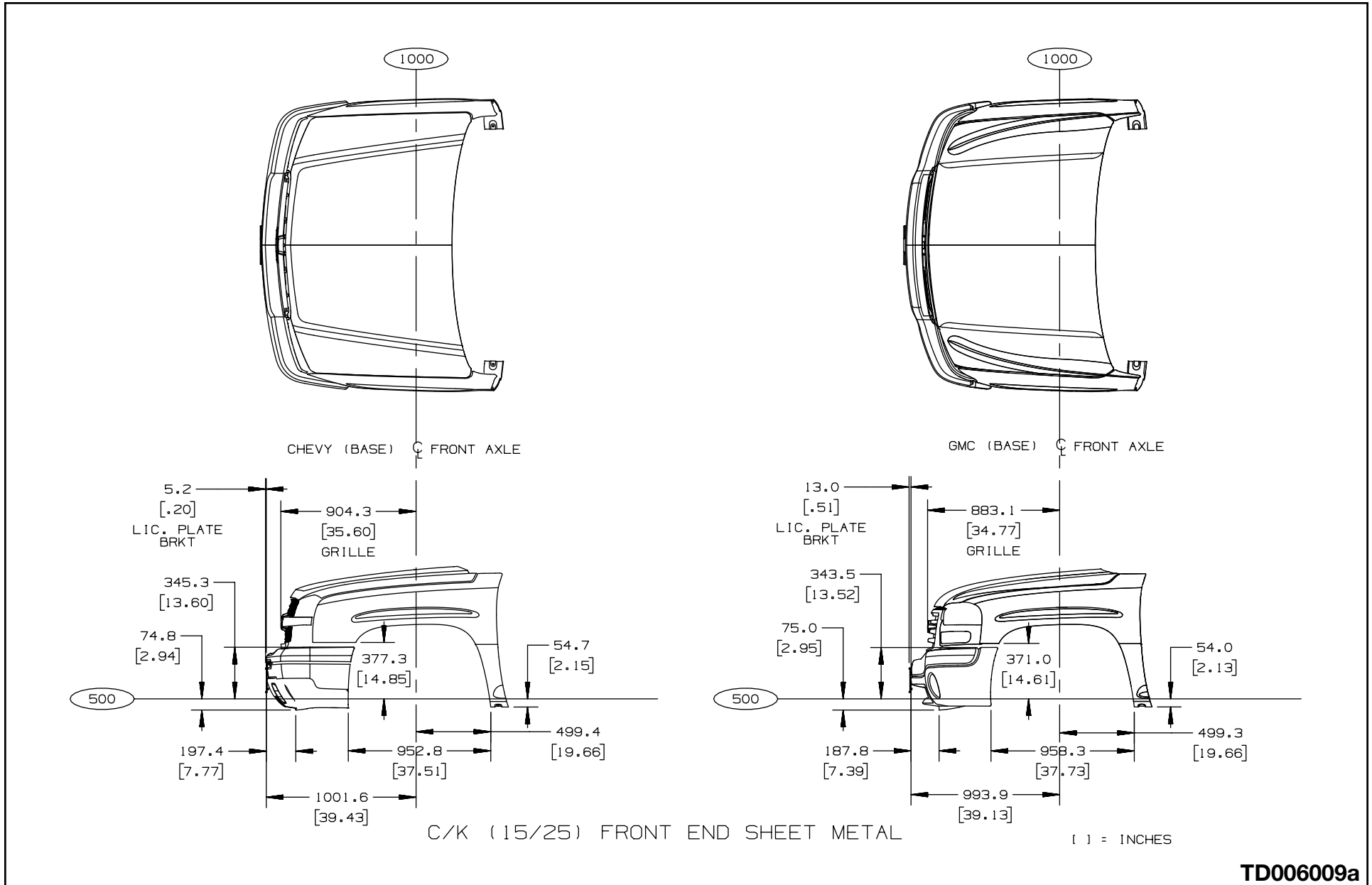

TD006009a

2005 & BEYOND C/K FULL SIZE TRUCKS (PICKUPS, UTILITIES AND CHASSIS-CABS)

C/K (25HD/35/36) Front End Sheet Metal – Pickups and Chassis-Cab

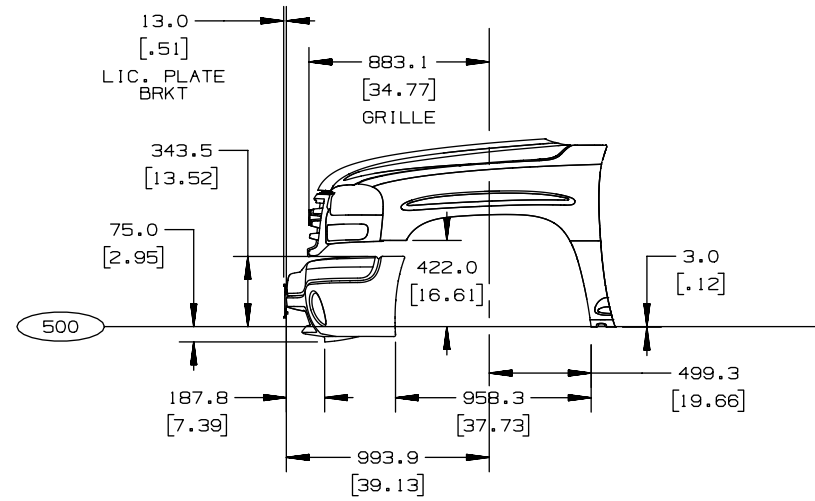
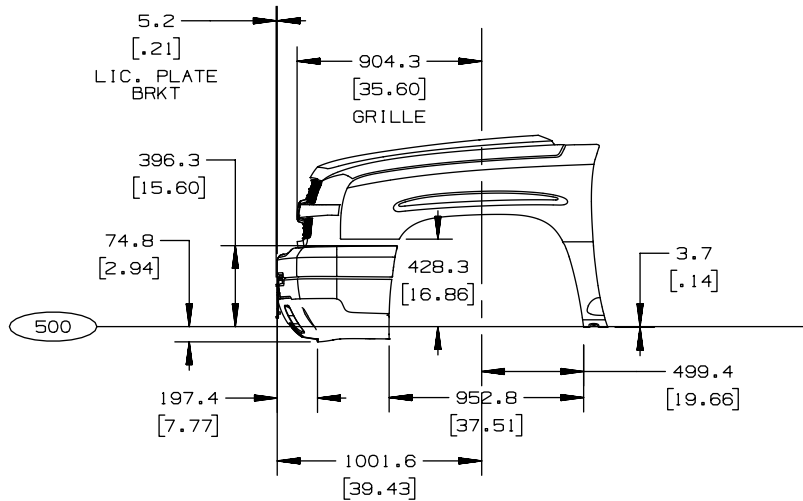
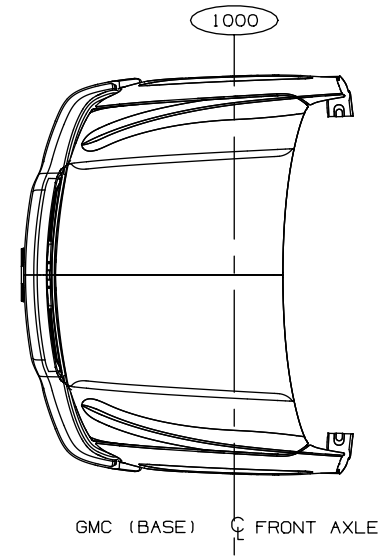
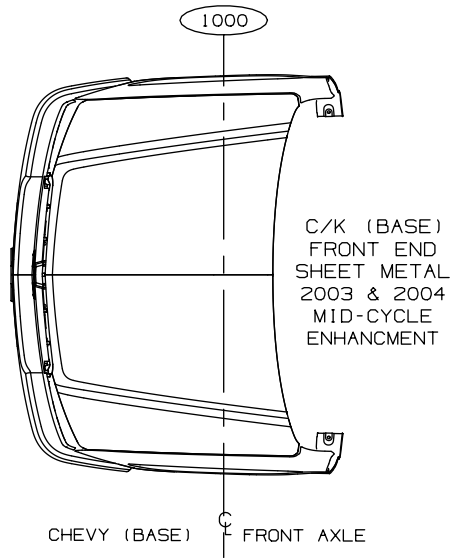

C/K (25HD/35/36) FRONT END SHEET METAL

[] = INCHES

TD006009b

2005 and Beyond MCE Hood and Grille Chevrolet 25HD/35/36

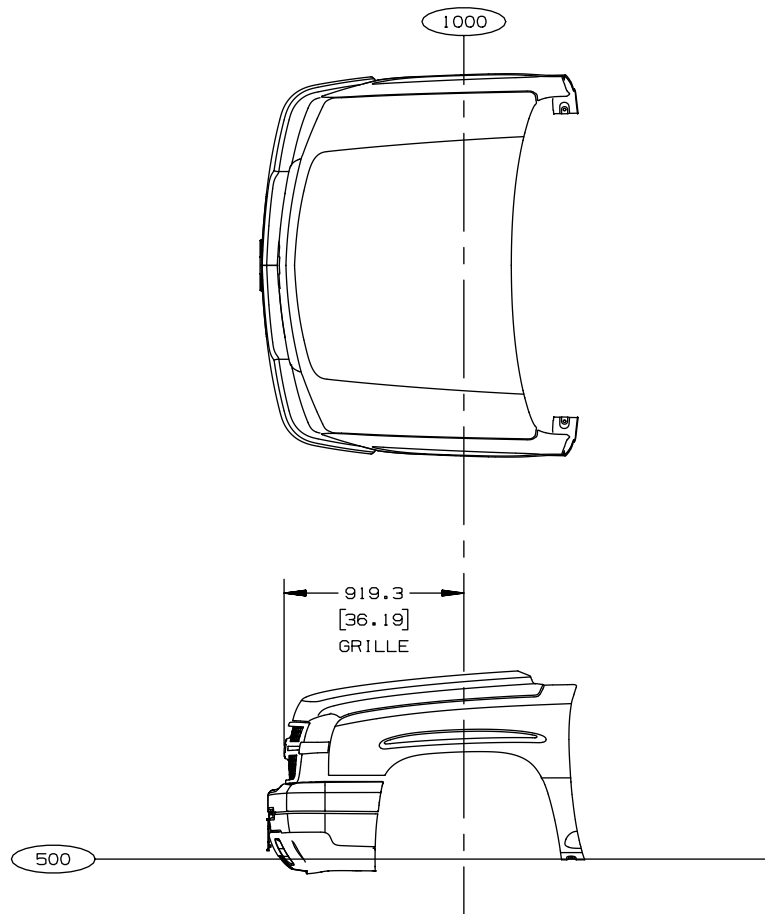

HOOD & GRILLE
C/K (25HD/35/36) (03/43/53), 2005
X88 MID-CYCLE ENHANCMENT

19JL04NI

[] = INCHES

TD006009c

Hood Swing 2005 and Beyond Chevrolet 25HD/35/36

HOOD SWINGS (CHEVY)
2005, MID-CYCLE ENHANCEMENT
C/K (25HD/35/36) (03/43/53)

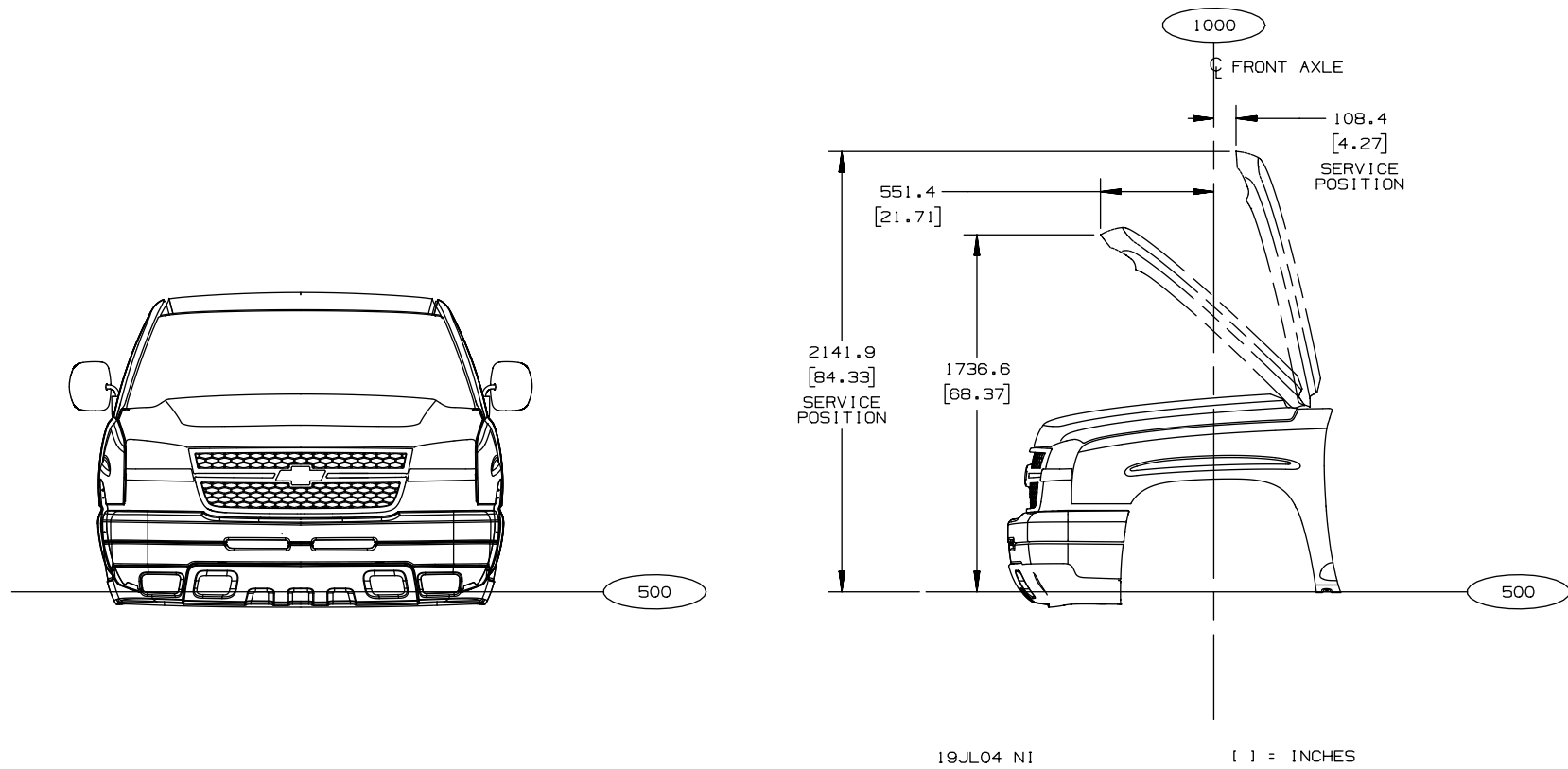

TD006010i

C/K (15/25)936 Front End Sheet Metal

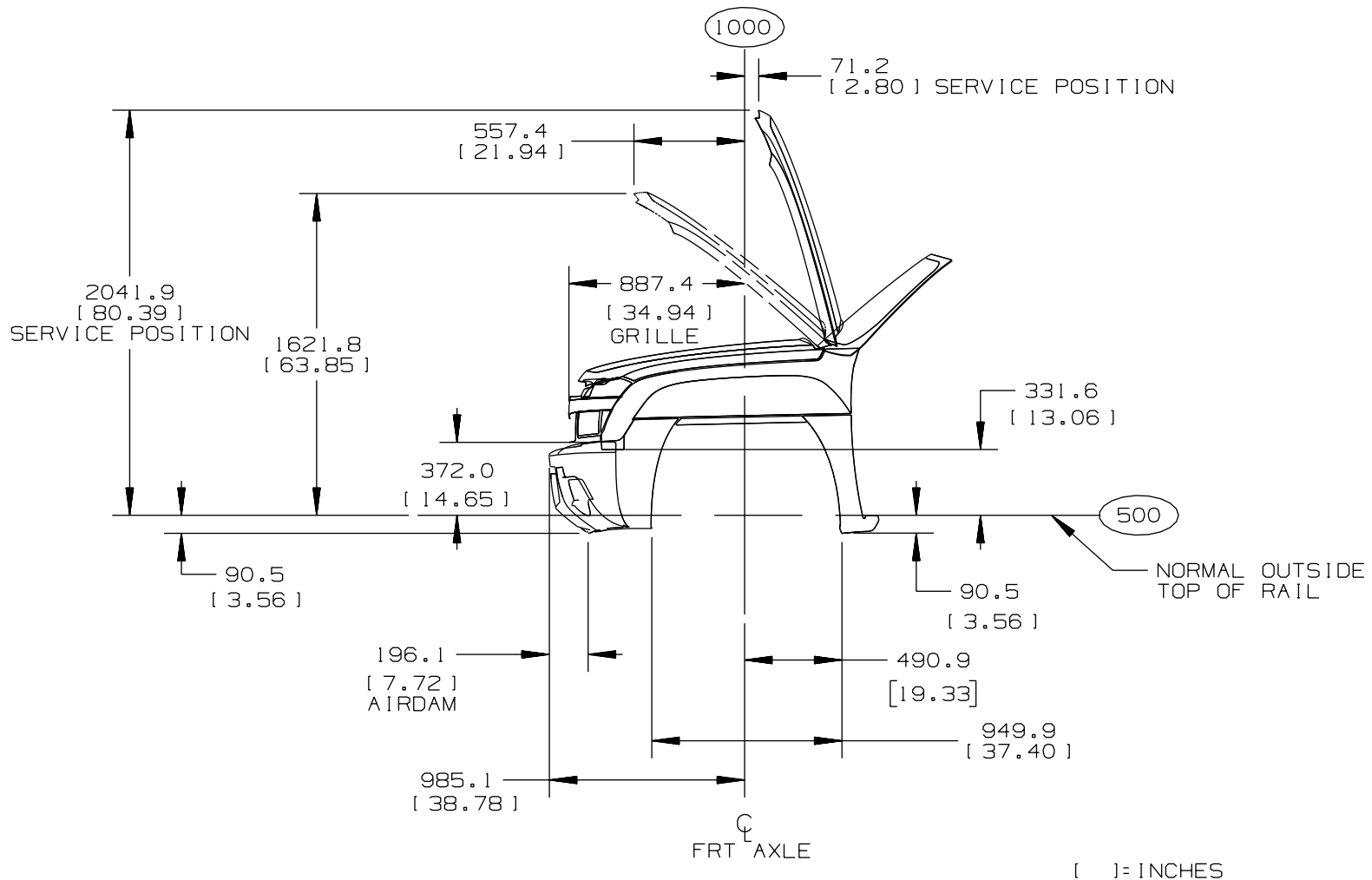

TD005705

C/K (15/25)(03/53/06) Outside, Mirror Options

C/K (15/25)(03/53/43/06) OUTSIDE MIRROR OPTIONS

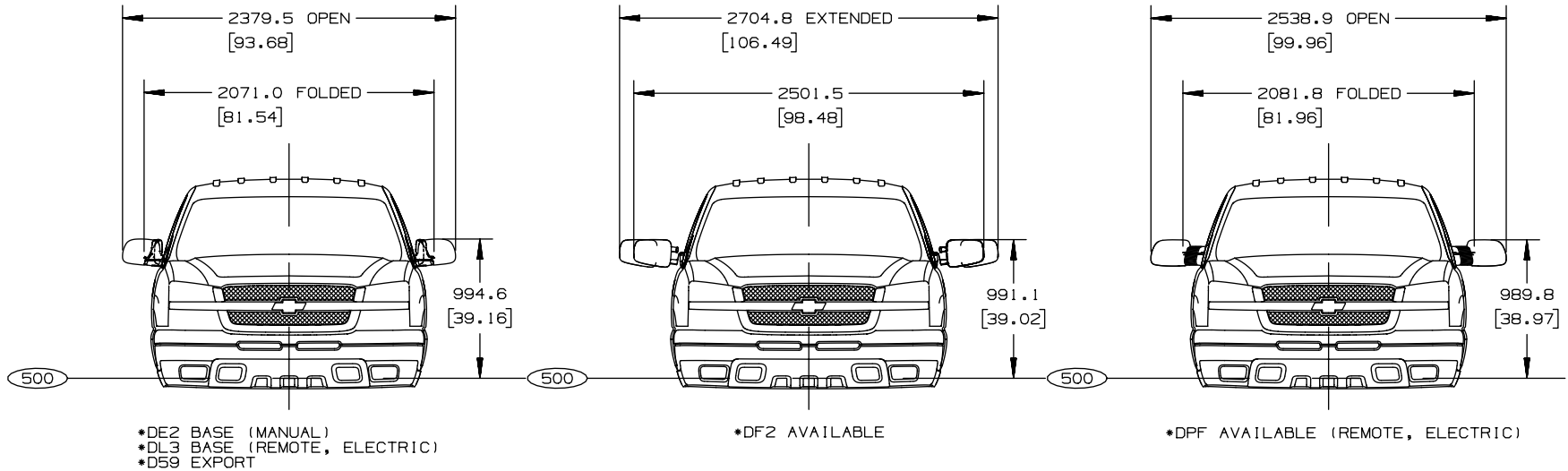

FOR: GMT 800, C/K (15/25)(03/53/43/06), 2003

ALL DIMENSIONS SHOWN FOR CHEVY BASE MODEL UNLESS OTHERWISE NOTED

[] = INCHES

C/K (25HD/35/36) Outside, Mirror Options

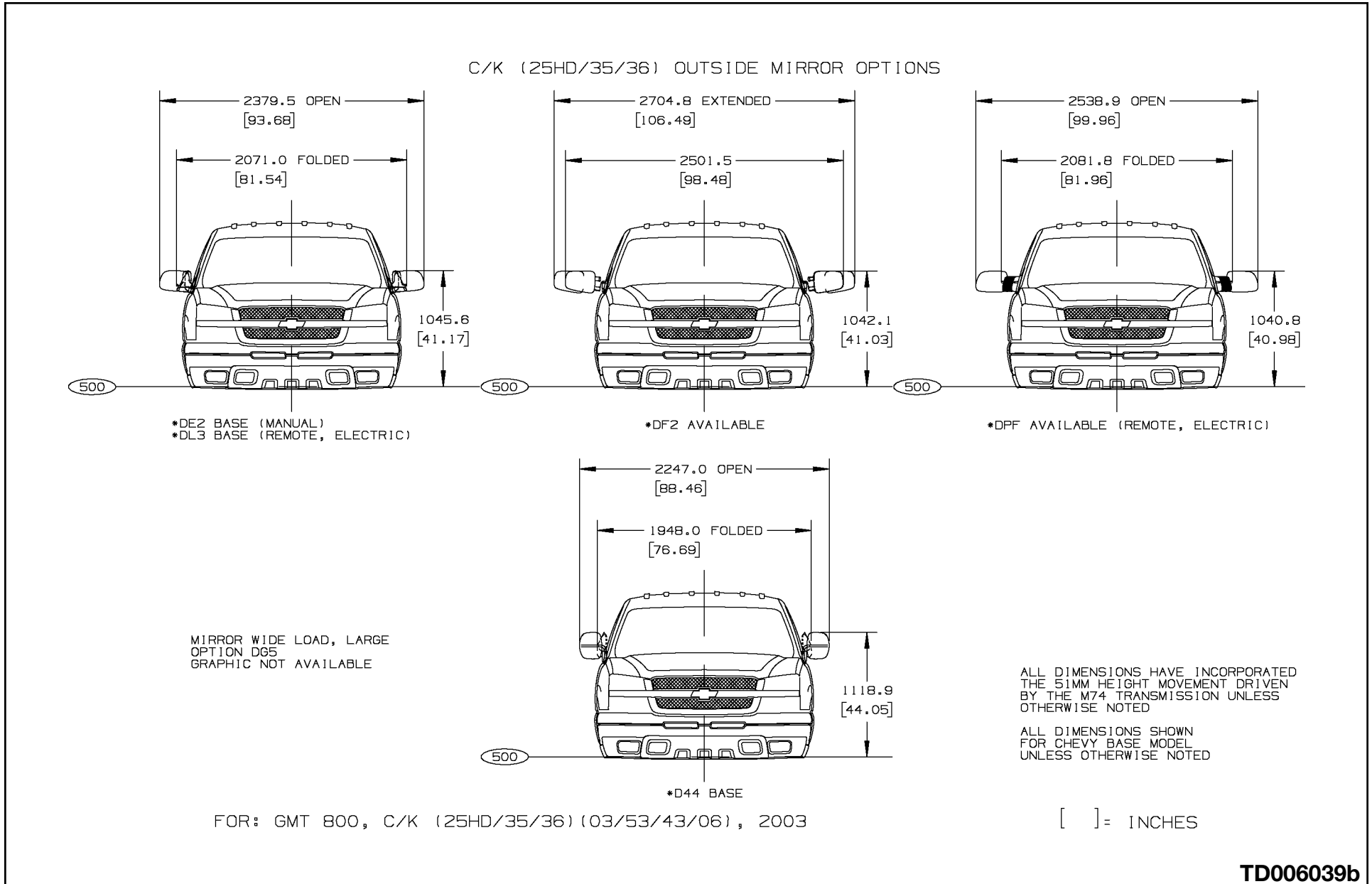

C/K (15/25)936 Outside, Mirror Options

C/K (15/25)936 OUTSIDE MIRROR OPTIONS

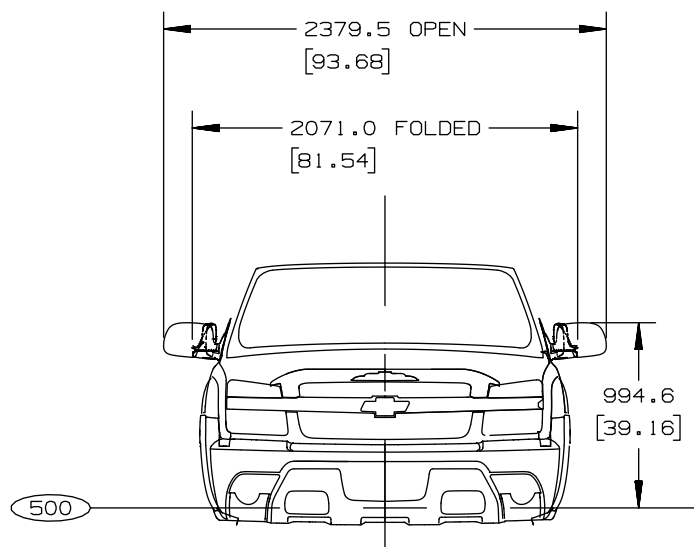

*DE2 BASE (MANUAL)
*DL3 BASE (REMOTE, ELECTRIC)

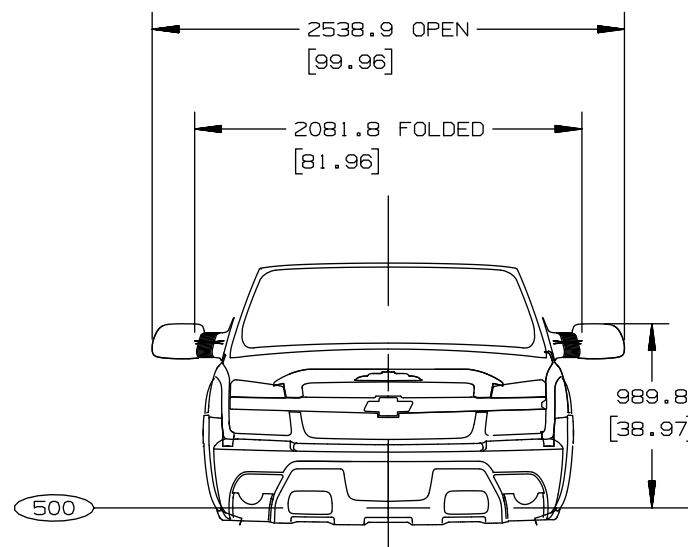

*DPF AVAILABLE (REMOTE, ELECTRIC)

ALL DIMENSIONS SHOWN
FOR CHEVY BASE MODEL
UNLESS OTHERWISE NOTED

FOR: GMT800, C/K (15/25)936, 2003

[] = INCHES

TD006039c

C/K (15/25)(03/53) Back of Cab Profile Nominal

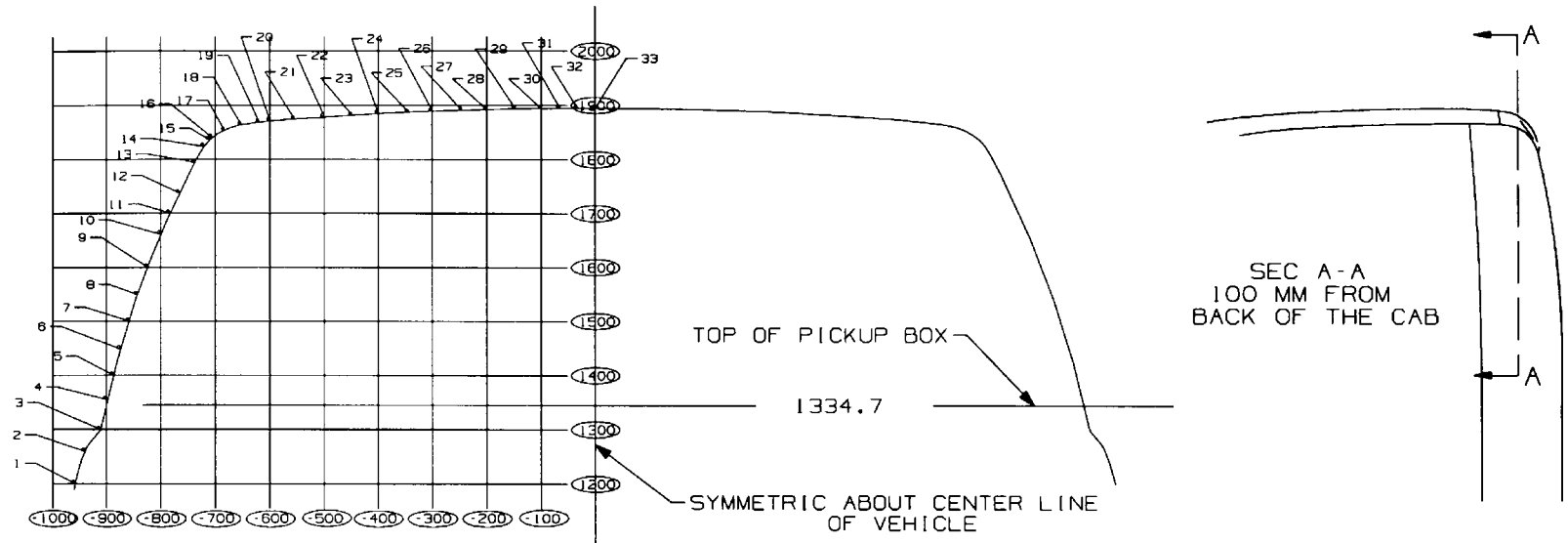

DRIVER SIDE COORDINATES

PT #	WIDTH	HEIGHT
1	-958.74	1200.00
2	-938.08	1264.98
3	-911.62	1300.00
4	-900.00	1350.59
5	-888.05	1400.00
6	-873.75	1452.70
7	-859.42	1500.00
8	-845.94	1540.87
9	-824.57	1600.00
10	-800.00	1661.35
11	-783.23	1700.00

PT #	WIDTH	HEIGHT
12	-751.80	1766.91
13	-734.80	1800.00
14	-724.51	1818.00
15	-714.22	1831.97
16	-700.00	1844.60
17	-677.79	1855.90
18	-655.00	1863.47
19	-625.19	1867.85
20	-600.00	1870.63
21	-550.40	1874.64
22	-500.00	1878.10

PT #	WIDTH	HEIGHT
23	-440.45	1881.76
24	-400.00	1884.02
25	-352.43	1886.44
26	-300.00	1888.82
27	-247.74	1890.81
28	-200.00	1892.29
29	-143.45	1893.59
30	-100.00	1894.30
31	-65.20	1894.69
32	-26.00	1894.94
33	000.00	1895.00

TD005534

C/K (25HD/35/36) Back of Cab Profile Nominal

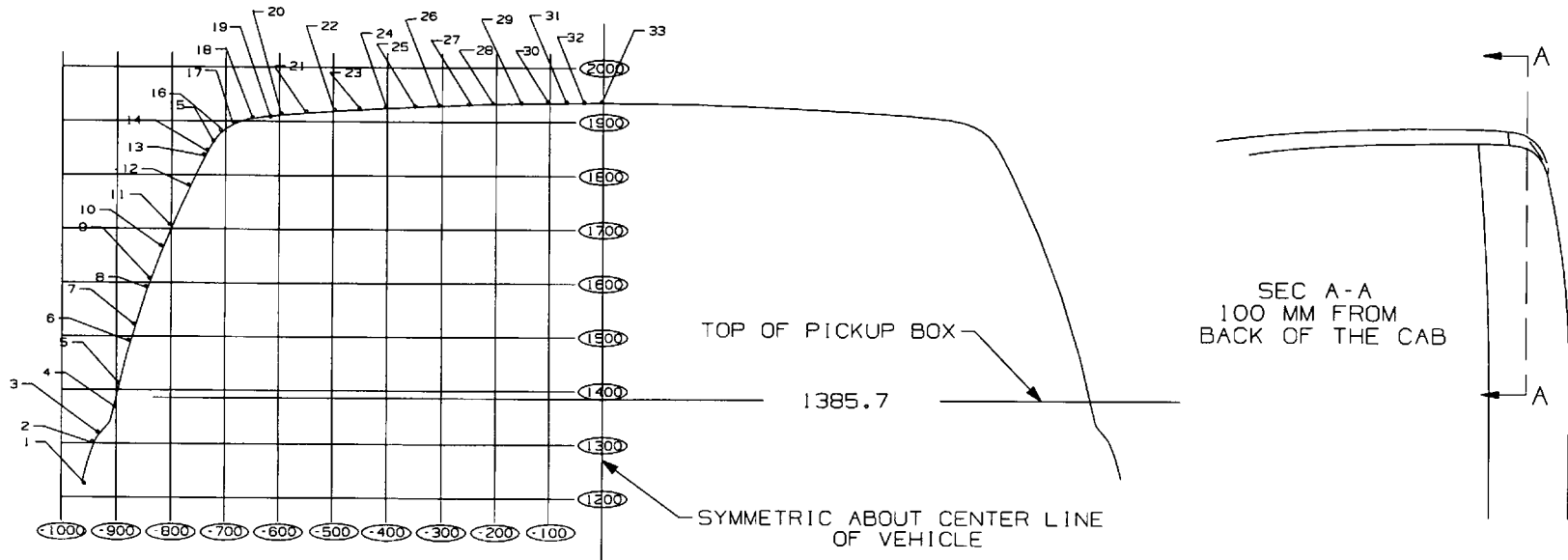

DRIVER SIDE COORDINATES

PT #	WIDTH	HEIGHT
1	-958.74	1251.00
2	-938.08	1315.98
3	-911.62	1351.00
4	-900.00	1401.59
5	-888.05	1451.00
6	-873.75	1503.70
7	-859.42	1551.00
8	-845.94	1591.87
9	-824.57	1651.00
10	-800.00	1712.35
11	-783.23	1751.00

PT #	WIDTH	HEIGHT
12	-751.80	1817.91
13	-734.80	1851.00
14	-724.51	1869.00
15	-714.22	1864.97
16	-700.00	1895.60
17	-677.79	1906.90
18	-655.00	1914.47
19	-625.19	1918.85
20	-600.00	1921.63
21	-550.40	1925.64
22	-500.00	1929.10

PT #	WIDTH	HEIGHT
23	-440.45	1932.76
24	-400.00	1935.02
25	-352.43	1937.44
26	-300.00	1939.82
27	-247.74	1941.81
28	-200.00	1943.29
29	-143.45	1944.59
30	-100.00	1945.30
31	-65.20	1945.69
32	-26.00	1945.94
33	000.00	1946.00

C/K (15/25)(706/906) Hood Profile – Chevy, Tahoe and Suburban

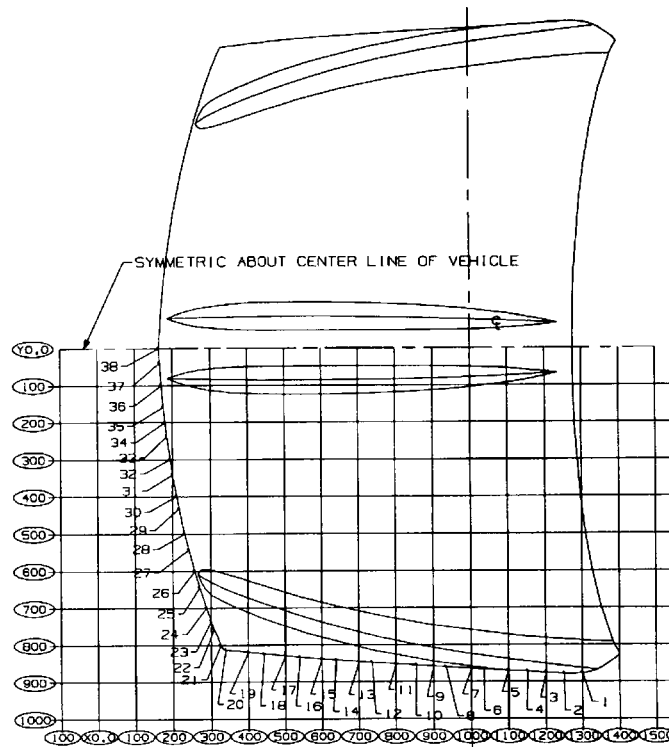

PT #	LENGTH	WIDTH
1	1300.0	-877.8
2	1249.8	-878.8
3	1200.0	-876.2
4	1150.9	-873.2
5	1100.0	-820.1
6	1035.0	-866.4
7	1000.0	-864.2
8	933.5	-860.2
9	900.0	-858.1
10	853.6	-855.3
11	800.0	-851.9
12	736.2	-847.8
13	700.0	-845.4
14	637.8	-841.0
15	600.0	-838.1
16	539.9	-838.1
17	500.0	-829.6
18	442.9	-824.0
19	400.0	-819.4
20	339.2	-812.7
21	326.4	-800.0
22	308.6	-757.2
23	300.0	-734.2
24	287.9	-700.0
25	270.0	-644.6
26	257.0	-600.0
27	242.0	-543.7
28	231.4	-500.0
29	216.9	-433.0
30	210.5	-400.0
31	200.0	-341.1
32	193.5	-300.0
33	184.7	-237.2
34	180.2	-200.0
35	175.8	158.3
36	170.6	-100.0
37	166.6	-39.6
38	164.6	00.0

DRIVER SIDE COORDINATES

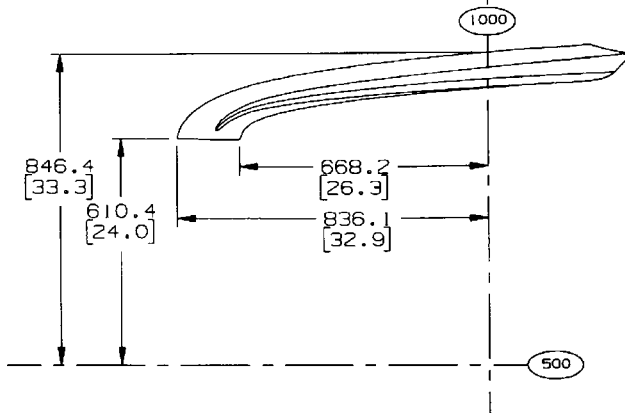

2005 & BEYOND C/K FULL SIZE TRUCKS (PICKUPS, UTILITIES AND CHASSIS-CABS)

Hood Profile – Chevy, 2003 and Beyond MCE C/K 15/25 Chevrolet Pickups

Hood Profile – Chevy, 2003 MCE and 2004 C/K 25HD/35/36 Chevy Silverado Pickups and Chassis-Cabs

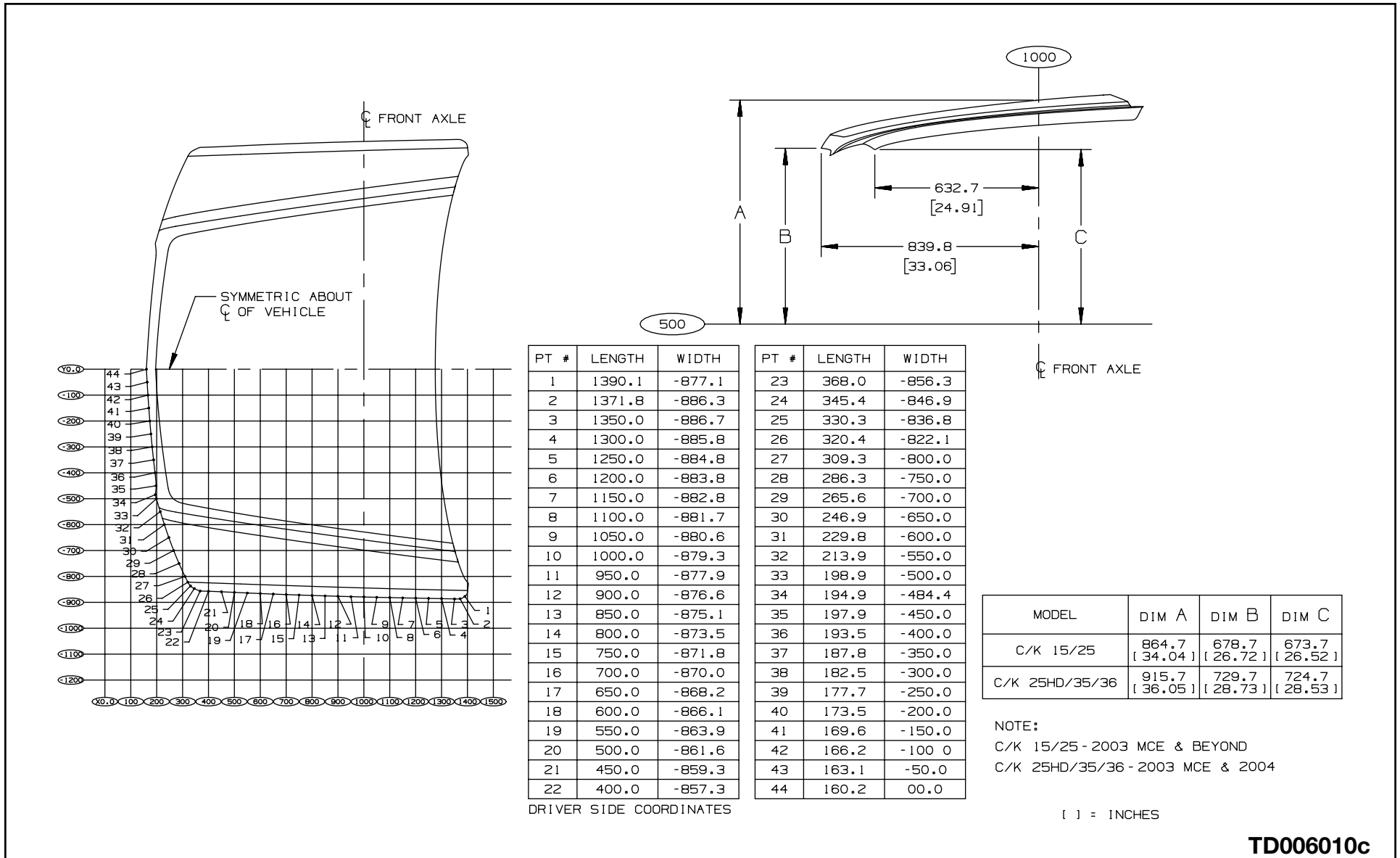

Hood Profile (Chevy) 25HD/35/36 2005 MCE and Beyond

HOOD PROFILE (CHEVY)
2005, MID-CYCLE ENHANCEMENT
C/K (25HD/35/36) (03/43/53)

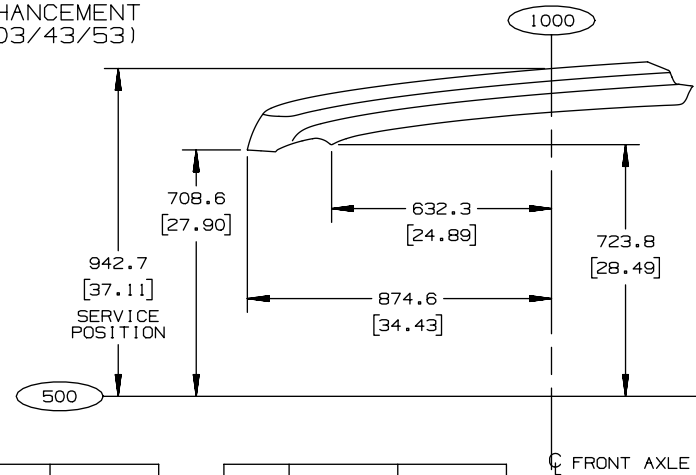
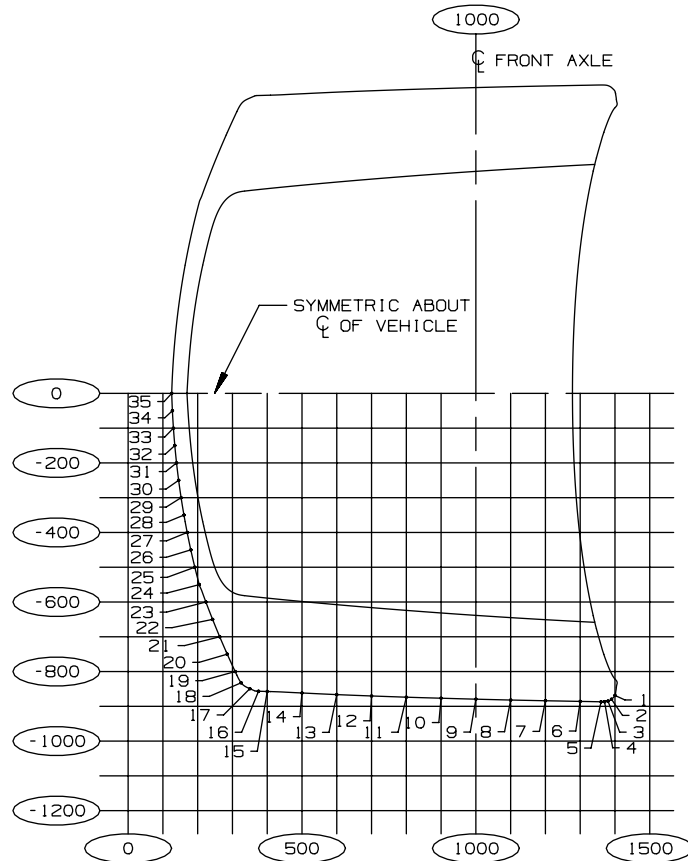

PT#	LENGTH	WIDTH
1	1400.0	-868.7
2	1390.0	-879.7
3	1380.0	-885.1
4	1370.0	-886.7
5	1360.0	-886.9
6	1300.0	-885.8
7	1200.0	-884.0
8	1100.0	-881.9
9	1000.0	-879.4
10	900.0	-876.7
11	800.0	-873.7
12	700.0	-870.2
13	600.0	-866.3
14	500.0	-861.6
15	400.0	-857.3
16	375.0	-856.6
17	350.0	-849.3
18	325.0	-832.4

PT#	LENGTH	WIDTH
19	307.8	-800.0
20	285.0	-750.0
21	263.4	-700.0
22	242.9	-650.0
23	223.6	-600.0
24	204.6	-550.0
25	191.8	-500.0
26	180.2	-450.0
27	169.8	-400.0
28	160.5	-350.0
29	152.3	-300.0
30	145.3	-250.0
31	139.2	-200.0
32	134.2	-150.0
33	130.3	-100.0
34	127.3	-50.0
35	125.3	0.0

DRIVER SIDE COORDINATES

02JL04 N1

[] = INCHES

TD006010h

C/K (15/25) Hood Profile (GMC)

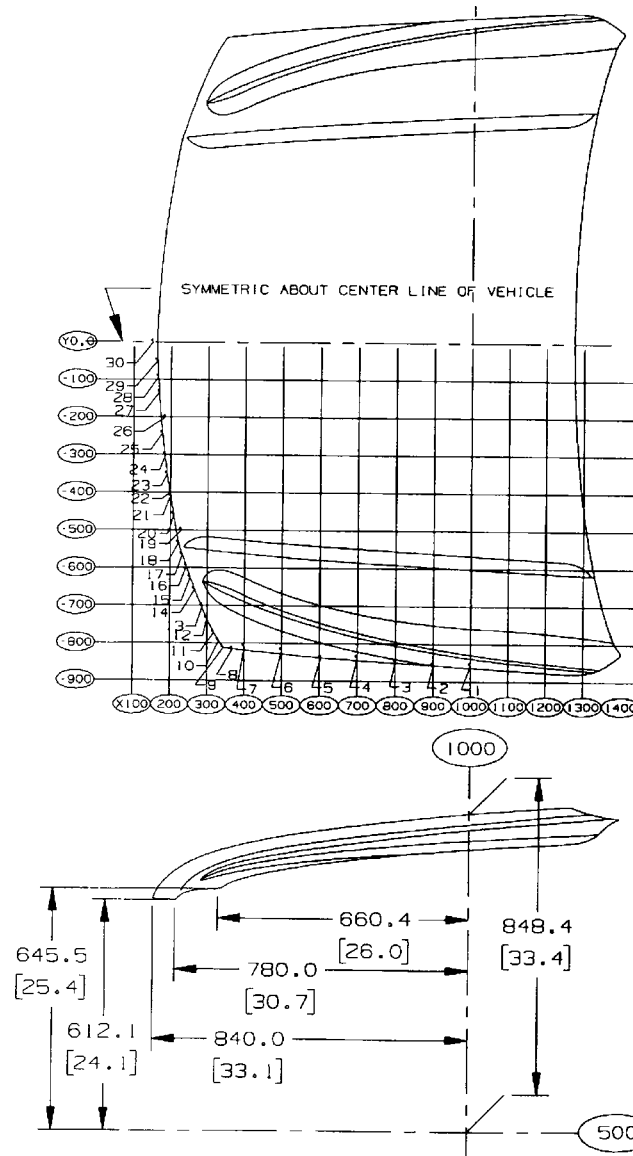

PT#	LENGTH	WIDTH
1	1000.0	-863.8
2	900.0	-857.7
3	800.0	-851.5
4	700.0	-845.0
5	600.0	-837.7
6	500.0	-829.2
7	400.0	-819.0
8	364.4	-815.2
9	343.4	-812.4
10	334.5	-800.0
11	317.2	-772.3
12	300.0	-739.7
13	281.9	-700.0
14	267.8	-663.5
15	254.9	-629.0
16	244.5	-600.0
17	232.7	-568.8
18	223.3	-536.5
19	215.5	-500.0
20	209.0	-464.0
21	200.0	-410.0
22	197.9	-400.0
23	192.0	-358.1
24	183.7	-300.0
25	178.3	-249.7
26	173.5	-200.0
27	168.6	-141.8
28	165.6	-100.0
29	163.6	-33.5
30	161.5	00.0

DRIVER SIDE COORDINATES

C/K (25HD/35/36) Hood Profile (GMC)

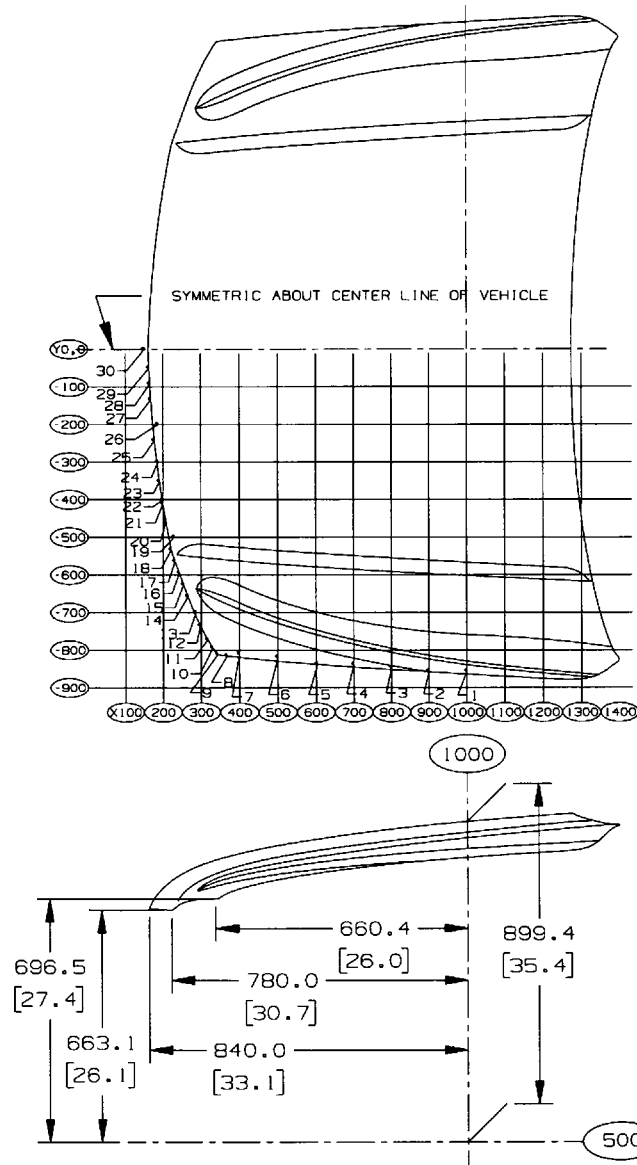

PT#	LENGTH	WIDTH
1	1000.0	-863.8
2	900.0	-857.7
3	800.0	-851.5
4	700.0	-845.0
5	600.0	-837.7
6	500.0	-829.2
7	400.0	-819.0
8	364.4	-815.2
9	343.4	-812.4
10	334.5	-800.0
11	317.2	-772.3
12	300.0	-739.7
13	281.9	-700.0
14	267.8	-663.5
15	254.9	-629.0
16	244.5	-600.0
17	232.7	-568.8
18	223.3	-536.5
19	215.5	-500.0
20	209.0	-464.0
21	200.0	-410.0
22	197.9	-400.0
23	192.0	-358.1
24	183.7	-300.0
25	178.3	-249.7
26	173.5	-200.0
27	168.6	-141.8
28	165.6	-100.0
29	163.6	-33.5
30	161.5	00.0

DRIVER SIDE COORDINATES

C/K (15/25)936 Hood Profile

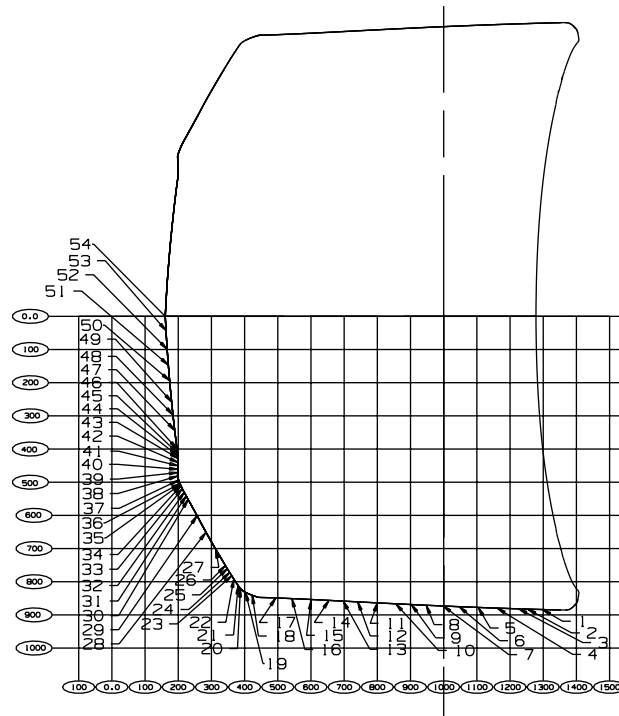

1:1 INCHES

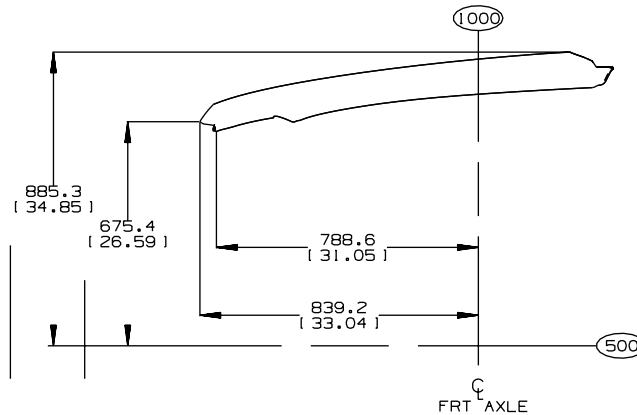

PT #	LENGTH	WIDTH
1	1300.0	-883.9
2	1250.0	-882.4
3	1200.0	-880.9
4	1150.0	-879.1
5	1100.0	-877.3
6	1050.0	-875.3
7	1000.0	-873.2
8	950.0	-870.9
9	900.0	-868.6
10	850.0	-866.1
11	800.0	-863.7
12	750.0	-861.1
13	700.0	-858.5
14	650.0	-856.0
15	600.0	-853.4
16	550.0	-851.3
17	500.0	-849.1
18	422.3	-840.6
19	400.0	-830.6
20	387.1	-820.6
21	397.9	-810.6
22	372.8	-800.0
23	366.8	-790.6
24	360.2	-780.6
25	353.9	-770.6
26	347.7	-760.6
27	341.8	-750.6
28	311.9	-700.6
29	283.3	-650.6
30	256.2	-600.0
31	228.9	-550.6
32	223.5	-540.6
33	218.0	-530.6
34	212.6	-520.6
35	207.9	-510.6
36	203.4	-500.0
37	200.1	-490.2
38	198.0	-480.3
39	198.2	-470.2
40	198.6	-460.6
41	199.1	-450.6
42	199.7	-440.6
43	200.2	-430.4
44	199.2	-420.6
45	197.7	-410.6
46	196.3	-400.0
47	190.3	-350.0
48	184.3	-300.0
49	179.3	-250.0
50	174.4	-200.0
51	170.4	-150.0
52	166.5	-100.0
53	163.6	-50.0
54	160.7	-0.0

DRIVER SIDE COORDINATES

C/K (15/25/25HD/35/36) Hood Inner Panel

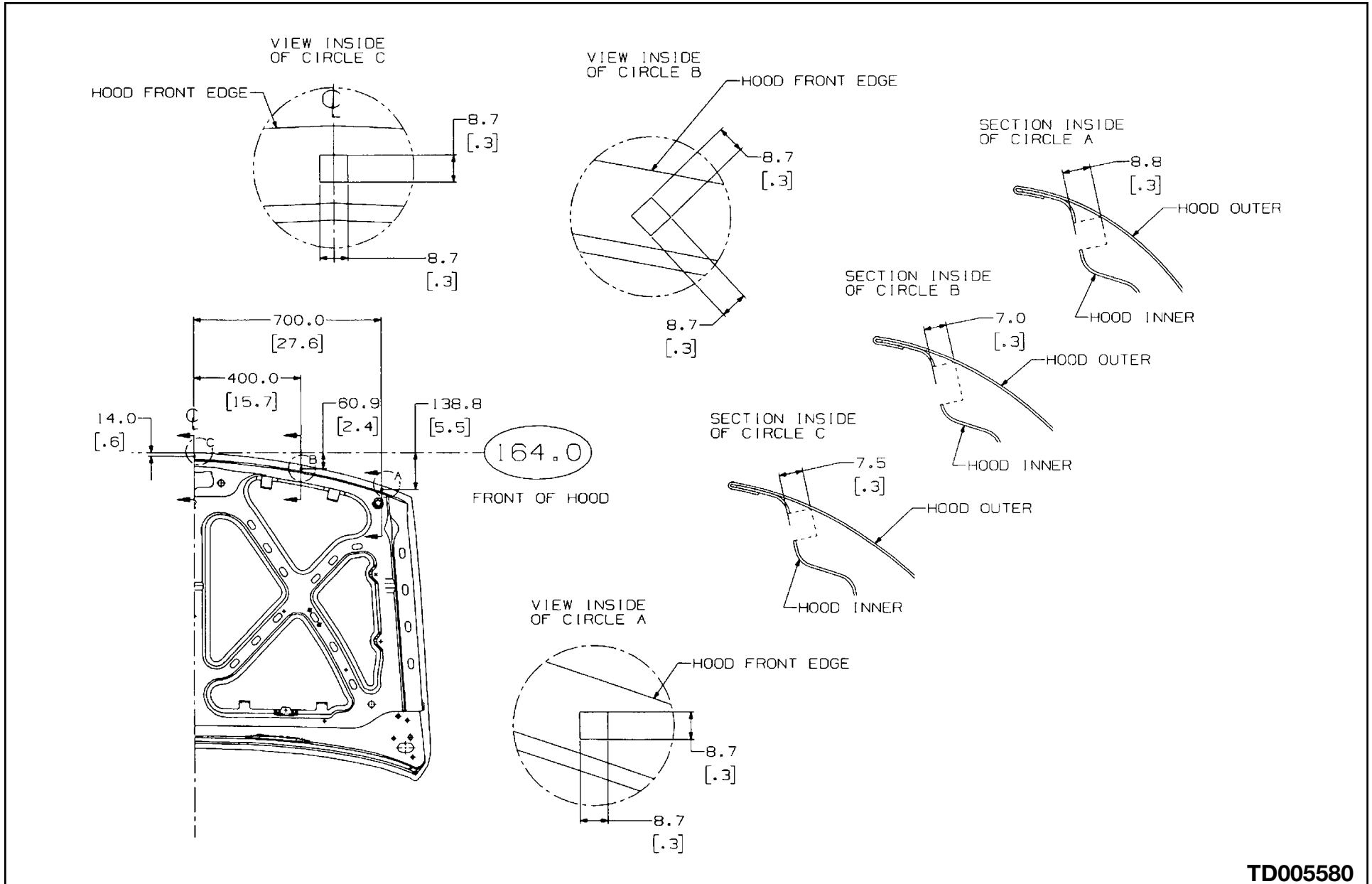

TD005580

C/K 15543 Short Short Fleetside Box

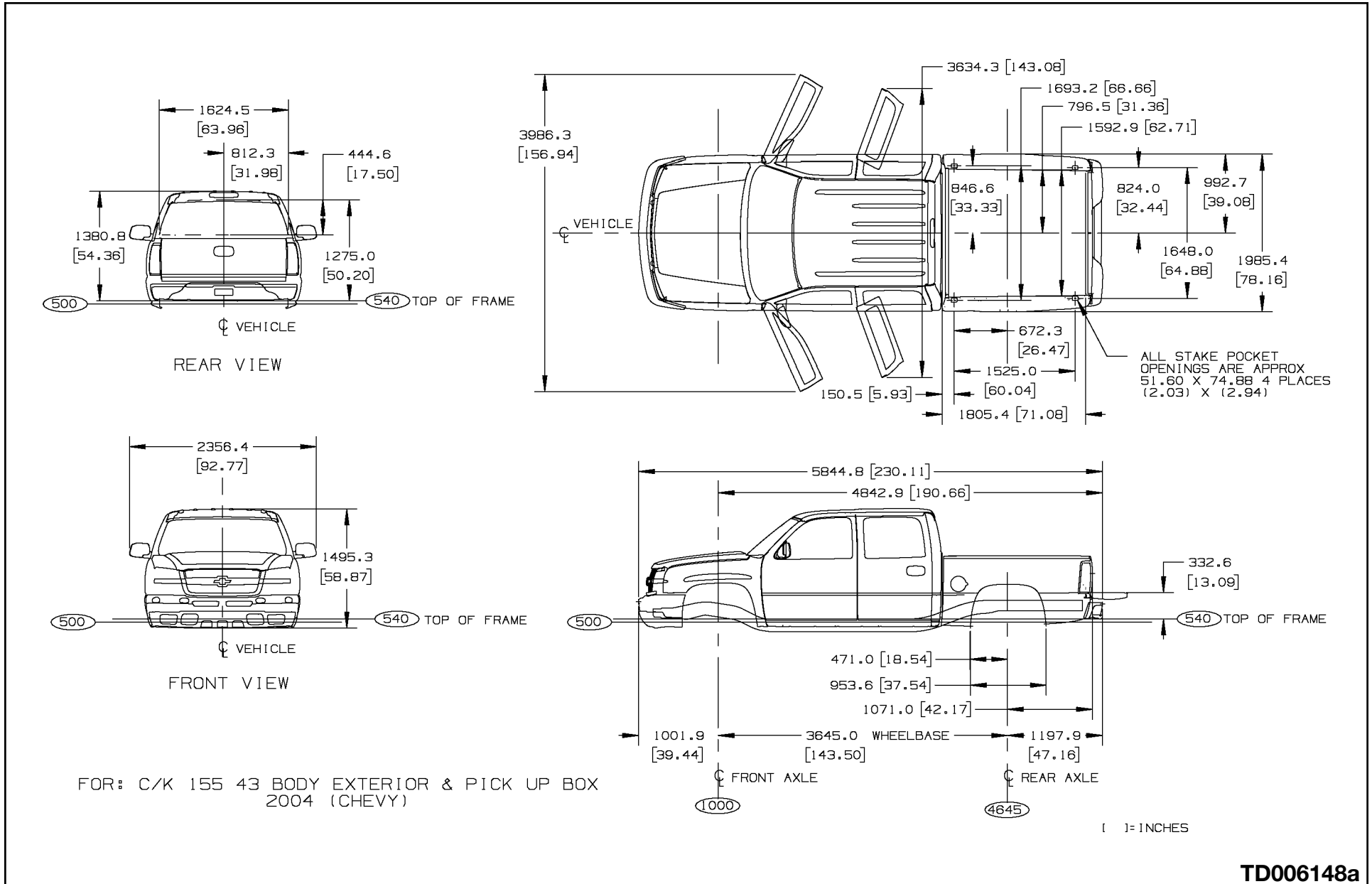

TD006148a

C/K 6.5 and 8.0 Foot Fleetside Pickup Box

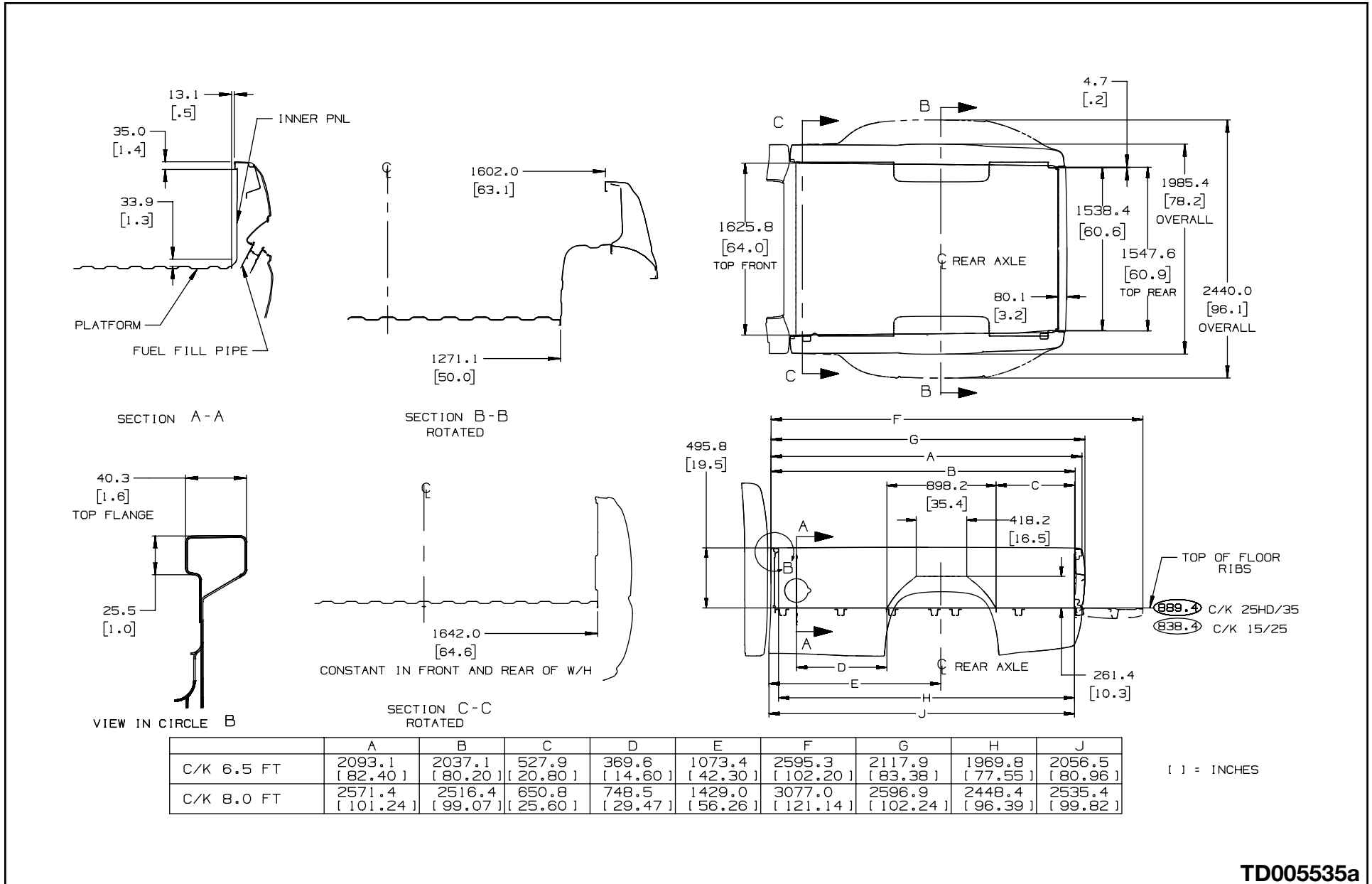

TD005535a

C/K Fleetside 6.5 Foot with Quad Steering (Option NYS)

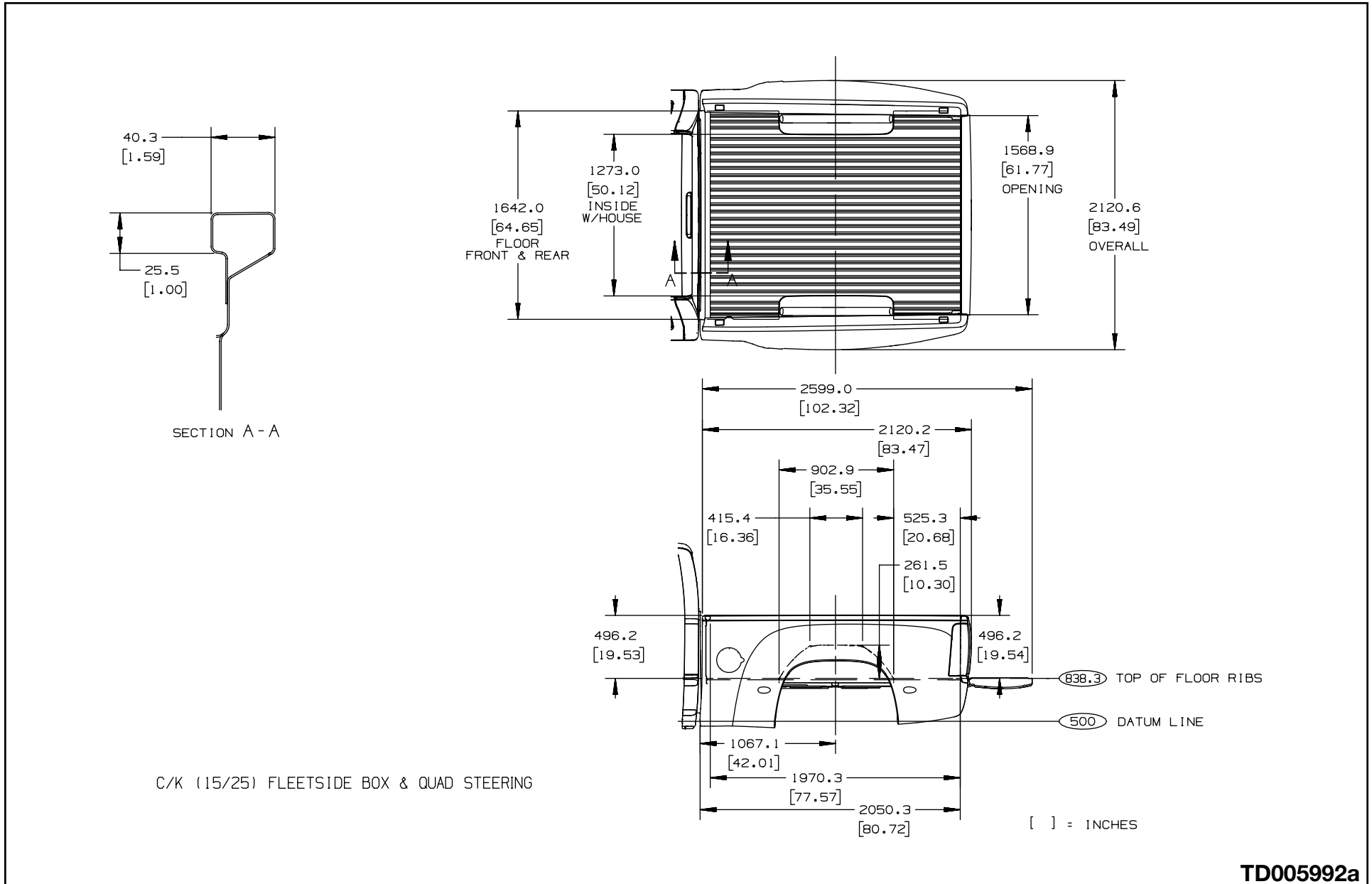

TD005992a

C/K (15/25/25HD/35) Stake Pockets

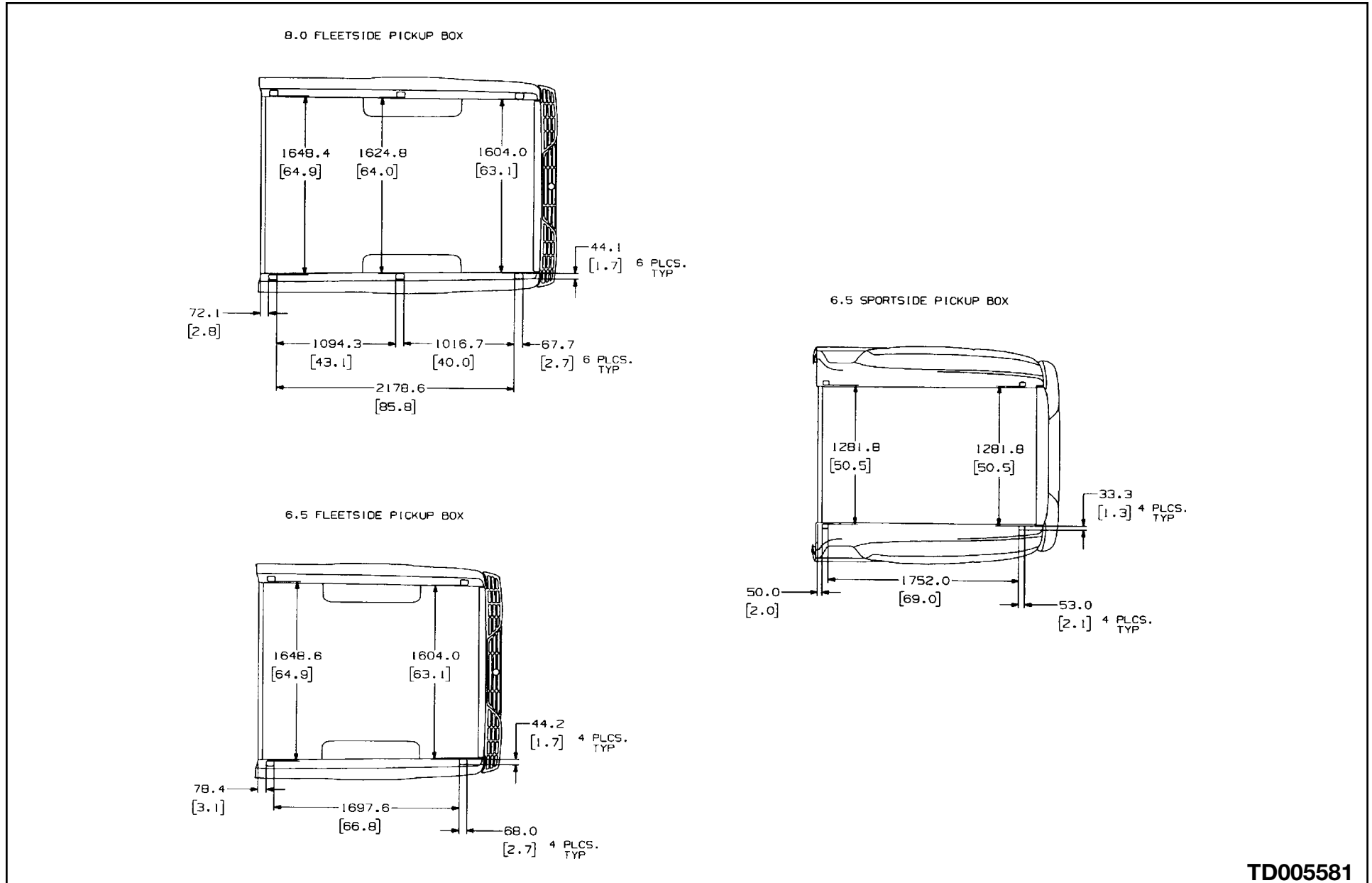

TD005581

2005 & BEYOND C/K FULL SIZE TRUCKS (PICKUPS, UTILITIES AND CHASSIS-CABS)

2005 and Beyond Pickup Box Electrical Plus Outlet Location – C/K15753, Hybrid Option HPT

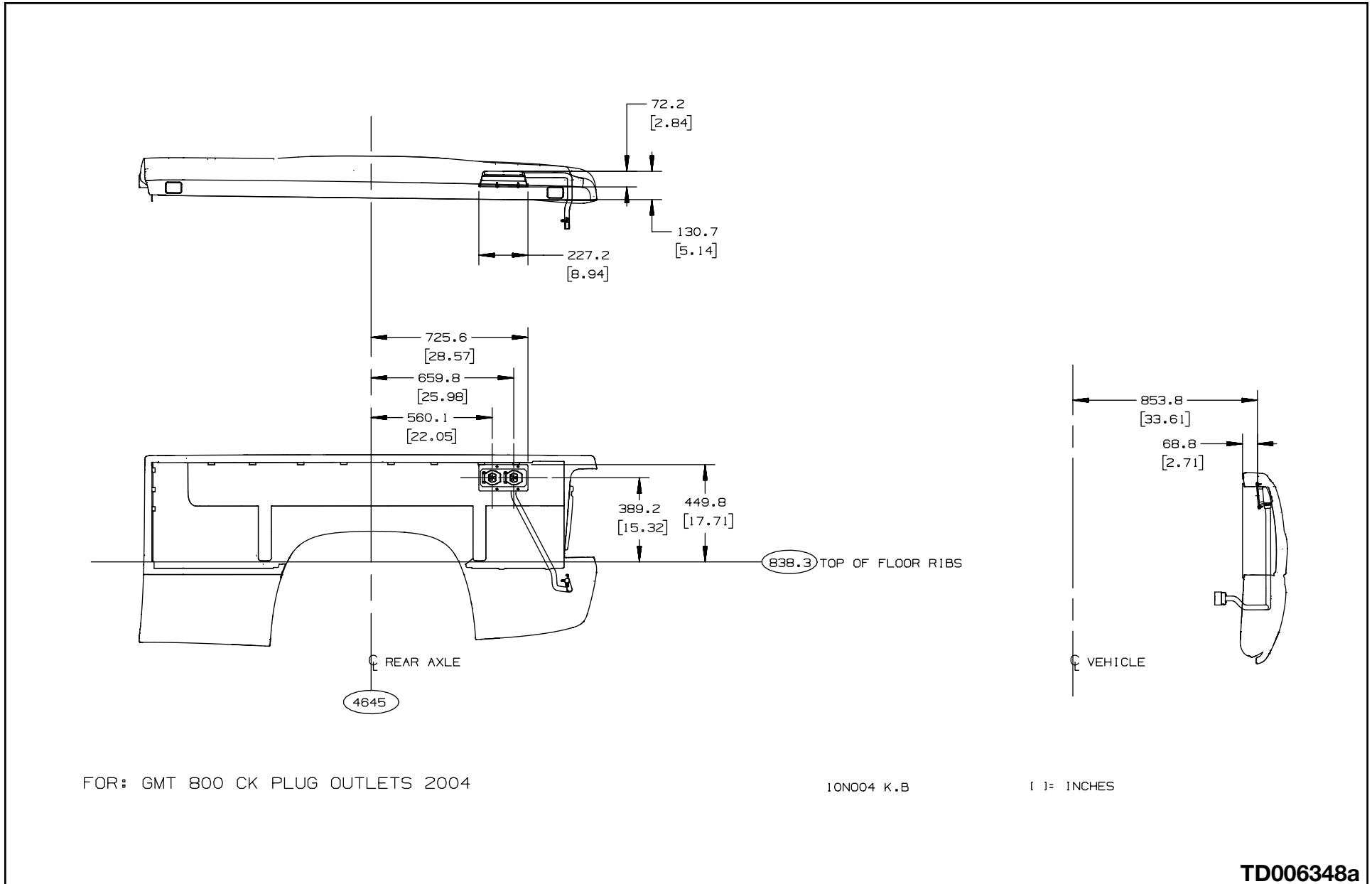

C/K (15/25/25HD/35) Fleetside Box, Top Rail

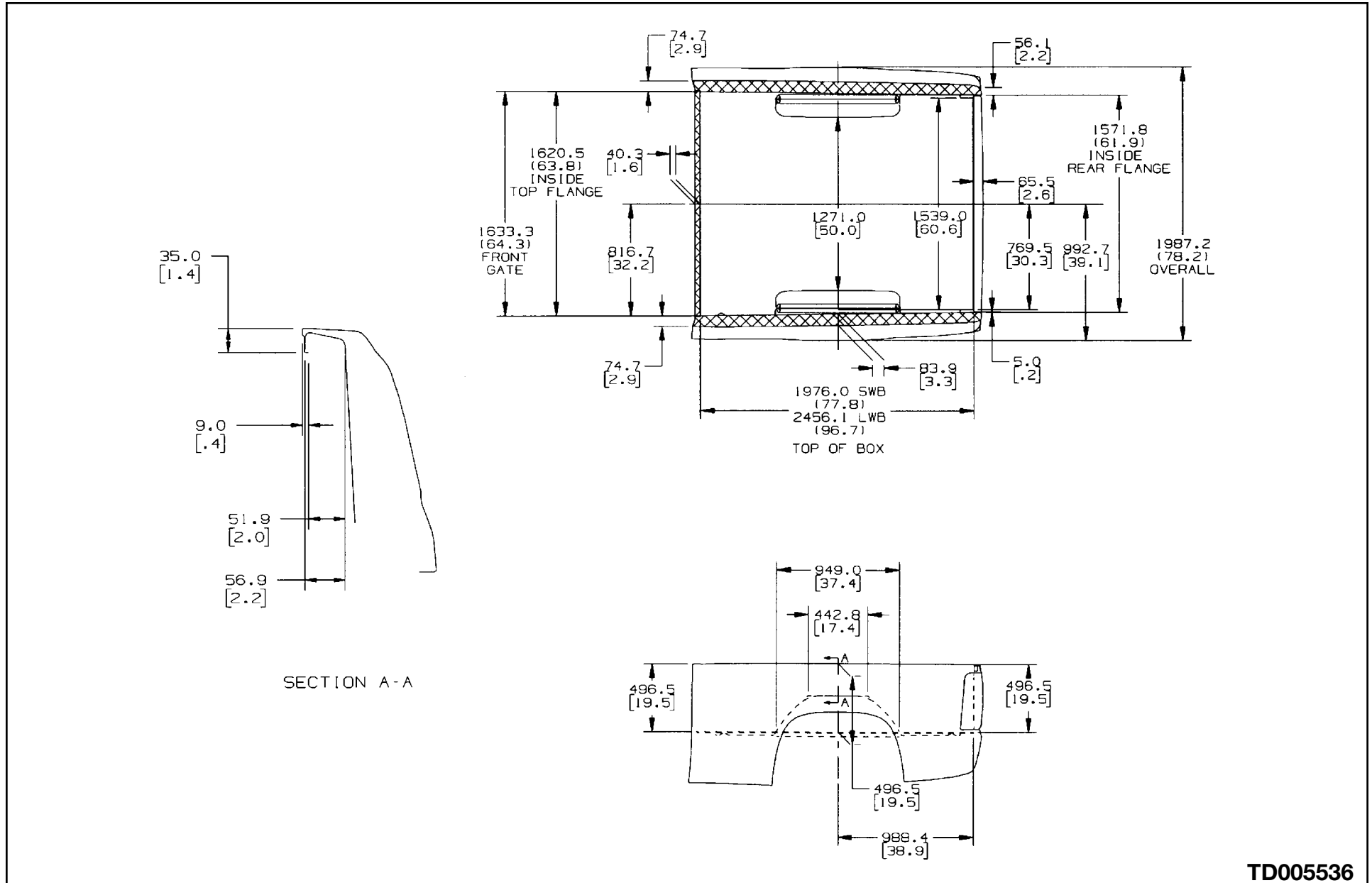

TD005536

C/K 15543 Short Short Fleetside Box, Inner Panel

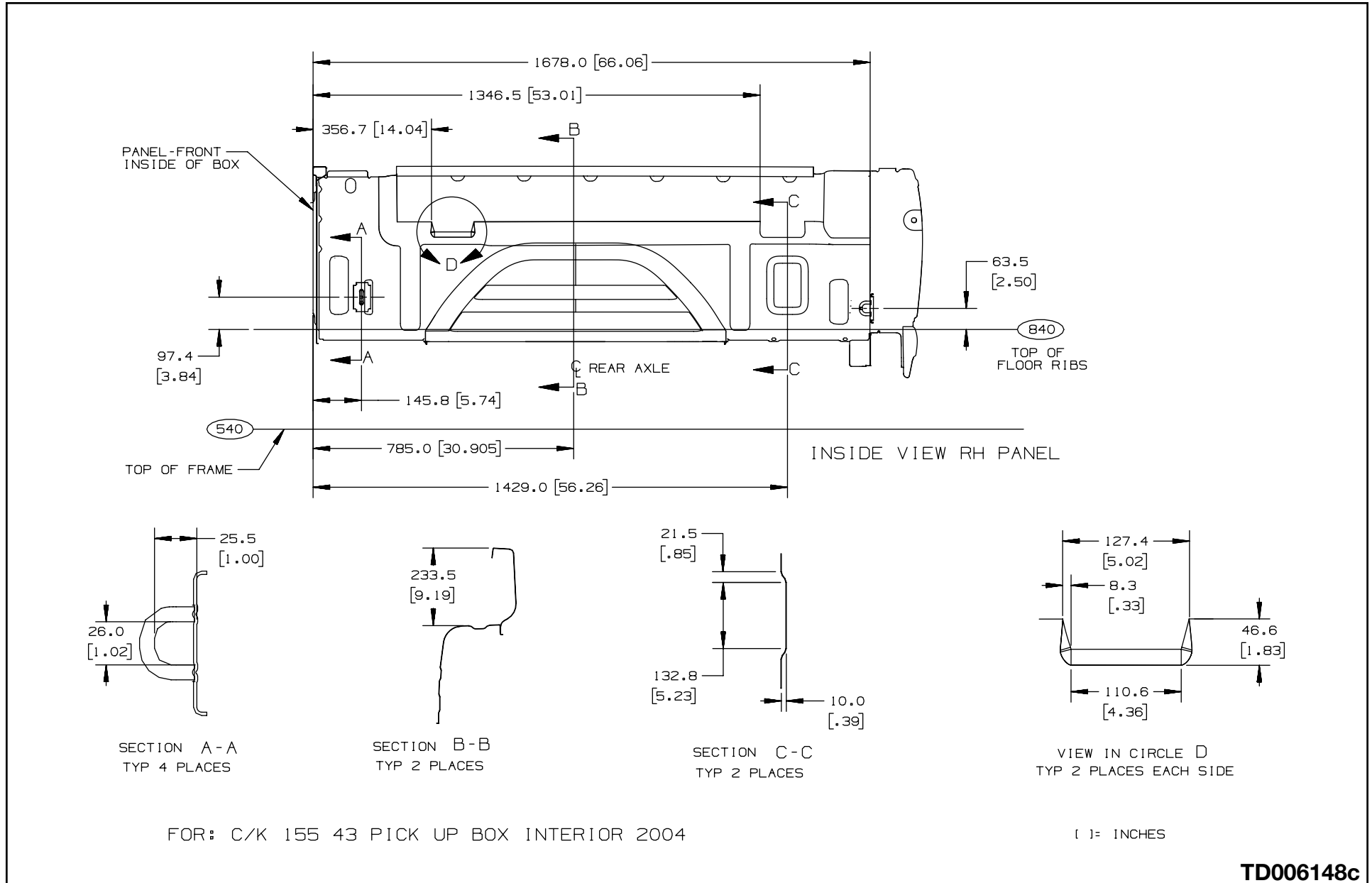

C/K (15/25) Fleetside Box Inner Side Panel

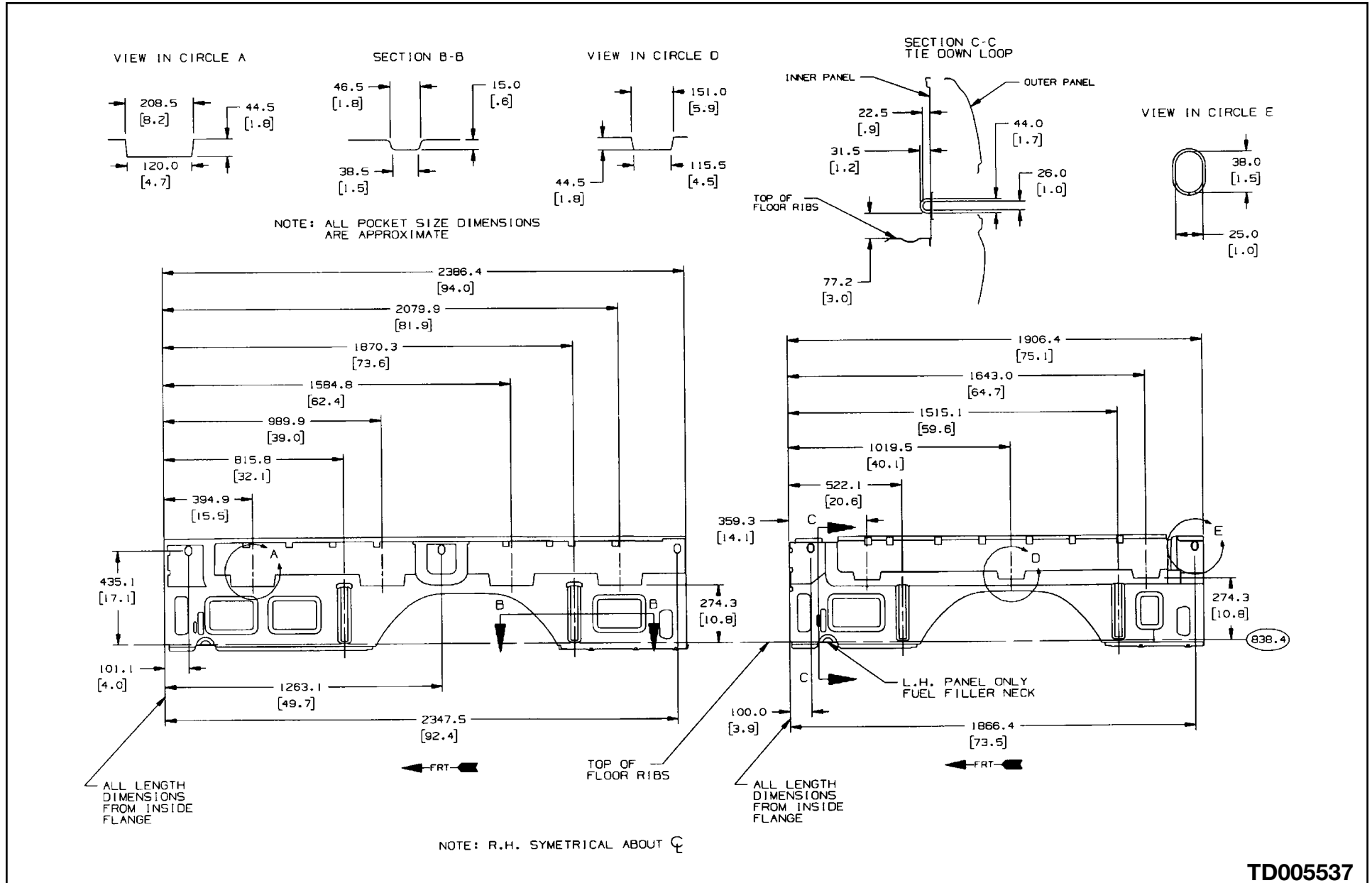

TD005537

C/K (25HD/35) Box Inner Side Panel

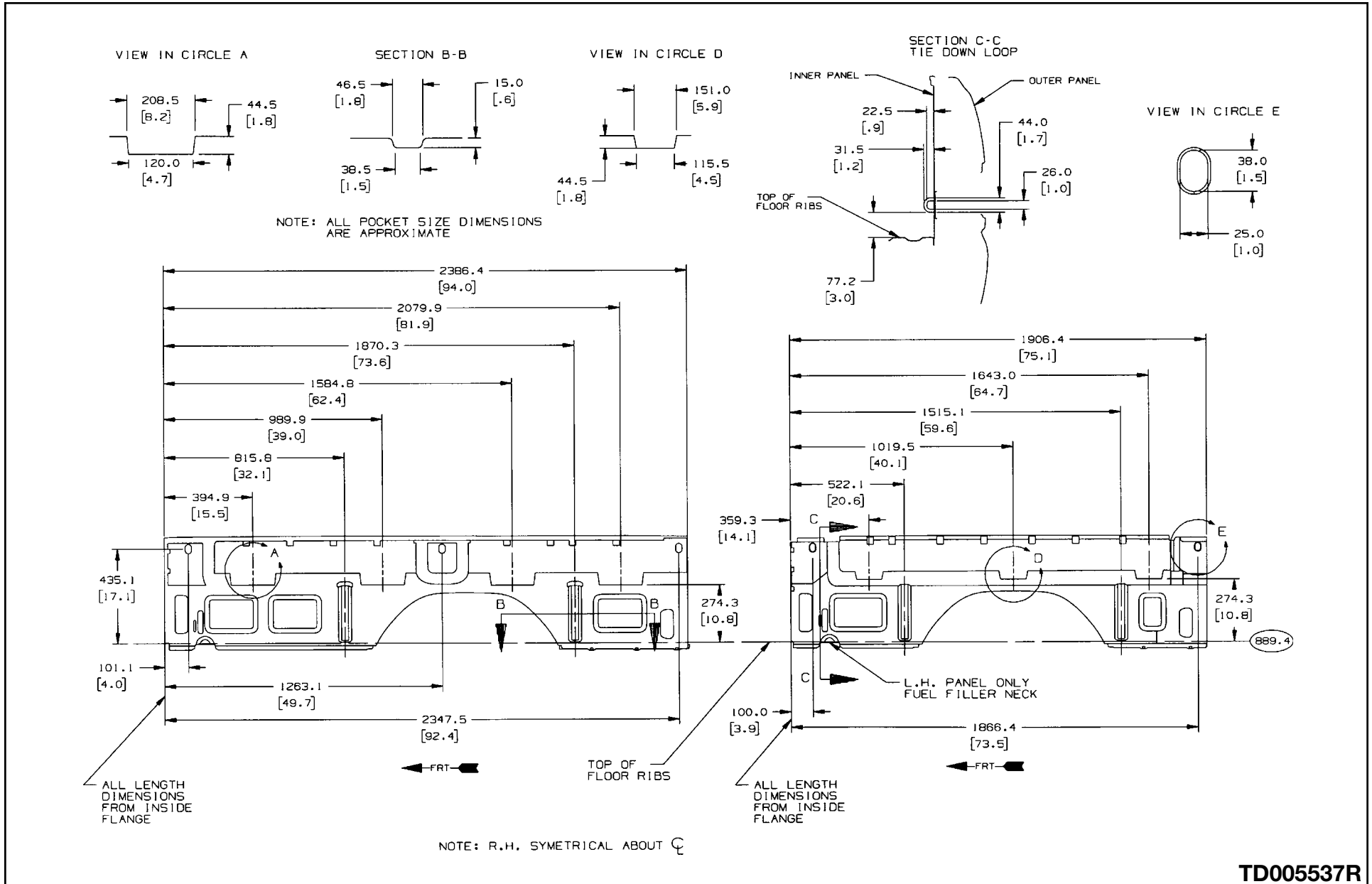

TD005537R

C/K 157(03/53) Sportside Box

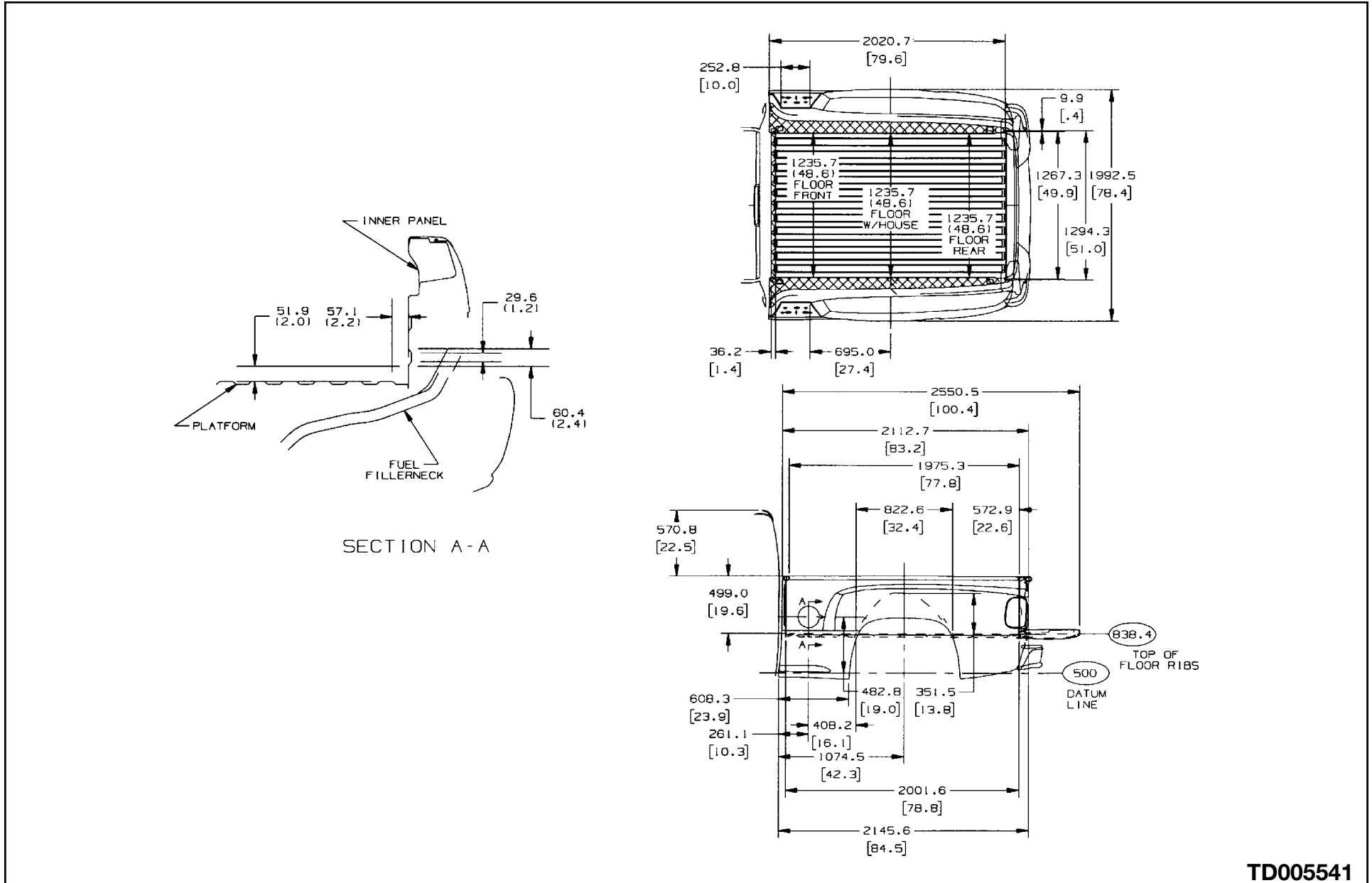

TD005541

C/K 157(03/53) Sportside Box, Top Rail

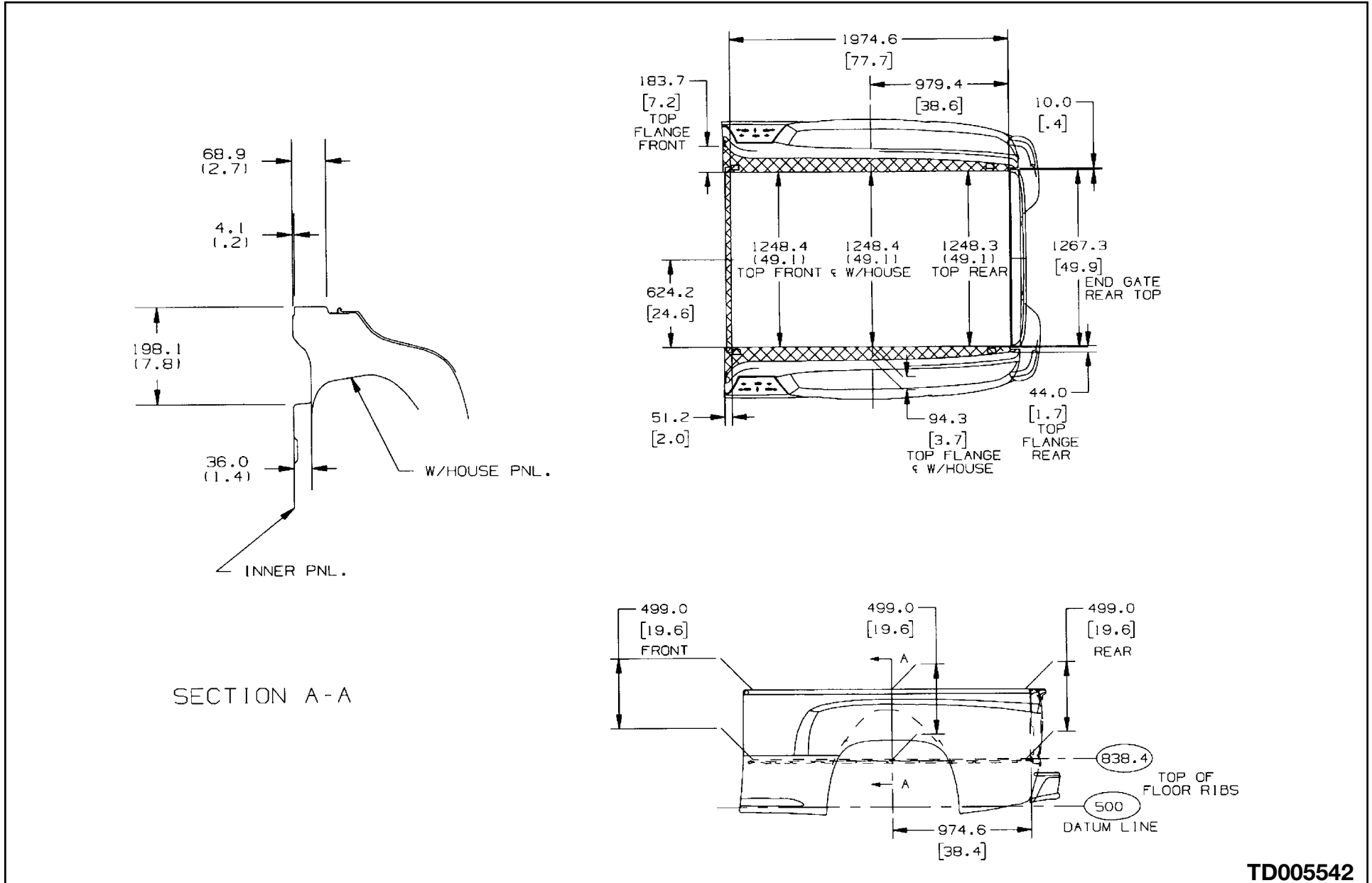

TD005542

C/K 157(03/53) Sportside, Inner Side Panel

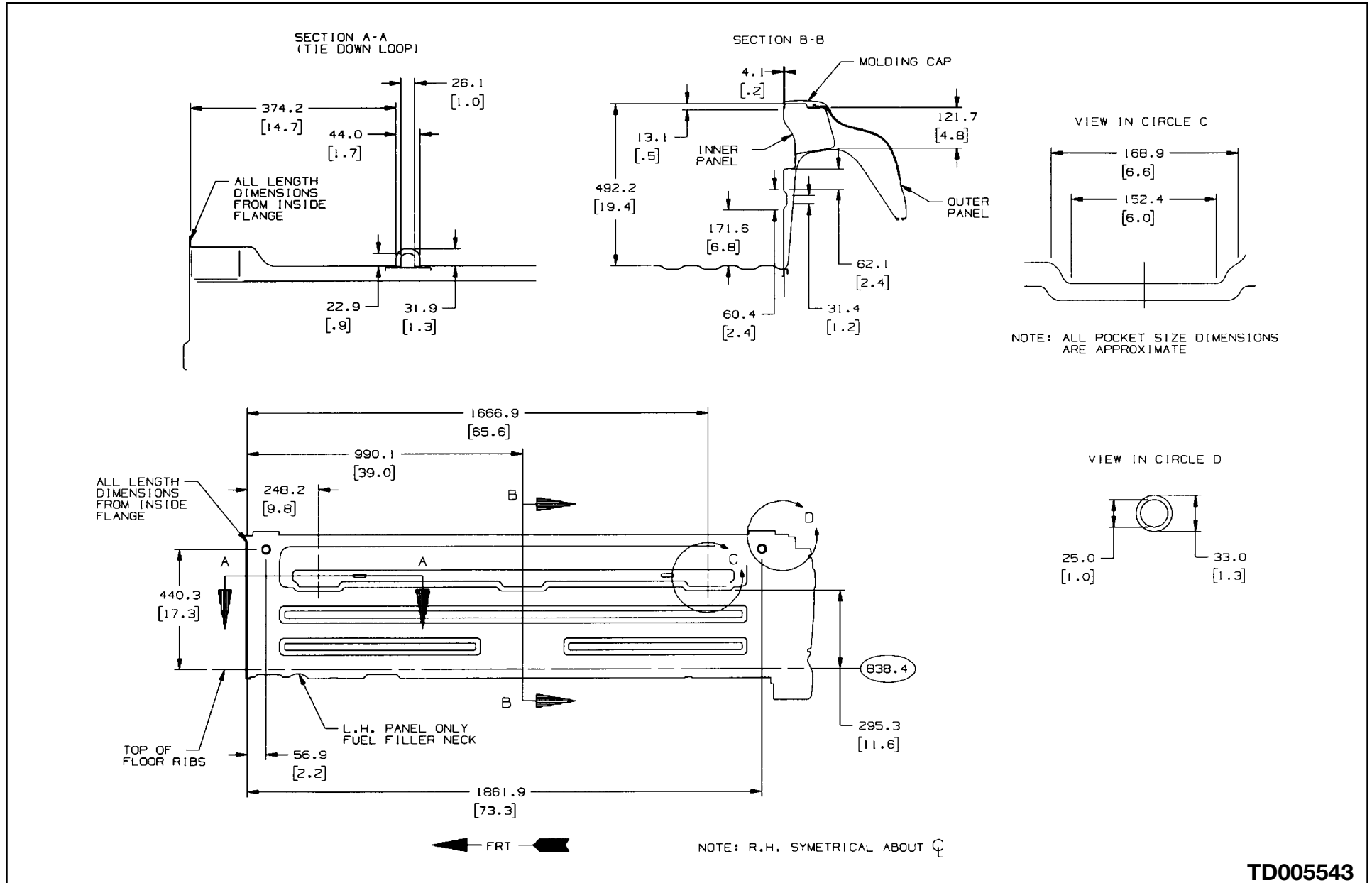

Platform Cross Sills – 5' 8.5" Pickup Box, Fleetside (Option E63)

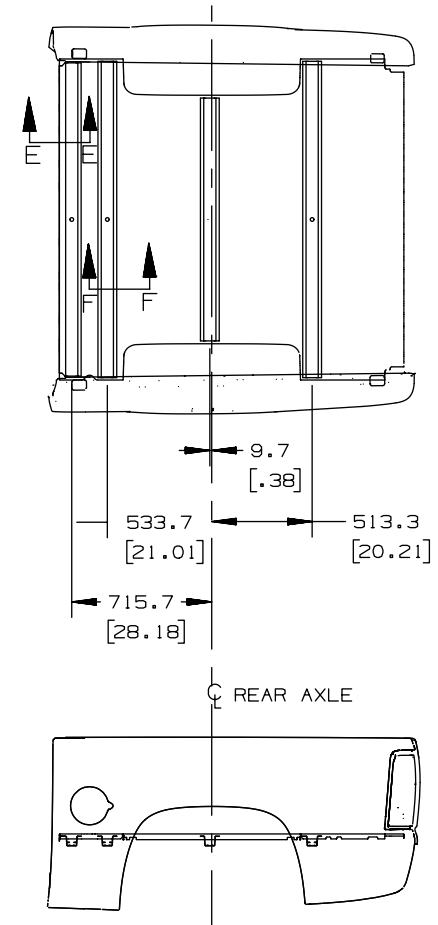
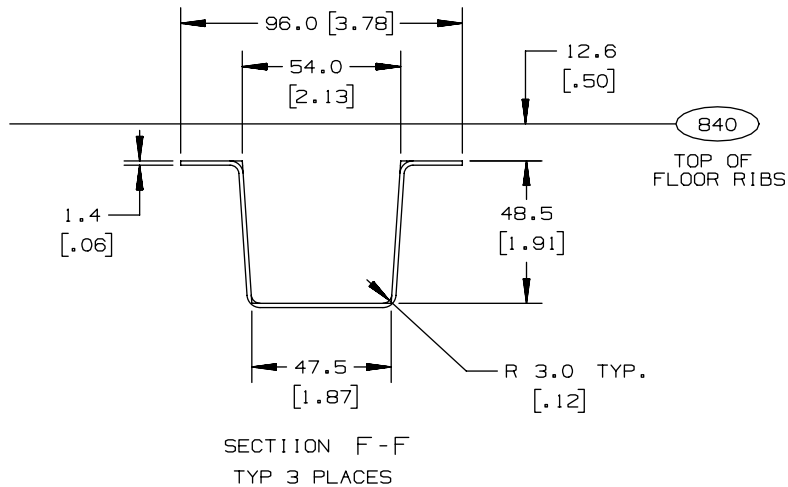
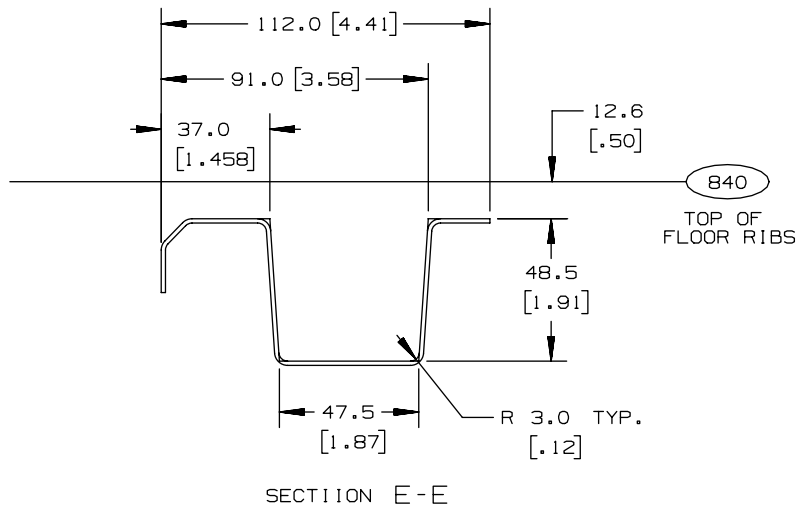

FOR: C/K 155 43 PLATFORM CROSS SILLS 2004

[] = INCHES

TD006148d

2005 & BEYOND C/K FULL SIZE TRUCKS (PICKUPS, UTILITIES AND CHASSIS-CABS)

Platform Cross Sills – 6.5 Foot Pickup Box, Fleetside (RPO E63), Sportside/Stepside (RPO E62)

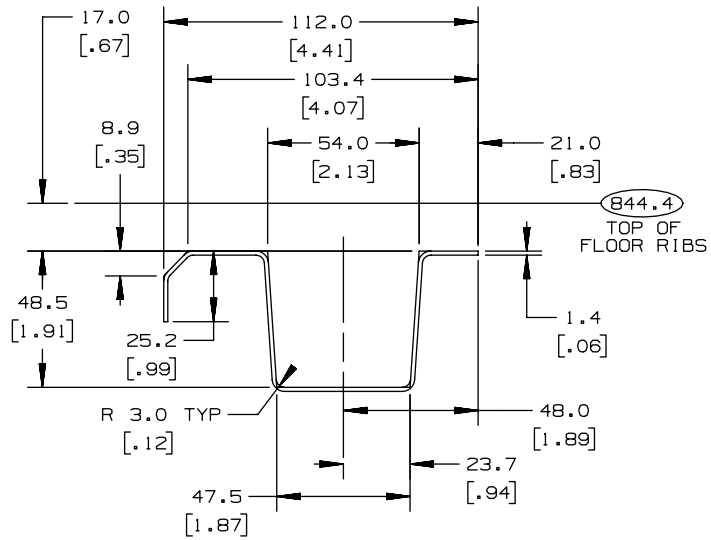

SECTION A-A

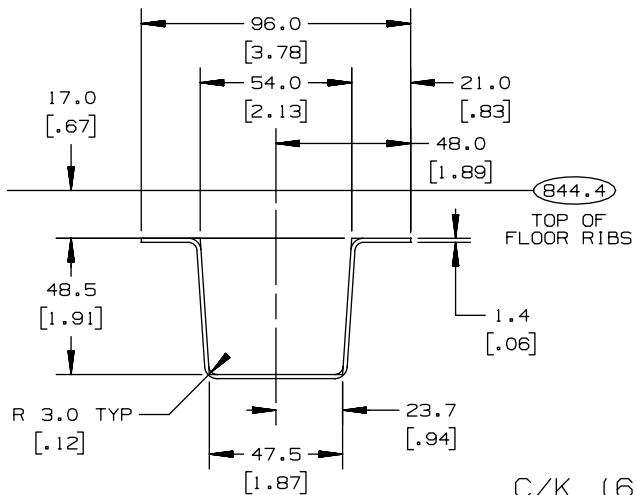

SECTION B-B
TYPICAL 3 PLACES

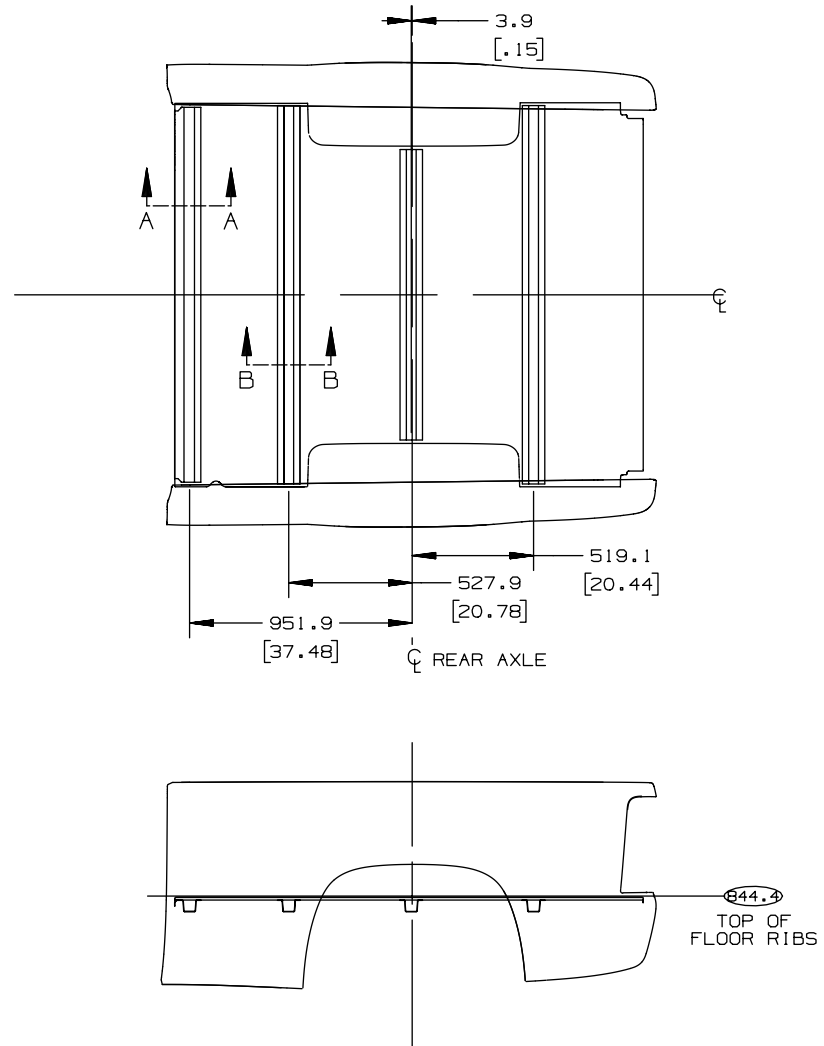

C/K (6.5) PLATFORM CROSS SILLS
FOR RPO - E62 STEPSIDE & SPORTSIDE
FOR RPO - E63 FLEETSIDE

[] = INCHES

TD005987b

Platform Cross Sills – 8 Foot Pickup Box, Fleetside (RPO E63)

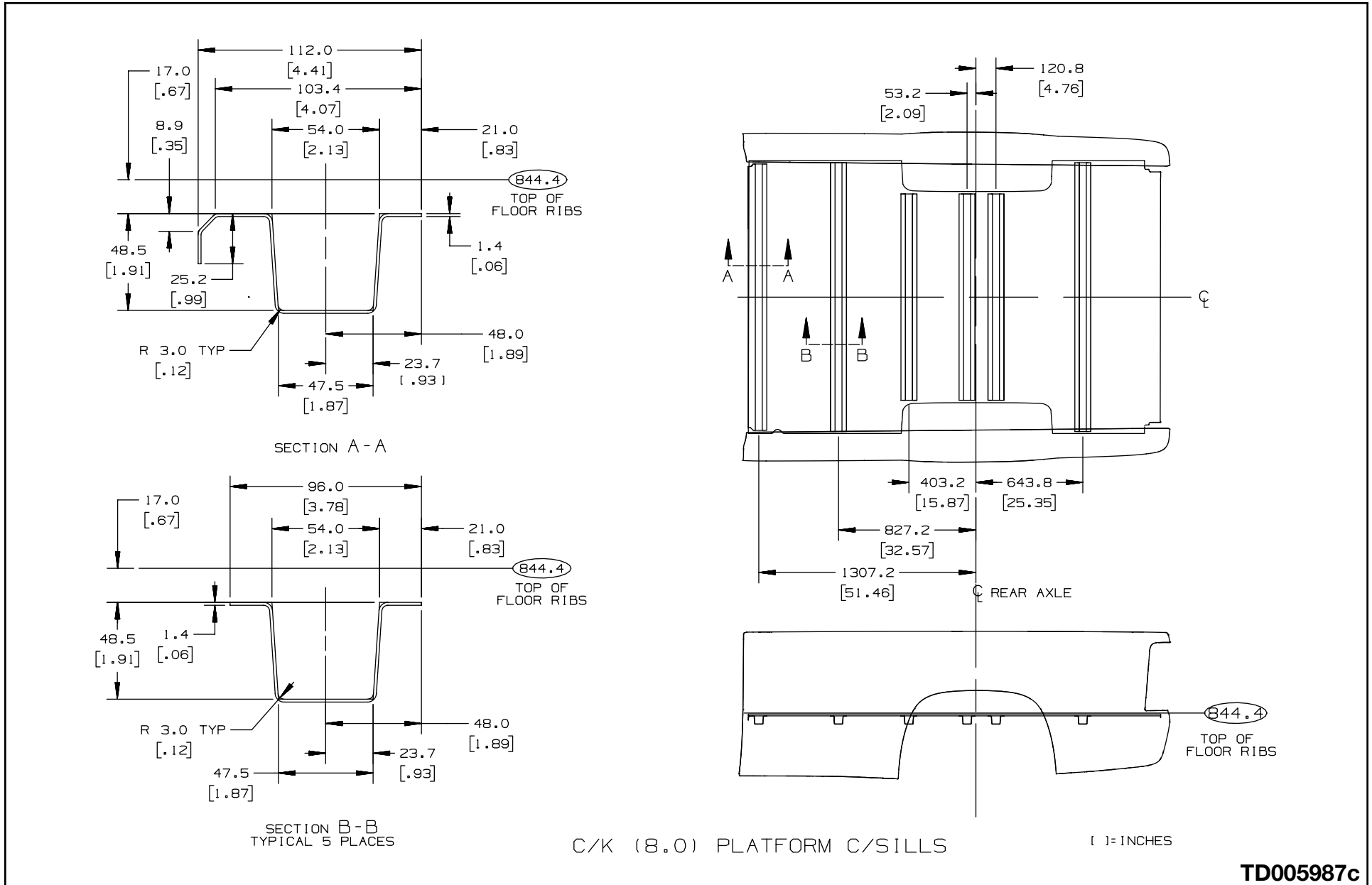

TD005987c

C/K (15/25)936 Cargo Area

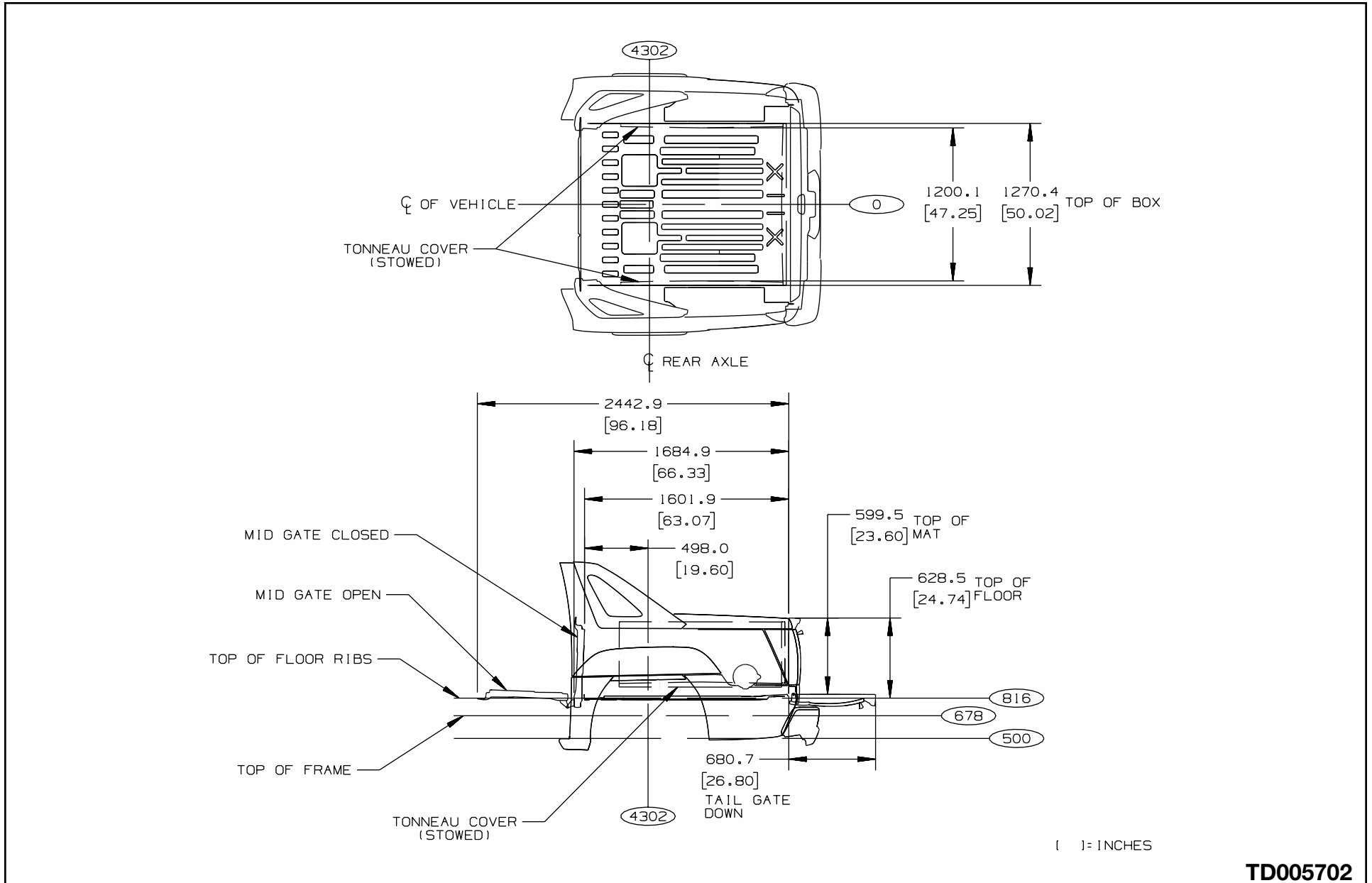

TD005702

C/K (15/25)936 Cargo Area Inner Side Panel

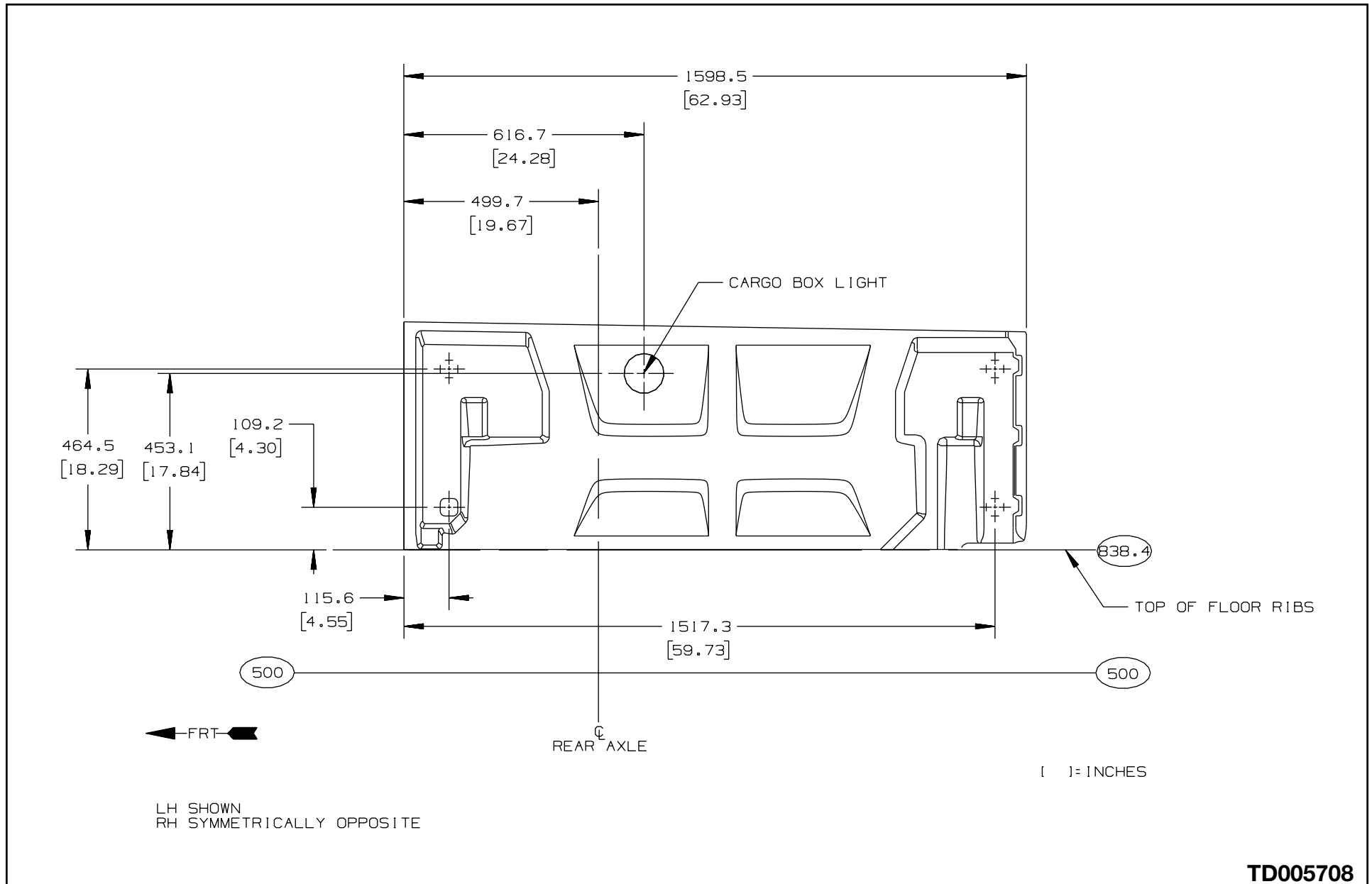

TD005708

C/K (15/25)936 Side Storage Compartment

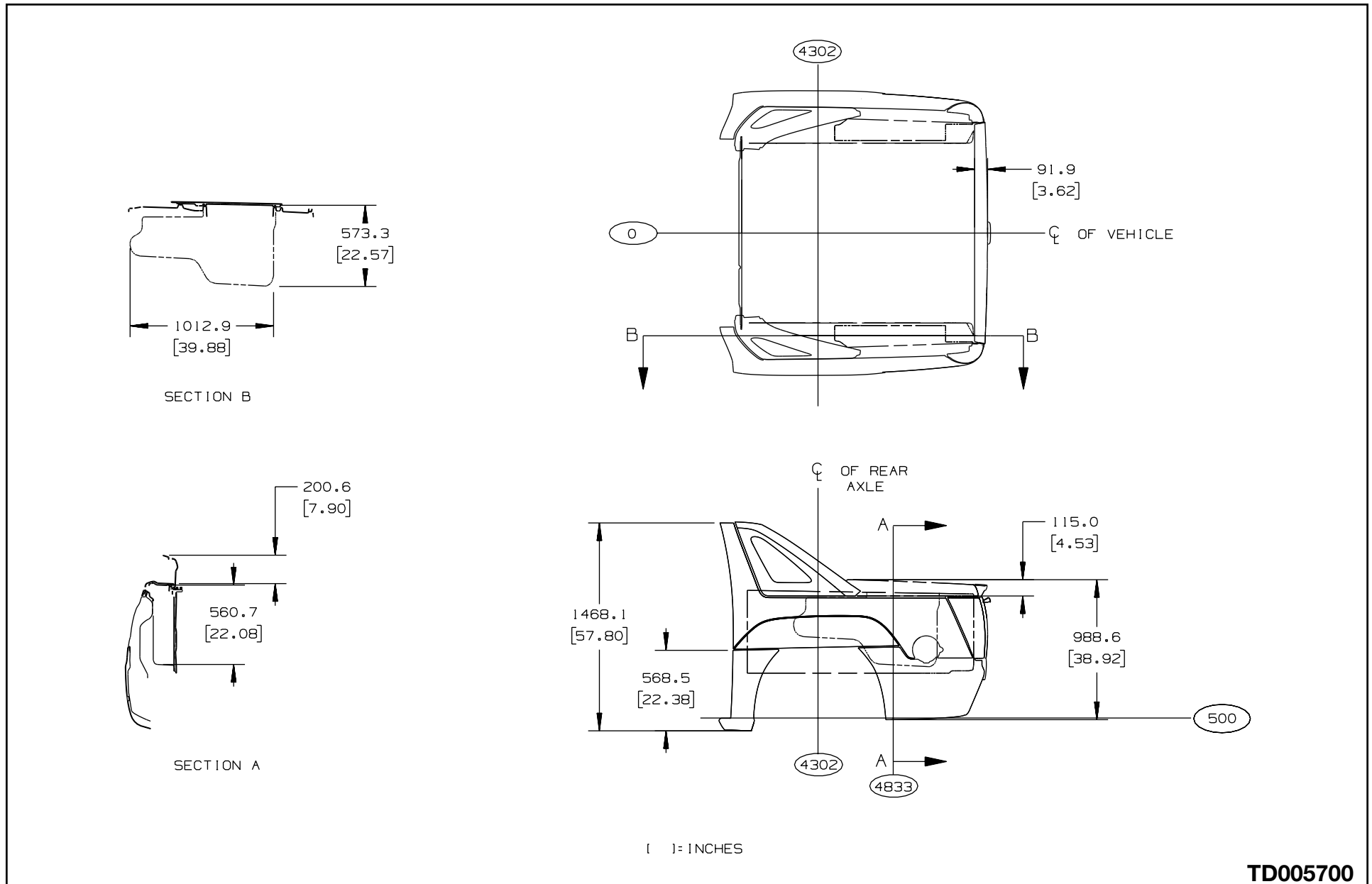

TD005700

C/K 15706 Luggage Rack and Running Boards

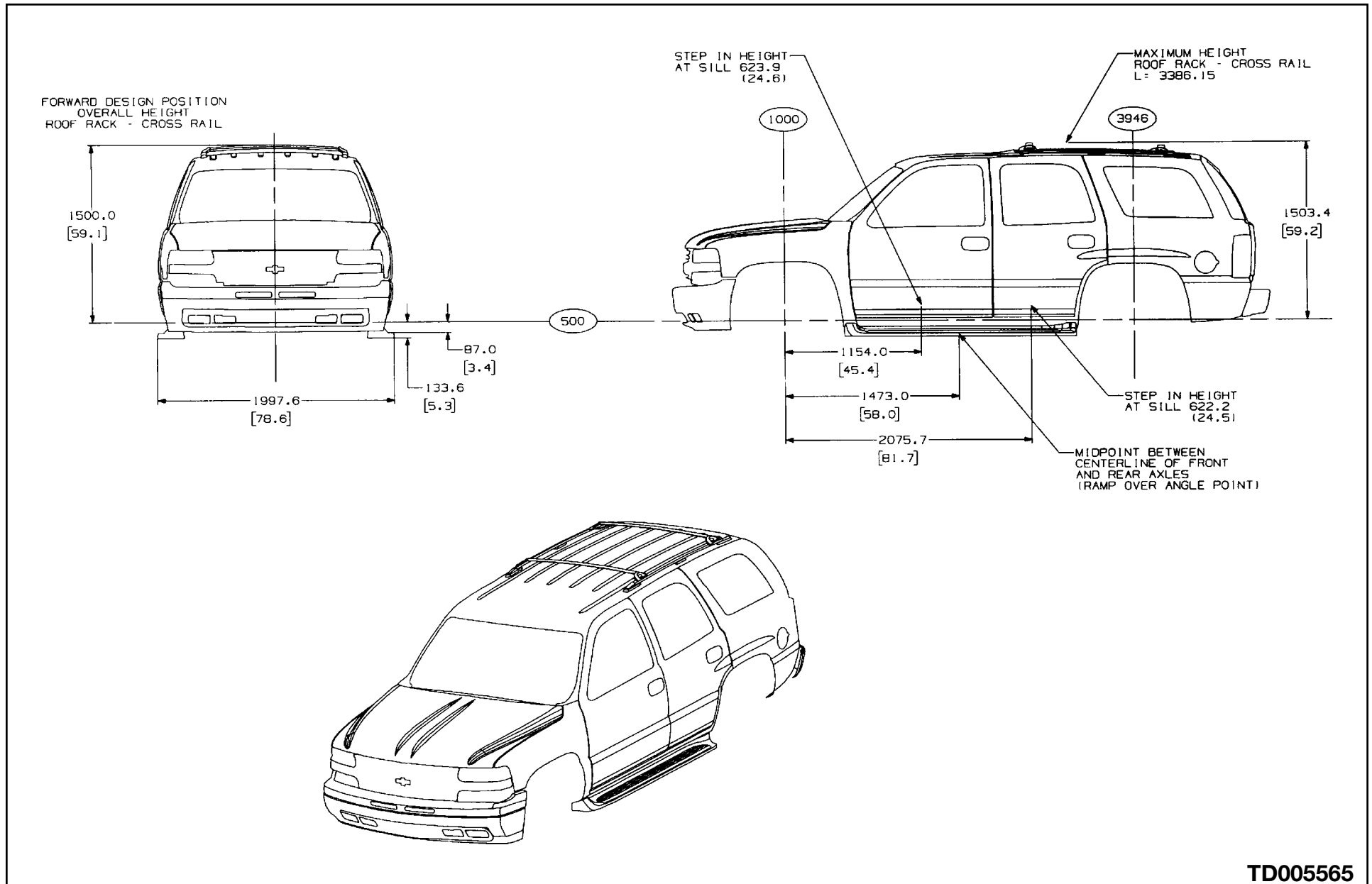

C/K (15/25)906 Luggage Rack and Running Boards

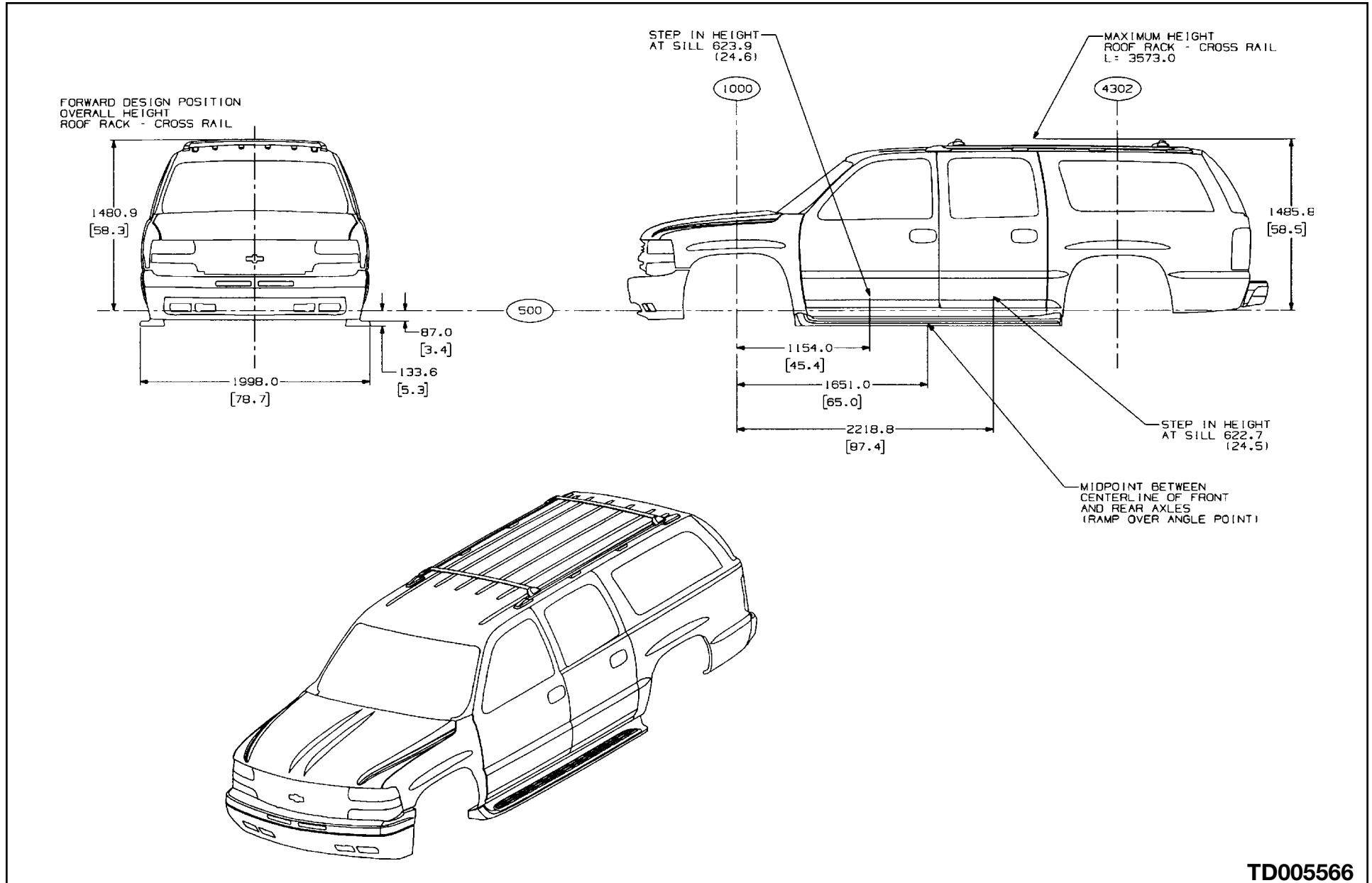

C/K (15/25)936 Running Board Mounting Location

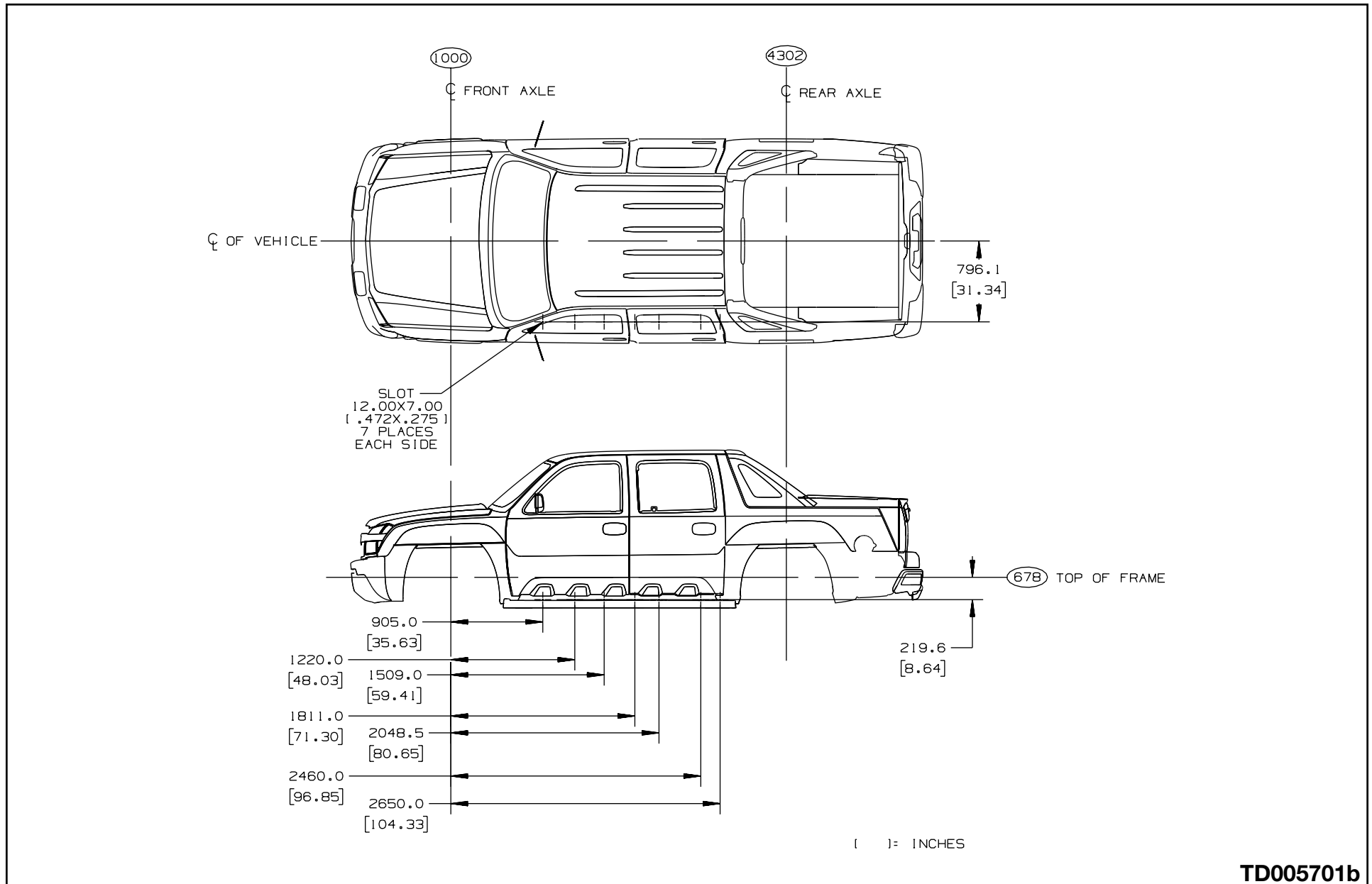

TD005701b

C/K (25HD/35/36) Clearance Lamps

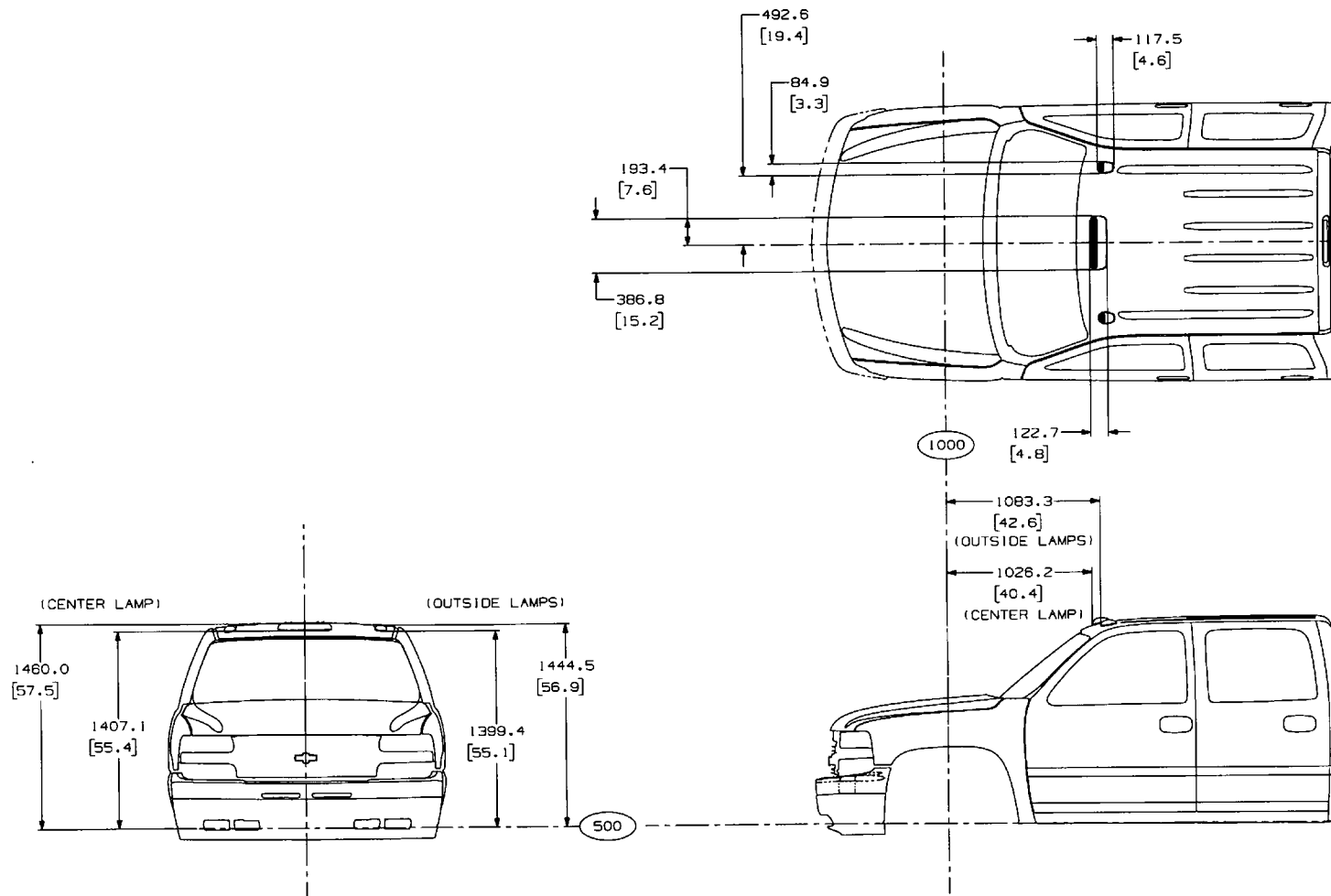

ALL DIMENSIONS HAVE INCORPORATED THE 51MM HEIGHT MOVEMENT DRIVEN BY THE M74 TRANSMISSION UNLESS OTHERWISE NOTED

ALL DIMENSIONS SHOWN FOR CHEVY BASE MODEL UNLESS OTHERWISE NOTED

TD005579

C/K (36) Pressure Relief Valve Shield

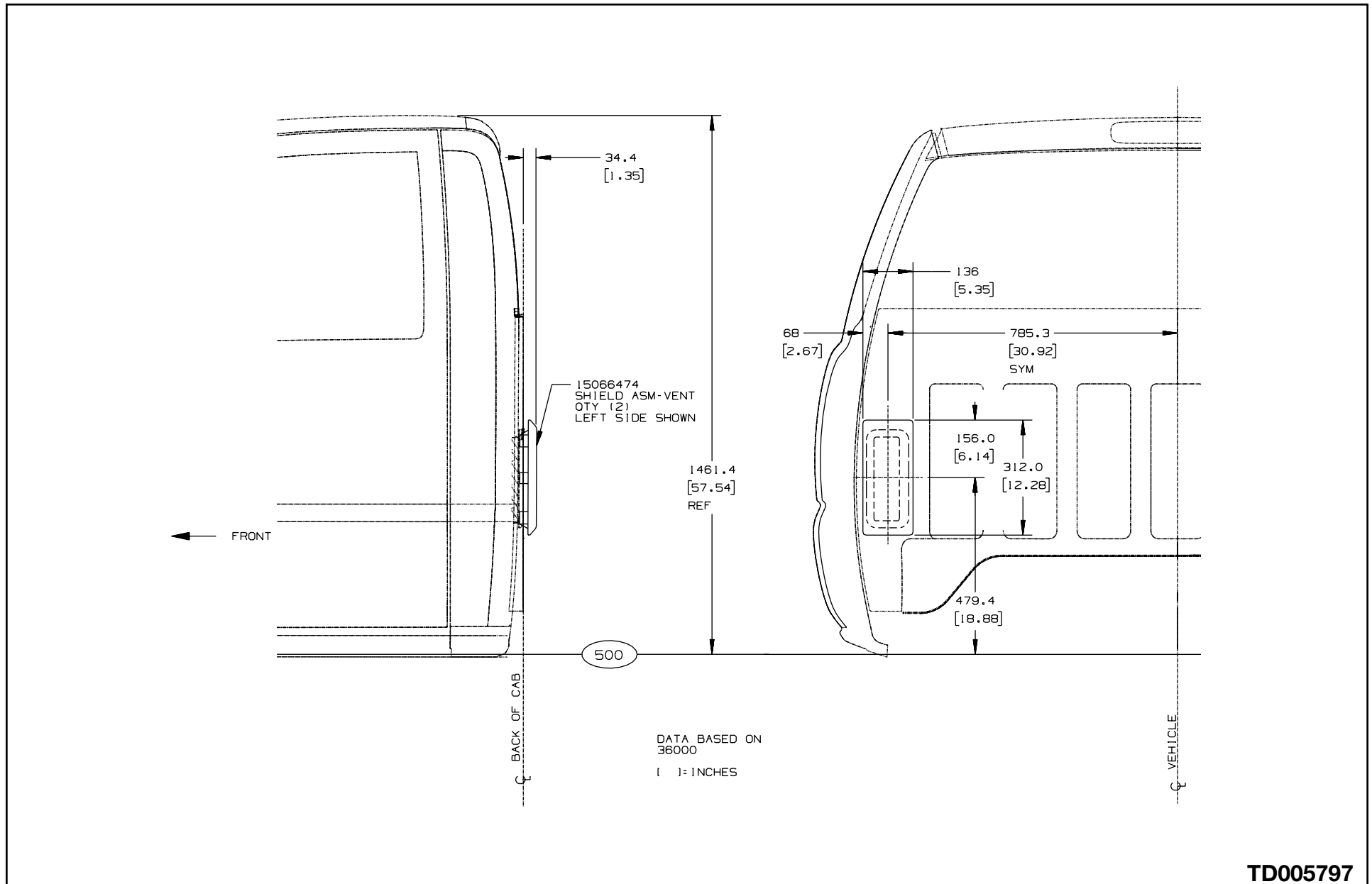

C/K (15/25) Front Floor Seat Mounting Location

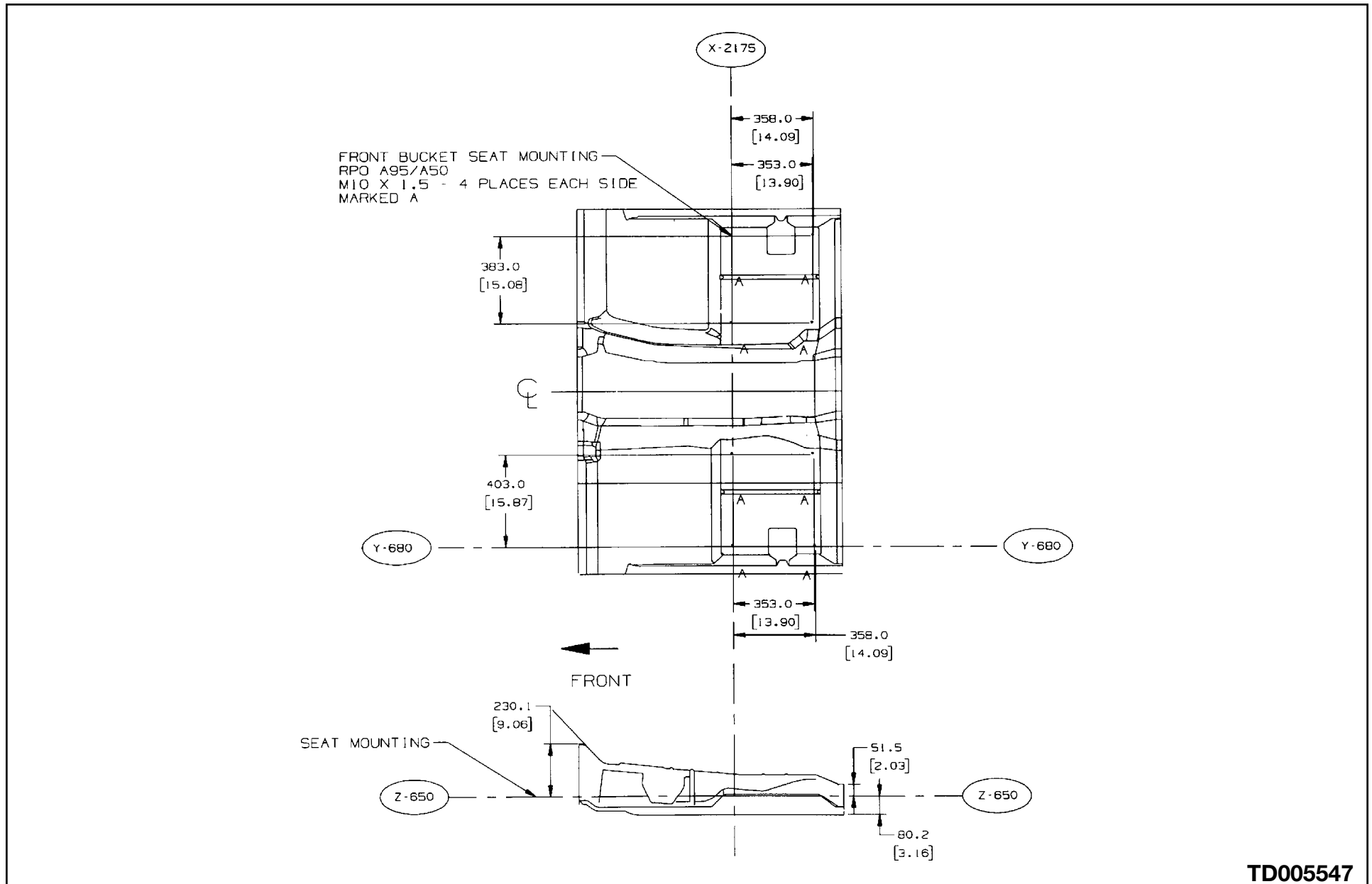

C/K (25HD/35/36) Front Floor Seat Mounting Location

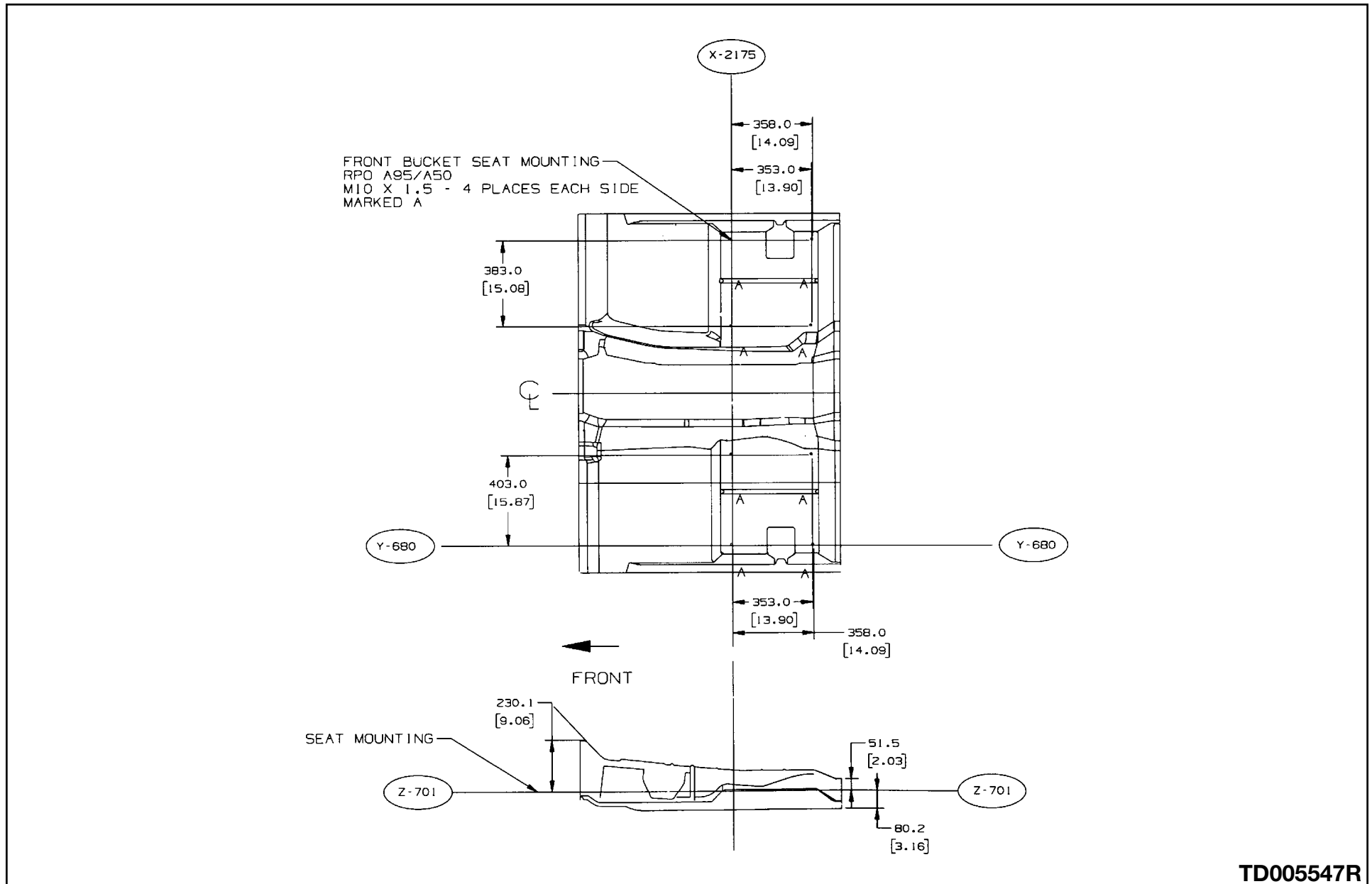

C/K (25HD/35/36) Front Floor Structure

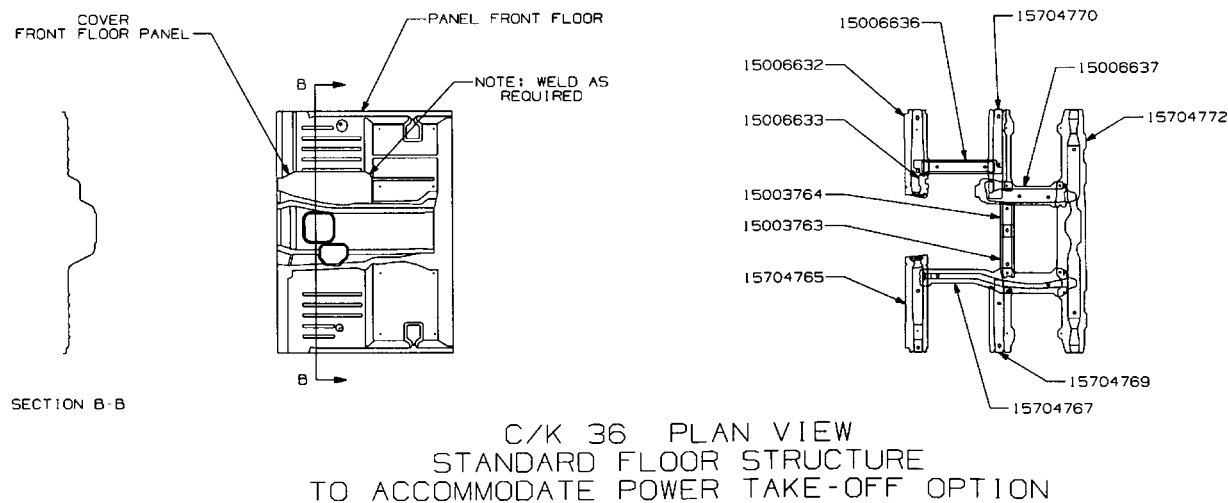
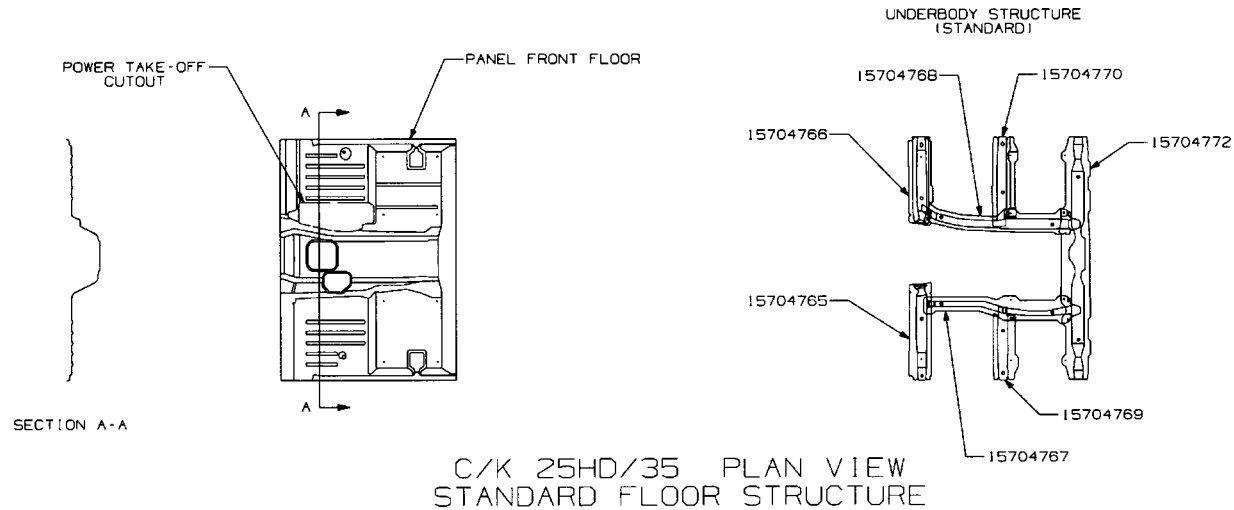

TD005582

C 15703 Rail and Crossmember Arrangement

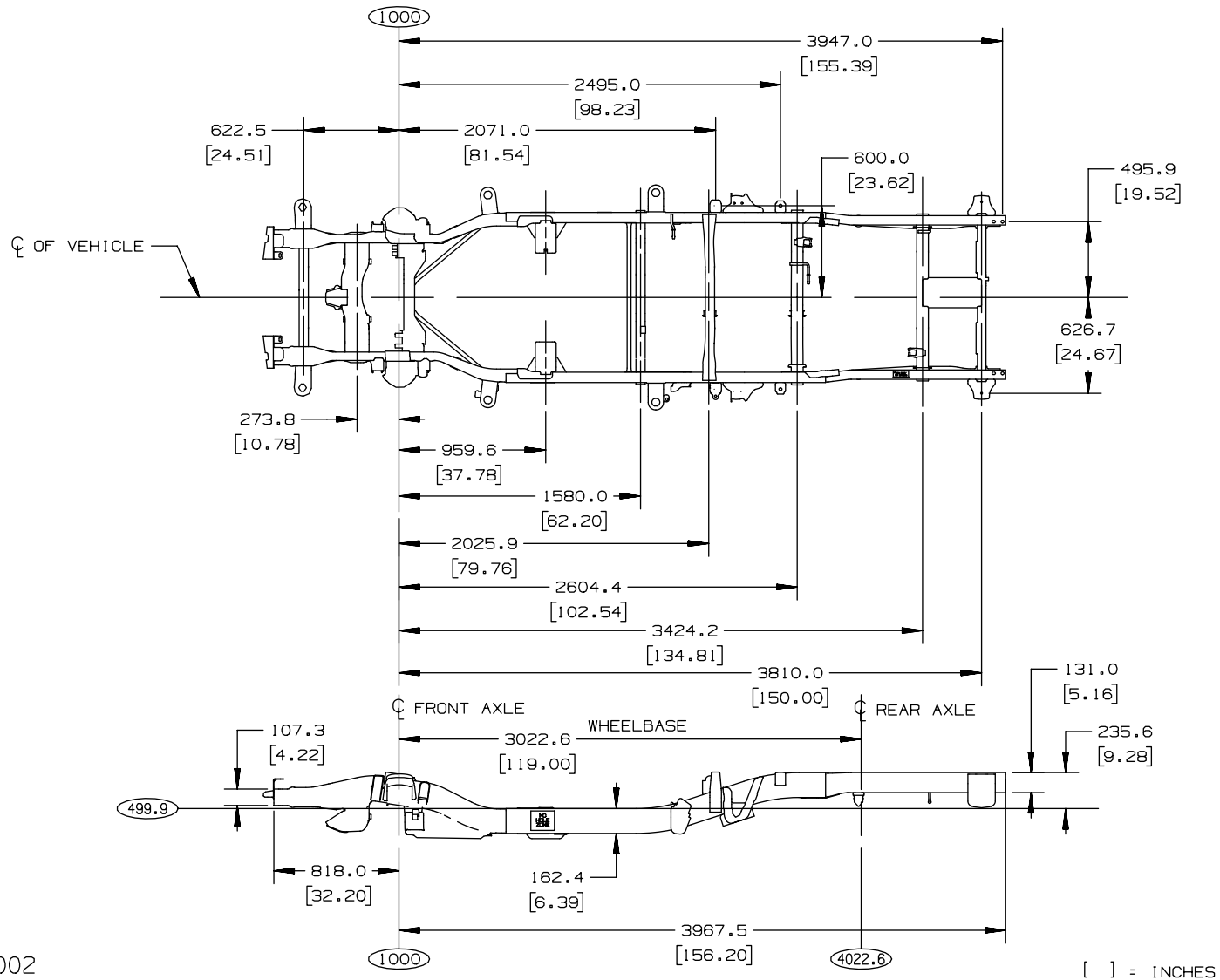

C15703, 2002

[] = INCHES

TD05970a

K 15703 Rail and Crossmember Arrangement

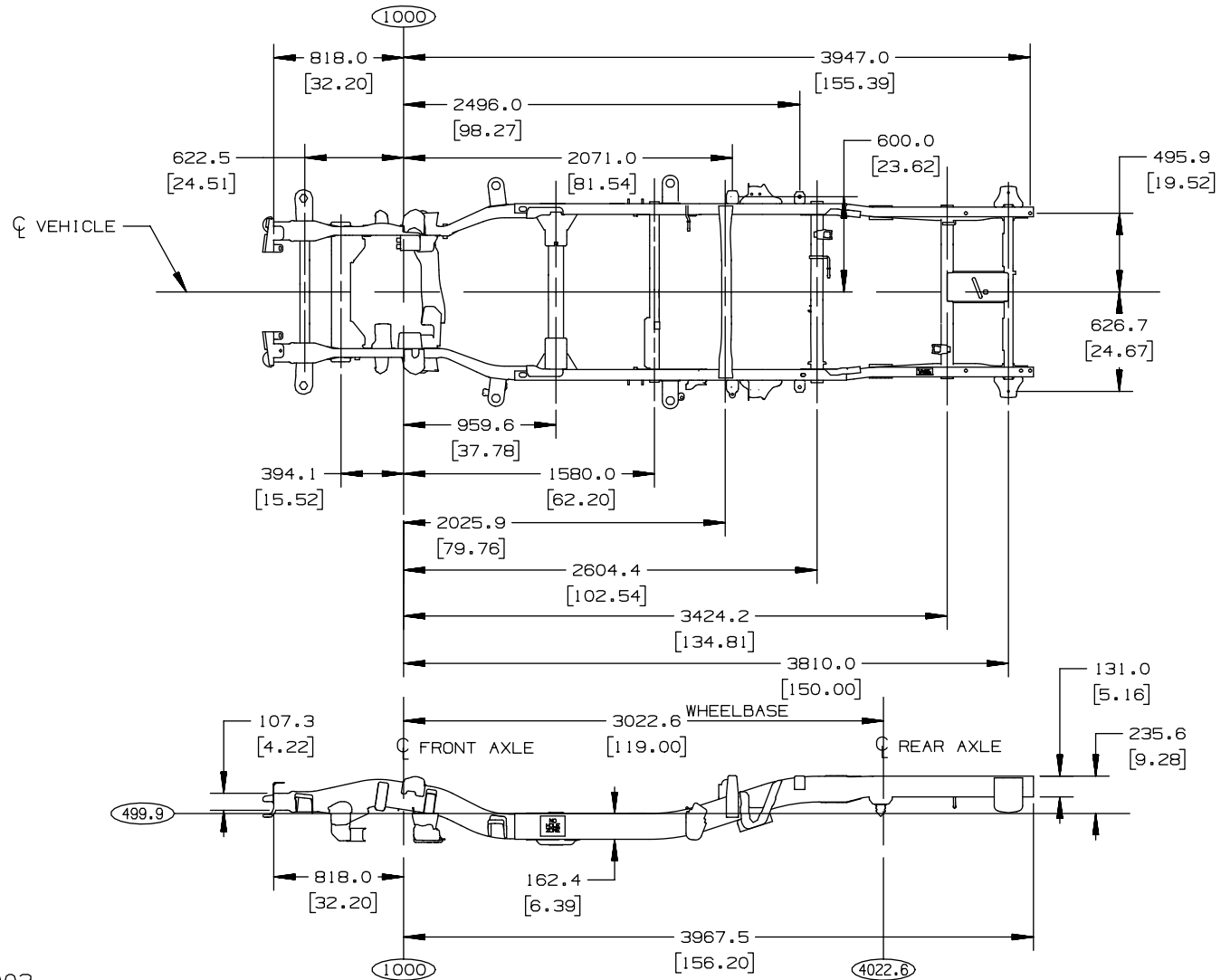

K15703, 2002

[] = INCHES

TD005970b

C 15903 Rail and Crossmember Arrangement

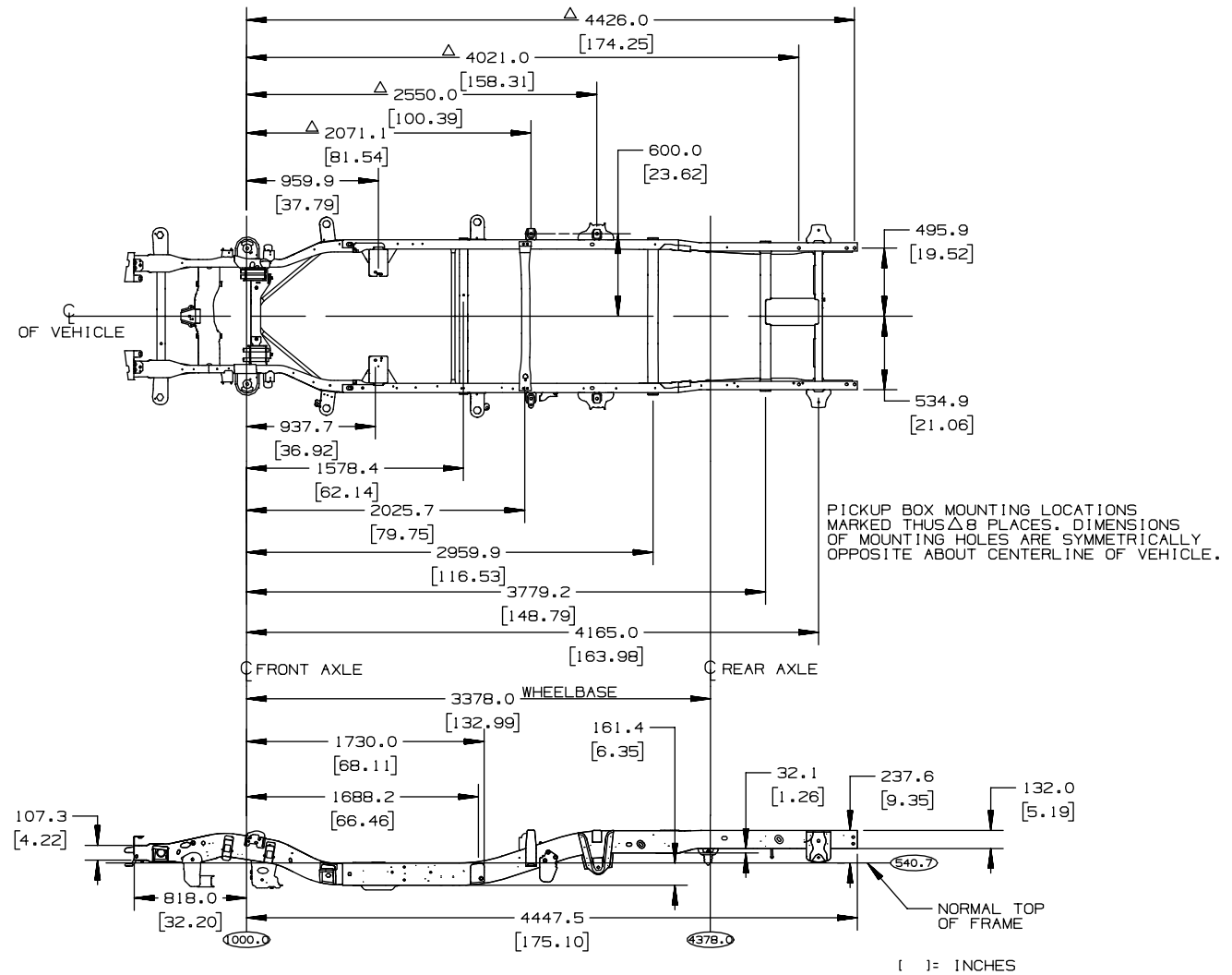

GMT 800, C15903, 2002

TD005973a

K 15903 Rail and Crossmember Arrangement

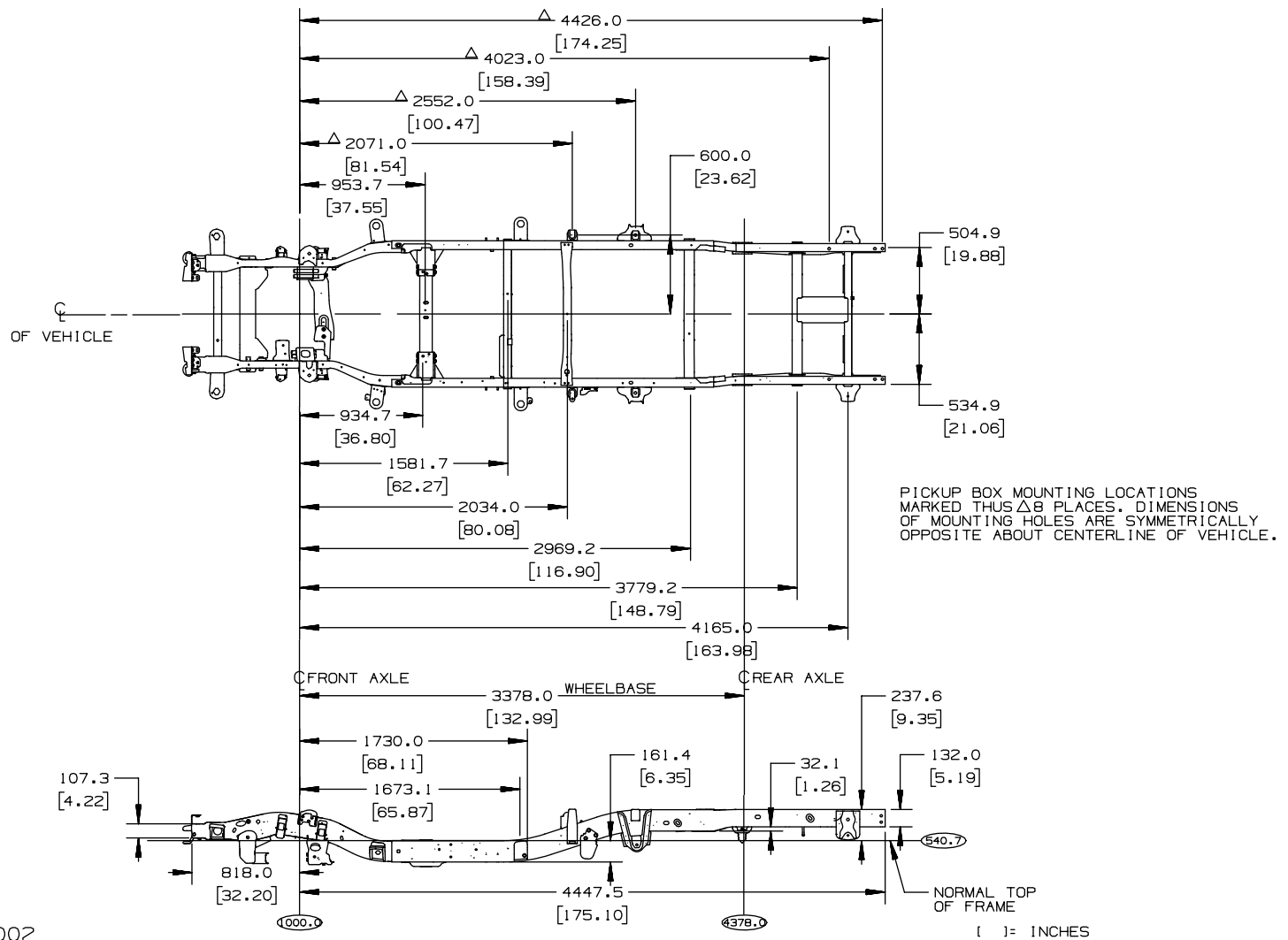

GMT 800, K 15903, 2002

TD005973b

C/K 25903 Rail and Crossmember Arrangement

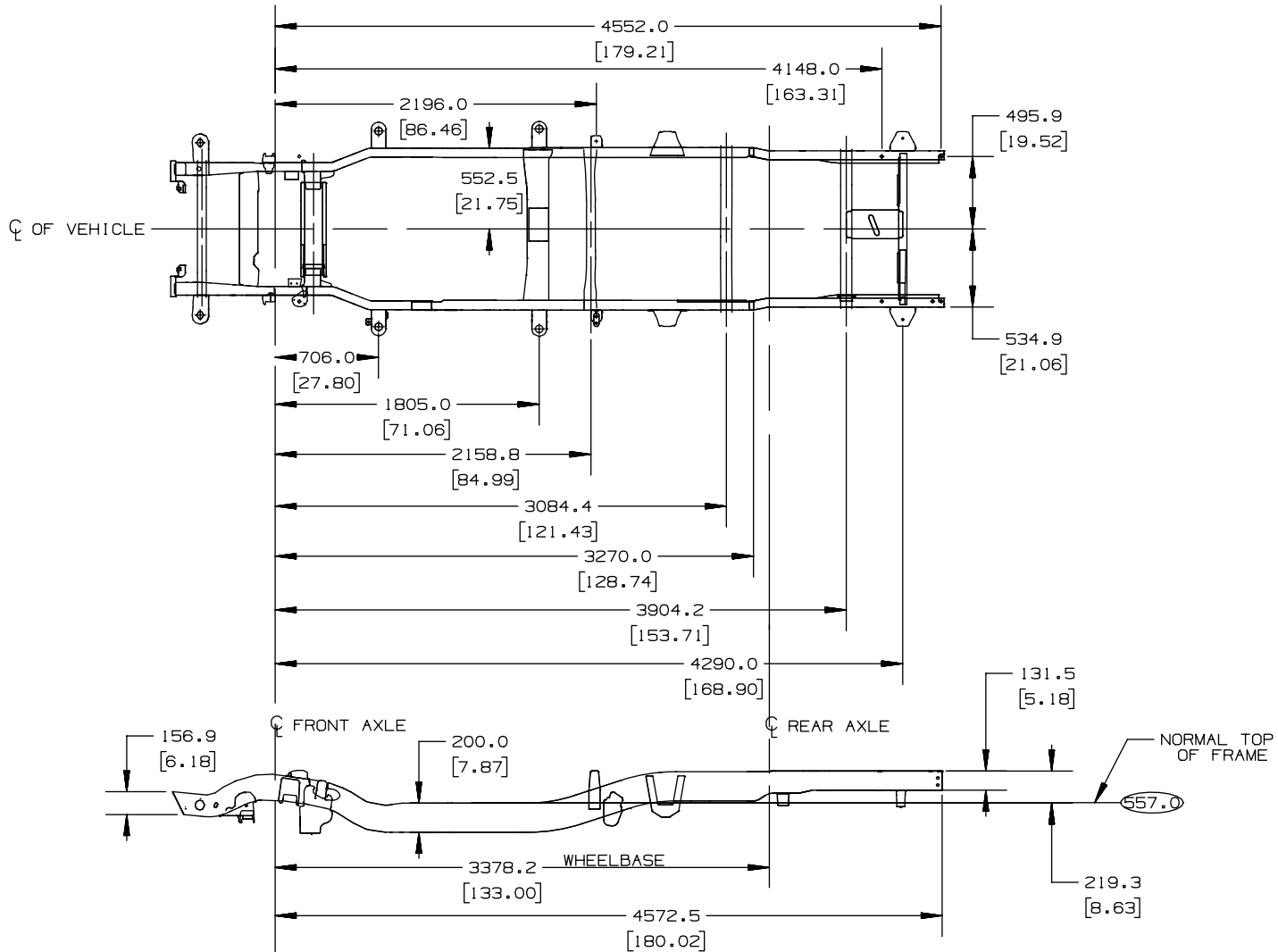

C/K 259/03 RAIL AND CROSSMEMBER ARRANGEMENT 2002

[] = INCHES

TD005976

C 15753 Rail and Crossmember Arrangement

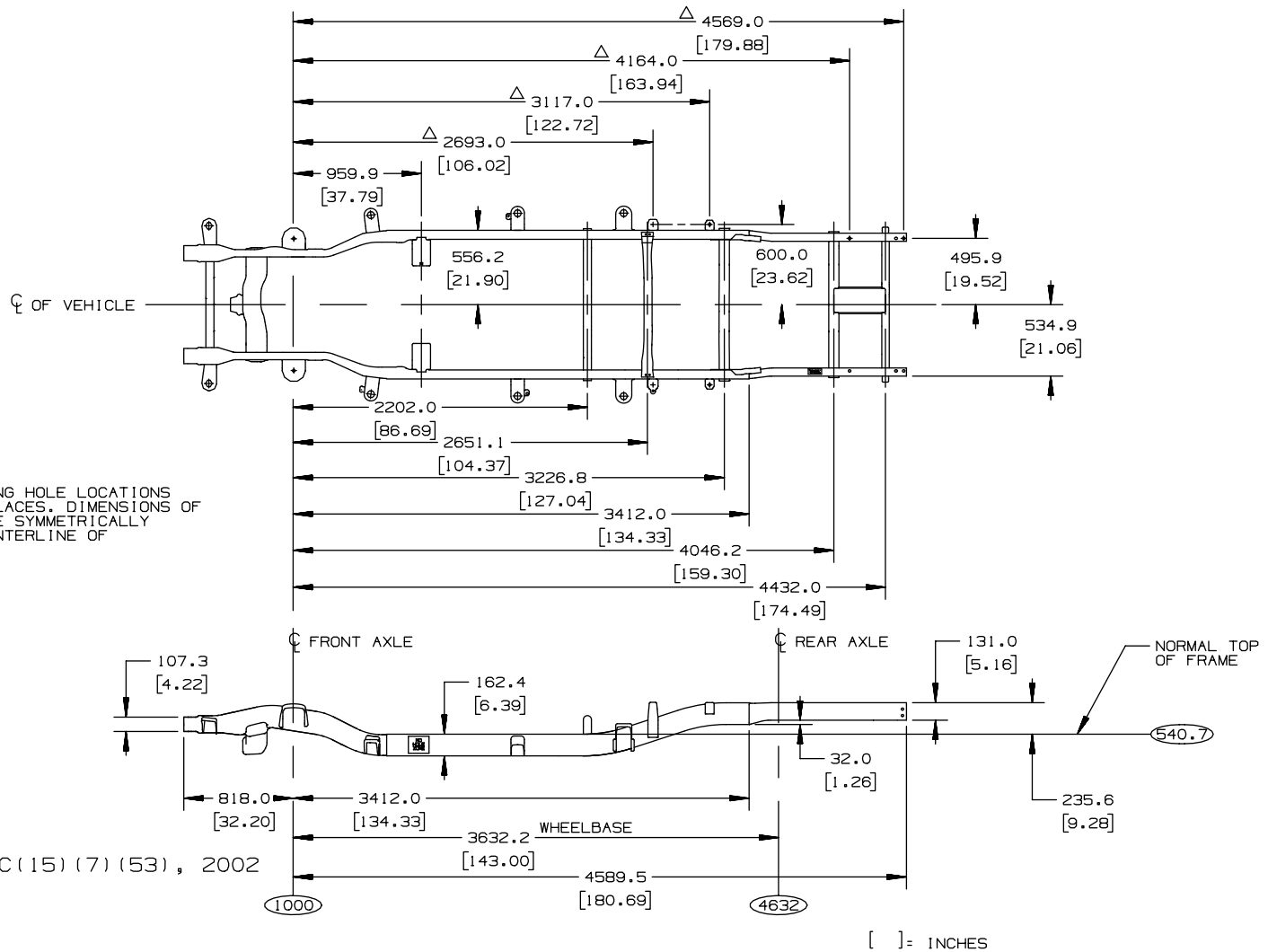

TD005972a

K 15753 Rail and Crossmember Arrangement

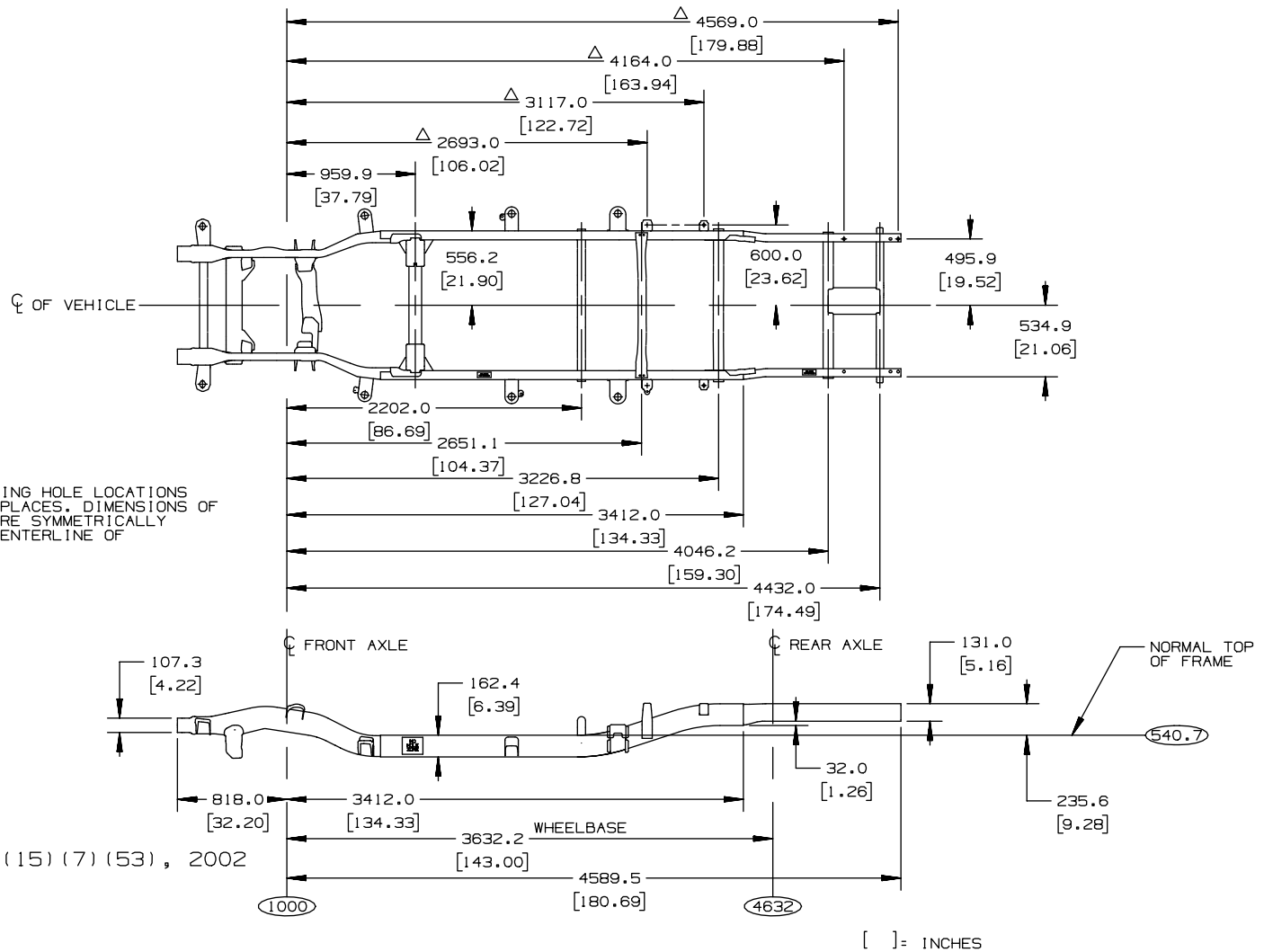

TD005972b

C 15953 Rail and Crossmember Arrangement

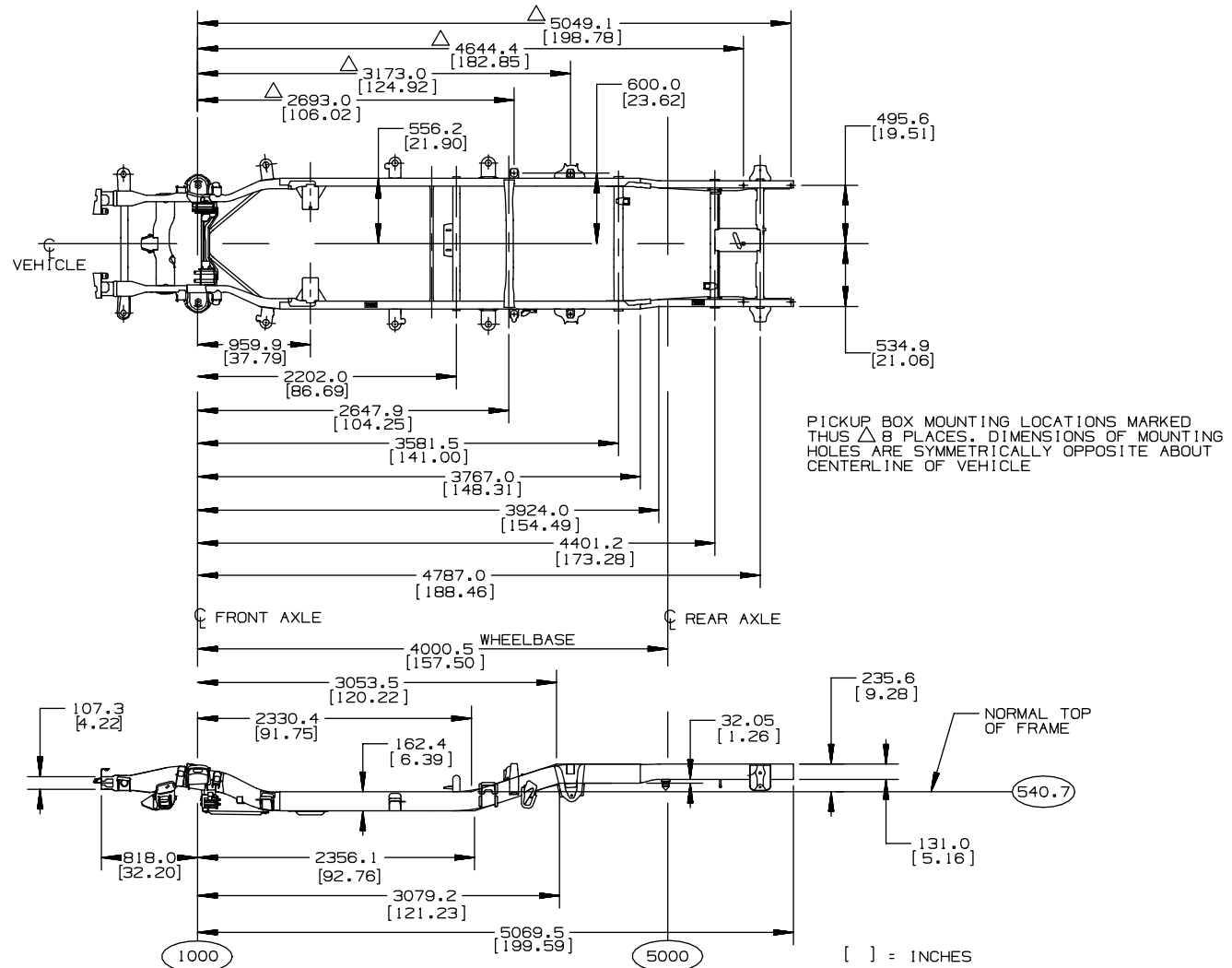

FRAME & CROSSMEMBER
GMT 800, C15953

TD005974a

K 15953 Rail and Crossmember Arrangement

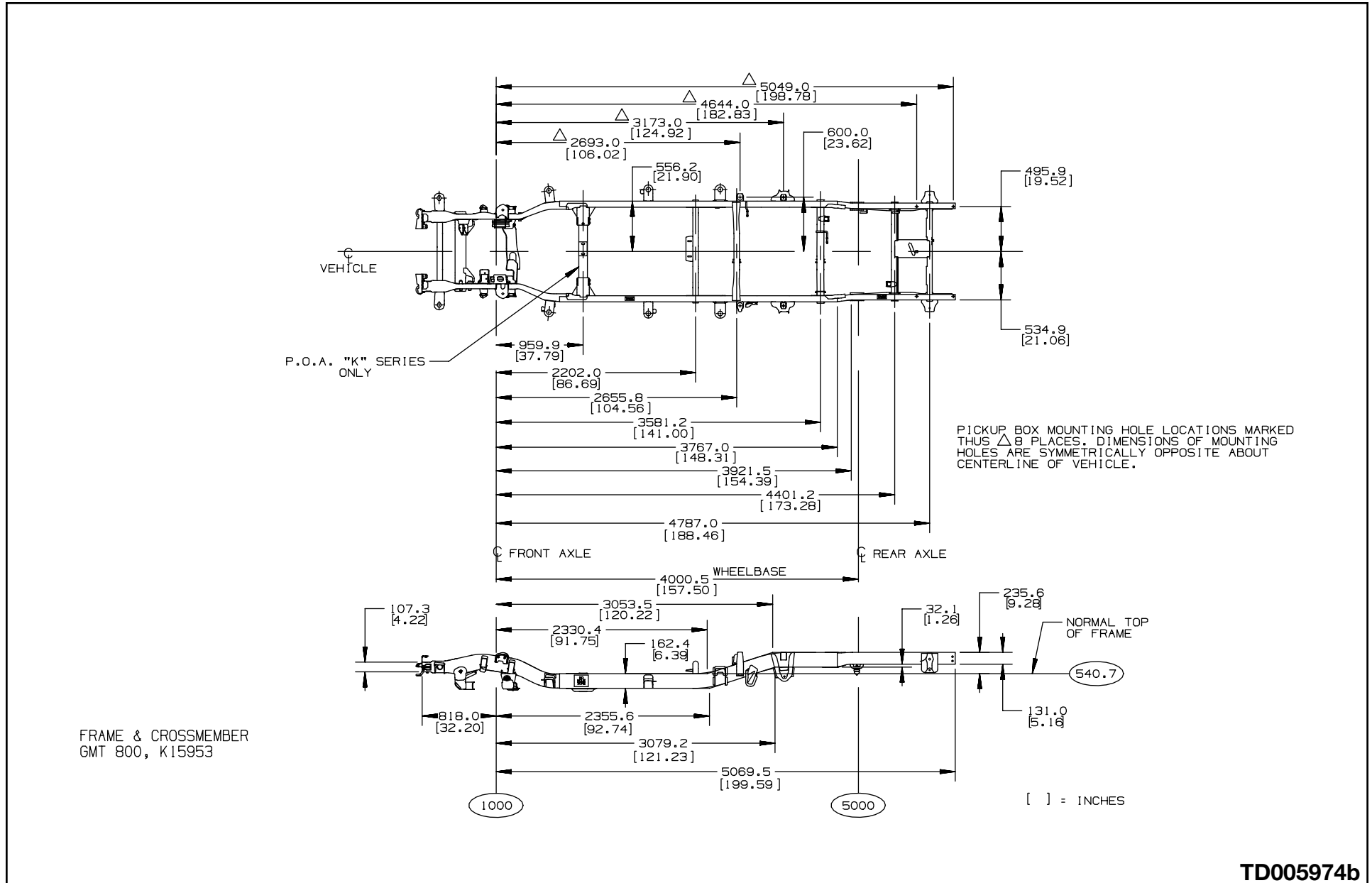

C 15543 Rail and Crossmember Arrangement

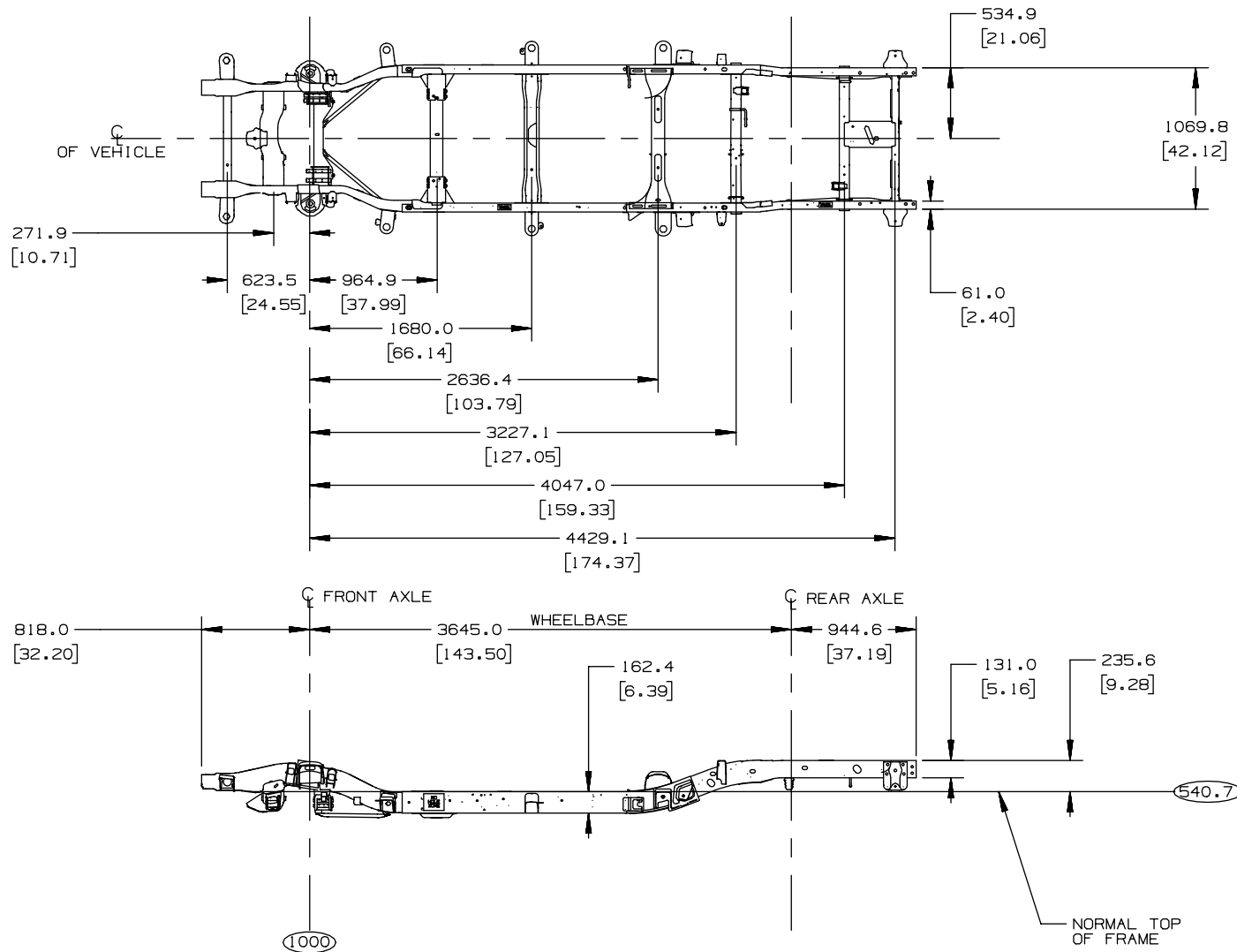

GMT 800, C15543, 2004

[] = INCHES

TD006147a

K 15543 Rail and Crossmember Arrangement

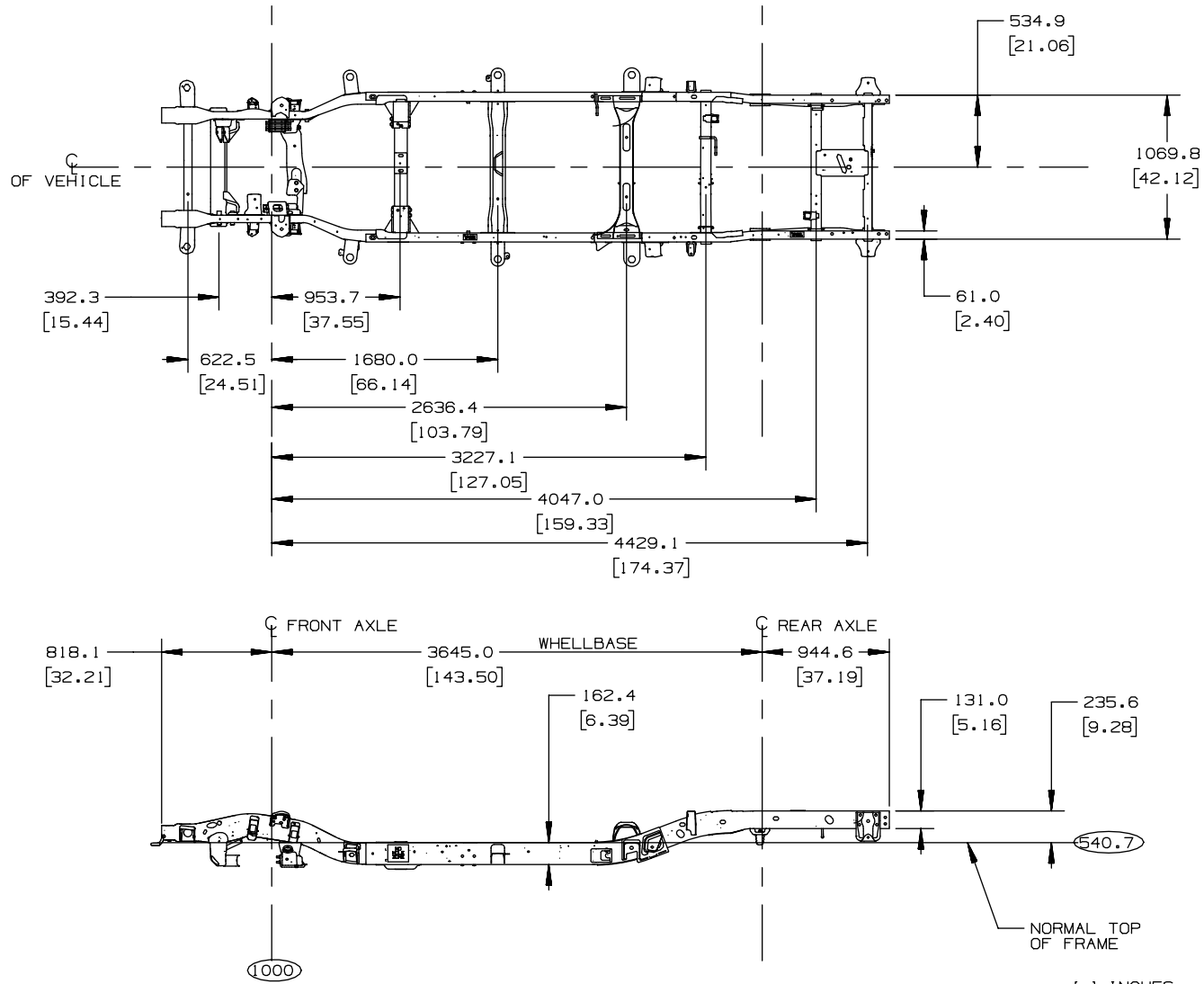

GMT 800, K15543, 2004

[] = INCHES

TD006147b

C/K 15706 Rail and Crossmember Arrangement

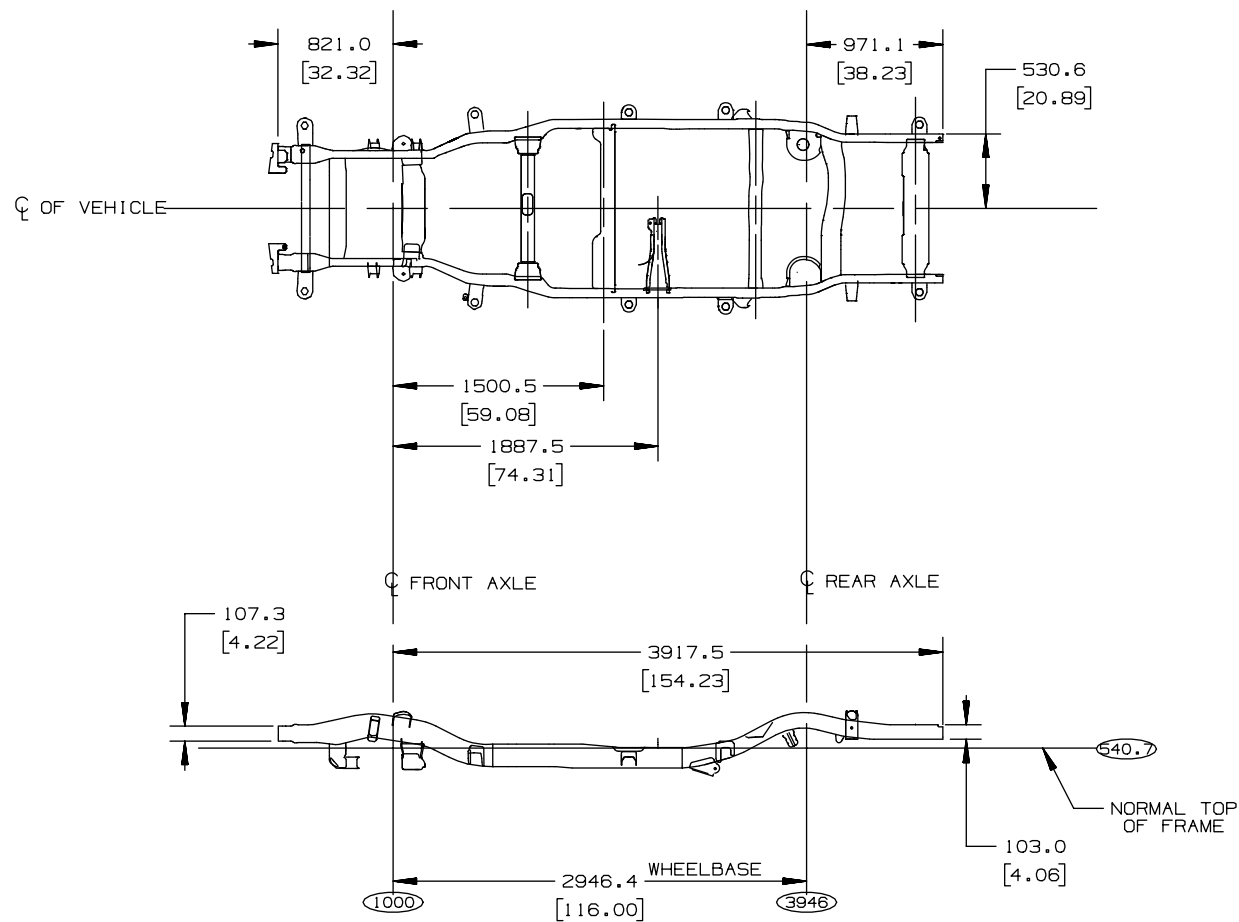

C/K 15706 RAIL AND CROSSMEMBER ARRANGEMENT 2002

[1]=INCHES

TD005981a

C/K 15906 Rail and Crossmember Arrangement

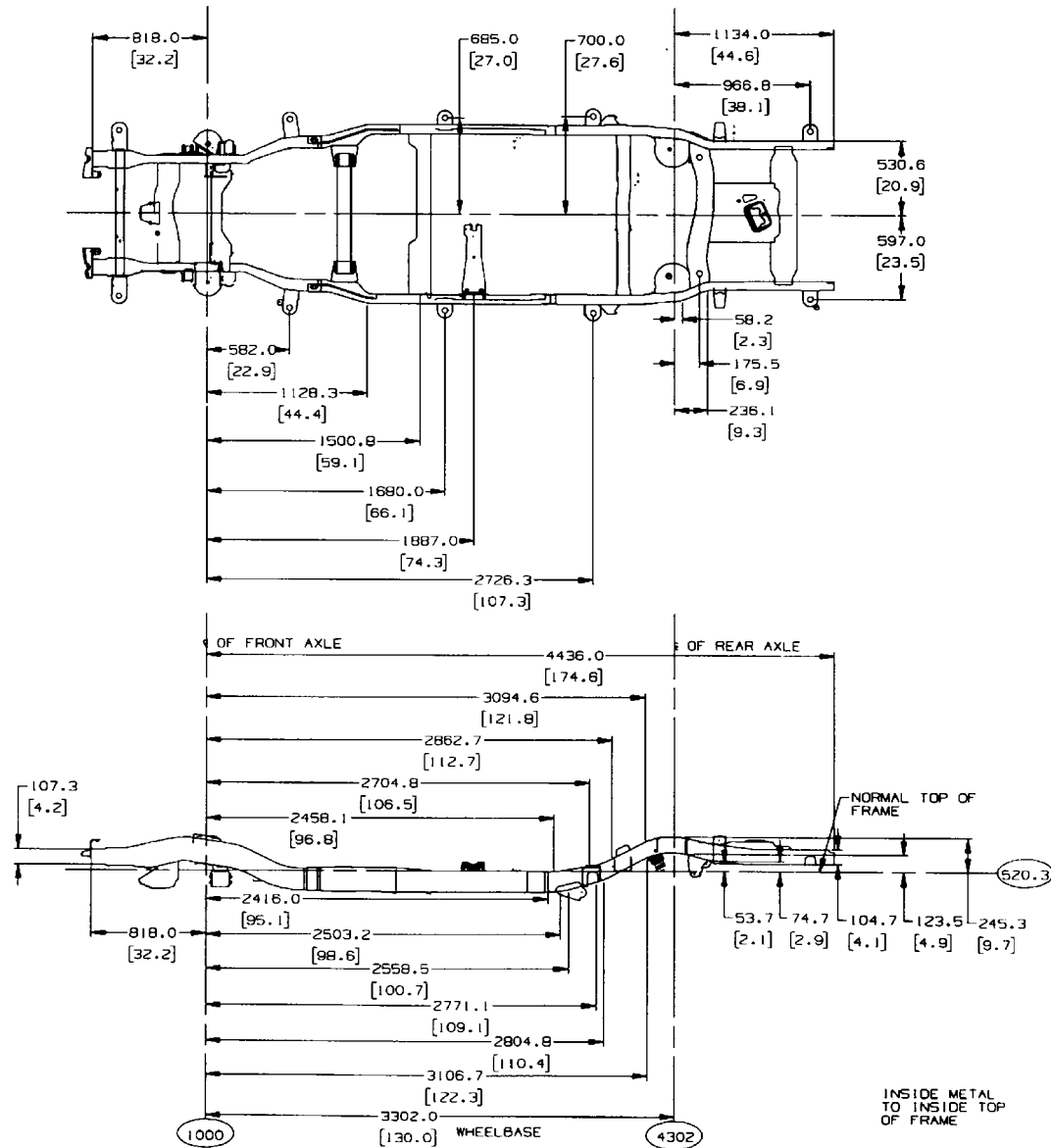

TD005348

C/K 25906 Rail and Crossmember Arrangement

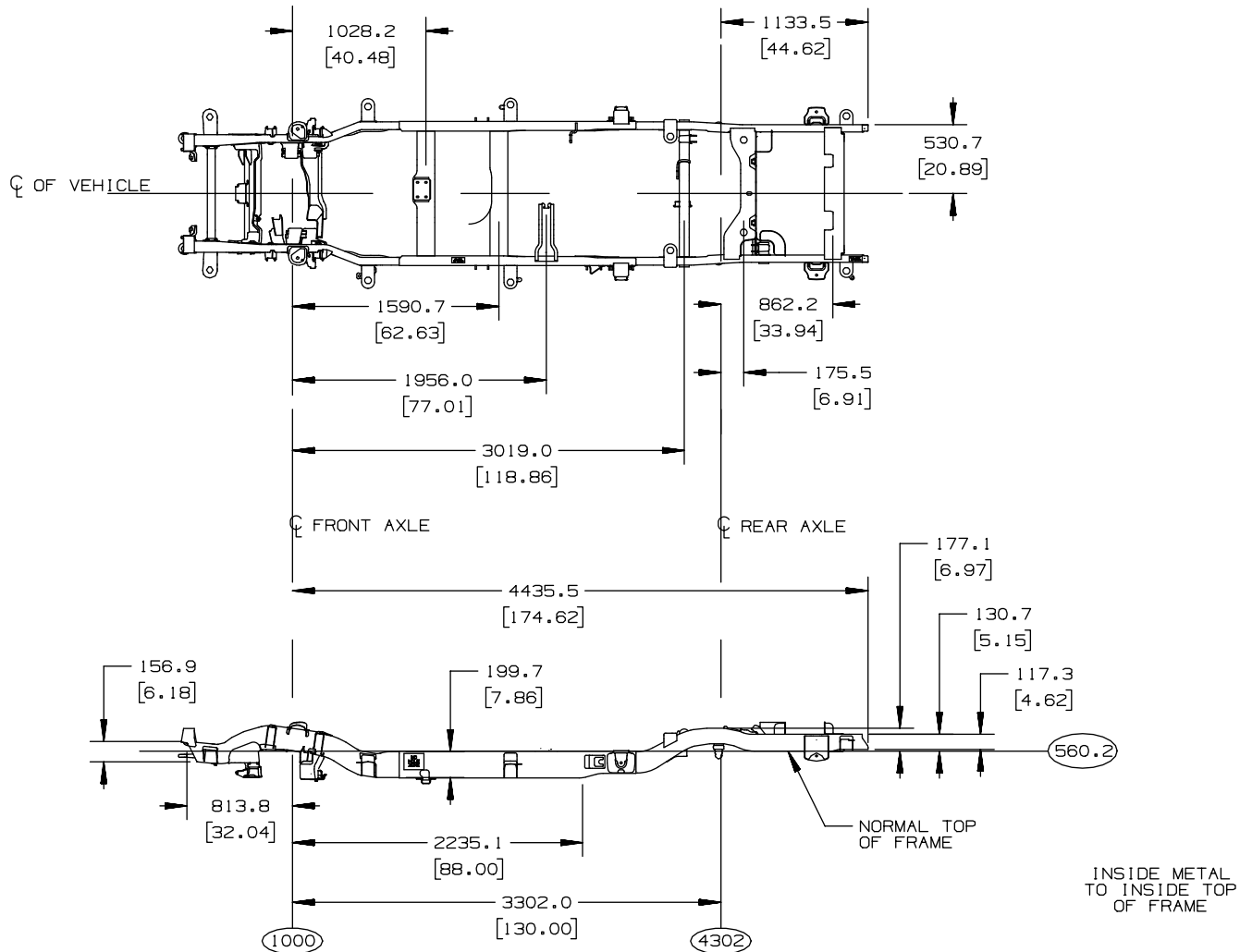

C/K 25906 RAIL & CROSSMEMBER ARRANGEMENT

[] = INCHES

C/K 25936 Rail and Crossmember Arrangement

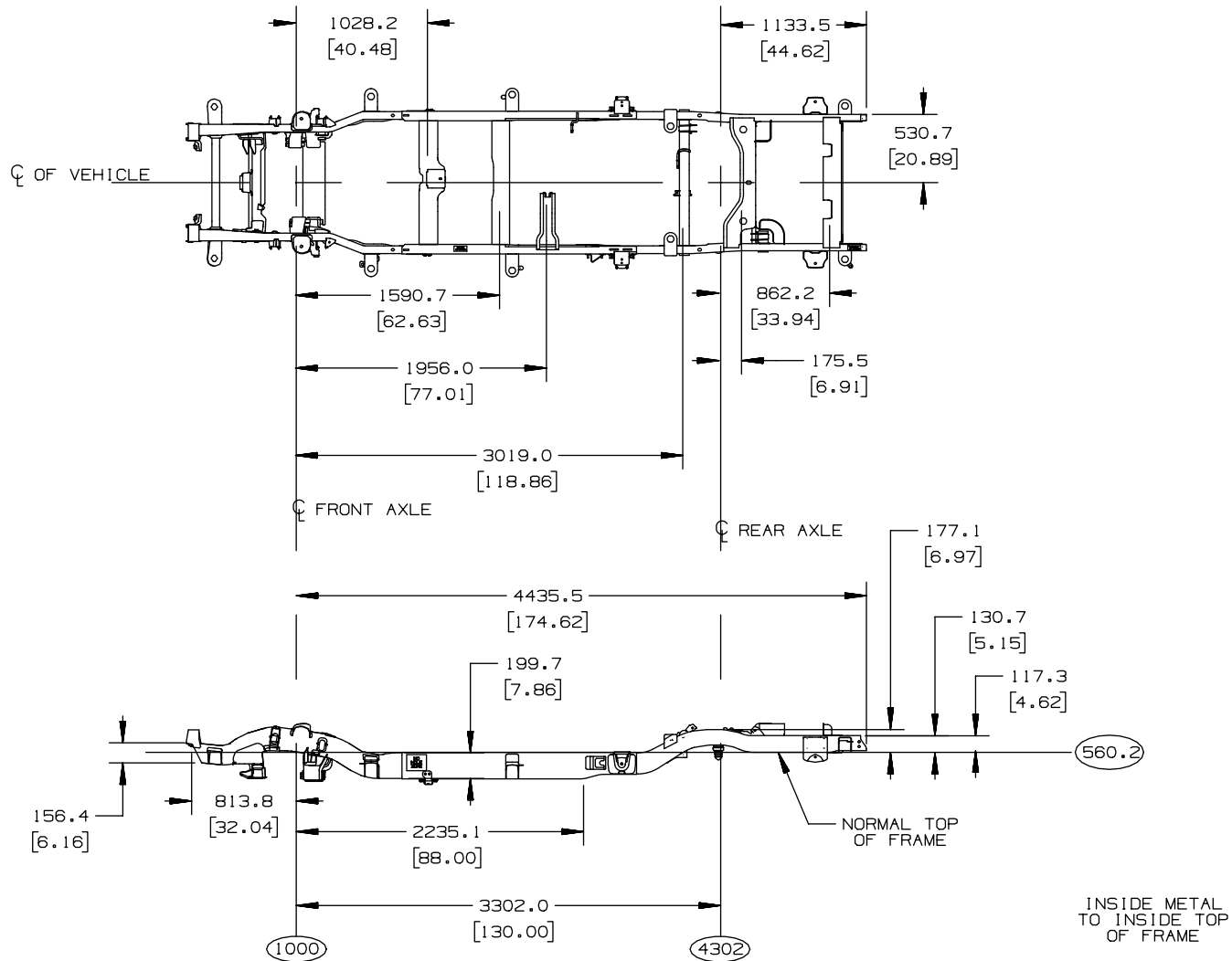

C/K 25936 RAIL & CROSSMEMBER ARRANGEMENT

[] = INCHES

C/K 25753 Rail and Crossmember Arrangement

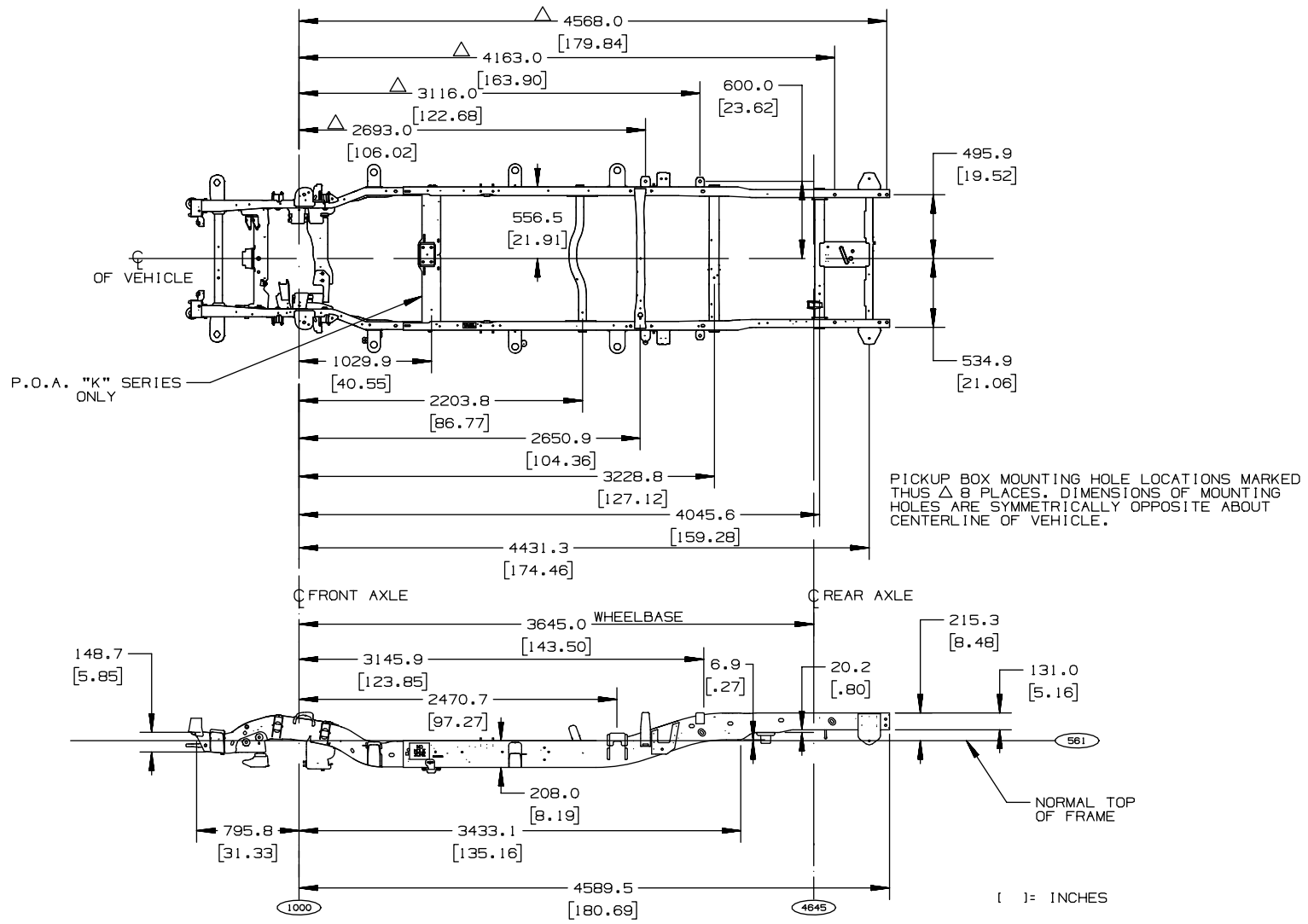

15063958 GMT800 K (257-53), 2002

TD005975a

C/K 25953 Rail and Crossmember Arrangement

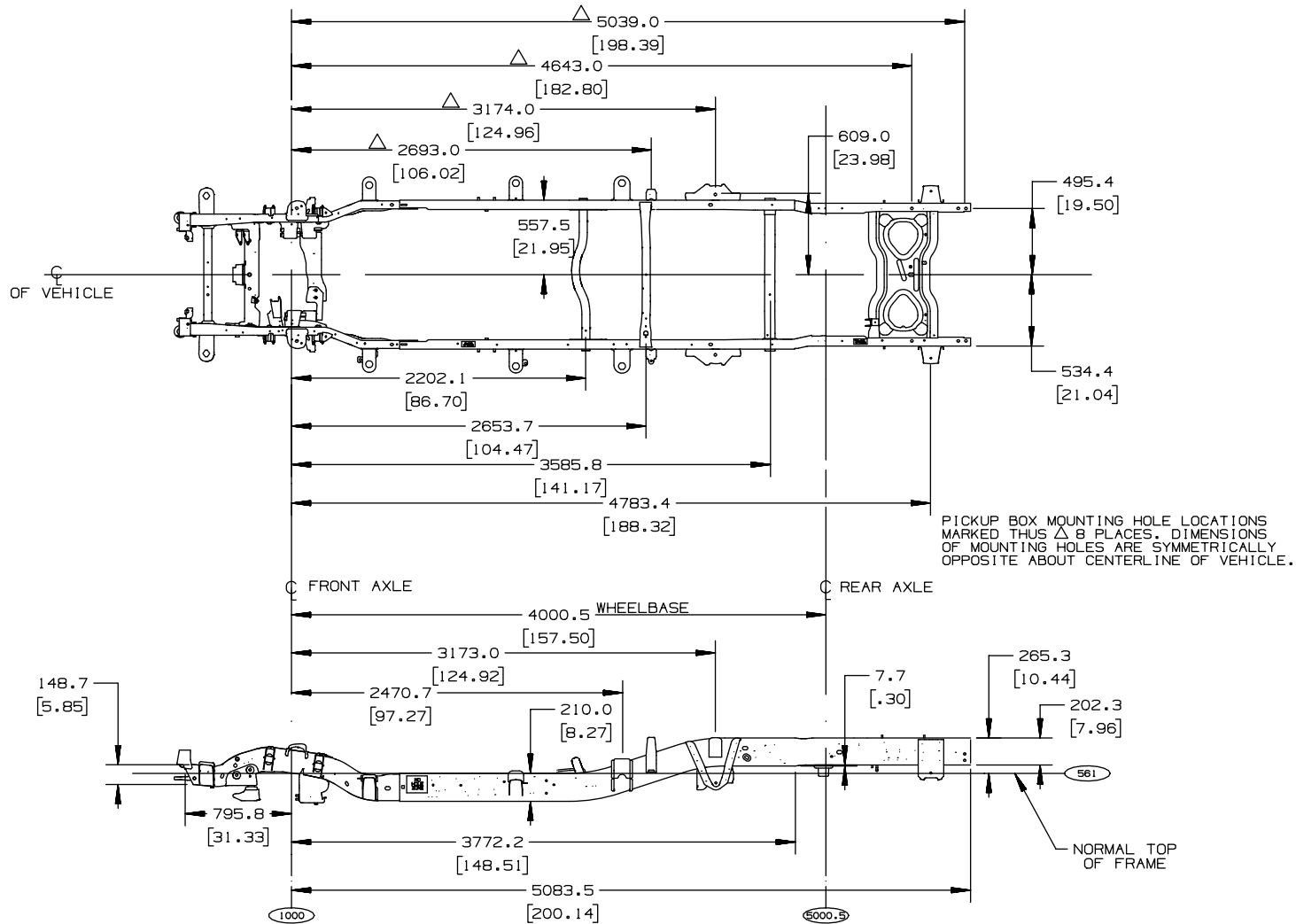

15077437 GMT800 K (259, 359-53), 2002

TD005975b

C (15) Front Frame Pickup

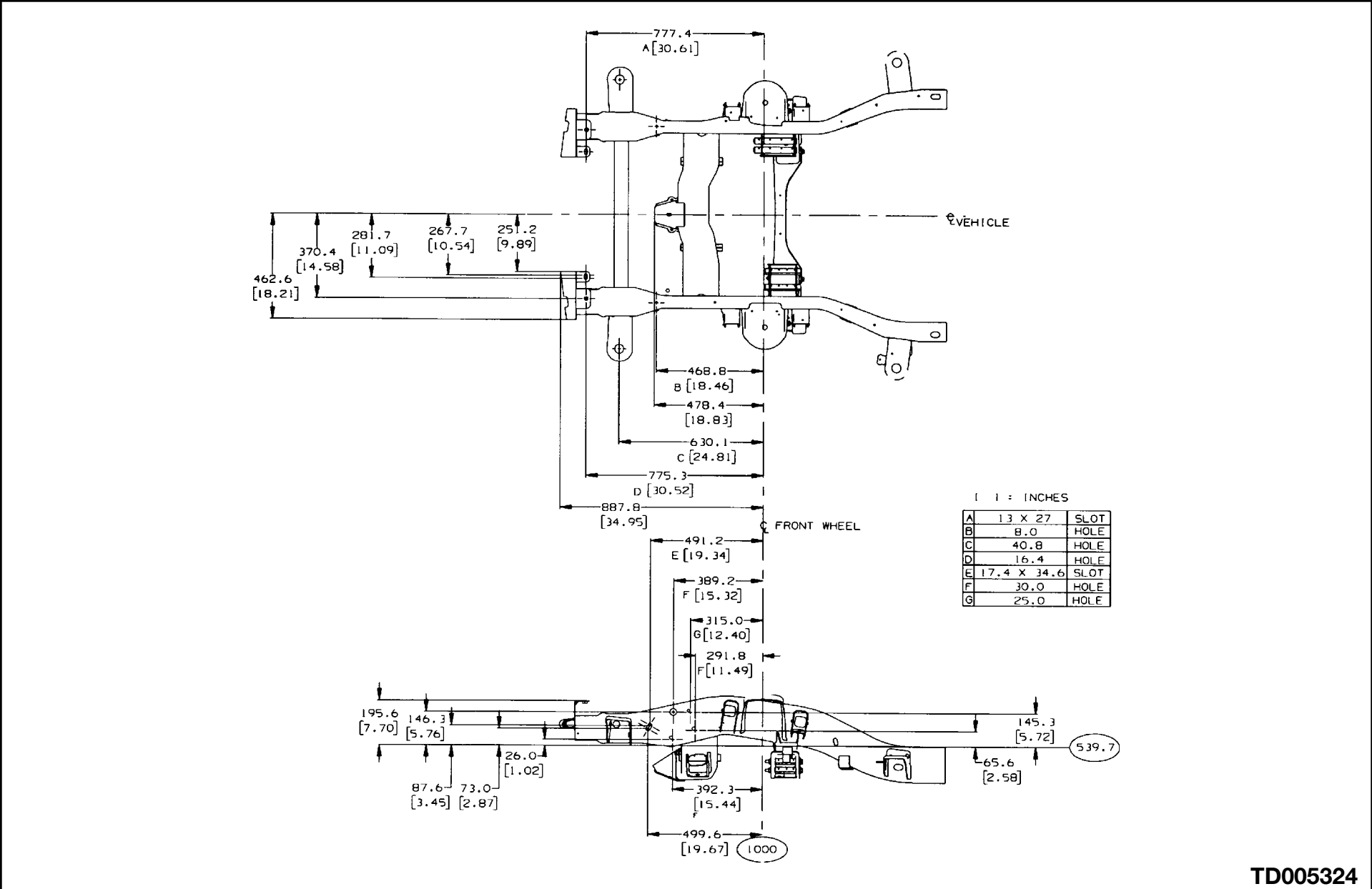

TD005324

C (25) Front Frame Pickup

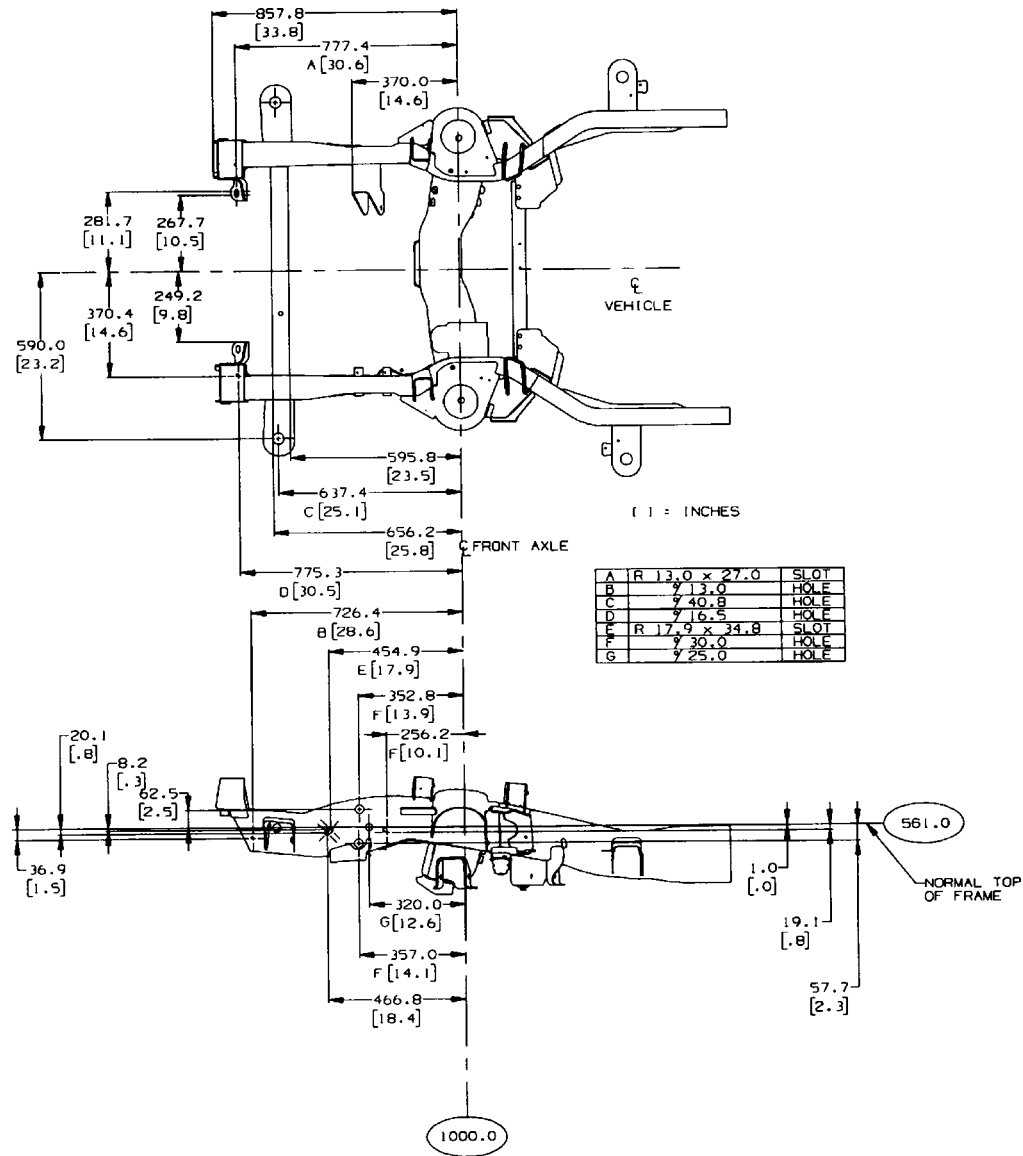

TD005323

K (15) Pickup C/K (15) Utility Front Frame

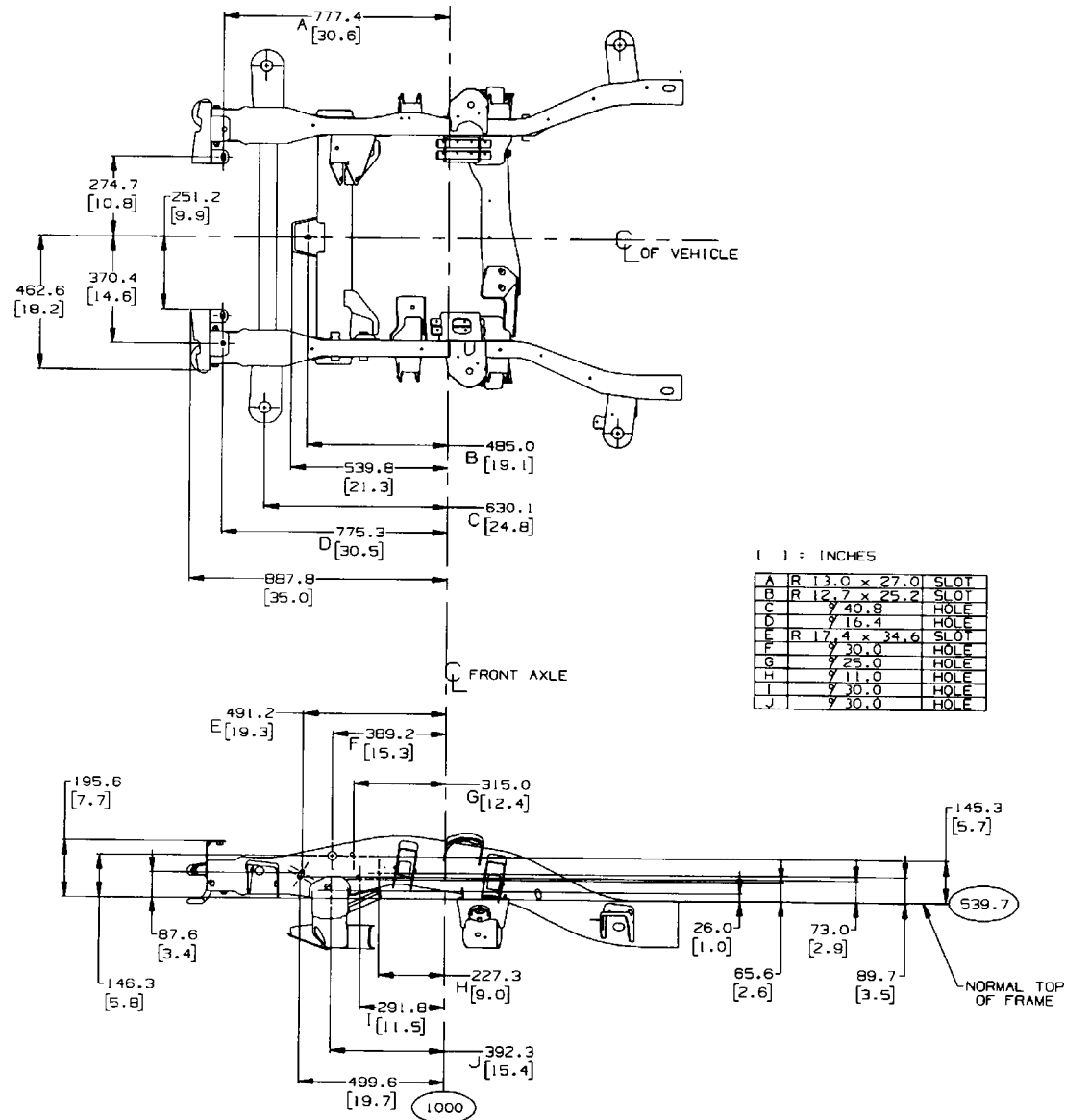

TD005325

K (25) Pickup C/K (25) Utility Front Frame

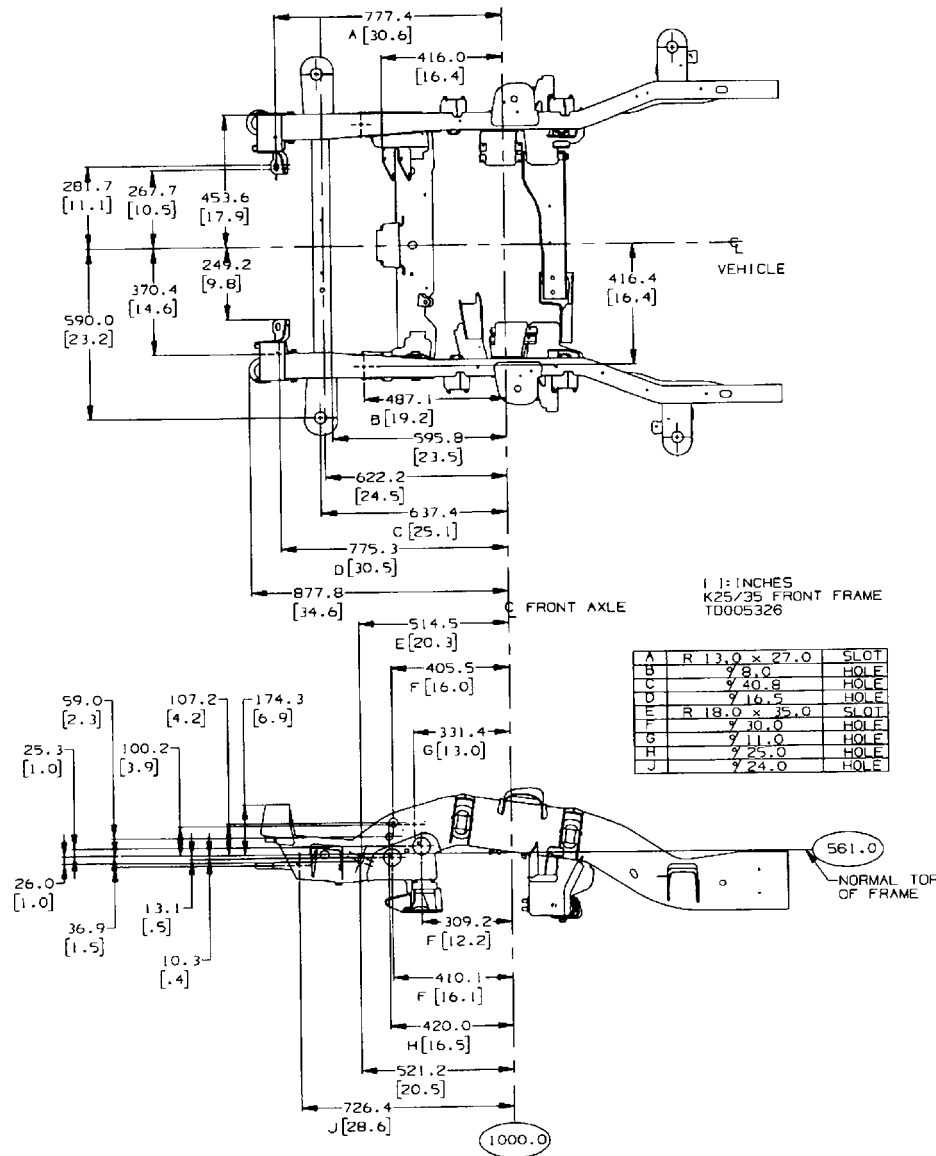

TD005326

C/K (25HD/35/36) Front Frame

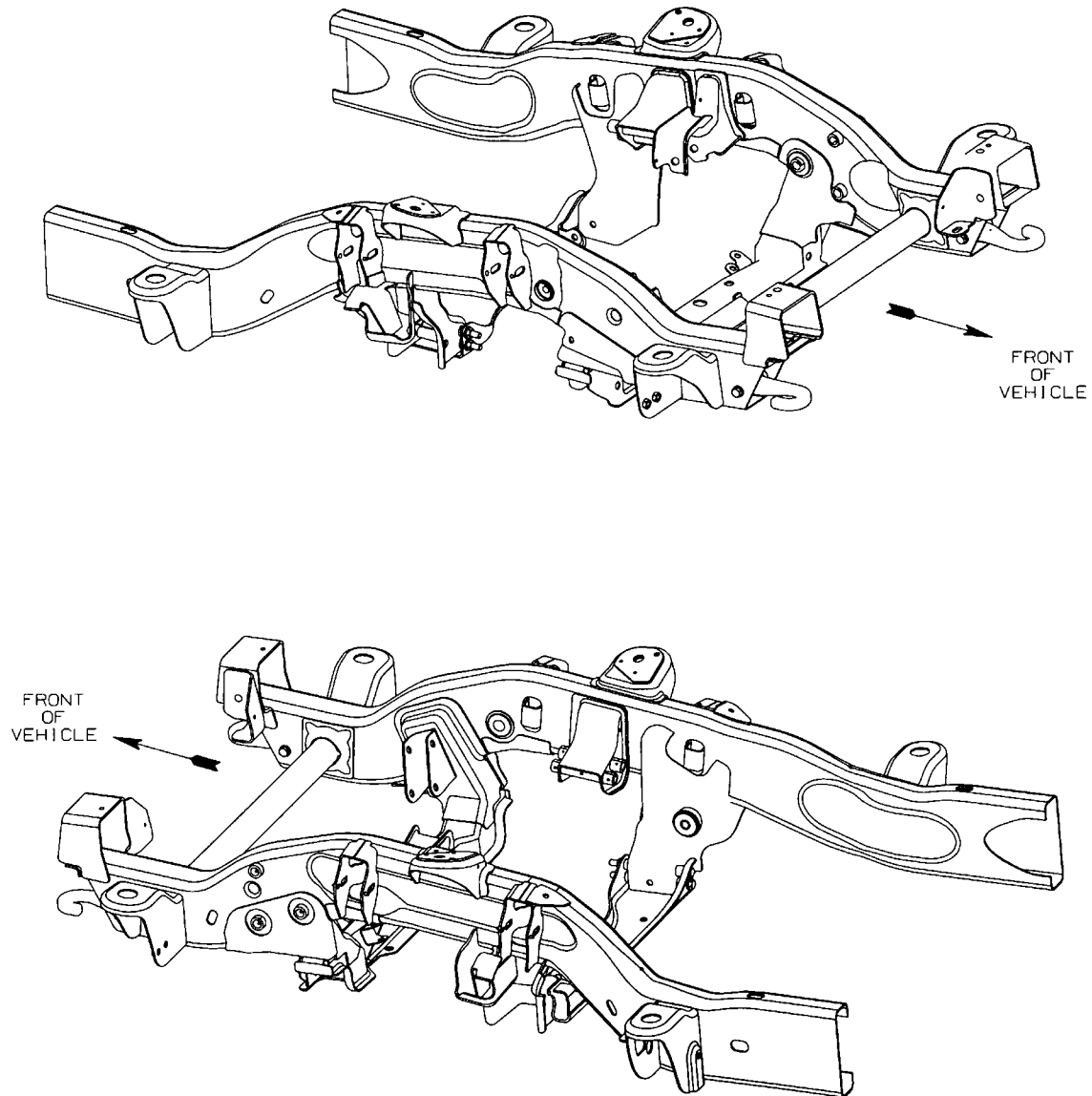

15753457

C (25HD/35/36) Front Frame W/Dim

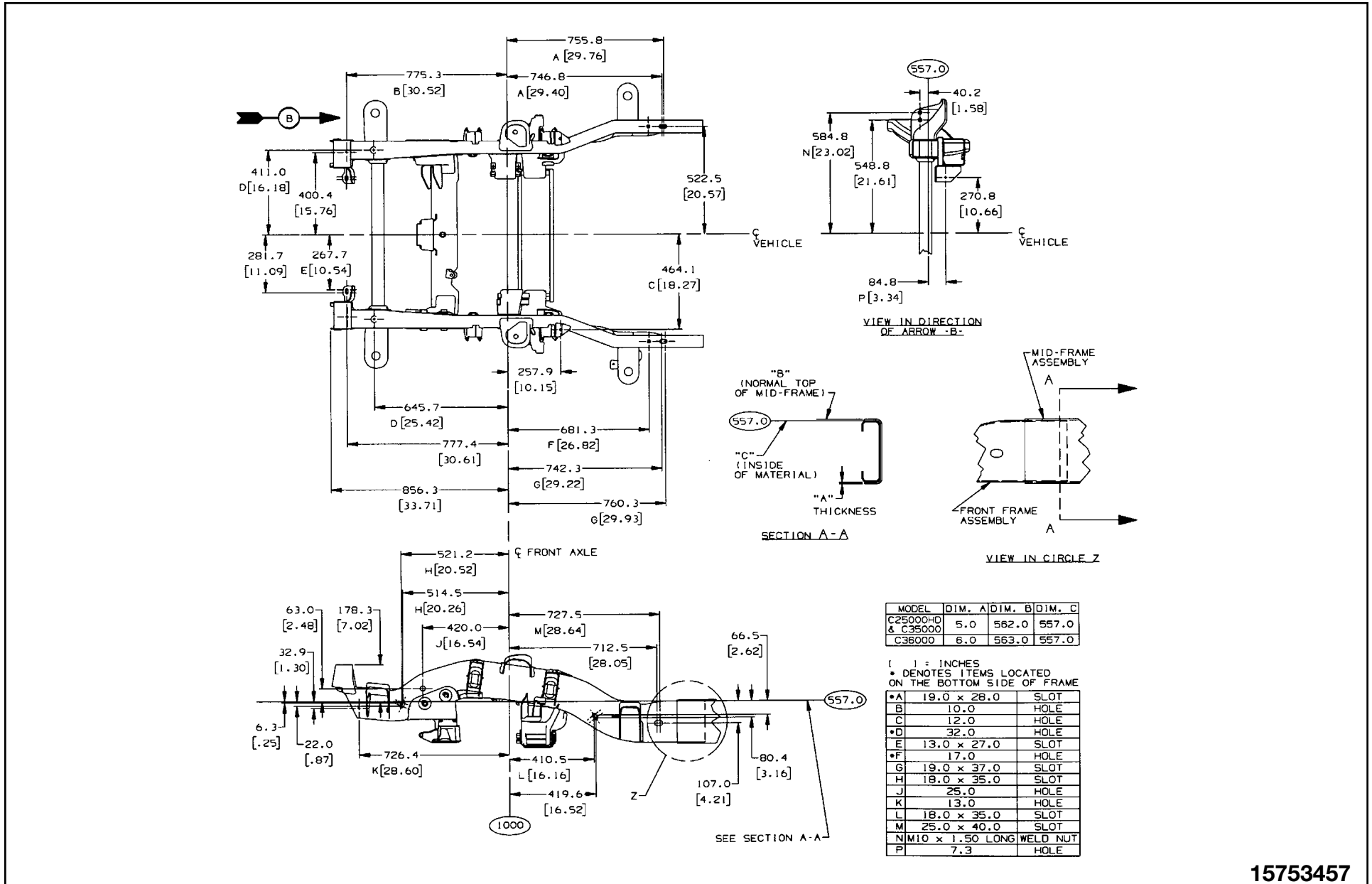

15753457

K (25HD/35/36) Front Frame W/Dim

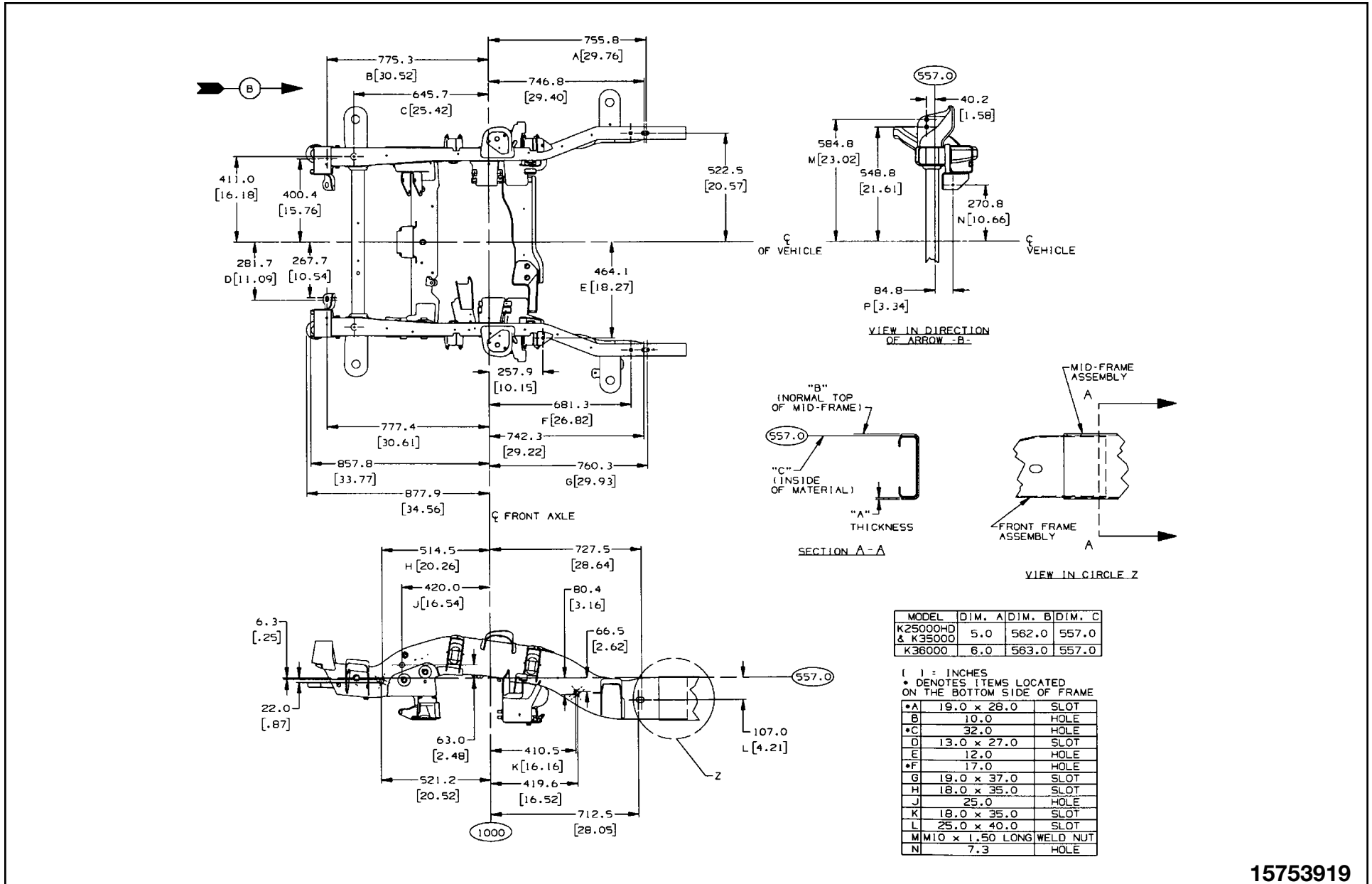

15753919

C/K (25HD/K35)903 Intermediate and Rear Frame

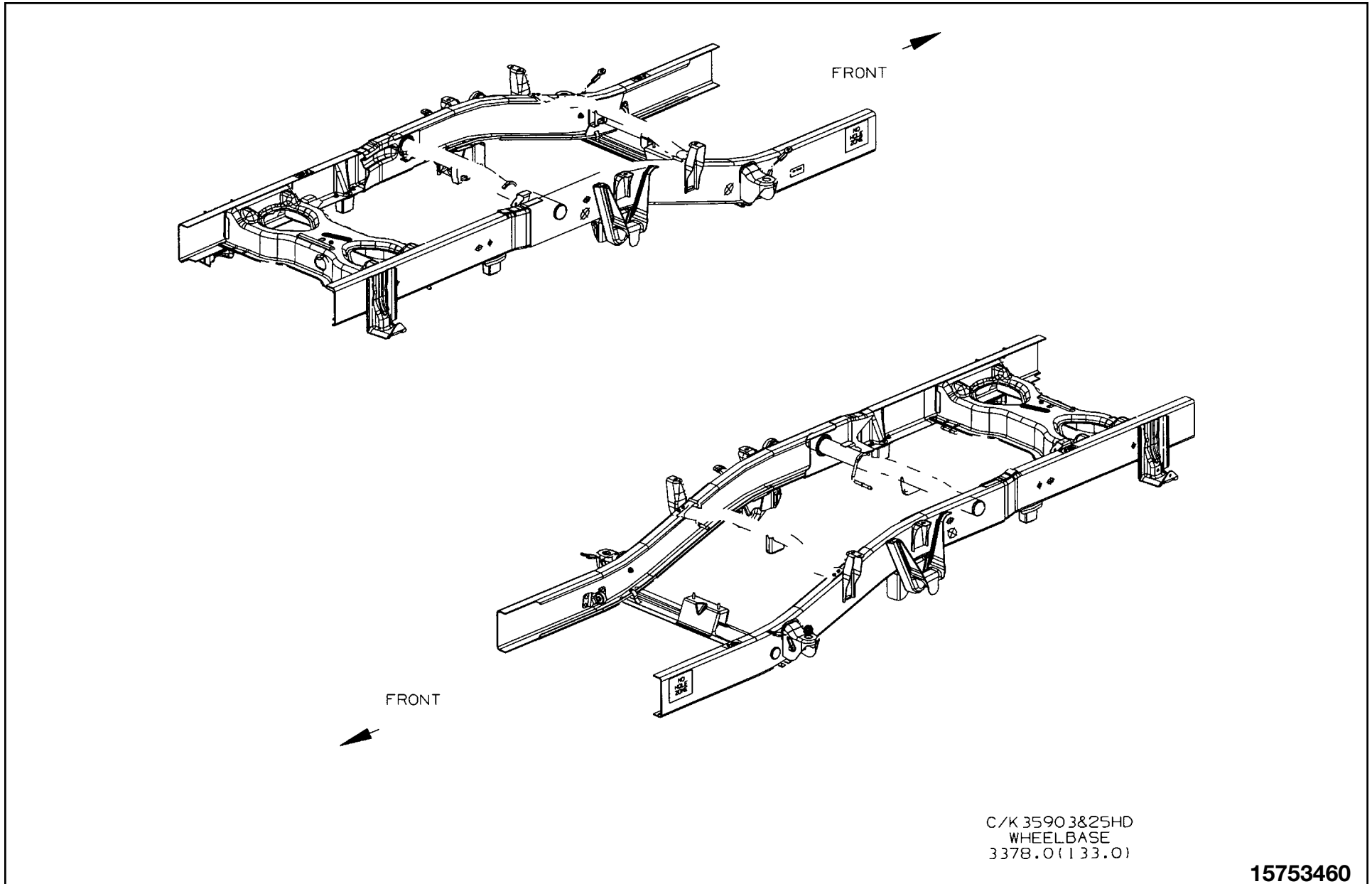

15753460

C/K (25HD/K35)903 Intermediate and Rear Frame W/Dim

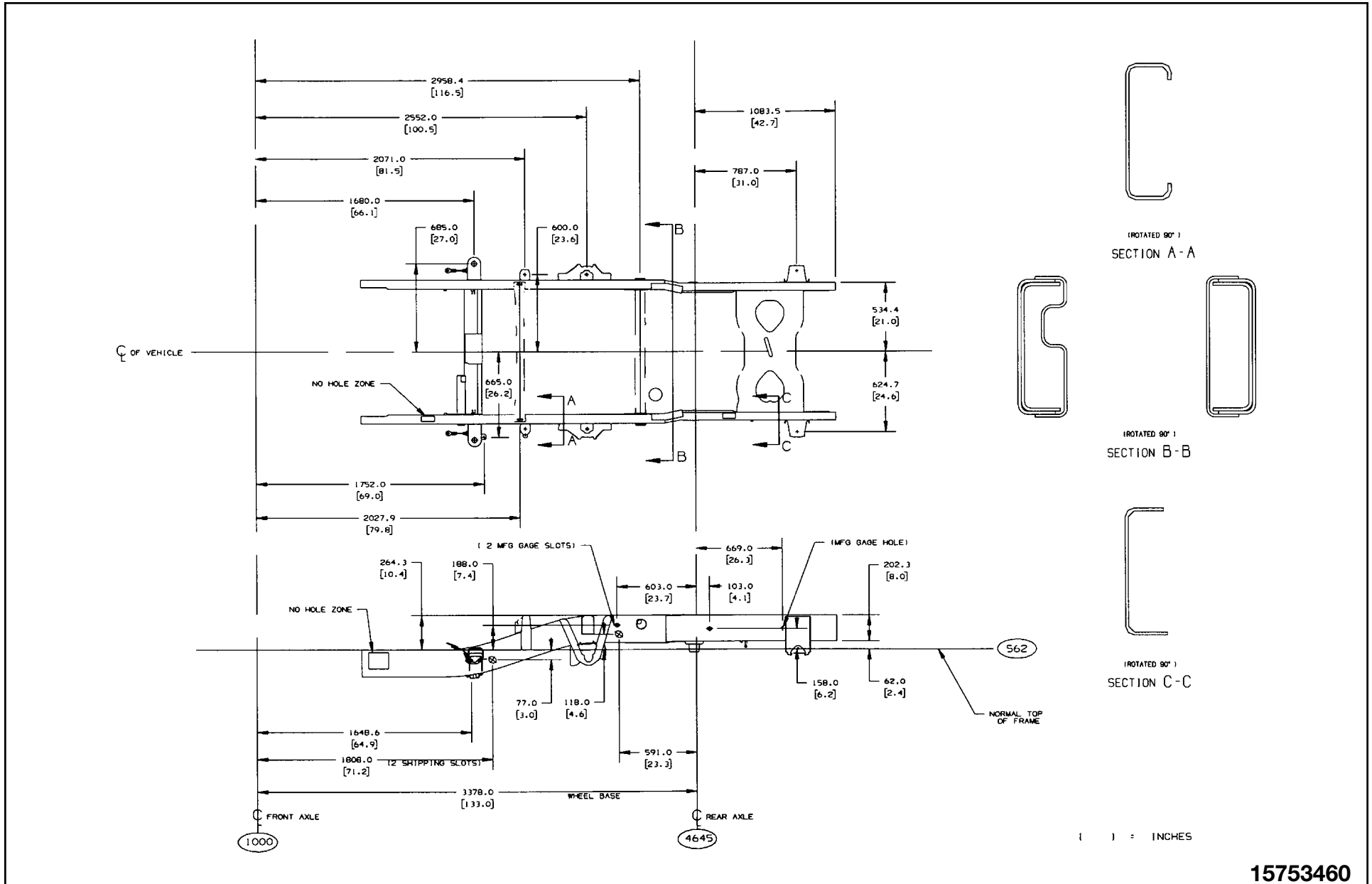

15753460

C/K 25753 HD Intermediate and Rear Frame

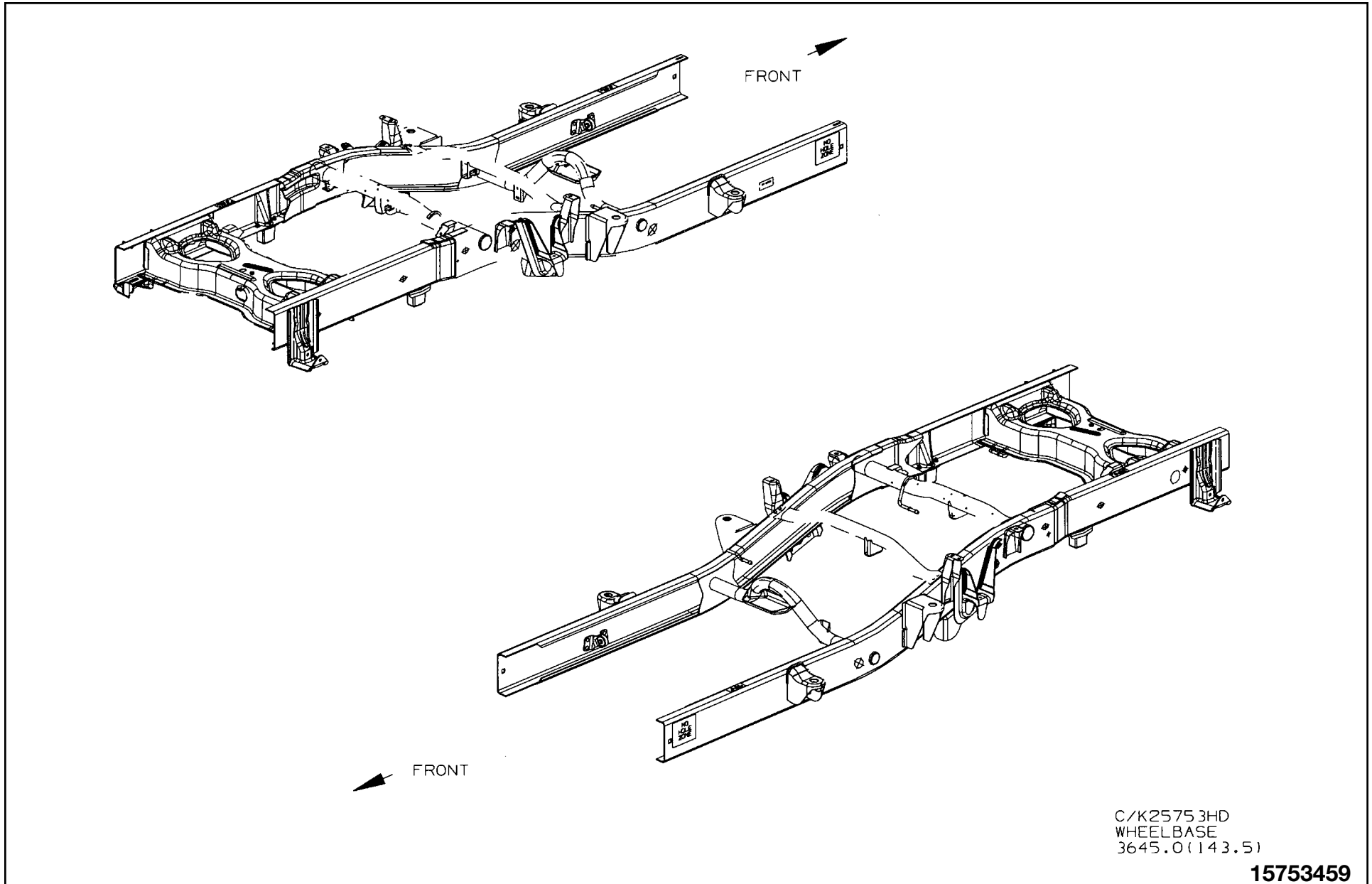

C/K 25753 HD Intermediate and Rear Frame W/Dim

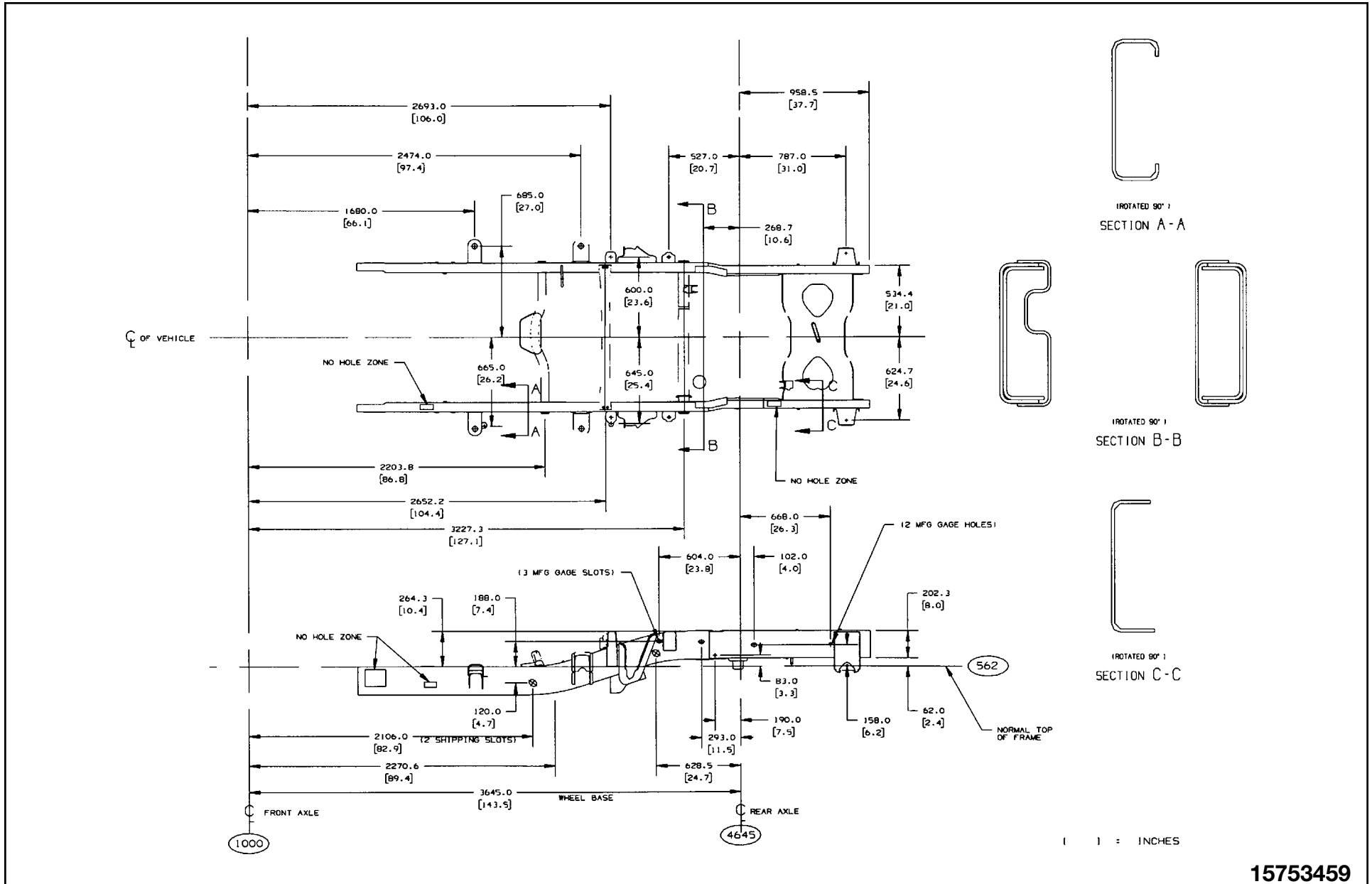

15753459

C/K (25HD/35)953 Intermediate and Rear Frame

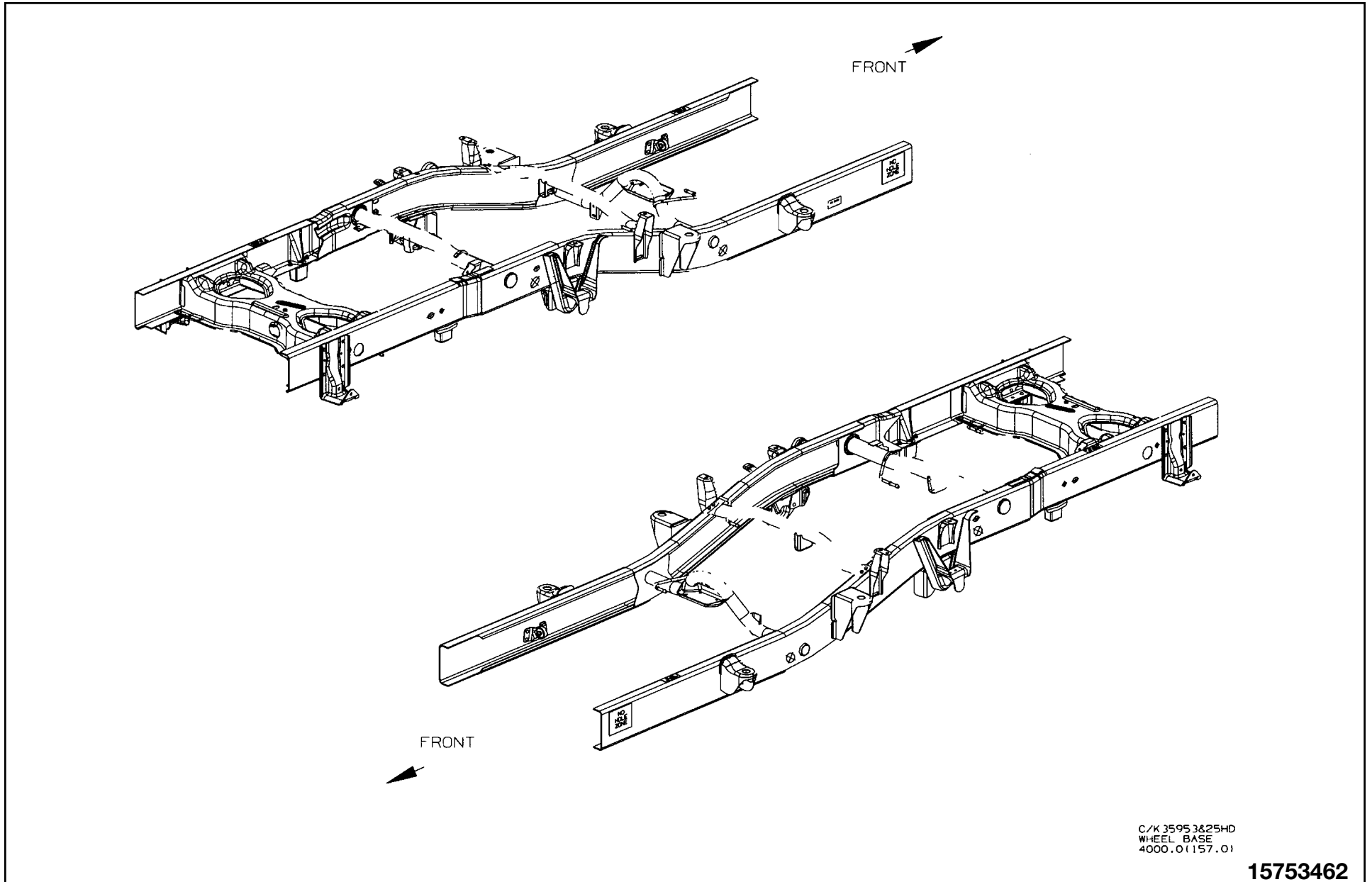

C/K (25HD/35)953 Intermediate and Rear Frame W/Dim

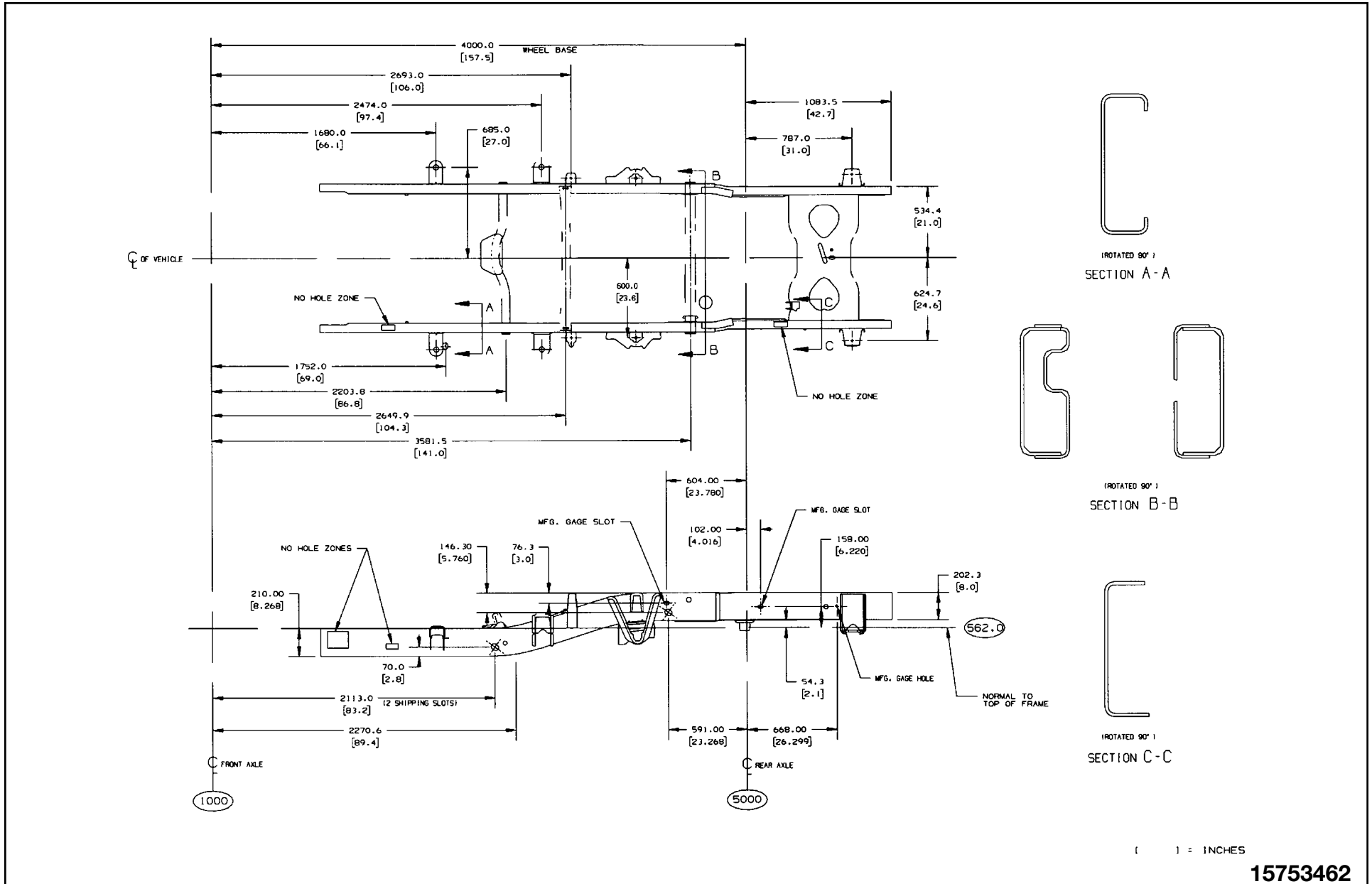

15753462

C/K 25743 HD Intermediate and Rear Frame

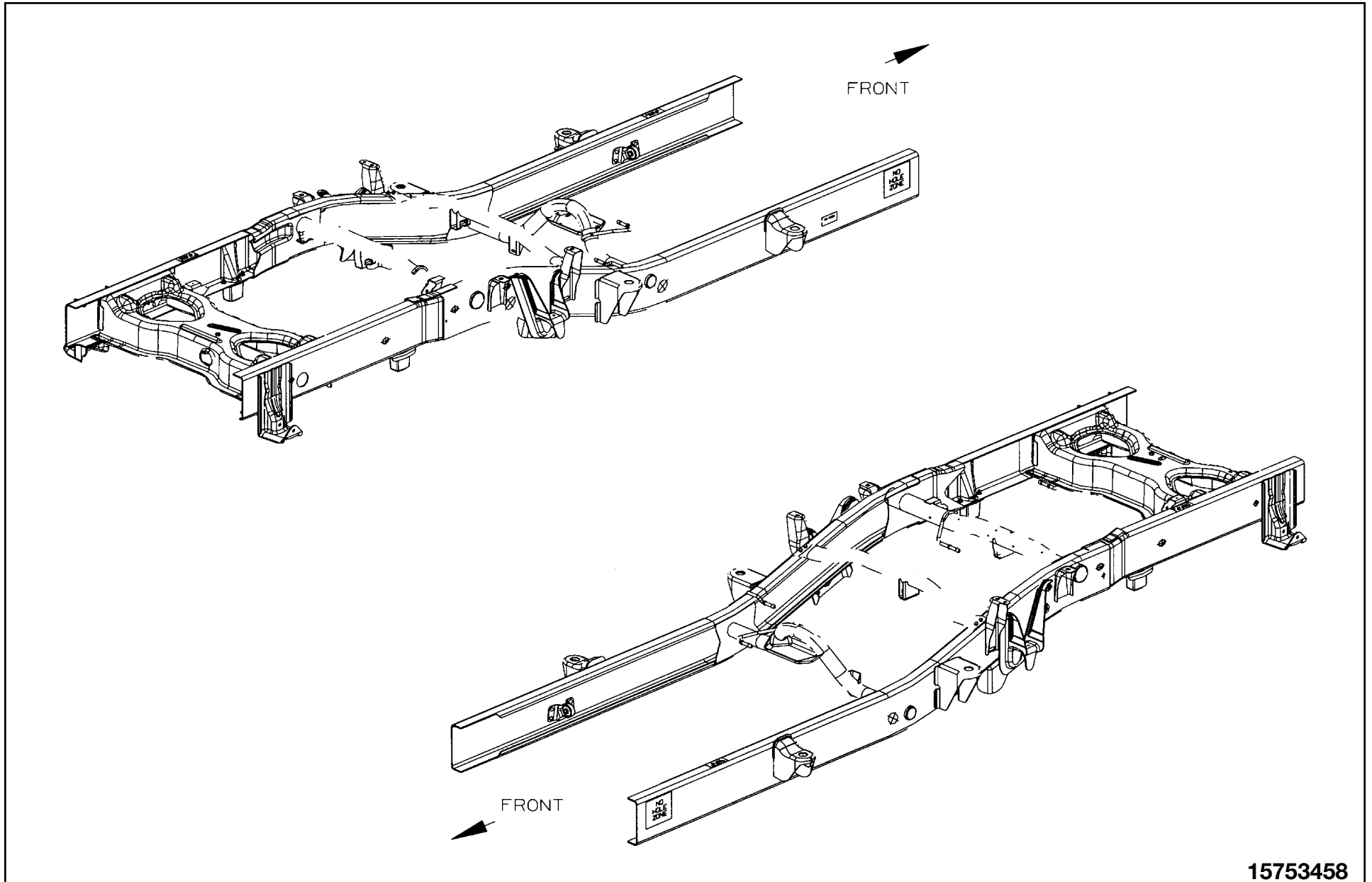

15753458

C/K 25743 HD Intermediate and Rear Frame W/Dim

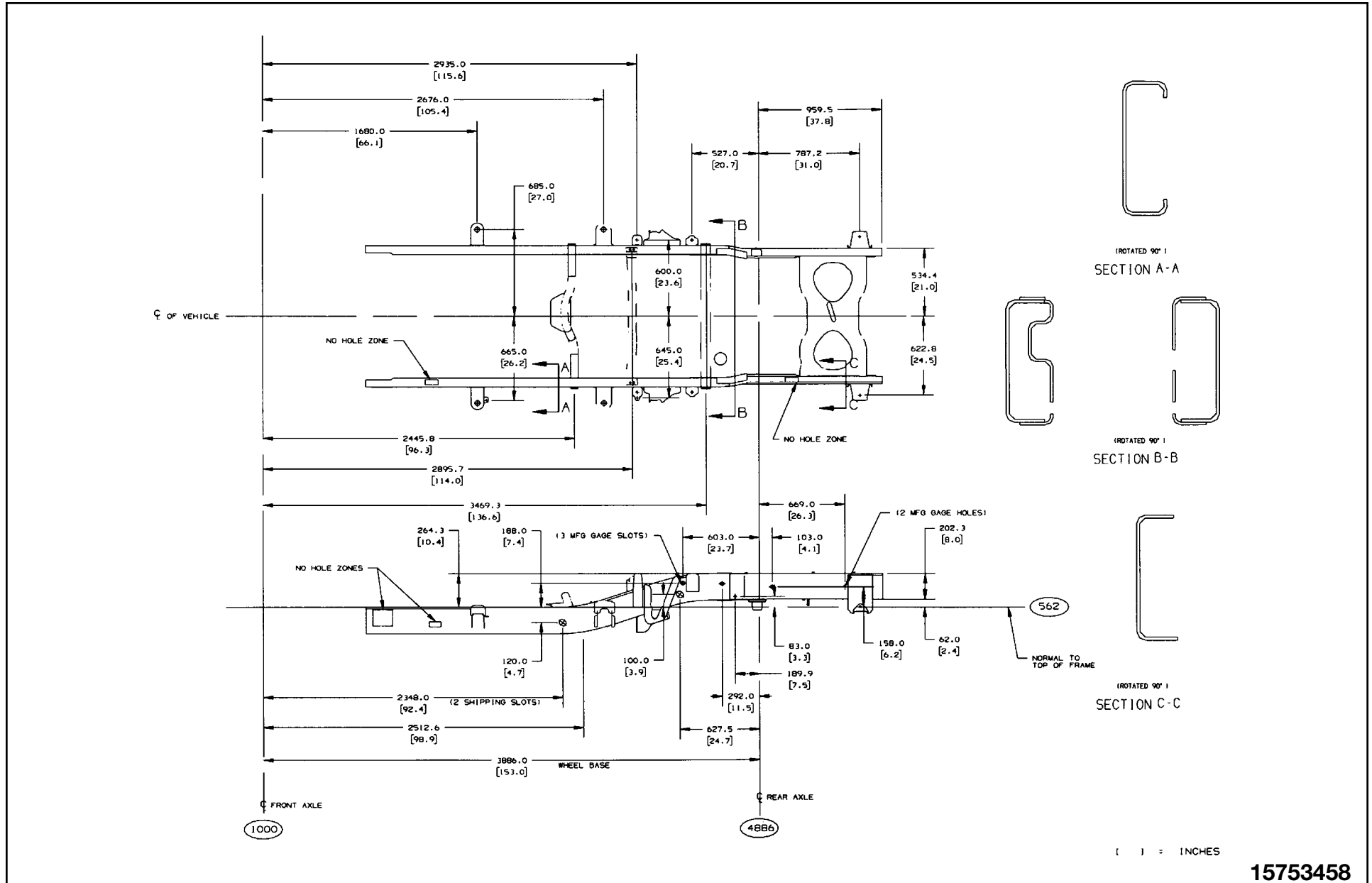

15753458

C/K (25HD/35)943 Intermediate and Rear Frame

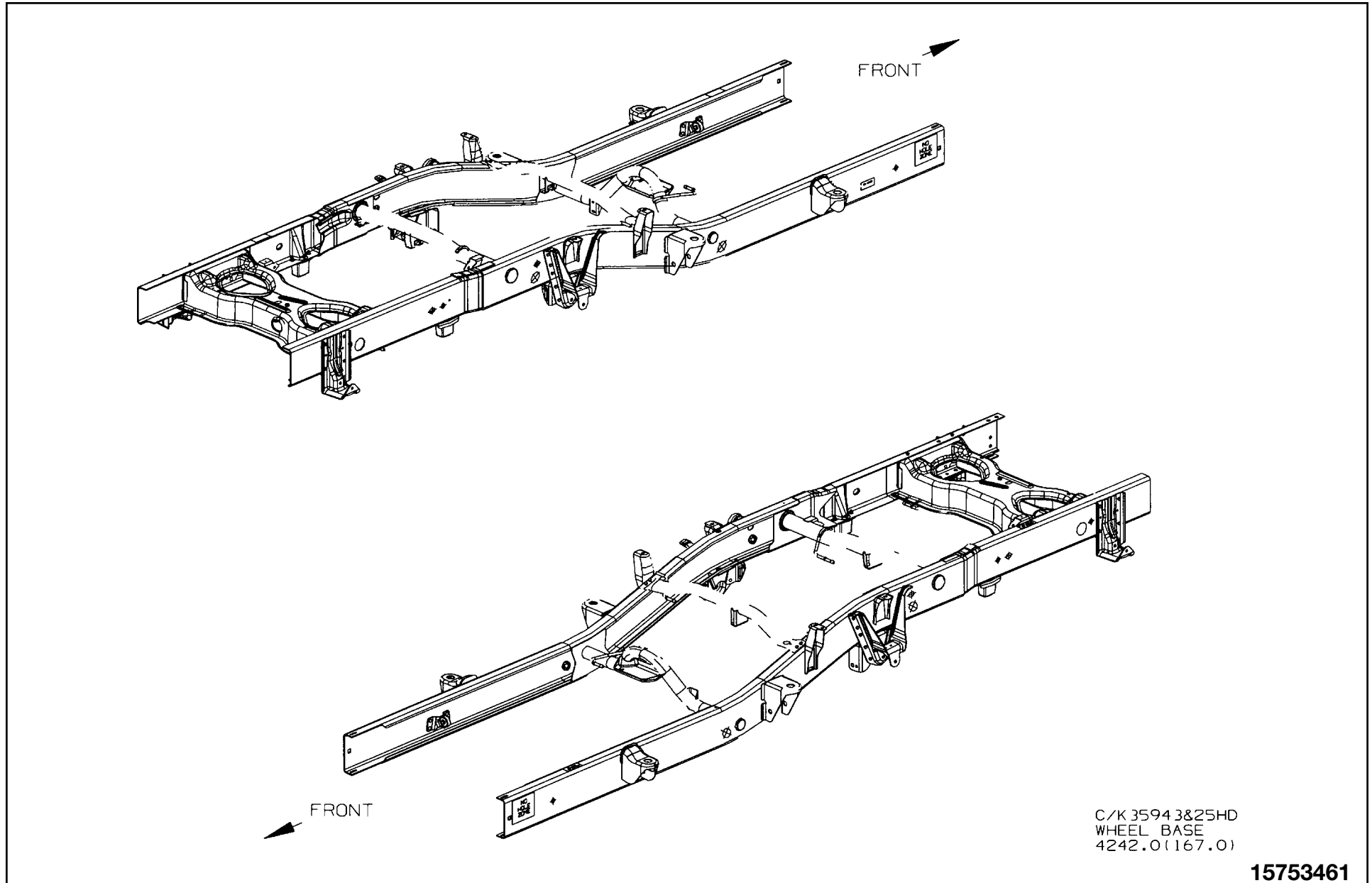

C/K (25HD/35)943 Intermediate and Rear Frame W/Dim

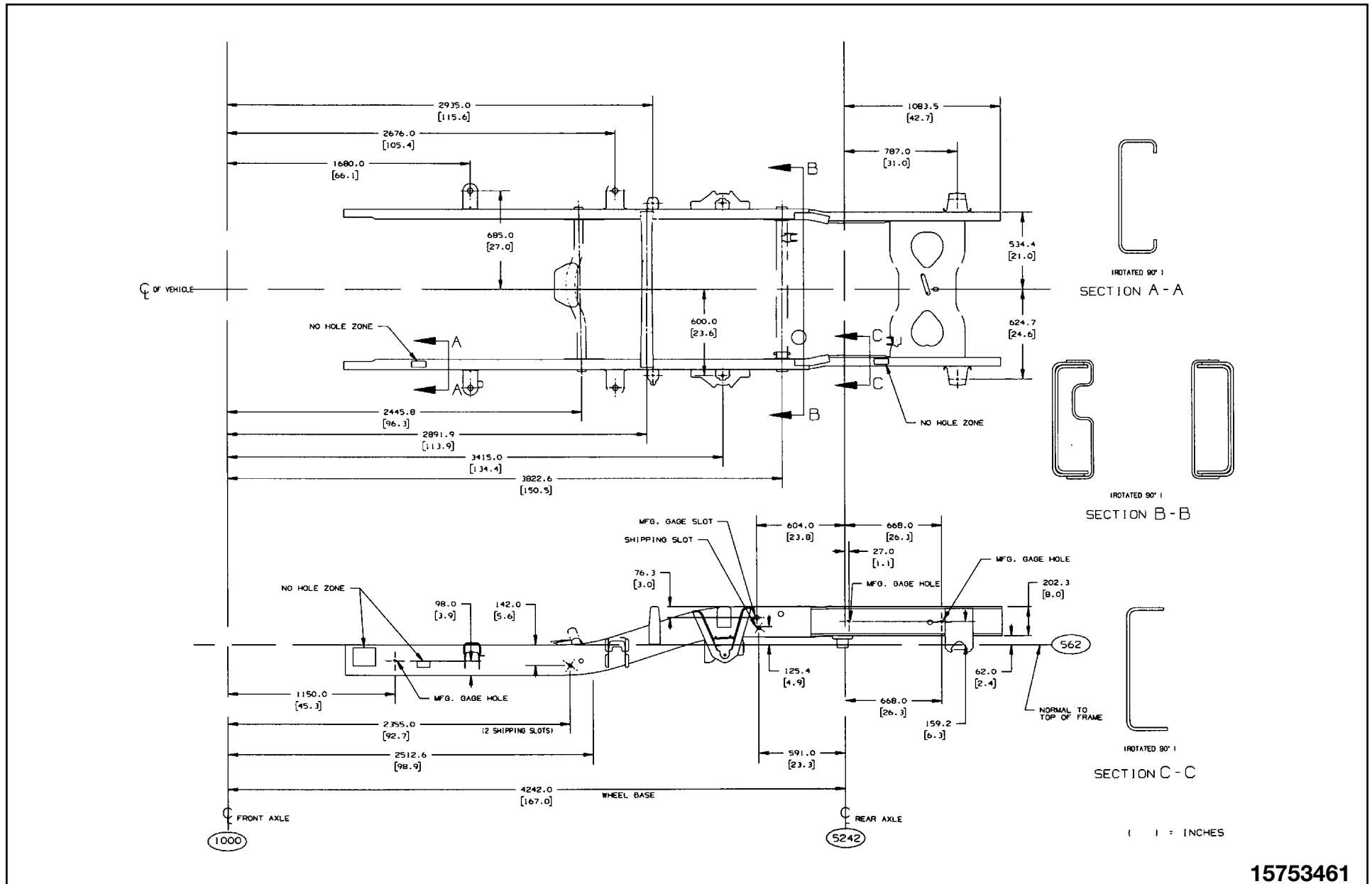

15753461

C/K 36003 Intermediate and Rear Frame

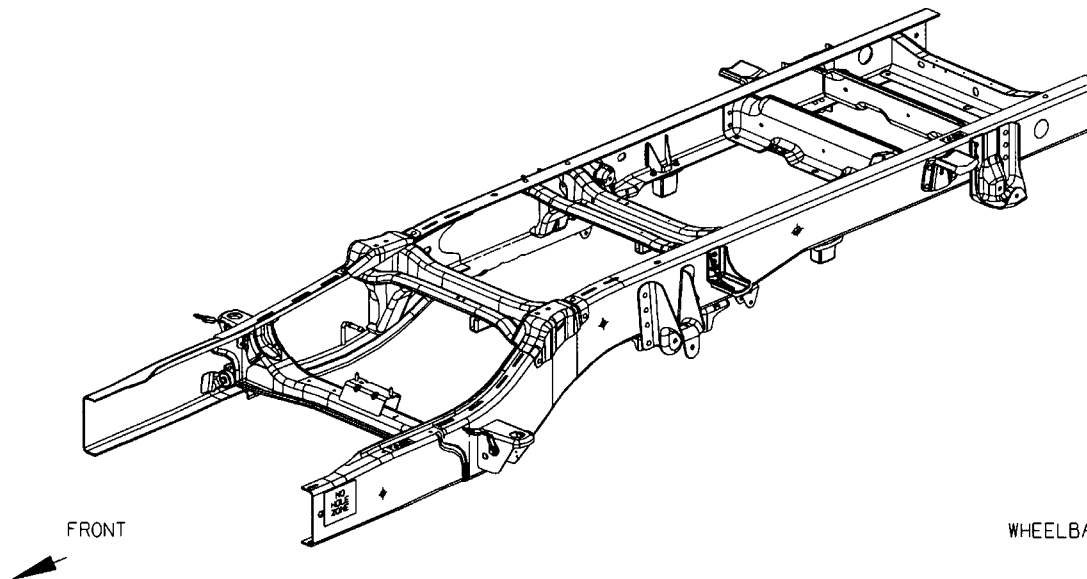
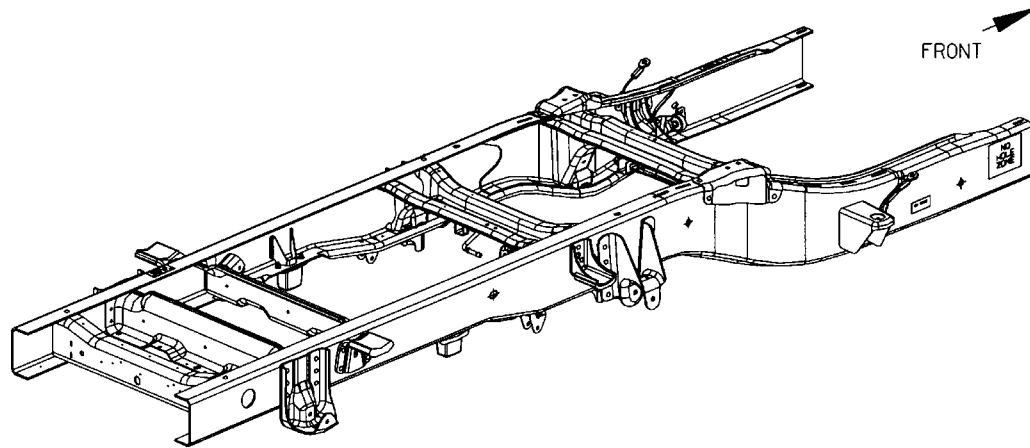

C/K 36003

WHEELBASE 3480.0 (1137.0)

15753471

C/K 36003 Intermediate and Rear Frame W/Dim

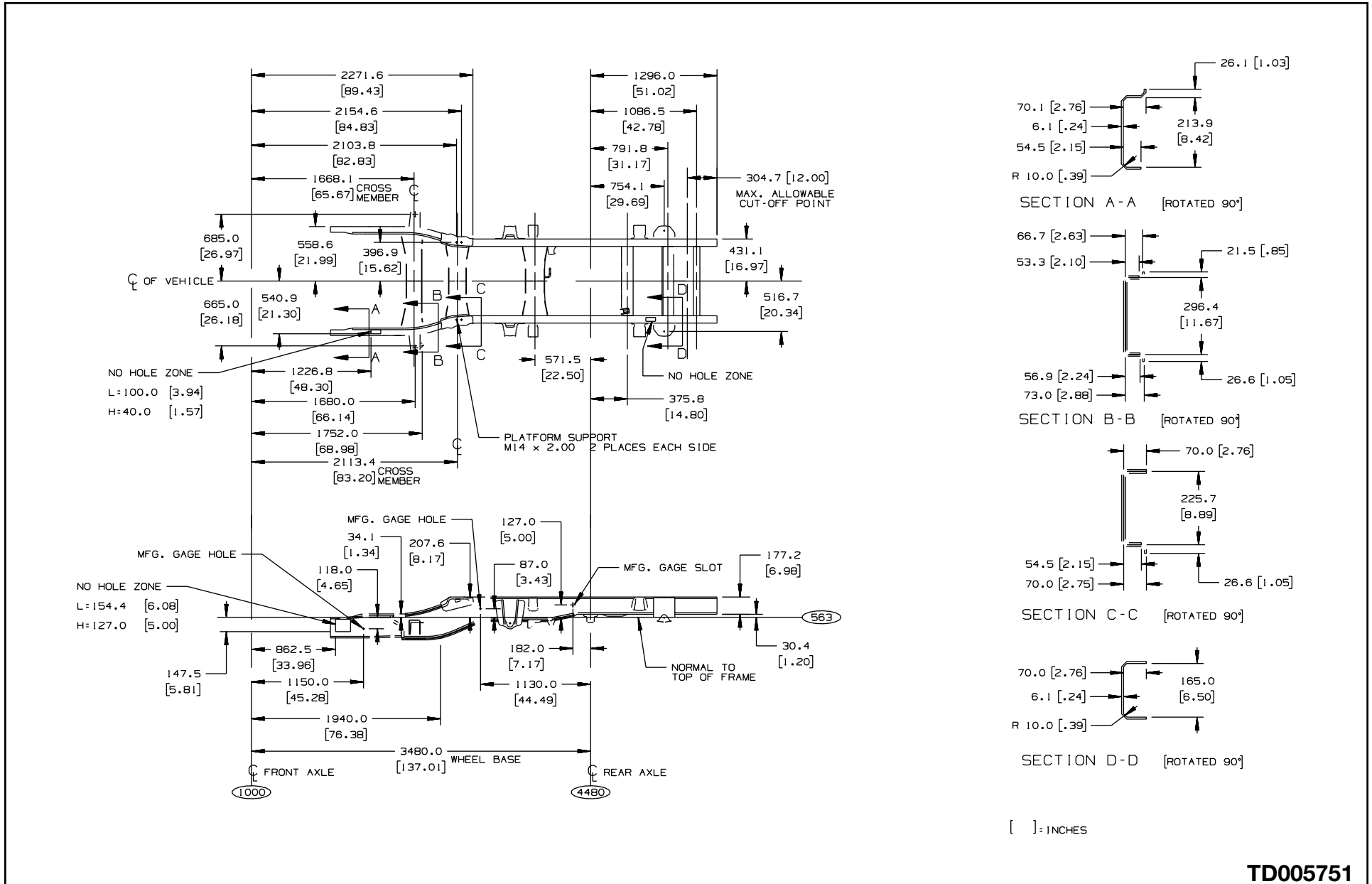

TD005751

C/K 36403 Intermediate and Rear Frame

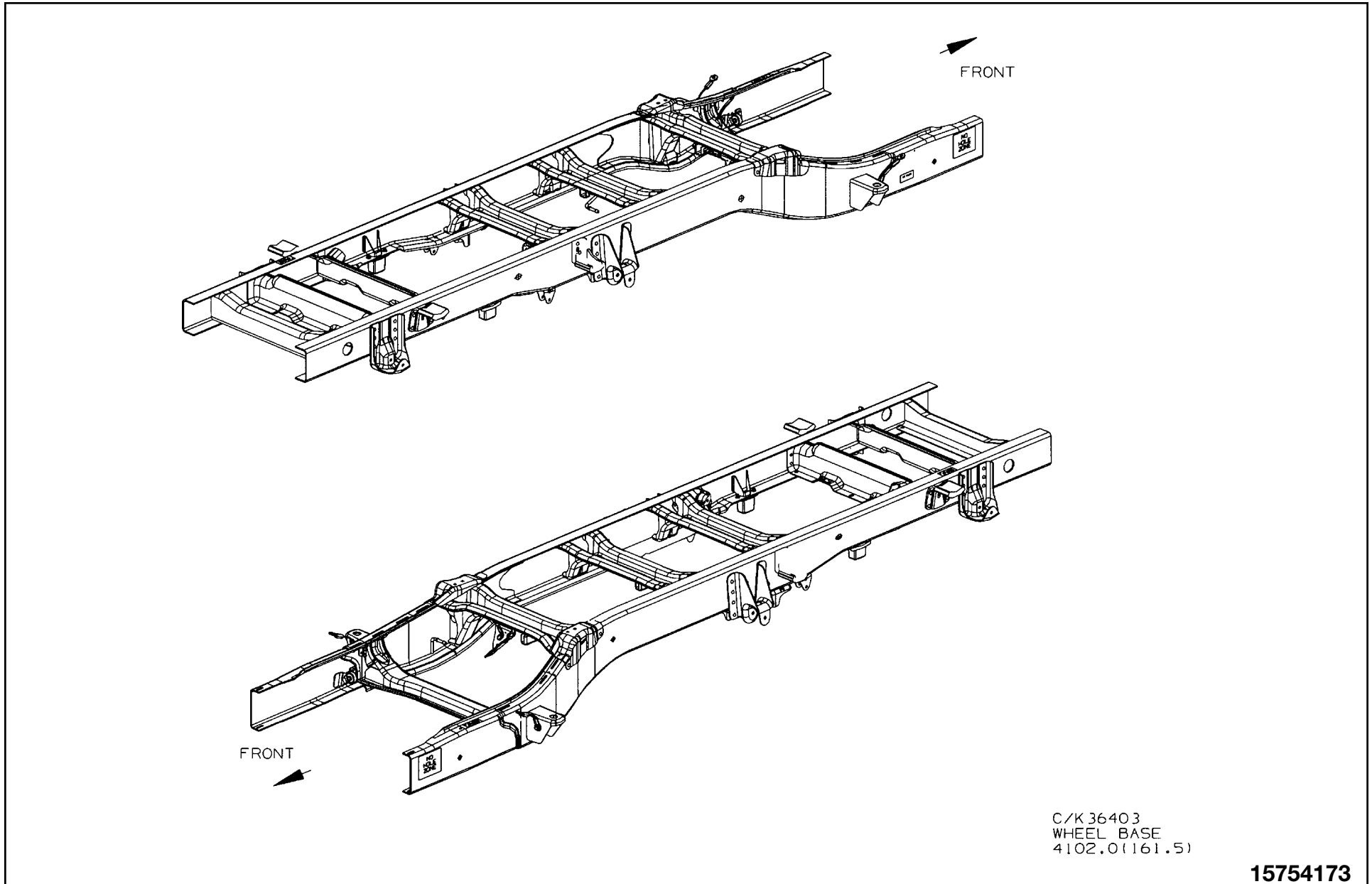

C/K 36403 Intermediate and Rear Frame W/Dim

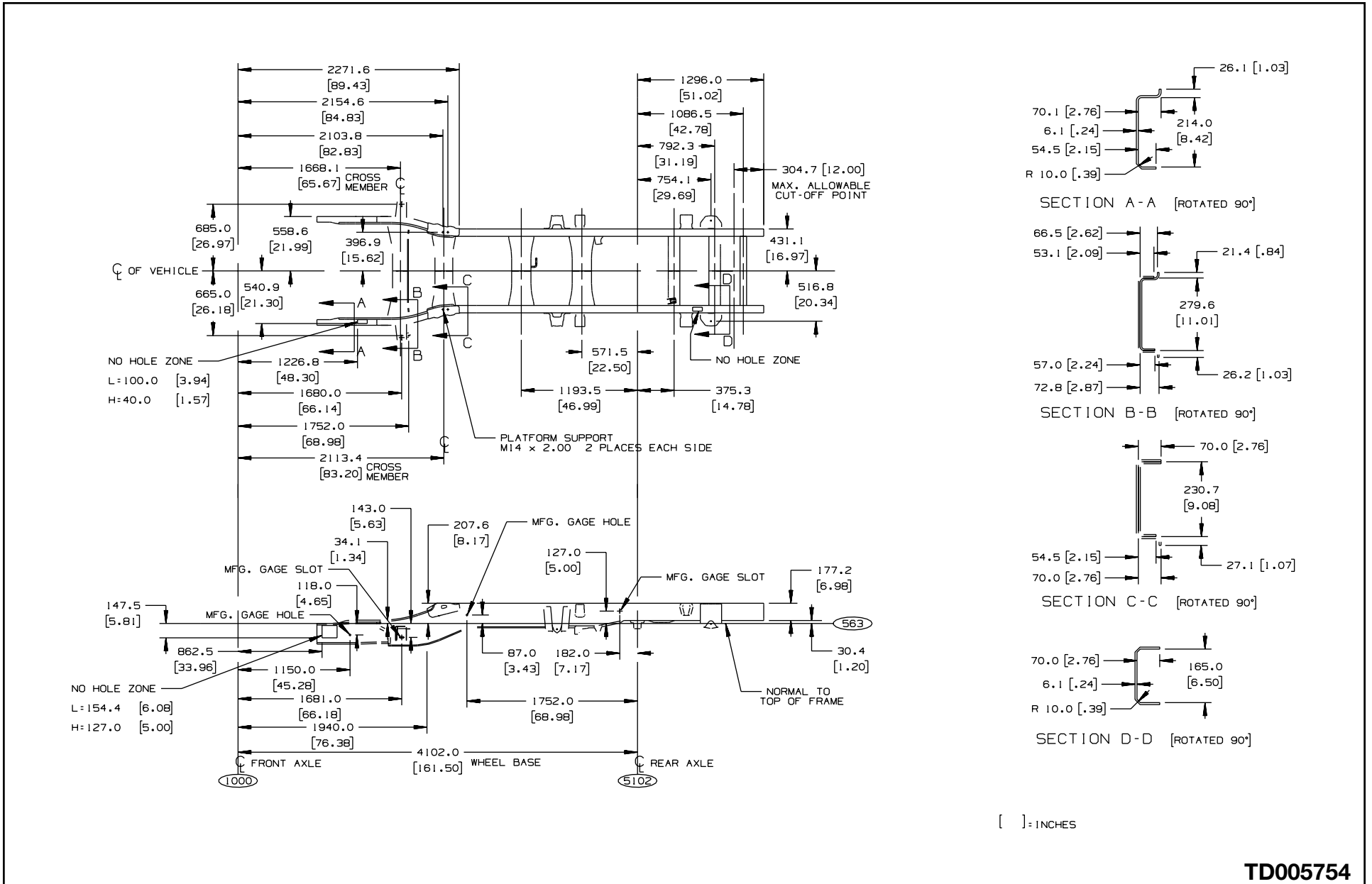

C/K 36053 Intermediate and Rear Frame

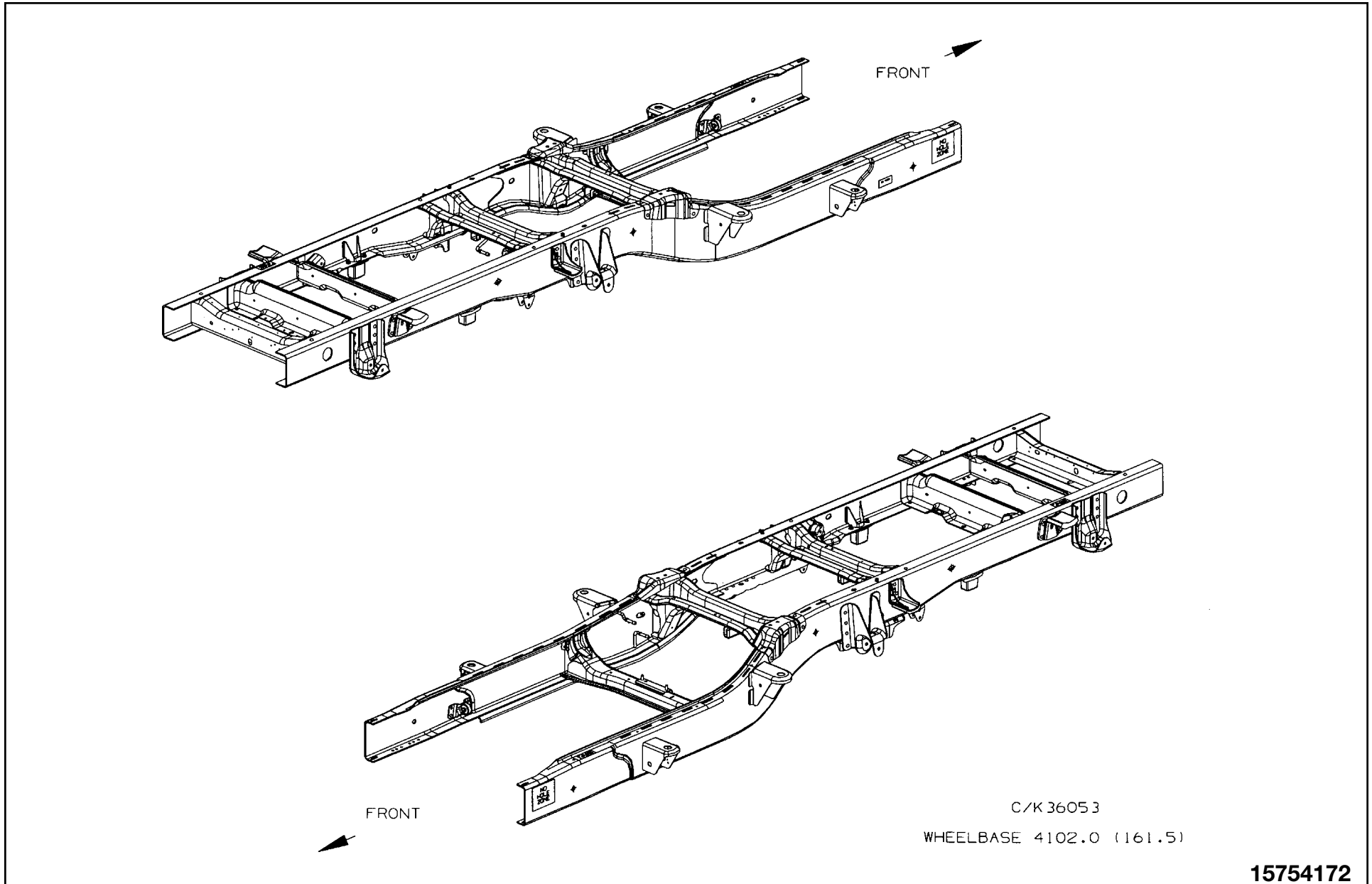

15754172

C/K 36053 Intermediate and Rear Frame W/Dim

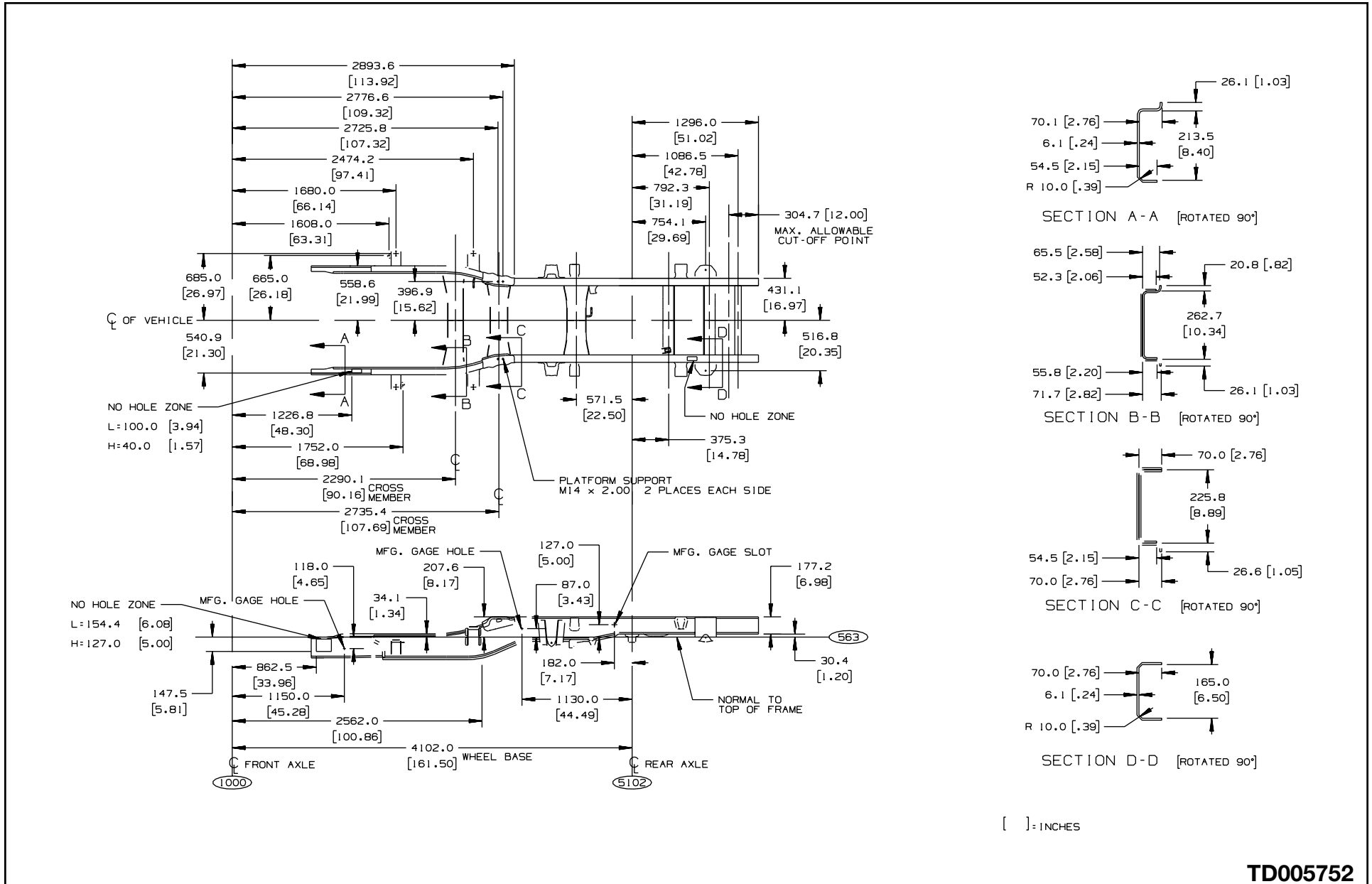

TD005752

C/K 36453 Intermediate and Rear Frame

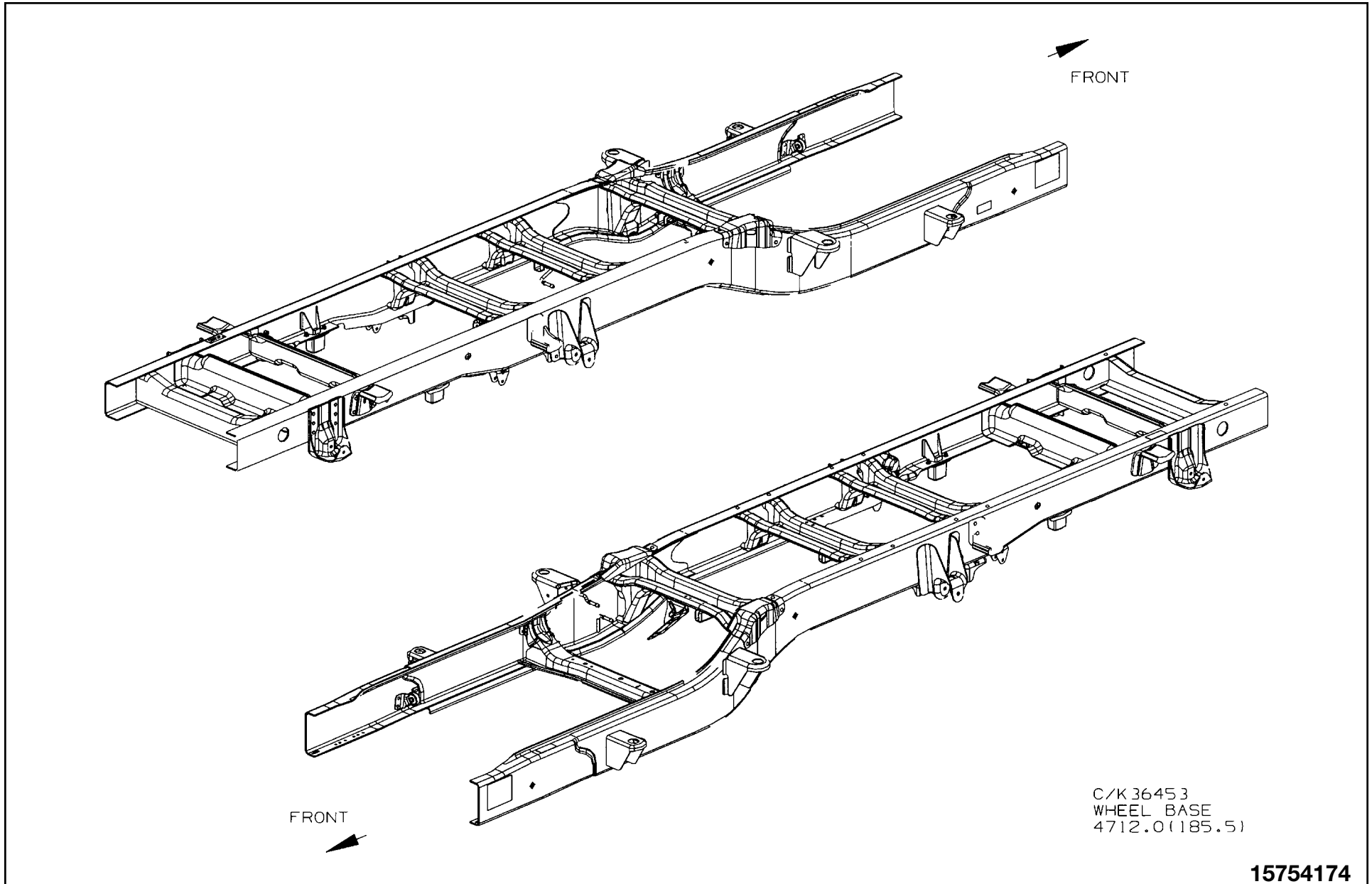

C/K 36453 Intermediate and Rear Frame W/Dim

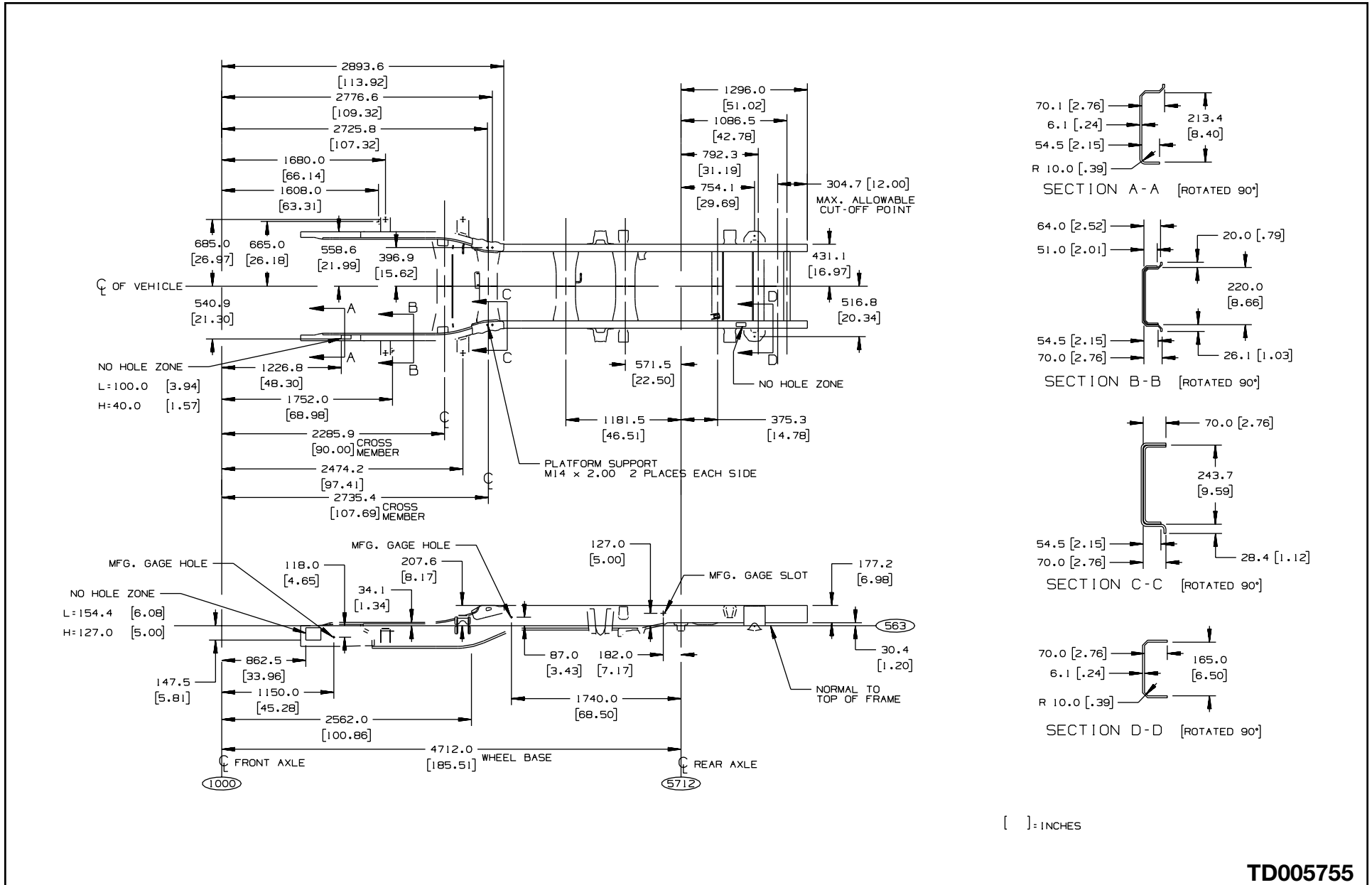

TD005755

C/K (15/25) Spare Tire Carrier Pickup

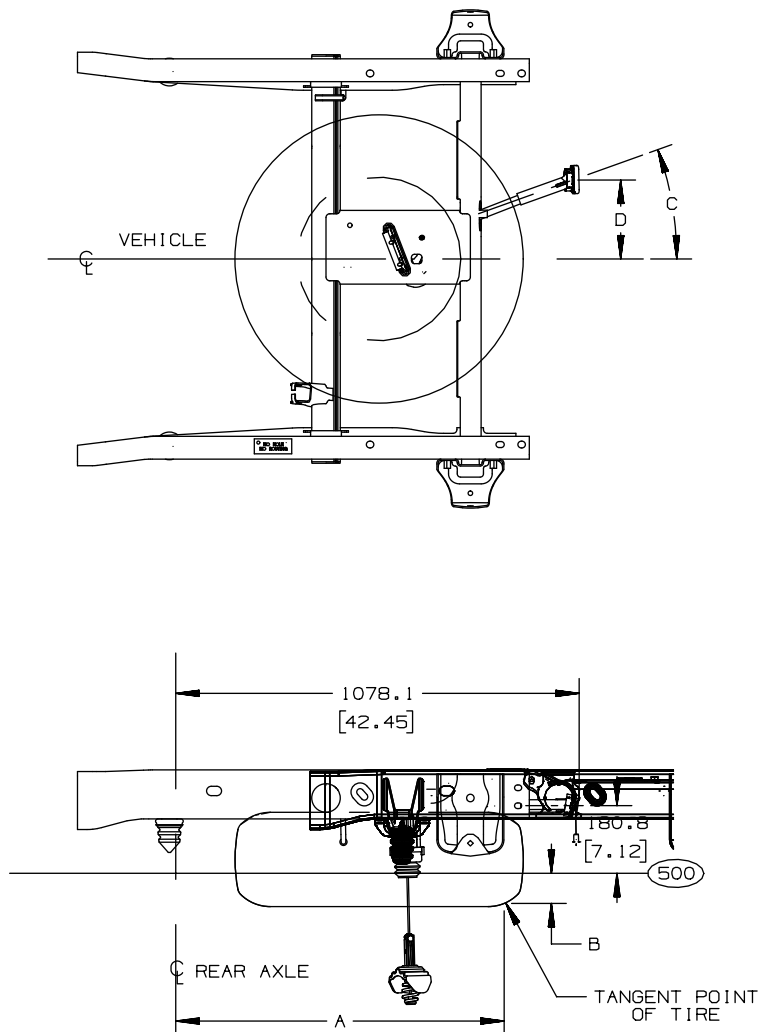

C/K (15/25) SPARE TIRE PICKUP 2003/04

MODEL	TIRE	A	B	C	D
C15703	P235/75R16	877.7 [34.56]	80.5 [3.17]	19.4°	210.9 [8.30]
	P255/70R16-109H	918.5 [36.16]	100.5 [3.96]	19.4°	210.9 [8.30]
C15753	P235/75R16	877.7 [34.56]	80.5 [3.17]	18.8°	213.2 [8.39]
	P255/70R16-109H	918.5 [36.16]	100.5 [3.96]	18.8°	213.2 [8.39]
C/K15743	LT245/75R16	923.7 [36.37]	89.2 [3.51]	18.8°	213.2 [8.39]
C25743	LT245/75R16	923.7 [36.37]	89.2 [3.51]	18.8°	213.2 [8.39]
C25753	LT225/75R16	895.2 [35.24]	58.6 [2.31]	18.8°	213.2 [8.39]
	LT245/75R16	923.7 [36.37]	89.2 [3.51]	18.8°	213.2 [8.39]
K25753	LT245/75R16	923.7 [36.37]	89.2 [3.51]	18.8°	213.2 [8.39]
C15903	P235/75R16	877.7 [34.56]	80.5 [3.17]	19.1°	213.0 [8.39]
	P255/70R16-109H	918.5 [36.16]	100.5 [3.96]	19.1°	213.0 [8.39]
K15903	P245/75R16-109S	921.8 [36.29]	83.1 [3.27]	19.1°	213.0 [8.39]
	P265/75R16-114H	933.9 [36.77]	108.5 [4.27]	19.1°	213.0 [8.39]
	LT245/75R16	923.7 [36.37]	89.2 [3.51]	19.1°	213.0 [8.39]
C15953	P235/75R16	877.7 [34.56]	80.5 [3.17]	17.3°	212.4 [8.36]
	P255/70R16-109H	918.5 [36.16]	100.5 [3.96]	17.3°	212.4 [8.36]
K15953	P245/75R16-109S	921.8 [36.29]	83.1 [3.27]	17.3°	212.4 [8.36]
	P265/75R16-114H	934.8 [36.80]	97.5 [3.84]	17.3°	212.4 [8.36]
	LT245/75R16	923.7 [36.37]	89.2 [3.51]	17.3°	212.4 [8.36]
C15543	P255/70R16	918.5 [36.16]	100.5 [3.96]	17.3°	212.4 [8.36]
K15543	P265/70R17	894.0 [35.20]	80.5 [3.17]	19.4°	210.9 [8.30]

[] = INCHES

C/K (15/25) Spare Tire Carrier Utility

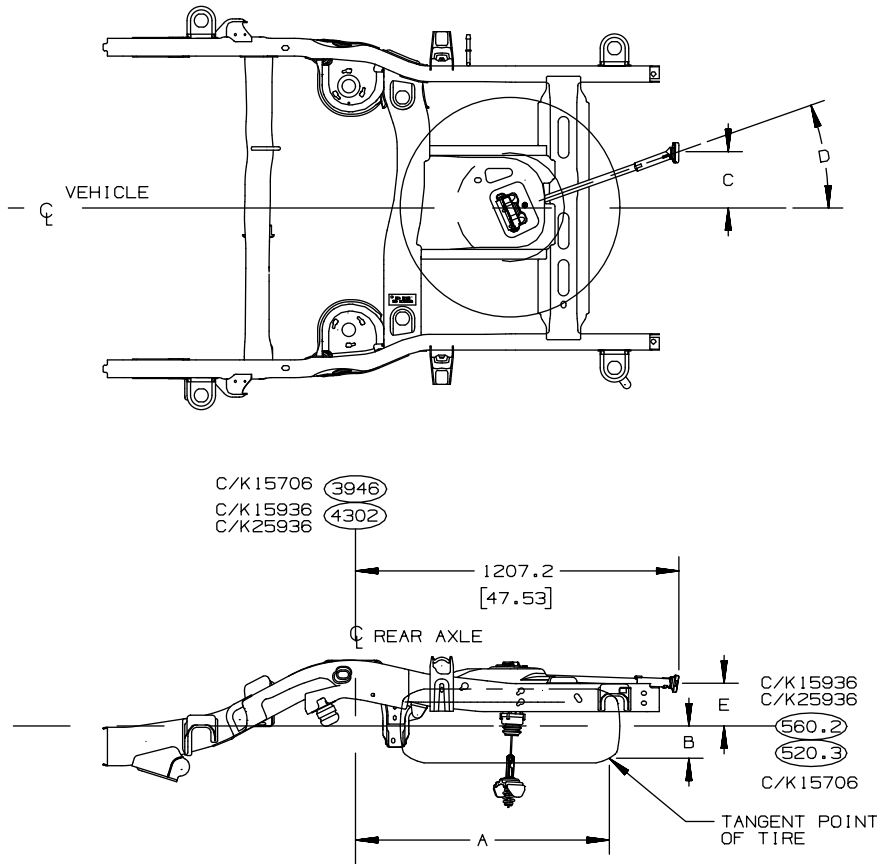

MODEL	TIRE	A	B	C	D	E
C/K25906	LT245/75R16/E	930.7 [36.64]	209.3 [8.24]	209.9 [8.26]	17.1°	119.5 [4.70]
	LT245/75R16/E,C	930.7 [36.64]	209.3 [8.24]	209.9 [8.26]	17.1°	119.5 [4.70]
C15706	P265/70R16 - 111S	923.6 [36.36]	108.2 [4.26]	209.9 [8.26]	27.9°	159.7 [6.29]
	P245/75R16 - 109S	921.8 [36.29]	94.1 [3.70]	209.9 [8.26]	27.9°	159.7 [6.29]
	P255/70R16 - 109H	918.5 [36.16]	100.5 [3.96]	209.9 [8.26]	27.9°	159.7 [6.29]
K15706	LT245/75R16/C	923.7 [36.37]	89.2 [3.51]	209.9 [8.26]	27.9°	159.7 [6.29]
	P265/75R16 - 114S	933.9 [36.77]	108.5 [4.27]	209.9 [8.26]	27.9°	159.7 [6.29]
	LT265/75R16 - C	940.0 [37.01]	106.4 [4.19]	209.9 [8.26]	27.9°	159.7 [6.29]
	P265/75R16 - 114H	933.9 [36.77]	108.5 [4.27]	209.9 [8.26]	27.9°	159.7 [6.29]
	P265/70R16 - 111S	923.6 [36.36]	108.2 [4.26]	209.9 [8.26]	27.9°	159.7 [6.29]
	P245/75R16 - 109S	921.8 [36.29]	94.1 [3.70]	209.9 [8.26]	21.7°	159.7 [6.29]
C15906	P265/70R16 - 111S	923.7 [36.37]	89.2 [3.51]	209.9 [8.26]	21.7°	159.7 [6.29]
	P245/75R16 - 109S	921.8 [36.29]	83.1 [3.27]	209.9 [8.26]	21.7°	159.7 [6.29]
	P255/70R16 - 109H	918.5 [36.16]	89.5 [3.52]	209.9 [8.26]	21.7°	159.7 [6.29]
K15906	P265/70R16 - 111S	923.7 [36.37]	97.2 [3.83]	209.9 [8.26]	21.7°	159.7 [6.29]
	P245/75R16 - 109S	921.8 [36.29]	83.1 [3.27]	209.9 [8.26]	21.7°	159.7 [6.29]
	P265/75R16 - 114H	934.0 [36.77]	97.5 [3.84]	209.9 [8.26]	21.7°	159.7 [6.29]
C/K15936	P265/70R16	923.6 [36.36]	108.2 [4.26]	209.9 [8.26]	27.9°	159.7 [6.29]
	P265/70R17	923.6 [36.36]	108.2 [4.26]	209.9 [8.26]	27.9°	159.7 [6.29]
C/K25936	LT245/75R16	930.7 [36.64]	209.3 [8.24]	209.9 [8.26]	17.1°	119.5 [4.70]

C/K (15/25) SPARE TIRE CARRIER UTILITY 2003

[] = INCHES

TD006070b

C/K (25HD/35) Spare Tire Carrier

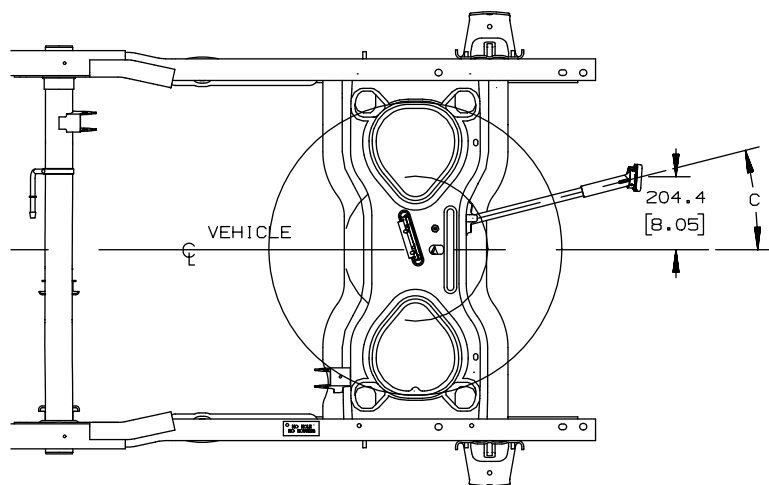

MODEL	TIRE	A	B	C
C/K25 HD ALL	LT245/75R16/E	923.1 [36.34]	176.0 [6.93]	19.3°
C35943	LT215/85R16/D	923.1 [36.34]	176.0 [6.93]	19.3°
C35953		923.1 [36.34]	176.0 [6.93]	19.3°
K35903	LT215/85R16/D	923.1 [36.34]	176.0 [6.93]	19.3°
K35943	LT215/85R16/E	923.1 [36.34]	176.0 [6.93]	19.3°
K35953		923.1 [36.34]	176.0 [6.93]	19.3°

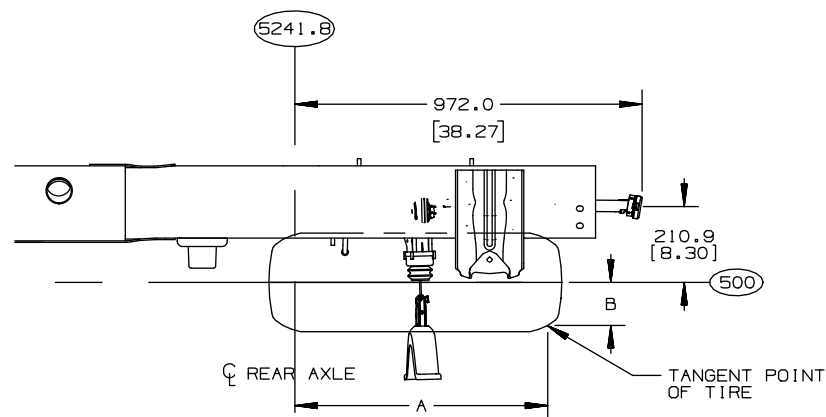

C/K (25HD/35) SPARE TIRE CARRIER 2003

[] = INCHES

C/K (15/25) Platform Hitch Pickup

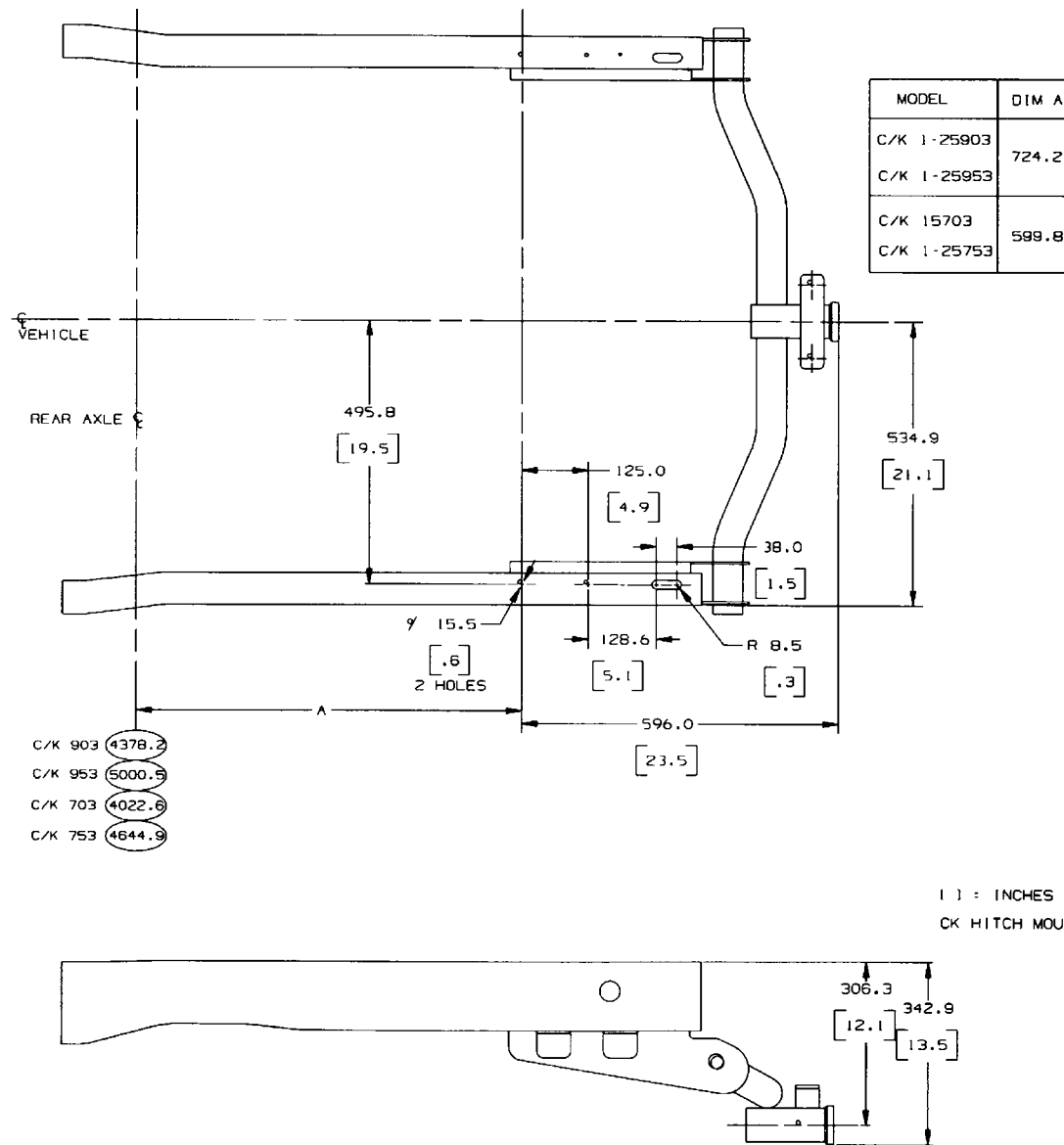

TD005328

C/K (15/25) Platform Hitch Utility

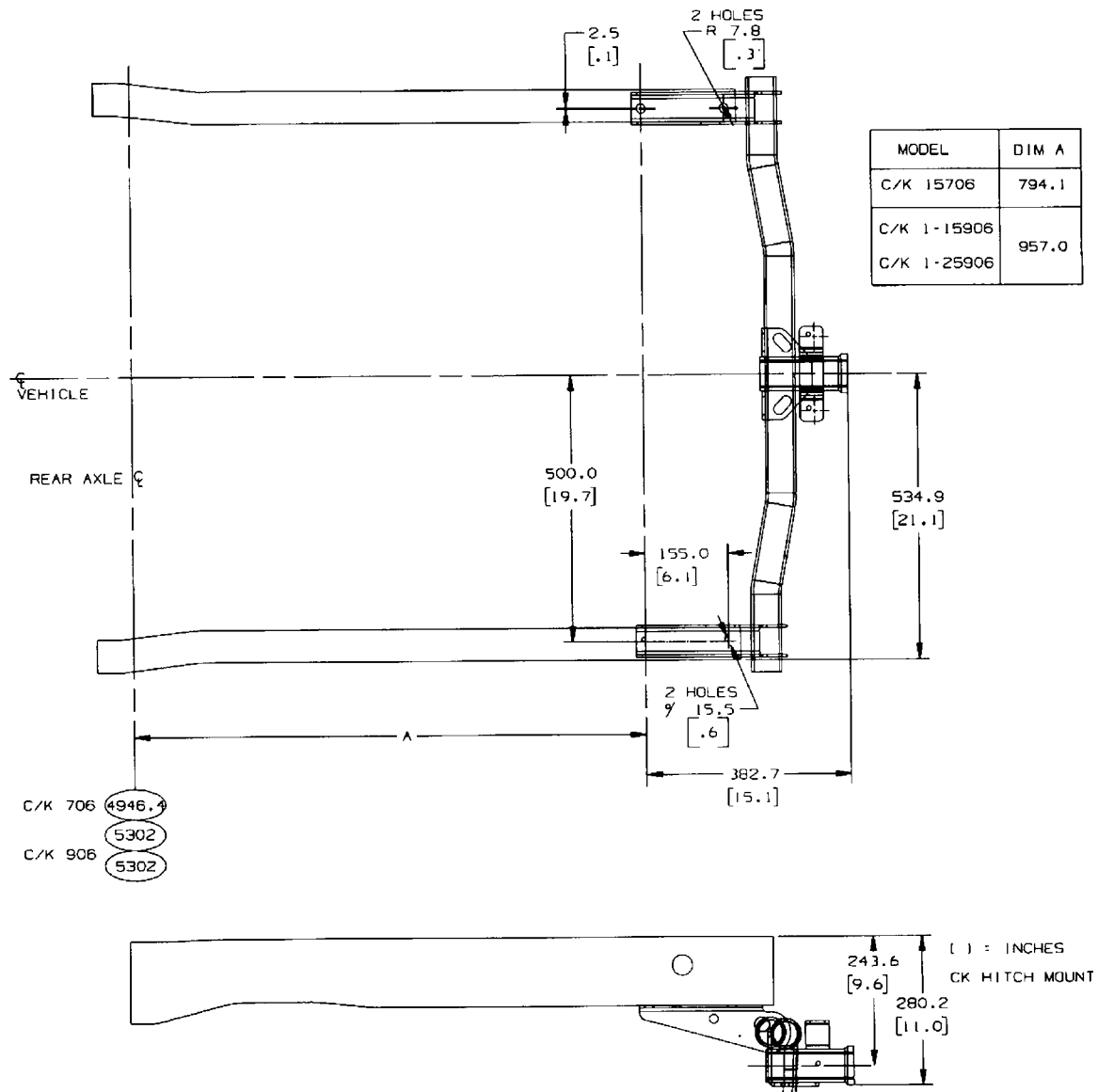

TD005360a

C/K (25HD) Platform Hitch Short Box Pickup

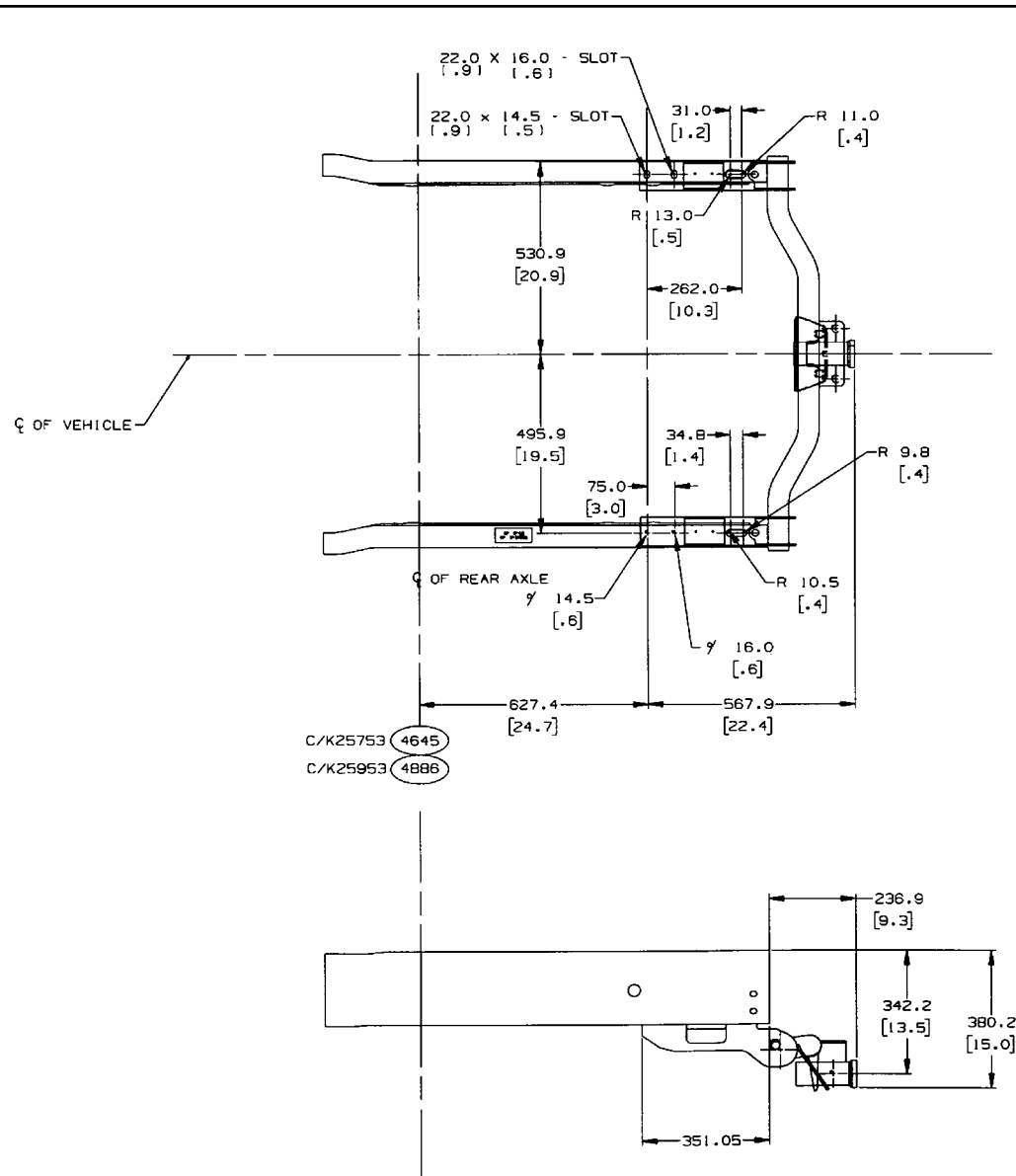

[] : INCHES
C/K HITCH MOUNT

TD005360b

C/K (25HD/35) Platform Hitch Long Box Pickup

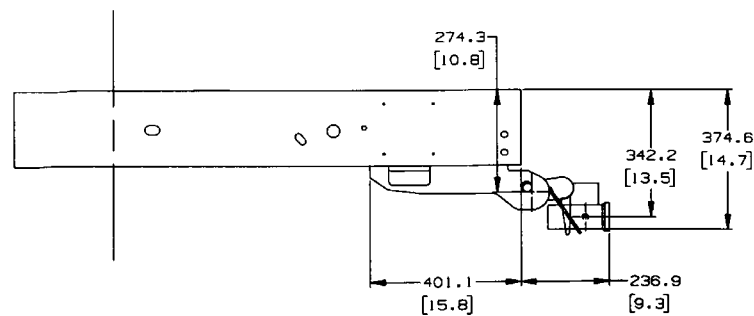
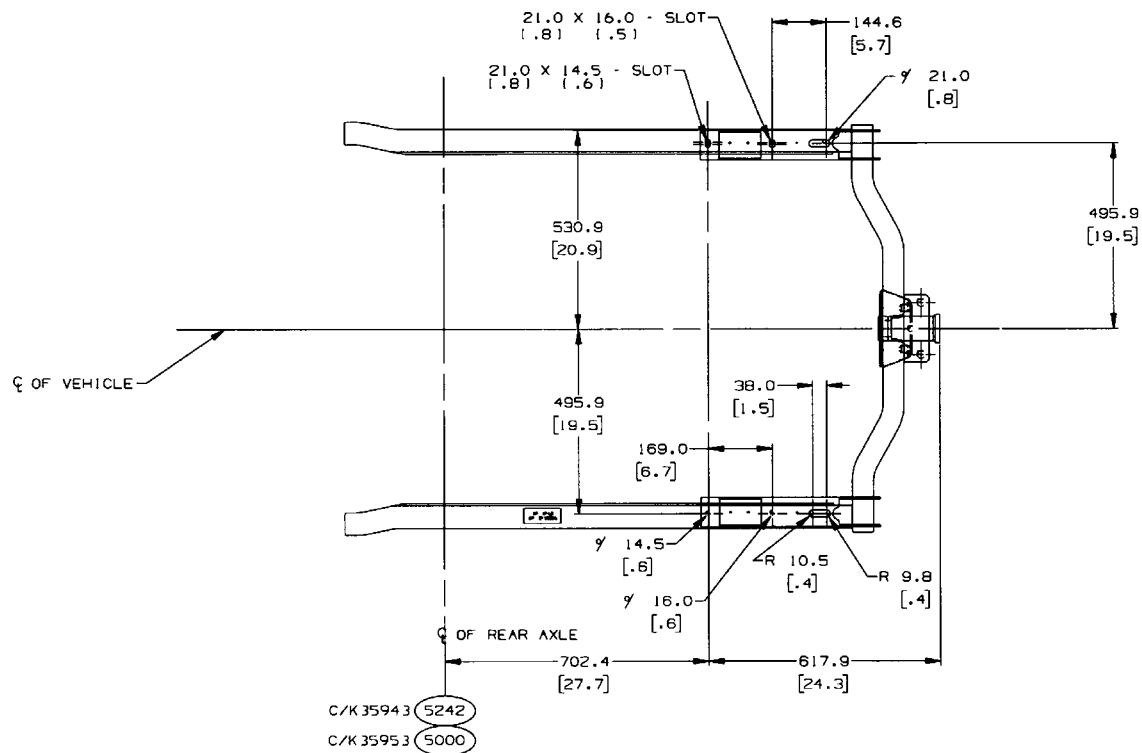

[] = INCHES
C/K HITCH MOUNT

TD005360c

C/K (15/25)936 Platform Hitch

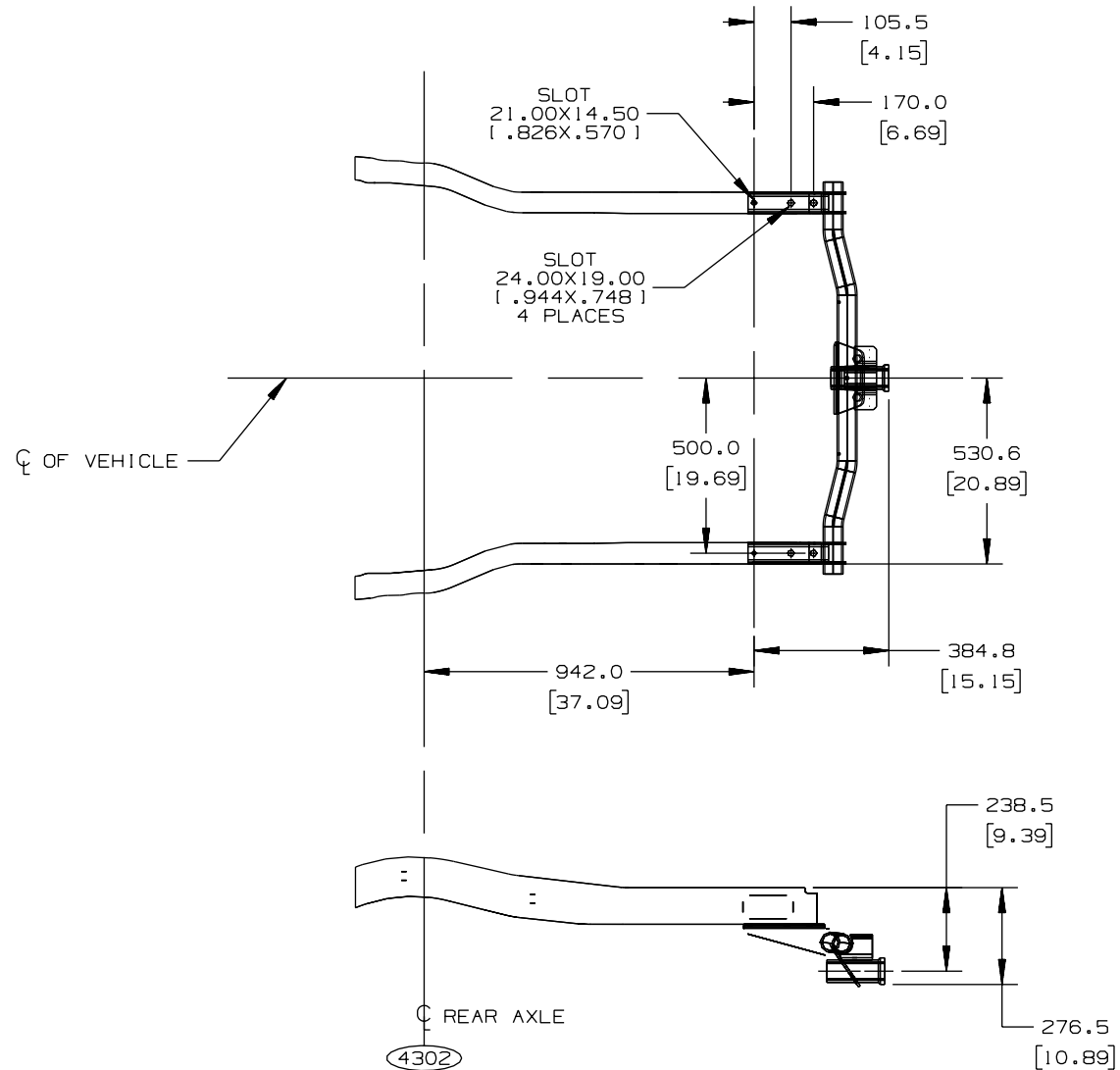

[] = INCHES

TD005795

C/K (15) Front Axle/Tire Data

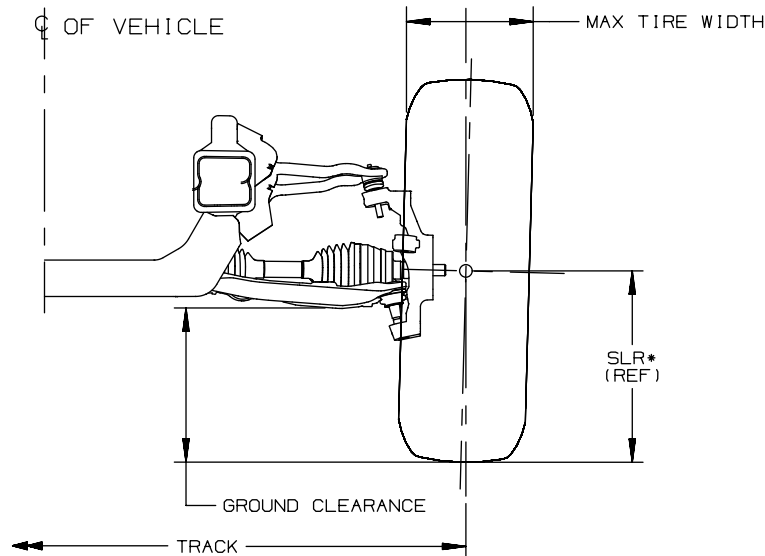

*MINIMUM GROUND CLEARANCE TO BE CALCULATED BY USING GROSS AXLE WEIGHT AND RECOMMENDED TIRE PRESSURE

SERIES	OPT	SLR	TIRES	GVW RATING	REAR WHEEL	TRACK	WHEEL OFFSET	MAX TIRE WIDTH	GROUND CLEARANCE
C15543		352	P255/70R16	6800	SINGLE	1651.0	31.0	268.0	239.8
K15543		373	P265/70R17	7000	SINGLE	1651.0	31.0	281.0	266.7
C15703		349	P235/75R16	6100	SINGLE	1651.0	31.0	252.0	243.8
		TBD	TBD	6700	SINGLE	1651.0	TBD	TBD	TBD
K15703		361	P245/75R16	6400	SINGLE	1651.0	31.0	261.0	254.7
		367	LT245/75R16	6400	SINGLE	1651.0	28.0	256.0	260.7
		377	P265/75R16	6400	SINGLE	1651.0	31.0	276.0	270.7
C15706		361	P245/75R16	6500	SINGLE	1651.0	31.0	261.0	254.7
		363	P265/70R16	6500	SINGLE	1651.0	31.0	276.0	256.7
		361	P245/75R16	6800	SINGLE	1651.0	31.0	261.0	254.7
		362	P265/70R16	6800	SINGLE	1651.0	31.0	276.0	255.7
		&Z75	374	P265/70R17	6800	SINGLE	1651.0	31.0	281.0

GMT800,C/K(15/25/35/36),2004,FRONT AXLE/TIRE DATA

TD006109a

2005 & BEYOND C/K FULL SIZE TRUCKS (PICKUPS, UTILITIES AND CHASSIS-CABS)

C/K (15) Front Axle/Tire Data

SERIES	OPT	SLR	TIRES	GVW RATING	REAR WHEEL	TRACK	WHEEL OFFSET	MAX TIRE WIDTH	GROUND CLEARANCE
K15706	FGAWR 3350	371	P265/70R17	6800	SINGLE	1651.0	31.0	281.0	264.7
		376	P265/75R16	6800	SINGLE	1651.0	31.0	276.0	269.7
		365	LT245/75R16	6800	SINGLE	1651.0	28.0	256.0	258.7
	FGAWR 3600	360	P245/75R16	6800	SINGLE	1651.0	31.0	261.0	253.7
		376	P265/75R16	6800	SINGLE	1651.0	31.0	276.0	269.7
		361	P265/70R16	6800	SINGLE	1651.0	31.0	276.0	254.7
		365	LT245/75R16	6800	SINGLE	1651.0	31.0	256.0	258.7
		359	P245/75R16	6900	SINGLE	1651.0	31.0	261.0	252.7
		361	P265/70R16	6900	SINGLE	1651.0	31.0	276.0	254.7
C15743		372	P265/70R17	7000	SINGLE	1651.0	31.0	281.0	265.7
		365	LT245/75R16	8600	SINGLE	1676.4	28.0	256.0	238.3
	&NYS	365	LT245/75R16	8600	SINGLE	1676.4	28.0	256.0	238.3
K15743		363	LT245/75R16	8600	SINGLE	1676.4	28.0	256.0	236.3
	&NYS	363	LT245/75R16	8600	SINGLE	1651.0	28.0	256.0	236.3
C15753		351	P235/75R16	6200	SINGLE	1651.0	28.0	252.0	242.8
		351	P255/70R16	6200	SINGLE	1651.0	28.0	268.0	243.8
		364	LT245/75R16	6200	SINGLE	1651.0	28.0	256.0	256.8
	&NYS	350	P255/70R16	6600	SINGLE	1651.0	28.0	268.0	242.8
K15753		357	P245/75R16	6400	SINGLE	1651.0	31.0	261.0	250.7
		365	LT245/75R16	6400	SINGLE	1651.0	28.0	256.0	258.7
		374	P265/75R16	6400	SINGLE	1651.0	31.0	276.0	267.7
		381	P275/55R20	6400	SINGLE	1651.0	40.0	288.0	274.7
	&NYS	358	P245/75R16	6900	SINGLE	1651.0	31.0	261.0	251.7
	&NYS	365	LT245/75R16	6900	SINGLE	1651.0	31.0	256.0	258.7
	&NYS	374	P265/75R16	6900	SINGLE	1651.0	31.0	276.0	267.7
	&NYS	370	P265/70R17	7200	SINGLE	1651.0	31.0	281.0	263.7
C15903		352	P235/75R16	6400	SINGLE	1651.0	31.0	252.0	245.8
		355	P255/70R16	6400	SINGLE	1651.0	31.0	268.0	249.8
K15903		360	P245/75R16	6400	SINGLE	1651.0	31.0	261.0	253.7
		367	LT245/75R16	6400	SINGLE	1651.0	28.0	256.0	260.7
		376	P265/75R16	6400	SINGLE	1651.0	31.0	276.0	269.7
C15906		361	P245/75R16	7000	SINGLE	1651.0	31.0	261.0	254.7
		362	P265/70R16	7000	SINGLE	1651.0	31.0	276.0	255.7

2005 & BEYOND C/K FULL SIZE TRUCKS (PICKUPS, UTILITIES AND CHASSIS-CABS)

C/K (15/25) Front Axle/Tire Data

SERIES	OPT	SLR	TIRES	GVW RATING	REAR WHEEL	TRACK	WHEEL OFFSET	MAX TIRE WIDTH	GROUND CLEARANCE
K15906	FGAWR3600	359	P245/75R16	7200	SINGLE	1651.0	31.0	261.0	252.7
		360	P265/70R16	7200	SINGLE	1651.0	31.0	276.0	253.7
	FGAWR3550	370	P265/70R17	7200	SINGLE	1651.0	31.0	281.0	263.7
		FGAWR3450	370	P265/70R17	7200	SINGLE	1651.0	31.0	281.0
C15936	&ZQ1	359	P245/75R16	6800	SINGLE	1651.0	31.0	261.0	252.7
	&ZQ1	360	P265/70R16	6800	SINGLE	1651.0	31.0	276.0	253.7
	&ZW7	372	P265/70R17	6800	SINGLE	1651.0	31.0	281.0	265.7
K15936	&ZQ1	358	P265/70R16	7000	SINGLE	1651.0	31.0	276.0	251.7
	&Z71	368	P265/70R17	7000	SINGLE	1651.0	31.0	281.0	261.7
	&Z75	370	P265/70R17	7000	SINGLE	1651.0	31.0	281.0	263.7
C15953		349	P235/75R16	6400	SINGLE	1651.0	31.0	252.0	241.8
		351	P255/70R16	6400	SINGLE	1651.0	31.0	268.0	243.8
K15953		356	P245/75R16	6400	SINGLE	1651.0	31.0	261.0	249.7
		364	LT245/75R16	6400	SINGLE	1651.0	28.0	256.0	257.7
		373	P265/75R16	6400	SINGLE	1651.0	31.0	276.0	266.7
C25743		365	LT245/75R16	9200	SINGLE	1742.0	28.0	256.0	238.3
k25743		364	LT245/75R16	9200	SINGLE	1742.0	28.0	256.0	237.3
	&VYU	365	LT245/75R16	9200	SINGLE	1742.0	28.0	256.0	238.3
C25753		365	LT245/75R16	9200	SINGLE	1742.0	28.0	256.0	238.3
K25753		364	LT245/75R16	8600	SINGLE	1742.0	28.0	256.0	237.3
	&VYU	365	LT245/75R16	8600	SINGLE	1742.0	28.0	256.0	238.3
		365	LT245/75R16	9200	SINGLE	1742.0	28.0	256.0	238.3
	&VYU	366	LT245/75R16	9200	SINGLE	1742.0	28.0	256.0	239.3
C25903		365	LT245/75R16	8500	SINGLE	1742.0	28.0	256.0	238.3
	&E63	366	LT245/75R16	8600	SINGLE	1742.0	28.0	256.0	239.3
	&ZW9	366	LT245/75R16	8600	SINGLE	1742.0	28.0	256.0	239.3
	&E63	366	LT245/75R16	9200	SINGLE	1742.0	28.0	256.0	239.3
	&ZW9	366	LT245/75R16	9200	SINGLE	1742.0	28.0	256.0	239.3
K25903		365	LT245/75R16	8500	SINGLE	1742.0	28.0	256.0	238.3
	&ZW9	365	LT245/75R16	9200	SINGLE	1742.0	28.0	256.0	238.3
	&E63	366	LT245/75R16	9200	SINGLE	1742.0	28.0	256.0	239.3
	&ZW9&VYU	366	LT245/75R16	9200	SINGLE	1742.0	28.0	256.0	239.3
	&E63&VYU	366	LT245/75R16	9200	SINGLE	1742.0	28.0	256.0	239.3

C/K (25HD/35/36) Front Axle/Tire Data

SERIES	OPT	SLR	TIRES	GVW RATING	REAR WHEEL	TRACK	WHEEL OFFSET	MAX TIRE WIDTH	GROUND CLEARANCE
C25906		366	LT245/75R16	8600	SINGLE	1742.0	28.0	256.0	239.3
	&NYS	365	LT265/75R16	8600	SINGLE	1742.0	28.0	256.0	238.3
K25906		364	LT245/75R16	8600	SINGLE	1742.0	28.0	256.0	237.3
	&NYS	364	LT245/75R16	8600	SINGLE	1742.0	28.0	256.0	237.3
C25936		365	LT245/75R16	6800	SINGLE	1742.0	28.0	256.0	238.3
K25936		364	LT245/75R16	6800	SINGLE	1742.0	28.0	256.0	237.3
C25943	&E63	365	LT245/75R16	9200	SINGLE	1742.0	28.0	256.0	238.3
	&ZW9	365	LT245/75R16	9200	SINGLE	1742.0	28.0	256.0	238.5
K25943	&E63	365	LT245/75R16	9200	SINGLE	1742.0	28.0	256.0	238.3
	&ZW9	365	LT245/75R16	9200	SINGLE	1742.0	28.0	256.0	238.3
C25953		365	LT245/75R16	8500	SINGLE	1742.0	28.0	256.0	238.3
		365	LT245/75R16	9200	SINGLE	1742.0	28.0	256.0	238.3
K25953		363	LT245/75R16	8600	SINGLE	1742.0	28.0	256.0	236.3
		364	LT245/75R16	9200	SINGLE	1742.0	28.0	256.0	237.3
	&VYU	365	LT245/75R16	9200	SINGLE	1742.0	28.0	256.0	238.3

GMT800, C/K (15/25/35/36), 2004, FRONT AXLE/TIRE DATA

C/K (25HD/35/36) Front Axle/Tire Data

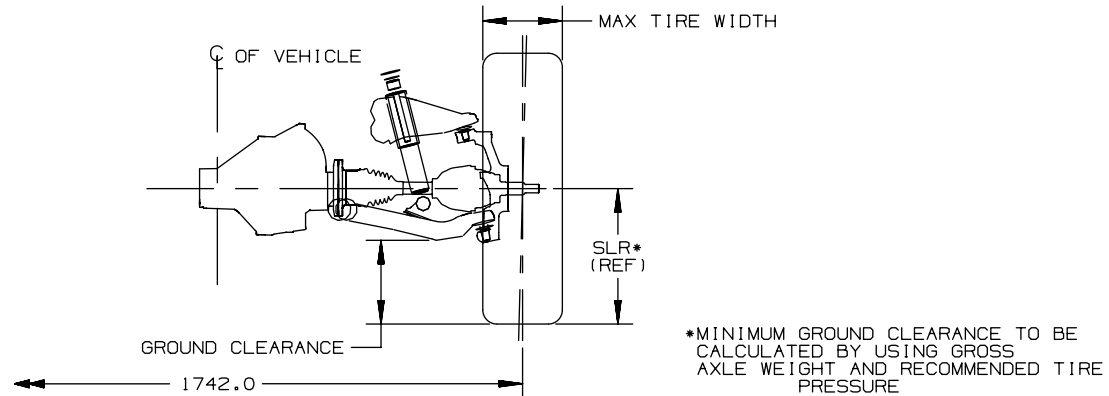

SERIES	OPT	SLR	TIRES	GVW RATING	REAR WHEEL	TRACK	WHEEL OFFSET	MAX TIRE WIDTH	GROUND CLEARANCE
K35903	&E63	365	LT215/85R16	11400	DUAL	1742.0	128.0	227.0	218.3
	&ZW9	365	LT215/85R16	11400	DUAL	1742.0	128.0	227.0	218.3
	&E63&VYU	367	LT215/85R16	11400	DUAL	1742.0	128.0	227.0	220.3
	&ZW97VYU	367	LT215/85R16	11400	DUAL	1742.0	128.0	227.0	220.3
C35943	&E63	365	LT215/85R16	11400	DUAL	1742.0	128.0	227.0	218.3
	&ZW9	365	LT215/85R16	11400	DUAL	1742.0	128.0	227.0	218.3
K35943	&E63	365	LT215/85R16	11400	DUAL	1742.0	128.0	227.0	218.3
	&ZW9	365	LT215/85R16	11400	DUAL	1742.0	128.0	227.0	218.3
C35953		365	LT215/85R16	11400	DUAL	1742.0	128.0	227.0	218.3
K35953		366	LT215/85R16	11400	DUAL	1742.0	128.0	227.0	219.3
C36003		366	LT215/85R16	11400	DUAL	1742.0	128.0	227.0	219.3
K36003		365	LT215/85R16	12000	DUAL	1742.0	128.0	227.0	218.3
	&VYU	367	LT215/85R16	12000	DUAL	1742.0	128.0	227.0	220.3
C36053		365	LT215/85R16	11400	DUAL	1742.0	128.0	227.0	218.3
K36053		365	LT215/85R16	12000	DUAL	1742.0	128.0	227.0	218.3
C36403		365	LT215/85R16	11400	DUAL	1742.0	128.0	227.0	218.3
K36403		366	LT215/85R16	12000	DUAL	1742.0	128.0	227.0	219.3
K35903		TBD	TBD	9900	SINGLE	TBD	TBD	TBD	TBD
K35943		TBD	TBD	9900	SINGLE	TBD	TBD	TBD	TBD
K35953		TBD	TBD	9900	SINGLE	TBD	TBD	TBD	TBD

C/K (15/25) Rear Axle/Tire Data

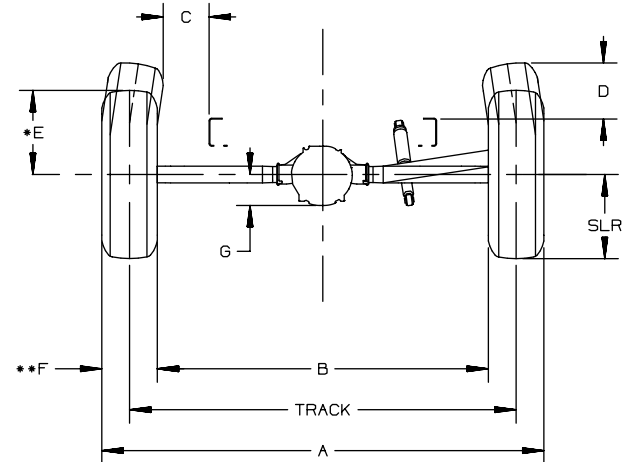
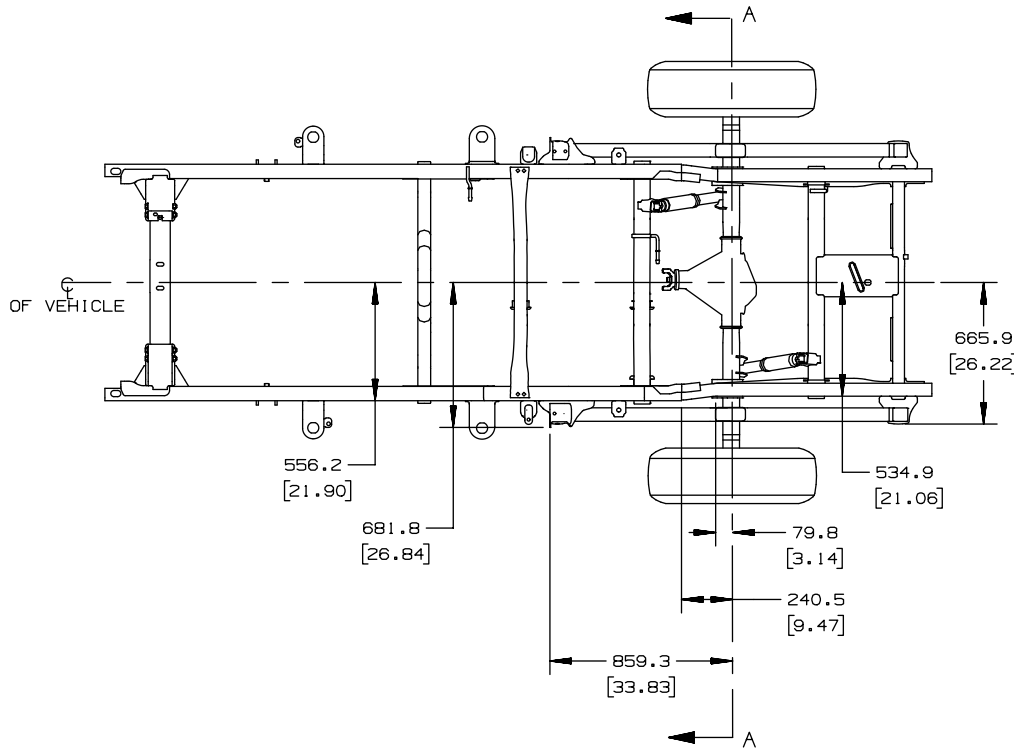

SECTION A-A
ROTATED 90

A = TRACK + F
B = TRACK - F

- * MAX GROWN TIRE RADIUS ON NARROWEST RIM
- ** MAX GROWN TIRE WIDTH ON WIDEST RIM
TIRE CHAINS NOT INCLUDED

RING GEAR	G
[8.6] DIA	142.2 [5.60]
[9.5] DIA	166.3 [6.55]
[10.5] DIA	185.0 [7.28]
[11.5] DIA	191.5 [7.54]

C/K (15/25), 2004 REAR AXLE/TIRE DATA

[] = INCHES

2005 & BEYOND C/K FULL SIZE TRUCKS (PICKUPS, UTILITIES AND CHASSIS-CABS)

C/K (15) Rear Axle/Tire Data Chart

SERIES	OPT	SLR	TIRES	GVW RATING	REAR WHEEL	TRACK	WHEEL OFFSET	-A-	-B-	-C-	-D-	-E-	-F-
C15543		358	P255/70R16	6800	SINGLE	1676.4	31.0	1944.4	1408.4	125.6	232.7	388.0	268.0
K15543		380	P265/70R17	7000	SINGLE	1676.4	31.0	1956.4	1396.4	112.2	236.0	410.0	281.0
C15703		360	P235/75R16	6100	SINGLE	1676.4	31.0	1928.4	1424.4	116.4	282.6	385.0	252.0
		362	P255/70R16	6100	SINGLE	1676.4	31.0	1944.4	1408.4	108.2	286.7	388.0	268.0
		TBD	TBD	6700	SINGLE	1676.4	TBD	TBD	TBD	TBD	TBD	TBD	TBD
K15703		368	P245/75R16	6400	SINGLE	1676.4	31.0	1937.4	1415.4	125.0	219.6	393.0	261.0
		372	LT245/75R16	6400	SINGLE	1676.4	28.0	1932.4	1420.4	127.6	218.5	396.0	256.0
		383	P265/75R16	6400	SINGLE	1676.4	31.0	1952.4	1400.4	115.9	234.9	410.0	276.0
C15706		363	P245/75R16	6500	SINGLE	1676.4	31.0	1937.4	1415.4	41.9	216.0	393.0	261.0
		364	P265/70R16	6500	SINGLE	1676.4	31.0	1952.4	1400.4	33.9	215.7	395.0	276.0
		362	P245/75R16	6800	SINGLE	1676.4	31.0	1937.4	1415.4	41.9	216.0	393.0	261.0
		363	P265/70R16	6800	SINGLE	1676.4	31.0	1952.4	1400.4	33.9	215.7	395.0	276.0
	&Z75	374	P265/70R17	6800	SINGLE	1676.4	31.0	1957.4	1395.4	29.7	232.2	410.0	281.0
K15706	FGAWR 3350	374	P265/70R17	6800	SINGLE	1676.4	31.0	1957.4	1395.4	29.7	232.2	410.0	281.0
		378	P265/75R16	6800	SINGLE	1676.4	31.0	1952.4	1400.4	33.3	230.9	410.0	276.0
		367	LT245/75R16	6800	SINGLE	1676.4	28.0	1932.4	1420.4	44.5	214.8	396.0	256.0
	FGAWR 3600	362	P245/75R16	6800	SINGLE	1676.4	31.0	1937.4	1415.4	41.9	216.0	393.0	261.0
		378	P265/75R16	6800	SINGLE	1676.4	31.0	1952.4	1400.4	33.3	230.9	410.0	276.0
		364	P265/70R16	6800	SINGLE	1676.4	31.0	1952.4	1400.4	33.9	215.7	395.0	276.0
		367	LT245/75R16	6800	SINGLE	1676.4	28.0	1932.4	1420.4	44.5	214.8	396.0	256.0
		361	P245/75R16	6900	SINGLE	1676.4	31.0	1937.4	1415.4	41.9	216.0	393.0	261.0
		363	P265/70R16	6900	SINGLE	1676.4	31.0	1952.4	1400.4	33.9	215.7	395.0	276.0
C15743		374	P265/70R17	7000	SINGLE	1676.4	31.0	1957.4	1395.4	31.8	231.2	410.0	281.0
	&NYS	373	LT245/75R16	8600	SINGLE	1676.4	28.0	1932.4	1420.4	117.7	260.4	396.0	256.0
K15743		373	LT245/75R16	8600	SINGLE	1802.4	28.0	2062.2	1550.2	200.2	235.8	396.0	256.0
	&NYS	373	LT245/75R16	8600	SINGLE	1802.4	28.0	2062.2	1550.2	200.2	235.8	396.0	256.0
C15753		358	P235/75R16	6200	SINGLE	1676.4	28.0	1928.4	1424.4	120.7	251.6	385.0	252.0
		361	P255/70R16	6200	SINGLE	1676.4	28.0	1944.4	1408.4	112.5	255.1	388.0	268.0
		370	LT245/75R16	6200	SINGLE	1676.4	28.0	1932.4	1420.4	117.7	260.5	396.0	256.0
	&NYS	357	P255/70R16	6600	SINGLE	1802.4	31.0	2070.2	1534.2	194.8	230.2	388.0	268.0

NYS=STEERING FOUR WHEEL

C/K (15/25), 2004 REAR AXLE/TIRE DATA

[]= INCHES

TD006069b

2005 & BEYOND C/K FULL SIZE TRUCKS (PICKUPS, UTILITIES AND CHASSIS-CABS)

C/K (15) Rear Axle/Tire Data Chart

SERIES	OPT	SLR	TIRES	GVW RATING	REAR WHEEL	TRACK	WHEEL OFFSET	- A -	- B -	- C -	- D -	- E -	- F -
K15753		368	P245/75R16	6400	SINGLE	1676.4	31.0	1937.4	1415.4	125.0	219.9	393.0	261.0
		372	LT245/75R16	6400	SINGLE	1676.4	28.0	1932.4	1420.4	127.6	218.7	396.0	256.0
		383	P265/75R16	6400	SINGLE	1676.4	31.0	1952.4	1400.4	115.9	235.0	410.0	276.0
		390	P275/55R20	6400	SINGLE	1676.4	40.0	1964.4	1388.4	100.3	241.8	405.0	288.0
	&NYS	364	P245/75R16	6900	SINGLE	1802.4	31.0	2063.4	1541.4	197.6	237.1	393.0	261.0
	&NYS	369	LT245/75R16	6900	SINGLE	1802.4	31.0	2058.4	1546.4	200.2	236.0	396.0	256.0
	&NYS	380	P265/75R16	6900	SINGLE	1802.4	31.0	2078.4	1526.4	188.8	252.2	410.0	276.0
C15903		379	P265/70R17	7200	SINGLE	1802.4	31.0	2083.4	1521.4	185.2	252.9	410.0	281.0
		359	P235/75R16	6400	SINGLE	1676.4	31.0	1928.4	1424.4	116.4	282.2	385.0	252.0
K15903		362	P255/70R16	6400	SINGLE	1676.4	31.0	1944.4	1408.4	108.2	285.7	388.0	268.0
		368	P245/75R16	6400	SINGLE	1676.4	31.0	1937.4	1415.4	124.9	218.5	393.0	261.0
C15906		372	LT245/75R16	6400	SINGLE	1676.4	28.0	1932.4	1420.4	127.4	217.4	396.0	256.0
		384	P265/75R16	6400	SINGLE	1676.4	31.0	1952.4	1400.4	115.8	233.7	410.0	276.0
K15906		363	P245/75R16	7000	SINGLE	1676.4	31.0	1937.4	1415.4	41.9	177.2	393.0	261.0
		363	P265/70R16	7000	SINGLE	1676.4	31.0	1952.4	1400.4	34.5	177.2	395.0	276.0
K15906	FGAWR3600	363	P245/75R16	7200	SINGLE	1676.4	31.0	1937.4	1415.4	41.9	177.2	393.0	261.0
		364	P265/70R16	7200	SINGLE	1676.4	31.0	1952.4	1400.4	34.5	177.2	395.0	276.0
	FGAWR3550	375	P265/70R17	7200	SINGLE	1676.4	31.0	1957.4	1395.4	29.6	193.2	410.0	281.0
	FGAWR3450	375	P265/70R17	7200	SINGLE	1676.4	31.0	1957.4	1395.4	29.6	193.2	410.0	281.0
C15936	&ZQ1	360	P245/75R16	6800	SINGLE	1676.4	31.0	1937.4	1415.4	41.9	177.2	393.0	261.0
		361	P265/70R16	6800	SINGLE	1676.4	31.0	1952.4	1400.4	34.5	177.2	395.0	276.0
	&ZW7	374	P265/70R17	6800	SINGLE	1676.4	31.0	1957.4	1395.4	29.6	193.2	410.0	281.0
K15936	&ZQ1	361	P265/70R16	7000	SINGLE	1676.4	31.0	1952.4	1400.4	34.5	177.2	395.0	276.0
	&Z71	371	P265/70R17	7000	SINGLE	1676.4	31.0	1957.4	1395.4	29.6	193.2	410.0	281.0
	&Z75	373	P265/70R17	7000	SINGLE	1676.4	31.0	1957.4	1395.4	29.6	193.2	410.0	281.0
C15953		358	P235/75R16	6400	SINGLE	1676.4	31.0	1928.4	1424.4	120.6	251.4	385.0	252.0
		361	P255/70R16	6400	SINGLE	1676.4	31.0	1944.4	1408.4	112.4	254.8	388.0	268.0
K15953		367	P245/75R16	6400	SINGLE	1676.4	31.0	1937.4	1415.4	124.9	219.5	393.0	261.0
		371	LT245/75R16	6400	SINGLE	1676.4	28.0	1932.4	1420.4	127.5	218.4	396.0	256.0
		383	P265/75R16	6400	SINGLE	1676.4	31.0	1952.4	1400.4	115.8	234.6	410.0	276.0

NYS=STEERING FOUR WHEEL
C/K(15/25),2004 REAR AXLE/TIRE DATA

[]= INCHES

2005 & BEYOND C/K FULL SIZE TRUCKS (PICKUPS, UTILITIES AND CHASSIS-CABS)

C/K (25) Rear Axle/Tire Data Chart

SERIES	OPT	SLR	TIRES	GVW RATING	REAR WHEEL	TRACK	WHEEL OFFSET	-A-	-B-	-C-	-D-	-E-	-F-
C25743		373	LT245/75R16	9200	SINGLE	1676.4	28.0	1930.4	1420.4	113.1	208.2	396.0	256.0
K25743		373	LT245/75R16	9200	SINGLE	1676.4	28.0	1930.4	1420.4	113.1	208.2	396.0	256.0
	&VYU	373	LT245/75R16	9200	SINGLE	1676.4	28.0	1930.4	1420.4	113.1	208.2	396.0	256.0
C25753		374	LT245/75R16	9200	SINGLE	1676.4	28.0	1930.4	1420.4	113.1	208.2	396.0	256.0
K25753		374	LT245/75R16	8600	SINGLE	1676.4	28.0	1930.4	1420.4	112.6	258.2	396.0	256.0
	&VYU	374	LT245/75R16	8600	SINGLE	1676.4	28.0	1930.4	1420.4	113.1	208.2	396.0	256.0
		374	LT245/75R16	9200	SINGLE	1676.4	28.0	1930.4	1420.4	112.6	258.2	396.0	256.0
	&VYU	374	LT245/75R16	9200	SINGLE	1676.4	28.0	1930.4	1420.4	113.1	208.2	396.0	256.0
C25903		372	LT245/75R16	8500	SINGLE	1676.4	28.0	1930.4	1420.4	138.6	205.0	396.0	256.0
	&E63	375	LT245/75R16	8600	SINGLE	1676.4	28.0	1930.4	1420.4	138.6	205.0	396.0	256.0
	&ZW9	376	LT245/75R16	8600	SINGLE	1676.4	28.0	1930.4	1420.4	138.6	205.0	396.0	256.0
	&E63	374	LT245/75R16	9200	SINGLE	1676.4	28.0	1930.4	1420.4	138.6	205.0	396.0	256.0
	&ZW9	375	LT245/75R16	9200	SINGLE	1676.4	28.0	1930.4	1420.4	138.6	205.0	396.0	256.0
K25903		371	LT245/75R16	8500	SINGLE	1676.4	28.0	1930.4	1420.4	139.1	155.1	396.0	256.0
	&ZW9	375	LT245/75R16	9200	SINGLE	1676.4	28.0	1930.4	1420.4	139.1	155.1	396.0	256.0
	&E63	373	LT245/75R16	9200	SINGLE	1676.4	28.0	1930.4	1420.4	139.1	155.1	396.0	256.0
	&ZW9&VYU	375	LT245/75R16	9200	SINGLE	1676.4	28.0	1930.4	1420.4	139.1	155.1	396.0	256.0
	&E63&VYU	374	LT245/78R16	9200	SINGLE	1676.4	28.0	1930.4	1420.4	139.1	155.1	396.0	256.0
C25906		372	LT245/75R16	8600	SINGLE	1676.4	28.0	1930.4	1420.4	127.3	229.0	396.0	256.0
	&NYS	370	LT245/75R16	8600	SINGLE	1802.4	28.0	1962.2	1550.2	173.8	255.4	396.0	256.0
K25906		372	LT245/75R16	8600	SINGLE	1676.4	28.0	1930.4	1420.4	127.3	229.0	396.0	256.0
	&NYS	370	LT245/75R16	8600	SINGLE	1802.4	28.0	1962.2	1550.2	173.8	255.4	396.0	256.0
C25936		372	LT245/75R16	8600	SINGLE	1676.4	28.0	1930.4	1420.4	127.3	229.0	396.0	256.0
K25936		371	LT245/75R16	8600	SINGLE	1676.4	28.0	1930.4	1420.4	127.3	229.0	396.0	256.0
C25943	&E63	373	LT245/75R16	9200	SINGLE	1676.4	28.0	1930.4	1420.4	113.1	208.1	396.0	256.0
	&ZW9	374	LT245/75R16	9200	SINGLE	1676.4	28.0	1930.4	1420.4	113.1	208.1	396.0	256.0
K25943	&E63	372	LT245/75R16	9200	SINGLE	1676.4	28.0	1930.4	1420.4	113.1	208.1	396.0	256.0
	&ZW9	374	LT245/75R16	9200	SINGLE	1676.4	28.0	1930.4	1420.4	113.1	208.1	396.0	256.0
C25953		371	LT245/75R16	8500	SINGLE	1676.4	28.0	1930.4	1420.4	113.1	208.1	396.0	256.0
		374	LT245/75R16	9200	SINGLE	1676.4	28.0	1930.4	1420.4	113.1	208.1	396.0	256.0
K25953		371	LT245/75R16	8500	SINGLE	1676.4	28.0	1930.4	1420.4	175.3	208.1	396.0	256.0
		373	LT245/75R16	9200	SINGLE	1676.4	28.0	1930.4	1420.4	175.3	208.1	396.0	256.0
	&VYU	373	LT245/75R16	9200	SINGLE	1676.4	28.0	1930.4	1420.4	175.3	208.1	396.0	256.0

C/K(15/25),2004 REAR AXLE/TIRE DATA

[] = INCHES

C/K (25HD/35) Rear Axle/Tire Data

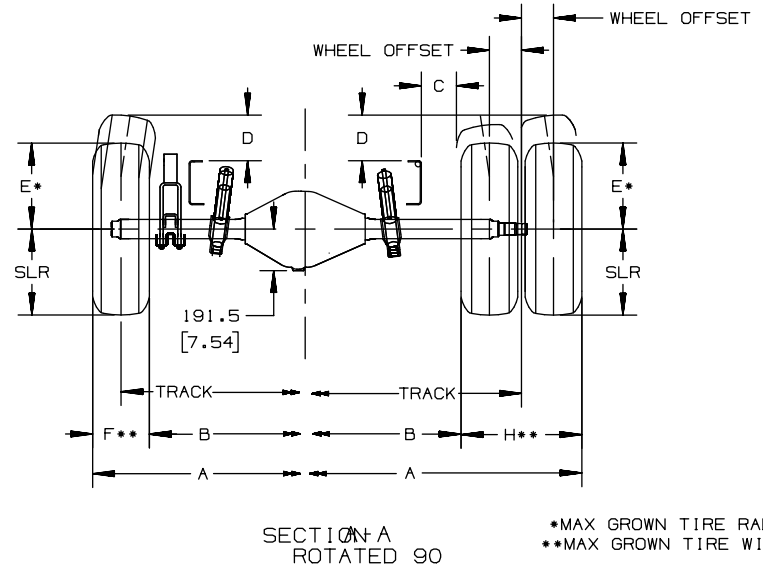
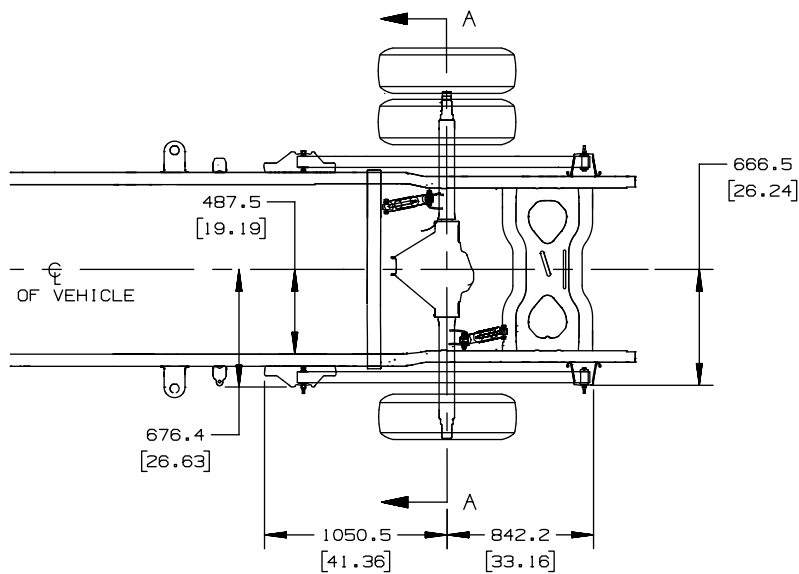

*MAX GROWN TIRE RADIUS
**MAX GROWN TIRE WIDTH

SERIES	OPT	SLR	TIRES	GVW RATING	REAR WHEEL	TRACK	WHEEL OFFSET	- A -	- B -	- C -	- D -	- E -	- F -	- H -
K35903	&E63	374	LT215/85R16	11400	DUAL	1697.0	128.0	2185.0	1209.0	TBD	TBD	393.0	N/A	488.0
	&ZW9	375	LT215/85R16	11400	DUAL	1697.0	128.0	2185.0	1209.0	TBD	TBD	393.0	N/A	488.0
	&E63&VYU	374	LT215/85R16	11400	DUAL	1697.0	128.0	2185.0	1209.0	TBD	TBD	393.0	N/A	488.0
	&ZW9&VYU	375	LT215/85R16	11400	DUAL	1697.0	128.0	2185.0	1209.0	TBD	TBD	393.0	N/A	488.0
C35943	&E63	374	LT215/85R16	11400	DUAL	1697.0	128.0	2185.0	1209.0	TBD	TBD	393.0	N/A	488.0
	&ZW9	375	LT215/85R16	11400	DUAL	1697.0	128.0	2185.0	1209.0	TBD	TBD	393.0	N/A	488.0
K35943	&E63	374	LT215/85R16	11400	DUAL	1697.0	128.0	2185.0	1209.0	TBD	TBD	393.0	N/A	488.0
	&ZW9	374	LT215/85R16	11400	DUAL	1697.0	128.0	2185.0	1209.0	TBD	TBD	393.0	N/A	488.0
C35953		374	LT215/85R16	11400	DUAL	1697.0	128.0	2185.0	1209.0	TBD	TBD	393.0	N/A	488.0
K35953		374	LT215/85R16	11400	DUAL	1697.0	128.0	2185.0	1209.0	TBD	TBD	393.0	N/A	488.0
K35903		TBD	LT265/75R16	9900	SINGLE	1697.0	28.0	1973.0	1421.0	135.2	176.4	404.0	276.0	N/A
K35943		TBD	LT265/75R16	9900	SINGLE	1697.0	28.0	1973.0	1421.0	TBD	TBD	404.0	276.0	N/A
K35953		TBD	LT265/75R16	9900	SINGLE	1697.0	28.0	1973.0	1421.0	135.2	176.4	404.0	276.0	N/A

SINGLE WHEELS
A = TRACK + F
B = TRACK - F

DUAL WHEELS
A = TRACK + H
B = TRACK - H

GMT800, C/K (35/36), 2004. REAR AXLE/TIRE DATA

MD/22AP03

[] = INCHES

TD006131a

C/K (36) Rear Axle/Tire Data

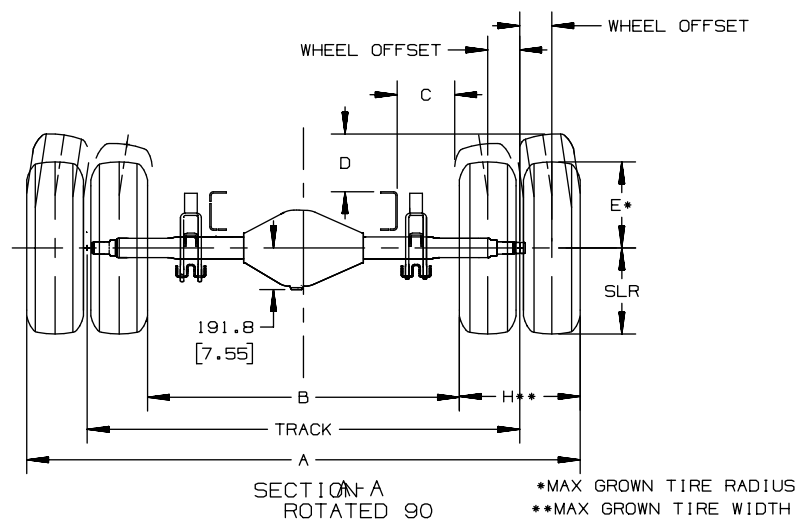
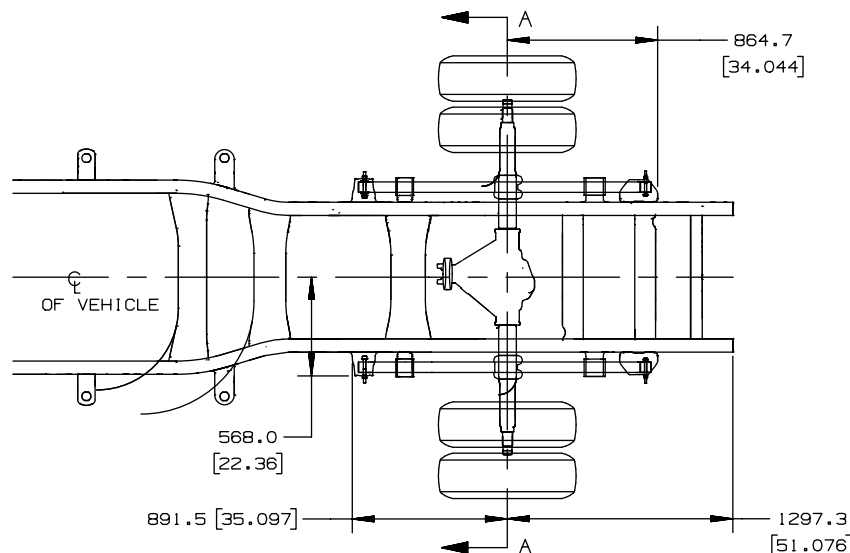

SERIES	OPT	SLR	TIRES	GVW RATING	REAR WHEEL	TRACK	WHEEL OFFSET	-A-	-B-	-C-	-D-	-E-	-H-
C36003		374	LT215/85R16	11400	DUAL	1697.0	128.0	2185.0	1209.0	TBD	TBD	393.0	488.0
K36003		374	LT215/85R16	12000	DUAL	1697.0	128.0	2185.0	1209.0	TBD	TBD	393.0	488.0
	&VYU	374	LT215/85R16	12000	DUAL	1697.0	128.0	2185.0	1209.0	TBD	TBD	393.0	488.0
C36053		374	LT215/85R16	11400	DUAL	1697.0	128.0	2185.0	1209.0	TBD	TBD	393.0	488.0
K36053		374	LT215/85R16	12000	DUAL	1697.0	128.0	2185.0	1209.0	TBD	TBD	393.0	488.0
C36403		375	LT215/85R16	11400	DUAL	1697.0	128.0	2185.0	1209.0	TBD	TBD	393.0	488.0
K36403		374	LT215/85R16	12000	DUAL	1697.0	128.0	2185.0	1209.0	TBD	TBD	393.0	488.0
C36003	>U	TBD	LT215/85R16	11400	DUAL	1897.0	128.0	2385.0	1409.0	255.7	174.7	393.0	488.0
K36003	>U	TBD	LT215/85R16	12000	DUAL	1897.0	128.0	2385.0	1409.0	255.7	174.7	393.0	488.0
C36053	>U	TBD	LT215/85R16	11400	DUAL	1897.0	128.0	2385.0	1409.0	255.7	174.7	393.0	488.0
K36053	>U	TBD	LT215/85R16	12000	DUAL	1897.0	128.0	2385.0	1409.0	255.7	174.7	393.0	488.0
C36403	>U	TBD	LT215/85R16	11400	DUAL	1897.0	128.0	2385.0	1409.0	255.7	174.7	393.0	488.0
K36403	>U	TBD	LT215/85R16	12000	DUAL	1897.0	128.0	2385.0	1409.0	255.7	174.7	393.0	488.0
C36453	>U	TBD	LT215/85R16	11400	DUAL	1897.0	128.0	2385.0	1409.0	255.7	174.7	393.0	488.0
K36453	>U	TBD	LT215/85R16	12000	DUAL	1897.0	128.0	2385.0	1409.0	255.7	174.7	393.0	488.0

DUAL WHEELS
 A=TRACK+H
 B=TRACK-H
 GTU=AXLE WIDE TRACK

GMT800, C/K (35/36), 2004. REAR AXLE/TIRE DATA

MD/22AP03

[] = INCHES

TD006131b

C/K (15/25)(7)(03/53) 26 Gallon Fuel Tank

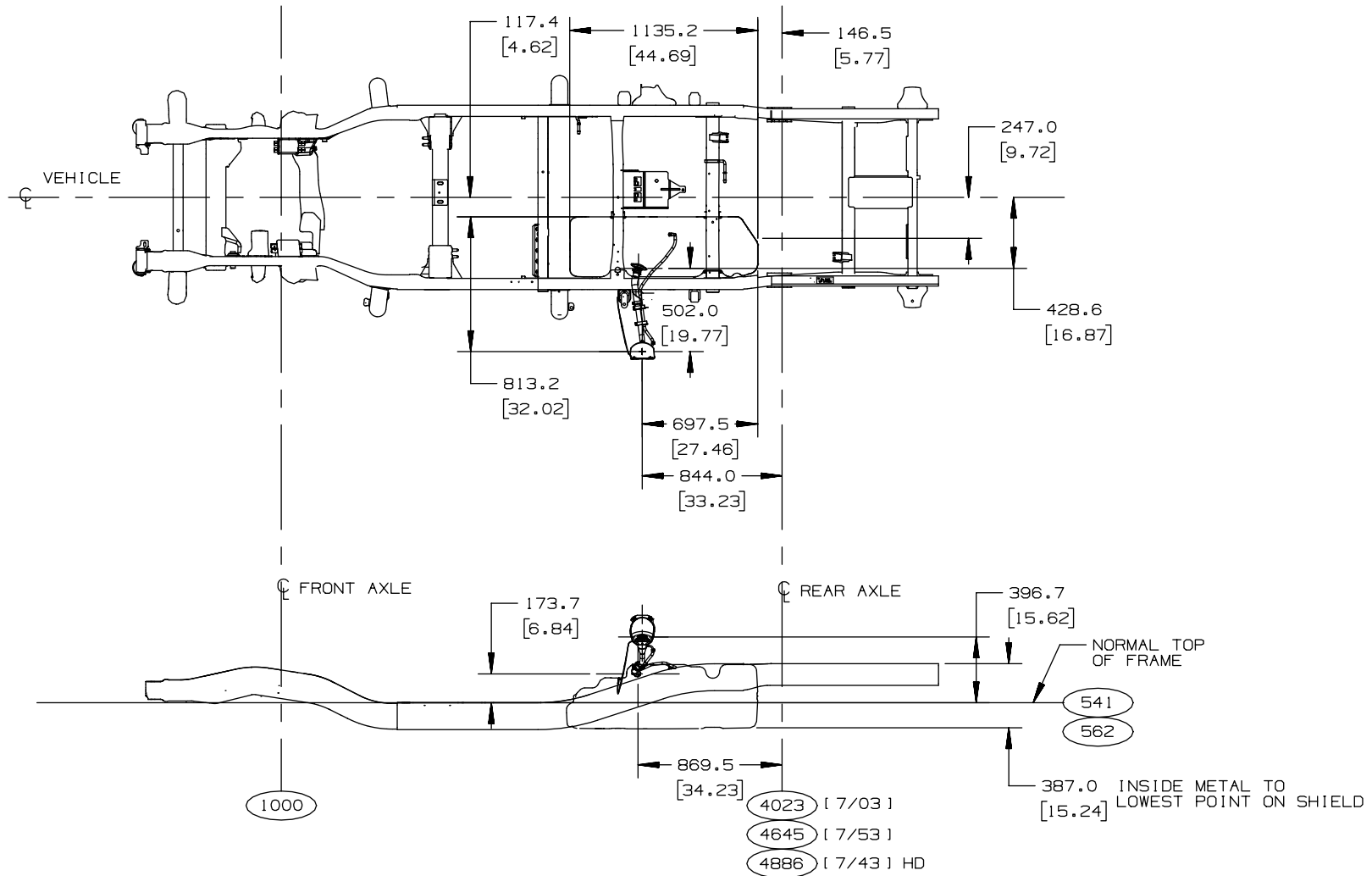

C/K (15/25) (7) (03/43/53) 26 GALLON FUEL TANK

[] = INCHES

TD006191a

C/K (15/25)(9)(03/53) 34 Gallon Fuel Tank

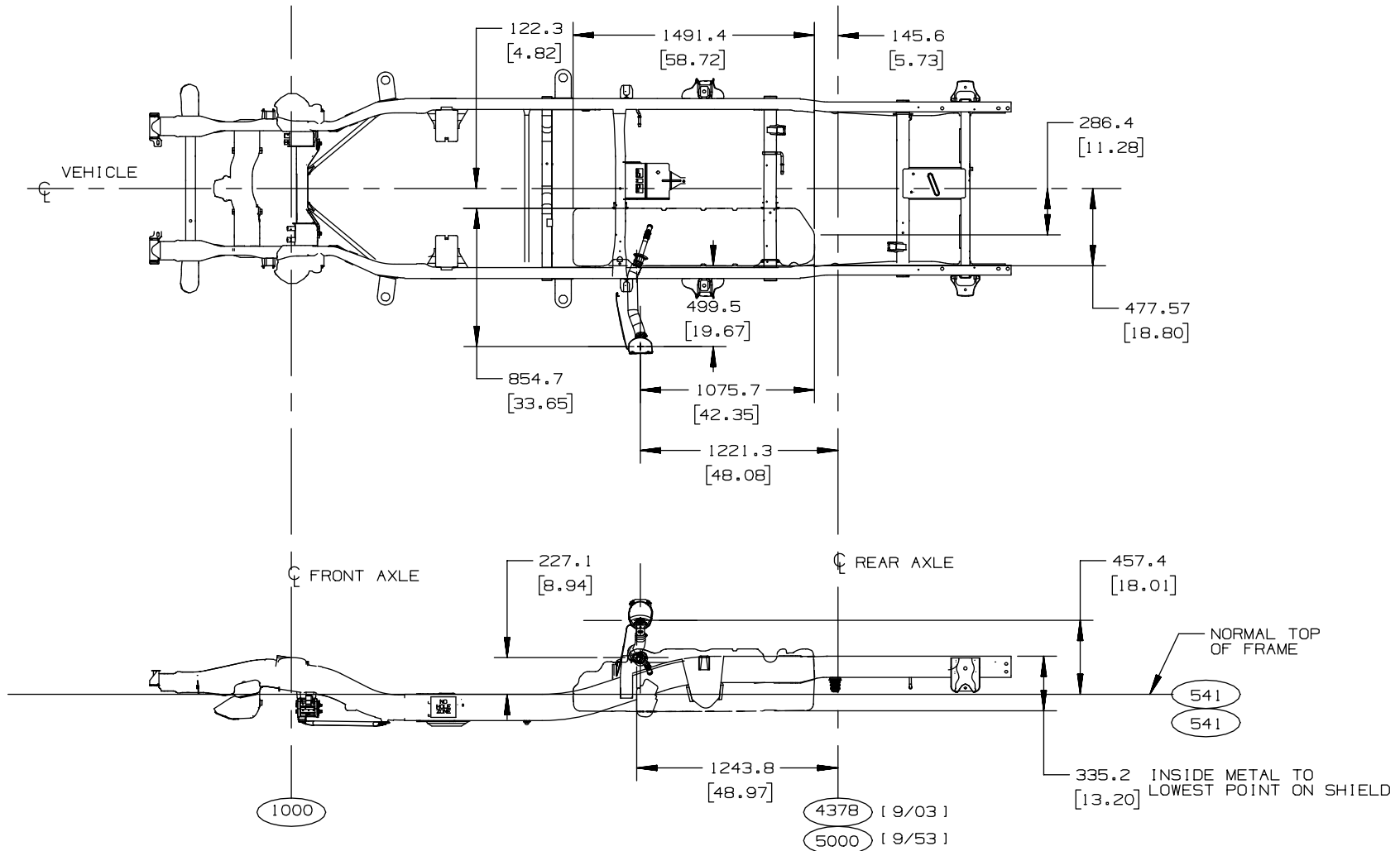

C/K (15/25)(9)(03/53) 34 GALLON FUEL TANK

[] = INCHES

TD006191b

C/K 15706 26 Gallon Fuel Tank

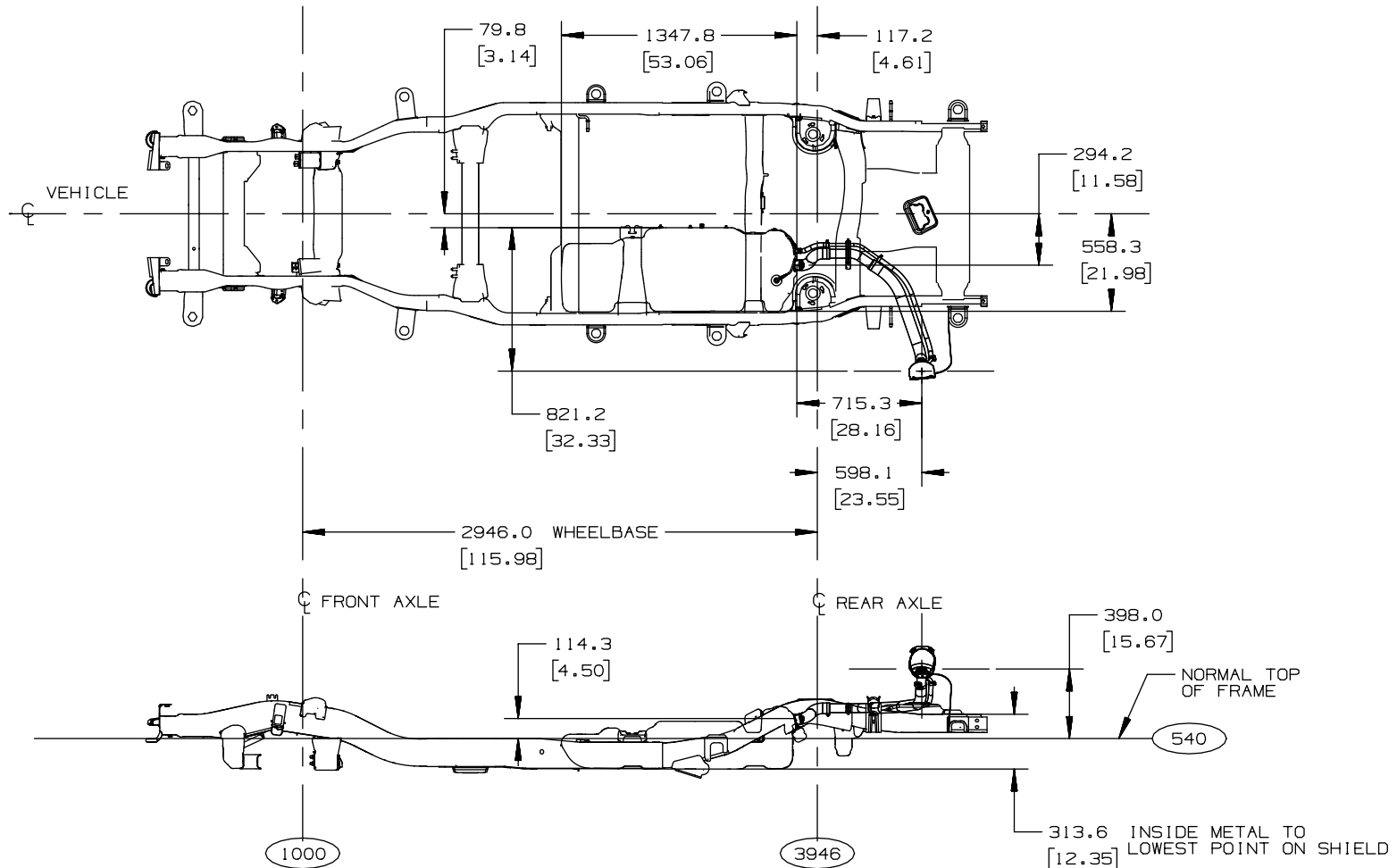

CK 157 06 26 GALLON FUEL TANK

[] = INCHES

TD006191c

C/K 15906 33 Gallon Fuel Tank

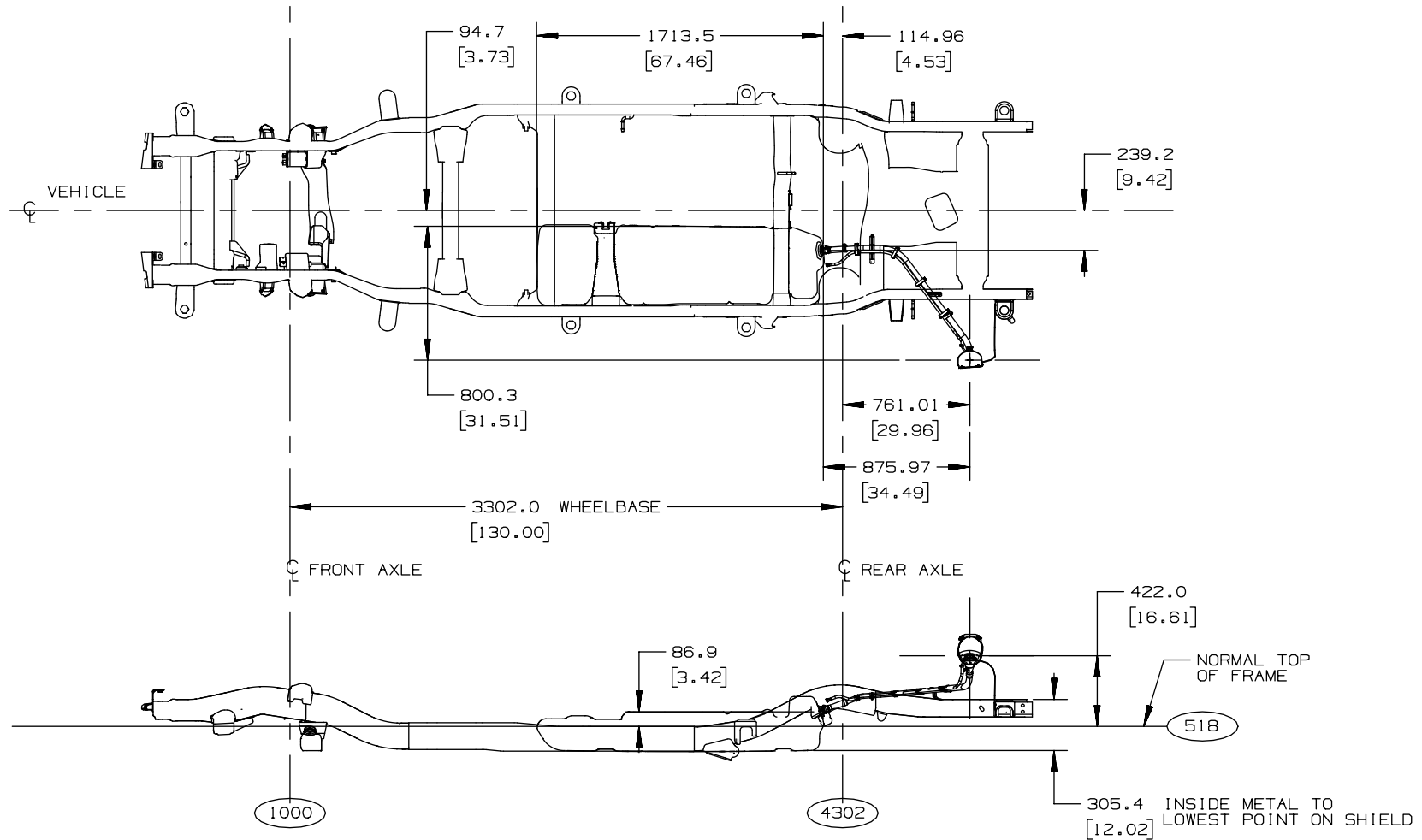

CK 159(06/36) 33 GALLON FUEL TANK

[] = INCHES

TD006191d

C/K 25(906/936) 36 Gallon Fuel Tank

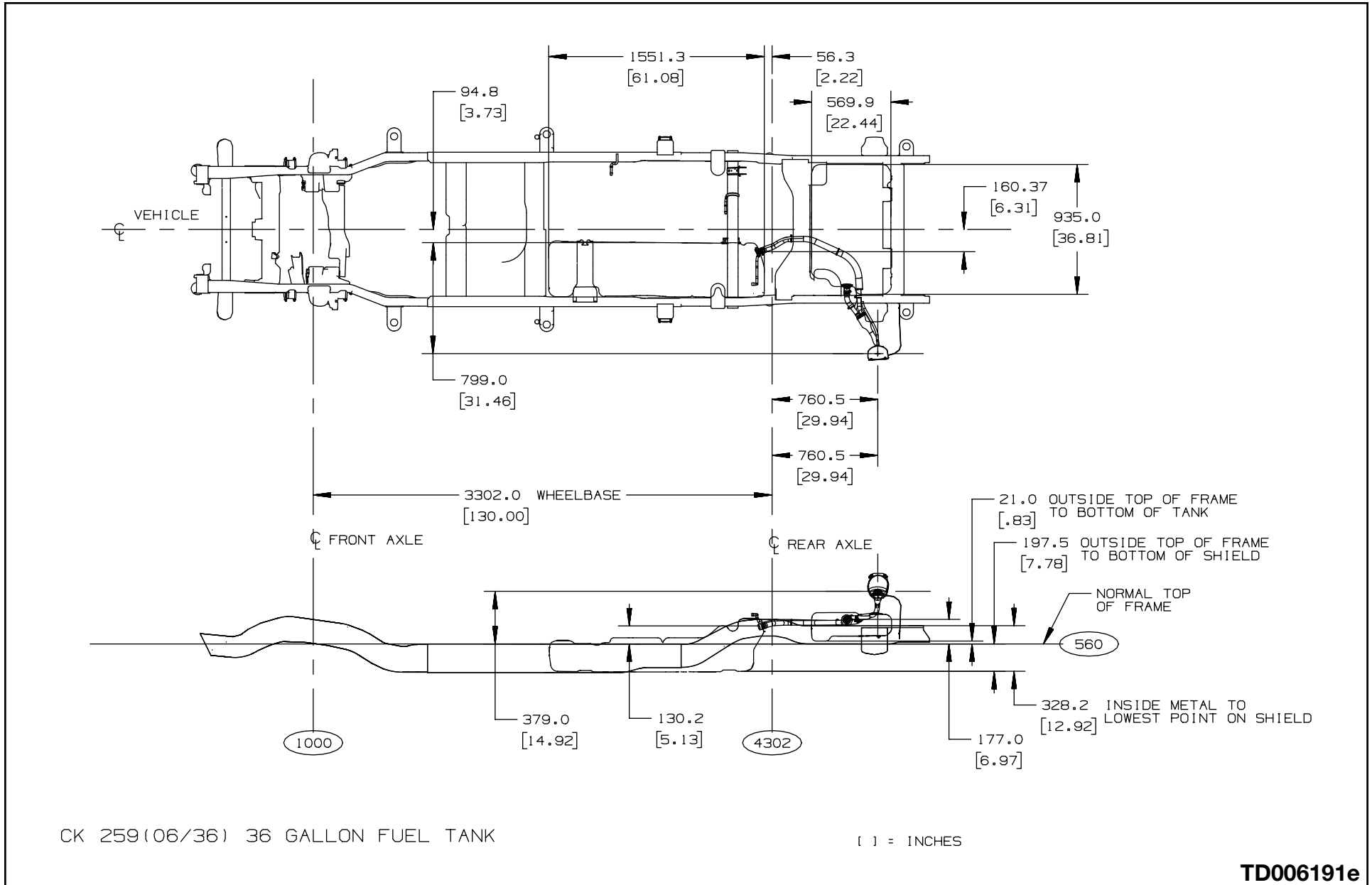

C/K (25HD/35)(9)(03/43/53) 34 Gallon Fuel Tank

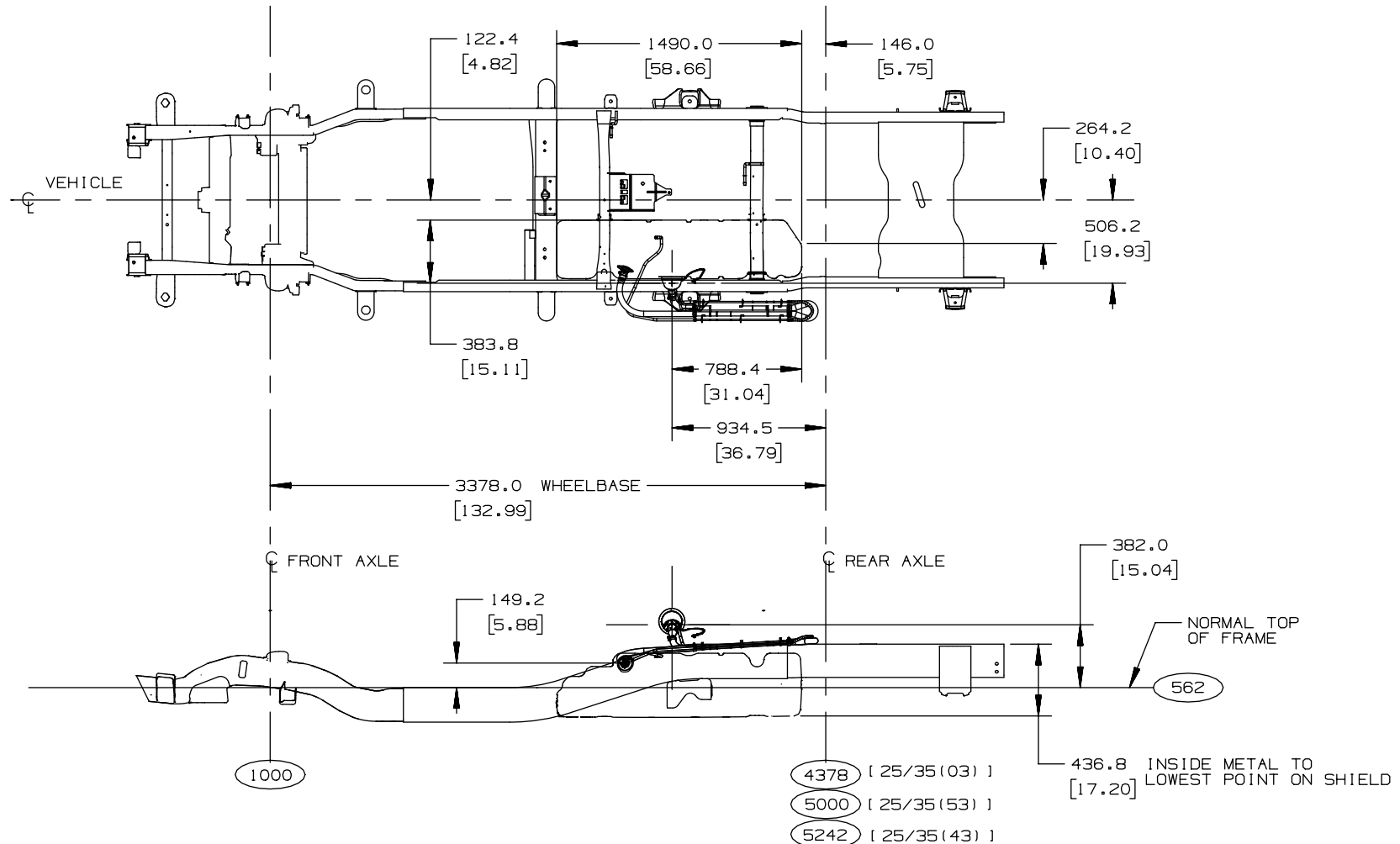

CK (25HD/35)(9)(03/43/53) 34 GALLON FUEL TANK

() = INCHES

TD006191f

2005 & BEYOND C/K FULL SIZE TRUCKS (PICKUPS, UTILITIES AND CHASSIS-CABS)

C/K (360/364)(03/53) Dual Fuel Tanks – 27 Gallon Front and 23 Gallon Rear

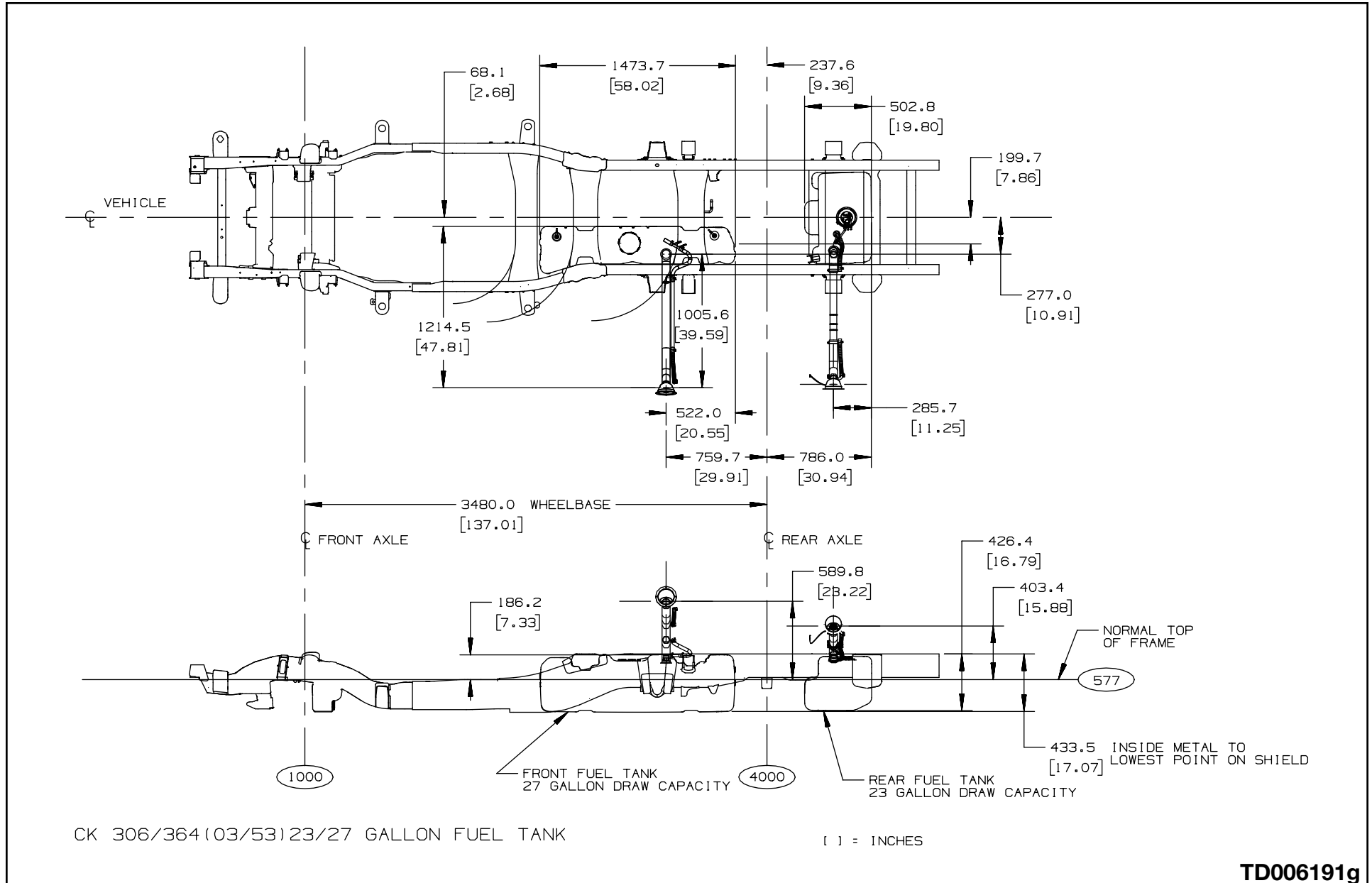

TD006191g

C/K 15543 4.3 and 4.8 L Engine and 26 Gallon Fuel Tank

CK 155 43
EXHAUST ASM.
ENGINE OPTION:
LR4/LU3 (4.8L, 4.3L)
GAS TANK
26.0 GAL. CAPACITY

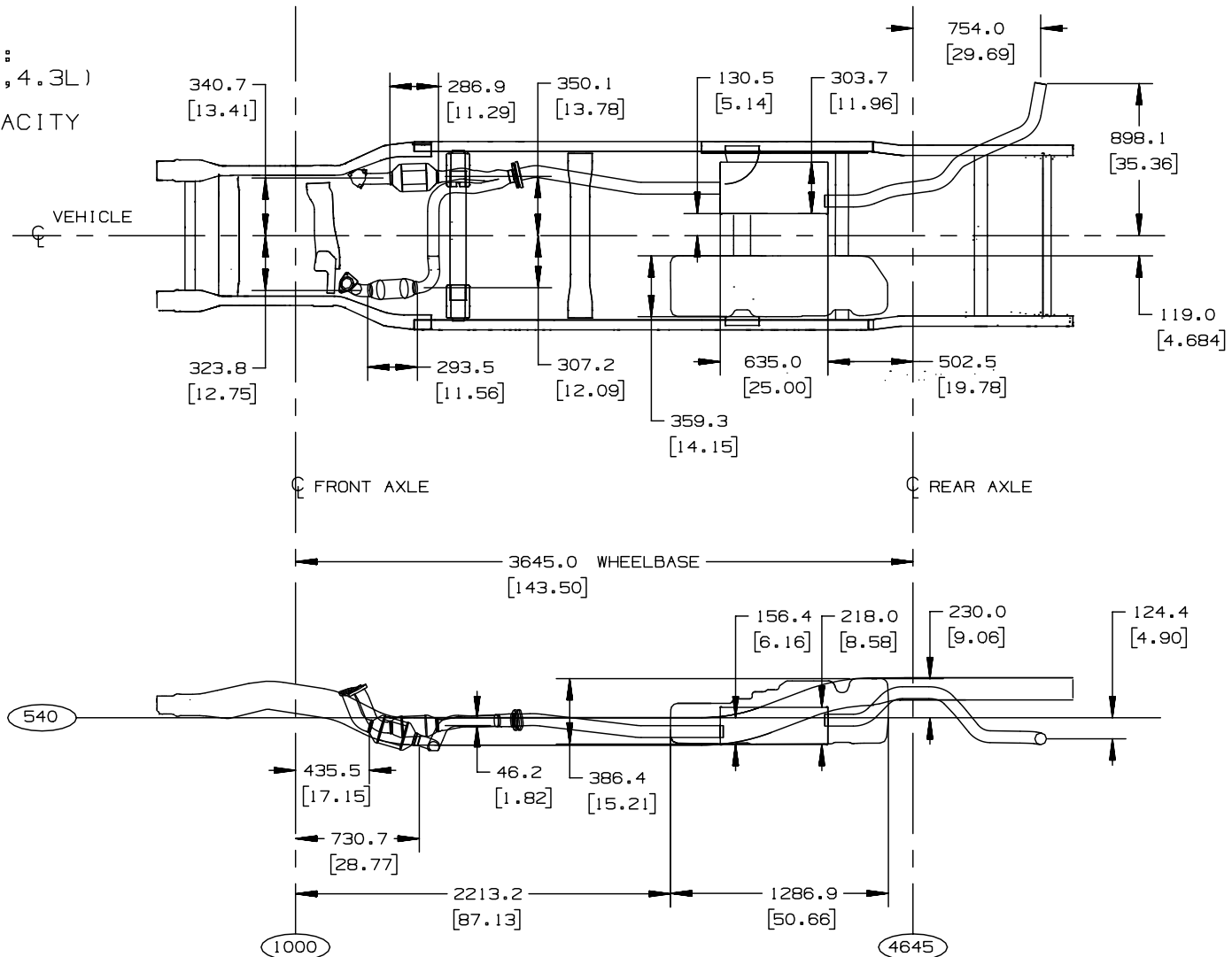

FOR: CK 800 155 43 2004 GAS TANK & EXHAUST SYSTEM

[] = INCHES

TD006156a

4.3 L V6 Gas Engine, Pickup, Option LU3 and L35

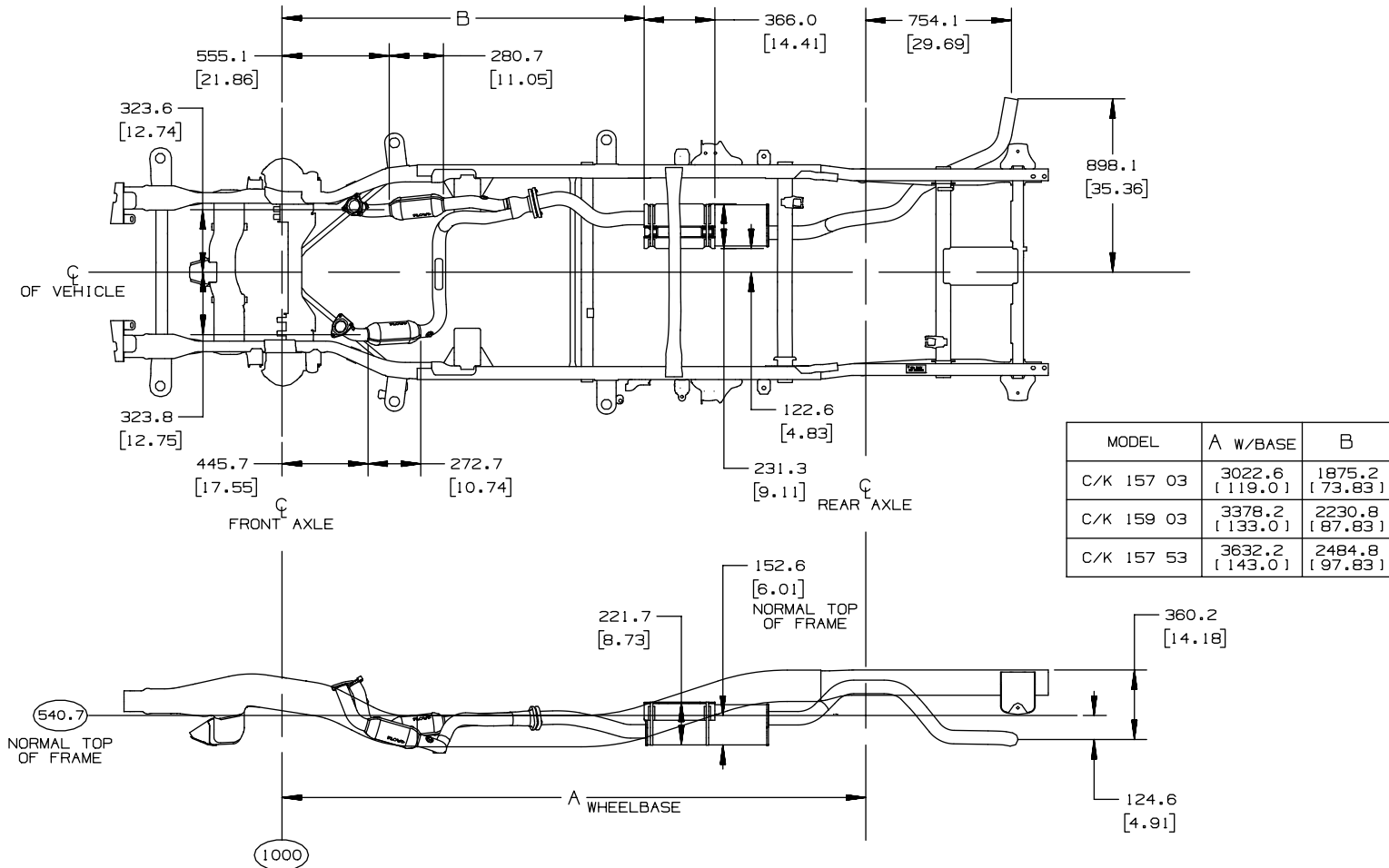

PARTS SHOWN:

FRAME ASM.
CONVERTER ASM.
MUFFLER ASM.

USAGE:

CK157 03
CK100 00 &LM7/LR4/LU3&NC1/NF4
CK157 03 &LU3/L35&NC1/NF2

ENGINE OPTION: LU3&L35 SHOWN

() = INCHES

2005 & BEYOND C/K FULL SIZE TRUCKS (PICKUPS, UTILITIES AND CHASSIS-CABS)

4.8 and 5.3 L V8 Gas Engine, Pickup, Option LR4 and LM7

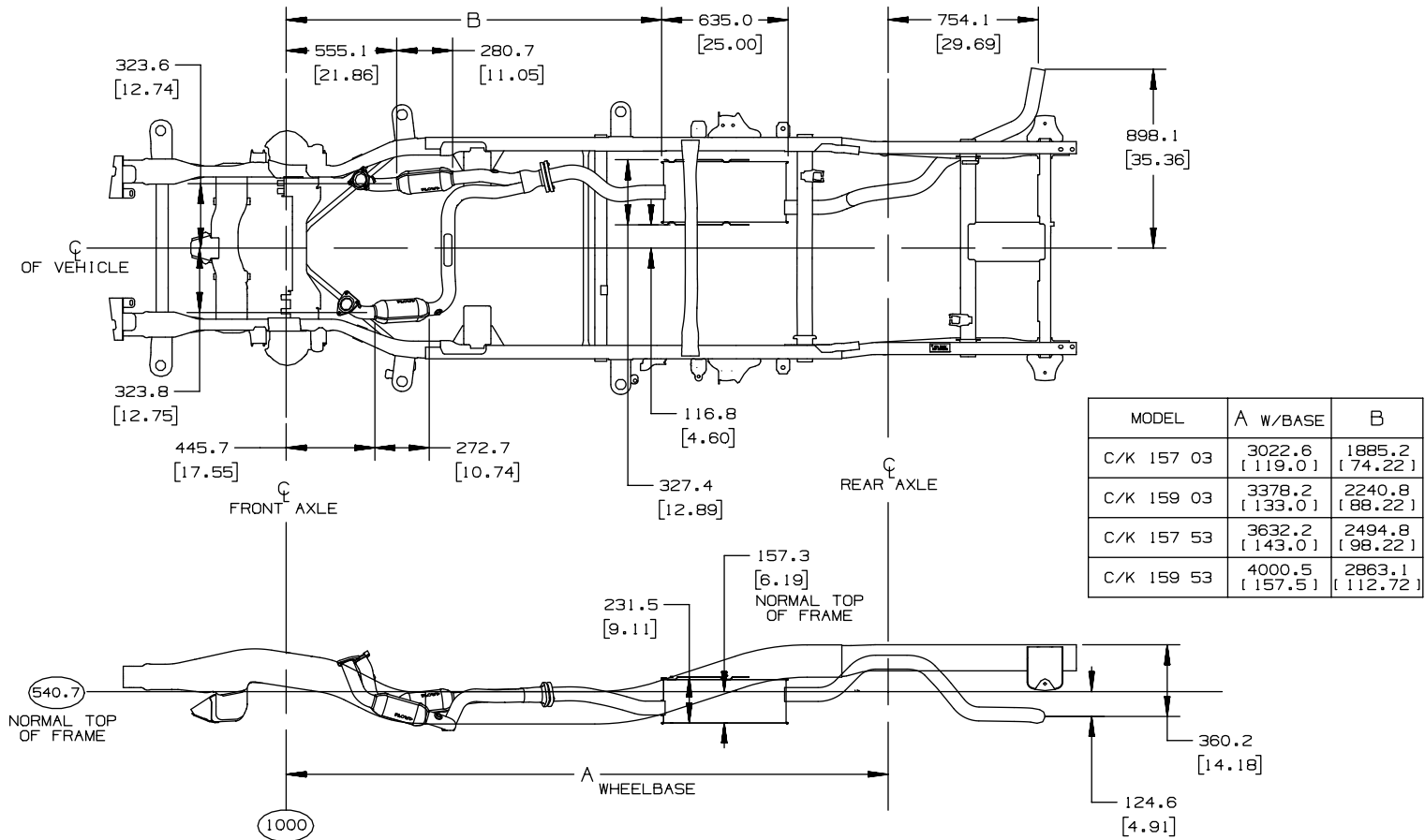

PARTS SHOWN:

FRAME ASM.
CONVERTER ASM.
MUFFLER ASM.

USAGE:

CK 157 03
CK 100 00 & LM7/LR4/L35&NF2
C 157 03 & LM7/LR4&NC1/NC8/NF2/NF4-N12

ENGINE OPTION: LR4&LM7 SHOWN

[] = INCHES

TD005984c

6.0 L V8 Gas Engine, Pickup, Option LQ4

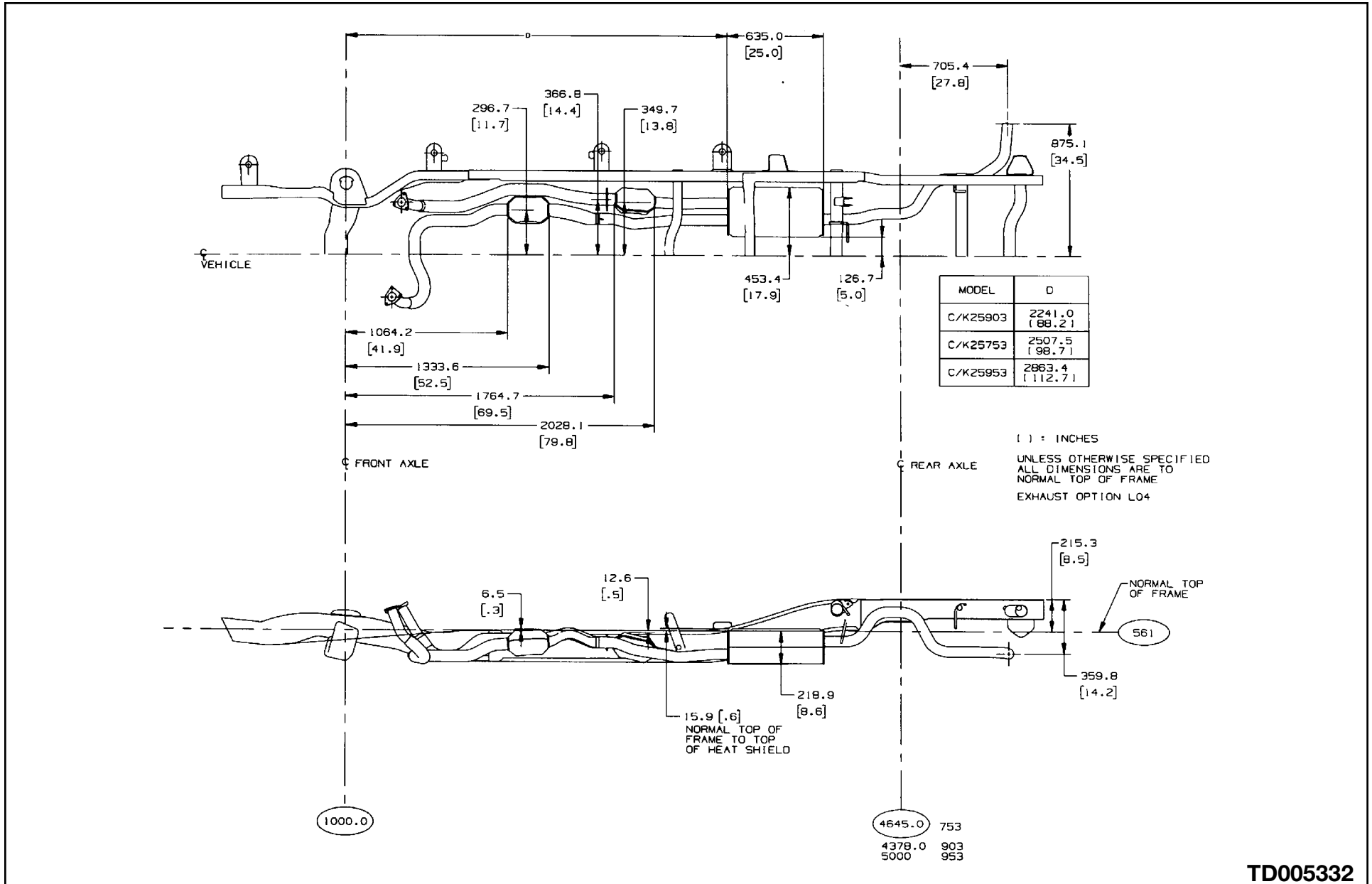

TD005332

2005 & BEYOND C/K FULL SIZE TRUCKS (PICKUPS, UTILITIES AND CHASSIS-CABS)

6.0 L V8 Gas Engine, Pickup, Option LQ4 w/NYS (Quad Steering)

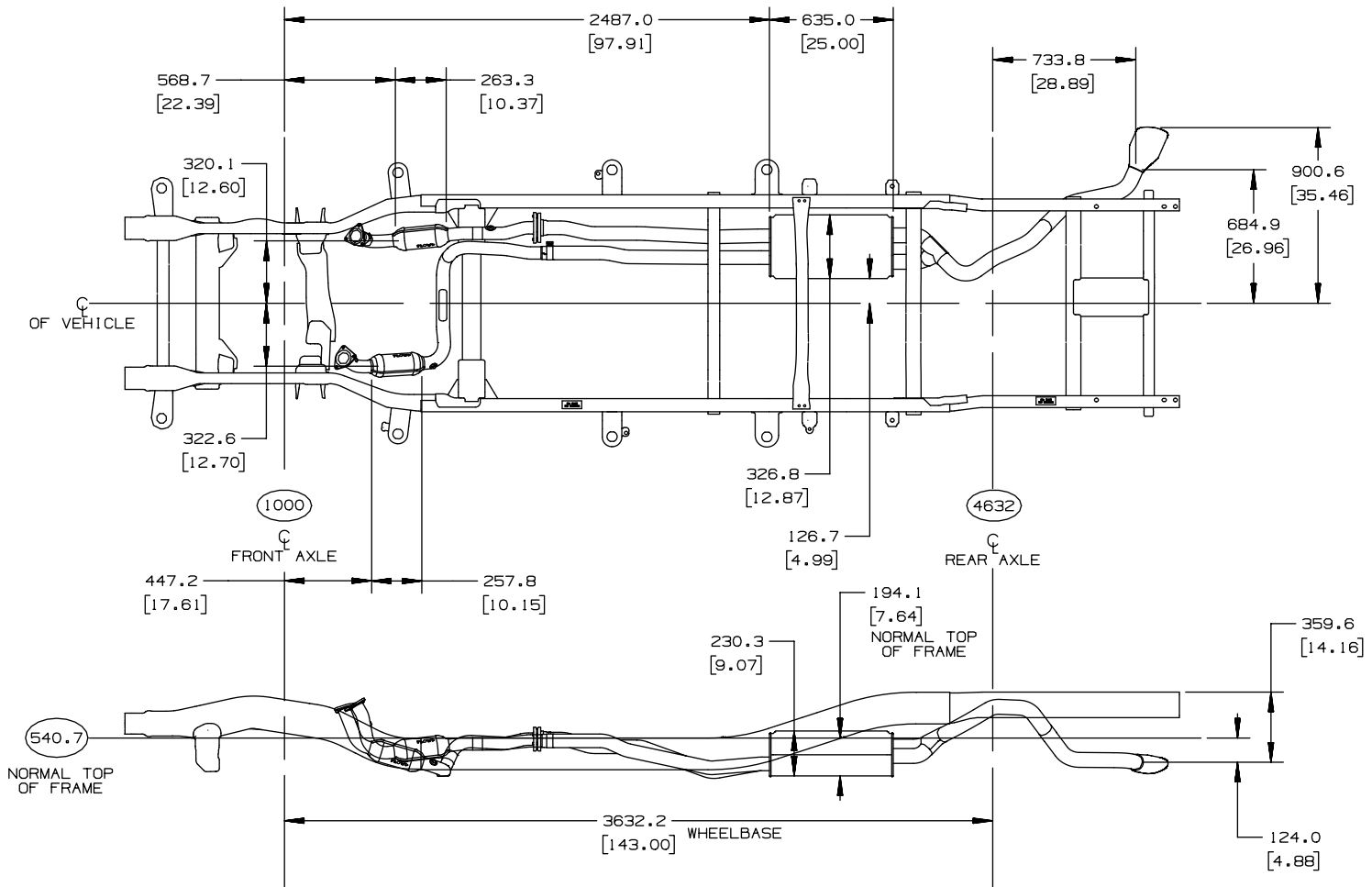

PARTS SHOWN:

FRAME ASM.
CONVERTER ASM.
MUFFLER ASM.

USAGE:

K157 53
K157 53 &LQ4/LQ9&NC1&Y91
K157 53 &LQ4/NC1/NF2&NYS&Y91

K157 53

ENGINE OPTION: LQ4 SHOWN

[] = INCHES

5.3 L V8 Gas Engine, Utility, Option LM7

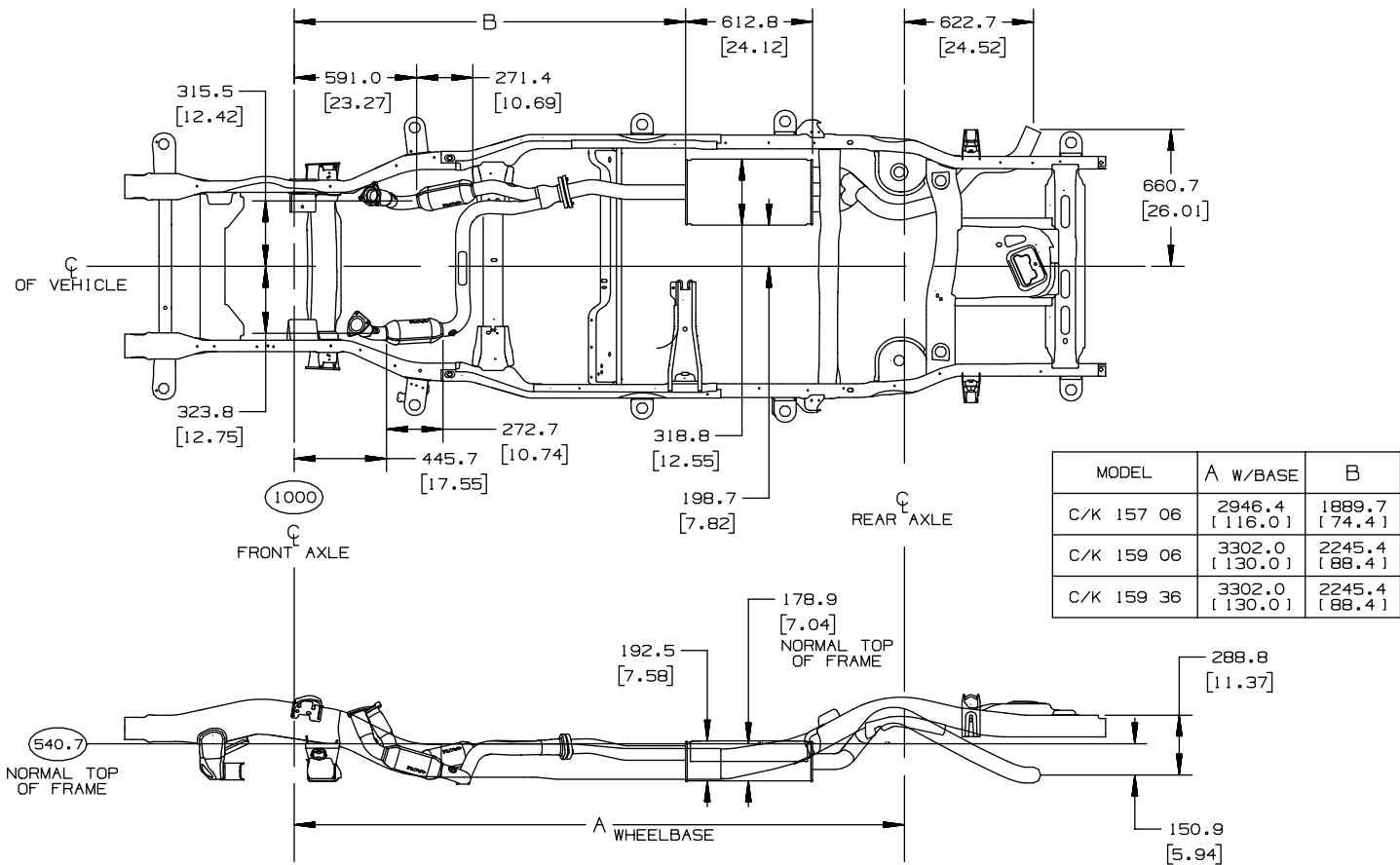

PARTS SHOWN: FRAME ASM., CONVERTER ASM., MUFFLER ASM.
 USAGE: C 157 06, CK100 00, C 157 06, &LM7&NCB/NT3, &LM7&NCB/NF2&Y91

ENGINE OPTION: LM7 SHOWN

[] = INCHES

TD005984b

6.0 L V8 Gas Engine, Utility, Option LQ4 and LQ9

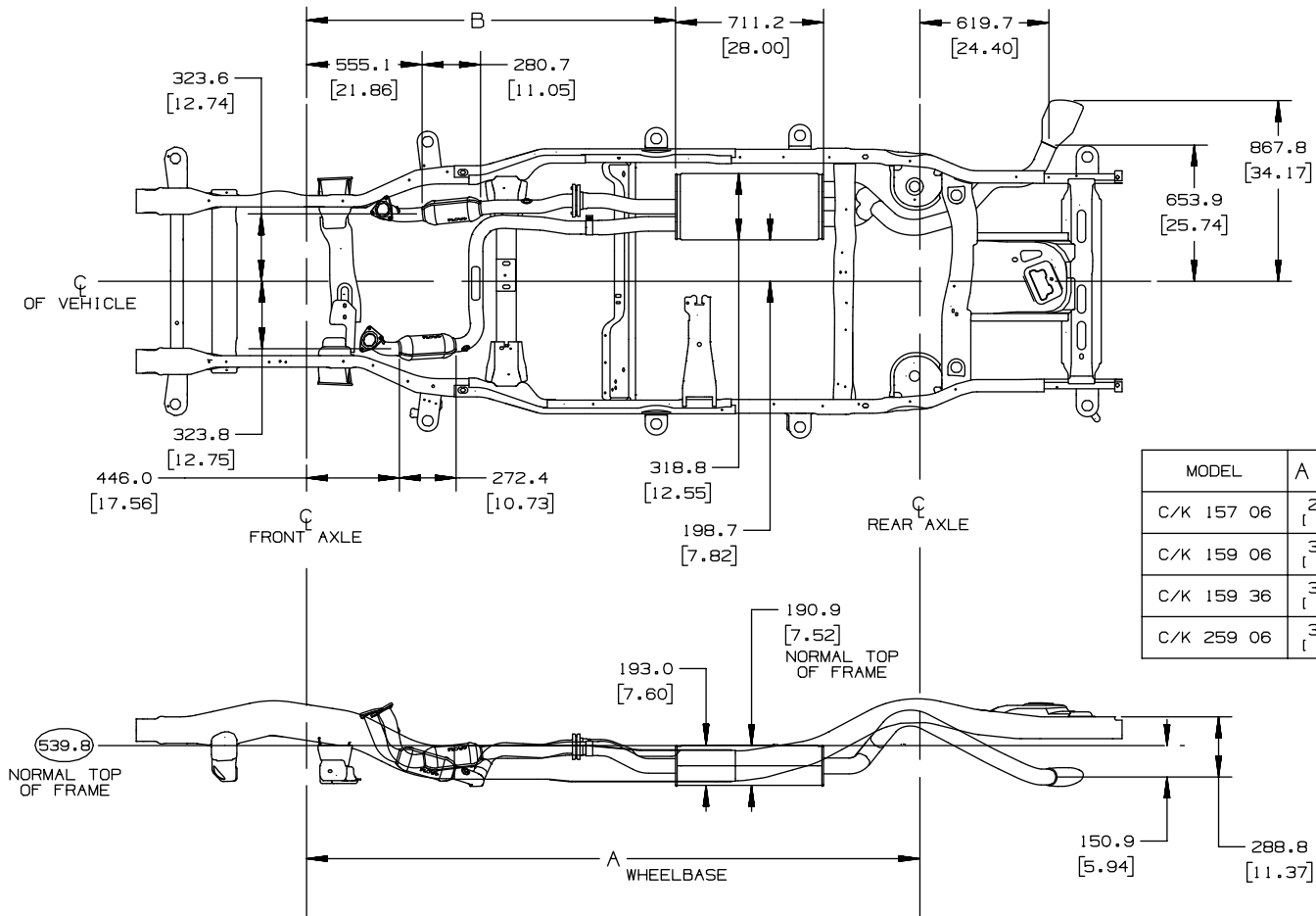

PARTS SHOWN:

FRAME ASM.
CONVERTER ASM.
MUFFLER ASM.

USAGE:

K157 06
K100 0636 & LQ4/LQ9&NC1&Y91
K157 06 & LQ4/LQ9&NC1/NF2&Y91

ENGINE OPTION: LQ4&LQ9 SHOWN

[] = INCHES

1000

8.1 L V8 Gas Engine, Option L18

C 257 43 SHOWN

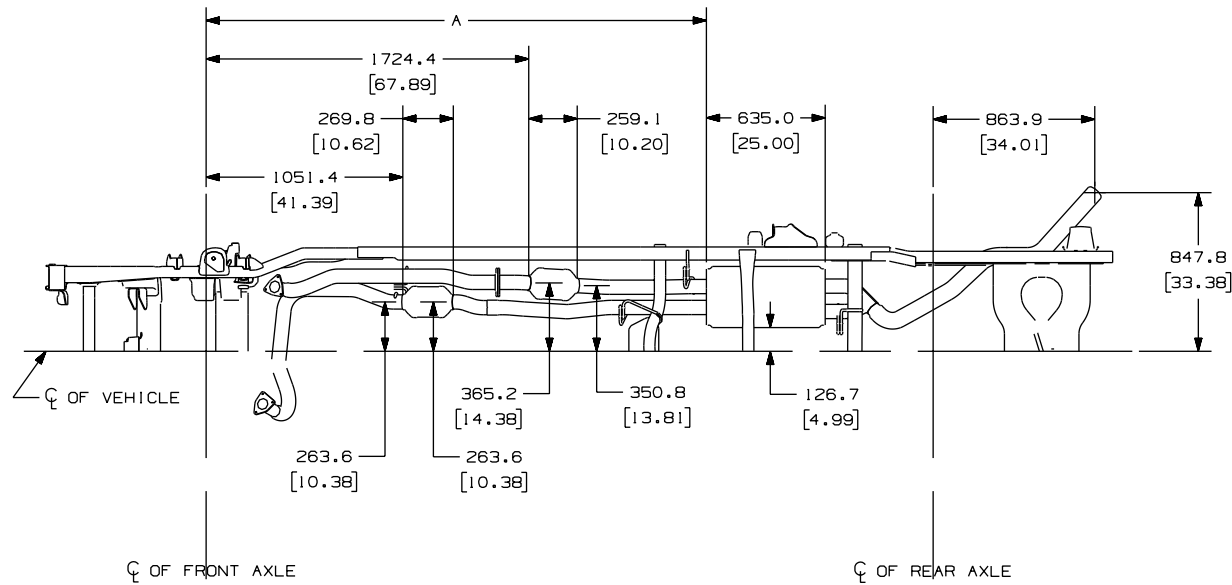

MODEL	A	WHEELBASE
C/K35903 C/K25903HD	2166.1 [85.3]	3378.0 [133.0]
C/K25753HD	2433.1 [95.8]	3645.0 [143.5]
C/K25743HD	2674.1 [105.3]	3886.0 [153.0]
C/K35953 C/K25953HD	2788.1 [109.8]	4000.0 [157.5]
C/K35943 C/K25943HD	3030.1 [119.3]	4242.0 [167.0]

[] = INCHES

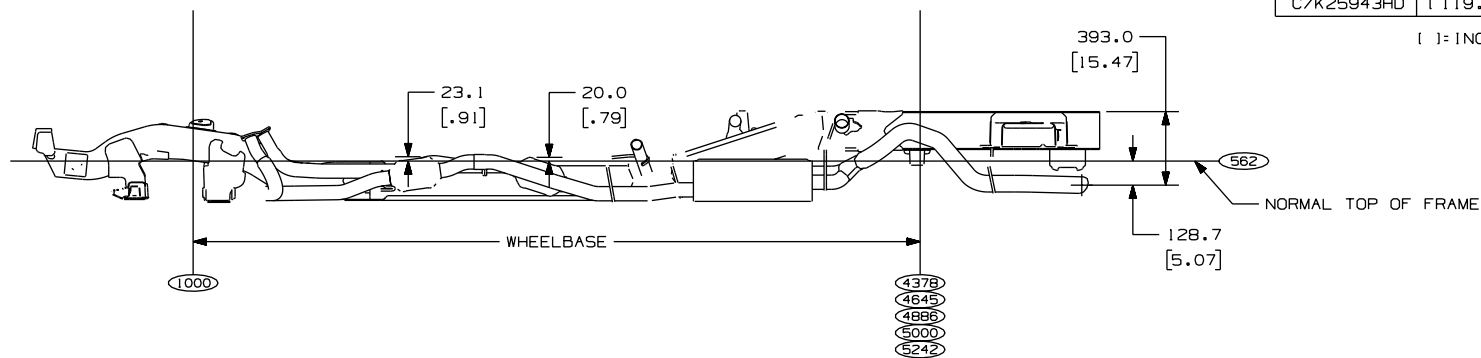

TD005753

C/K 36 (03) 8.1 L V8 Gas Engine, Option L18

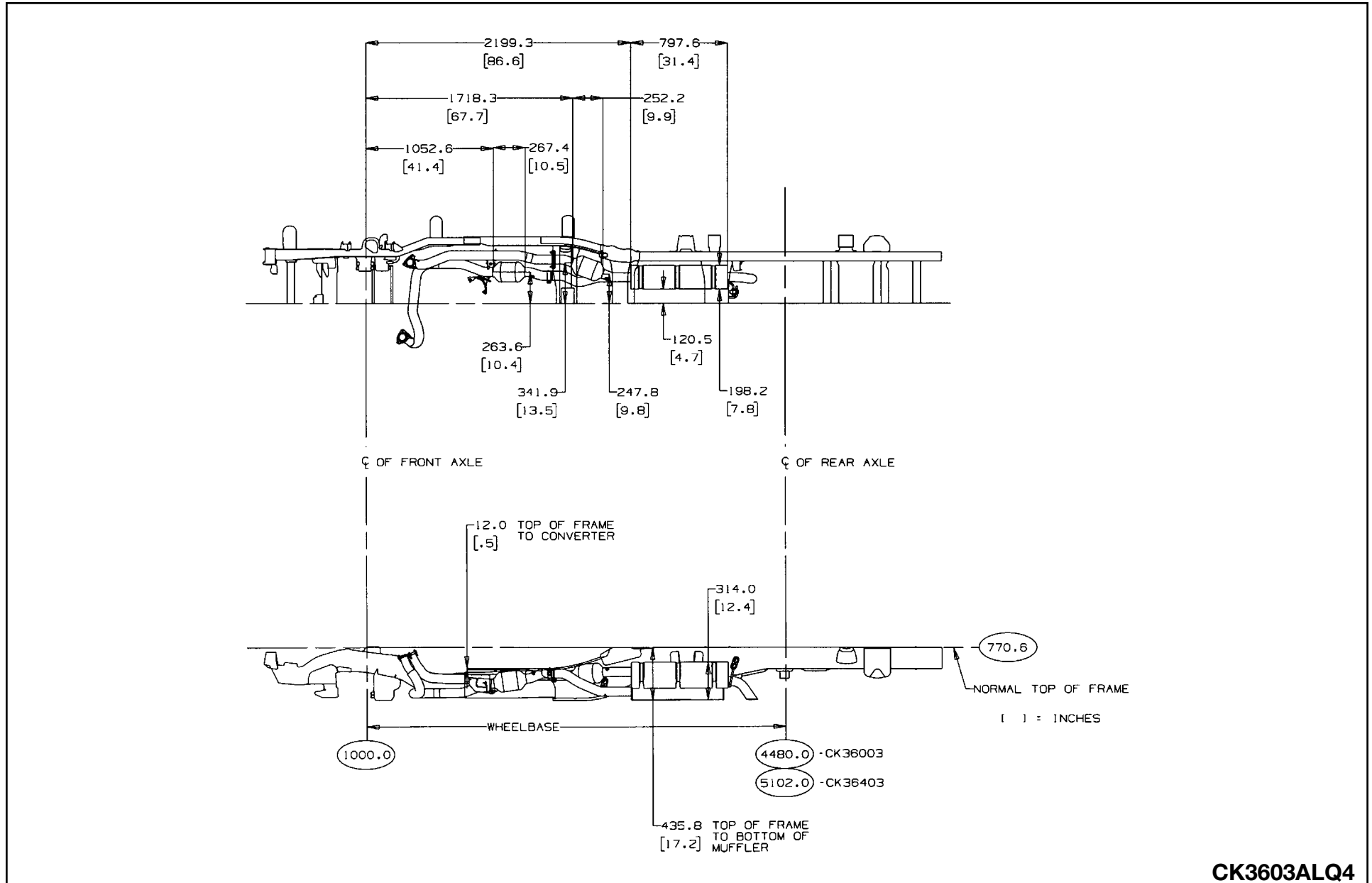

CK3603ALQ4

C/K 36 (53) 8.1 L V8 Gas Engine, Option L18

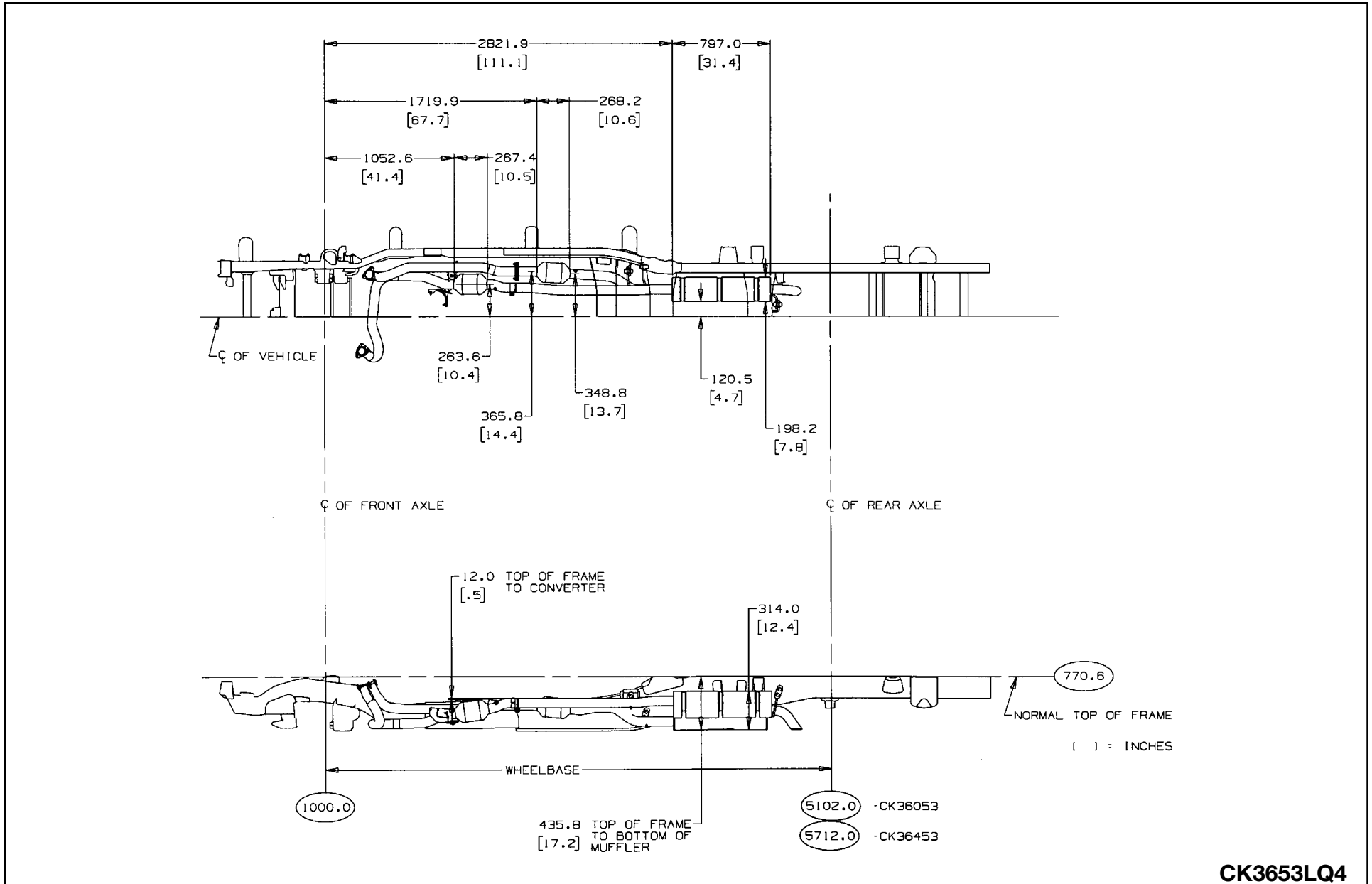

CK3653LQ4

8.1 L V8 Gas Engine, Utility, Option L18 (Federal)

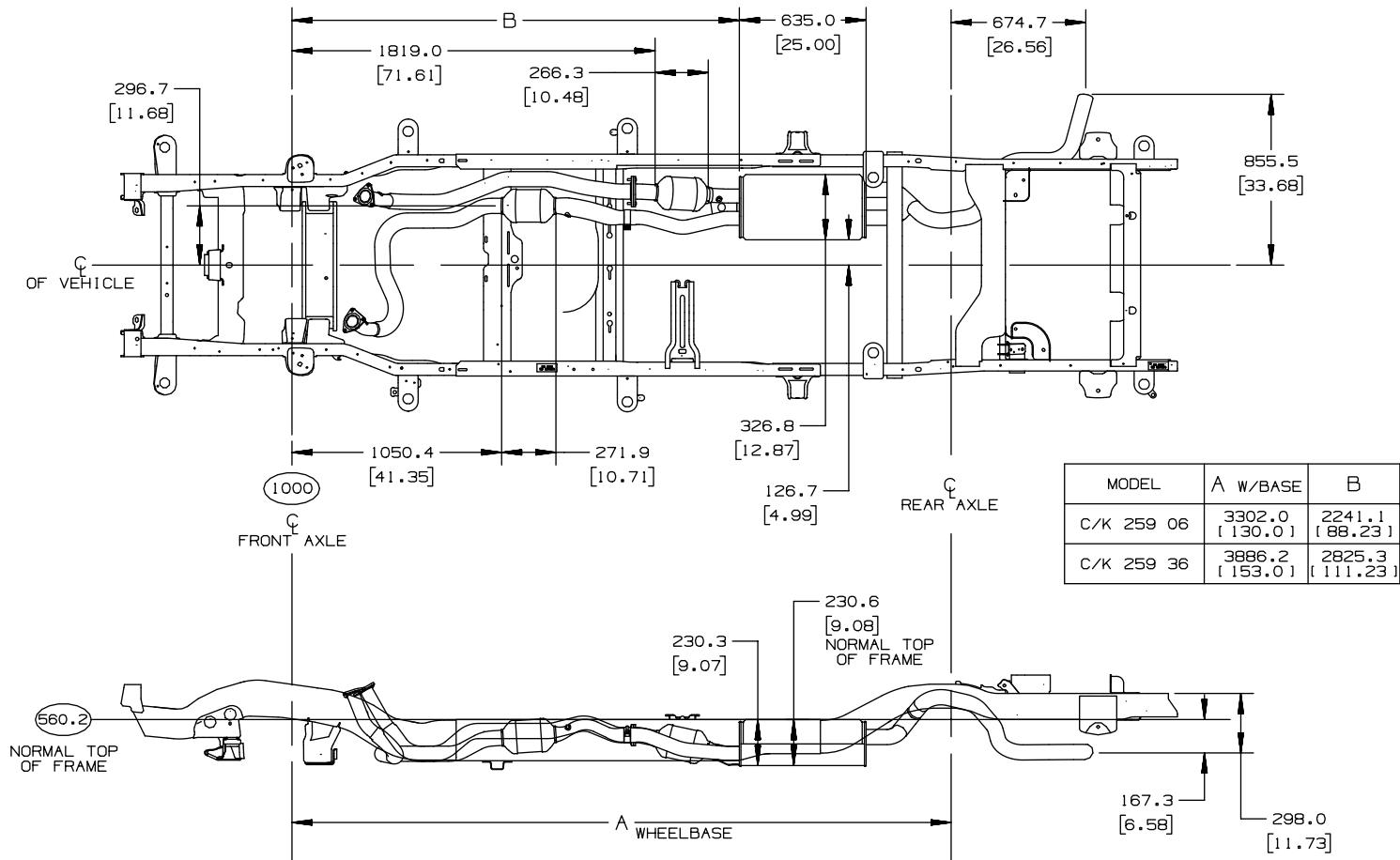

PARTS SHOWN:

FRAME ASM.
CONVERTER ASM.
MUFFLER ASM.

USAGE:

C 259 03
CK200 00 &LQ4/L18&NF2/NF4/NM2-HVY
CK200 0636 &L18&NF2/NF4

ENGINE OPTION: L18 SHOWN

() = INCHES

TD005984h

8.1 L V8 Gas Engine, Utility, Option L18 (California)

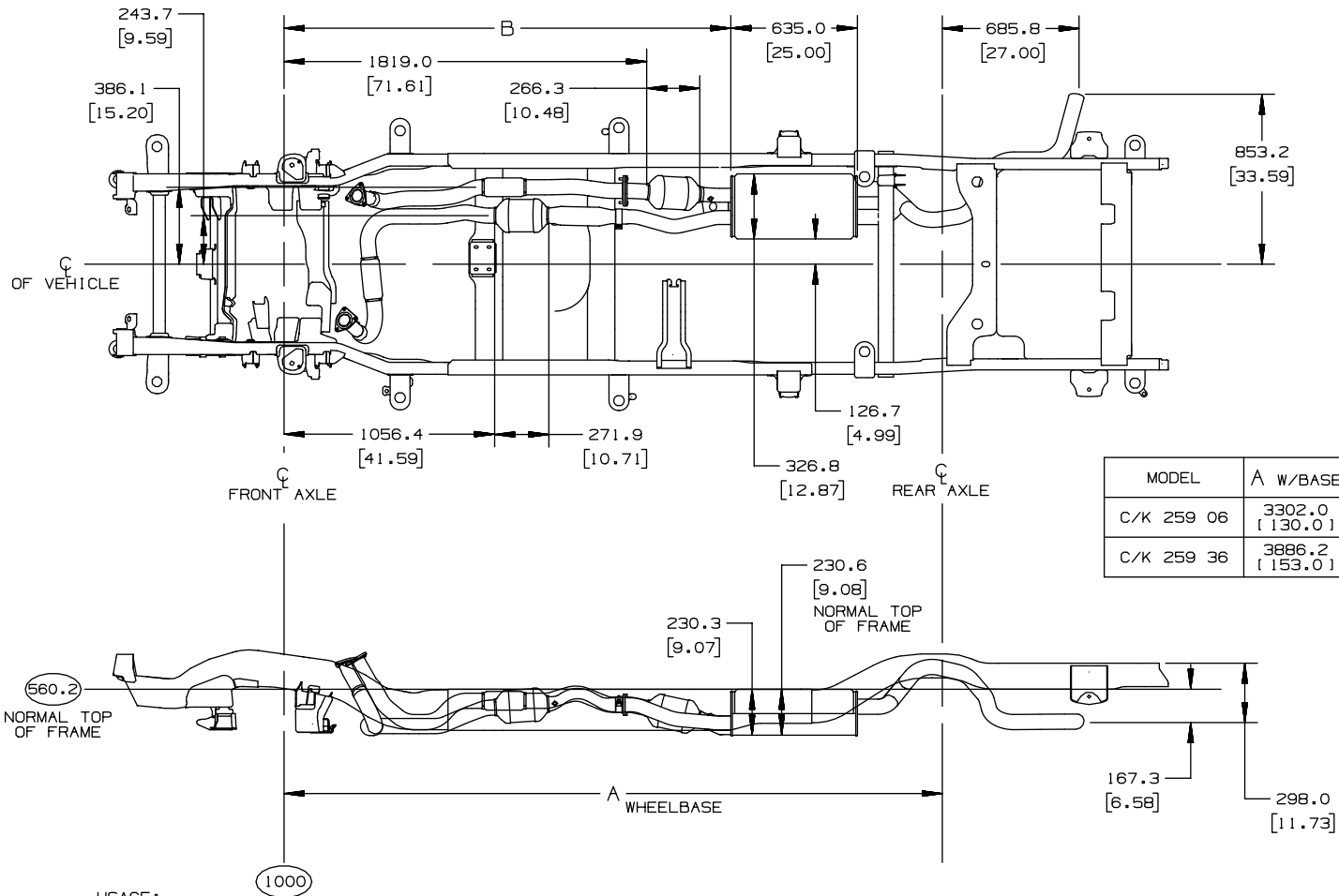

MODEL	A W/BASE	B
C/K 259 06	3302.0 [130.0]	2241.1 [88.23]
C/K 259 36	3886.2 [153.0]	2825.3 [111.23]

PARTS SHOWN:

FRAME ASM.
CONVERTER ASM.
MUFFLER ASM.

USAGE:

C 259 0636 &LQ4/L18&NC1-HVY
CK200 00 &LQ4/L18&NC1
CK200 0636 &LQ4/L18&NC1

ENGINE OPTION: L18 SHOWN

[] = INCHES

8.1 L V8 Gas Engine, Utility, Option L18 (Export)

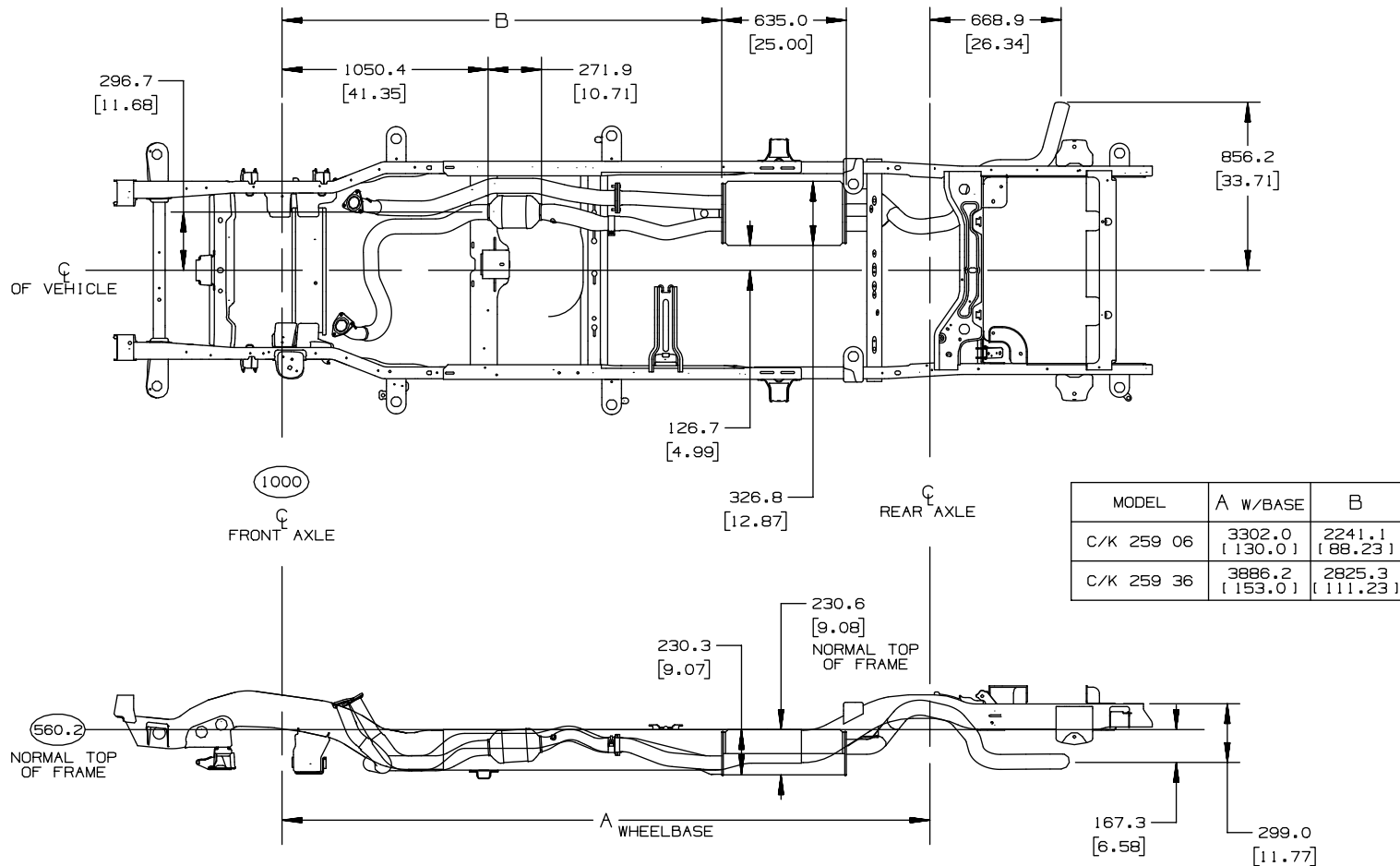

PARTS SHOWN:

FRAME ASM.
CONVERTER ASM.
MUFFLER ASM.

USAGE:

K259 0636
CK200 00 & L04/L18&NF2/NF4/NM2-HVY
CK200 06 & L04/L18&NM2

ENGINE OPTION: L18 SHOWN

() = INCHES

TD005984g

6.6 L V8 Diesel Engine, Pickup, Option LB7

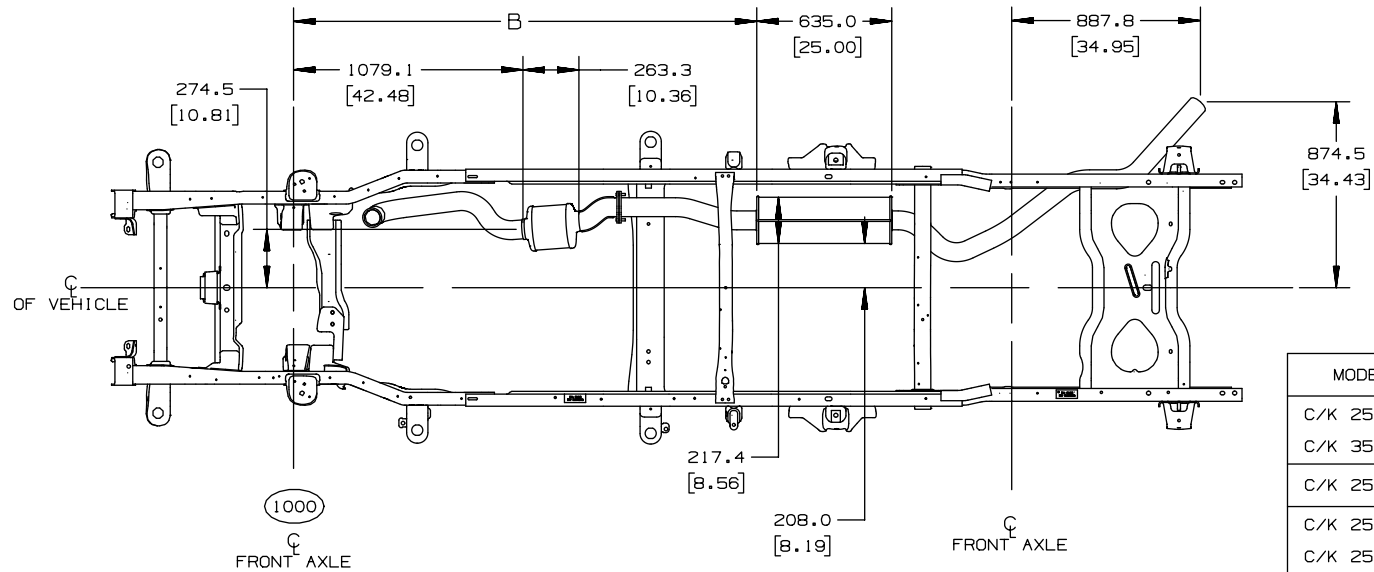

MODEL	A w/BASE	B
C/K 259 03	4378.2 [133.0]	2178.9 [85.8]
C/K 359 03		
C/K 257 53	4645.0 [143.5]	2445.7 [96.3]
C/K 257 43	4886.2 [153.0]	2686.9 [105.8]
C/K 259 43		
C/K 259 53	5000.5 [157.5]	2806.2 [110.5]
C/K 359 53		
C/K 359 43	5241.8 [167.0]	3042.5 [119.8]

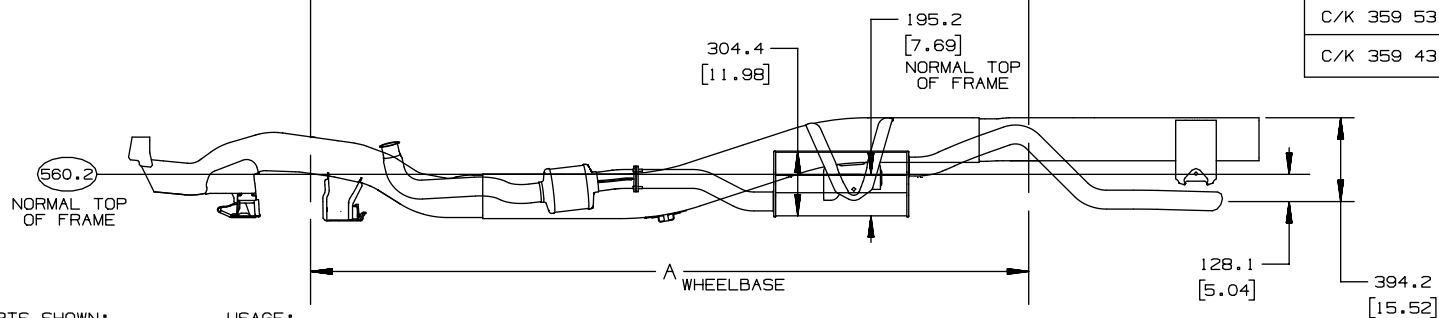

PARTS SHOWN:

FRAME ASM.
CONVERTER ASM.
MUFFLER ASM.

USAGE:

K259359 03
CK200300 00 &LB7&HVY&NC1/NF2
CK259359 03 &LB7&HVY

ENGINE OPTION: LB7 SHOWN

[] = INCHES

6.6 L V8 Diesel Engine, Chassis Cab, Option LB7

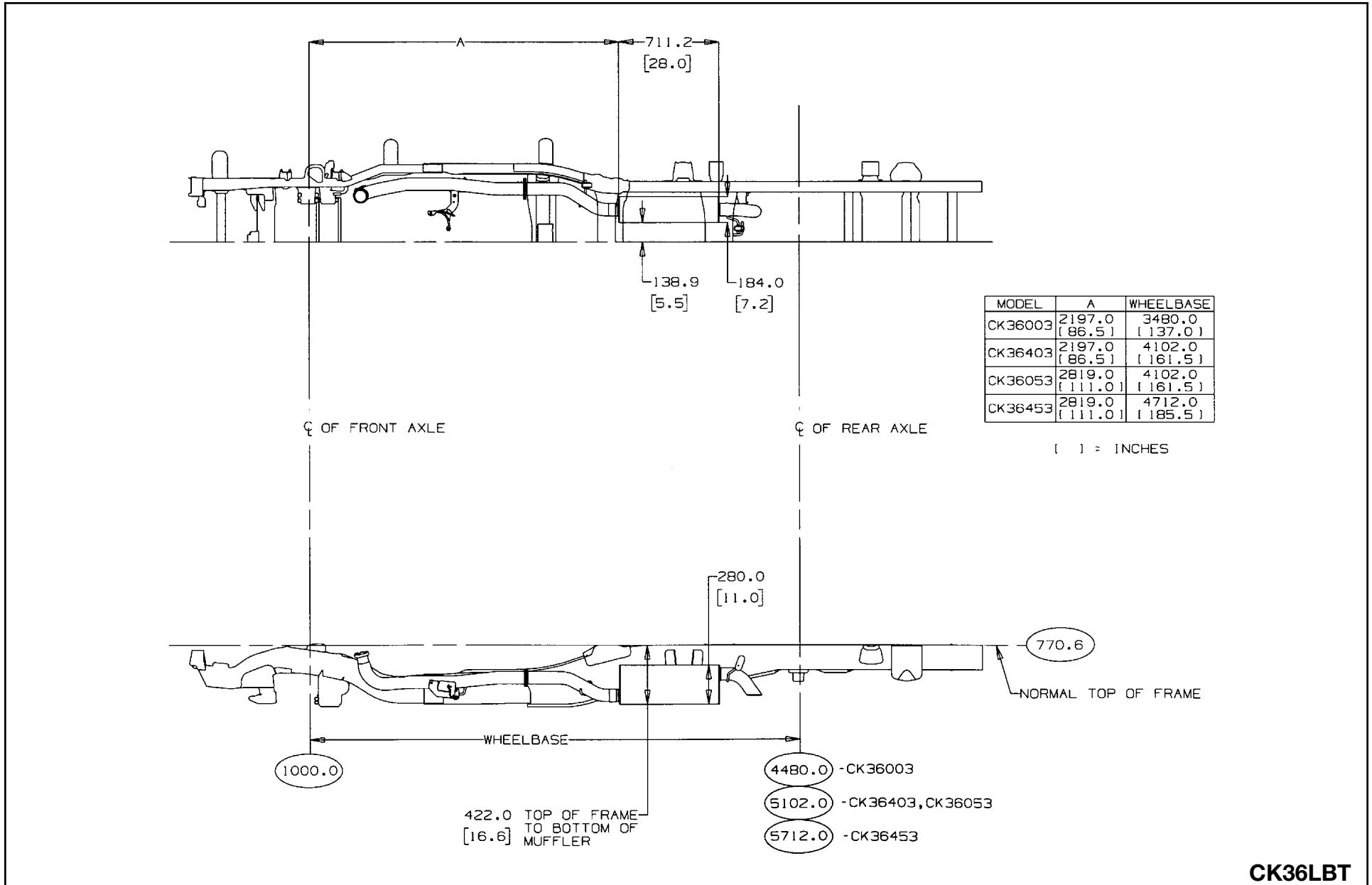

CK36LBT

C/K 36 Power Take Off (Chelsea) 6 Speed Manual Transmission

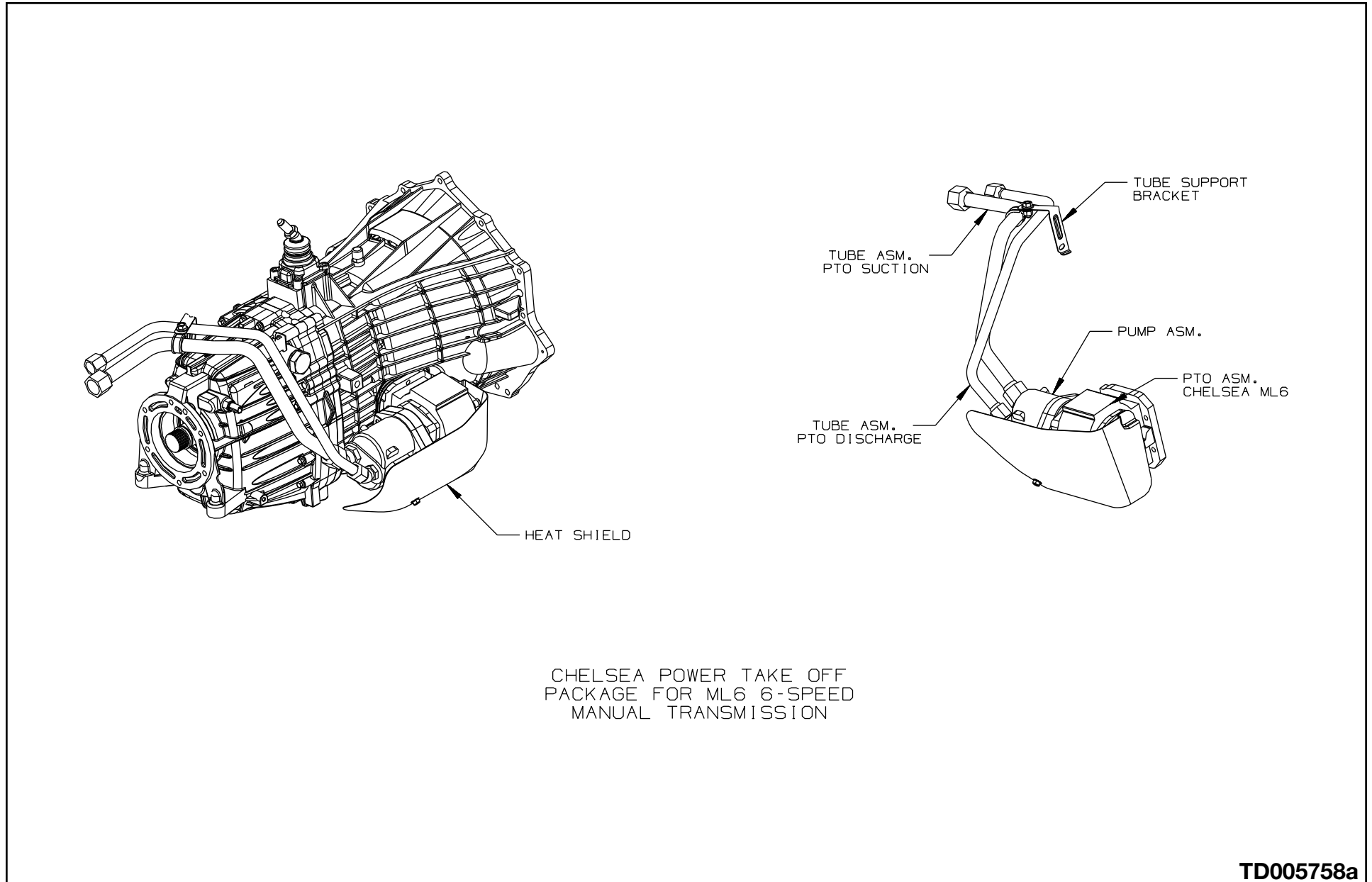

TD005758a

C/K 36 Power Take Off (Muncie) 6 Speed Manual Transmission

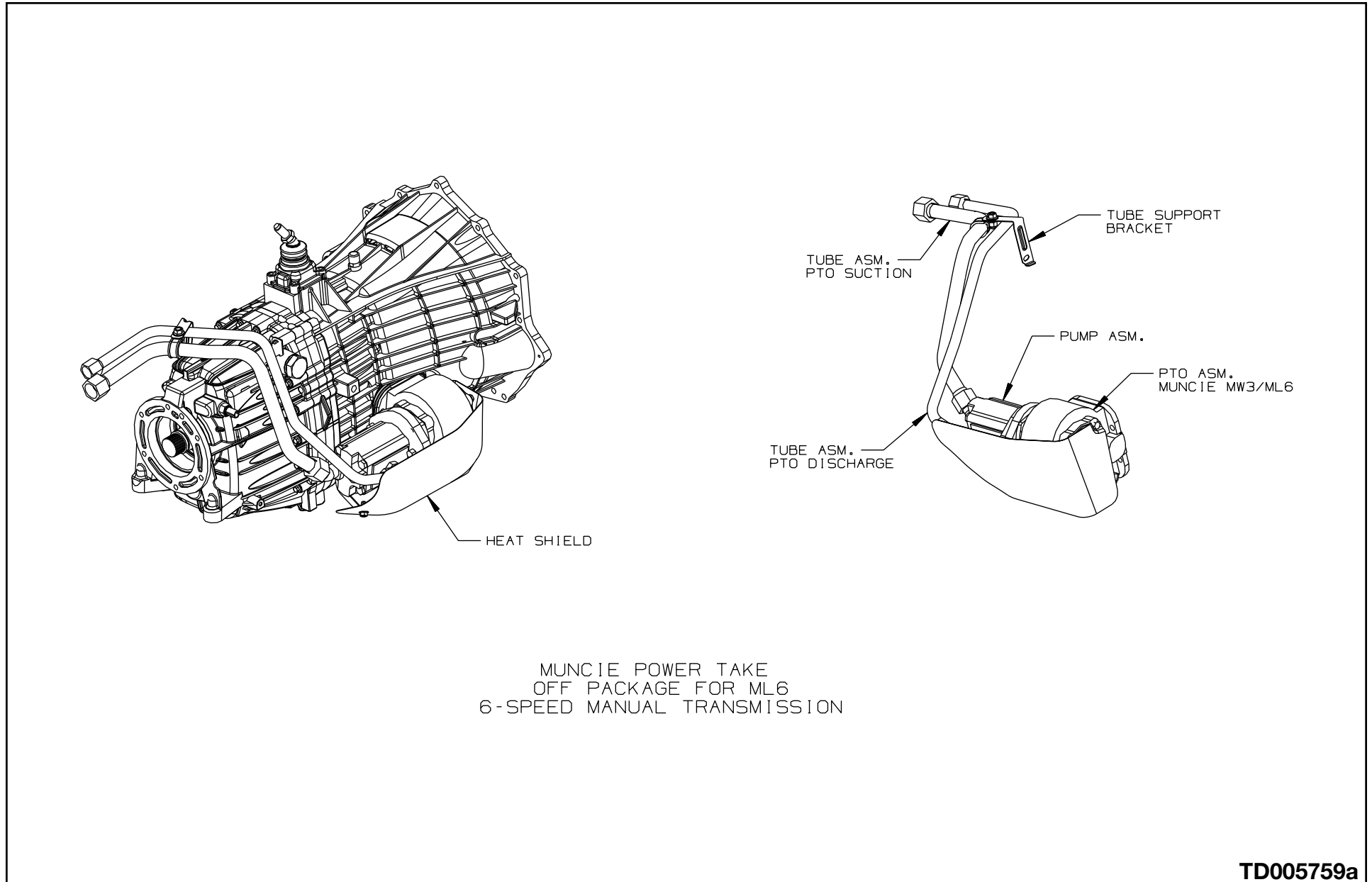

TD005759a

C/K 36 Power Take Off Manual Transmission

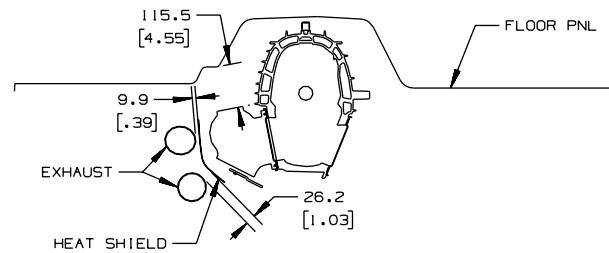
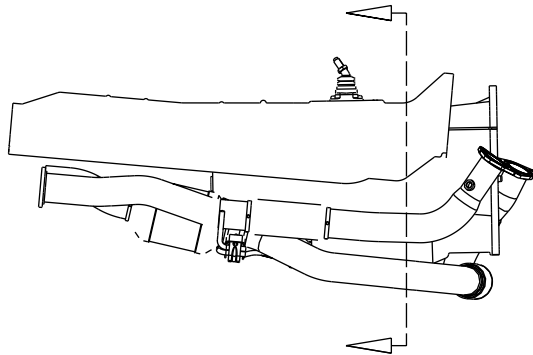

CHELSEA P.T.O. MOUNTED TO
ML6 MANUAL TRANSMISSION

[] = INCHES

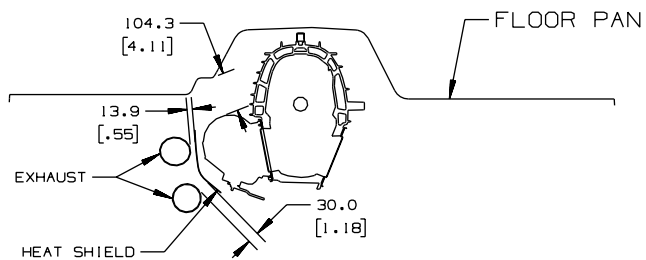
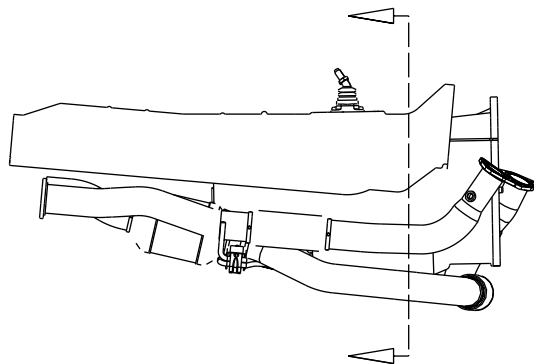

MUNCIE P.T.O. MOUNTED TO
ML6 MANUAL TRANSMISSION

[] = INCHES

TD005758/59B

C/K 36 Power Take Off (Chelsea) 5 Speed Auto Transmission

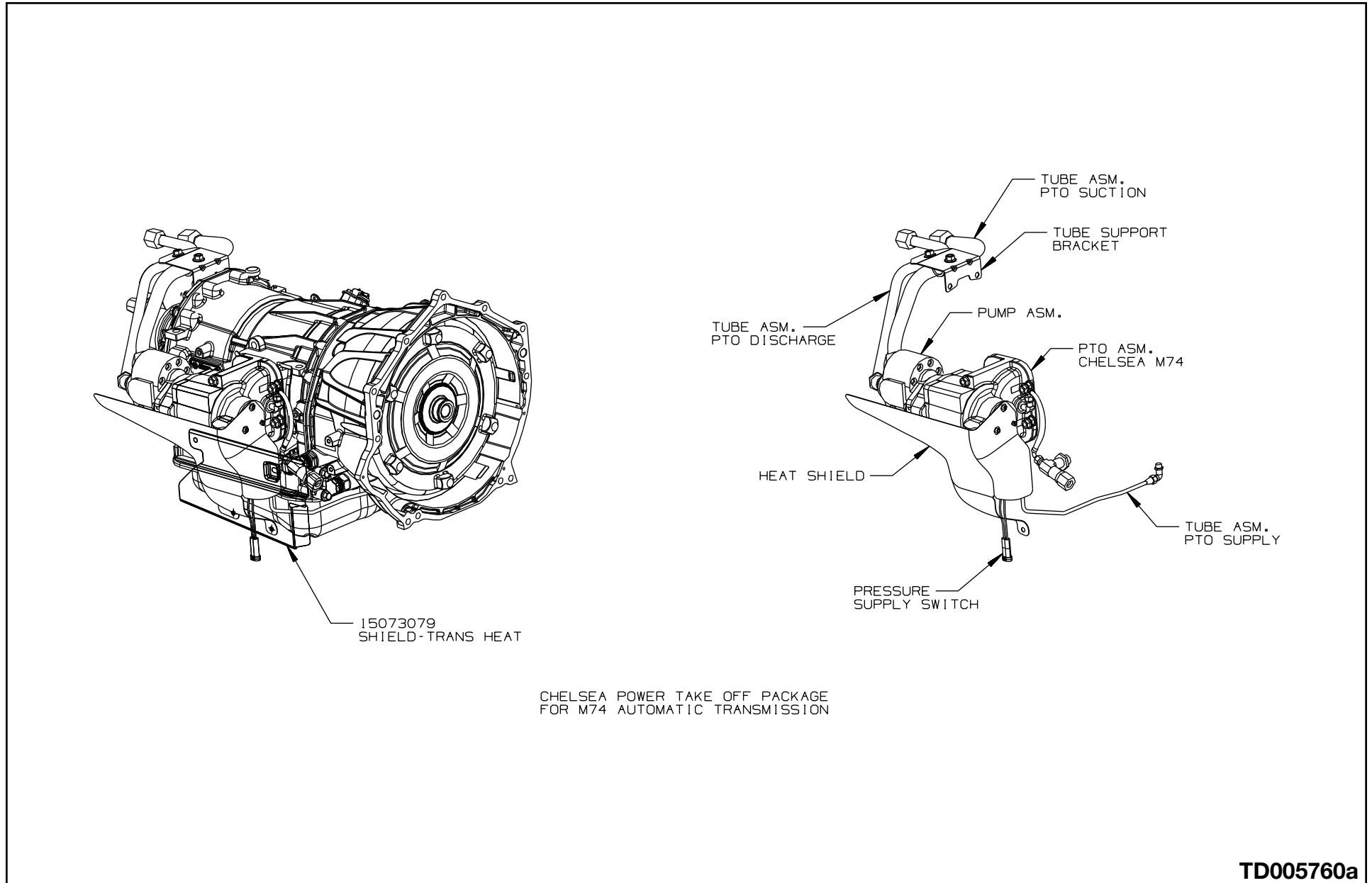

TD005760a

C/K 36 Power Take Off (Muncie) 5 Speed Auto Transmission

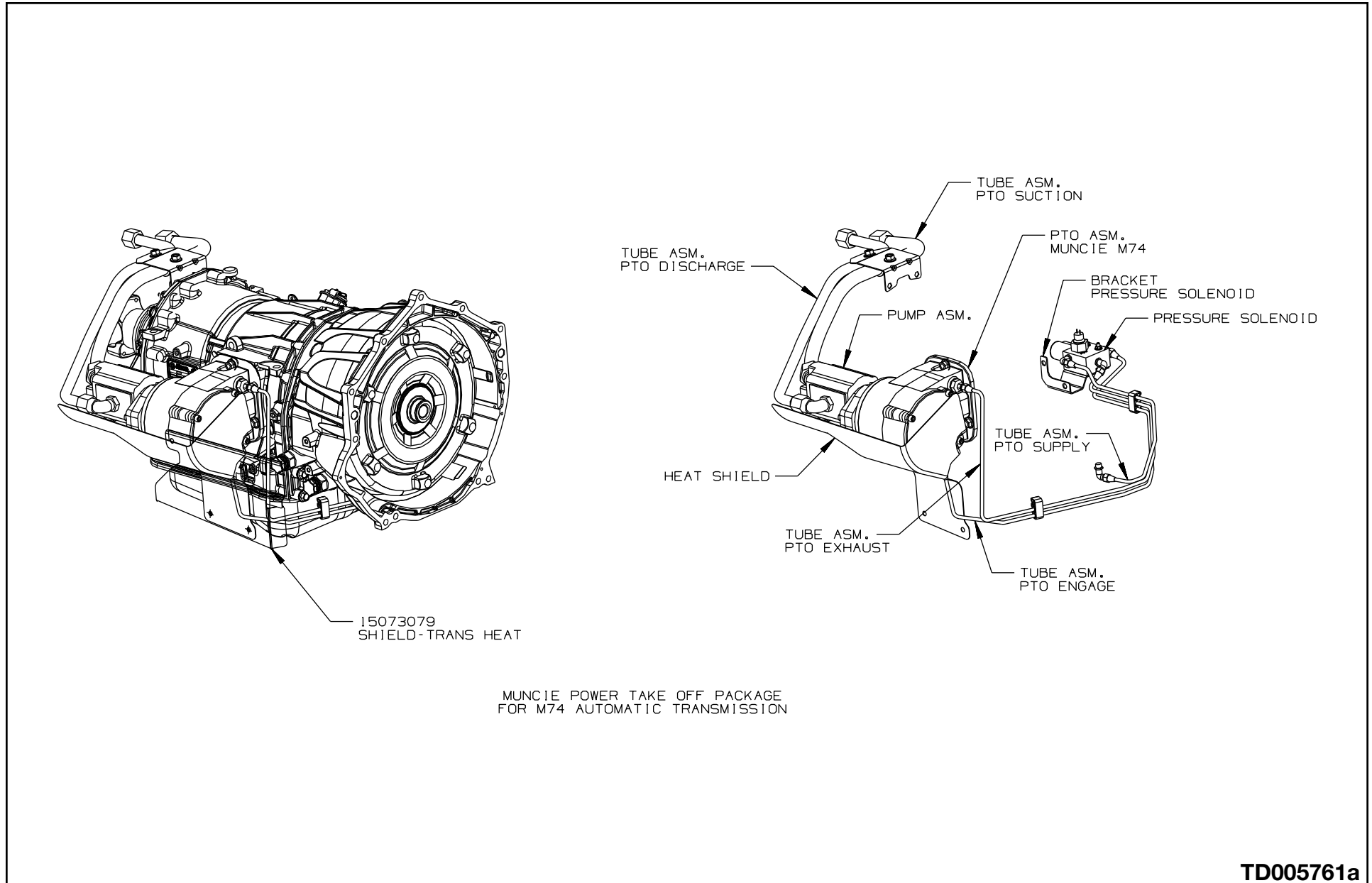

C/K 36 Power Take Off Automatic Transmission

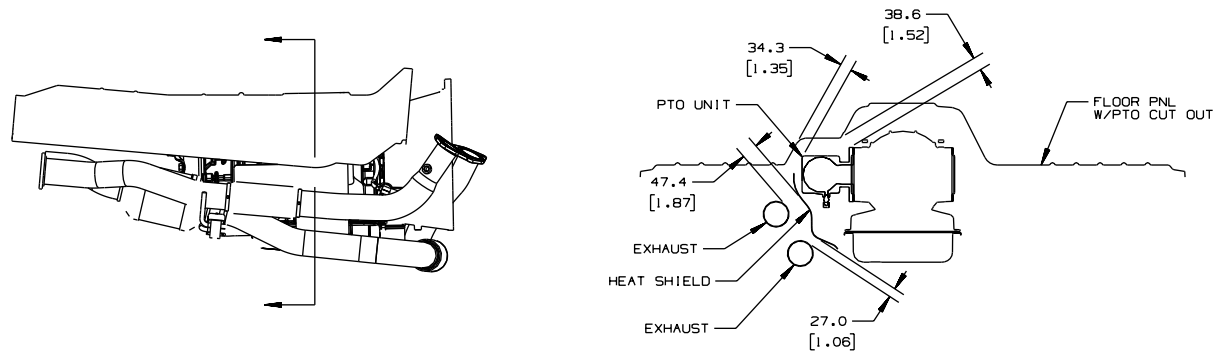

CHELSEA P.T.O. MOUNTED TO M74 AUTOMATIC TRANSMISSION

1" = INCHES

C/K 36 POWER TAKE OFF (CHELSEA) AUTO TRANSMISSION

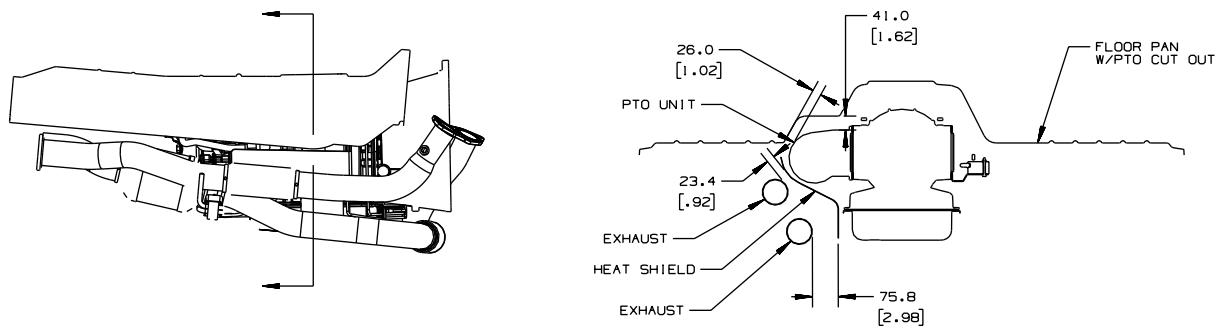

MUNCIE P.T.O. MOUNTED TO M74 AUTOMATIC TRANSMISSION

GMT 800

C/K 36 POWER TAKE OFF (MUNCIE) AUTO TRANSMISSION

Mid Bussed Electrical Center (MBEC)

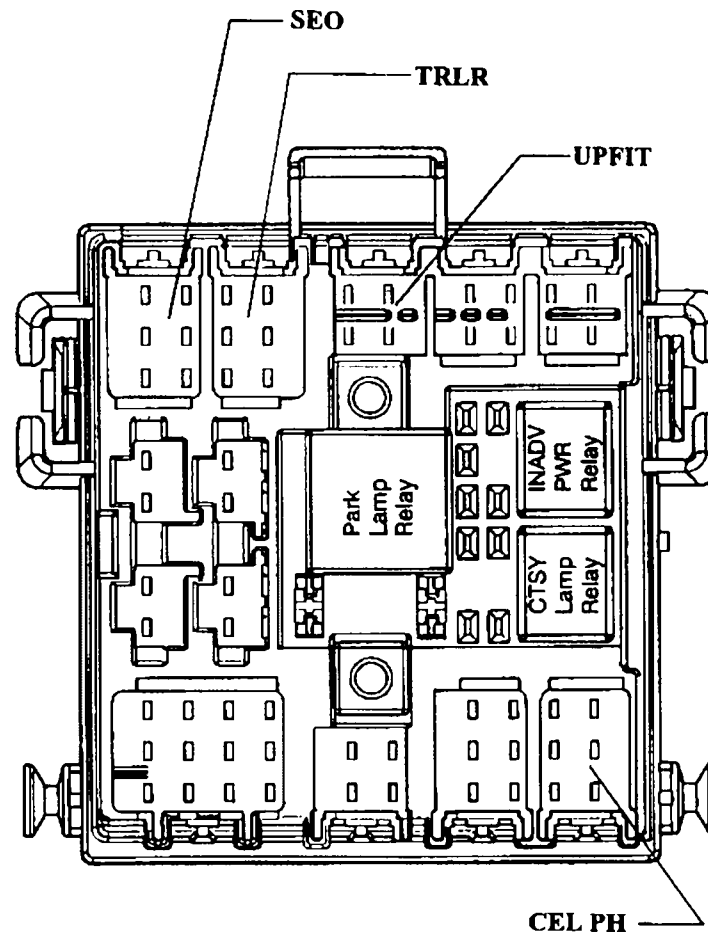

The Mid Bussed Electrical Center (MBEC) is located underneath the instrument panel to the left of the steering column. The MBEC provides access to a number of circuits that upfitters use. These circuits include: Battery, Ground, Ignition, Park Lamp, Speed Signal, etc. The connectors shown above may be used to obtain these feeds provided that they are not used for other purposes (i.e., RPO's, SEO's Trailer Tow, etc.). Please refer to the Circuit Function Charts of these connectors for the circuits, connector part numbers and related information.

MBEC, SEO and Trailer Connector

SEO Connector

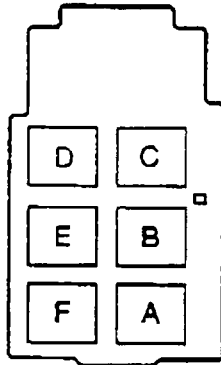

Mating Part: 12193930 Color: Black

<u>Cavity</u>	<u>Wire Color</u>	<u>Circuit No.</u>	<u>Function</u>
A	ORN	2340	Hot at all times
B	---	---	Not used
C	BLK	2550	Ground
D	YEL	243	Hot in Accessory or Run
E	PNK	739	Hot in Run or Start
F	ORN	2240	Hot at all times

TRLR Connector

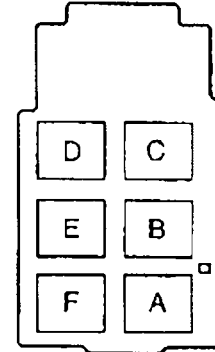

Mating Part: 12193924 Color: Brown

<u>Cavity</u>	<u>Wire Color</u>	<u>Circuit No.</u>	<u>Function</u>
A	BLU LT	1620	Trailer Brake Switch Feed
B	RED	142	Hot at all times ¹⁾
C	BLU DK	47	Trailer Brake Feed ²⁾
D	BRN	2409	Interior Park Lamp Feed
E	---	---	Not used
F	BLK	1850	Ground

MBEC, Upfit and Cell Phone Connector

Upfit Connector

Connector face not available at time of printing

Mating Part: 12194033 Color: Cream

<u>Cavity</u>	<u>Wire Color</u>	<u>Circuit No.</u>	<u>Function</u>
A	WHT	156	Courtesy Lamp Output
B	---	---	Not used
C	DK GRN w/WHT	817	Vehicle Speed Signal
D	ORN	2240	Hot at all times

Cell Phone Connector

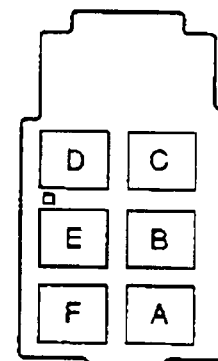

Mating Part: 12193928 Color: Gray

<u>Cavity</u>	<u>Wire Color</u>	<u>Circuit No.</u>	<u>Function</u>
A	ORN	2240	Hot at all times
B	DK GRN	835	Diagnostic Signal (E&C)
C	YEL	243	Hot in Accessory or Run
D	ORN	1044	Serial Data Link
E	PNK	739	Hot in Run or Start
F	BLK	1850	Ground