

Index

OVERVIEW

Body Control System Description and Operation.....	A-1
Power Mode Master	A-1
Serial Data Gateway	A-1
Body Control Module	A-2

DATALINK COMMUNICATIONS DESCRIPTION AND OPERATION

A-3

Circuit Description	A-3
GMLAN High-Speed Circuit Description.....	A-3
Low-Speed Circuit Description	A-4
I/P Splice	A-4
Body Splice	A-5
Serial Data Reference.....	A-5

ELECTRIC POWER MANAGEMENT – DESCRIPTION AND OPERATION

A-6

Electric Power Management	A-6
Power Mode – Description and Operation.....	A-7
Serial Data Power Mode Master	A-7
Relay-Controlled Power Mode.....	A-7
BCM Awake/Sleep Modes	A-8
Retained Accessory Power (RAP) – Description and Operation	A-9
Serial Data Control of Retained Accessory Power (RAP).....	A-9
Relay Control of Retained Accessory Power (RAP).....	A-9

POWER TAKE-OFF (PTO) – BULLETIN #79 (Condensed Version).....

A-10

See this document at: http://www.gmupfitter.com/publicat/bull/52993_UpfitBltn79_D4.pdf

POWER TAKE-OFF (PTO) – BULLETIN #80 (Full Version).....

A-11

See this document at: http://www.gmupfitter.com/publicat/bull/63135_PTO_Bulletin_80_D8.pdf

POWER TAKE-OFF (PTO) – FAST IDLE (UF3) OVERVIEW – BULLETIN #82.....

A-12

See this document at: http://www.gmupfitter.com/publicat/bull/63135_FastIdle_UI_82_D3.pdf

ELECTRICAL MANUAL – 2009 LIGHT DUTY FULL SIZE C/K TRUCKS

SNOWPLOW/FRONT LIGHTING – PREP (VYU) ELECTRICAL PROVISIONS	A-13
Index	A-13
Emergency Roof-Mounted Lamp Switch.....	A-14
VYU Generators.....	A-14
Accessory Harness Grommet	A-14
Forward Lamp Harness In-Line Connectors.....	A-14
Backup Lamp Power Feed.....	A-14
Roof-Mounted Beacon (TRW) – Installation Instructions.....	A-15
Restoring Power.....	A-17
Harness Assembly and Mounting	A-18
Wiring Schematic	A-19
Maintenance	A-19
GENERATOR USAGE	A-20
ACCESSORY HARNESS GROMMET	A-21
VYU HOLE LOCATION	A-22
FORWARD LIGHTING & ADD'L TURN SIGNALS – CHEVROLET SUVs (X88) – FRONT OF VEHICLE	A-23
Forward Lighting & Additional Turn Signals – Chevrolet Tahoe & Suburban (X88) Overview	A-24
Front Fascia Harnesses – Chevrolet Tahoe (X88)	A-25
X100 Forward Lamp Harness to Left Headlamp Harness (X88-Z75)	A-26
X106 Forward Lamp Harness to Right Headlamp Harness (X88 or Z75)	A-27
HEADLAMP REPLACEMENT – CHEVROLET TAHOE SUV (X88)	A-28
HEADLAMP BULB REPLACEMENT – CHEVROLET TAHOE SUV (X88)	A-29
FORWARD LIGHTING & ADD'L TURN SIGNALS – GMC YUKON (Z88) – FRONT OF VEHICLE	A-30
Forward Lighting & Additional Turn Signals – GMC Yukon (Z88) Overview	A-31
Front Fascia Harnesses – GMC Yukon (Z88).....	A-32
X104 Forward Lamp Harness To Right Front Headlamp Harness (Z88).....	A-33
X107 Forward Lamp Harness to Forward Lamp Harness (VYU).....	A-34
X108 Forward Lamp Harness to Forward Lamp Harness (VYU).....	A-35

ELECTRICAL MANUAL – 2009 LIGHT DUTY FULL SIZE C/K TRUCKS

HEADLAMP REPLACEMENT – GMC YUKON SUV (Z88)	A-36
HEADLAMP BULB REPLACEMENT – GMC YUKON SUV (Z88)	A-37
FRONT LIGHTS	
Chevrolet Silverado Pickup (X88)	A-38
GMC Sierra Pickup (Z88).....	A-39
Forward Lighting & Additional Turn Signals	
Chevrolet Silverado/GMC Sierra Pickups Overview	A-40
Forward Lamp Harness – Diesel – Chevy Silverado/GMC Sierra Pickups	A-41
X100 to Left Headlamp Harness.....	A-42
X106 to Right Headlamp Harness.....	A-43
HEADLAMP REPLACEMENT – CHEVROLET SILVERADO/GMC SIERRA PICKUPS	A-44
HEADLAMP BULB REPLACEMENT – GMC YUKON SUV (Z88)	A-45
REPLACEMENT BULBS	
2008 Chevrolet Silverado	A-46
2008 Chevrolet Tahoe.....	A-46
2008 GMC Yukon	A-46
TRAILER WIRING	
Lighting Schematic	A-47
Connector.....	A-48
Connector (UY7) Location	A-49
TRAILER/CAMPER WIRING	
Connector – Wiring Schematic (1 of 2)	A-50
Connector – Wiring Schematic (2 of 2)	A-51
Wiring Location.....	A-52
Electric Brake Controller Wiring	A-53
Wiring Schematic.....	A-56
Installing Auxiliary 12-Volt Feed to Trailer	A-57
Trailer Brake Controls – Description and Operation – Option JL1	A-58

TRAILER BRAKE CONTROLLER

Switch Location	A-61
Module (TCBM) Location.....	A-62

AUTOMATIC TRANSMISSION SHIFT LOCK CONTROL

A-63

CRUISE CONTROL AND/OR PTO INOPERATIVE

A-64

DIESEL PARTICULATE FILTER

A-65

12-VOLT POWER SUPPLY (SEO 9L4)

Electrical Connections	A-67
Installation Instructions.....	A-67

LED OR ADDITIONAL TURN SIGNALS – SUVs.....

A-68

GMC Yukon (Z88) Overview	A-69
Chevrolet Tahoe and Suburban (X88) Overview	A-70

LED AND/OR ADDITIONAL TURN SIGNALS – CHEVROLET AND GMC PICKUPS

A-71

SERVICE BODY REAR LIGHTING OPTIONS (Including LED)

A-72

See this document at: http://www.gmupfitter.com/publicat/bull/63135_Bulletin_81_D3.pdf

SERVICE BODY REAR LIGHTING OPTIONS – PICKUP BOX DELETE (ZW9).....

A-73

POWER DISTRIBUTION: PICKUP

Preface: Support Information	B-1
------------------------------------	-----

FUSE BLOCK UNDERHOOD

View – Label.....	B-5
Top View – Diesel	B-6
Top View – Gas.....	B-7
Bottom View.....	B-8

UNDERHOOD DEVICE USAGE

Diesel	B-9
Gas.....	B-12

JUNCTION BLOCK

Left I/P – Fuse Block Location View	B-16
Left I/P – Top View	B-17
Left I/P - Connector X1.....	B-18
Left I/P - Connector X1 & X2.....	B-20
Left I/P - Connector X2 & X3.....	B-21
Left I/P - Connector X4 & X5 (SPO Alarm).....	B-22
Left I/P - Connector X7 (JF4) & X8.....	B-23
Left I/P - Connector X9 & X10.....	B-24
Left I/P - Connector X11 & X12.....	B-25
Left I/P - Connector X13 & X14.....	B-26
Right I/P - Fuse Block Location View.....	B-27
Right I/P - Connector X1	B-28
Right I/P - Connector X2	B-31
Right I/P - Connector X3	B-32
Right I/P - Connector X4	B-33
Right I/P - Connector X5 & X6	B-34
Rear Lamps - Connector X1.....	B-35
Rear Lamps - Connector X2 & X3.....	B-36
Rear Lamps - Connector X4.....	B-37

GROUND DISTRIBUTION

Diesel - 2007 Chevrolet Silverado - 4WD	B-38
G107, G108, F110, G111, and G104	B-40
G301, G302, G303, and G304	B-41
G305	B-42

ELECTRICAL COMPONENT LOCATIONS LIST

B-43

ENGINE CONTROL MODULE (ECM)

LU3 - 4.3L Gas - Connector X-1	C-1
LU3 - 4.3L Gas - Connector X-2	C-3
LU3 - 4.3L Gas - Location	C-5
4.8L, 5.3L & 6.0L Gas - Connector X-1	C-6
4.8L, 5.3L & 6.0L Gas - Connector X-2	C-8
4.8L, 5.3L & 6.0L Gas - Location	C-10
LMM 6.6L Diesel - Connector X-1	C-11
LMM 6.6L Diesel - Connector X-2	C-14
LMM 6.6L Diesel - Location	C-16

ENGINE HARNESS TO PTO JUMPER HARNESS (PTO)

X124	C-17
X124 - PTO Connector Location	C-18

REAR LIGHTING - UTILITY

C411 Chassis Harness To Left Rear Lamp Harness (Except E52/Z75)	C-19
C411 Chassis Harness To Left Rear Lamp Harness (E52 Except Z75)	C-20
C411 Chassis Harness To Left Rear Lamp Harness (Z75)	C-21
C412 Chassis Harness To Right Rear Lamp Harness (Except E52/Z75)	C-22
C412 Chassis Harness To Right Rear Lamp Harness (E52 Except Z75)	C-23
C412 Chassis Harness To Right Rear Lamp Harness (Z75)	C-24
C411 & C412 Location - Short Wheel Base	C-25
C411 & C412 Location - Long Wheel Base	C-26
Rear Of The Vehicle (X88 w/E52)	C-27
Rear Of The Vehicle (X88 Except E52)	C-28

REAR LIGHTING - PICKUP & CHASSIS CAB

Junction Block C-1 - Rear Chassis Harness Connector	C-29
Junction Block C-2 - Left Tail Lamp Connector	C-30
Junction Block C-3 - License Plate Connector	C-31
Junction Block C-4 - Right Tail Lamp Connector	C-32
Junction Block Location	C-33
Rear Of The Vehicle - Tail Lamp (X88).....	C-34
Rear Of The Vehicle - Tail Lamp (Z88).....	C-35
Trailer Connector	C-36
Trailer Connector Location	C-37

SPECIAL APPLICATIONS

Tail Lamp Wiring for Pickup Box Removal.....	E-1
Rear Junction Block/Bracket Installation - Chassis Cab and Box Delete (ZW9) Trucks	E-2
Tail Lamps/Rear Junction Block - Chassis Cab and Box Delete (ZW9) Trucks.....	E-3
Schematics - Rear Lamps - Chassis Cab and Box Delete (ZW9) Trucks.....	E-5
Schematics - Trailer - Chassis Cab and Box Delete (ZW9) Trucks.....	E-7
Junction Block Connector X1 - Chassis Cab and Box Delete (ZW9) Trucks.....	E-8
Junction Block Connector X2 & X3 - Chassis Cab and Box Delete (ZW9) Trucks.....	E-9
Junction Block Connector X4 - Chassis Cab and Box Delete (ZW9) Trucks.....	E-10
Installation of Aftermarket Accessories - Battery, Ignition and Ground Feeds.....	E-11

Overview

BODY CONTROL SYSTEM DESCRIPTION AND OPERATION

The body control system consists of the Body Control Module (BCM), communications, and various input and outputs. Some inputs, outputs and messages require other modules to interact with the BCM. The BCM also has discrete input and output terminals to control the vehicle's body functions. The BCM is wired to the GMLAN high speed serial data buss and the GMLAN low speed serial data buss and acts as a gateway between them. If the BCM does not communicate the vehicle will not start due to the inability of the Engine Control Module (ECM)/ Powertrain Control Module (PCM) and Theft Deterrent Module (TDM) to communicate without the BCM providing the gateway function.

POWER MODE MASTER

This vehicles BCM functions as the Power Mode Master (PMM). The ignition switch is a low current switch with multiple discrete ignition switch signals to the PMM for determination the power mode that will be sent over the serial data circuits to the other modules that need this information, and so the PMM will activate relays and other direct outputs of the PMM as needed.

SERIAL DATA GATEWAY

The BCM in this vehicle functions as a gateway or translator. The purpose of the gateway is to translate serial data messages between the GMLAN high speed buss and the GMLAN low speed buss for communication between the various modules. The gateway will interact with each network according to that network's transmission protocol.

One example of this necessary communication is the communication between the ECM/PCM which is high speed serial data and TDM which is low speed serial data. If these modules can not exchange information, the vehicle will not start.

Communication between the BCM and a scan tool can be on the high speed GMLAN network or low speed GMLAN network. If one network is lost, the BCM can still communicate with the scan tool. A lost communication Diagnostic Trouble Code (DTC) typically is set in modules other than the module with a communication failure.

Overview (cont'd)

BODY CONTROL MODULE

The various body control module (BCM) input and output circuits are described in the corresponding functional areas indicated on the BCM electrical schematics. Some BCM functions with the subsystems may be as a gateway only or as an enable for the system. The BCM related systems/subsystems include, but are not limited to the following:

- Antilock Brake System (ABS)
- Automatic Day-Night Mirror
- Cruise Control System
- Electric Power Management (EPM)
- Exterior Lighting--Refer to
- Horn System
- HVAC
- Instrument Cluster Indicator Control
- Interior Lighting
- Power Door Lock System
- Rear Window Defogger System
- Redundant Steering Wheel Controls
- Remote Function Actuation (RFA) Control
- Retained Accessory Power (RAP)
- Shift Lock Control System
- Starting System
- Supplemental Inflatable Restraint (SIR) System
- Theft Deterrent
- Tire Pressure Monitor (TPM) System
- Wiper/Washer System Functions

DataLink Communications Description and Operation

CIRCUIT DESCRIPTION

The communication among control modules is performed through the high speed GMLAN serial data circuits and the low speed GMLAN serial data circuit. The modules that need real time communication are attached to the High Speed GMLAN network. The Body Control Module (BCM) is the gateway between the high and low speed networks. Refer to **Body Control System Description and Operation** for more information about the gateway.

Signal supervision is the process of determining whether an expected signal is being received or not. Some messages are sent on a periodic basis and are interpreted as a heartbeat of a device. If such a signal is lost, the signal supervision part of the software will set a no communication DTC (U. code) against the missing device. This code is mapped on the Tech 2 screen as a code against the physical device. A lost communication DTC typically is set in modules other than the module with a communication failure.

GMLAN HIGH-SPEED CIRCUIT DESCRIPTION

The Data Link Connector (DLC) allows a scan tool to communicate with the high speed GMLAN serial data circuit. The serial data is transmitted on 2 twisted wires that allow speed up to 500 Kb/s. The twisted pair is terminated with two 120-ohm resistors, one is internal to the Engine Control Module (ECM) and the other is after the Electronic Brake Control Module (EBCM), or if equipped, the suspension control module. The high speed GMLAN is a differential bus. The high speed GMLAN serial data bus (+) and high speed GMLAN serial data (-) are driven to opposite extremes from a rest or idle level. The idle level, which is approximately 2.5 volts, is considered recessive transmitted data and is interpreted as a logic 1. Driving the lines to their extremes, adds 1 volt to the high speed GMLAN serial data bus (+) and subtracts 1 volt from the high speed GMLAN serial data bus (-) wire. If a communication signal is lost, the application will set a no communication code against the respective control module. This code is mapped on the Tech 2 screen as a code against the physical device. Note: a loss of serial data DTC does not represent a failure of the module that the code is set in. The high speed GMLAN serial data allows communication between the BCM, ECM, Transmission Control Module (TCM), Vehicle Communication Interface Module (VCIM), 4WD control module, EBCM, and the suspension control module depending on RPO.

DataLink Communications Description and Operation (cont'd)

GMLAN LOW-SPEED CIRCUIT DESCRIPTION

The Data Link Connector (DLC) allows a scan tool to communicate with the low speed GMLAN serial data circuit. The serial data is transmitted over a single wire to the appropriate control modules. Under normal vehicle operating conditions, the speed of the buss is 33.33 Kb/s. This protocol produces a simple pulse train sent out over the GMLAN low speed serial data bus. When a module pulls the buss high, 5 volts, this creates a logic state of 0 on the buss. When the buss is pulled low, 0 volts, it is translated as a logic state of 1. To wake the control modules connected to the GMLAN low speed serial data buss, a wake up signal is sent out over the buss. Modules connected to the GMLAN low speed serial data buss can be part of a virtual network as described in GMLAN High Speed Circuit Description above. The modules on the GMLAN low speed serial data buss are connected to the buss using several splice or "star" connectors separating groups of modules. The following list states the splices and modules connected to the low speed serial data circuits:

I/P Splice

- Data Link Connector (DLC), connected only to the Instrument Panel (I/P) splice.
- Amplifier (Amp)
- Rear Seat Audio (RSA) .
- Vehicle Communication Interface Module (VCIM)
- Digital Radio Receiver (DRR)
- Inside Rearview Mirror Module (ISRVM), connected through the mid I/P fuse block
- Instrument Panel Cluster (IPC)
- Body Control Module (BCM)
- Theft Deterrent Module (TDM)
- Heater Ventilation and Air Conditioning (HVAC)
- Radio
- Driver Door Switch (DDS), connected through the left I/P fuse block
- Passenger Door Switch (PDS), connected through the right I/P fuse block

DataLink Communications Description and Operation (cont'd)

Body Splice

- Articulating Running Board Module (ARBM)
- Ultrasonic Park Assist (UPA)
- Memory Seat Module (MSM)
- Liftgate Module (LGM)
- Passenger Presence System (PPS)
- Inflatable restraint vehicle Rollover Sensor (ROS)
- Inflatable restraint Sensing and Diagnostic Module (SDM)

Serial Data Reference

The scan tool communicates over the various busses on the vehicle. When a scan tool is installed on a vehicle, the scan tool will try to communicate with every module that could be optioned into the vehicle. If an option is not installed on the vehicle, the scan tool will display No COMM for that options specific control module.

In order to avert misdiagnoses of No Communication with a specific module, refer to **Data Link References** for a list of modules, the busses they communicate with, and the Regular Production Option (RPO) codes for a specific module.

Electric Power Management – Description and Operation

Electric Power Management

The Electric Power Management (EPM) is used to monitor and control the charging system and alert the driver of possible problems within the charging system. The EPM system makes the most efficient use of the generator output, improves the battery State Of Charge (SOC), extends battery life.

The idle boost operation is a means of improving generator performance during a low voltage or low battery SOC condition.

Idle boost is activated in incremental steps, idle boost 1 must be active before idle boost 2 can be active. The criteria used by the Body Control Module (BCM) to regulate EPM are outlined below.

Function	Battery Temperature Calculation	Battery Voltage Calculation	Amp-hour Calculation	Action Taken
Idle Boost 1 Start	Less Than -15°C (+5°F)	Less Than 13 V	--	First Level Idle Boost Requested
Idle Boost 1 Start	--	--	Battery has a net loss greater than 0.6 AH	First Level Idle Boost Requested
Idle Boost 1 Start	--	Less Than 10.9 V	--	First Level Idle Boost Requested
Idle Boost 1 End	Greater Than -10°C (+5°F)	Greater Than 12 V	Battery has a net loss less than 0.2 AH	First Level Idle Boost Request Cancelled
Idle Boost 2 Start	--	--	Battery has a net loss greater than 1.6 AH	Second Level Idle Boost Requested
Idle Boost 2 Start	--	Less Than 10.9 V	--	Second Level Idle Boost Requested
Idle Boost 2 End	--	Greater Than 12 V	Battery has a net loss less than 0.8 AH	Second Level Idle Boost Request Cancelled
Idle Boost 3 Start	--	--	Battery has a net loss of 10.0 AH	Third Level Idle Boost Requested
Idle Boost 3 End	--	Greater Than 12 V	Battery has a net loss of less than 6 AH	Third Level Idle Boost Request Cancelled

Power Mode – Description and Operation

Serial Data Power Mode Master

Power to many of this vehicles circuits is controlled by the module that is designated the Power Mode Master (PMM). This vehicle's PMM is the Body Control Module (BCM). The ignition switch is a low current switch with multiple discrete ignition switch signals to the PMM for determination of the power mode that will be sent over the serial data circuits to the other modules that need this information. The PMM will also activate relays and other direct outputs of the PMM as needed. The PMM determines which power mode (Off, Accessory, Run, Crank Request) is required, and reports this information to other modules via serial data. Modules which have switched voltage inputs may operate in a default mode if the PMM serial data message does not match what the individual module can see from its own connections.

The PMM receives ignition switch signals to identify the operators desired power mode. The PMM Power Mode Parameters table below illustrates the correct state of these input parameters (circuits) in correspondence to the ignition switch position:

PMM Power Mode Parameters Ignition Switch Position	Power Mode Transmitted	Ignition Off/Run/Crank (Run Crank Ignition 1 Voltage Circuit)	Ignition Accessory/Run (Accessory Voltage Circuit)	Ignition Run/Crank (Ignition 1 Voltage Circuit)
Off Key Out	Off	Key Out/ACC	Inactive	Inactive
Off Key In	Off	Key In/Off	Inactive	Inactive
Accessory	Accessory	Key Out/ACC	Active	Inactive
Run	Run	Run	Active	Active
Start	Crank Request	Crank	Inactive	Active

Relay Controlled Power Mode

The BCM uses the discrete ignition switch inputs Run/Crank Ignition 1 Voltage, Accessory Voltage, and Ignition 1 Voltage, to distinguish the correct power mode. The BCM, after determining the desired power mode, will activate the appropriate relays for that power mode.

The RAP relay remains on for a timed period after the Ignition key is removed. Refer to ***Retained Accessory Power (RAP) Description and Operation*** for more information on the RAP function.

Power Mode – Description and Operation (cont'd)

BCM Awake/Sleep States

The Body Control Module (BCM) is able to control or perform all of the BCM functions in the awake state. The BCM enters the sleep state when active control or normal monitoring of system functions has stopped and a time limit has passed. The BCM must detect certain wake-up inputs before entering the awake state. The BCM monitors for these inputs during the sleep state.

The BCM will enter the awake state if **any** of the following wake-up inputs are detected:

- Activity on the serial data line
- Detection of a battery reconnect
- Any door open signal
- Headlamps ON
- Key-in-ignition
- Ignition ON
- Park lamps ON
- Keyless entry or remote start message

The BCM will enter a sleep state when **all** of the following conditions exist:

- The ignition switch is OFF, key out.
- No activity exists on the serial data line.
- No outputs are commanded.
- No delay timers are actively counting.
- No wake-up inputs are present.

If all these conditions are met, the BCM will enter a low power or sleep condition.

Retained Accessory Power (RAP) – Description and Operation

Serial Data Control of Retained Accessory Power (RAP)

The modules receive the power mode message from the Body Control Module (BCM) over the serial data circuits, indicating when the Retained Accessory Power (RAP) power mode is current. The BCM monitors the ignition switch position, battery condition and passenger compartment doors status to determine whether RAP should be initiated. The modules then support the operation of the systems under their control as required by their RAP power mode operation. Components and systems that are active in RAP are also activated anytime the ignition is any position other than OFF.

The BCM sends a serial data power mode message ending the RAP function when one of the following conditions is met:

- The BCM receives an input indicating the opening of any passenger compartment door after the ignition key is out of the ignition.
**Important: The only door that will turn off the radio during RAP is the driver door.
This is a function of the radio and will still turn off after the time limit.**
- The BCM internal timer for the RAP expires after approximately 10 minutes.
- The BCM detects a decrease in battery capacity below a prescribed limit.

Relay Control of Retained Accessory Power (RAP)

The BCM keeps the Retained Accessory Power (RAP) relay energized during all power modes, except Off-Awake and Crank. The relay is also energized for approximately 10 minutes after shutting the ignition OFF and removing the key, providing no door is opened. The BCM will de-energize the RAP relay at the same time as the serial data message is sent to end RAP.

The devices powered by the accessory relay during the RAP power mode are the sunroof, power window switches and Brake Transmission Shift Interlock (BTSI)/Park Lock.

Power Take-Off (PTO) – Bulletin #79

Bulletin #79

The all new PTO Subsystem Factory Options include all components & wiring for a tested functional system (speed control). Two Bulletins are offered to describe the system.

Bulletin #79 provides a brief description

The bulletin shows the location of the following components included with the option:

1. New Driver control switch.
2. New PTO module
3. New 16-way connector for user interface.

The bulletin contains the following sections

1. System Overview
2. Detailed Functional Description
3. Standard vs. Optional Features

The link to Bulletin #79 is

http://www.gmupfitter.com/publicat/bull/52993_UpfitBltn79_D4.pdf

Note: These bulletins address the "All New," not the "Classic" C/K truck.

Power Take-Off (PTO) – Bulletin #80 rev 1

Bulletin #80rev1 Bulletin #80rev1 is a complete Operating Description and Application Guide. The Table of contents is as follows:

1. OVERVIEW	4	6. REMOTE ENGINE START AND SHUTDOWN CONTROL	16
1.1. NEW FEATURES FOR MODEL YEAR 2007	4	6.1. REMOTE ENGINE SHUTDOWN	16
2. PTO COMPONENTS	5	6.2. REMOTE ENGINE START	16
2.1. FACTORY INSTALLED PTO COMPONENTS	5	7. REPROGRAMMING PTO	17
2.1.1. PTO IN-CAB SWITCH	6	7.1. PTO CONFIGURATION MODE SETTING	17
2.1.2. PTO GEAR	6	7.2. PTO FACTORY DEFAULT SETTINGS	18
2.1.3. PTO MODULE	6	8. PTO ELECTRICAL WIRING CONNECTIONS	20
2.1.4. PTO UPFITTER CONNECTOR	6	8.1. REMOTE ENGINE START SWITCH CIRCUIT	20
2.2. AFTERMARKET UPFITTER/BODY BUILDER ADD-ON COMPONENTS	6	8.2. REMOTE ENGINE SHUTDOWN SWITCH CIRCUIT	20
2.2.1. PTO RELAY	6	8.3. REMOTE PTO ARMING AND ENABLE (“ON”/“OFF”) SWITCH CIRCUITS	21
2.2.2. REMOTE PTO ENABLE SWITCH	6	8.4. REMOTE PTO SET SPEED SWITCH CIRCUIT	21
2.2.3. REMOTE ENGINE START SWITCH	7	8.5. REMOTE ACCELERATOR CIRCUIT	22
2.2.4. REMOTE ARMING SWITCH	7	8.6. PTO LOAD RELAY AND LOAD FEEDBACK CIRCUITS	23
2.2.5. REMOTE ENGINE SHUTDOWN SWITCH	7	8.7. REMOTE PTO INDICATOR CIRCUIT (MY2009)	24
2.2.6. REMOTE PTO SET SWITCH	7	8.8. REMOTE TACHOMETER CIRCUIT (MY2009)	24
2.2.7. REMOTE PTO ACCELERATOR SENSOR	7	9. APPENDIX A: UPFITTER MATING CONNECTOR	25
3. PTO OPERATION	7	9.1. CONNECTOR COMPONENTS	25
3.1. PTO ENABLING CONDITIONS	7	9.2. CONNECTOR PIN FUNCTIONS	26
3.1.1. STATIONARY PTO ENABLING CONDITIONS	7	10. APPENDIX B: PTO APPLICATIONS	27
3.1.2. MOBILE PTO ENABLING CONDITIONS	8	10.1. STATIONARY PTO - FULL FUNCTION SYSTEM	29
3.2. PTO DISENGAGE CONDITIONS	8	10.2. TOW TRUCK / VEHICLE HAULER	31
3.2.1. STATIONARY PTO ADDITIONAL DISENGAGE CONDITIONS	8	10.3. LIFT BUCKET / LIFT GATE	33
3.2.2. MOBILE PTO ADDITIONAL DISENGAGE CONDITIONS	9	10.4. WATER PUMPING OPERATION / ELECTRIC GENERATOR / LIFT GATE	35
4. DRIVER WARNINGS	9	10.5. AIR COMPRESSOR / A/C COMPRESSOR	37
4.1. DRIVER INFORMATION CENTER (DIC) WARNING MESSAGES	9	10.6. SNOW PLOW / SALT SPREADER / FERTILIZER SPREADER / ROAD GRADER / STREET SWEEPER / DUMP BOX	39
4.2. PROLONGED OR EXTENDED PTO OPERATION	10	11. APPENDIX C: PTO MODULE HARNESS CONNECTOR	41
5. ENGINE SPEED CONTROL MODES	10	12. APPENDIX D: SERVICE DIAGNOSTICS	44
5.1. PRESET PTO MODE	10	12.1. DIAGNOSTIC TROUBLE CODES	44
5.1.1. IN-CAB PTO SET SWITCH OPERATION	10		
5.1.2. REMOTE PTO SET SWITCH OPERATION	11		
5.1.2.1. MOMENTARY SET SWITCH OPERATION	11		
5.1.2.2. LATCHING SET SWITCH OPERATION	11		
5.2. VARIABLE PTO MODE	13		
5.2.1. IN-CAB PTO SWITCH OPERATION	15		
5.2.2. REMOTE PTO SWITCH OPERATION	15		

The Link to Bulletin #80rev1 is:

http://www.gmupfitter.com/publicat/bull/63135_PTO_Bulletin_80_D8.pdf

Power Take-Off (PTO) – Fast Idle (UF3) Overview

PTO

Engine rpm is adjusted with an IP mounted activation switch. There are two engine rpm selections available which are preset at the factory. Engine RPM settings and PTO modes can be modified at the dealer with GM Tech tool. PTO price includes Switch, PTO Module, DIC messages, dedicated wiring for easy interface and, power-take-off gear in transmission. PTO access is available on driver side only, (K34 Cruise Control is not required, N/A with UF3 high idle). PTO can't be added later if not ordered.

PTO Controls Location

The PTO switch is mounted in the right side of the center instrument panel as part of the factory-installed PTO package. The PTO switch is a four position rocker type.



For complete information about this option, see GM Upfitter Bulletin #80re at: http://www.gmupfitter.com/publicat/bull/63135_PTO_Bulletin_80_D8.pdf

UF3 – Fast Idle

- UF3 is available on some 2008 trucks
- To obtain Fast Idle capability on 2008 trucks, you must order:
 1. 2500/3500 Series – UF3 is not available on 1500 Series trucks
 2. 6.0L (LY6) Gas Engine or 6.6L (LMM) Diesel Engine
 3. Cruise Control Option (K34)
 4. Fast Idle Option (UF3)
- UF3 cannot be retrofitted on 2008 trucks – no kits are available

For complete information about this option, see GM Upfitter Bulletin #82 at:

http://www.gmupfitter.com/publicat/bull/63135_FastIdle_UI_82_D3.pdf

Snowplow/Front Lighting – Prep (VYU) Electrical Provisions

Index

Overview - Snowplow Prep (VYU) Electrical ProvisionsA-12

**Emergency Roof Beacon – Option TRW –
Description & Schematic – A5 - A9**A-13

GMT900 GeneratorsA-18

Accessory Harness Grommet (figure3) & Dash Panel Dwg.....A-19

Chevy SUV (X88)

- Chevrolet SUV Front of Vehicle View – ID# 1729884A-21
- Chevrolet SUV Forward Lamp OverviewA-22
- Front Fascia Harness & Connector location drawing – C-12.....A-23
- X100 Left headlamp Connector – C-6.....A-24
- X106 Right headlamp connector - C-9.....A-25
- Headlamp Replacement – Chevy - ID#1706059.....A-26
- Headlamp Bulb Replacement – Chevy - ID #1706616A-27

GMC SUV (Z88)

- GMC SUV Front of Vehicle View – ID #1776483A-28
- GMC SUV Forward Lamp OverviewA-29
- Front Fascia Harness & Connector location drawing C-13A-30
- X101 Left Front Lamp (Turn/Park) connector – C-7A-31
- X104 Right Front Lamp (Turn/Park) connector – C-8.....A-31
- X107 Left headlamp (VYU) connector – C10.....A-32

GMC SUV (Z88) – (cont'd)

- X108 Right headlamp (VYU) connector – C11.....A-33
- Headlamp Replacement – GMC - ID#1761592.....A-34
- Headlamp Bulb Replacement – Yukon – ID # 1706624A-35

Pickups - Chevy (X88) & GMC (Z88)

- Chevy Silverado Pickup Front Lights – ID# 1858094A-36
- GMC Sierra Pickup Front Lights – ID# 1858068A-37
- Chevy/GMC Forward Lamp Overview.....A-38
- Forward Lamp Harness (Diesel) - ID#1848908.....A-39
- Pickup - X100 Left headlamp Connector – C-1A-40
- Pickup - X106 Right headlamp connector – C-2.....A-41
- Headlamp Replacement – GMC - ID #184500.....A-42
- Headlamp Bulb Replacement – Chevy - ID #1836077.....A-43
- Replacement BulbsA-44

Snowplow Prep Package (VYU) Electrical Provisions

Emergency Roof-Mounted Lamp Switch

This provision includes an over head console mounted switch , a relay, and wiring which terminates at the roof as coiled blunt cut wires – Option TRW. There are two blunt cut 12-gauge (3.0 mm²) wires, one is Dark Green (roof-mounted lamp power), it is controlled by the over head console -mounted switch through the relay, the other is Black (ground). The Dark Green power wire is protected by the 30-Amp S/ROOF fuse #33 which is located in the Underhood Electrical Center.

VYU Generators

- On 1500/2500 Series trucks equipped with Gas Engines, the VYU option provides upgrade to a larger 160 amp output generator
- On 2500/3500 Series trucks equipped with Diesel Engines, the VYU option provides upgrade to dual 125 amp generators
- Refer to the Generator Chart on page A-18

Accessory Harness Grommet

Trucks will come equipped with a predrilled 42mm pass-through hole located on the dash panel on the left hand side of the vehicle. The hole will be sealed with a grommet (see Figure 3) which can be used by the upfitter for pass-through wiring. To use the grommet (part# 15336702), the upfitter slices off the tape tab end (in engine compartment) of the grommet and then spreads it open to pass wiring through.

Forward Lamp Harness In-Line Connectors

The turn signals are driven from the BCM. Changes in turn signal current may require the use of additional relays. The Studs on the UBEC can be used for battery power for the relays. This wire requires a separate in-line fuse.

The Chevrolet (X88) and GMC (Z88) utilities have different forward lamps.

- Chevrolet forward lamp wiring harness will have a set of mating eight cavity connectors on both the left and right hand side of the vehicle The upfitter will be able to disconnect the in-line connectors which will allow interfacing with the forward lamp circuits (Front Parklamp, Turn Signal and DRL). The headlamp circuits may be accessed from the headlamp connectors.
- GMC lamp wiring harness will have a set of mating 3 cavity connectors on both the left and right hand side of the vehicle for Turn Signal and Park Lamps. High and Low beams do not have an in-line connector. The VYU options adds an additional set of mating 3 cavity connectors on both the left and right hand side of the vehicle for High and Low beams.

The Chevrolet (X88) and GMC (Z88) pickups have the same forward lamps.

- These are similar to the Chevrolet utility. The difference is the utilities have a separate Daytime Running Lamp (DRL). The Pickups use a reduced intensity Low Beam Headlamp for DRL. Both the pickups and the Chevrolet utility use the same eight cavity connectors for the forward lamp wiring. The difference is the pickups have no connection for the DRL.

Backup Lamp Power Feed

A backup lamp power feed is provided at the rear of the vehicle through the trailer wiring harness as a standard feature. This circuit is protected by the 10-Amp TRLR B/U fuse which is located in the Under hood Electrical Center. On vehicles with Light Duty Trailer Wiring this circuit can be accessed through the Light Green trailer wire. This wire is located in pin A of the trailer connector at the rear of the vehicle (see figure 6). On vehicles with Heavy Duty Trailer Wiring option, this connector is mated with a socket at the rear of the vehicle (see figure 7).

Roof Mounted Beacon (TRW)

Battery power is supplied through a 30 amp fuse to a wiring harness located in the roof. Power is controlled with a switch located in the overhead console. The customer or vehicle upfitter must complete the installation to an added accessory such as an emergency beacon lamp.

Maximum rated electrical load is 21 amps (250 watts). The added electrical requirements must not exceed 21 amps (250 watts). Running the accessory for long periods of time with the engine off may run the battery down.

Installation Instructions – Emergency Vehicle Roof Panel Lamp

Wiring to the accessory can be done by either directly connecting the wire in the roof to the accessory (Option A) or by using Wiring Harness Package part number 12150250 obtained from GM Service Parts (Option B).

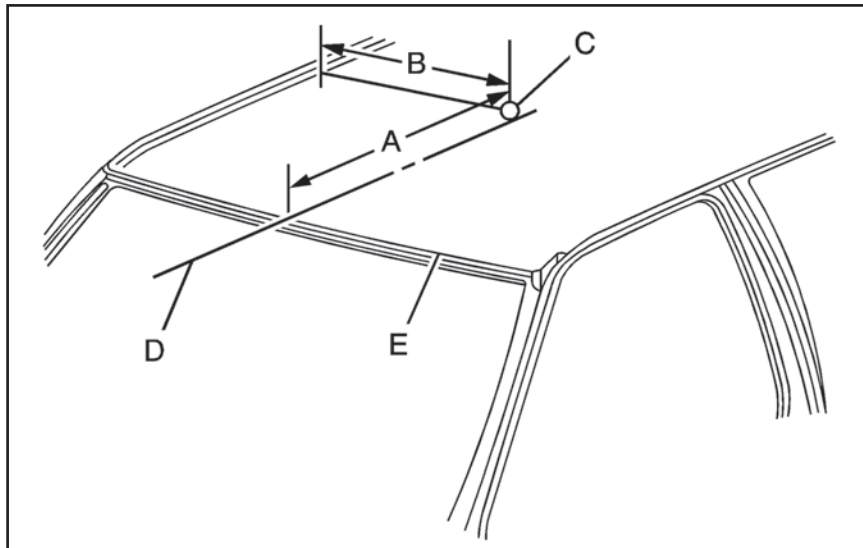

- A. 25.39 inches (645 mm)
- B. 17.32 inches (440 mm)
- C. 3.94 inches (100 mm)
- D. Roof Centerline
- E. Roof Edge

Roof Mounted Beacon (TRW) (cont'd)

Emergency Vehicle Roof Panel Lamp (continued from previous page)

1. Disconnect the battery negative (-) cable at the battery.
2. Make the electrical connections using either option A or option B.

Notice: Pulling the wiring harness through a panel hole that has sharp edges may cause damage to the wire and/or wire insulation. Remove sharp edges from the panel hole before pulling the wire through it.

Option A: Roof Wires Directly to Accessory

1. Drill a 3/8 inch to 1/2 inch (10 to 13 mm) hole in the outer roof panel in the area shown in the illustration. The hole should only go through the outer panel. Remove all sharp edges from the drilled hole.
2. Remove the inside overhead console access panel/lamp lenses.
3. The accessory harness is coil tied to the passenger's side of the vehicle at the console inner bracket.
4. Cut the tape holding the harness coil.
5. As one person watches the roof hole from the outside for the end of the harness, a second person from the inside of the vehicle should snake the harness toward the hole.
6. Pull out the wiring harness being careful to avoid scraping the insulation on the edge of the hole.
7. Extend the wiring harness to the accessory.
8. Connect the dark green wire to the accessory hot terminal.
9. Connect the black wire to the accessory ground terminal.
10. Cover the hole in the roof with a durable sealant such as silicone rubber sealer.
11. Reinstall the overhead console access panel/lamp lenses.

Option B: Use Wiring Harness Package 12150250. Obtain from GM Service Parts through the GM Dealership

1. Drill a 1.25 inch (32 mm) hole in the outer roof panel in the area shown in the illustration. The hole should only go through the outer panel. Remove all sharp edges from the drilled hole.
2. Remove the inside overhead console access panel/lamp lenses.
3. The accessory harness is coil tied to the passenger's side of the vehicle at the console inner bracket.
4. Cut the tape holding the harness coil.
5. As one person watches the roof hole from the outside for the end of the harness, a second person from the inside of the vehicle should snake the harness toward the hole.
6. Pull out the wiring harness being careful to avoid scraping the insulation on the edge of the hole.
7. Cut the wire to length. Install terminals to wire ends and insert into the connector. The brown wire goes to cavity A and the black wire in cavity B. Push in the secondary lock to retain the wires.
8. Attach the harness assembly from the package to the accessory. Cover with the supplied conduit for added protection. Connect the orange wire to the accessory hot terminal and the black wire to the ground.
9. Complete the connection from the roof harness to the extension harness. Cover the mated connector with the supplied foam. Push the foam covered connection and excess wire through the roof panel hole.
10. Reinstall the overhead console access panel/lamp lenses.

Roof Mounted Beacon (TRW) – Restoring Power

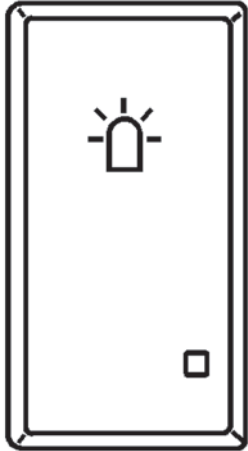

The auxiliary lamp switch is located on the overhead console.

This switch includes wiring provisions for a dealer or a qualified service center to install an auxiliary roof lamp. When the wiring is connected to an auxiliary roof mounted lamp, pressing the bottom of the switch will activate the lamp and illuminate an indicator light at the bottom of the switch. Pressing the top of the switch again will turn off the roof mounted lamp and indicator.

1. Be sure that the auxiliary lamp switch is off.
2. Reconnect the battery negative cable.
3. Turn the auxiliary lamp switch on. The accessory should now be working. If it is not working, check the connections.
4. After ensuring that the accessory is working properly, install the grommet in the hole. Seal with silicone sealer to prevent water leakage.

Notice: Overloading the vehicle's electrical system may damage your vehicle's accessories.
Do not overload the vehicle's system by having unnecessary accessories on at the same time.

Roof Mounted Beacon (TRW)

Option B

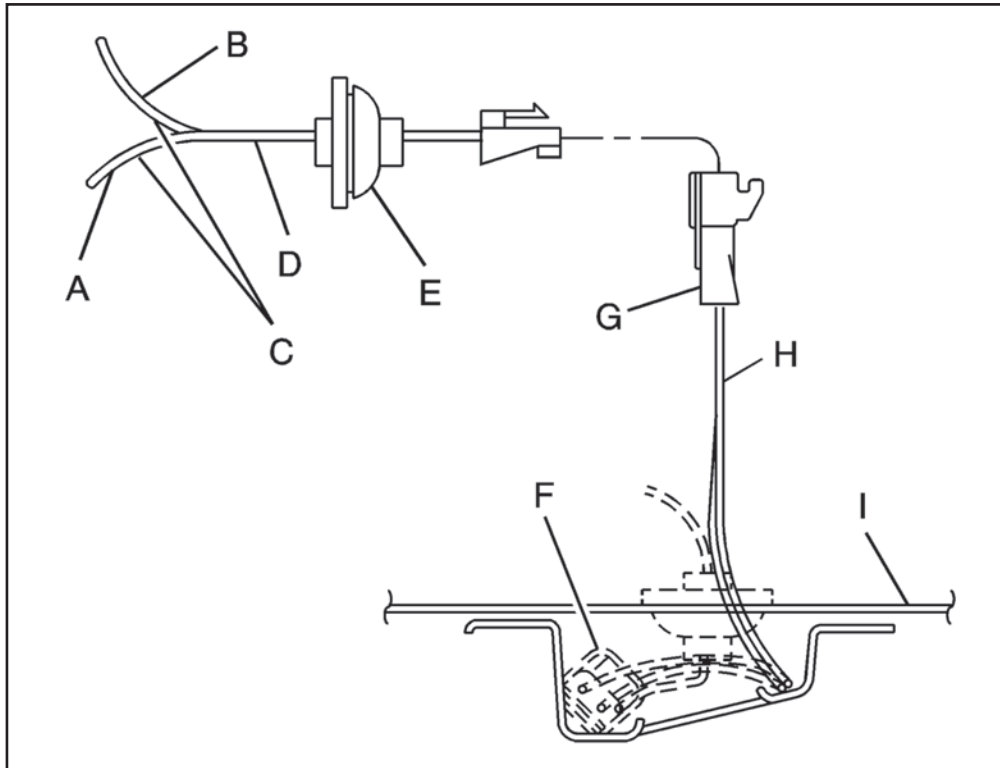

- A. Black Wire
- B. Orange Wire
- C. To Roof Mounted Lamp
- D. Harness Assembly
- E. Grommet (Roof)
- F. Foam Insulator (Adhesive-Backed)
- G. Harness Connector, Secondary Lock and Terminal
- H. Brown Black Wire
- I. Vehicle Outer Roof Panel

Roof Mounted Beacon (TRW)

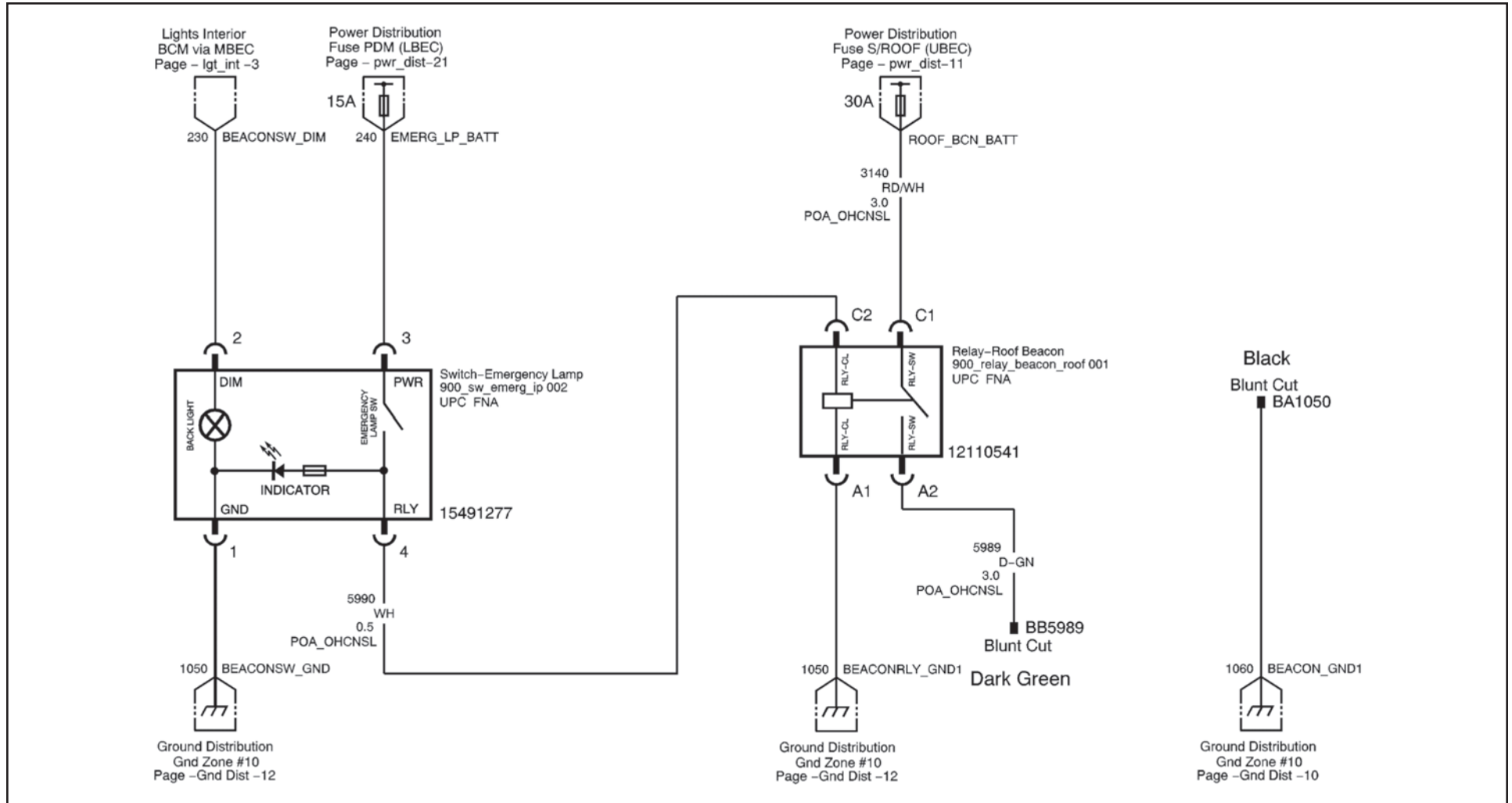

Maintenance

The circuit is fed from the #2 post on the underhood electrical center and protected by the fuse labeled #2 post located in the electrical center. Always replace the fuse with a 30 amp maxi-fuse.

Generator Usage

Vehicle Type	Vehicle Series	Options and/or Special Equipment	Engine Cooling Fans	Engine Type	Generator RPO/Make/Model	Generator Output (Amps)
Utility – Light Duty	10	Base	Dual Electric	Gas	KW1 / Remy / DR44M	160
Utility – Heavy Duty	20	Base	Engine Driven	Gas	KG3 / Remy / DR44M	145
	20	VYU – Snow Plow	Engine Driven	Gas	KW1 / Remy / DR44M	160
Pickup – Light Duty	10	Base	Dual Electric	Gas	KG3 / Remy / DR44M	145
	10	VYU – Snow plow	Dual Electric	Gas	KW1 / Remy / DR44M	160
Pickup – Heavy Duty	20/30	Base	Engine Driven	Gas/Diesel	KG7 / Bosch / E6	125
	20/30	VYU – Snow Plow	Engine Driven	Gas	KW1 / Remy / DR44M	160
	20/30	VYU – Snow Plow	Engine Driven	Diesel	K76 / Bosch / E6 X 2	125 X 2 = 250
	20/30	K76 – Dual Generators	Engine Driven	Diesel	K76 / Bosch / E6 X 2	125 X 2 = 250

Generator RPO's

- **125 Amp** **KG7**
- **145 Amp** **KG3**
- **160 Amp** **KW1**
- **125 Amp X 2** **K76**

Accessory Harness Grommet

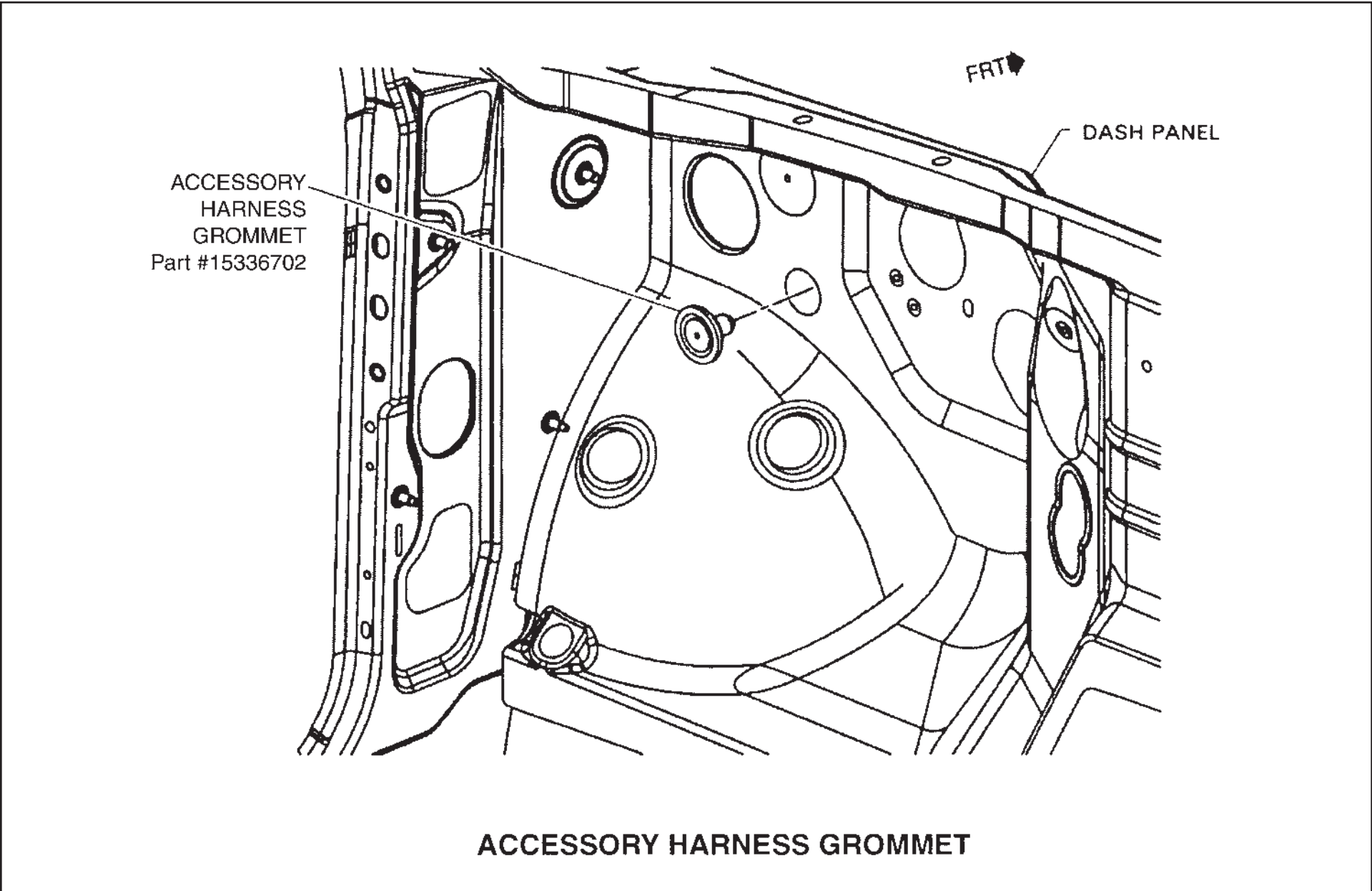

VYU Hole Location

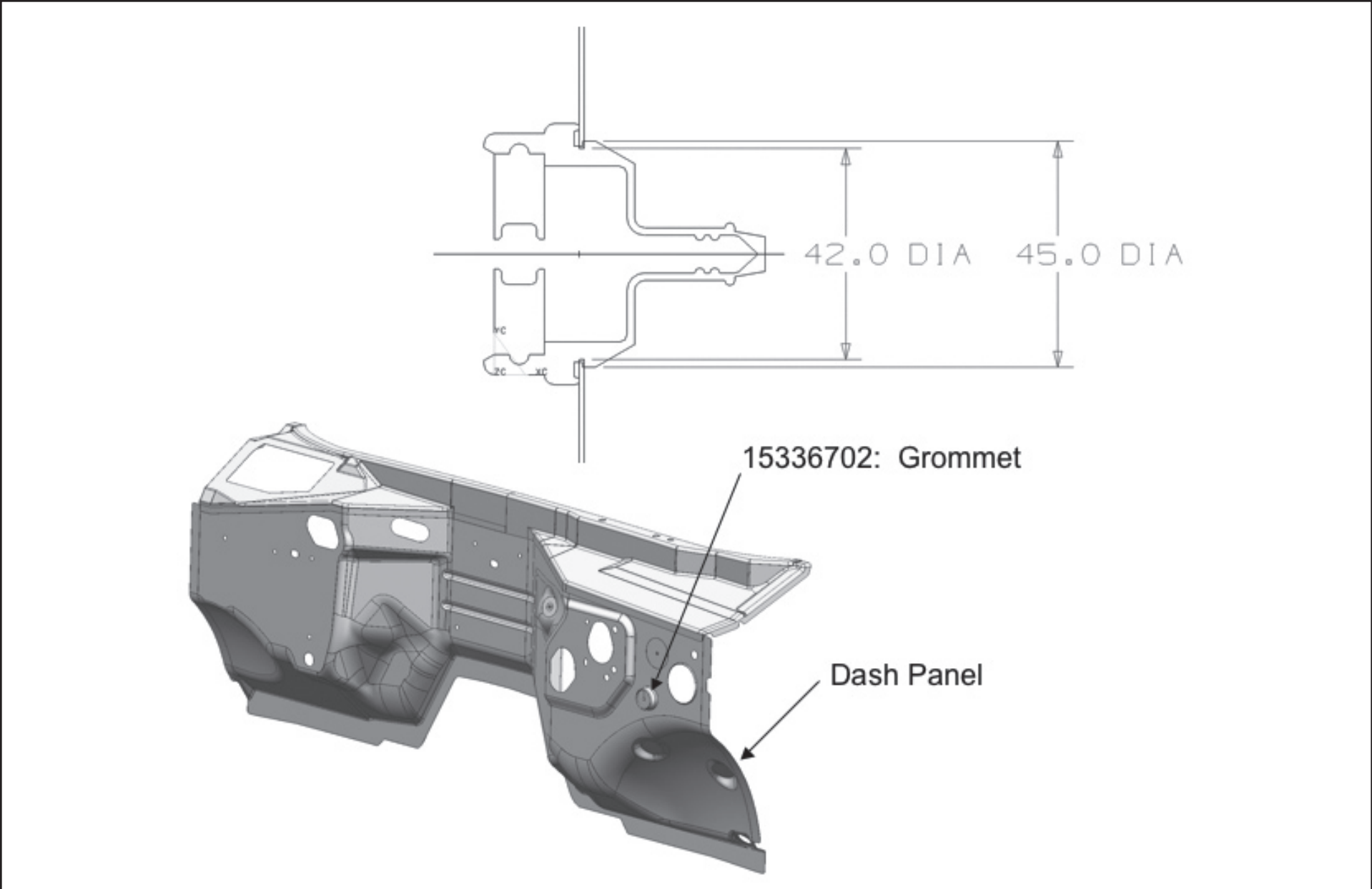

Chevrolet Tahoe SUV (X88)

Front of the Vehicle (X88)

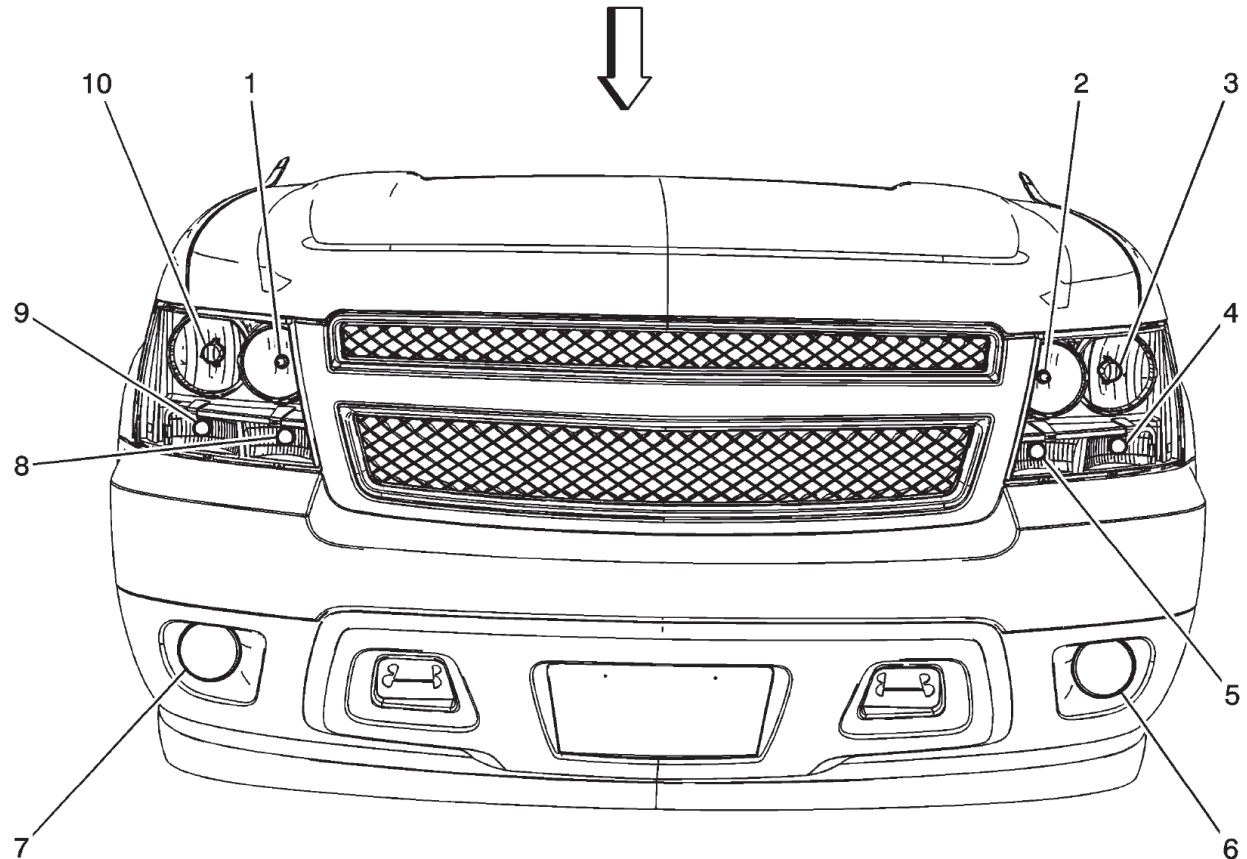

1. Headlamp - High Beam - Right
2. Headlamp - High Beam - Left
3. Headlamp - Left
4. Park/Turn Signal Lamp - Left
5. Daytime Running Lamp (DRL) - Left
6. Fog Lamp - LF
7. Fog Lamp - RF
8. Daytime Running Lamp (DRL) - Right
9. Park/Turn Signal Lamp - Right
10. Headlamp - Right

Forward Lighting & Additional Turn Signals – Chevrolet Tahoe & Suburban (X88)

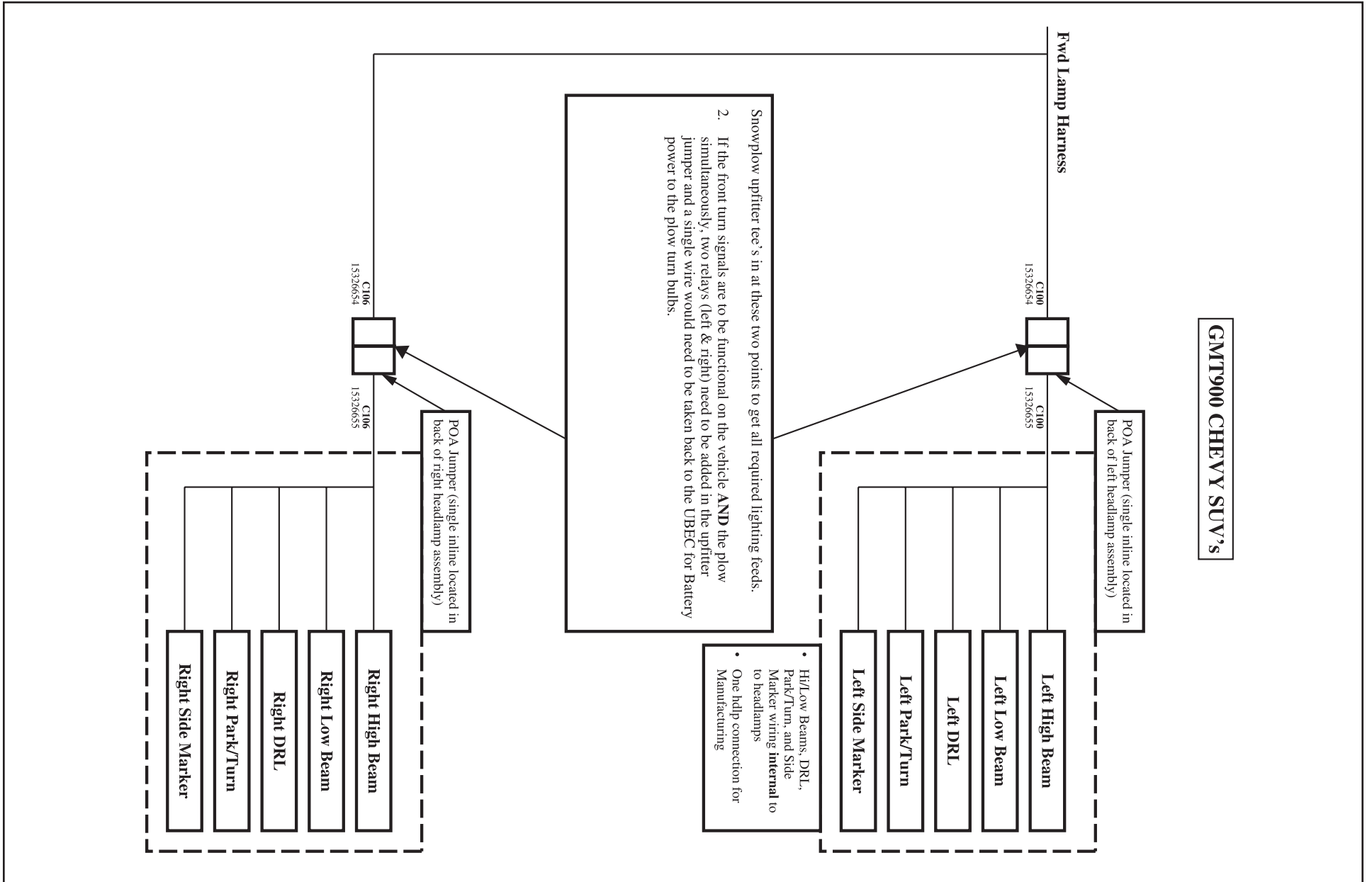

Front Fascia Harnesses Chevrolet Tahoe (X88)

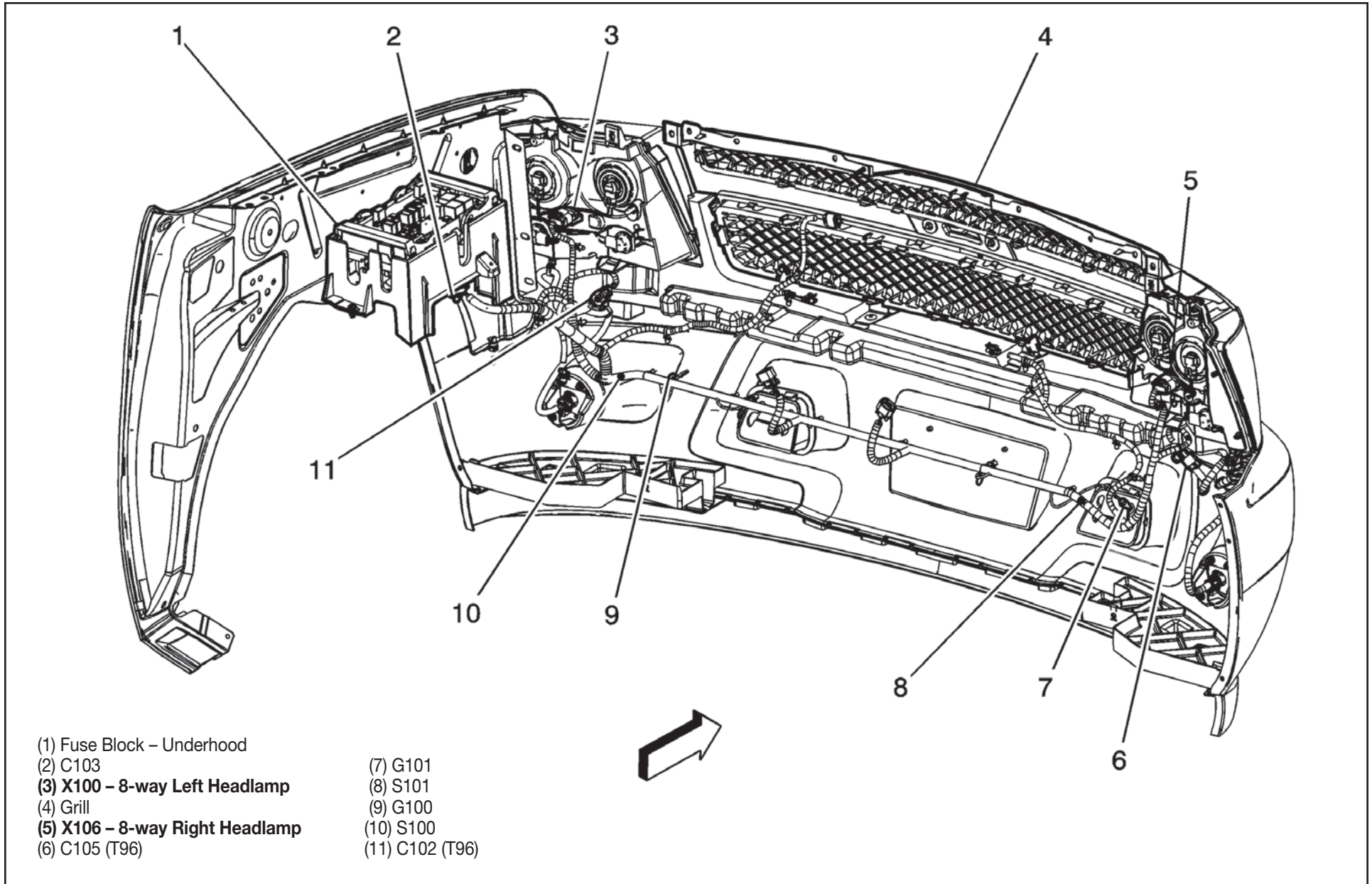

X100 Forward Lamp Harness to Left Headlamp Harness (X88-Z75)

Connector: 8-Way F GT 280 Series, Sealed (BK)
 O.E.M.: 15326654
 Color: **BLK**
 Service: 88986254

Pin	Wire Color	Circuit No.	Function
A	YE	712	Left Headlamp Low Beam Supply Voltage
B	BK	150	Ground
C	D-GN/WH	711	Left Headlamp High Beam Supply Voltage
D	--	--	Not Used
E	BN	2509	Left Rear Park Lamps Supply Voltage
F	BK	250	Ground
G	L-BU/WH	1314	Left Front Turn Signal Lamp Supply Voltage (X88)
H	--	--	Not Used

Connector: 8-Way M GT 280 Series, Sealed (BK)
 O.E.M.: 15326655
 Color: **BLK**
 Service: 15306424

Pin	Wire Color	Circuit No.	Function
A	YE	--	Left Headlamp Low Beam Supply Voltage
B	BK	--	Ground
C	D-GN/WH	--	Left Headlamp High Beam Supply Voltage
D	--	--	Not Used
E	BN	--	Left Rear Park Lamps Supply Voltage
F	BK	--	Ground
	BK	--	Ground
G	L-BU/WH	--	Left Front Turn Signal Lamp Supply Voltage (X88)
H	--	--	Not Used

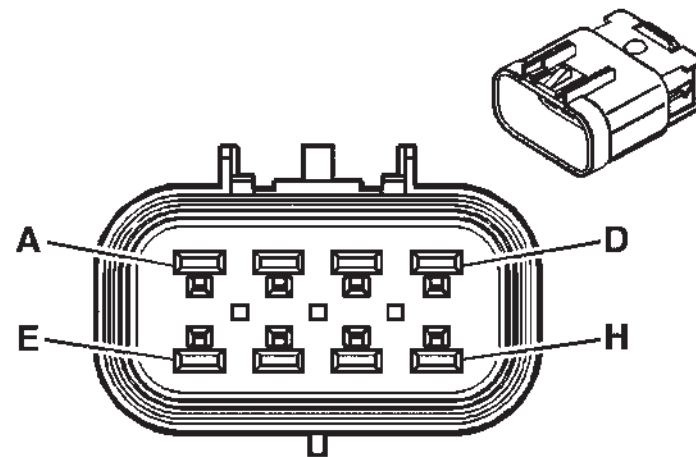
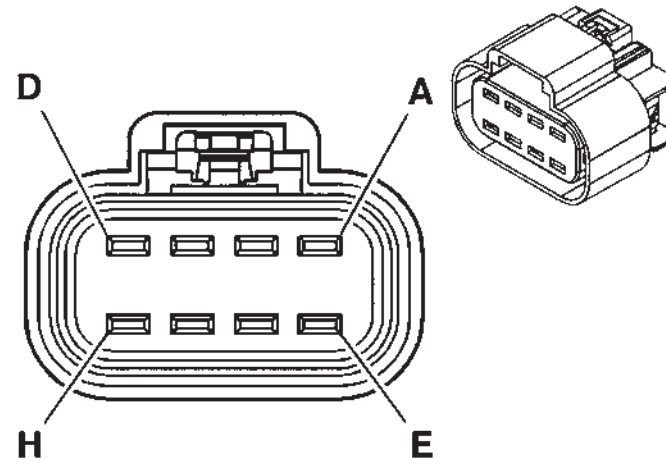

X106 Forward Lamp Harness to Right Headlamp Harness (X88 or Z75)

Connector: 8-Way F GT 280 Series, Sealed (BK)
 O.E.M.: 15326654
 Color: **BLK**
 Service: 88986254

Pin	Wire Color	Circuit No.	Function
A	TN/WH	312	Right Headlamp Low Beam Supply Voltage
B	BK	250	Ground
C	L-GN/BK	311	Right Headlamp High Beam Supply Voltage
D	--	--	Not Used
E	BN	2609	Right Rear Park Lamps Supply Voltage
F	BK	150	Ground
	BK	250	Ground
G	D-BU/WH	1315	Right Front Turn Signal Lamp Supply Voltage
H	--	--	Not Used

Connector: 8-Way M GT 280 Series, Sealed (BK)
 O.E.M.: 15326655
 Color: **BLK**
 Service: 15306424

Pin	Wire Color	Circuit No.	Function
A	TN/WH	--	Right Headlamp Low Beam Supply Voltage
B	BK	--	Ground
C	L-GN/BK	--	Right Headlamp High Beam Supply Voltage
D	--	--	Not Used
E	BN	--	Right Rear Park Lamps Supply Voltage
F	BK	--	Ground
	BK	--	Ground
G	D-BU/WH	--	Right Front Turn Signal Lamp Supply Voltage
H	--	--	Not Used

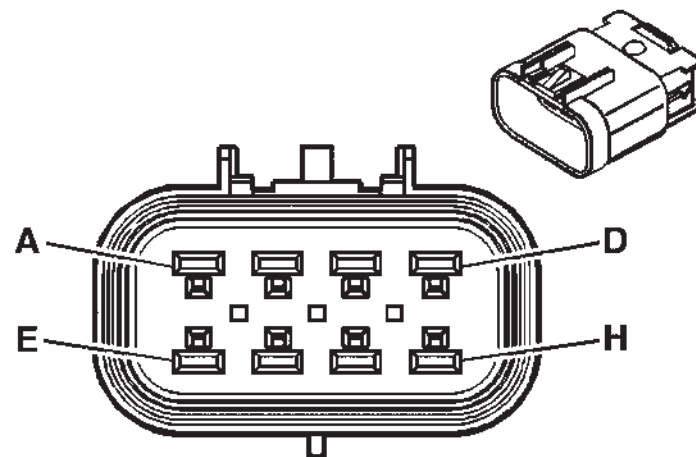
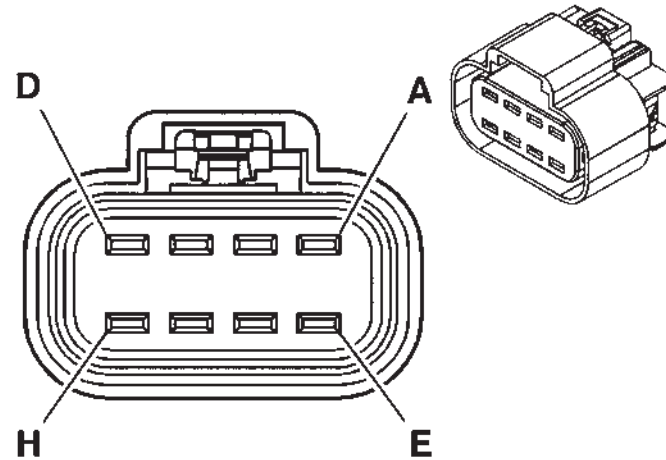

Headlamp Replacement – Chevrolet Tahoe SUV (X88)

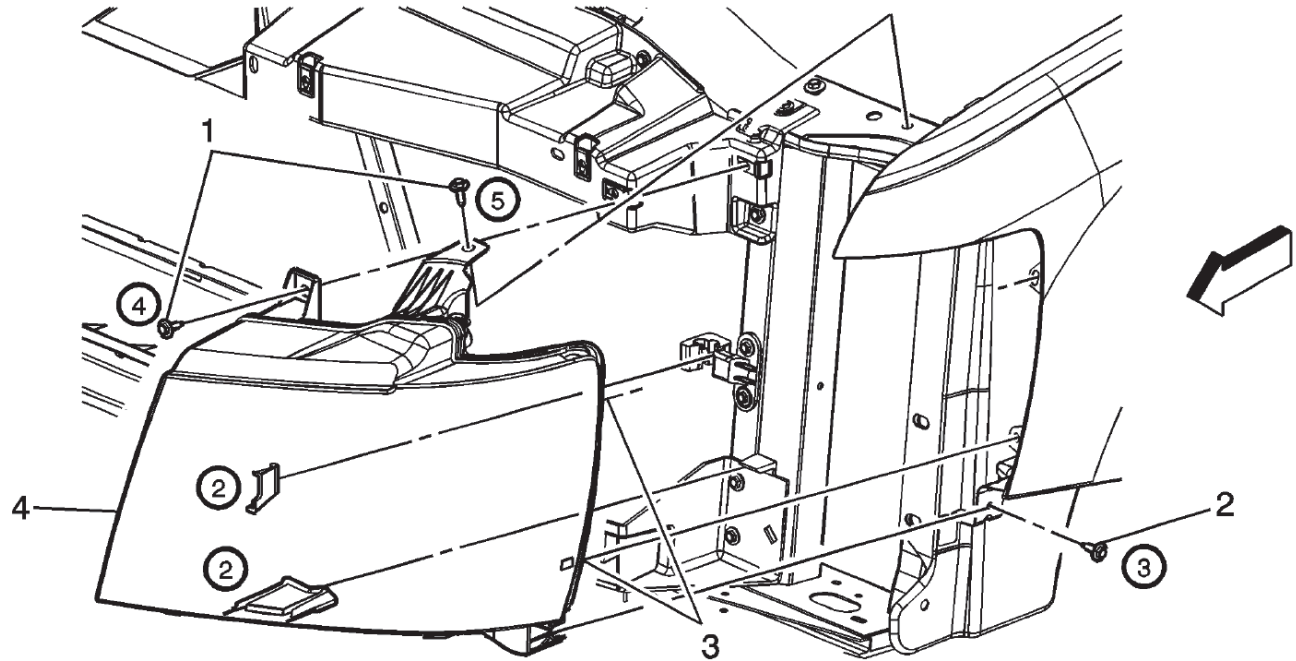

Callout	Component Name
Notice: Refer to Fastener Notice in Cautions and Notices. Fastener Tightening Specifications: Refer to Fastener Tightening Specifications .	
Preliminary Procedure Remove the grille assembly. Refer to Fascia Grille Replacement	
1	Headlamp Screw Tighten 9 N•m (80 lb in)
2	Headlamp Screw Tighten 2 N•m (18 lb in)
3	Headlamp Assembly Alignment Tabs Tip Pull to release the tabs on the back of the headlamp assembly
4	Headlamp Assembly Tip Disconnect the electrical connectors

Headlamp Bulb Replacement – Chevrolet Tahoe SUV (X88)

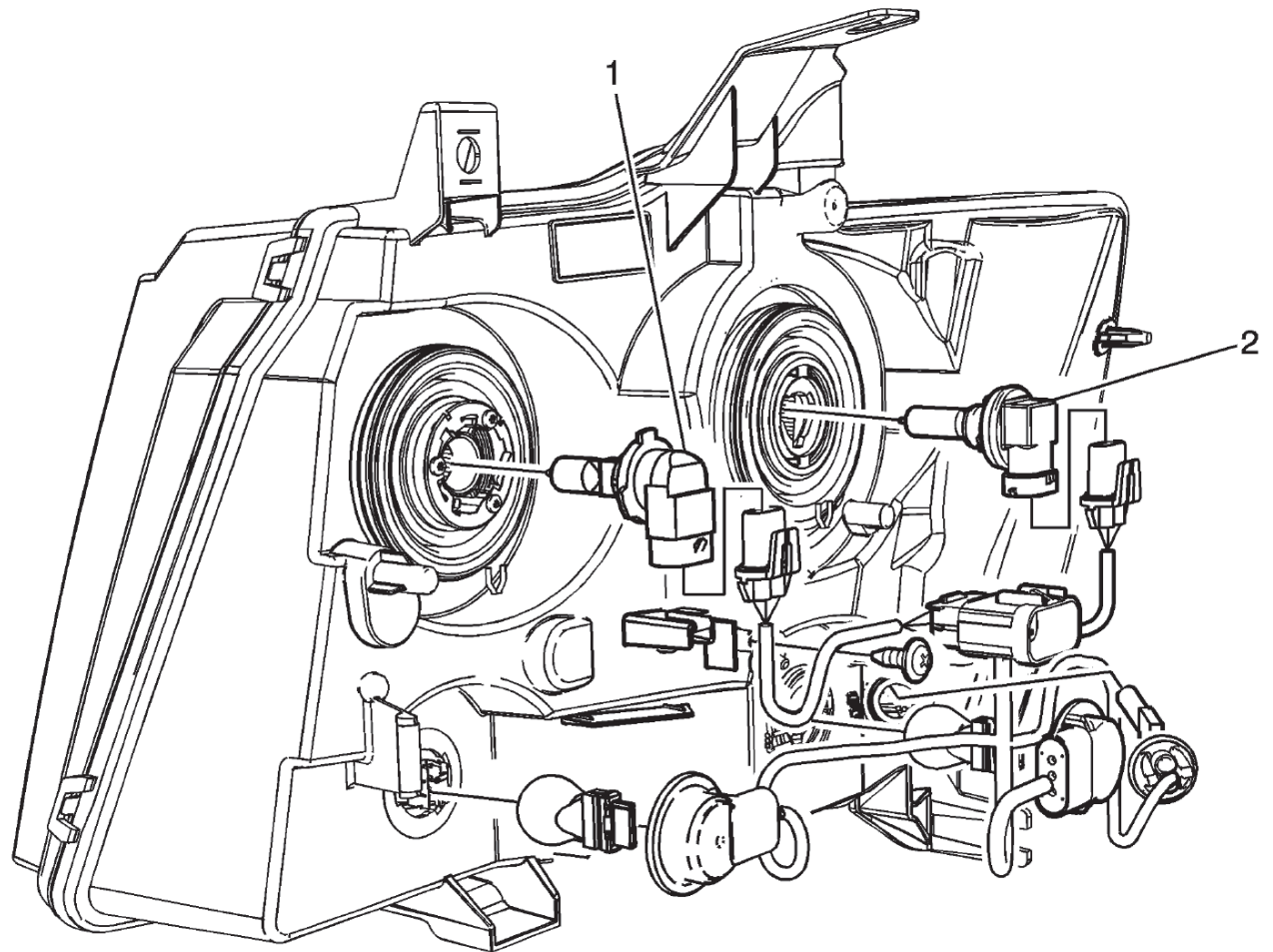

Callout	Component Name
Preliminary Procedure Remove the headlamp. Refer to Headlamp Replacement	
1	Low Beam Bulb
2	High Beam Bulb

Front of Vehicle View – GMC Yukon (Z88)

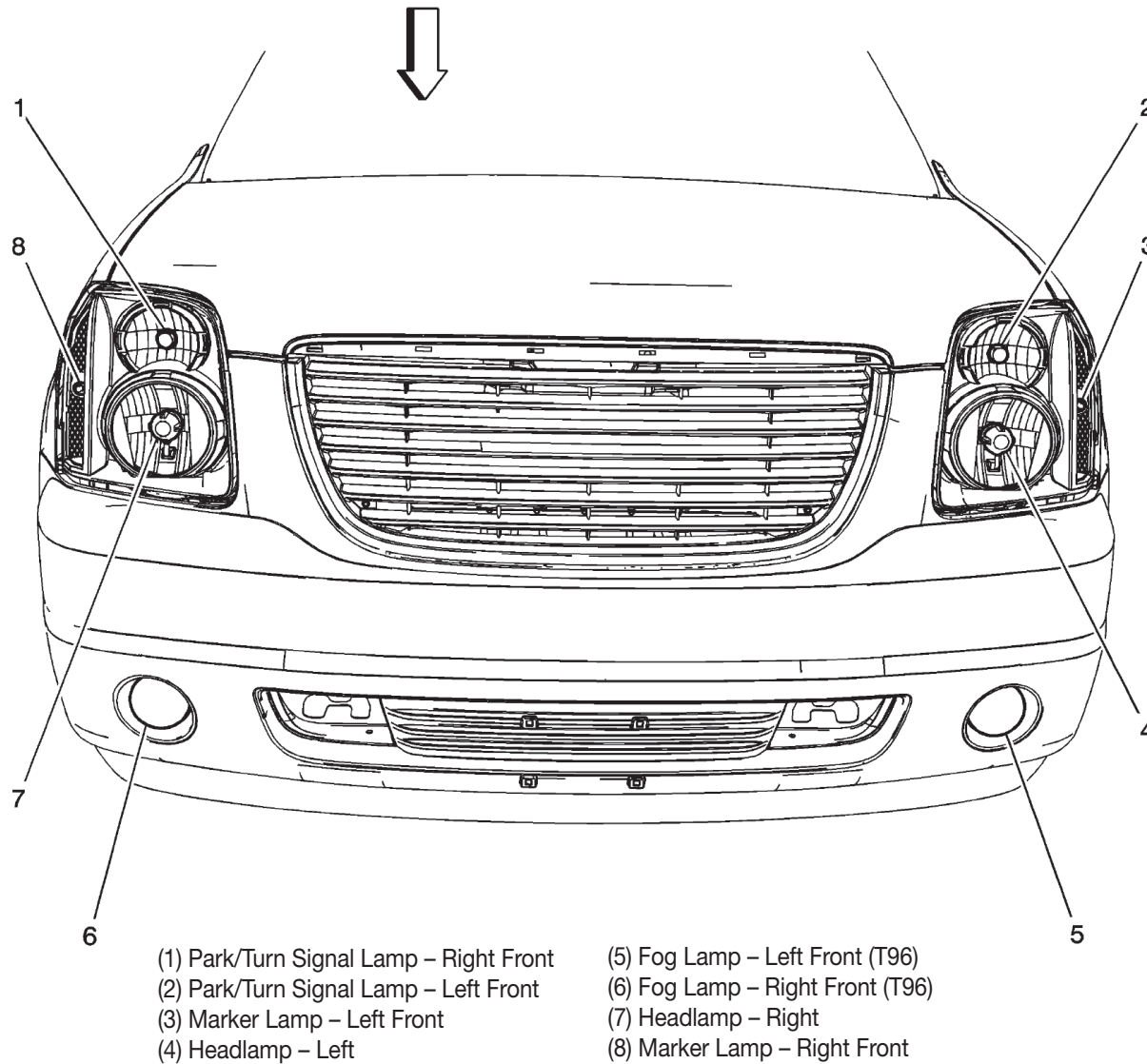

Forward Lighting & Additional Turn Signals – GMC Yukon (Z88)

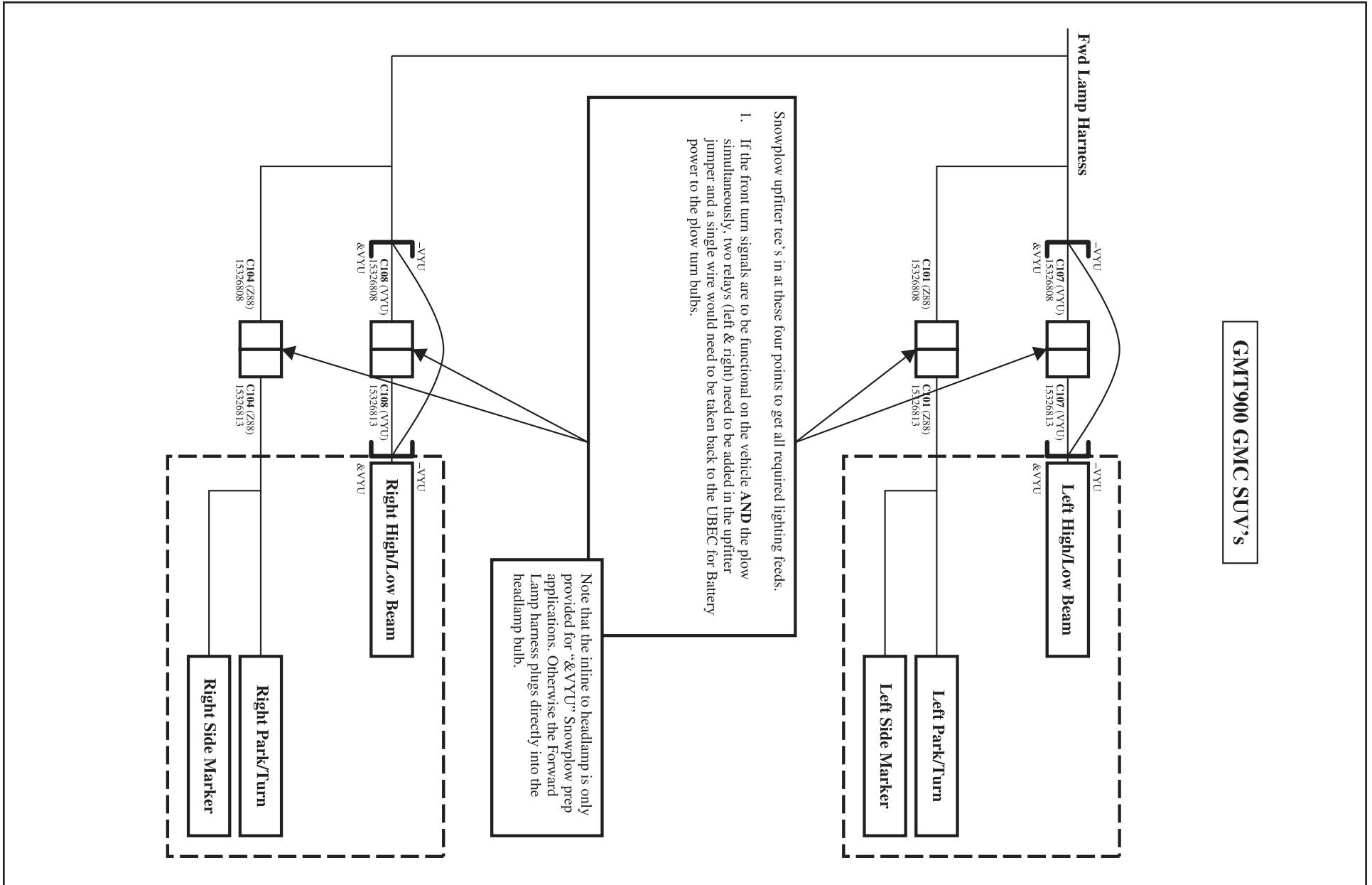

Front Fascia Harnesses GMC Yukon (Z88)

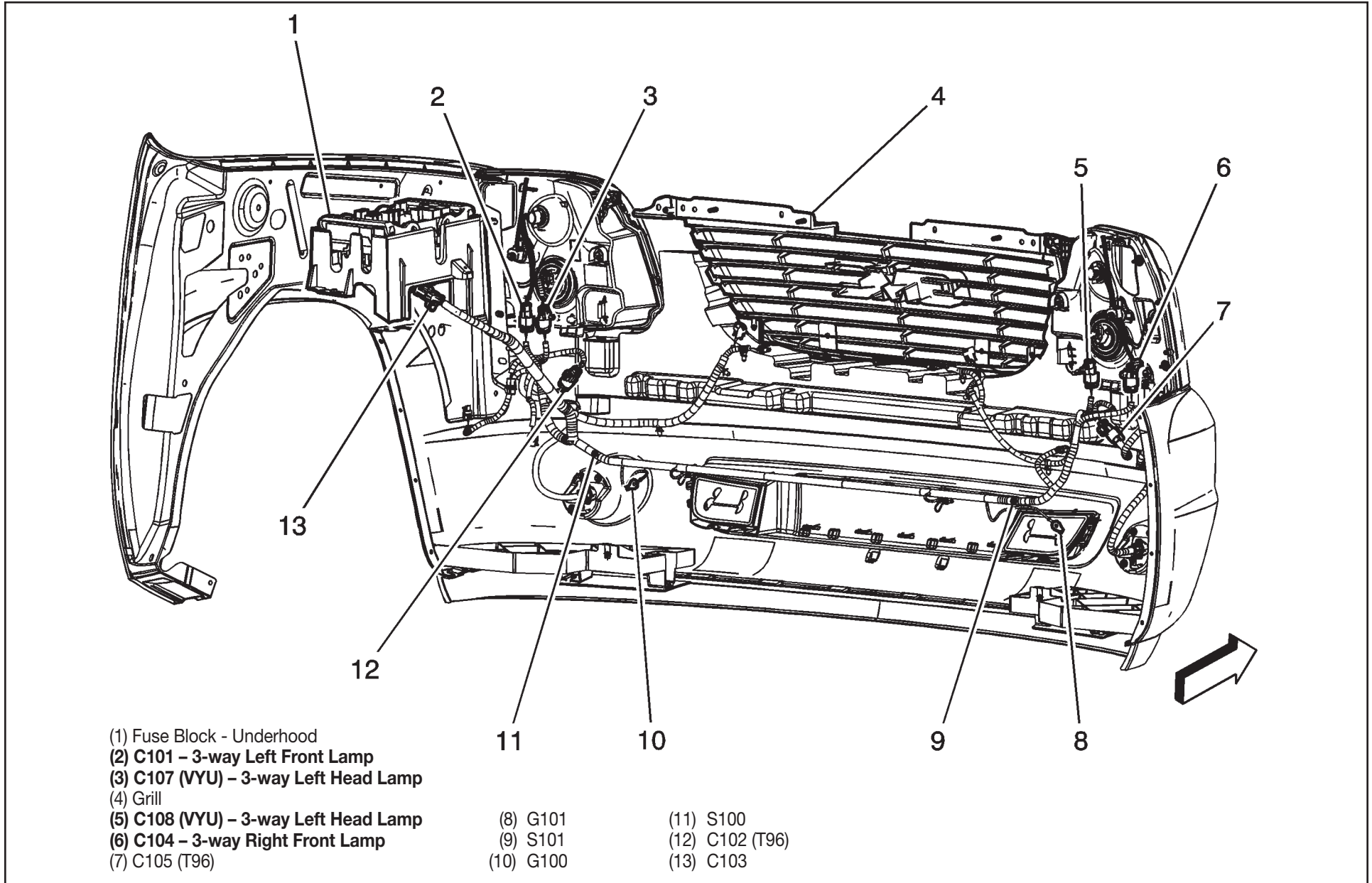

X104 Forward Lamp Harness to Right Front Lamp Harness (Z88)

Connector: 3-Way F GT 150 Series, Sealed (BK)
 O.E.M.: 15326808
 Color: **BLK**
 Service: See Catalog
 Terminal/Tray: 12191819/8
 Core/Insulation Crimp: Pins: A-B: 2/A
 Core/Insulation Crimp: Pins: C: E/A
 Release Tool/Test Probe: 15315247/J-35616-2A (GY)

Pin	Wire Color	Circuit No.	Function
A	BK	250	Ground
B	D-BU/WH	1315	Right Front Turn Signal Lamp Supply Voltage
C	BN	2609	Right Rear Park Lamps Supply Voltage

Connector: 3-Way M GT 150 Series, Sealed (BK)
 O.E.M.: 15326813
 Color: **BLK**
 Service: 15306377
 Terminal: TBD
 Core/Insulation Crimp: TBD
 Core/Insulation Crimp: TBD
 Release Tool/Test Probe: TBD

Pin	Wire Color	Circuit No.	Function
A	BK	--	Ground
B	D-BU/WH	--	Right Front Turn Signal Lamp Supply Voltage
C	BN	--	Right Rear Park Lamps Supply Voltage

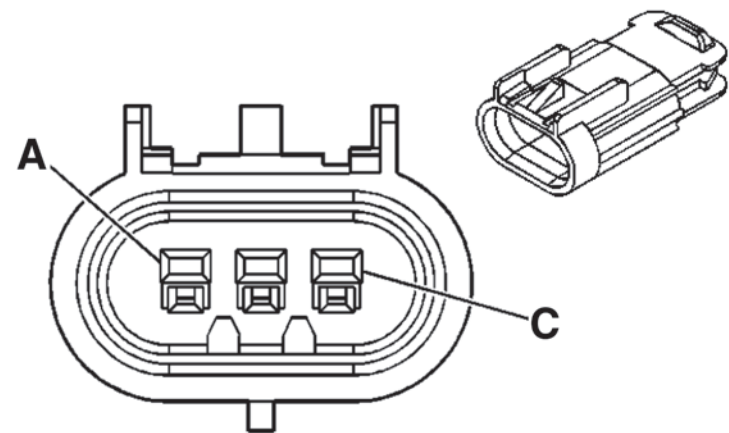
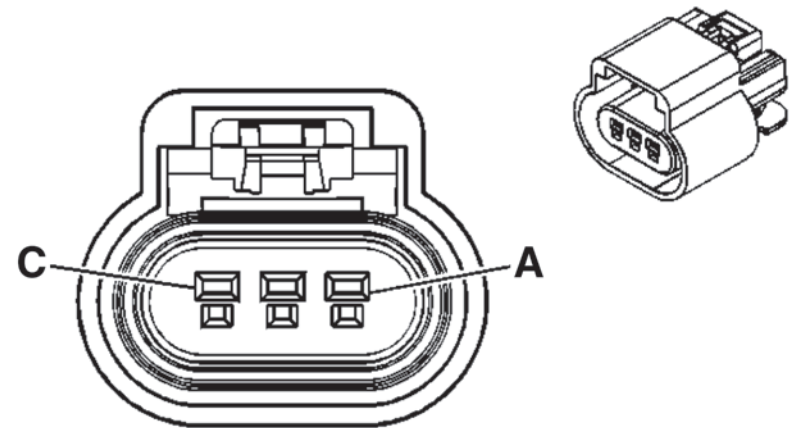

X107 Forward Lamp Harness to Forward Lamp Harness (VYU)

Connector: 3-Way F GT 150 Series, Sealed (BK)
 O.E.M.: 15326808
 Color: **BLK**
 Service: See Catalog

Pin	Wire Color	Circuit No.	Function
A	YE	712	Left Headlamp Low Beam Supply Voltage
B	BK	250	Ground
C	D-GN/WH	711	Left Headlamp High Beam Supply Voltage

Connector: 3-Way M GT 150 Series, Sealed (BK)
 O.E.M.: 15326813
 Color: **BLK**
 Service: 15306377

Pin	Wire Color	Circuit No.	Function
A	YE	712	Left Headlamp Low Beam Supply Voltage
B	BK	150	Ground
C	D-GN/WH	711	Left Headlamp High Beam Supply Voltage

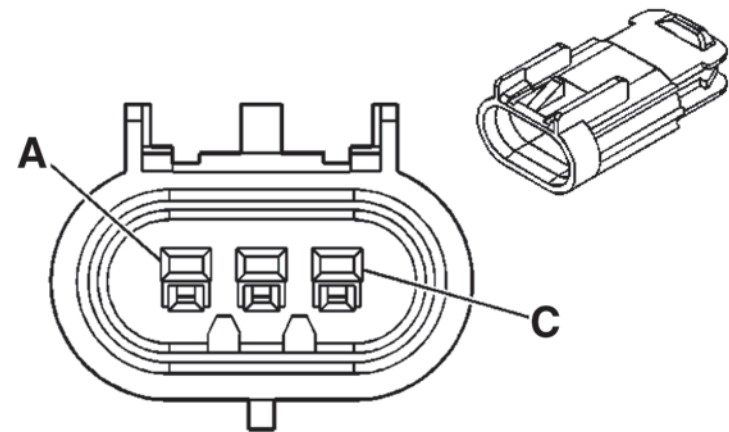
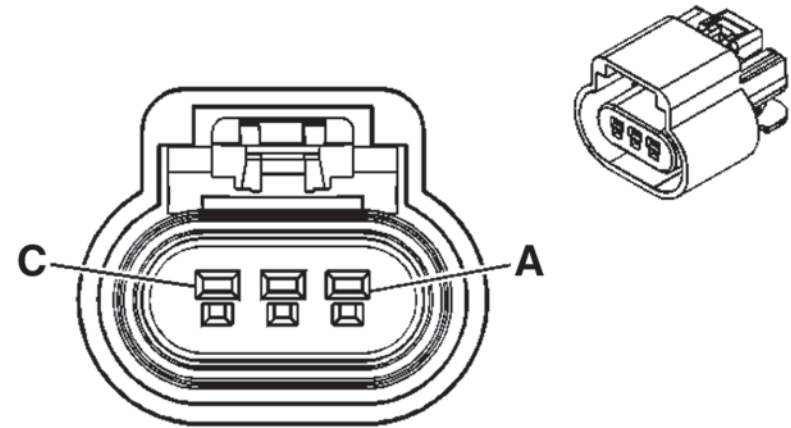

X108 Forward Lamp Harness to Forward Lamp Harness (VYU)

Connector: 3-Way F GT 150 Series, Sealed (BK)
 O.E.M.: 15326808
 Color: **BLK**
 Service: See Catalog

Pin	Wire Color	Circuit No.	Function
A	TN/WH	312	Right Headlamp Low Beam Supply Voltage
B	BK	150	Ground
C	L-GN/BK	311	Right Headlamp High Beam Supply Voltage

Connector: 3-Way M GT 150 Series, Sealed (BK)
 O.E.M.: 15326813
 Color: **BLK**
 Service: 15306377

Pin	Wire Color	Circuit No.	Function
A	TN/WH	312	Right Headlamp Low Beam Supply Voltage
B	BK	250	Ground
C	L-GN/BK	311	Right Headlamp High Beam Supply Voltage

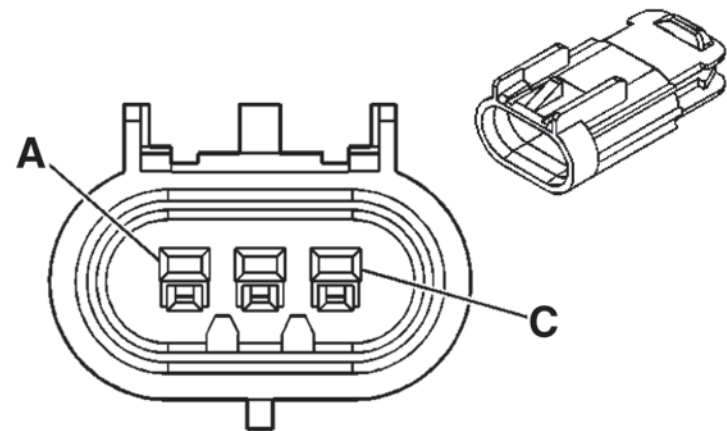
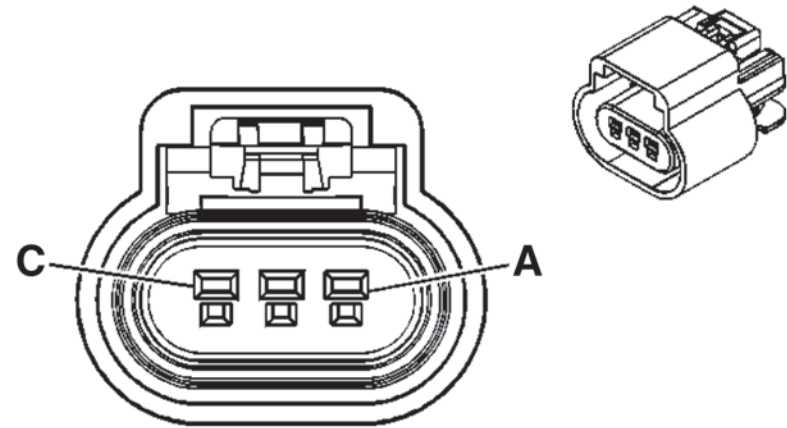

Headlamp Replacement – GMC Yukon SUV (Z88)

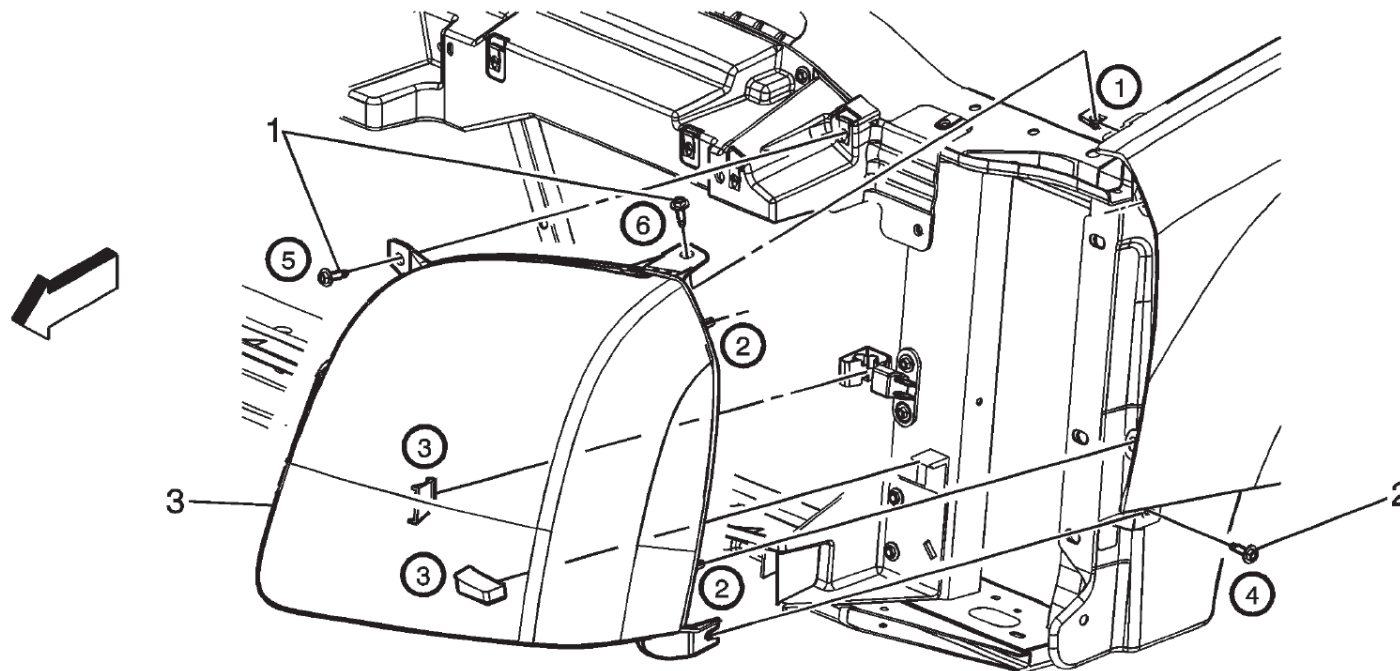

Callout	Component Name
Preliminary Procedures	
1	Remove the 2 forward wheelhouse liner screws.
2	Remove the 2 washer container push pins.
3	Open the hood.
4	Remove the 6 upper fascia bolts right to the hood latch mechanism.
5	Remove the lower rear fascia bolt from the support bracket.
6	Loosen the 2 fascia to fender bolts from under the fascia.
7	Pull the outboard end of the front fascia straight outboard until it disengages from the fender attachment bracket.

Callout	Component Name
Preliminary Procedures	
8	Pull the fascia forward and downward to allow enough clearance to remove the headlamp assembly.
9	Loosen the lower outboard attachment bolts.
10	Remove the 2 upper headlamp bolts.
11	Grasp the headlamp at the upper inboard and lower outboard side and pull the headlamp forward to disengage the locating tab.
12	Pull the outboard side of the headlamp forward until the 2 locating pins disengage from the radiator support.
13	Disconnect the forward lamp harness connector.

Headlamp Bulb Replacement – GMC Yukon SUV (Z88)

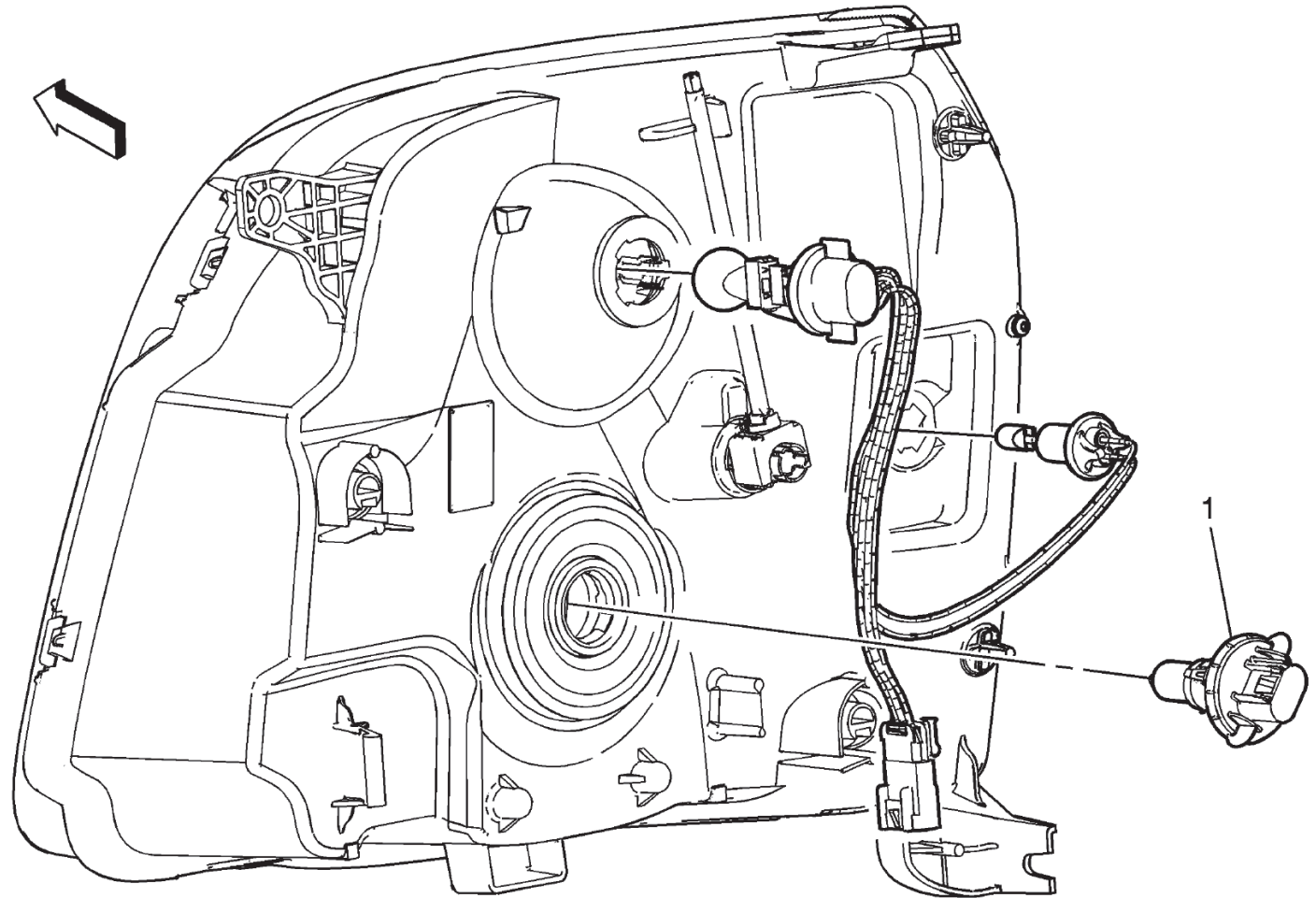

Callout	Component Name
Preliminary Procedure Remove the headlamp. Refer to Headlamp Replacement	
1	High Low Beam Bulb

Front Lights – Chevrolet Silverado Pickup (X88)

- (1) Park/Turn Signal Lamp – Right Front Upper
- (2) Headlamp – Low Beam – Right
- (3) Headlamp – Low Beam – Left
- (4) Park/Turn Signal Lamp – Left Front Upper
- (5) Park/Turn Signal Lamp – Right Front Lower
- (6) Headlamp – High Beam – Left
- (7) Fog Lamp – Left Front (T96)
- (8) Fog Lamp – Right Front (T96)
- (9) Headlamp – High Beam – Right
- (10) Park/Turn Signal Lamp – Right Front Lower

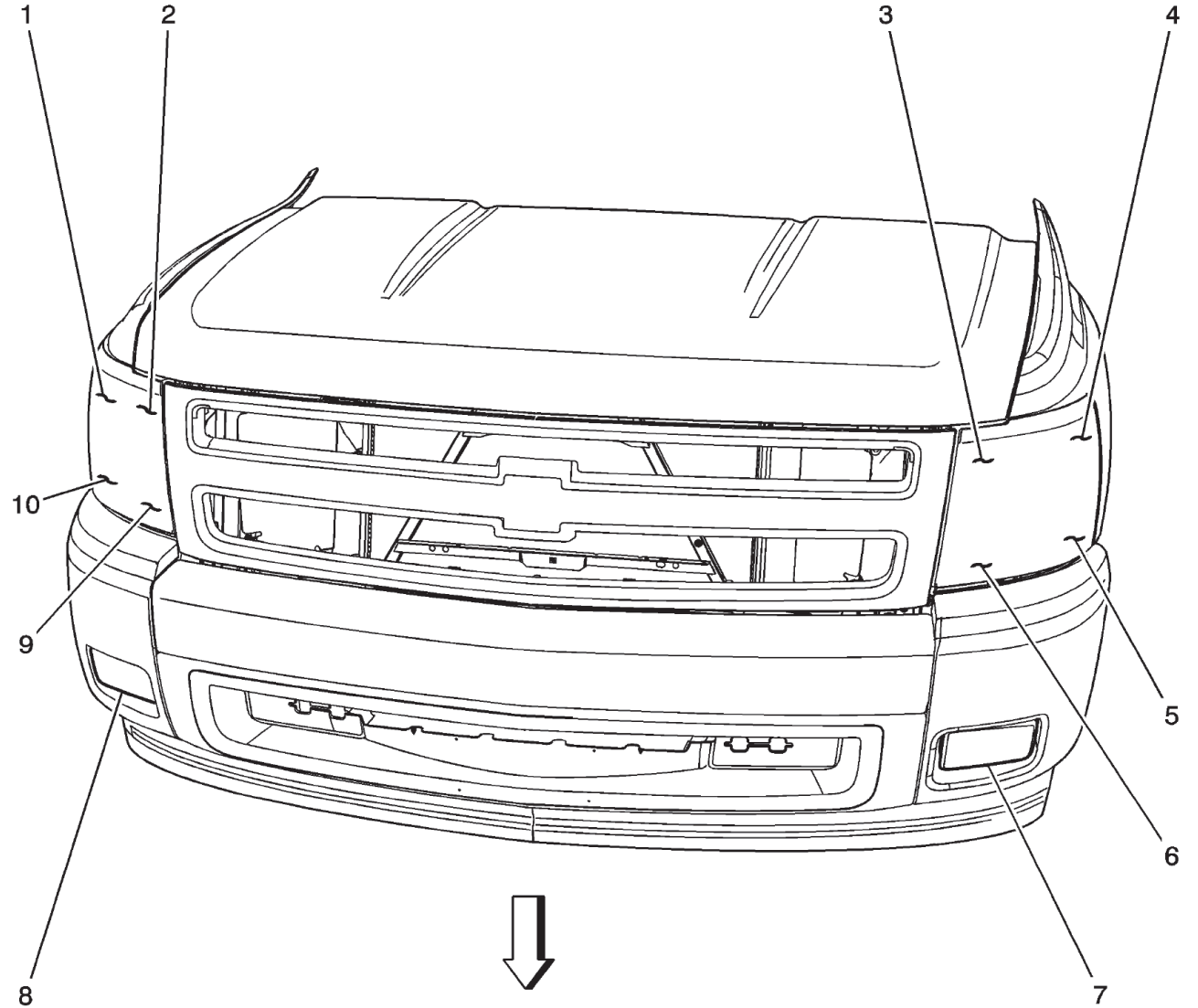

Front Lights – GMC Sierra Pickup (Z88)

- (1) Headlamp – Low Beam – Right
- (2) Park/Turn Signal Lamp – Right Front Upper
- (3) Park/Turn Signal Lamp – Left Front Upper
- (4) Headlamp – Low Beam – Left
- (5) Marker Lamp – Left Front
- (6) Headlamp – High Beam – Left
- (7) Park/Turn Signal Lamp – Left Front Lower
- (8) Fog Lamp – Left Front (T96)
- (9) Fog Lamp – Right Front (T96)
- (10) Park/Turn Signal Lamp – Right Front Lower
- (11) Headlamp – High Beam – Right
- (12) Marker Lamp – Right Front

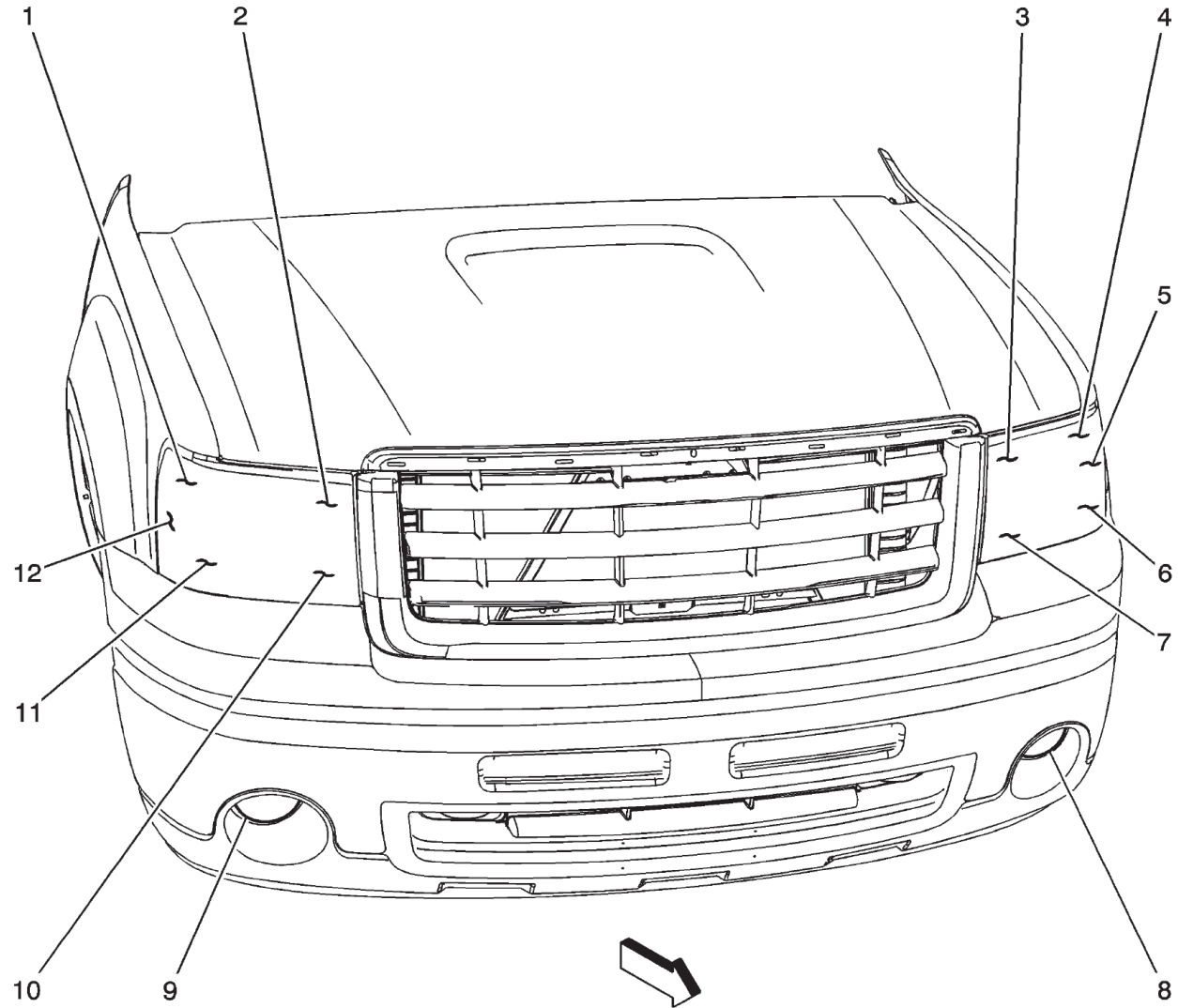

Forward Lighting & Additional Turn Signals – Chevrolet Silverado/GMC Sierra Pickups

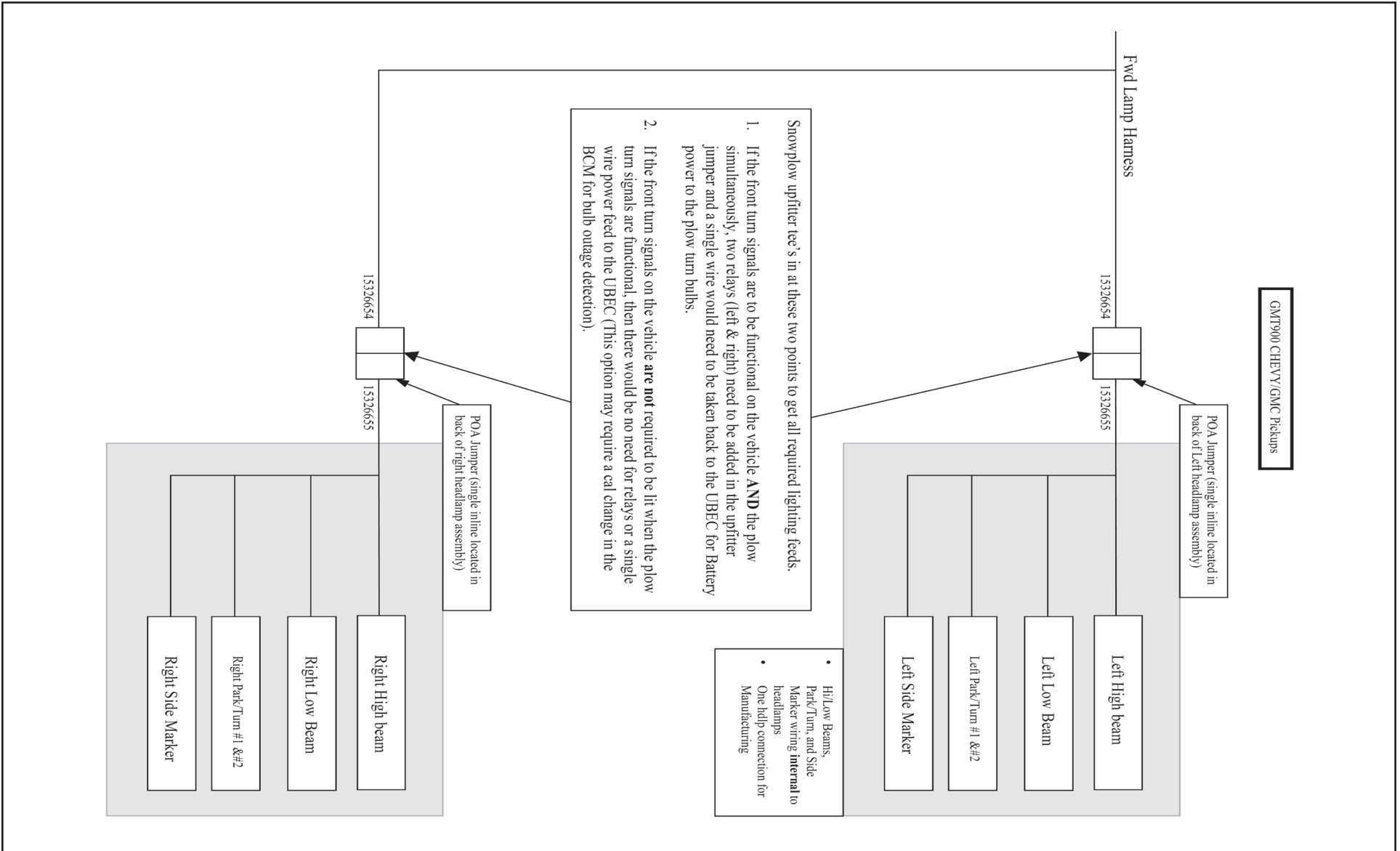

Forward Lamp Harness – Diesel – Chevrolet Silverado/GMC Sierra Pickups

- (1) G101
- (2) Left Front Fender
- (3) Left Front Headlamp
- (4) G100
- (5) Radiator
- (6) X-106**
- (7) J101
- (8) J100
- (9) X103**
- (10) X100
- (11) Fuse Block – Underhood X1

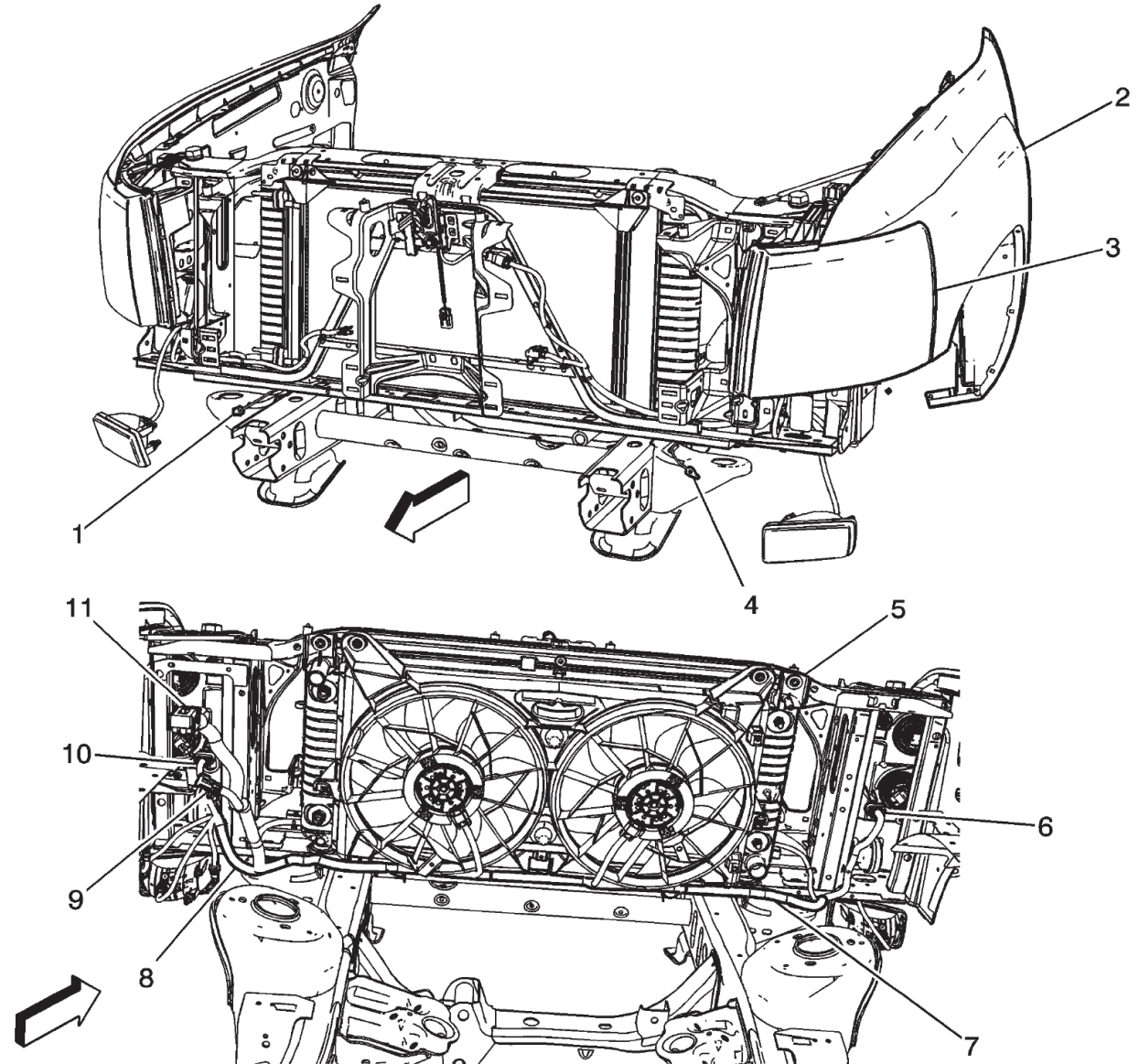

X100 Forward Lamp Harness to Left Headlamp Harness

Connector: 8-Way F GT 280 Series, Sealed (BK)
 O.E.M.: 15326654
 Color: **BLK**
 Service: 88986254

Pin	Wire Color	Circuit No.	Function
A	YE	712	Left Headlamp Low Beam Supply Voltage
B	BK	150	Ground
C	D-GN/WH	711	Left Headlamp High Beam Supply Voltage
D	---	---	Not Used
E	BN	2509	Left Rear Park Lamps Supply Voltage
F	BK	250	Ground
G	L-BU/WH	1314	Left Front Turn Signal Lamp Supply Voltage (X88)
H	---	---	Not Used

Connector: 8-Way M GT 280 Series, Sealed (BK)
 O.E.M.: 15326655
 Color: **BLK**
 Service: 15306424

Pin	Wire Color	Circuit No.	Function
A	YE	---	Left Headlamp Low Beam Supply Voltage
B	BK	---	Ground
C	D-GN/WH	---	Left Headlamp High Beam Supply Voltage
D	---	---	Not Used
E	BN	---	Left Rear Park Lamps Supply Voltage
F	BK	---	Ground
	BK	---	Ground
G	L-BU/WH	---	Left Front Turn Signal Lamp Supply Voltage (X88)
H	---	---	Not Used

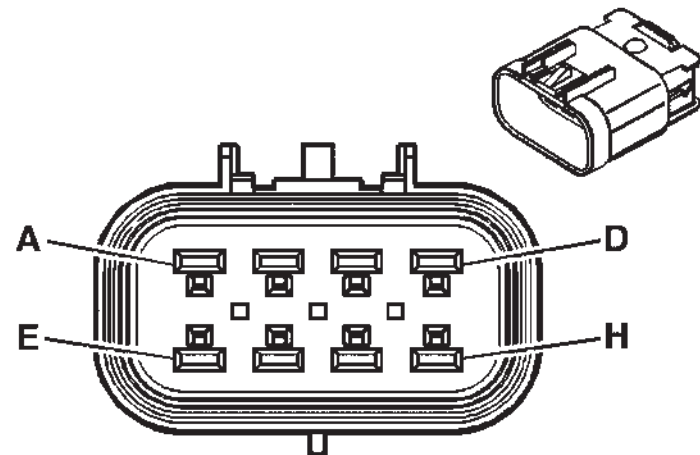
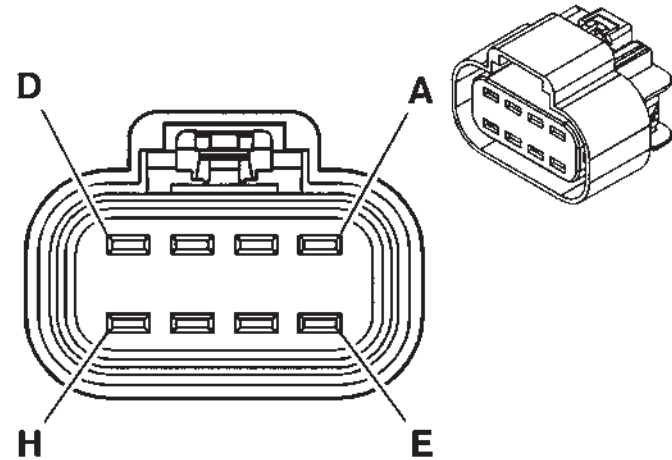

X106 Forward Lamp Harness to Right Headlamp Harness

Connector: 8-Way F GT 280 Series, Sealed (BK)
 O.E.M.: 15326654
 Color: **BLK**
 Service: 88986254

Pin	Wire Color	Circuit No.	Function
A	TN/WH	312	Right Headlamp Low Beam Supply Voltage
B	BK	250	Ground
C	L-GN/BK	311	Right Headlamp High Beam Supply Voltage
D	--	--	Not Used
E	BN	2609	Right Rear Park Lamps Supply Voltage
F	BK	150	Ground
	BK	250	Ground
G	D-BU/WH	1315	Right Front Turn Signal Lamp Supply Voltage
H	--	--	Not Used

Connector: 8-Way M GT 280 Series, Sealed (BK)
 O.E.M.: 15326655
 Color: **BLK**
 Service: 15306424

Pin	Wire Color	Circuit No.	Function
A	TN/WH	--	Right Headlamp Low Beam Supply Voltage
B	BK	--	Ground
C	L-GN/BK	--	Right Headlamp High Beam Supply Voltage
D	--	--	Not Used
E	BN	--	Right Rear Park Lamps Supply Voltage
F	BK	--	Ground
	BK	--	Ground
G	D-BU/WH	--	Right Front Turn Signal Lamp Supply Voltage
H	--	--	Not Used

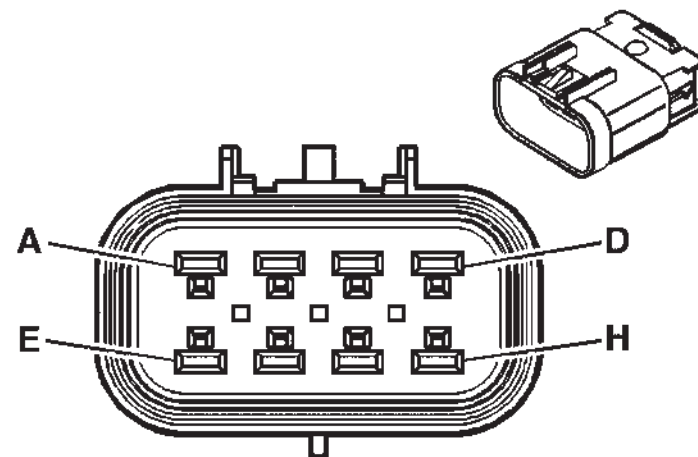
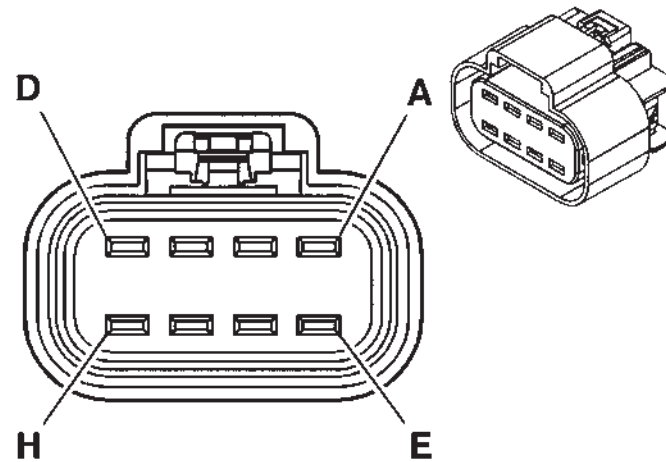

Headlamp Replacement – Chevrolet Silverado/GMC Sierra Pickups

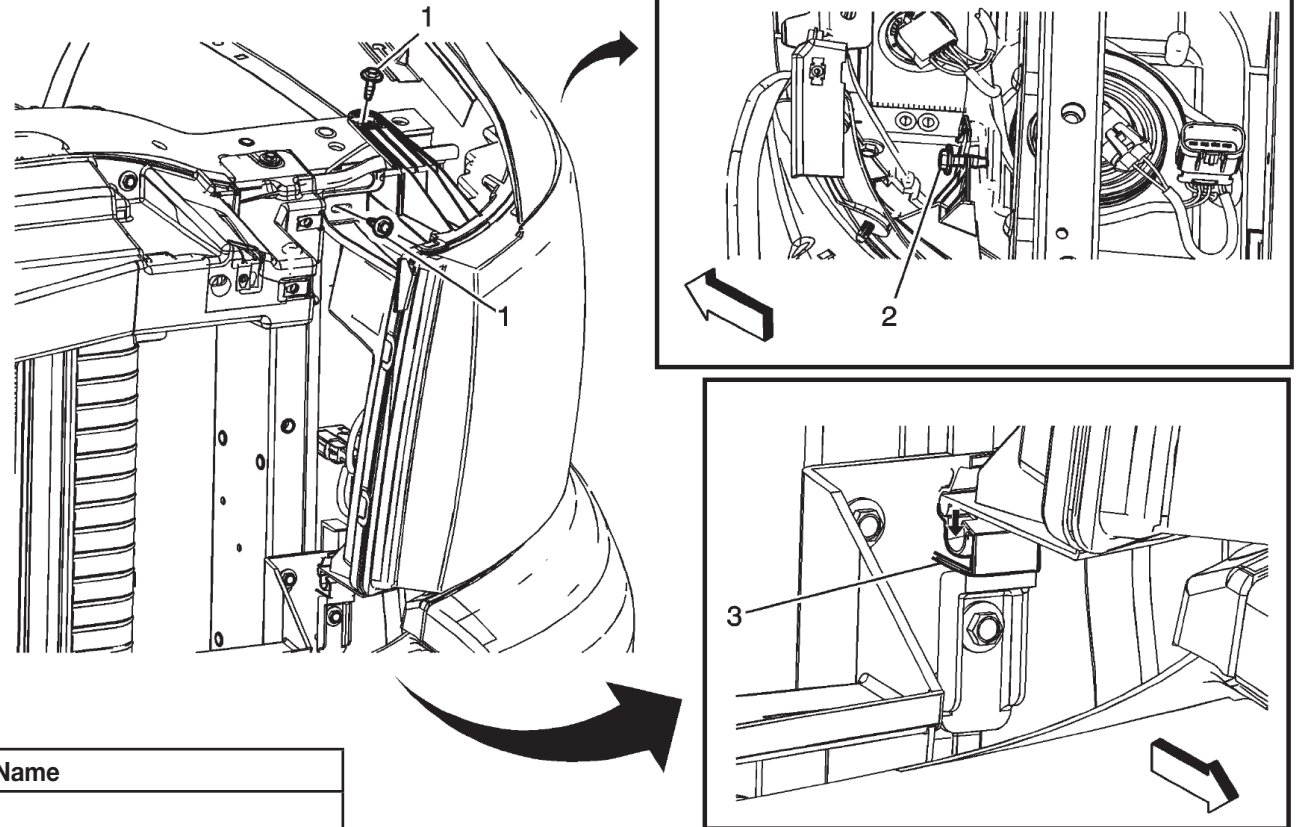

Callout	Component Name
Preliminary Procedures	
1	Remove the front bumper fascia trim cap. Refer to Front Bumper Fascia Trim Cap Replacement .
2	Disengage the front portion of either the LF or RF wheelhouse liner in order to access the lower inside hidden headlamp bolt. Refer to either Front Wheelhouse Liner Replacement – Left Side for the left side or Front Wheelhouse Liner Replacement – Right Side for the right side wheelhouse liner.
3	Loosen only, do not remove, the lower outside hidden headlamp bolt (2).

Headlamp Bulb Replacement – GMC Yukon (Z88)

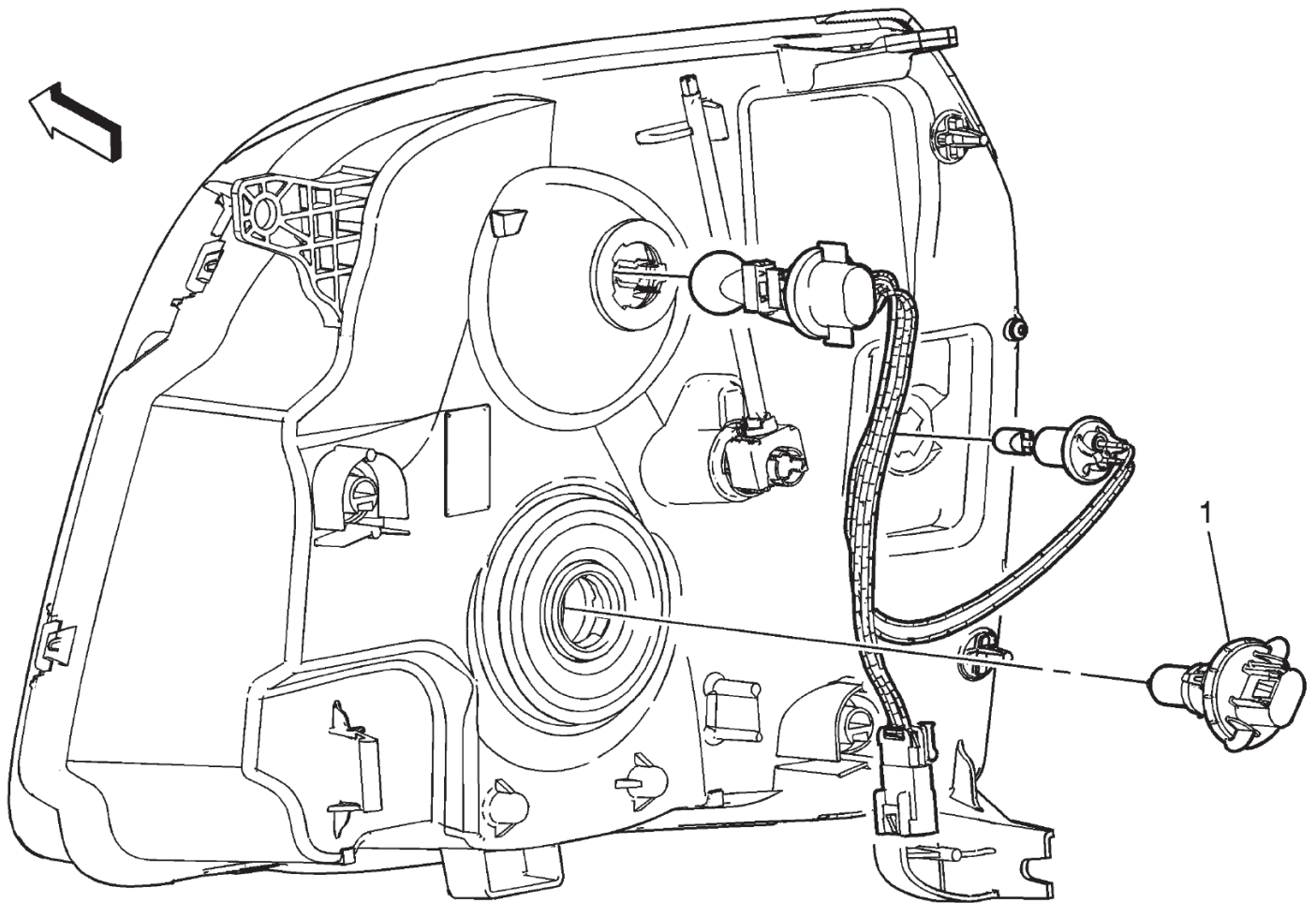

Callout	Component Name
Preliminary Procedure Remove the headlamp. Refer to Headlamp Replacement	
1	High Low Beam Bulb

Replacement Bulbs

Replacement Bulbs – 2008 Chevrolet Silverado

Exterior Lamp	Bulb Number
Backup Lamp	3047
Backup Lamp*	1156
Cargo lamp and Center High-Mounted Stoplamp (CHMSL)	912
Daytime Running Lamps	4114K
Fender Marker Lamp	W5WLL
High-Beam Headlamp	9005
Low-Beam Headlamp	H11
License Plate Lamp	168
Sidemarkers Lamp/Stoplamp/Taillamp/Turn Signal Lamp	3047
Stoplamp/Turn Signal Lamp/Taillamp*	1157

*Chassis Cab Models

Replacement Bulbs – 2008 Chevrolet Tahoe

Exterior Lamp	Bulb Number
Backup Lamp	3047
Center High-Mounted Stoplamp (CHMSL), Cargo Lamp	912
Front Turn Signal Lamp, Sidemarkers Lamp and Parking Lamp	3157A
High-Beam Headlamp	9005
Low-Beam Headlamp	H11
License Plate Lamp	168
Rear Turn Signal Lamp, Taillamp, and Stoplamp	3047
Sidemarkers Lamp	194

Replacement Bulbs – 2008 GMC Yukon

Exterior Lamp	Bulb Number
Backup Lamp	7441
High-Beam Headlamp	H13
Low-Beam Headlamp	H13
License Plate Lamp	168
Rear Turn Signal Lamp, Taillamp, and Stoplamp	3057KX

Trailer Lighting Schematic

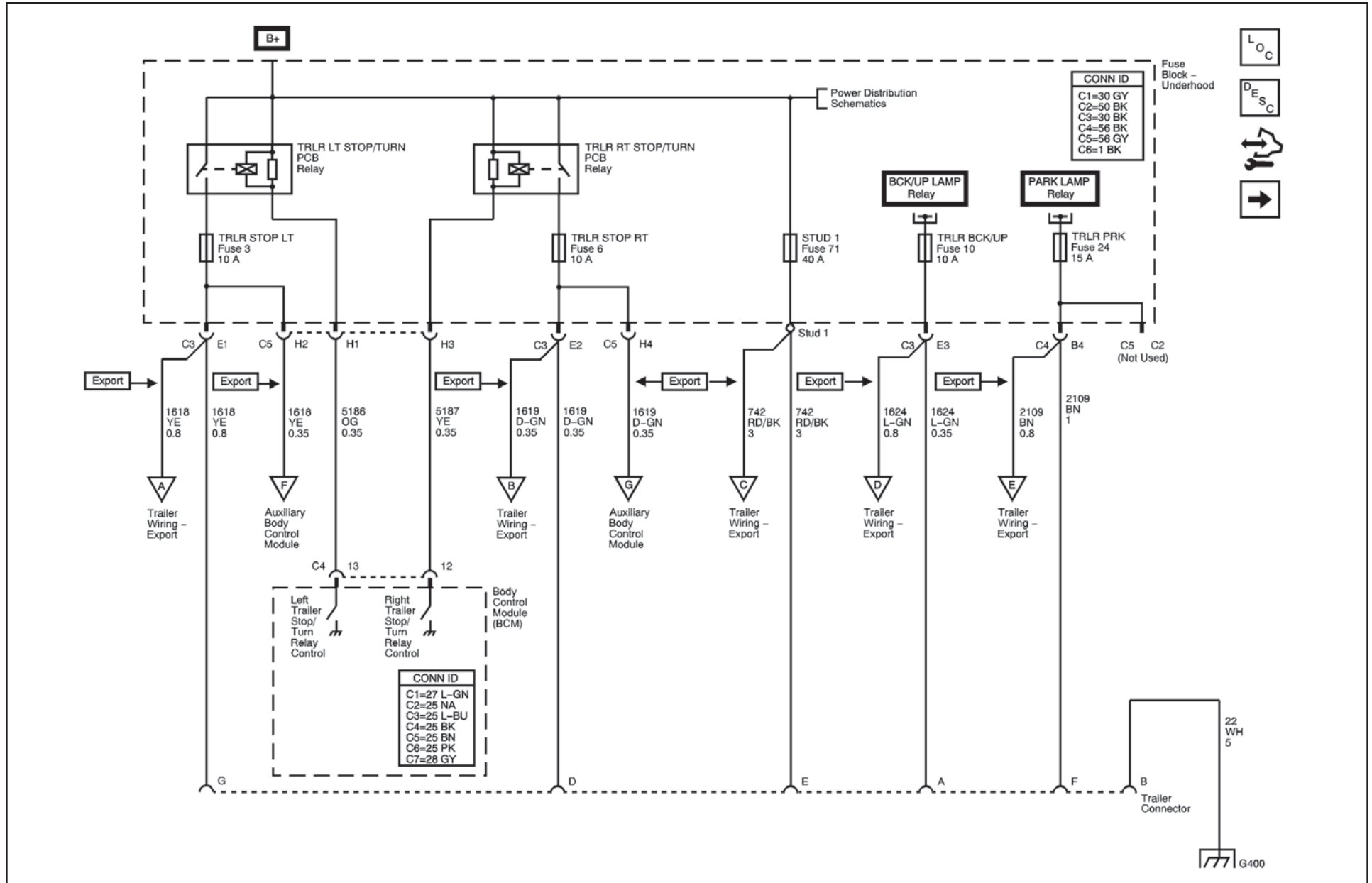

Trailer Connector

Connector Part Information

OEM: 15354653

Service: 15306164

Description: 7-Way F Metri-Pack 280 630 Series Sealed

Pins: B

Terminal/Tray: 12052456/3

Core/Insulation Crimp: TBD

Release Tool/Test Probe: TBD

Pins: A, D, F, G

Terminal/Tray: 12110847/4

Core/Insulation Crimp: C/5

Release Tool/Test Probe: 15315247/J-35616-4A (PU)

Pins: C, E

Terminal/Tray: 12110845/4

Core/Insulation Crimp: F/5

Release Tool/Test Probe: 15315247/J-35616-4A (PU)

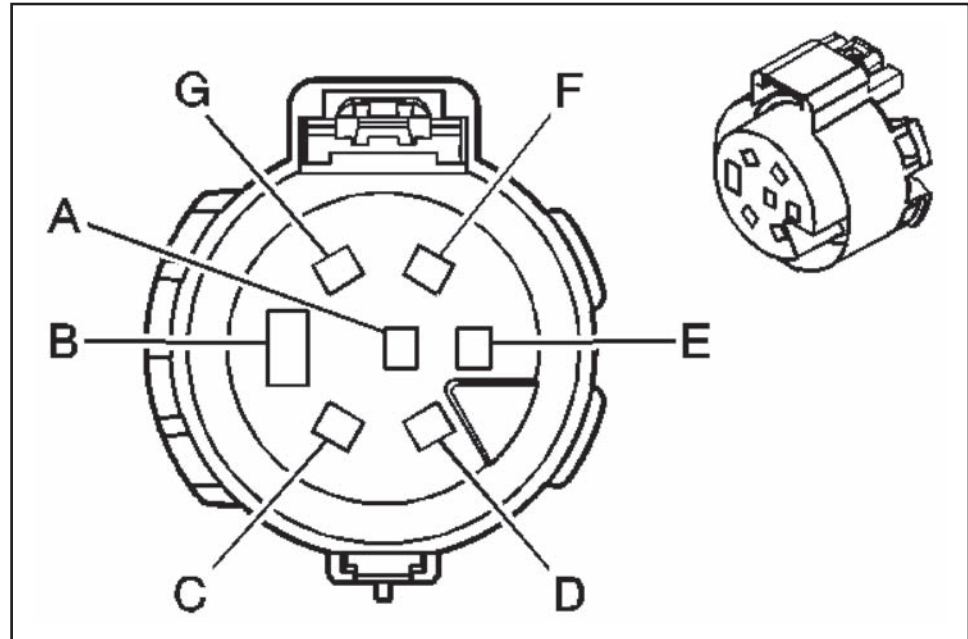

Trailer Connector			
Pin	Wire Color	Circuit No.	Function
A	L-GN	1624	Trailer Backup Lamp Supply Voltage
B	WH	22	Ground
C	D-BU	47	Trailer Auxiliary Supply Voltage
D	D-GN	1619	Trailer Right Rear Turn/Stop Lamp Supply Voltage
E	RD/BK	742	Battery Positive Voltage
F	BN	2109	Trailer Park Lamp Supply Voltage
G	YE	1618	Trailer Left Rear Turn/Stop Lamp Supply Voltage

Wiring Location

- (1) Rear Bumper
- (2) Junction Block – Rear Lamps
- (3) Terminator Resistor
- (4) Trailer Connector (UY7)

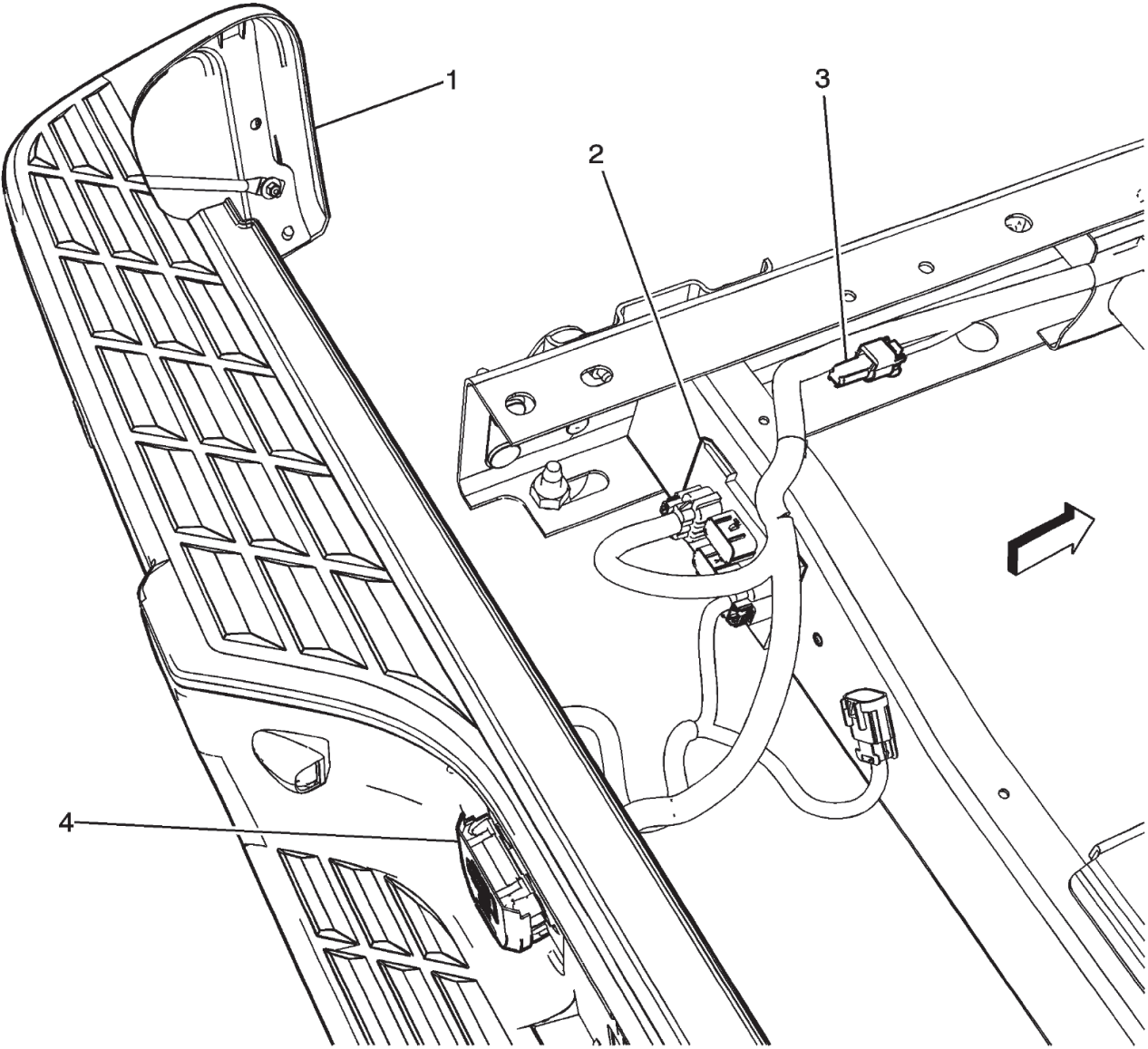

Trailer/Camper Connector Wiring (1 of 2)

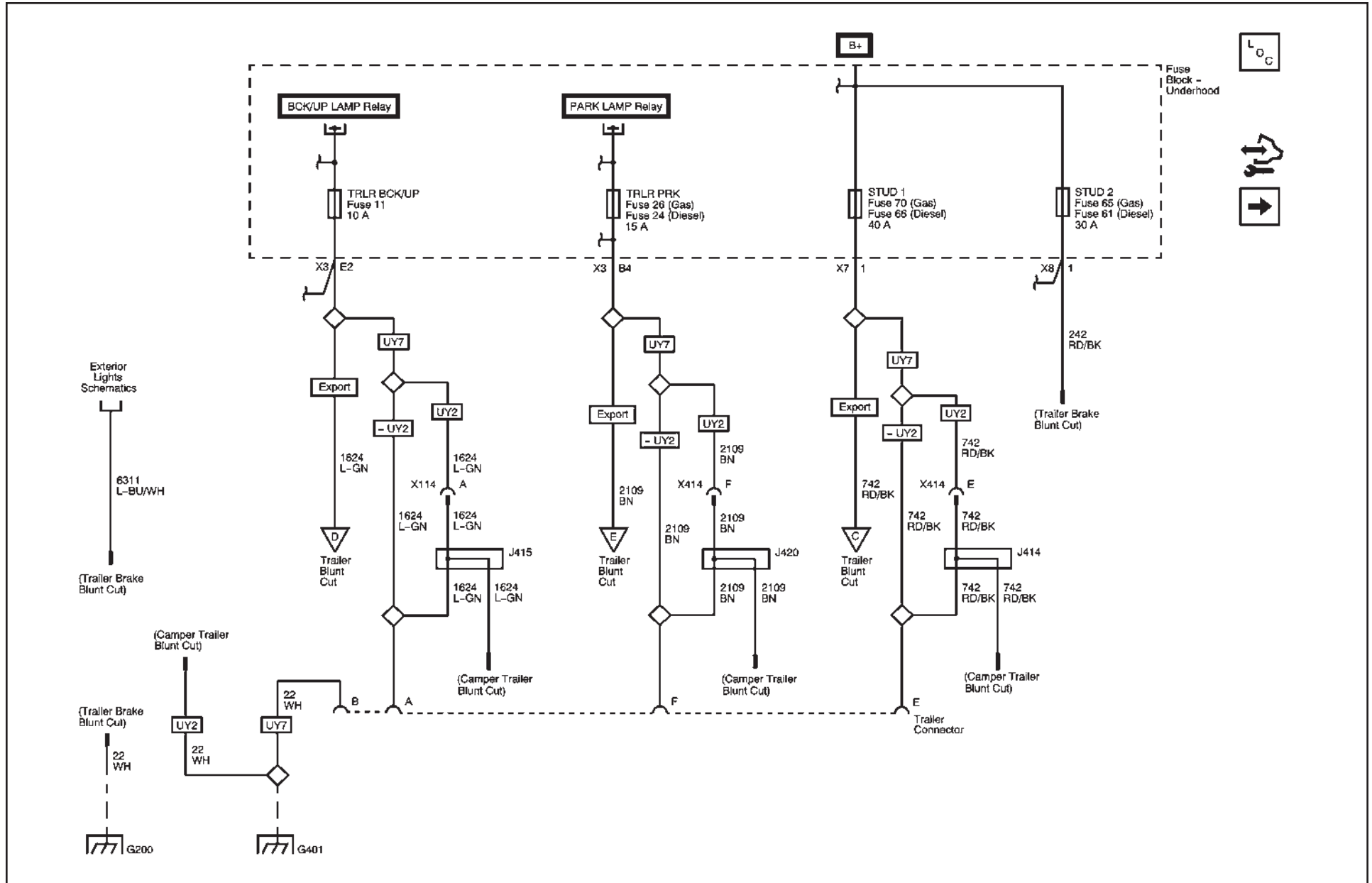

Trailer/Camper Connector Wiring (2 of 2)

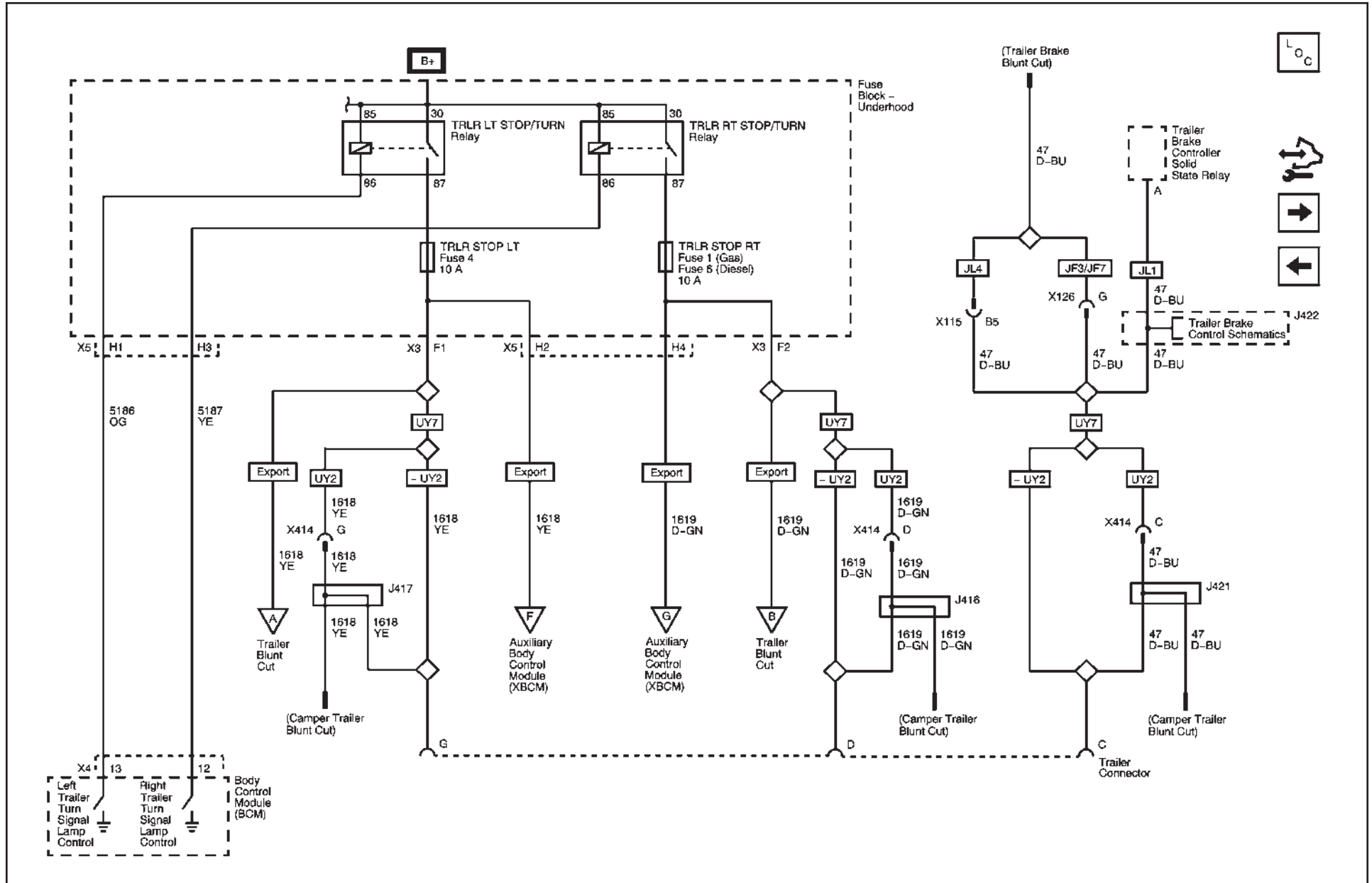

Trailer/Camper Wiring Location

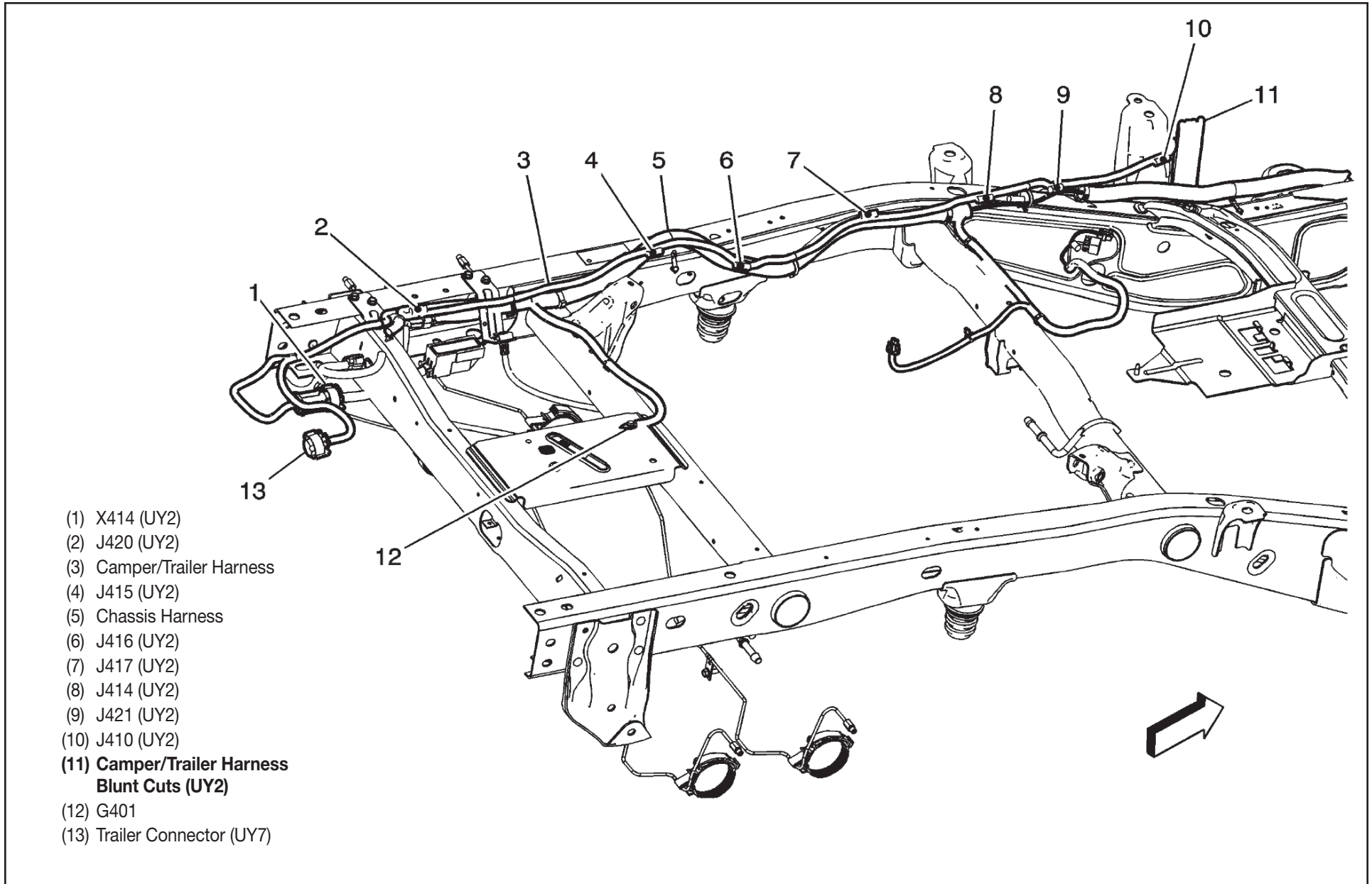

Electric Trailer Brake Controller (ITBC) Wiring and Auxiliary 12-V Feed to Trailer

Applies to the following 2008 Full-Size Utilities and Pickups:

- 2008 Cadillac Escalade, Escalade ESV, Escalade EXT
- 2008 Chevrolet Avalanche, Silverado, Suburban, Tahoe
- 2008 GMC Sierra, Yukon, Yukon Denali, Yukon XL, Yukon Denali XL

The Following Step-by-Step Explanations Describe Installation of an Electric Trailer Brake Controller and Auxiliary 12-Volt Feed to Trailer

Starting with new 2008 full size utilities and pickups, a separate electric trailer brake controller pigtail harness is no longer provided. The trailer brake controller wiring is now part of the Instrument Panel (IP) wiring harness, and the blunt cut wires are located under the left side of the IP, behind the DataLink connector.

Note: *These instructions do not apply to vehicles with Option JL1 (Integrated Trailer Brake Controls) available on 2008 H.D. trucks; or trucks with Option TP2 (H.D. availability) that already have the 12V battery Trailer Feed used as part of the RPO.*

The explanation on Pages A-4 and A-5 shows how to locate the correct portion of the IP wiring harness and install a typical Trailer Brake Controller in a 2008 Chevrolet Silverado or GMC Sierra Pickup.

The explanation and photos on Page A-7 show how to install an Auxiliary 12V Feed to the Trailer in the same vehicles.

Installing Electric Trailer Brake Controller Wiring



1. Locate the trailer brake control circuits looped and taped to the main harness under the IP (Fig. 1)



2. Pull the trairling harness wire down (Fig. 2)

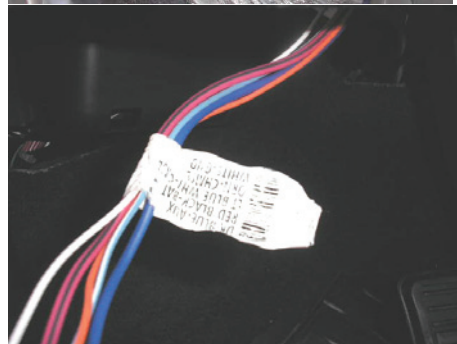

3. Match vehicle harness label circuit functions to the trailer brake controller jumper harness functions (Fig. 3)

Figure 3

NOTE

The vehicle owner's manual (page 483) refers to 4 wires, but there are 5 wires looped back in the IP harness. The fifth wire is not required with most systems (see table below).

Match functions: The color of wires that are joined together may not match.

Wire Color	Circuit #	Function
Dark Blue	47	Switched power from controller to trailer brakes
Red with Black Stripe	242	Fused vehicle power to electrical brake controller - 12-volt (30A stud #2)
Light Blue with White Stripe	6311	Brake switch input to power electric brake controller
White	22	Ground
Orange	--	CHMSL (not required with most systems)

(continued on next page)

Installing Electric Trailer Brake Controller Wiring (cont'd)



Figure 4

4. After completing the under-IP connections to the electric brake controller, open the hood and locate the red wire taped to the harness between the under-hood electrical center and the driver-side front fender (Fig. 4)

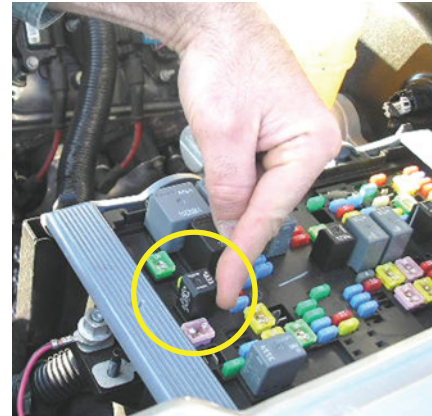

Figure 6

NOTE

The fuse for the trailer brake controller circuit is factory-installed on the under-hood electrical center (Fig. 6)

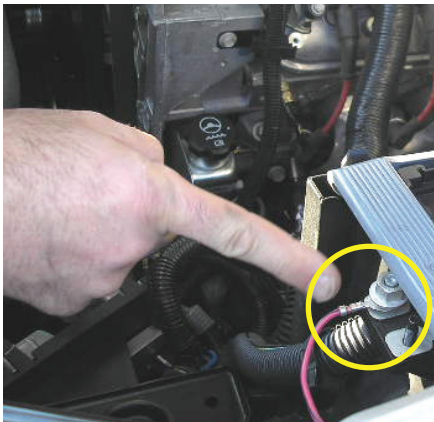
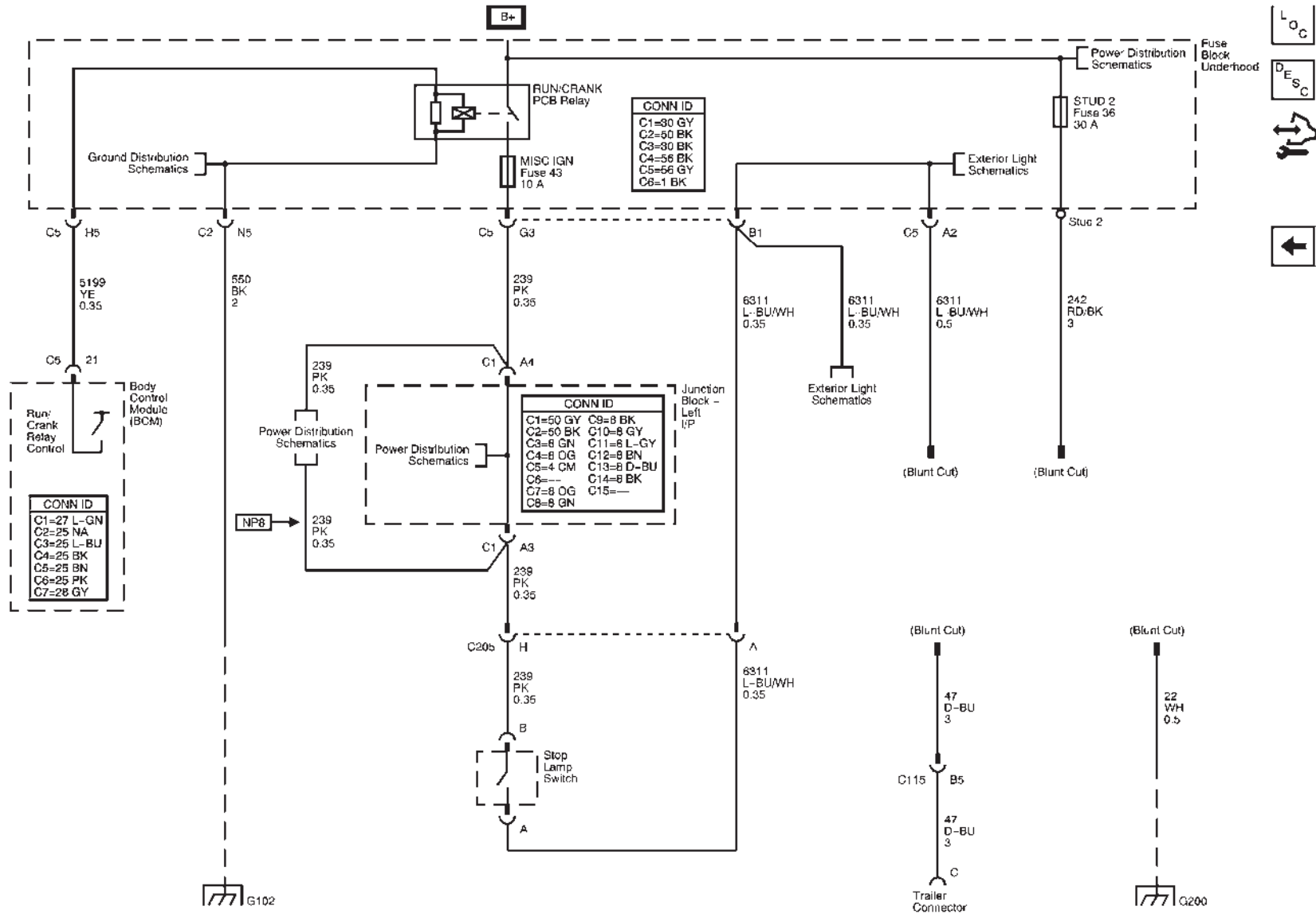

Figure 5

5. Break the tape on the red wire and pull the wire toward the front of the vehicle
6. Remove the cover from the under-hood electrical center
7. Place the terminal on the larger of the two studs at the front of the under-hood electrical center and secure with an M8 nut (Fig. 5)

Electric Trailer Brake Wiring

Electric Trailer Brake Wiring Schematic



Installing Auxiliary 12-Volt Feed to Trailer

NOTE

This hookup is used to provide power for 12-Volt DC electrical devices in the trailer (example: lights, refrigerator or battery charger).

Devices powered by this circuit will drain the vehicle's battery if left connected while the engine/alternator is not operating.

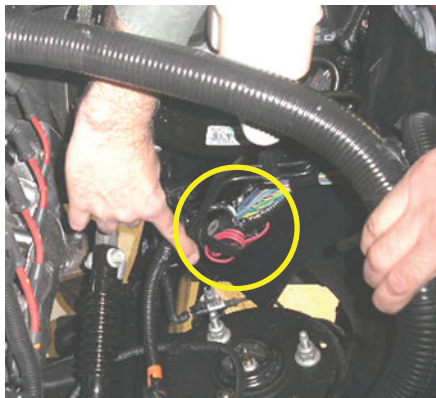

Figure 1

1. Locate the red wire looped and taped to the chassis harness below the brake master cylinder (Fig. 1)

2. Break the tape and route the wire to the front of the vehicle's under-hood electrical center

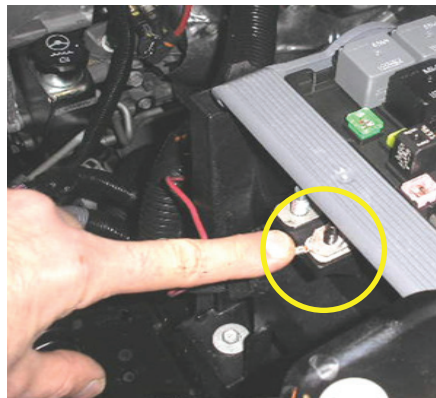

Figure 2

3. Place the terminal on the smaller of the two studs (Fig. 2) in front of the under-hood electrical center and secure with an M6 fastener

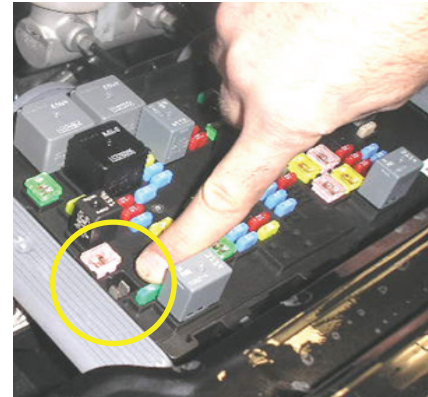

Figure 3

4. Install a 40-amp fuse to power the circuit (Fig. 3)

Integrated Trailer Brake Control (ITBC) Description & Operation – Option JL1

This vehicle may be equipped with a Trailer Brake Control (TBCM) system for electric trailer brakes. The power output to the trailer brakes is based on the amount of brake pressure being applied in the vehicles brake system. The available power output to the trailer brakes can be adjusted to a wide range of trailering situations.

Important: Connecting a trailer that is not compatible with the ITBC system may result in reduced or complete loss of trailer braking. There may be an increase in stopping distance or trailer instability which could result in personal injury or damage to your vehicle, trailer, or other property. An aftermarket controller may be available for use with trailers with surge, air or electric-over-hydraulic trailer brake systems. To determine the type of brakes on your trailer and the availability of controllers, check with your trailer manufacturer or dealer.

Important: If your vehicle is equipped with an ITBC, the blunt cuts exist, but are not connected further in the harness. If you install an aftermarket trailer brake controller, the ITBC must be disconnected. Do not power both ITBC and aftermarket controllers to control the trailer brakes at the same time.

The vehicle is equipped with the following trailer braking components:

- Manual Trailer Brake Apply
- Trailer Gain Adjustment
- Trailer Brake Control Panel
- Trailer Brake DIC Display

Manual Trailer Brake Apply

The Manual Trailer Brake Apply Lever is located on the Trailer Brake Control Panel, and is used to apply the trailer electric brakes independent of your vehicle brakes. This lever is used in the Trailer Gain Adjustment Procedure to properly adjust the power output to the trailer brakes. Sliding the lever to the left will apply only the trailer brakes. The power output to the trailer is indicated in the Trailer Brake Display Page in the DIC. If your vehicle service brakes are applied while using the Manual Trailer Brake Apply Lever, the trailer output power will be the greater of the two.

The trailer and the vehicle brake lamps will come on when either vehicle braking or manual trailer brakes are applied.

Trailer Gain Adjustment

Trailer Gain should be set for a specific trailering condition, and must be adjusted any time vehicle loading, trailer loading or road surface conditions change.

Setting the Trailer Gain properly is needed for the best trailer stopping performance. A trailer that is over-gained may result in locked trailer brakes. A trailer that is under-gained may result in not enough trailer braking. Both of these conditions may result in poorer stopping and stability of the vehicle and trailer.

(continued on next page)

Integrated Trailer Brake Control (ITBC) Description & Operation – Option JL1 (cont'd)

Trailer Gain Adjustment (cont'd)

After the electrical connection is made to a trailer equipped with electric brakes, the **TRAILER CONNECTED** message will be momentarily displayed on the DIC. The Trailer Brake Display Page will appear on the DIC showing **TRAILER GAIN** and **OUTPUT**, after all vehicle related service messages are acknowledged by the driver. The dashed lines in the **TRAILER OUTPUT** display signifies a disconnected trailer or TBCM fault condition, and will disappear only when the TBCM fault condition is not present.

Important: Trailer wheel lock-up may not occur if towing a heavily loaded trailer. In this case, adjust the trailer gain to the highest allowable setting for the towing condition.

- Adjust trailer gain in 0.5 step increments up to 10 gain setting by using the gain adjustment +/- buttons on the trailer brake control panel switch. Pressing and holding a gain button will cause the trailer gain to continuously increment or decrement. To turn the output to the trailer off, set the gain to zero.
- Drive the tow vehicle and trailer combination on a level road surface representative of the towing condition, and free of traffic at approximately 32-40 km/h (20-25 mph) and fully apply the manual trailer brake apply lever mechanism located on the trailer brake control panel switch. Adjusting trailer gain at slower speeds may result in an incorrect gain setting.
- Adjust the trailer gain to just below the threshold of trailer wheel lock-up.

Trailer Brake Control Panel

The TBCM system has a control panel with the trailer gain and manual apply switches, and is located on the instrument panel to the left of the steering column. See Instrument Panel Overview for more information on location. The control panel and switches allows you to adjust the amount of output, referred to as trailer gain, available to the electric trailer brakes and allows you to manually apply the trailer brakes. The Trailer Brake Control Panel, and switches is used along with the Trailer Brake Display Page on the DIC to adjust and display power output to the trailer brakes.

Driver Information Indicators and Messages

The following indicators are used to inform the driver of several different factors:

TRAILER CONNECTED

This message will be briefly displayed when a trailer with electric brakes is first connected to the vehicle. This message will automatically turn off in about ten seconds. The driver can also acknowledge this message before it automatically turns off.

(continued on next page)

Integrated Trailer Brake Control (ITBC) Description & Operation – Option JL1 (cont'd)

CHECK TRAILER WIRING

This message will be displayed if:

- The ITBC system first determines connection to a trailer with electric brakes and then the trailer harness becomes disconnected from the vehicle. If the disconnect occurs while the vehicle is stationary, this message will automatically turn off in about thirty seconds. This message will also turn off if the driver acknowledges this message off or if the trailer harness is re-connected. If the disconnect occurs while the vehicle is moving, this message will continue until the ignition is turned off. This message will also turn off if the driver acknowledges this message off or if the trailer harness is re-connected.
- There is an electrical fault in the wiring to the electric trailer brakes. This message will continue as long as there is an electrical fault in the trailer wiring. This message will also turn off if the driver acknowledges this message off. To determine if the electrical fault is on the vehicle side or trailer side of the trailer wiring harness connection, do the following:
 1. Disconnect the trailer wiring harness from the vehicle.
 2. Turn the ignition OFF.
 3. Wait ten seconds, then turn the ignition back to RUN.
 4. If the **CHECK TRAILER WIRING** message re-appears, the electrical fault is on the vehicle side. If the **CHECK TRAILER WIRING** message only re-appears when you connect the trailer wiring harness to the vehicle, the electrical fault is on the trailer side.

SERVICE TRAILER BRAKE SYSTEM

This message will be displayed when there is a problem with the TBCM system. If this message persists over multiple ignition cycles there is problem with the TBCM system. Take your vehicle to an authorized GM dealer to have the TBCM system diagnosed and repaired.

TRAILER GAIN and OUTPUT Display

This display menu can be accessed by scrolling through the DIC vehicle Information menu, or any time the trailer gain +/- button is depressed, or the manual trailer brake apply lever is actuated. The trailer gain display is 0 to 10 in 0.5 step increments, and indicates the current user setting of the trailer output gain. The trailer output is 0 to 10 bars in 1 bar increments, and indicates the output power provided to the trailer brakes, relative to the gain setting.

Trailer Brake Controller Switch Location

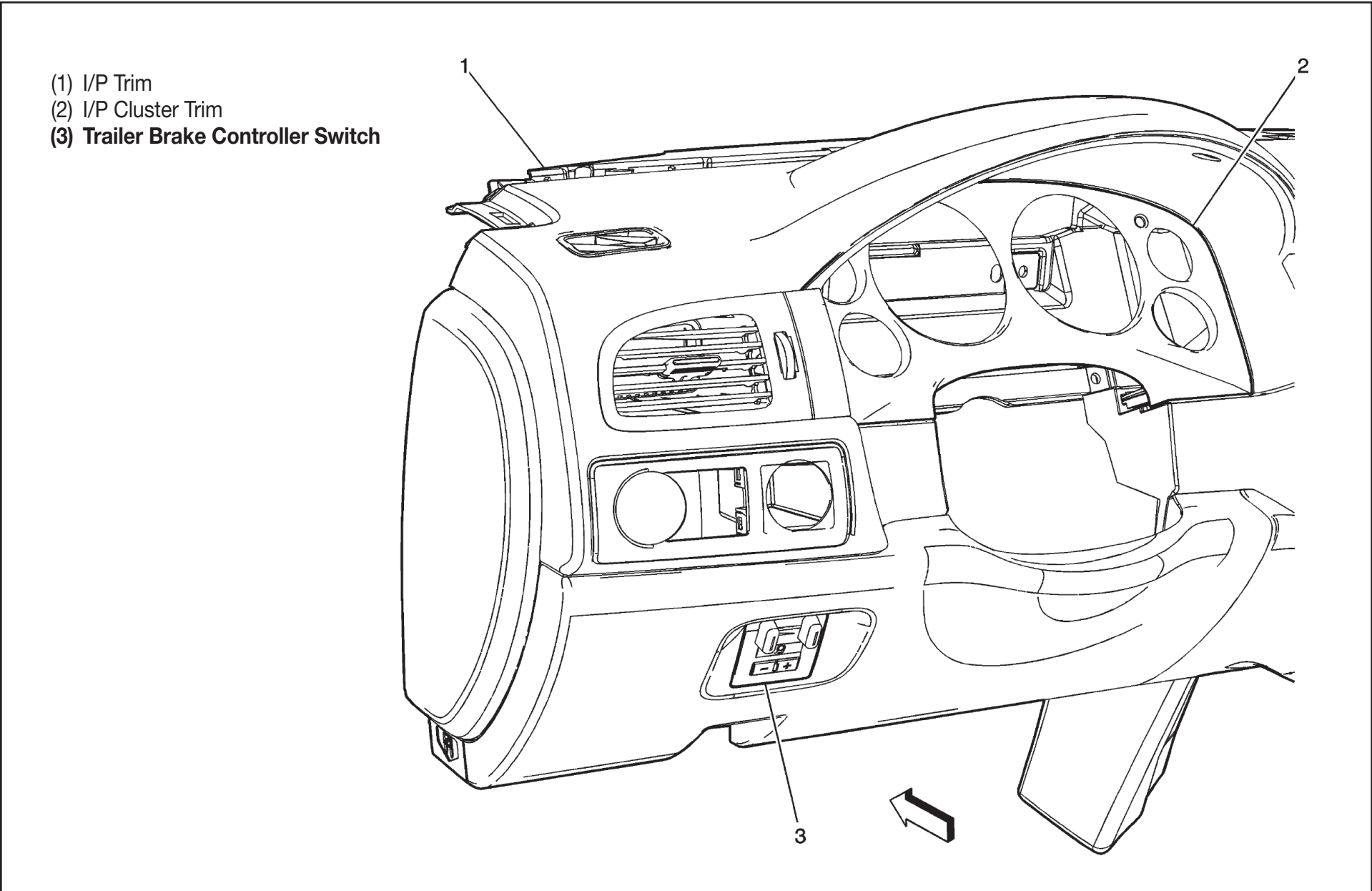

Trailer Brake Controller Module (TBCM) Location

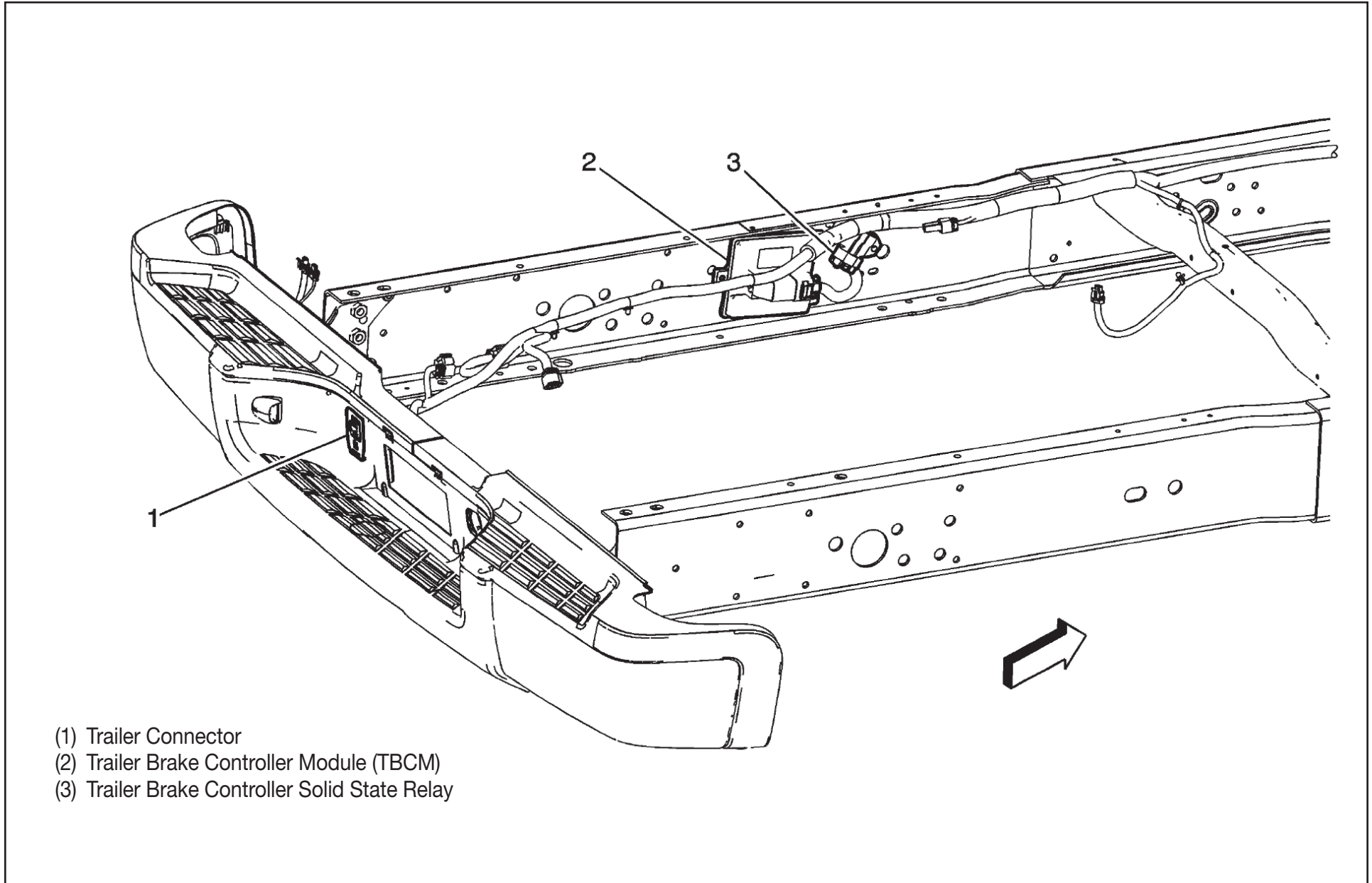

Automatic Transmission Shift Lock Control

Description and Operation

The automatic transmission shift lock control system is a safety device that prevents an inadvertent shift out of PARK when the engine is running. The driver must press the brake pedal before moving the shift lever out of the PARK position. The system consists of the automatic transmission shift lock solenoid (serviced as the automatic transmission shift lock actuator), as well as the Body Control Module (BCM) and Engine Control Module (ECM). The shift lock solenoid is located within the steering column assembly.

The BCM controls the voltage supply circuit of the shift lock control solenoid. The following conditions must be met before the BCM will supply voltage to the shift lock control solenoid:

- The ignition is in the ON position.
- The ECM sends an input via GMLAN serial data to the BCM indicating the transmission is in the PARK position.
- The BCM determines the brake pedal is not applied according to the stop lamp switch.

Since the shift lock control solenoid is permanently grounded, the BCM supplies voltage to the automatic transmission shift lock control solenoid, mechanically locking the shift lever in the PARK position as the solenoid energizes. When the brake pedal is applied, the BCM turns the control voltage output of the shift lock control solenoid OFF, de-energizing the shift lock control solenoid. The de-energized solenoid releases the mechanical lock allowing the driver to move the shift lever out of the PARK position. When the transmission is out of the PARK position, the shift lock control solenoid remains de-energized.

During remote start operation the BCM will energize the shift lock control circuit, locking the shift lever in the PARK position.

Cruise Control and/or PTO Inoperative

This copy excerpted from GM PI #PIT3051B (09/08/2006)

Cruise Control and/or PTO Inoperative - keywords engage lamp light #PIT3051B - (09/08/2006)

Models: 2003-2007 Chevrolet Silverado Classic
2003-2007 GMC Sierra Classic
2003-2007 Chevrolet Express Van
2003-2007 GMC Savana Van
1 Ton Vehicles Only

**This PI has been updated to add additional Model Years.
(Please discard PIT3051A).**

The following diagnosis might be helpful if the vehicle exhibits the symptom(s) described in this PI.

Condition/Concern:

Some customers may state that the Cruise Control and/or the Power Take Off Unit (PTO) may be in-op. If the vehicle was originally equipped with a Center High Mount Stop Lamp (CHMSL) assembly and the vehicle is a cut away or has been modified. It is possible that the CHMSL was removed or was ordered with CHMSL delete option (RPO TS9).

Recommendation/Instructions:

Install a 330 ohm 3/4 watt resistor in place CHMSL connector. If a connector is not available. Place the resistor between circuit 17 and secure the other end of the resistor to ground and tape to harness.

Please follow this diagnostic or repair process thoroughly and complete each step. If the condition exhibited is resolved without completing every step, the remaining steps do not need to be performed.



WE SUPPORT VOLUNTARY TECHNICIAN CERTIFICATION

GM bulletins are intended for use by professional technicians, NOT a "do-it-yourselfer". They are written to inform these technicians of conditions that may occur on some vehicles, or to provide information that could assist in the proper service of a vehicle. Properly trained technicians have the equipment, tools, safety instructions, and know-how to do a job properly and safely. If a condition is described, DO NOT assume that the bulletin applies to your vehicle, or that your vehicle will have that condition. See your GM dealer for information on whether your vehicle may benefit from the information.

Diesel Particulate Filter

Diesel Particulate Filter

Your vehicle has a Diesel Particulate Filter (DPF) as part of the exhaust system to reduce vehicle emissions. The DPF requires a unique exhaust tailpipe with an exhaust cooler. The exhaust cooler mixes air with the exhaust at the tailpipe. This lowers the exhaust temperature before it leaves the tailpipe.

The DPF, the tailpipe, or other exhaust system components must not be altered. The area where the exhaust cooler connects to the tailpipe should be inspected, especially the area where the fresh air enters the cooler. Make sure the openings are not restricted or plugged with mud or dirt which could inhibit exhaust gas cooling. See "Exhaust System Inspection" under *At Least Once a Year*.

The DPF will regenerate (self-clean) itself as part of normal operation. The Engine Control Module (ECM) controls this function based on several factors including the amount of fuel consumed, hours of engine operation and miles driven. On average, the DPF will clean itself about once per tank of fuel.

Notice: Use of diesel fuel other than Ultra Low Sulfur Diesel (15 ppm sulfur maximum) or engine oil other than low ash CJ-4 oil will cause permanent damage to the DPF and related components. This damage would not be covered by your warranty.

Your DPF equipped vehicle has specific fuel and engine oil requirements. See *What Fuel to Use* and *Engine Oil* to make sure you use the required fuel and engine oil.

Caution: During DPF regeneration, the exhaust system and exhaust gases are very hot. Things that burn could touch hot exhaust parts under your vehicle and ignite. You or others could be burned. Do not park near or over papers, leaves, dry grass, or other things that can burn.

If you have a pickup model and the **CLEAN EXHAUST FILTER SEE OWNERS MANUAL NOW** message appears in the Driver Information Center (DIC), the DPF needs to be cleaned. If you have a van model and the engine exhaust gas filter warning light, **CLN EXH FILTER**, comes on, the DPF needs to be cleaned. See *DIC Warnings and Messages* for pickup models, or *Engine Exhaust Gas Filter Warning Light* for van models.

To clean the filter, drive the vehicle above 30 mph (50 km/h) until the warning light/message goes off. This will take about 20 minutes.

Notice: Extended idle should be avoided because the DPF system is not capable of regenerating at idle. During extended idle, be sure to watch for the DPF warning light/message which could come on to indicate that the DPF is becoming full and needs regeneration. If the light/message comes on, stop the idling and drive the vehicle as described previously to clean the filter. Continued idling with the warning light/message on could cause irreversible damage to the DPF requiring repair and possible replacement that might not be covered by your warranty.

(continued on next page)

Diesel Particulate Filter (cont'd)

Extended idling in PARK (P) can cause exhaust parts and gases to become very hot. Keep the exhaust area clear of material that could ignite or burn. See *Parking Over Things That Burn* for more information.

The DPF warning light/message comes on when the DPF is dirty and needs regenerating. You will also notice a change in the exhaust sound and engine idle speed. This is normal.

If you continue to drive with the DPF warning light/message on and the exhaust filter is not cleaned as required, the check engine and reduced engine power warning lights will come on and dealer/retailer service is necessary. See *Malfunction Indicator Lamp* and *Reduced Engine Power Light* for more information.

For vehicles with Power Take-Off (PTO), monitor the instrument panel cluster for lights related to the DPF.

All engines consume some amount of engine oil. This is normal. The by-product of combustion of engine oil is ash. The ash will become trapped in the DPF over the life of the vehicle. Eventually, the buildup of ash will restrict the exhaust gases and the DPF will need to be cleaned or replaced.

See *Accessories and Modifications* for important information.

12-Volt Power Supply (SEO 9L4)

Electrical Connections

Your vehicle is equipped with wiring provisions for a 12-volt power supply (SEO 9L4). Refer to the following information when adding electrical accessories that will use the 9L4 12-volt power supply feeds connected to your vehicle's electrical system. After reading the following information, keep it with your owner's manual for future reference.

Notice: Before modifying or adding any wiring, be sure that it will work properly with your vehicle's wiring system. Because there are so many modifications that can be made for many different bodies and accessories, GM cannot take responsibility for any changes made. Such changes may not be covered by your GM Warranty. Have the work done by an experienced electrical technician. All wiring must be properly protected by fuses, etc. and must be routed properly so that it will not be cut, pinched or rubbed by other parts of the vehicle. Do not route wiring in areas where it will be very hot. Be sure not to overload the vehicle's wiring, connectors and components. All added wire must be at least the same size as the wire being attached to for proper fuse protection.

Installation Instructions – 12 Volt Accessory Power Supply

1. Disconnect the battery negative (-) cable at the battery. The negative (-) battery cable must be disconnected before the positive wiring lead is connected to the power accessory.
2. Locate the power supply harness under the instrument panel near the center of the vehicle. The wire bundle consists of six blunt cut wires, two red/white (battery hot), two black (ground), one light green (Ign hot) and one light blue (Ign hot).

3. Remove the tape to release the wire bundles from the power supply harness.
4. The IGN A and IGN B wires have voltage supplied and are HOT when the ignition is turned to ACC, RUN or RAP (Retained Accessory Power).

The BAT A and BAT B wires have direct voltage supplied and are HOT at all times.

The combined electrical load of IGN A and BAT A must not exceed 21 amps (250 watts). Additionally, the combined electrical load of IGN B and BAT B must not exceed 21 amps (250 watts). The combined electrical load of all circuits must not exceed 42 amps (500 watts).

5. Prepare the wires that are to be used to connect the power accessory. Do not remove the unused wires. Tape unused wires back in their original position under the instrument panel.
6. Complete the wiring installation of the customer added accessory with additional wire required for the specific electrical accessory power connection. The wire gage, 12 gage (3.0 mm²), should be the same as the wiring of the installed harness.
7. The ignition must be turned to OFF or ACC prior to attaching the cables to the battery, or serious damage to the Vehicle Control Module (VCM) may result.

The windshield wiper switch and the radio must be turned off before attaching cables to the battery.
8. Reconnect the battery negative (-) cable to the battery. Torque the bolt to 3.7 lb-ft. (5 N·m).
9. Reset the clock time and radio pushbuttons as desired.

LED or Additional Turn Signals

LED or Additional Turn Signals

Amber turn lamps on the NEW C/K Trucks are only used on the front of the vehicle. Rear lamps are combined stop/turn (red). Turn signals are controlled by the BCM. No flasher module is used. Adding additional bulbs will cause the BCM output to shut down resulting in no flashing. Replacing the front turn lamps with LED's will result in a rapid flash rate. This FMVSS required lamp outage detection is due to the change in lamp current through the BCM.

Two relays (left and right) need to be added for additional or LED turn signals. Power for the relays needs to go back to the UBEC. Turn signals are available at the forward lamp connectors. Information on these connectors is shown in Section C of the Utility Body Builders manual shown on the Upfitters website. The address of the manual is:

http://www.gmupfitter.com/publicat/2007_BB/2007_LD_FS_CK_Utility_Elec.pdf

Chevrolet Silverado and GMC Sierra Pickup forward light circuits are identical. They are similar to the Chevrolet SUV but lack the separate DRL lamps of the SUV. Daytime Running Lights are accomplished by reduced intensity headlamps. The Pickups use the same connectors as the Chevy SUV. C100 and C106 are shown on pages C-6 and C-9 of the Utility manual. There is no additional connector for the VYU (Snowplow) option. Requirements for Snowplows are shown. Adding additional lights or LED's have the same vehicle wiring requirements.

Note: The truck will not have Lamp (or LED) outage detection. Although the life of high-quality LED's are substantially longer than the bulbs they replace, it is the upfitter's responsibility for making this modification.

Additional Turn Signals – GMC Yukon (Z88)

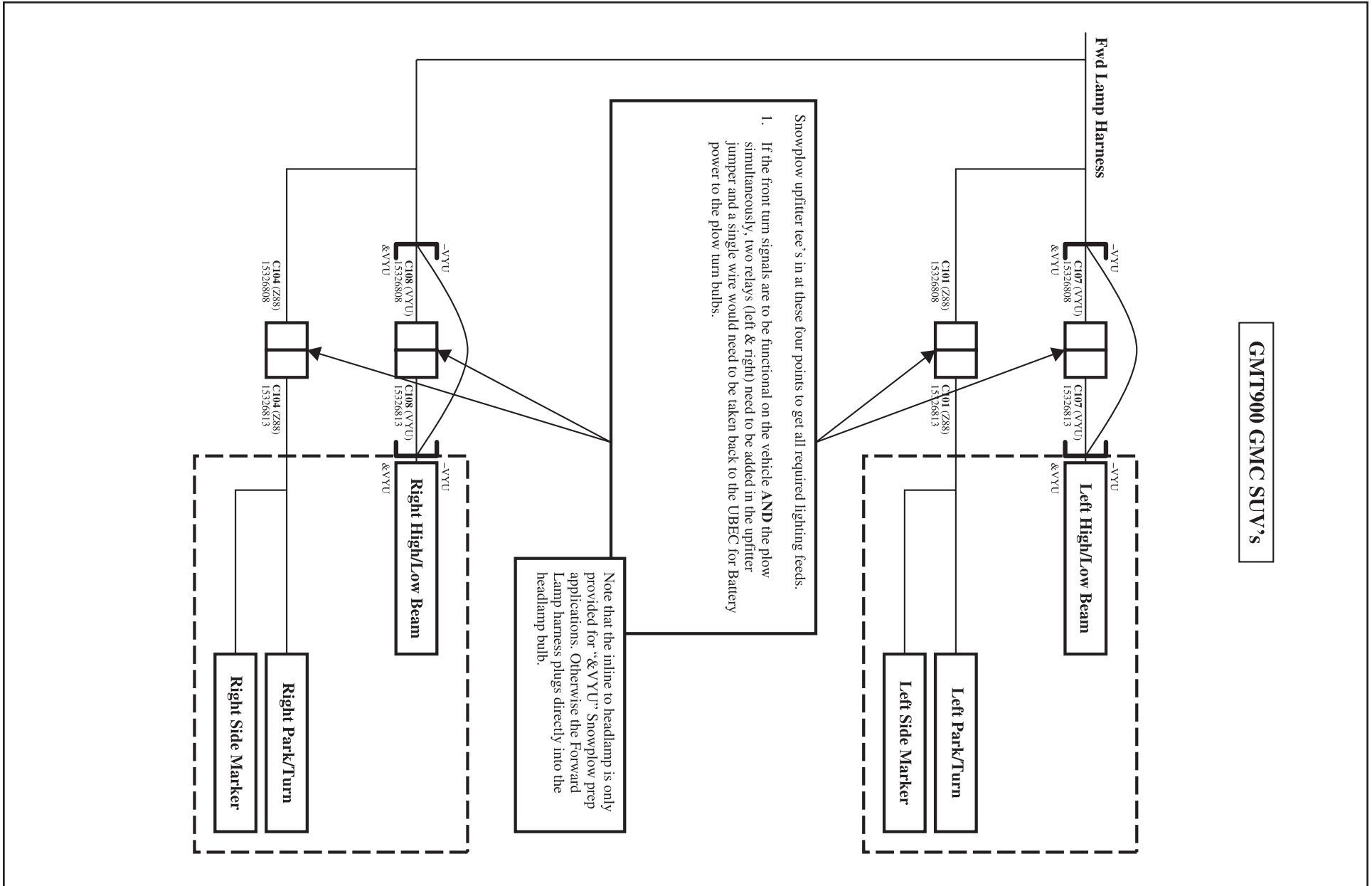

Additional Turn Signals – Chevrolet Tahoe & Suburban (X88)

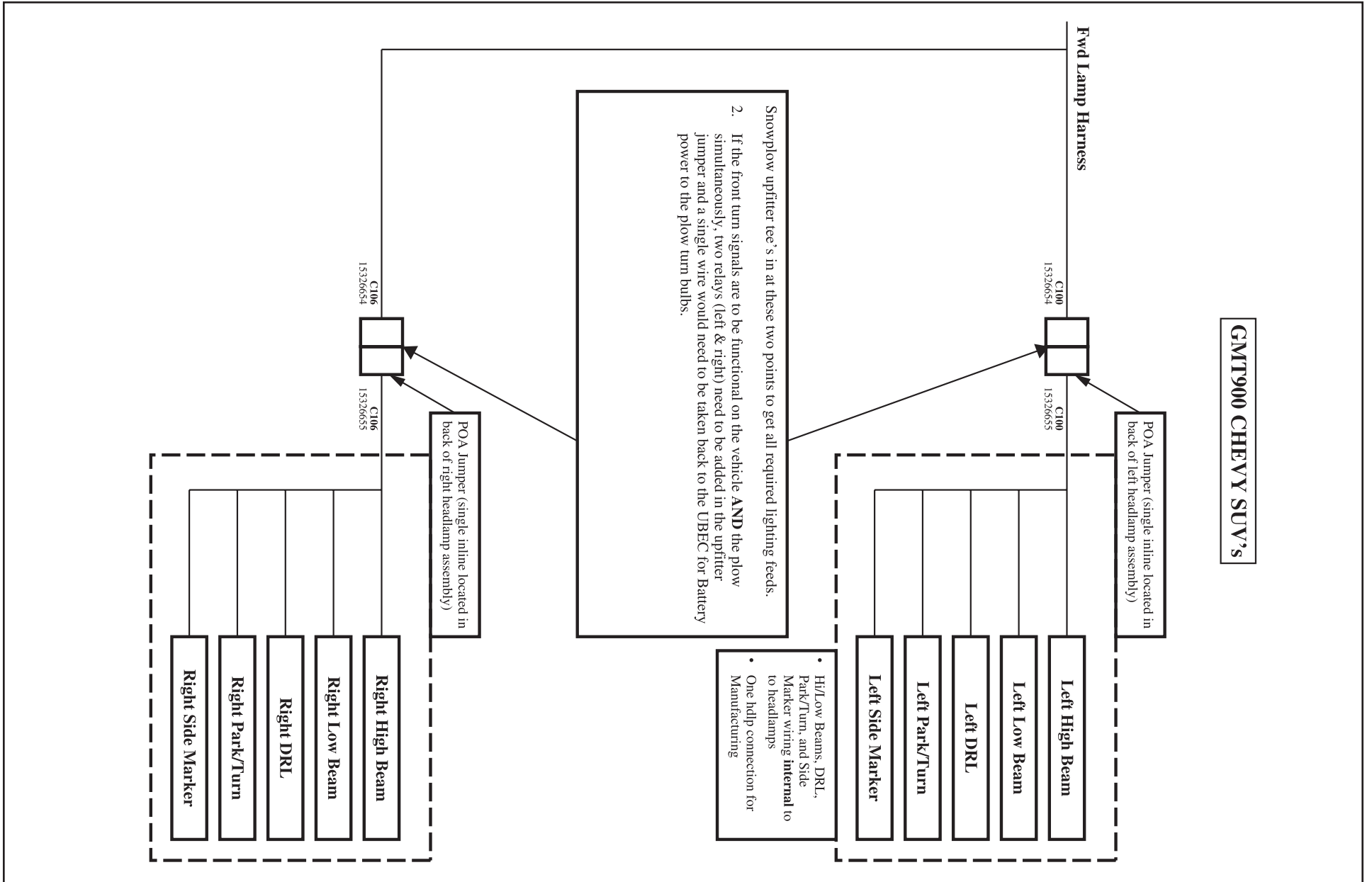

Additional Turn Signals – Chevrolet & GMC Pickups

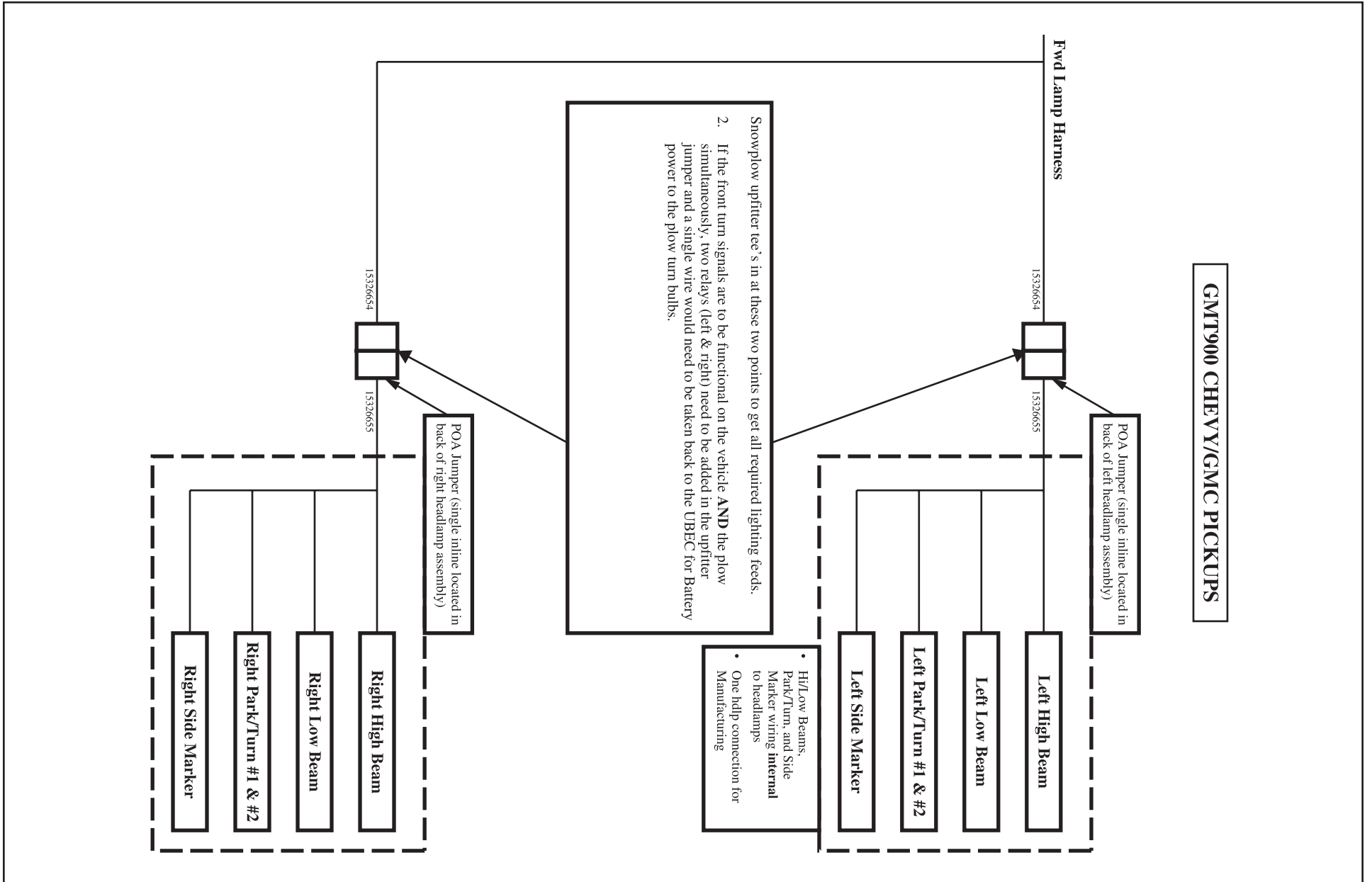

Service Body Rear Lighting Options (including LED)

This copy excerpted from GM UI Bulletin #81 (04/17/2007)

The address of the UI Bulletin #81 (and the accompanying Upfitter addendum #07-08-442-006) is:

http://www.gmupfitter.com/publicat/bull/63135_Bulletin_81_D3.pdf

Service Body Lighting Options (including LED)

Models Affected: All New C/K Chevrolet Silverado and GMC Sierra, 3500 Series Heavy Duty Chassis Cab, Pickups with Box Delete Option (RPO ZW9) and, Models Approved for Pickup Box Removal

SUMMARY

- Chassis Cab & ZW9 box delete option models will work with LED or any other turn signals without modification.
- Tail lamp alteration of a regular truck (i.e. deleting Pickup box w/o ZW9) needs to have the BCM calibration changed if LED's or single bulb lamps are used. This must be done at a dealer.

Service Bulletin (Document ID# 1956334) describes how the dealer can change the BCM calibration.

Notes: This bulletin addresses the "All New" not the "Classic" C/K truck.

FMVSS 108 / CMVSS 108 compliance is the responsibility of the upfitter.

Significant points are as follows:

- The Turn Signals are controlled by the BCM not a separate flasher module.
- Rear Lamp Bulb Outage detection is displayed as a "fast" turn signal flash rate in the cluster.
- All trucks are built with one of two BCM calibrations:
 - All "regular" C/K trucks - 2 Bulb Outage Detection
 - All Chassis Cabs & ZW9 box delete option – No Bulb Outage Detection. This may be used for LED turn signals with a standard flash rate.
 - Note: No calibration presently exists for Single Bulb Lamp Outage Detection.
- The BCM is current limited to 6A. The BCM output (& lamps) will turn off if this is exceeded.
- The "All New" C/K trucks have combined "red" stop/turn signal lamps.
- Adding additional turn only (Amber) signals are described in the Body Builders Manual.



WE SUPPORT VOLUNTARY TECHNICIAN CERTIFICATION

GM bulletins are intended for use by professional technicians, NOT a "do-it-yourselfer". They are written to inform these technicians of conditions that may occur on some vehicles, or to provide information that could assist in the proper service of a vehicle. Properly trained technicians have the equipment, tools, safety instructions, and know-how to do a job properly and safely. If a condition is described, DO NOT assume that the bulletin applies to your vehicle, or that your vehicle will have that condition. See your GM dealer for information on whether your vehicle may benefit from the information.

Service Body Rear Lighting Options – Pickup Box Delete (ZW9)

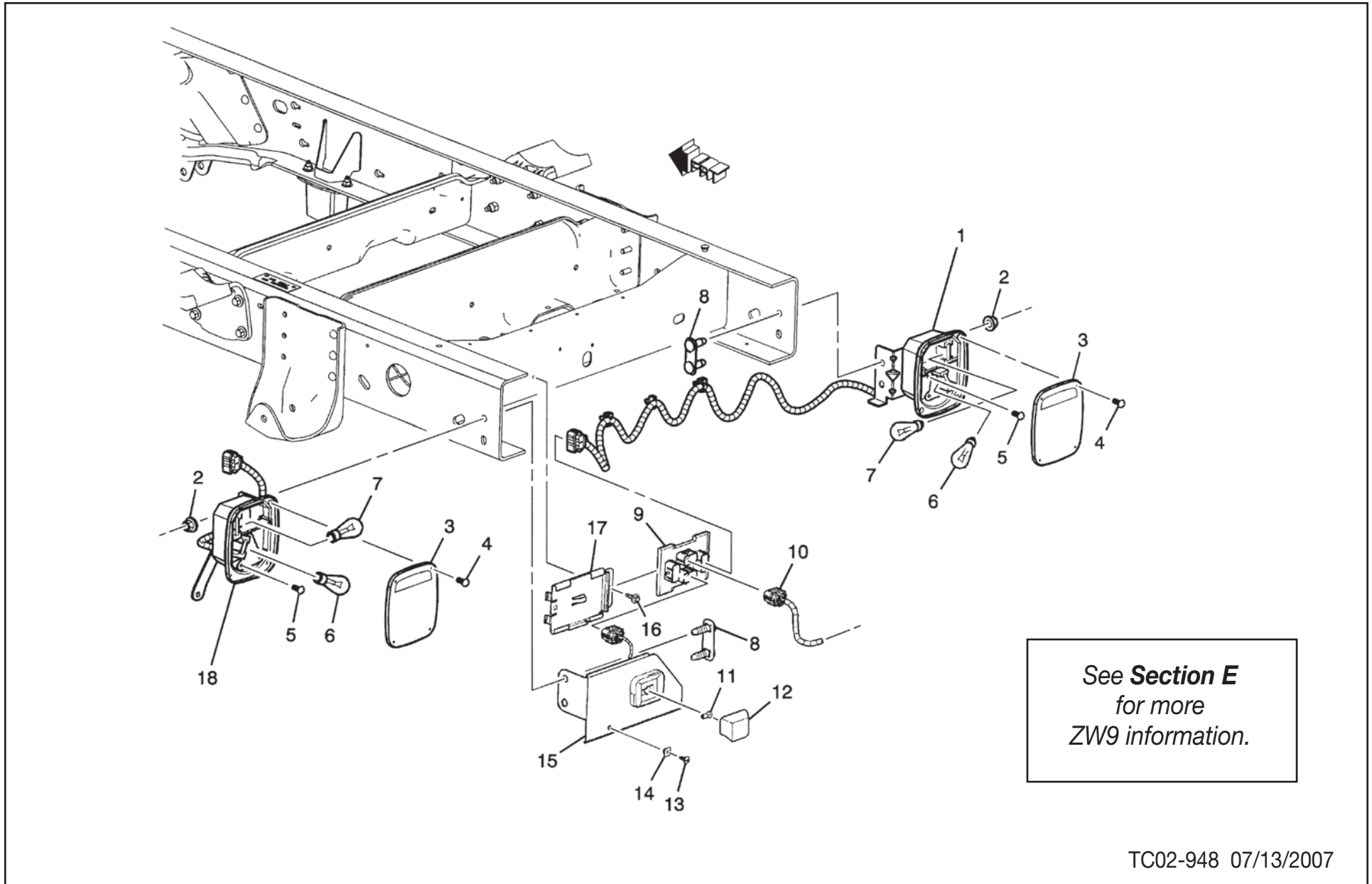

TC02-948 07/13/2007

Preface: Support Information

• Acronyms

- 2WD = Two Wheel Drive
- 4WD = Four Wheel Drive
- A/D = Analog to Digital
- AIR = Air Injection Reaction
- ACCY = Accessory
- AMP = Amplifier or "Current"
- ANLG = Analog
- A/V = Audio/Video
- ABS = Antilock Brake System
- AOS = Auxiliary Occupant Sensing
- ASM = Assembly
- AUX = Auxiliary
- AWD = All Wheel Drive
- BASS = Brake Apply Sensing System
- BATT = Battery
- BCM = Body Control Module
- BEC = Bussed Electrical Center
- BOT = Bottom Of Travel
- CHMSL = Center High Mounted Stop Lamp
- CTSY = Courtesy
- DDM = Driver Door Module
- DIC = Driver Information Center
- DLC = Diagnostic Link Connector
- DLIS = Discrete Logic Ignition Switch
- DOD = Displacement On Demand
- DR = Door
- DRL = Daytime Running Lamps
- DVC = Dual Voice Coil
- DVD = Digital Versatile Disc
- E85 = Ethanol 85%
- EAP = Electric Adjustable Pedals
- ECC = Electronic Climate Control
- ECM = Engine Control Module
- EGR = Exhaust Gas Recirculation
- EHPS = Electro-Hydraulic Power Steering
- EK = Easy Key
- EOSS = Engine Output Speed Sensor
- ESD = Electro Static Discharge
- ETC = Electronic Throttle Control
- EV = Electro-Viscous
- EXP = Export
- EXT = External or Exterior
- FREQ = Frequency
- FRT = Front
- FTP = Flash To Pass
- GMHS = GM High Speed LAN
- GMLS = GM Low Speed LAN
- GND = Ground
- GPM = Glow Plug Module
- GPS = Global Positioning System
- HCM = Hybrid Control Module

• Acronyms (continued)

- HDI = High Discrete Input
- HDLP = Headlamp
- HID = High Intensity Discharge
- HSD = High Side Drive
- HVSM = Heated/Vented Seat Module
- HVAC = Heat Vent Air Condition
- IAH = Intake Air Heater
- IAT = Intake Air Temperature
- INC DIM = Incandescent Dimming
- IND DIM = Indicator Dimming
- IPC = Instrument Panel Cluster
- IR = Infrared
- ISRV = Inside Rear View Mirror
- LBEC = Left BEC
- LDI = Low Discrete Input
- LF = Left Front
- LED = Light Emitting Diode
- LED DIM = LED Dimming
- LGM = Liftgate Module
- LH = Left Hand
- LIN = Linear Interconnect Network
- LOMA = Lifter Oil Manifold Assembly
- LPM = Linear Power Module
- LR = Left Rear
- LSD = Low Side Drive
- MAF = Mass Air Flow
- MAP = Manifold Absolute Pressure
- MAT = Manifold Air Temperature
- MBEC = Mid BEC
- MDD = Medium Duty Dual Side Clutch
- MDL = Module
- MOV = Metal Oxide Varistor
- MR = Magneto-Rheological
- MSM = Memory Seat Module
- MTR = Motor
- NC = Normally Closed
- NO = Normally Open
- OSRV = Outside Rear View Mirror
- PAS or PASS = Passenger
- PCP = Pre-Charge Pump
- PDM = Passenger Door Module
- PD = Pull Down
- POA = Part Of Assembly
- PPM = Pulse Per Minute
- PPS = Pedal Position Sensor
- PRNDL = Park Reverse Neutral Drive Low
- PSIR = Passenger SIR
- PTC = Positive Temperature Coefficient
- PTO = Power Take Off
- PTR = Powertrain Relay
- PU = Pull Up

• Acronyms (continued)

- PWM = Pulse Width Modulation
- PWR = Power
- R/C = Run/Crank
- RAP = Retained Accessory Power
- RF = Right Front
- RFA = Remote Function Actuator
- RH = Right Hand
- RHBLK = Right Hand Block (Bussing)
- RPO = Regular Product Option
- RR = Right Rear
- RRBLK = Rear Block (Bussing)
- RSA = Rear Seat Audio
- RSE = Rear Seat Entertainment
- RTD = Real Time Damping
- RVC = Regulated Voltage Control
- RWS = Rear Wheel Steer
- SBAT = Switched Battery
- SDARS = Satellite Digital Audio Radio Services
- SDM = Sensing & Diagnostic Module
- SENS = Sensor or Sensing
- SEO = Special Equipment Option
- SIR = Supplemental Inflatable Restraint
- SNRF = Sunroof
- SRC = Source
- STRG = Steering
- SW = Switch
- SWC = Steering Wheel Controls
- TCM = Transmission Control Module
- TED = Thermal Electrical Device (Platinum Cupholders)
- TISS = Transmission Input Speed Sensor
- TOSS = Transmission Output Speed Sensor
- TOT = Top Of Travel
- TPS = Throttle Position Sensor
- TRLR = Trailer
- TURSS = Turbine Speed Sensor
- TUTD = Tap Up Tap Down
- UBEC = Underhood BEC
- UGDO = Universal Garage Door Opener
- UPA = Ultrasonic Park Assist
- VAR = Variable
- VASS = Vehicle Access & Starting Security
- VHSS = Variable Height Suspension System
- VNC = Vehicle Noise Control
- VSES = Vehicle Stability Enhancement System
- WFHS = Washer Fluid Heating System
- WIF = Water In Fuel
- WUA = Wake Up Analog
- WUD = Wake Up Dual Edge
- WUF = Wake Up Falling Edge
- WUR = Wake Up Rising Edge
- XCVR = Transceiver

Preface: Support Information (cont'd)

•Miscellaneous Information

- C = 2WD
- K = 4WD
- 03 = Regular Cab Pickup
- 43 = Crew Cab Pickup
- 53 = Extended Cab Pickup
- 06 = Utility (Both 706 & 906)
- 706 = Regular Utility
- 906 = Large Utility
- 36 = Ultimate Utility Vehicle (UUV)
- 10 = Series (Pickup/Utility/UUV)
- 20 = Series (Pickup/Utility/UUV)
- 30 = Series (Pickup)
- 31 = Series (Cab Chassis)

•900 Numbers

- 901 - Light Duty Pickups - Chevy Silverado
- 902 - Light Duty Pickups - GMC Sierra, (GMC Sierra Denali?)
- 911 - Heavy Duty Pickups - Chevy Silverado
- 912 - Heavy Duty Pickups - GMC Sierra, (GMC Sierra Denali?)
- 921 - Utility - Chevrolet Tahoe
- 922 - Utility - GMC Yukon, (GMC Yukon Denali?)
- 926 - Utility - Cadillac Escalade
- 931 - Large Utility - Chevrolet Suburban
- 932 - Large Utility - GMC Yukon XL, (GMC Yukon Denali XL?)
- 936 - Large Utility - Cadillac Escalade ESV
- 941 - Sport Utility Truck - Chevrolet Avalanche
- 946 - Sport Utility Truck - Cadillac Escalade EXT

•Vehicles by RPO

- 03/43/53 = Chevrolet Silverado / GMC Sierra / GMC Sierra Denali
- 03/43/53&X88 = Chevrolet Silverado
- 03/43/53&Z88 = GMC Sierra / GMC Sierra Denali (43 Only)
- 06 = Cadillac Escalade / Cadillac Escalade ESV / Chevrolet Tahoe / Chevrolet Suburban / GMC Yukon / GMC Yukon Denali / GMC Yukon XL / GMC Yukon Denali XL
- 06&X88 = Chevrolet Tahoe / Chevrolet Suburban
- 06&Z75 = Cadillac Escalade / Cadillac Escalade ESV
- 06&Z88 = GMC Yukon / GMC Yukon Denali / GMC Yukon XL / GMC Yukon Denali XL
- 06&Z88&Y91 = GMC Yukon Denali / GMC Yukon Denali XL
- 36 = Chevrolet Avalanche / Cadillac Escalade EXT
- 36&X88 = Chevrolet Avalanche
- 36&Y91/Z75 = Cadillac Escalade EXT
- 43&Y91 = GMC Sierra Denali
- 43&Y91&Z88 = GMC Sierra Denali
- 706 = Cadillac Escalade / Chevrolet Tahoe / GMC Yukon / GMC Yukon Denali
- 706&X88 = Chevrolet Tahoe
- 706&Y91 = Cadillac Escalade / GMC Yukon Denali
- 706&Y91&Z88 = GMC Yukon Denali
- 706&Z75 = Cadillac Escalade
- 706&Z88 = GMC Yukon / GMC Yukon Denali
- 906 = Cadillac Escalade ESV / Chevrolet Suburban / GMC Yukon XL / GMC Yukon Denali XL
- 906&X88 = Chevrolet Suburban
- 906&Y91 = Cadillac Escalade ESV / GMC Yukon Denali XL
- 906&Y91&Z88 = GMC Yukon Denali XL
- 906&Z75 = Cadillac Escalade ESV
- 906&Z88 = GMC Yukon XL / GMC Yukon Denali XL

Preface: Support Information (cont'd)

•RPOs

- 03 = Regular Cab Pickup
- 06 = Utility (Applicable to both 706 & 906)
- 36 = Ultimate Utility Vehicle (UUV)
- 43 = Crew Cab Pickup
- 53 = Extended Cab Pickup
- 706 = Regular Utility
- 906 = Large Utility
- 5W4 = Special Service Package (4WD Police Package)
- (5W4 contains 6J1, 6J3, 6J4, 6J7, 7X6, 7X7, 9G8, TRW, WX7 & optionally 6A6)
- 5X7 = Provisions - Wrecker Emergency Lamp (SEO)
- 5Y0 = Wiring Provisions Body Builder Emergency Lamp (SEO)
- 6A6 - Dual Battery, 730 CCA
- 6J1 = Power Supply, 100Amp at Dash and Rear Compartment
- 6J3 = Wiring Provisions, Grill Lamp & Speakers
- 6J4 = Wiring Provision, Horn/Siren
- 6J7 = Wiring Provision, Head Lamp & Tail Lamp Flasher
- 7X6 = Spot Lamp, LH
- 7X7 = Spot Lamp, LH & RH
- 7Z1 = Horn - Dual Hight Note (SEO)
- 6A6 - Dual Battery, 600 CCA & 770 CCA (SEO)
- 8S3 = Alarm B/U Electrical 97 Decibels (SEO)
- 8S8 = Wiring Provisions Odometer Security (SEO) {Unused?}
- 8X5 = Generator 105 Amp, Dual (SEO) (w/o YF2)
- 906 = Large Utility
- 9G8 = DRL Delete
- 9L4 = Wiring Provisions 12V Power Supply
- A31 = Window, Electric Operated, Side
- A48 = Window RR Full Width, Sliding, Power
- ABV = Window Power Operated, RR Side Access Drs
- AG1 = Driver Power Seat
- AG2 = Passenger Power Seat
- AL0 = Auxiliary Occupant Sensing (AOS)
- AN3 = Memory Driver Seat
- AP3 = Lock Control, Entry Remote, Keyless Entry, Start
- AP8 = Lock Control, Entry Remote Entry, Extended Range (Remote Start Ready)
- ARS = Power Fold & Tumble 2nd Row Seats
- AS3 (with ASF) = Third Row Roof Rail Airbags
- ASF = Restraint Roof Side, LH & RH, Inflatable
- AU0 = Lock Control Remote Entry
- AU3-YE9 = Base Power Locks
- AZ3 = Seat Frt Split, Driver, Pass, Full Feature Center
- BRS = Retractable Runningboard
- C25 = Wiper/Washer System, Rear Window
- C36 = Heater Auxiliary
- C42 = Manual Heater Only
- C49 = Rear Window Defog
- C67 = HVAC System Air Conditioning FRT Electronic Controls
- C69 = HVAC System RR Air Conditioner
- C99 = Switch Infl Rst I/P Mdl Man Suppression

•RPOs (continued)

- CE1 = Wiper System Windshield, Pulse, Moisture Sensitive
- CF5 = Roof Sun, Glass, Sliding, Elec
- CJ2 = Dual HVAC System Auto Temp Cont
- CJ3 = Dual HVAC System Man Temp Cont
- D07 = Console Frt Compt, Floor, Custom
- DBL2751 = 2751 Double Ring Terminal
- DD8 = Mirror I/S R/V Electrochromic
- DH6 = Mirror I/S, Visor Vanity, LH & RH Sunshade (ILLUM)
- DL3 = Mirror O/S LH & RH, Rem Cont, Elec, Heat, Pwr Fold, Turn Sig, Electrochromic
- DL8 = Mirror O/S LH & RH, Rem Cont, Elec, Heated, Manual Fold
- DNU = Equipment, Additional DVD Screen
- DPN = OSRVM w/ Elect, Heat, Turn
- DR4 = OSRVM, Electric, Heated, Light Sensitive, Power Folding, Turn Signal (Export?)
- DT4 = Factory Installed Cigar Lighter (Cadillac Only)
- E52 = One Piece Lift Gate With Lift Glass
- E61 = Door RR Liftgate, Power
- EVA = Evap Emission
- EXPORT = European Export Content (awaiting RPO)
- G69 = Level Control Auto, Air, HD
- HVY = Heavy Duty Models (20HD, 30, 31)
- (-HVY) = Light Duty Models (10, 20LD)
- JD3 = Brake System, Vacuum, ABS Controls, 7,700 Lbs
- JF3 = Brake System, Vacuum, ABS Controls, 7,000 Lbs
- JF4 = Pedals Adjustable, Power
- JF7 = Brake System, Vacuum, ABS Controls, 6,400 Lbs
- JH6 = Brake Hyd Power, 4 Whl Disc, 9,900 Lbs
- JH7 = Brake Hyd Power, 4 Whl Disc, 12,300 Lbs
- JL1 = Integrated Trailer Brake Controller
- JL0 = Active Brake Control (VSES) Not Desired
- JL4 = Control Active Brake (VSES)
- K18 = Reactor System Air Injection, Electric
- K34 = Cruise Control, Electric
- K65 = Generators 105 Amp, Dual,
- KA6 = Heater Seat, Rear
- KA9 = Heater Steering Wheel
- KB6 = Heater Seat, Cooling, Frt
- L76 = 6.0L V8 Gasoline Engine (Aluminum - DOD)
- L92 = 6.0L V8 Gasoline Engine (Aluminum - DOD)
- LC9 = 5.3L V8 E85 Engine (Aluminum - DOD)
- LH6 = 5.3L V8 Gasoline Engine (Aluminum - DOD)
- LMG = 5.3L V8 Gasoline Engine (Iron - DOD) E85
- LMM = Engine Diesel 8 cyl, 6.6L, DPI, V8, Duramax
- LU3 = 4.3L V6 Gasoline Engine (Iron)
- LY2 = 4.8L V8 Gasoline Engine (Iron)
- LY5 = 5.3L V8 Gasoline Engine (Iron - DOD)
- LY6 = 6.0L V8 Gasoline Engine (Iron)
- M30 = Transmission Auto 4 Speed, HMD, 4L60E, Electronic
- M70 = Transmission Auto 4 Spd, HMD, 4L70-E, Super Duty
- M96 = Transmission Manual 5 Speed, Tremec, 190 mm

Preface: Support Information (cont'd)

•RPOs (continued)

- MW7 = Transmission Auto 5 Speed, Allison LCT, O/D, Conv Clutch
- MYC = Transmission Auto 6 Speed, HMD, 6L80
- MYD = Transmission Auto 6 Speed, HMD, 6L90
- NP8 = Transfer Case Active, 2 Speed, Push Button Cont.
- (-NQZ) = Dual Fuel Tanks (NQZ = 18 Gal Fuel Tank Delete)
- NQF = Transfer Case Electric Shift Cont, Two Speed, Alum
- NQG = Transfer Case Manual Shift Cont, Two Speed, Alum
- NQH = Transfer Case Active, Two Speed, Push Button Control, Alum
- PPV = Police Package (2WD)
- (PPV contains 6J1, 6J3, 6J4, 6J7, 7X6, 7X7, 9G8, JL0, TRW, WX7, & optionally 6A6)
- PTO = Provisions Power Take Off Controls
- R05 = Dual Rear Wheels
- SERIES10 = 10 Series (Pickup/Utility/UUV)
- SERIES20 = 20 Series (Pickup/Utility/UUV)
- SERIES30 = 30 Series (Pickup)
- SERIES31 = 31 Series (Cab Chassis)
- SPLSVRLS = Low Speed GMLAN Splice Saver
- T61 = Daytime Running Lamps
- T79 = Lamp Fog, Rr
- T96 = Lamp Fog, Frt
- TP2 = Auxiliary Battery
- TQ5 = Control Intelligent High Beam
- TR2 = Lamp Side Repeater (Export)
- TRW = Provisions - Roof Mount Emergency Lamp
- TZ0 = Transmission Manual 5 Speed, Tremec, 85 mm
- U01 = Lamp Five, Roof Marker, Truck
- U2K = Digital Audio System S-Band (SDARS)
- U3R = Radio AM/FM Stereo, WX, Seek/Scan, CD, DVD, Nav, Clock, DSP, RDS, w/Voice Rec Micro (Cadillac)
- U3U = Radio AM/FM Stereo, Seek/Scan, DVD, CD, Clock ETR, Navigation, Voice Rec, MP3 (Chevy/GMC)
- U42 = Entertainment System Rear Seat (DVD)
- U84 = Antenna Body Side Window, Radio
- UA6 = Theft Deterrent System (Export)
- UD7 = Sensor Indicator Rear Parking Assist (Ultrasonic)
- UE1 = OnStar Remote
- UG1 = Opener Garage Door, Universal
- UJ6 = Indicator Low Tire Press
- UK3 = Electronic System Steering Wheel Accessory Controls
- UK6 = Radio Control Rear Seat & Earphone Jacks (Only Available with UQA/UQS)
- UL5 = Radio Delete
- UQ3 = Uplevel Speaker Package
- UQ5 = Base Speaker Package
- UQA-Y91 = Premium Non-Luxury Speaker System (6-Channel Bose)
- UQA&Y91 = Premium Luxury Speaker System (9-Channel Bose)
- UQS = Premium Luxury Speaker System (9-Channel Bose with Surround)
- UVB = Radio AM/FM Stereo, Seek/Scan, Auto Tone, CD, CD-R MP3, DVD, Nav, Clock, ETR, RDS (Chevy/GMC Non-Luxury)
- UVC = Camera Rear View
- UY2 = Wiring Provisions Camper & 5th Wheel Trailer
- UY7 = Wiring Harness Truck Trailer, HD

•RPOs (continued)

- VYU = Provisions Snow Plow
- WX7 = Speaker Wiring Provision
- X88 = Chevrolet
- XA7 = Washer Nozzles, Heated, Windshield (WFHS)
- Y91 = Luxury Trim (Includes YE9)
- YE9 = Uplevel Trim
- (-YE9) = Base Trim
- YF2 = Sales Package Ambulance Upfitter (Generators, Lighting)
- Z49 = Export Canadian Modif Mandatory Base Equipment
- Z55 = Chassis Package Bi-State Real Time Damping
- Z75 = Cadillac
- Z82 = Trailer Provisions Special Equipment, H.D.
- Z88 = GMC

Power Distribution: Pickup - Fuse Block Underhood, View - Label

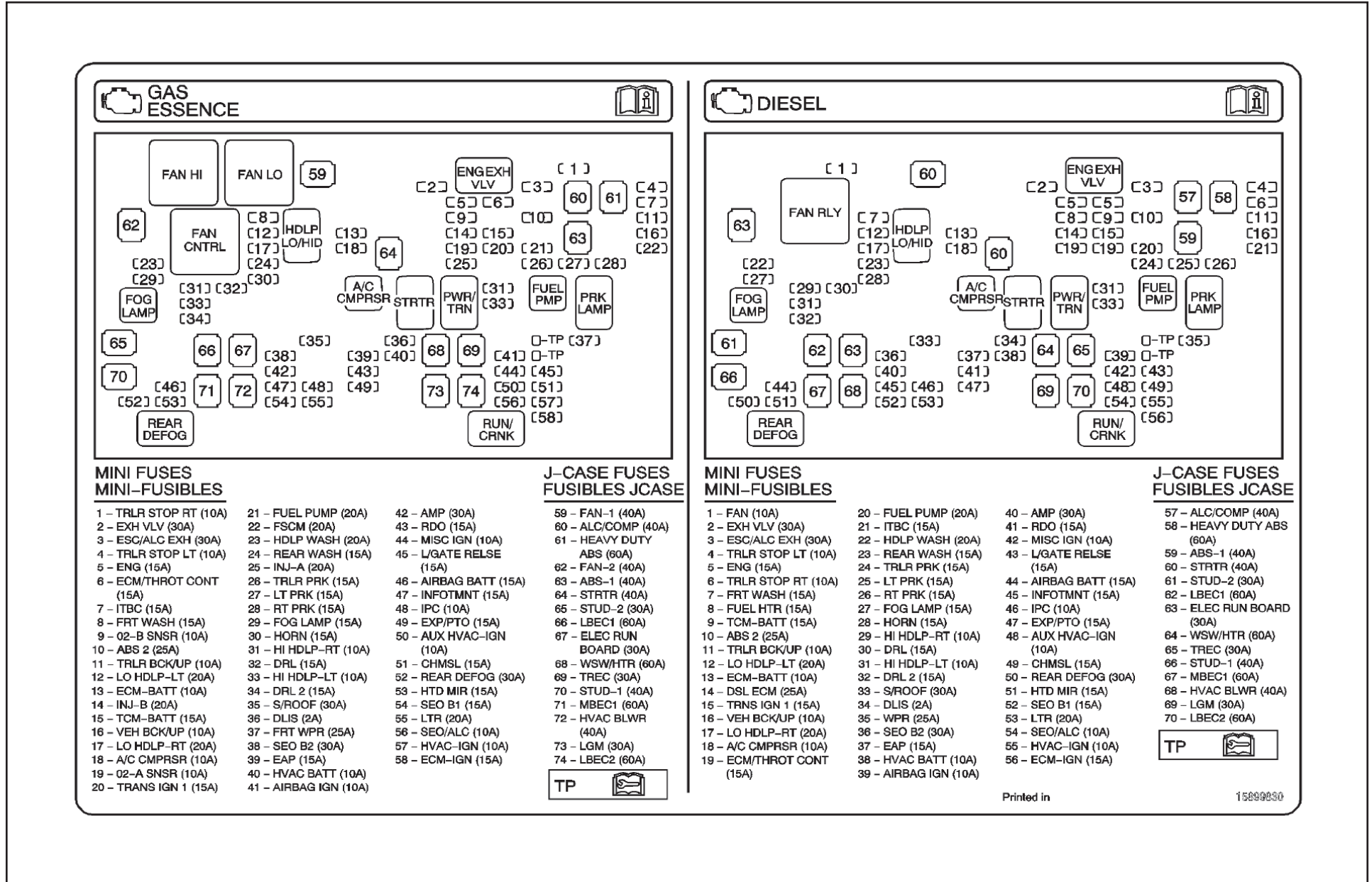

Power Distribution: Pickup - Fuse Block - Underhood, Top View - Diesel

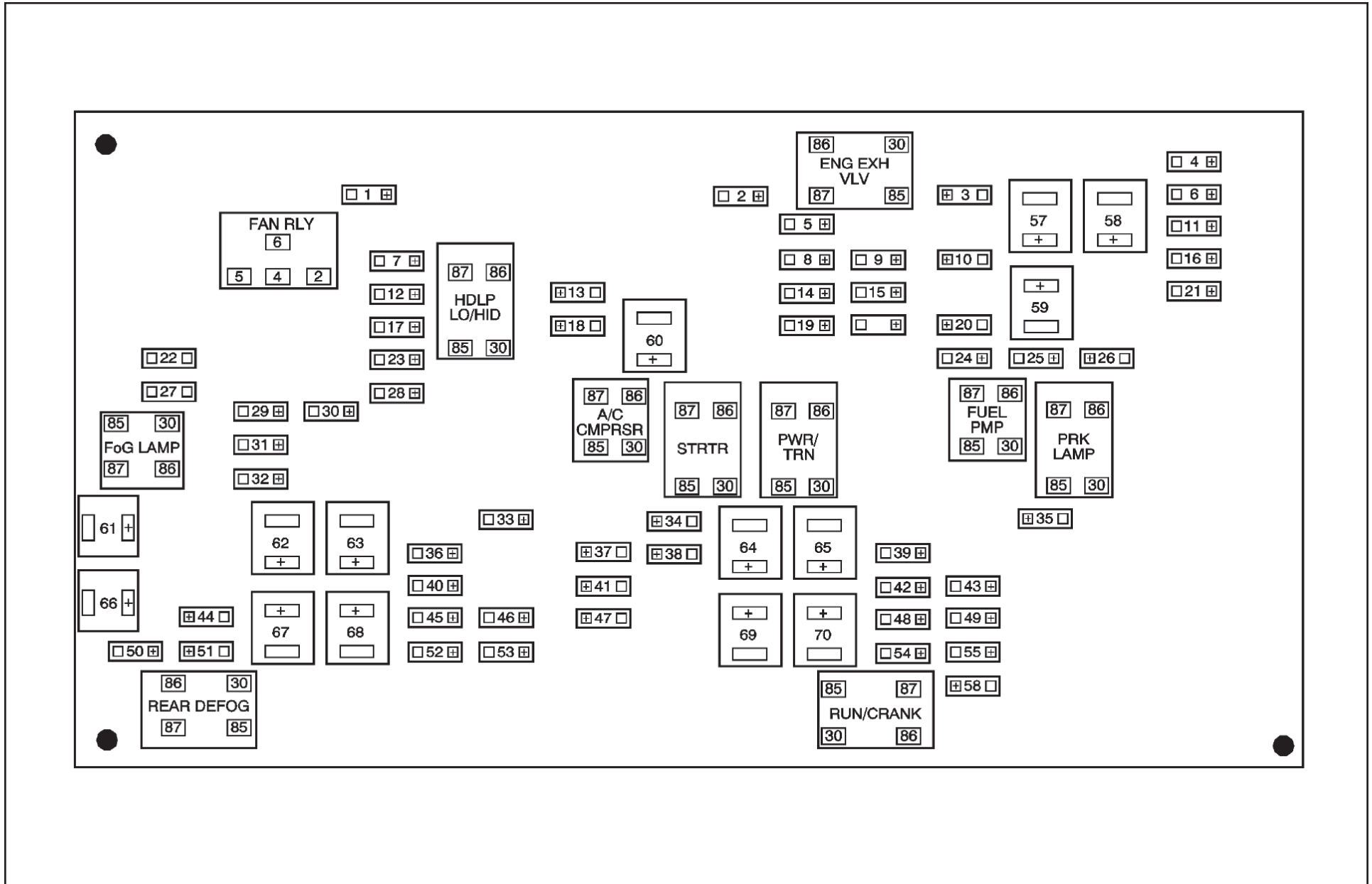

Power Distribution: Pickup - Fuse Block - Underhood, Top View - Gas

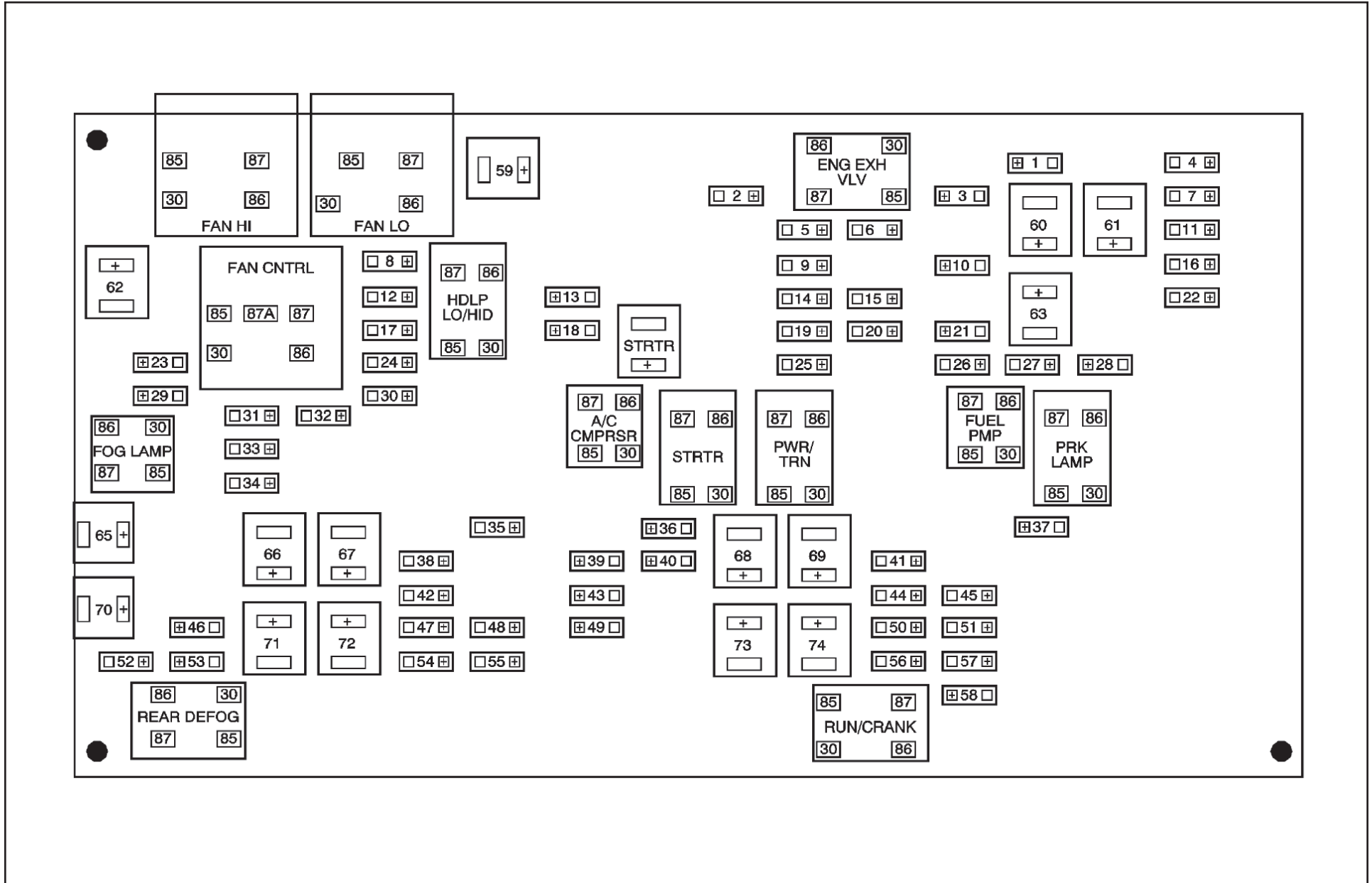

Power Distribution: Pickup - Fuse Block - Underhood, Bottom View

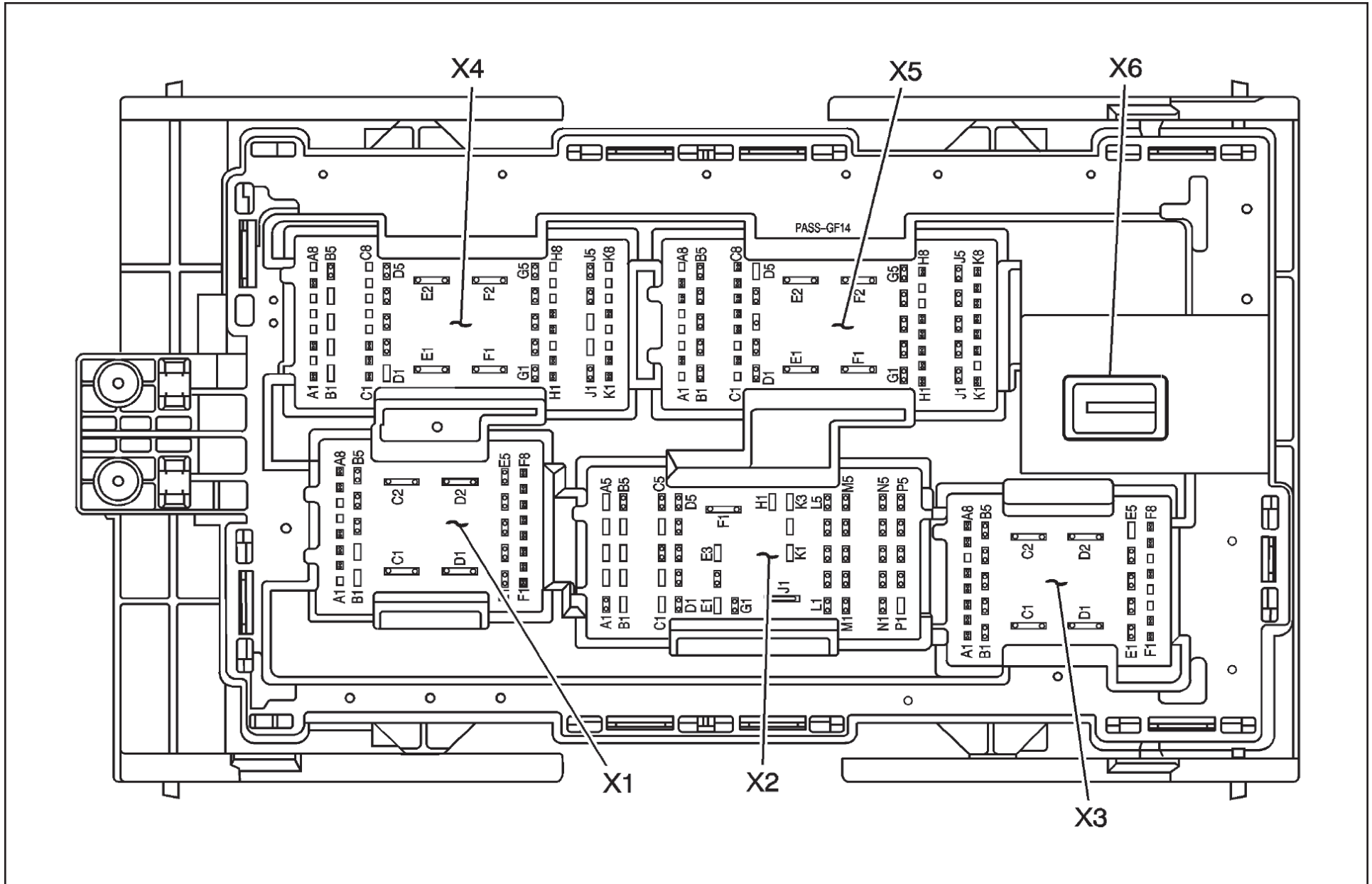

Power Distribution: Pickup - Underhood, Device Usage - Diesel (cont'd)

Fuse Block - Underhood, Device Usage - Diesel			
No.	Device	Rating	Description
1	FAN Fuse	10A	Fan Relay
2	EXH VLV Fuse	30A	Not Used
3	ESC/ALC EXH Fuse	30A	Not Used
4	TRLR STOP LT	10A	Trailer Wiring, Auxiliary Body Control
5	ENG Fuse	15A	Mass Air Flow (MAF)/Intake Air Temperature (IAT) Sensor
6	TRLR STOP RT Fuse	10A	Trailer Wiring, Auxiliary Body Control Module (XBCM) (Expert)
7	FRT WASH Fuse	15A	Windshield Washer Fluid Pump
8	Fuel HTR Fuse	15A	Glow Plug Control Module (GPCM), Fuel Heater
9	TCM-BATT Fuse	15A	Transmission Control Module (TCM)
10	ABS 2 Fuse	25A	Electronic Brake Control Module (EBCM)
11	TRLR BCK/UP Fuse	10A	Trailer Wiring
12	LO HDLP-LT Fuse	20A	Headlamp-Low Beam-Left
13	ECM-BATT Fuse	10A	Engine Control Module (ECM)
14	DSL ECM Fuse	25A	Engine Control Module (ECM)
15	TRANS IGN 1 Fuse	15A	Transmission Control Module (TCM), Front Axle Actuator (NQF/NQG)
16	VEH BCK/UP Fuse	10A	Backup Lamp-Left, Backup Lamp-Right
17	LO HDLP-RT Fuse	20A	Headlamp-Low Beam-Right
18	A/C CMPRSR Fuse	10A	A/C Compressor Clutch
19	ECM/THROT CONT Fuse	15A	Engine Control Module (ECM)
20	FUEL PUMP Fuse	20A	Fuel Pump and Sender Assembly-Primary
21	ITBC Fuse	15A	Integrated Trailer Brake Controller (ITBC) Module (JL1)
22	HDLP WASH Fuse	20A	Not Used

Fuse Block - Underhood, Device Usage - Diesel			
No.	Device	Rating	Description
23	REAR WASH Fuse	15A	Not Used
24	TRLR PRK Fuse	15A	Trailer Wiring
25	LT PRK Fuse	15A	License Lamp-Left, Marker Lamp-LF (Z88), Park/Turn Signal Lamp-LF Upper, Park/Turn Signal Lamp-LF Lower, marker Lamp-LR (Z88), Tail/Stop and Turn Signal Lamp-Lower Left, Tail/Stop and Turn Signal Lamp-Upper Left, Clearance Lamp-LF (R05), Clearance Lamp-LR (R05), Clearance Lamp (U01), Roof Marker Lamp-Left (U01), Roof Marker Lamp-Right (U01)
26	RT PRK Fuse	15A	Marker Lamp-RF (Z88), Park/Turn Signal Lamp-RF Upper, Park/Turn Signal Lamp-RF Lower, Tail/Stop and Turn Signal Lamp-Lower Right, Tail/Stop and Turn Signal Lamp-Lower Right, Marker Lamp-RR (Z88), License Lamp-Right Clearance lamp-RR (R05), Marker Lamp-Tailgate
27	FOG LAMP Fuse	15A	Fog Lamp-LF (T96), Fog Lamp-LF (T96)
28	HORN Fuse	15A	Horn, left, Horn-Right (7Z1)
29	HI HEADLAMP-RT Fuse	10A	Headlamp-High Beam-Right
30	DRL Fuse	15A	DRL 2 Fuse
31	HI HEADLAMP-LT Fuse	10A	Headlamp-High Beam-Right
32	DRL 2 Fuse	15A	LO HDLP-LT Fuse, LO HDLP-RT Fuse
33	S/ROOF Fuse	30A	Sunroof Module (CF5), Roof Beacon Relay (TRW)
34	DLIS Fuse	2A	Ignition Switch, Theft Deterrent Module (TDM)
35	WPR Fuse	25A	Wiper 1 PCB Relay
36	SEO B2 Fuse	30A	Emergency Vehicle Roof Lamp Relay (5Y0)

Power Distribution: Pickup – Underhood, Device Usage – Diesel (cont'd)

Fuse Block – Underhood, Device Usage – Diesel				Fuse Block – Underhood, Device Usage – Diesel			
No.	Device	Rating	Description	No.	Device	Rating	Description
37	EAP Fuse	15A	PARK ENABLE Relay, ELECTRONIC ADJUSTABLE PEDALS Relay, I/P Multi-function Accessory Switch	50	REAR DEFOG Fuse	30A	Defogger Grid
38	HVAC BATT Fuse	10A	HVAC Control Module	51	HTD MIR Fuse	15A	Outside Rearview Mirror-Driver (-AN3), Outside Rearview Mirror-Passenger (-AN3)
39	AIRBAG IGN Fuse	10A	Inflatable Restraint Sensing and Diagnostic Module (SDM), Inflatable Restraint Passenger Air Bag ON/OFF Indicator, Inflatable Restraint I/P Module Disable Switch (C99)	52	SEO B1 Fuse	15A	Auxiliary Body Control Module (XBCM) (Export), Power Take Off-(PTO) Module
40	AMP Fuse	30A	Audio Amplifier (UQA)	53	LTR Fuse	20A	Auxiliary Power Outlet-Front 1, Data Link Connector (DLC)
41	RDO Fuse	15A	Digital Radio Receiver (U2K), Radio, Rear Seat Audio (RSA) Controller (UK6)	54	SEO/ALC Fuse	10A	Not Used
42	MISC IGN Fuse	10A	Auxiliary Body Control Module (XBCM) (Export), Stop Lamp Switch, Transfer Case Shift Control Module (NQF/NQH), Integrated Trailer Brake Controller (ITBC) Module (JL1)	55	HVAC-IGN Fuse	10A	Air Temperature Actuator-Left (CJ2), Air Temperature Actuator-Right (CJ2), Air Temperature Actuator (C67), Mode Actuator, Recirculation Actuator (CJ2/C67)
43	L/GATE RELSE Fuse	15A	Not Used	56	ECM-IGN Fuse	15A	Engine Control Module (ECM), Fuel Pump Relay-Secondary (LY6-NQZ), Fuel System Control Module (FSCM)
44	AIRBAG BATT Fuse	15A	Inflatable Restraint Passenger Presence System (PPS) Module, Inflatable Restraint Sensing and Diagnostic Module (SDM), Inflatable Restraint Vehicle Roll-over Sensor (ASF)	57	ALC/COMP Fuse	40A	Not Used
45	INFOTMNT Fuse	15A	Video Display (U42), Rear Video Display (DNU), Vehicle Communication Interface Module (VCIM) (UE1)	58	HEAVY DUTY ABS Fuse	60A	Electronic Brake Control Module (EBCM)
46	IPC Fuse	10A	Body Control Module (BCM), Instrument Panel Cluster (IPC)	60	STRTR Fuse	40A	Starter
47	EXP/PTO Fuse	15A	Auxiliary Body Control Module (XBCM) (Export)/Power Take Off Relay (PTO)	61	STUD-2 Fuse	30A	Blunt Cut Wire, Integrated Trailer Brake Controller Solid State Relay (JL1)
48	AUX HVAC-IGN Fuse	10A	Instrument Panel Cluster (IPC), Inside Rearview Mirror (ISRV), Heated Steering Wheel Module (KA9)	62	LBECI Fuse	60A	AUX PWR 2 Fuse, REAR WPR Fuse, PDM Fuse, AUX PWR Fuse
49	CHMSL Fuse	15A	Cargo Lamp/Center High Mounted Stop Lamp (CHMSL)	63	ELEC RUN BOARD Fuse	30A	Not Used
				64	WSW/HTR Fuse	60A	Windshield Washer Solvent Heater (XA7)
				65	TREC Fuse	30A	Transfer Case Shift Control Module (NQF/NQH)
				66	Stud-1 Fuse	40A	Trailer Wiring
				67	MBEC1 Fuse	60A	DRIVER SEAT 2 Circuit Breaker, PASSENGER SEAT 1 Circuit Breaker

Power Distribution: Pickup – Underhood, Device Usage – Diesel (cont'd)

Fuse Block – Underhood, Device Usage – Diesel			
No.	Device	Rating	Description
68	HVAC BLWR Fuse	40A	Blower Motor Control Module
69	LGM Fuse	30A	Not Used
70	LBEC2 Fuse	60A	BCM Fuse, COOLED SEATS Fuse, DDM Fuse, DIM Fuse, DSM Fuse, REAR HVAC Fuse, RT STOP TRN Fuse, WSW PUMP Fuse
--	A/C COMPRSR Relay	--	A/C CMPRSR Fuse
--	ENG EXH VLV Relay	--	AXH VLV Fuse
--	FAN RLY Relay	--	Cooling Fan
--	FOG LAMP Relay	--	FOG LAMP Fuse
--	FUEL PUMP Relay	--	FUEL PUMP Fuse
--	HDLP LO/HID Relay	--	LO HDLP-LT Fuse, LO HDLP-RT Fuse, DRL 2 Fuse
--	PARK LAMP Relay	--	LT PRK Fuse, PRK Fuse, TRLR PRK Fuse
--	PWR/TRN Relay	--	DSL ECM Fuse, ECM/THROT Fuse, ENG Fuse, Fan Fuse, FUEL HTR Fuse
--	REAR DEFOG Relay	--	REAR DEFOG Fuse
--	RUN/CRNK Relay	--	AIRBAG Fuse, AUX HVAC-IGN Fuse, IGN Fuse, ECM-IGN Fuse, MISC IGN Fuse, SEO/ALC Fuse, TRANS IGN 1 Fuse
--	STRTR Relay	--	STRTR Fuse
Note: Relays listed below are non-serviceable Printed Circuit Board (PCB) relays and are internal to the block.			
--	BCK/UP LAMP PCB Relay	--	VEH BCK/UP Fuse, TRLR BCK/UP Fuse
--	DRL PCB Relay	--	DRL Fuse
--	FRT WASH PCB Relay	--	FRT WASH Fuse

Fuse Block – Underhood, Device Usage – Diesel			
No.	Device	Rating	Description
--	HI BEAM PCB Relay	--	HI HEADLAMP-LT Fuse, HI HEADLAMP-RT Fuse
--	HORN PCB Relay	--	HORN Fuse
--	L/GATE PCB Relay	--	L/GATE RELSE Fuse
--	LOCK PCB Relay	--	LCK 2 Fuse (YE9)
--	LOCK/UNLOCK PCB Relay	--	LCK 1 Fuse, LCK 2 Fuse, UNLCK 1 Fuse, UNLCK 2 Fuse (AU3-YE9)
--	REAR WASH PCB Relay	--	REAR WASH Fuse
--	TRLR STOP LT PCB Relay	--	TRLR STOP LT Fuse
--	TRLR STOP RT PCB Relay	--	TRLR STOP RT Fuse
--	UNLOCK PCB Relay	--	DRV UNLCK Fuse, UNLCK 1 Fuse, UNLCK 2 Fuse
--	WIPER CONTROL PCB Relay	--	Windshield Wiper Motor
--	WIPER SPEED PCB Relay	--	Windshield Wiper Motor

Power Distribution: Pickup – Underhood, Device Usage – Gas

Fuse Block – Underhood, Device Usage – Gas			
No.	Device	Rating	Description
1	TRLR STOP RT Fuse	10A	Trailer Wiring, Auxiliary Body Control Module (XBCM) (Export)
2	EXH VLV Fuse	30A	Not Used
3	ESC/ALC EXH Fuse	30A	Not Used
4	TRLR STOP LT Fuse	10A	Trailer Wiring, Auxiliary Body Control Module (XBCM) (Export)
5	ENG Fuse	15A	Central Sequential Fuel Injection (Central SFI) (4.3L), Evaporative Emissions (EVAP) Cannister Purge Solenoid Valve (4.8L, 5.3L, 6.0L and 6.2L), Mass Air Flow (MAF)/Intake Air Temperature (IAT) Sensor, Valve Lifter Oil Manifold (VLOM) Assembly
6	ECM/THROT CONT Fuse	15A	Engine Control Module (ECM)
7	ITBC Fuse	15A	Integrated Trailer Brake Controller (ITBC) Module (JL1)
8	FRT WASH Fuse	15A	Windshield Washer Fluid Pump
9	02-B SNSR Fuse	10A	Heated Oxygen Sensor (H02S) Bank 1 Sensor2, Heated Oxygen Sensor (H02S) Bank 2 Sensor 2
10	ABS 2 Fuse	25A	Electronic Brake Control Module (EBCM)
11	TRLR BCK/UP Fuse	10A	Trailer Wiring
12	LO HDLP-LT Fuse	20A	Headlamp-Low Beam-Left
13	ECM-BATT Fuse	10A	Engine Control Module (ECM)
14	INJ-B Fuse	20A	Fuel Injector2, Fuel Injector 4, Fuel Injector 6, Fuel Injector 8, Injector Coil 2, Ignition Coil 4, Ignition Coil 6, Ignition Coil 8
15	TCM-BATT Fuse	15A	Transmission Control Module (TCM)
16	DSL ECM Fuse	25A	Engine Control Module (ECM)
17	TRANS IGN 1 Fuse	15A	Transmission Control Module (TCM), Front Axle Actuator (NQF/NQG)

Fuse Block – Underhood, Device Usage – Gas			
No.	Device	Rating	Description
18	VEH BACK/UP Fuse	10A	Backup Lamp-Left, Backup Lamp-Right
19	LO HDLP-RT Fuse	20A	Headlamp-Low Beam-Right
20	A/C CMPSRSR Fuse	10A	A/C Compressor Clutch
21	02-A SNSR Fuse	10A	Heated Oxygen Sensor (H02S) Bank 1 Sensor 1, Heated Oxygen Sensor (H02S) Bank 2 Sensor 1
22	TRANS IGN 1 Fuse	15A	Transmission Control Module (TCM), 1-2 Shift Solenoid (1-2 SS) Valve, 2-3 Shift Solenoid (2-3 SS) Valve, 3-2 Shift Solenoid (3-2 SS) Valve (M30/M70), Torque Converter Clutch (TCC) Solenoid Valve (M30/M70), Torque Converter Clutch Pulse Width Modulation (TCC PWM) Solenoid Valve
23	FUEL PUMP Fuse	20A	Fuel Pump and Sender Assembly-Primary (-FSCM)
24	FSCM Fuse	20A	Fuel System Control Module (FSCM)
25	HDLP WASH Fuse	20A	Not Used
26	REAR WASH Fuse	15A	Not Used
27	INJ-A Fuse	20A	Fuel Injector 1, Fuel Injector 3, Fuel Injector 5, Fuel Injector 7, Ignition Coil 1, Ignition Coil 3, Ignition Coil 5, Ignition Coil 7
28	TRLR PRK Fuse	15A	Trailer Wiring
29	LT PRK Fuse	15A	License Lamp-Left, Marker Lamp-LF (Z-88), Park/Turn Signal Lamp-LF Upper, Park/Turn Signal Lamp-LF Lower, Marker Lamp-LR (Z88), Tail/Stop and Turn Signal Lamp-Lower Left, Tail/Stop and Turn Signal Lamp-Upper Left, Clearance Lamp-LF (R05), Clearance Lamp-LR (R05), Clearance Lamp (U01), Roof Marker Lamp-Left (U01), Roof Marker Lamp-Right (U01)

Power Distribution: Pickup – Underhood, Device Usage – Gas (cont'd)

Fuse Block – Underhood, Device Usage – Gas			
No.	Device	Rating	Description
30	RT PRK Fuse	15A	Marker Lamp-RF (Z88), Park/Turn Signal Lamp-RF Upper Park/Turn Signal Lamp-RF Lower Tail/Stop and Turn Signal Lamp-Lower Right, Tail/Stop and Turn Signal Lamp-Lower Right, Marker Lamp-RR (Z88), License Lamp-Right Clearance Lamp-RF (R05), Clearance Lamp-RR (R05), Marker Lamp-Tailgate
31	FOG LAMP Fuse	15A	Fog Lamp-LF (T-96), Fog Lamp- LF (T96)
32	HORN Fuse	15A	Horn-Left, Horn-Right (7Z1)
33	HI HEADLAMP-RT Fuse	10A	Headlamp-High Beam-Right
34	DRL Fuse	15A	DRL 2 Fuse
35	HI HEADLAMP-LT Fuse	10A	Headlamp-High Beam-Right
36	DRL 2 Fuse	15A	LO HDLP-LT Fuse, LO HDLP-RT Fuse
37	S/ROOF Fuse	30A	Sunroof Module (CF5), Roof Beacon Relay (TRW)
38	DLIS Fuse	2A	Ignition Switch, Theft Deterrent Module (TDM)
39	FRT WPR Fuse	25A	Wiper 1 PCV Relay
40	SEO B2 Fuse	30A	Emergency Vehicle Roof Lamp Relay (5Y0)
41	EAP Fuse	15A	PARK ENABLE Relay, ELECTRONIC ADJUSTABLE PEDALS Relay, I/P Multifunction Accessory Switch
42	HVAC BATT Fuse	10A	HVAC Control Module
43	AIRBAG IGN Fuse	10A	Inflatable Restraint Sensing and Diagnostic Module (SDM), Inflatable Restraint Passenger Air Bag ON/OFF Indicator, Inflatable Restraint I/P Module Disable Switch (C99)
44	AMP Fuse	30A	Audio Amplifier (UQA)

Fuse Block – Underhood, Device Usage – Gas			
No.	Device	Rating	Description
45	RDO Fuse	15A	Digital Radio Receiver (U2K), Radio, Rear Seat Audio (RSA) Controller (UK6)
46	MISC IGN Fuse	10A	Auxiliary Body Control Module (XBCM) (Export), Stop Lamp Switch, Transfer Case Shift Control Module (NQF/NQH), Integrated Trailer Brake Controller (ITBC) Module (JL1)
47	L/GATE RELSE Fuse	15A	Not Used
48	AIRBAG BATT Fuse	15A	Inflatable Restraint Passenger Presence System (PPS) Module, Inflatable Restraint Sensing and Diagnostic Module (SDM), Inflatable Restraint Vehicle Roll-over Sensor (ASF)
49	INFOTMNT Fuse	15A	Video Display (U42), Rear Video Display (DNU), Vehicle Communication Interface Module (VCIM) (UE1)
50	IPC Fuse	15A	Auxiliary Body Control Module (XBCM) (Export) Power Take off Relay (PTO)
51	EXP/PTO Fuse	20A	Fuel System Control Module (FSCM)
52	AUX HVAC-IGN Fuse	10A	Instrument Panel Cluster (IPC), Inside Rearview Mirror (ISRVM), Heated Steering Wheel Module (KA9)
53	CHMSL Fuse	15A	Cargo Lamp/Center High Mounted Stop Lamp (CHMSL)
54	REAR DEFOG Fuse	30A	Defogger Grid
55	HTD MIR Fuse	15A	Outside Rearview Mirror-Driver (-AN3), Outside Rearview Mirror-Passenger (-AN3)
56	SEO B1 Fuse	15A	Auxiliary Body Control Module (XBCM) (Export), Power Take Off-(PTO) Module
57	LTR Fuse	20A	Auxiliary Power Outlet-Front 1, DataLink Connector (DLC)
58	SEO/ALC Fuse	10A	Not Used

Power Distribution: Pickup - Underhood, Device Usage - Gas (cont'd)

Fuse Block - Underhood, Device Usage - Gas			
No.	Device	Rating	Description
59	HAVAC-IGN Fuse	10A	Air Temperature Actuator-Left (CJ2), Air Temperature Actuator-Right (CJ2), Air Temperature Actuator (C67), Mode Actuator, Recirculation Actuator (CJ2/C67)
60	ECM-IGN Fuse	15A	Engine Control Module (ECM), Fuel Pump Relay-Secondary (LY6-NQZ), Fuel System Control Module (FSCM)
61	FAN-1 Fuse	40A	FAN LO Relay
62	ALC/COMP Fuse	40A	Not Used
63	HEAVY DUTY ABS Fuse	60A	Electronic Brake Control Module (EBCM)
64	FAN-2 Fuse	40A	FAN HI Relay
65	ABS-1 Fuse	40A	Electronic Brake Control Module (EBCM)
66	STRTR Fuse	40A	Starter
67	STUD-1 Fuse	30A	Blunt Cut Wire, Integrated Trailer Brake Controller Solid State Relay (JL1)
68	LBEC1 Fuse	60A	AUX PWR 2 Fuse, REAR WPR Fuse, PDM Fuse, AUX PWR Fuse
69	ELEC RUN BOARD Fuse	30A	Not Used
70	WSW/HTR Fuse	60A	Windshield Washer Solvent Heater (XA7)
71	TREC Fuse	30A	Transfer Case Shift Control Module (NOF/NQH)
72	STUD-1 Fuse	40A	Trailer Wiring
73	MBEC1 Fuse	60A	DRIVER SEAT 2 Circuit Breaker, PASSENGER SEAT 1 Circuit Breaker, PWR REAR WNDW Circuit Breaker
74	HVAC BLWR Fuse	40A	Blower Motor Control Module
75	LGM Fuse	30A	Not Used

Fuse Block - Underhood, Device Usage - Gas			
No.	Device	Rating	Description
76	LBEC2 Fuse	60A	BCM Fuse, COOLED SEATS Fuses, DDM Fuse, DIM Fuse, DSM Fuse, REAR HVAC Fuse, RT STOP TRN Fuse, WSW PUMP Fuse
--	A/C COMPRSR Relay	--	A/C COMPRSR Fuse
--	ENG EXH VLV Relay	--	AXH VLV Fuse
--	FAN CONTROL Relay	--	Cooling Fan Control
--	FAN HI Relay	--	Cooling Fan-Right
--	FAN LO Relay	--	Cooling Fan-Left
--	FOG LAMP Relay	--	FOG LAMP Fuse
--	FUEL PMP Relay	--	FUEL PUMP Fuse
--	HDLP LO/HID Relay	--	LO HDLP-LT Fuse, LO HDLP-RT Fuse, DRL 2 Fuse
--	PRK LAMP Relay	--	LT PRK Fuse, RT PRK Fuse, TRLR PRK Fuse
--	PWR/TRN Relay	--	ECM/THROT CONT Fuse, ENG Fuse, INJ-A Fuse, INJ-B Fuse, 01-A SNSR Fuse, 02-B SNSR Fuse, FAN CNTRL PCB Relay, FAN HI PCB Relay, FAN LO PCB Relay
--	REAR DEFOG Relay	--	REAR DEFOG Fuse
--	RUN/CRNK Relay	--	AIRBAG Fuse, AUX HVAC-IGN Fuse, IGN Fuse, ECM-IGN Fuse, MISC IGN Fuse, SEO/ALC Fuse, TRANS IGN 1 Fuse
--	STRTR Relay	--	Starter Fuse

Power Distribution: Pickup – Underhood, Device Usage – Gas (cont'd)

Fuse Block – Underhood, Device Usage – Gas			
Note: Relays listed below are non-serviceable Printed Circuit Board (PCB) relays and are internal to the block.			
No.	Device	Rating	Description
--	BCK/UP LAMP PCB Relay	--	VEH BCK/UP Fuse, TRLR BCK/UP Fuse
--	DRL PCB Relay	--	DRL Fuse
--	FRT WASH PCB Relay	--	FRT WASH Fuse
--	HI BEAM PCB Relay	--	HI HEADLAMP-LT Fuse, HI HEADLAMP-RT Fuse
--	HORN PCB Relay	--	HORN Fuse
--	L/GATE PCB Relay	--	L/GATE RELSE Fuse
--	LOCK PCB Relay	--	LCK 2 Fuse (YE9)
--	LOCK/UNLOCK PCB Relay	--	LCK 1 Fuse, LCK 2 Fuse, UNLCK 1 Fuse, UNLCK 2 Fuse (AU3-YE9)
--	REAR WASH PCB Relay	--	REAR WASH Fuse
--	TRLR STOP LT PCB Relay	--	TRLR STOP LT Fuse
--	TRLR STOP RT PCB Relay	--	TRLR STOP RT Fuse
--	UNLOCK PCB Relay	--	DRV UNLCK Fuse, UNLCK 1 Fuse, UNLCK 2 Fuse
--	WIPER CONTROL PCB Relay	--	Windshield Wiper Motor
--	WIPER SPEED PCB Relay	--	Windshield Wiper Motor

Power Distribution: Pickup - Junction Block-Left I/P - Location

Junction Block-Left I/P, Top View

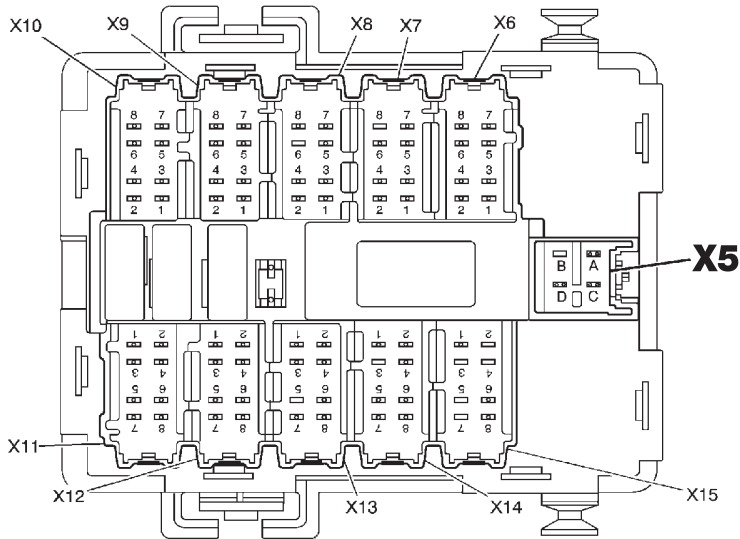

Circuit Breakers

- CB1** = RT DOORS (25A)
- CB2** = PASS SEAT 1 (25A)
- CB3** = DRIVER SEAT 2 (25A)
- CB4** = PWR REAR WNDW (25A)

Junction Block - Left I/P, Device Usage		
Device	Rating	Description
DRIVER SEAT 2 Circuit Breaker	25A	Memory Seat Module (AN3), Seat Adjuster Switch-Driver (AG1 Except AN3)
PASS SEAT 1 Circuit Breaker	25A	Seat Adjuster Switch-Passenger, Seat Lumbar Switch-Passenger (AN3)
PWR REAR WDW Circuit Breaker	25A	Not Used
RT DOORS Circuit Breaker	25A	Passenger Door Module (PDM), Window Switch-RR

Below the I/P

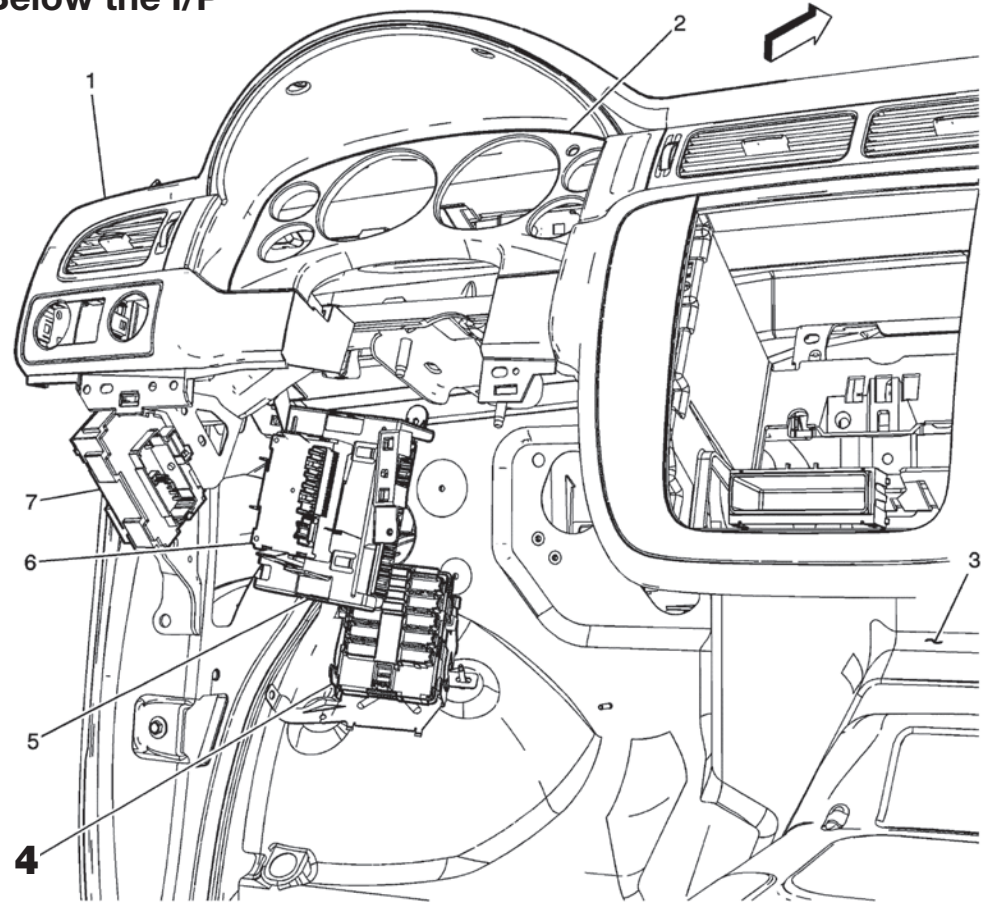

- (1) I/P Trim
- (2) I/P Cluster Trim
- (3) Floor Panel
- (4) Junction Block - Left I/P**
- (5) Body Control Module (BCM)
- (6) Transfer Case Shift Control Module
- (7) Fuse Block - I/P

Power Distribution: Pickup - Junction Block-Left I/P - Top View

Circuit Breakers

- CB1** = RT DOORS (25A)
- CB2** = PASS SEAT 1 (25A)
- CB3** = DRIVER SEAT 2 (25A)
- CB4** = PWR REAR WNDW (25A)

Junction Block - Left I/P, Device Usage		
Device	Rating	Description
DRIVER SEAT 2 Circuit Breaker	25A	Memory Seat Module (AN3), Seat Adjuster Switch-Driver (AG1 Except AN3)
PASS SEAT 1 Circuit Breaker	25A	Seat Adjuster Switch-Passenger, Seat Lumbar Switch-Passenger (AN3)
PWR REAT WDW Circuit Breaker	25A	Not Used
RT DOORS Circuit Breaker	25A	Passenger Door Module (PDM), Window Switch-RR

Junction Block-Left I/P, Top View

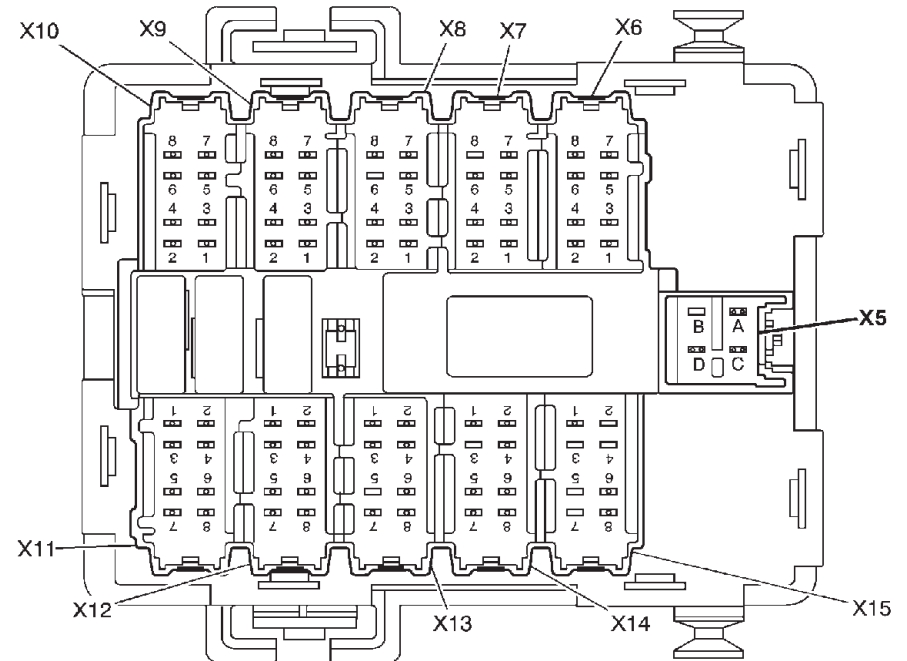

Power Distribution: Pickup - Junction Block-Left I/P-X1

Junction Block - Left I/P - X1 Connector Part Information

- OEM: 15467568
- Service: 19115661
- Description: 50-way F GT 280 Series (GY)

Junction Block - Left I/P, X1			
Pin	Wire Color	Circuit No.	Function
A1	0.5 RD/WH	4440	Battery Positive Voltage
A2	--	--	Not Used
A3	0.35 PK	239	Ignition 1 Voltage
	0.35 PK	239	Ignition 1 Voltage (NQF/NQH)
A4	0.35 PK	239	Ignition 1 Voltage
	0.8 PK	239	Ignition 1 Voltage (PTO/EXPORT)
A5	BK	2550	Ground (U42/UK6)
B1-B2	--	--	Not Used
B3	1 BK	2550	Ground
B4	0.5 GY	157	Courtesy Lamp Control
B5	--	--	Not Used
C1	0.35 PK	1639	Ignition 1 Voltage
C2	0.5 BN/WH	230	Instrument Panel Lamps Dimming Control
	0.35 BN/WH	230	Instrument Panel Lamps Dimming Control (AU3)
C3	0.5 BK	2250	Ground (U2K + Y91)
	0.5 BK	2250	Ground (UE1 + Y91)
C4	--	--	Not Used

(continued on Pg. B-19)

Junction Block-Left I/P, Bottom View

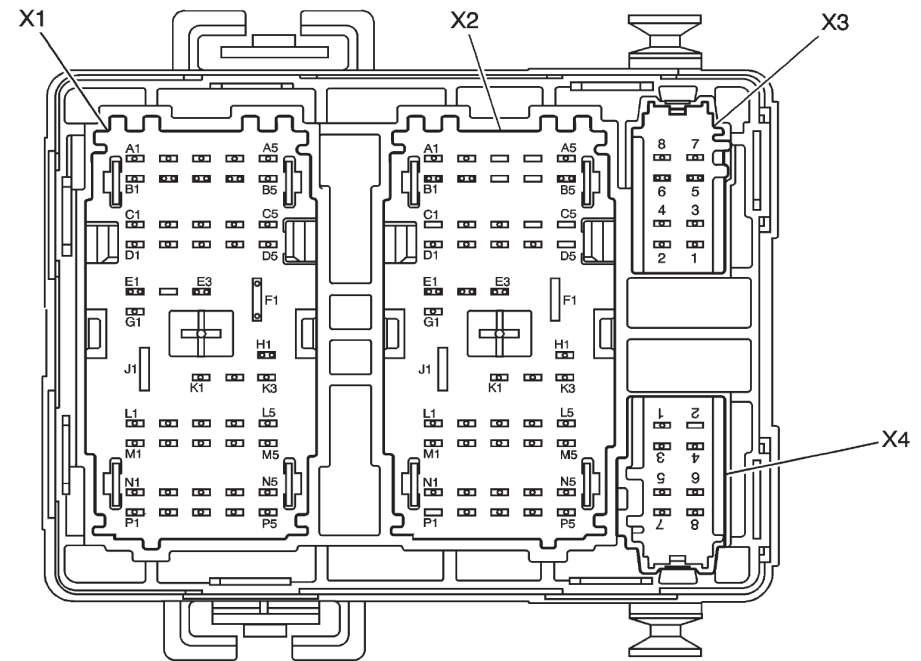

Junction X1-Terminal Parts Information

- **Pins: F1**
 - Terminal/Tray: 12110127/19
 - Core/Insulation Crimp: F/G
 - Release Tool/Test Probe: 12150860/J-35616-44 (YE)
- **Pins: D1, K2**
 - Terminal/Tray: 15304713/19
 - Core/Insulation Crimp: 4/4
 - Release Tool/Test Probe: 15315247/J-35616-4A (PU)
- **Pins: A1, A3, A4, B4, C1, C2, D3, E1, E3, H1, K1, L1, L2, L3, L4, M1, M2, M3, M4, M5, N1, N2, N3, N5, P1, P2, P3, P5**
 - Terminal/Tray: 15304711/8
 - Core/Insulation Crimp: E/A
 - Release Tool/Test Probe: 15315247/J-35616-4A (PU)
- **Pins: B3, E3, G1, K3**
 - Terminal/Tray: 15304711/8
 - Core/Insulation Crimp: 2/A
 - Release Tool/Test Probe: 15315247/J-35616-4A (PU)

Power Distribution: Pickup – Junction Block-Left I/P-Connector X1 (cont'd)

Junction Block - Left I/P - X1 (continued from Pg. B-18)

Junction Block - Left I/P, X1			
Pin	Wire Color	Circuit No.	Function
C5	0.5 YE/BK	5813	Park Enable Supply Voltage (JF4 -AN3)
D1	2 RD/WH	1340	Battery Positive Voltage (A31)
D2	--	--	Not Used
D3	0.35 BN/WH	230	Instrument Panel Lamps Dimming Control (AU3 -AN3)
	0.5 BN/WH	230	Instrument Panel Lamps Dimming Control (CF5)
D4-D5	--	--	Not Used
E1	0.5 BK/WH	1851	Ground (XA7)
E2	--	--	Not Used
E3	0.8 BK/WH	1851	Ground
	0.5 BK/WH	1851	Ground (C42/C67/CJ2)
F1	5 RD/BK	642	Battery Positive Voltage
G1	0.8 BK/WH	1851	Ground
	0.8 BK/WH	1851	Ground
H1	0.5 BK/WH	1851	Ground
	0.5 BK/WH	1851	Ground
J1	--	--	Not Used
K1	0.5 BK/WH	1851	Ground
	0.35 BK/WH	1851	Ground (C42/C67/CJ2)
K2	2 BK/WH	1851	Ground
K3	0.8 BK/WH	1851	Ground
	0.8 BK/WH	1851	Ground
L1	0.5 OG	6815	Inadvertent Power Control

Junction Block - Left I/P, X1			
Pin	Wire Color	Circuit No.	Function
L2	0.5 RD/WH	240	Battery Positive Voltage (UG1 / 5X7 / 5Y0 / TRW)
L3	0.35 PU/WH	6816	Indicator Dimming Control
L4	0.35 WH/BK	5515	Inside Air Temperature Sensor Assembly Control (CJ2)
L5	--	--	Not Used
M1	0.5 BN/WH	230	Instrument Panel Lamps Dimming Control
	0.35 BN/WH	230	Instrument Panel Lamps Dimming Control (NQF/NQH)
M2	0.35 PK	1691	Low Reference (DF5 +DL3/DR4)
M3	0.35 PU/WH	6816	Indicator Dimming Control (UD7/XA7)
M4	0.35 D-GN	734	Inside Air Temperature Sensor Signal (CJ2)
M5	0.5 OG	1054	Stop Lamp Supply Voltage (Domestic)
	0.5 OG	1054	Stop Lamp Supply Voltage (Domestic)
	0.5 L-BN	1320	Stop Lamp Supply Voltage (Export)
N1	0.35 D-GN/WH	636	Ambient Air Temperature Sensor Signal (DF5)
N2	0.35 YE	61	Low Reference (DF5)
N3	0.35 PU/WH	6816	Indicator Dimming Control (PTO)
N4	--	--	Not Used
N5	0.35 PK	1139	Ignition 1 Voltage
	0.35 PK	1139	Ignition 1 Voltage (C99)

(continued on Pg. B-20)

Power Distribution: Pickup - Junction Block-Left I/P-Connector X1 (cont'd) & X2

Junction Block - Left I/P - X1 (continued from Pg. B-19)

Junction Block - Left I/P, X1			
Pin	Wire Color	Circuit No.	Function
P1	0.35 D-BU	38	Backup Lamp Relay Control
	0.35 D-BU	38	Backup Lamp Relay Control (DF5)
P2	0.35 GY	1690	Automatic Day/Night Mirror Signal (DF5 +DL3/DR4)
P3	0.35 PU/WH	6816	Indicator Dimming Control (NQF/NQH)
P4	--	--	Not Used
P5	0.35 D-GN	6101	Low Reference

Junction Block - Left I/P - X2 Connector Part Information

- OEM: 15467567
- Service: 19149284
- Description: 50-way F GT 280 Series (BK)

Terminal Part Information

- **Pins: A1, A2, B5, C1, C3, E1, E2, E3, G1, H1, K2, K3, L3, L4, L5, M3, M5, N1, N3, N4, N5, P1, P3, P5**
- Terminal/Tray: 15304711/8
- Core/Insulation Crimp: E/A
- Release Tool/Test Probe: 15315247/J-35616-4A (PU)
- **Pins: A5, D3**
- Terminal/Tray: 15304711/8
- Core/Insulation Crimp: 2/A
- Release Tool/Test Probe: 15315247/J-35616-4A (PU)
- **Pins: B1, P4**
- Terminal/Tray: 15304713/19
- Core/Insulation Crimp: F/D
- Release Tool/Test Probe: 15315247/J-35616-4A (PU)
- **Pins: D1**
- Terminal/Tray: 15304713/19
- Core/Insulation Crimp: 4/4
- Release Tool/Test Probe: 15315247/J-35616-4A (PU)

Junction Block - Left I/P, X2			
Pin	Wire Color	Circuit No.	Function
A1	0.35 PK	739	Ignition 1 Voltage
A2	0.35 YE	43	Accessory Voltage
	0.35 YE	43	Accessory Voltage
A3-A4	--	--	Not Used
A5	0.8 RD/WH	1040	Battery Positive Voltage (D07-Y91)
B1	0.5 RD/WH	242	Battery Positive Voltage (5Y0)
B3-B4	--	--	Not Used
B5	0.5 RD/WH	3240	Battery Positive Voltage (-Y91 +UE1 +U42)
C1	0.5 YE/BK	5813	Park Enable Supply Voltage (JF4)
C2	3 BK	2550	Ground (Y91)
C3	0.5 RD/BK	340	Battery Positive Voltage
C4-C5	--	--	Not Used
D1	2 BK	1050	Ground (JF4 -AN3)
D2	--	--	Not Used
D3	0.8 RD/BK	4540	Battery Positive Voltage
	0.8 RD/BK	4540	Battery Positive Voltage (PTO/EXPORT)
D4-D5	--	--	Not Used
E1	0.5 OG/BK	5285	Adjustable Pedals Relay Rearward Control (JF4)
E2	0.5 RD/WH	740	Battery Positive Voltage (JF4)
E3	0.35 YE	6812	Out of Park Signal (JF4 -AN3)
G1	0.5 PU	5286	Adjustable Pedals Relay Forward Control (JF4)

(continued on Pg. B-21)

Power Distribution: Pickup – Junction Block-Left I/P-Connector X2 (cont'd) & X3

Junction Block - Left I/P - X2 (continued from Pg. B-20)

Junction Block - Left I/P, X2			
Pin	Wire Color	Circuit No.	Function
H1	0.35 D-GN/WH	817	Vehicle Speed Signal
	0.5 D-GN/WH	817	Vehicle Speed Signal (Y91)
K1	--	--	Not Used
K2	0.35 YE	6817	LED Backlight Dimming Control
K3	0.35 D-GN	5060	Low Speed GMLAN Serial Data
L1-L2	--	--	Not Used
L3	0.35 YE	6817	LED Backlight Dimming Control (UK3)
L4	0.35 YE	6817	LED Backlight Dimming Control
L5	0.5 TN/BK	2500	High Speed GMLAN Serial Data Bus+
	0.5 TN/BK	2500	High Speed GMLAN Serial Data Bus+
M1-M2	--	--	Not Used
M3	0.35 YE	6817	LED Backlight Dimming Control
	0.35 YE	6817	LED Backlight Dimming Control (C67/C42)
M4	--	--	Not Used
M5	0.5 TN	2501	High Speed GMLAN Serial Data Bus-
	0.5 TN	2501	High Speed GMLAN Serial Data Bus-
N1	0.35 D-BU	2307	Passenger Air Bag On Indicator Control
N2	--	--	Not Used
N3	0.35 YE	6817	LED Backlight Dimming Control (JL1)
	0.35 YE	6817	LED Backlight Dimming Control (PTO)
N4	0.35 YE	6817	LED Backlight Dimming Control
	0.35 YE	6817	LED Backlight Dimming Control (K34/KA9/UK3)

Junction Block - Left I/P, X2

Pin	Wire Color	Circuit No.	Function
N5	0.35 TN	2501	High Speed GMLAN Serial Data Bus-
N5	0.35 TN	2501	High Speed GMLAN Serial Data Bus-
P1	0.35 PU	5234	Passenger Seat Belt Indicator
P2	--	--	Not Used
P3	0.35 D-GN	2308	Passenger Air Bag Off Indicator Control
P4	3 RD/WH	3740	Battery Positive Voltage (UQA-Y91)
P5	0.5 TN/BK	2500	High Speed GMLAN Serial Data Bus+

Junction Block - Left I/P - X3 Connector Part Information

- OEM: 13516840
- Service: 19149295
- Description: 8-way F GT 280 Series (GN)

Terminal Part Information

- Terminal/Tray: 13525970/4
- Core/Insulation Crimp: E/A
- Release Tool/Test Probe: 15315247/J-35616-4A (PU)

Junction Block - Left I/P, X3

Pin	Wire Color	Circuit No.	Function
1	0.5 TN/BK	2500	High Speed GMLAN Serial Data Bus+
2	0.8 BK	1050	Ground (D07 +YE9 +AN3)
3	0.5 TN	2501	High Speed GMLAN Serial Data Bus-
4	--	--	Not Used
5	0.5 TN	2501	High Speed GMLAN Serial Data Bus-
6	3 RD/WH	3740	Battery Positive Voltage (UQA -Y91)
7	0.5 TN/BK	2500	High Speed GMLAN Serial Data Bus+
8	--	--	Not Used

Power Distribution: Pickup – Junction Block-Left I/P-Connector X4 & X5 (SPO Alarm)

Junction Block - Left I/P - X4 Connector Part Information

- OEM: 13516829
- Service: 19115667
- Description: 8-way F GT 280 Series (OG)

Terminal Part Information

- **Pins: 4**
 - Terminal/Tray: 13525969/4
 - Core/Insulation Crimp: F/D
 - Release Tool/Test Probe: 15315247/J-35616-4A (PU)
- **Pins: 3, 8**
 - Terminal/Tray: 13525970/4
 - Core/Insulation Crimp: 2/A
 - Release Tool/Test Probe: 15315247/J-35616-4A (PU)
- **Pins: 1, 2, 5, 6, 7**
 - Terminal/Tray: 13525970/4
 - Core/Insulation Crimp: E/A
 - Release Tool/Test Probe: 15315247/J-35616-4A (PU)

Junction Block - Left I/P, X4			
Pin	Wire Color	Circuit No.	Function
1	0.35 D-GN	5600	Low Speed GMLAN Serial Data (-Y91)
2	0.5 RD/WH	340	Battery Positive Voltage (-Y91)
	0.5 RD/WH	340	Battery Positive Voltage (UK6)
3	0.8 D-GN/WH	817	Vehicle Speed Signal
4	3 BK	2550	Ground (-Y91)
5	0.5 BK	2550	Ground (UE1-Y91)
	0.5 BK	2550	Ground (U2K-Y91)
6	0.5 RD/WH	3240	Battery Positive Voltage (UE1)
	0.5 RD/WH	3240	Battery Positive Voltage (U42)
7	0.5 BK	2550	Ground (U42/Y91)
	0.5 BK	2550	Ground (U42/UK6-Y91)
8	0.8 RD/WH	1040	Battery Positive Voltage (D07-Y91)

Junction Block - Left I/P - X5 SPO Alarm Connector Part Information

- OEM: 12194033
- Service: See Catalog
- Description: 4-way F Metri-Pack 280 Series (CM)

Terminal Part Information

- Terminal/Tray: See Terminal Repair Kit
- Core/Insulation Crimp: See Terminal Repair Kit
- Release Tool/Test Probe: See Terminal Repair Kit

Junction Block - Left I/P, X5 SPO Alarm			
Pin	Wire Color	Circuit No.	Function
A-C	--	--	Not Used
D	0.5 RD/WH	4540	Battery Positive Voltage

Power Distribution: Pickup - Junction Block-Left I/P-Connector X7 (JF4) & X8

Junction Block - Left I/P - X7 (JF4) Connector Part Information

- OEM: 13516836
- Service: 19149294
- Description: 8-way F GT 280 Series (OG)

Terminal Part Information

- **Pins: 1, 3, 5**
- Terminal/Tray: 13525970/4
- Core/Insulation Crimp: E/A
- Release Tool/Test Probe: 15315247/J-35616-4A (PU)
- **Pins: 2, 4**
- Terminal/Tray: 13525970/4
- Core/Insulation Crimp: 2/A
- Release Tool/Test Probe: 15315247/J-35616-4A (PU)

Junction Block - Left I/P, X7 (JF4)			
Pin	Wire Color	Circuit No.	Function
1	0.5 GY	6206	Low Reference (JF4 +AN3)
2	1 YE	5129	Adjustable Pedals Relay Rearward Control (JF4)
3	0.5 TN	6207	5-Volt Reference (JF4 +AN3)
4	1 PU	5130	Adjustable Pedals Actuator Forward Control (JF4)
5	0.5 PK	5289	Adjustable Pedal Sensor Signal (JF4 +AN3)
6-8	--	--	Not Used

Junction Block - Left I/P - X8 Connector Part Information

- OEM: 13516835
- Service: 19149293
- Description: 8-way F GT 280 Series (GN)

Terminal Part Information

- **Pins: 3**
- Terminal/Tray: 13525970/4
- Core/Insulation Crimp: 2/A
- Release Tool/Test Probe: 15315247/J-35616-4A (PU)
- **Pins: 4, 5, 6, 7**
- Terminal/Tray: 13525970/4
- Core/Insulation Crimp: E/A
- Release Tool/Test Probe: 15315247/J-35616-4A (PU)

Junction Block - Left I/P, X8			
Pin	Wire Color	Circuit No.	Function
1-2	--	--	Not Used
3	1 BK	1050	Ground
4	0.35 YE	43	Accessory Voltage (A48)
5	0.35 PU	5234	Passenger Seat Belt Indicator (AL0)
6	0.35 D-BU	2307	Passenger Air Bag On Indicator Control
7	0.35 D-GN/BK	2308	Passenger Air Bag Off Indicator Control
8	--	--	Not Used

Power Distribution: Pickup - Junction Block-Left I/P-Connector X9 & X10

Junction Block - Left I/P - X9 Connector Part Information

- OEM: 13516831
- Service: 19149289
- Description: 8-way F GT 280 Series (BK)

Terminal Part Information

- Terminal/Tray: 13525970/4
- Core/Insulation Crimp: E/A
- Release Tool/Test Probe:
15315247/J-35616-4A (PU)

Junction Block - Left I/P, X7 (JF4)			
Pin	Wire Color	Circuit No.	Function
1	0.35 PK	1639	Ignition 1 Voltage (DF5)
2	0.35	5515	Inside Air Temperature Sensor Assembly
3	0.5 OG	1054	Stop Lamp Supply Voltage Signal
4	0.35 D-GN	734	Inside Air Temperature Sensor Signal (CJ2)
5	0.35 PK	1139	Ignition 1 Voltage (AL0/C99)
6	0.5 WH/BK	158	Courtesy Lamp Supply Voltage
7	0.35 D-GN	6101	Low Reference
8	0.5 GY	157	Courtesy Lamp Control
	0.5 GY	157	Courtesy Lamp Control (Extended Cab/Crew Cab)

Junction Block - Left I/P - X10 Connector Part Information

- OEM: 13516830
- Service: 19149291
- Description: 8-way F GT 280 Series (GY)

Terminal Part Information

- Terminal/Tray: 13525970/4
- Core/Insulation Crimp: E/A
- Release Tool/Test Probe:
15315247/J-35616-4A (PU)

Junction Block - Left I/P, X10			
Pin	Wire Color	Circuit No.	Function
1	0.5 RD/WH	240	Battery Positive Voltage (TRW/5Y0/5X7/UG1)
2	0.35 OG	6815	Inadvertent Power Control
	0.35 OG	6815	Inadvertent Power Control (Extended Cab/Crew Cab - YE9)
3	0.35 PK	1691	Low Reference (DF5 +DL3/DR4)
4	0.35 BN/WH	230	Instrument Panel Lamps Dimming Control (TRW/UG1/A48)
5	0.35 YE	61	Low Reference (DF5)
6	0.35 D-GN/WH	636	Ambient Air Temperature Sensor Signal (DF5)
7	0.35 GY	1690	Automatic Day/Night Mirror Signal (DF5 +DI3/DR4)
8	0.35 D-BU	38	Backup Lamp Relay Control (DF5)

Power Distribution: Pickup – Junction Block-Left I/P – Connector X11 & X12

Junction Block - Left I/P - X11 Connector Part Information

- OEM: 13516833
- Service: 19115668
- Description: 8-way F GT 280 Series (L-GY)

Terminal Part Information

- **Pins: 1**
 - Terminal/Tray: 13525969/4
 - Core/Insulation Crimp: 4/4
 - Release Tool/Test Probe: 15315247/J-35616-4A (PU)
- **Pins: 2**
 - Terminal/Tray: 13525969/4
 - Core/Insulation Crimp: F/D
 - Release Tool/Test Probe: 15315247/J-35616-4A (PU)
- **Pins: 4, 6, 8**
 - Terminal/Tray: 13525970/4
 - Core/Insulation Crimp:
 - Release Tool/Test Probe: 15315247/J-35616-4A (PU)
- **Pins: 7**
 - Terminal/Tray: 13525970/4
 - Core/Insulation Crimp: 2/A
 - Release Tool/Test Probe: 15315247/J-35616-4A (PU)

Junction Block - Left I/P, X11			
Pin	Wire Color	Circuit No.	Function
1	2 RD/WH	1340	Battery Positive Voltage (Crew Cab +A31/Extended Cab +ABV)
2	3 RD/WH	1440	Battery Positive Voltage
3	--	--	Not Used
4	0.5 BN/WH	230	Instrument Panel Lamps Dimming Control (Crew Cab +31/Extended Cab +ABV)
	0.5 BN/WH	230	Instrument Panel Lamps Dimming Control (Crew Cab +31/Extended Cab +ABV)
5	--	--	Not Used
6	0.35 PK	1139	Ignition 1 Voltage
7	0.8 RD/WH	4440	Battery Positive Voltage (-AL0)
	0.5 RD/WH	4440	Battery Positive Voltage (AL0)
	0.35 RD/WH	4440	Battery Positive Voltage (AL0)
8	0.5 RD/WH	4440	Battery Positive Voltage (ASF)

Junction Block - Left I/P - X12 Connector Part Information

- OEM: 13516834
- Service: 19149292
- Description: 8-way F GT 280 Series (BN)

Terminal Part Information

- **Pins: 1, 2, 8**
 - Terminal/Tray: 13525969/4
 - Core/Insulation Crimp: F/D
 - Release Tool/Test Probe: 15315247/J-35616-4A (PU)
- **Pins: 6**
 - Terminal/Tray: 13525970/4
 - Core/Insulation Crimp: 2/A
 - Release Tool/Test Probe: 15315247/J-35616-4A (PU)

Junction Block - Left I/P, X12			
Pin	Wire Color	Circuit No.	Function
1	3 RD/WH	5040	Battery Positive Voltage (AN3)
2	3 RD/WH	3440	Battery Positive Voltage (A48)
3-5	--	--	Not Used
6	1 WH/BK	158	Courtesy Lamp Supply Voltage
7	--	--	Not Used
8	3 BK	2550	Ground

Power Distribution: Pickup – Junction Block-Left I/P-Connector X13 & X14

Junction Block - Left I/P - X13 Connector Part Information

- OEM: 13516832
- Service: 19149290
- Description: 8-way F GT 280 Series (D-BU)

Terminal Part Information

- **Pins: 1, 2**
- Terminal/Tray: 13525970/4
- Core/Insulation Crimp: 2/A
- Release Tool/Test Probe: 15315247/J-35616-4A (PU)
- **Pins: 3, 4, 5, 6, 7, 8**
- Terminal/Tray: 13525970/4
- Core/Insulation Crimp: E/A
- Release Tool/Test Probe: 15315247/J-35616-4A (PU)

Junction Block - Left I/P, X13			
Pin	Wire Color	Circuit No.	Function
1	1 PU	5130	Adjustable Pedals Relay Forward Control (JF4 +AN3)
2	1 YE	5129	Adjustable Pedals Relay Rearward Control (JF4 +AN3)
3	0.35 PU	5286	Adjustable Pedals Relay Forward Control (JF4 +AN3)
4	0.35 OG/BK	5825	Adjustable Pedals Relay Rearward Control (JF4 +AN3)
5	0.5 TN	6207	Memory Sensor High Reference (JF4 +AN3)
6	0.5 PK	5289	Adjustable Pedal Sensor Signal (JF4 +AN3)
7	0.5 GY	6206	Low Reference (JF4 +AN3)
8	0.35 YE	43	Accessory Voltage (A31 -AN3/DL3)
	0.35 YE	43	Accessory Voltage (A31 -AN3/DL3)
	0.35 PU/WH	6205	12-Volt Reference (JF4 +AN3)

Junction Block - Left I/P - X14 Connector Part Information

- OEM: 13516837
- Service: See Catalog
- Description: 8-way F GT 280 Series (BK)

Terminal Part Information

- Terminal/Tray: See Terminal Repair Kit
- Core/Insulation Crimp: See Terminal Repair Kit
- Core/Insulation Crimp: See Terminal Repair Kit

Junction Block - Left I/P, X14			
Pin	Wire Color	Circuit No.	Function
1	0.5 BK	1050	Ground (5Y0/5X7)
2-4	--	--	Not Used
5	3 RD/WH	2340	Battery Positive Voltage (5Y0)
6-7	--	--	Not Used
8	0.5 YE	43	Accessory Voltage (9L4)

Power Distribution: Pickup – Junction Block-Right I/P-Fuse Block Location View

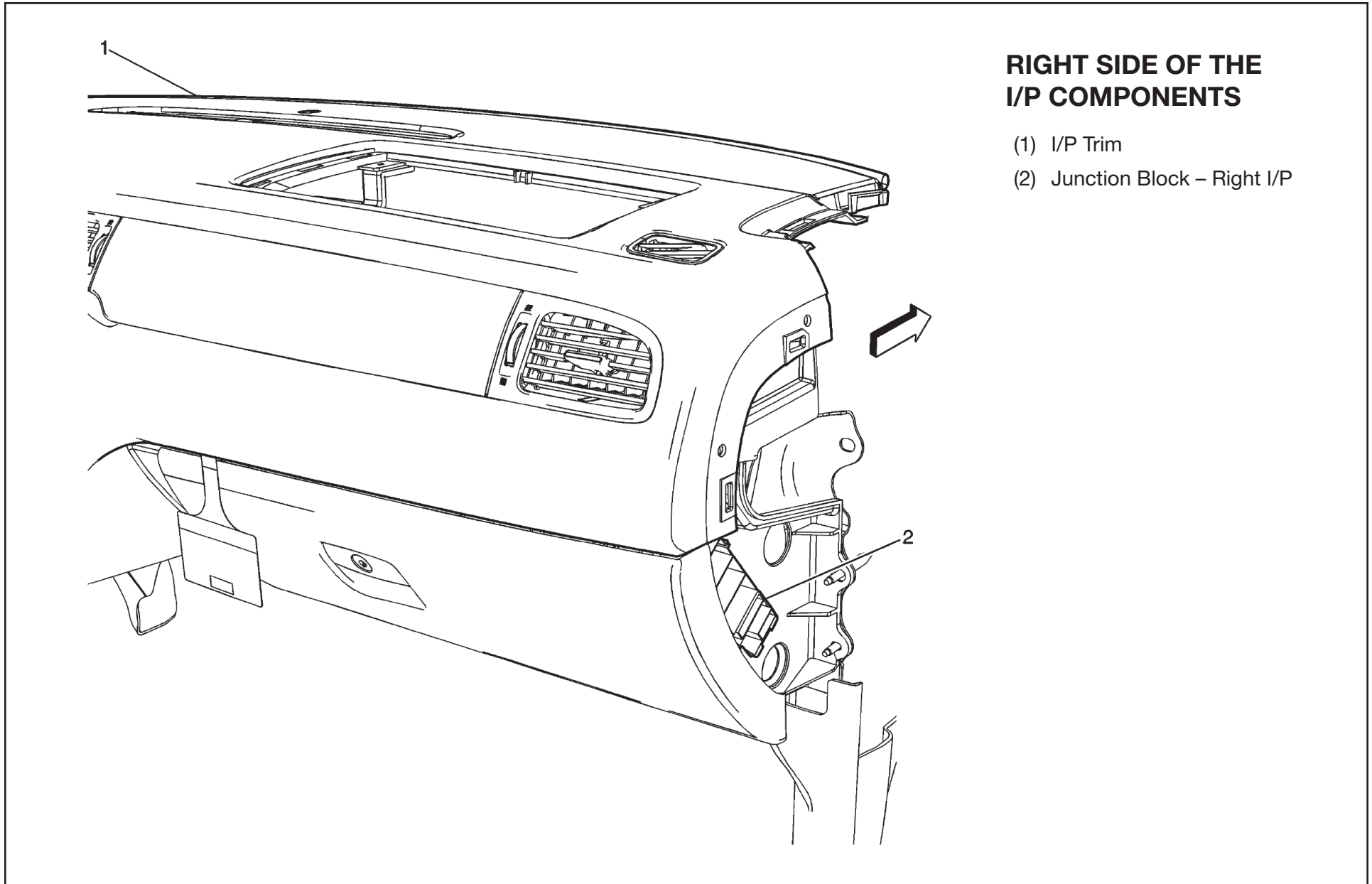

Power Distribution: Pickup - Junction Block-Right I/P-Connector X1

Junction Block - Right I/P - X1 Connector Part Information

- OEM: 15489487
- Service: See Catalog
- Description: 40-way F (BK)

Terminal Part Information

- **Pins: 2A4, 2B4, 3B1, 5A, 5C, 5D, 5E, 5F**
 - Terminal/Tray: 15304722/8
 - Core/Insulation Crimp: E/C
 - Release Tool/Test Probe: 15315247/J-35616-5 (PU)
- **Pins: 3A1, 3A4**
 - Terminal/Tray: 15304724/8
 - Core/Insulation Crimp: 2/A
 - Release Tool/Test Probe: See Terminal Repair Kit
- **Pins: 2A2, 2A3, 2B3, 2B6, 2B7, 3A7, 4A1, 4A2, 4A3, 4A4, 4A5, 4A6, 4A7, 4B2, 4B3, 4B5, 4B6, 5B**
 - Terminal/Tray: 15304724/8
 - Core/Insulation Crimp: See Terminal Repair Kit
 - Release Tool/Test Probe: See Terminal Repair Kit
- **Pins: 2B1, 3B4**
 - Terminal/Tray: 15304724/8
 - Core/Insulation Crimp: C/D
 - Release Tool/Test Probe: See Terminal Repair Kit
- **Pins: 6A**
 - Terminal/Tray: 12066493/3
 - Core/Insulation Crimp: B/G
 - Release Tool/Test Probe: 12094430/J-35616-43 (RD)
- **Pins: 6B**
 - Terminal/Tray: 12066493/3
 - Core/Insulation Crimp: F/G
 - Release Tool/Test Probe: 12094430/J-35616-43 (RD)

(continued on Pg. B-28)

Junction Block-Right I/P (Wire Entry), Top View

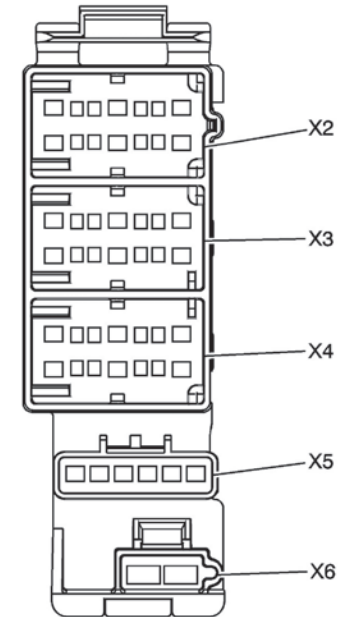

Junction Block-Right I/P (Wire Entry), Bottom View



Power Distribution: Pickup – Junction Block-Right I/P-Connector X1 (cont'd)

Junction Block - Right I/P - X1 Connector Part Information

(continued from Pg. B-27)

Junction Block - Right I/P, X1			
Pin	Wire Color	Circuit No.	Function
2A1	--	--	Not Used
2A2	0.35 TN	481	Outside Moisture Signal 1 (CE1)
2A3	0.35 L-GN	482	Outside Moisture Signal 2 (CE1)
2A4	0.35 WH	2283	Ignition Voltage (CE1)
	0.35 WH	2283	Ignition Voltage (NQH/NQF +CE1)
2A5-2A6	--	--	Not Used
2A7	--	--	Ground Bus
2B1	0.35 RD/WH	3140	Battery Positive Voltage (CF5/TRW)
2B2	0.5 BN	2509	Left Front Park Lamps Supply Voltage (U01)
2B3	0.35 YE	43	Accessory Voltage (CF5)
2B4	0.5 BN/WH	230	Instrument Panel Lamp Dimming Control (CF5)
2B5	0.5 WH	5990	Emergency Lamp Switch Signal (5Y0/5X7)
2B6	0.5 BK	1050	Ground
2B7	0.35 OG	300	Ignition 3 Voltage (Export w/CF5)
3A1	0.5 D-GN	117	Right Front Speaker Output (-)
3A2	0.5 L-GN	200	Right Front Speaker Output (+)
3A3	0.35 BK	1850	Ground

(continued from column at left)

Junction Block - Right I/P, X1			
Pin	Wire Color	Circuit No.	Function
3A4	0.8 D-BU/WH	1315	Right Front Turn Signal Lamp Supply Voltage (DL3/DPN)
	0.8 D-BU/WH	1315	Right Front Turn Signal Lamp Supply Voltage (DL3/DPN)
	0.35 L-BU	224	Passenger Door Lock Switch Lock Signal (AU3-YE9)
3A5	0.35 TN/WH	746	Right Front Door Ajar Switch Signal (-AN3/DL3)
3A6	0.8 GY	295	Door Lock Actuator Lock Control (AU3 -AN3/DL3)
3A7	3 BK	1050	Ground
3B1	0.35 D-GN	5060	Low Speed GMLAN Serial Data (YE9 +AN3/DL3)
3B2	0.8 RD/WH	240	Battery Positive Voltage
3B3	0.8 TN	294	Door Lock Actuator Unlock Control (AU3 -AN3/DL3)
3B4	2 RD/WH	1340	Battery Positive Voltage (A31)
	0.35 D-BU	245	Passenger Door Lock Switch Unlock Signal (AU3 -YE9)
3B5	0.35 BN/WH	230	Instrument Panel Lamp Dimming Control (AU3)
3B6	0.35 OG	5922	Passenger Door Open Signal (-AN3/DL3)
3B7	--	--	Ground Bus
4A1	0.35 GY	598	5-Volt Reference
4A2	0.35 TN	520	Lower Right Air Temperature Sensor Signal (CJ2)

(continued on Pg. B-29)

Power Distribution: Pickup - Junction Block-Right I/P-Connector X1 (cont'd)

(continued from Pg. B-28)

Junction Block - Right I/P, X1			
Pin	Wire Color	Circuit No.	Function
4A3	0.35 TN	518	Lower Left Air Temperature Sensor Signal (CJ2)
4A4	0.35 YE	1791	Low Reference
4A5	0.35 PU	1838	Recirculation Door Position Signal (CJ2)
4A6	0.35 GY/BK	754	Blower Motor Speed Control
4A7	3 BK	1050	Ground
4B1	--	--	5-Volt Reference Bus
4B2	0.35 D-BU	1199	Air Temperature Door Control
4B3	0.35 TN	2273	Mode Door Control
4B4	--	--	Low Reference Bus
4B5	0.35 YE/BK	713	Defrost/Heater Mode Valve Position Sensor Signal

(continued from column at left)

Junction Block - Right I/P, X1			
Pin	Wire Color	Circuit No.	Function
4B6	0.35 L-BU	733	Air Temperature Door Position Signal
4B7	--	--	Ground Bus
5A	0.35 D-GN	6101	Low Reference
5B	0.35 PK	839	Ignition 1 Voltage
	0.35 PK	839	Ignition 1 Voltage
5C	0.35 PK	839	Ignition 1 Voltage
5D	0.35 D-BU	1646	Auxiliary Air Temperature Door Position Signal
5E	0.35 WH/BK	1236	Auxiliary Air Temperature Door Control
5F	0.35 D-GN	1614	Recirculation Door Control
6A	5 RD/BK	542	Battery Positive Voltage
6B	3 BK	1050	Ground
	3 BK	1050	Ground

Power Distribution: Pickup – Junction Block-Right I/P-Connector X2

Junction Block - Right I/P - X2 Connector Part Information

- OEM: 15467621
- Service: 19115663
- Description: 14-way F GT 150/280 Series (GY)

Terminal Part Information

- **Pins: B2, B3**
 - Terminal/Tray: 12191812/19
 - Core/Insulation Crimp: E/C
 - Release Tool/Test Probe: 15315247/J-35616-2A (GY)
- **Pins: A7, B4**
 - Terminal/Tray: 15304711/8
 - Core/Insulation Crimp: E/A
 - Release Tool/Test Probe: 15315247/J-35616-4A (PU)
- **Pins: A7, B1**
 - Terminal/Tray: 15304713/19
 - Core/Insulation Crimp: F/D
 - Release Tool/Test Probe: 15315247/J-35616-4A (PU)

Junction Block - Right I/P, X2			
Pin	Wire Color	Circuit No.	Function
A1	--	--	Not Used
A2	0.35 TN	481	Outside Moisture Signal 1 (CE1)
A3	0.35 L-GN	482	Outside Moisture Signal 2 (CE1)
A4	0.35 WH	2283	Ignition Voltage (CE1)

(continued from column at left)

Junction Block - Right I/P, X2			
Pin	Wire Color	Circuit No.	Function
A5-A6	--	--	Not Used
A7	3 BK	1050	Ground (CF5/TRW)
	0.5 BK	1050	Ground (U01)
B1	3 RD/WH	3140	Battery Positive Voltage (CF5/TRW)
B2	0.5 BN	2509	Left Front Park Lamps Supply Voltage (U01)
B3	0.35 YE	43	Accessory Voltage (CF5)
B4	0.5 BN/WH	230	Instrument Panel Lamps Dimming Control (CF5)
B5	0.5 WH	5990	Emergency Lamp Switch Signal (5Y0/5X7)
B6	0.35 BK	1050	Ground (CE1)
B7	--	--	Not Used

Power Distribution: Pickup – Junction Block-Right I/P-Connector X3

Junction Block - Right I/P - X3 Connector Part Information

- OEM: 15467622
- Service: 19115664
- Description: 14-way F GT 150/280 Series (L-GY)

Terminal Part Information

- **Pins: A1**
 - Terminal/Tray: 15304711/8
 - Core/Insulation Crimp: 2/A
 - Release Tool/Test Probe: 15315247/J-35616-4A (PU)
- **Pins: A2, A6, B2, B3**
 - Terminal/Tray: 12191812/19
 - Core/Insulation Crimp: C/A
 - Release Tool/Test Probe: 15315247/J-35616-2A (GY)
- **Pins: A3, A5, B5, B6**
 - Terminal/Tray: 12191812/19
 - Core/Insulation Crimp: E/C
 - Release Tool/Test Probe: 15315247/J-35616-2A (GY)
- **Pins: A4, B1, B4**
 - Terminal/Tray: 15304711/8
 - Core/Insulation Crimp: E/A
 - Release Tool/Test Probe: 15315247/J-35616-4A (PU)
- **Pins: A7**
 - Terminal/Tray: 15304713/19
 - Core/Insulation Crimp: F/D
 - Release Tool/Test Probe: 15315247/J-35616-4A (PU)
- **Pins: B4**
 - Terminal/Tray: 15304713/19
 - Core/Insulation Crimp 4/4
 - Release Tool/Test Probe: 15315247/J-35616-4A (PU)

Junction Block - Right I/P, X3			
Pin	Wire Color	Circuit No.	Function
A1	0.8 D-GN	117	Right Front Speaker Output (-)
A2	0.8 L-GN	200	Right Front Speaker Output (+)
A3	0.35 BK	1850	Ground (-AN3/DL3)
A4	0.5 D-BU/WH	1315	Right Front Turn Signal Lamp Supply Voltage (DL3/DPN)
	0.35 L-BU	244	Passenger Door Lock Switch Lock Signal (AU3 -YE9)

(continued from column at left)

Junction Block - Right I/P, X3			
Pin	Wire Color	Circuit No.	Function
A5	0.35 TN/WH	746	Right Front Door Ajar Switch Signal (-AN3/DL3)
A6	1 GY	295	Door Lock Actuator Lock Control (AU3 -AN3/DL3)
A7	3 BK	1050	Ground (A31/AN3/DL3/DL8/DPN)
B1	0.35 D-GN	5060	Low Speed GMLAN Serial Data (AN3/DL3)
B2	0.8 RD/WH	240	Battery Positive Voltage
B3	1 TN	294	Door Lock Actuator Unlock Control (AU3 -AN3/DL3)
B4	2 RD/WH	1340	Battery Positive Voltage (A31)
	0.35 D-BU	245	Passenger Door Lock Switch Unlock Signal (AU3 -YE9)
B5	0.35 BN/WH	230	Instrument Panel Lamps Dimming Control (AU3 -AN3/DL3)
B6	0.35 OG	5922	Non-Driver Door Open Switch Signal (-AN3/DL3)
B7	--	--	Not Used

Power Distribution: Pickup – Junction Block-Right I/P-Connector X4

Junction Block - Right I/P - X4 Connector Part Information

- OEM: 15467620
- Service: 19115662
- Description: 14-way F GT 150/280 Series (BK)

Terminal Part Information

- Pins: **A1, A4, B1, B4**
- Terminal/Tray: 15304711/8
- Core/Insulation Crimp: 2/A
- Release Tool/Test Probe: 15315247/J-35616-4A (PU)
- Pins: **A2, A3, A5, A6, B2, B3, B5, B6**
- Terminal/Tray: 12191812/19
- Core/Insulation Crimp: E/C
- Release Tool/Test Probe: 15315247/J-35616-2A (GY)

Junction Block - Right I/P, X4			
Pin	Wire Color	Circuit No.	Function
A1	0.35 L-BU/BK	598	5-Volt Reference
	0.35 L-BU/BK	598	5-Volt Reference (C67/CJ2)
A2	0.35 TN	520	Lower Right Air Temperature Sensor Signal (CJ2)
A3	0.35 TN	518	Lower Left Air Temperature Sensor Signal (CJ2)

(continued from column at left)

Junction Block - Right I/P, X4			
Pin	Wire Color	Circuit No.	Function
A4	0.35 YE	1791	Low Reference
	0.35 YE	1791	Low Reference (C67/CJ2)
A5	0.35 PU	1838	Recirculation Door Position Signal (CJ2)
A6	0.35 PU/WH	754	Blower Motor Speed Control
A7	--	--	Not Used
B1	0.35L-BU/WH	598	5-Volt Reference
	0.35L-BU/WH	598	5-Volt Reference (CJ2)
B2	0.35 D-BU	1199	Left Air Temperature Door Control (CJ2)
B3	0.35 TN	2273	Mode Door Control
B4	0.35 YE	1791	Low Reference
	0.35 YE	1791	Low Reference (CJ2)
B5	0.35 L-GN	713	Mode Door Position Signal
B6	0.35 L-BU	733	Left Air Temperature Door Position Signal (CJ2)
B7	--	--	Not Used

Power Distribution: Pickup - Junction Block-Right I/P-Connector X5 & X6

Junction Block - Right I/P - X5 Connector Part Information

- OEM: 15326900
- Service: 15606380
- Description: 6-way F GT 280 Series (BK)

Terminal Part Information

- **Pins: A-C**
- Terminal/Tray: 15304711/8
- Core/Insulation Crimp: 2/A
- Release Tool/Test Probe: 15315247/J-35616-4A (PU)
- **Pins: D-F**
- Terminal/Tray: 15304711/8
- Core/Insulation Crimp: E/A
- Release Tool/Test Probe: 15315247/J-35616-4A (PU)

Junction Block - Right I/P, X4			
Pin	Wire Color	Circuit No.	Function
A	0.35 D-GN	6101	Low Reference (CJ2)
	0.35 D-GN	6101	Low Reference (CJ2)
B	0.35 BN	839	Ignition 1 Voltage
	0.35 BN	839	Ignition 1 Voltage (C67/CJ2)
C	0.35 BN	839	Ignition 1 Voltage
	0.35 BN	839	Ignition 1 Voltage (CJ2)
D	0.35 D-BU	1646	Right Air Temperature Door Position Signal
E	0.35 WH/BK	1236	Right Air Temperature Door Control
F	0.35 D-GN	1614	Recirculation Door Control (C67/CJ2)

Junction Block - Right I/P - X6 Connector Part Information

- OEM: 12129939
- Service: 15306380
- Description: 2-way F Metri-Pack Series (BK)

Terminal Part Information

- Terminal/Tray: 12084590/3
- Core/Insulation Crimp: F/G
- Release Tool/Test Probe: 12094430/J-35616-42 (RD)

Junction Block - Right I/P, X6			
Pin	Wire Color	Circuit No.	Function
A	3 RD	542	Battery Positive Voltage
B	3 BK	1050	Ground

Power Distribution: Pickup – Junction Block-Rear Lamps – Connector X1

Junction Block - Rear Lamps - X1 Connector Part Information

- OEM: 15317304
- Service: 15306114
- Description: 8-way F GT 280 Sealed (BU)

Terminal Part Information

- Pins: A, C, D, G, H
- Pins: B, E
- Terminal/Tray: 15304716/8
- Terminal/Tray: 15304717/8
- Core/Insulation Crimp: 2/1
- Core/Insulation Crimp: 4/1
- Release Tool/Test Probe: 15315247/J-35616-4A (PU)
- Release Tool/Test Probe: 15315247/J-35616-4A (PU)

Junction Block - Rear Lamps, X1			
Pin	Wire Color	Circuit No.	Function
A	0.5 YE	18	Left Rear Stop/Turn Lamp Supply Voltage
B	2 BK	2150	Ground
C	0.8 L-GN	24	Backup Lamp Supply Voltage
D	0.5 BN	2609	Right Rear Park Lamps Supply Voltage
E	2 BK	1750	Ground
F	--	--	Not Used
G	0.8 BN	2509	Left Rear Park Lamp Supply Voltage
H	0.5 D-GN	19	Right Rear Stop/Turn Lamp Supply Voltage

Junction Block-Rear Lamps

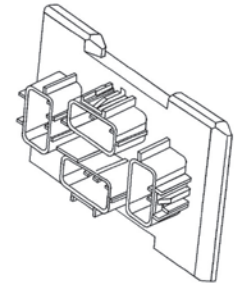
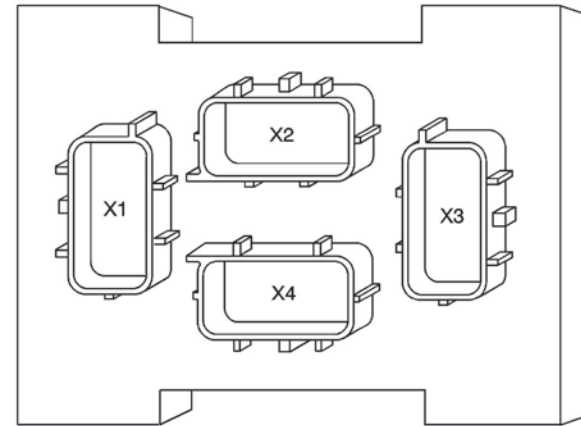

Junction Block-Rear Lamps X1

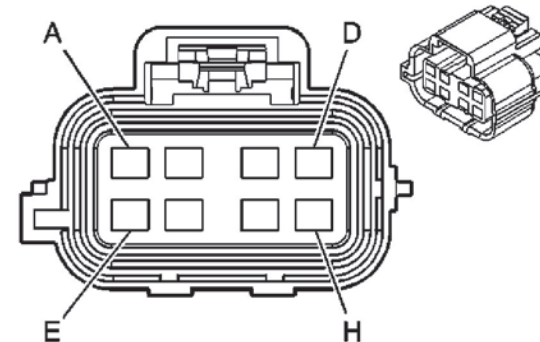

Power Distribution: Pickup – Junction Block-Rear Lamps – Connector X2 & X3

Junction Block - Rear Lamps - X2 Connector Part Information

- OEM: 15317305
- Service: 15306338
- Description: 8-way F GT 280 Sealed (GY)

Terminal Part Information

- | | |
|--|--|
| • Pins: A, C, D, G, H | • Pins: B, E |
| • Terminal/Tray: 15304716/8 | • Terminal/Tray: 15304717/8 |
| • Core/Insulation Crimp: 2/1 | • Core/Insulation Crimp: 4/1 |
| • Release Tool/Test Probe:
15315247/J-35616-4A (PU) | • Release Tool/Test Probe:
15315247/J-35616-4A (PU) |

Junction Block - Rear Lamps, X2			
Pin	Wire Color	Circuit No.	Function
A-B	--	--	Not
C	0.8 BK	1750	Ground
D	--	--	Not Used
E	0.8 BN	2509	Left Rear Park Lamps Supply Voltage
F	0.8 L-GN	24	Backup Lamp Supply Voltage
G	--	--	Not Used
G	0.8 BN	2509	Left Rear Park Lamp Supply Voltage
H	0.8 YE	18	Left Rear Stop/Turn Lamp Supply Voltage

Junction Block - Rear Lamps - X3 Connector Part Information

- OEM: 15317308
- Service: 15306135
- Description: 8-way F GT 280 Sealed 5.2 (BN)

Terminal Part Information

- Terminal/Tray: 15304716/8
- Core/Insulation Crimp: E/1
- Release Tool/Test Probe:
15315247/J-35616-4A (PU)

Junction Block - Rear Lamps, X3			
Pin	Wire Color	Circuit No.	Function
A	0.5 BN	2609	Right Rear Park Lamps Supply Voltage
B	0.5 BN	2609	Right Rear Park Lamps Supply Voltage (R05)
C	0.5 BK	1750	Ground (R05)
D	0.5 BK	1750	Ground (R05)
E	0.5 BK	1750	Ground
F	0.5 BN	2509	Left Rear Park Lamps Supply Voltage (R05)
G	0.5 BN	2509	Left Rear Park Lamps Supply Voltage
H	0.5 BK	1750	Ground

Power Distribution: Pickup – Junction Block-Rear Lamps – Connector X4

Junction Block - Rear Lamps - X4 Connector Part Information

- OEM: 15317306
- Service: 15306339
- Description: 8-way F GT 280 Sealed 5.2 (BK)

Terminal Part Information

- Terminal/Tray: 15304716/8
- Core/Insulation Crimp: E/1
- Release Tool/Test Probe:
15315247/J-35616-4A (PU)

Junction Block - Rear Lamps, X4			
Pin	Wire Color	Circuit No.	Function
A	0.8 BK	2150	Ground
B	0.8 BN	2609	Right Rear Park Lamps Supply Voltage
C-D	--	--	Not Used
E	0.8 L-GN	24	Backup Lamp Supply Voltage
F	0.8 D-GN	19	Right Rear Stop/Turn Lamp Supply Voltage
G-H	--	--	Not Used

Ground Distribution: Diesel Ground – 2007 Chevrolet Silverado - 4WD

Left Side of Engine (Diesel)

- (1) Fuel Injector 2
- (2) Turbocharger Vane Position Sensor
- (3) Fuel Injector 4
- (4) Fuel Rail Pressure Sensor
- (5) Fuel Injector 6
- (6) Fuel Injector 8
- (7) Glow Plug 8
- (8) Glow Plug 6
- (9) Engine Oil Level Switch
- (10) Engine Oil Pressure (EOP) Sensor
- (11) Glow Plug 4
- (12) G106
- (13) G102
- (14) Glow Plug 2

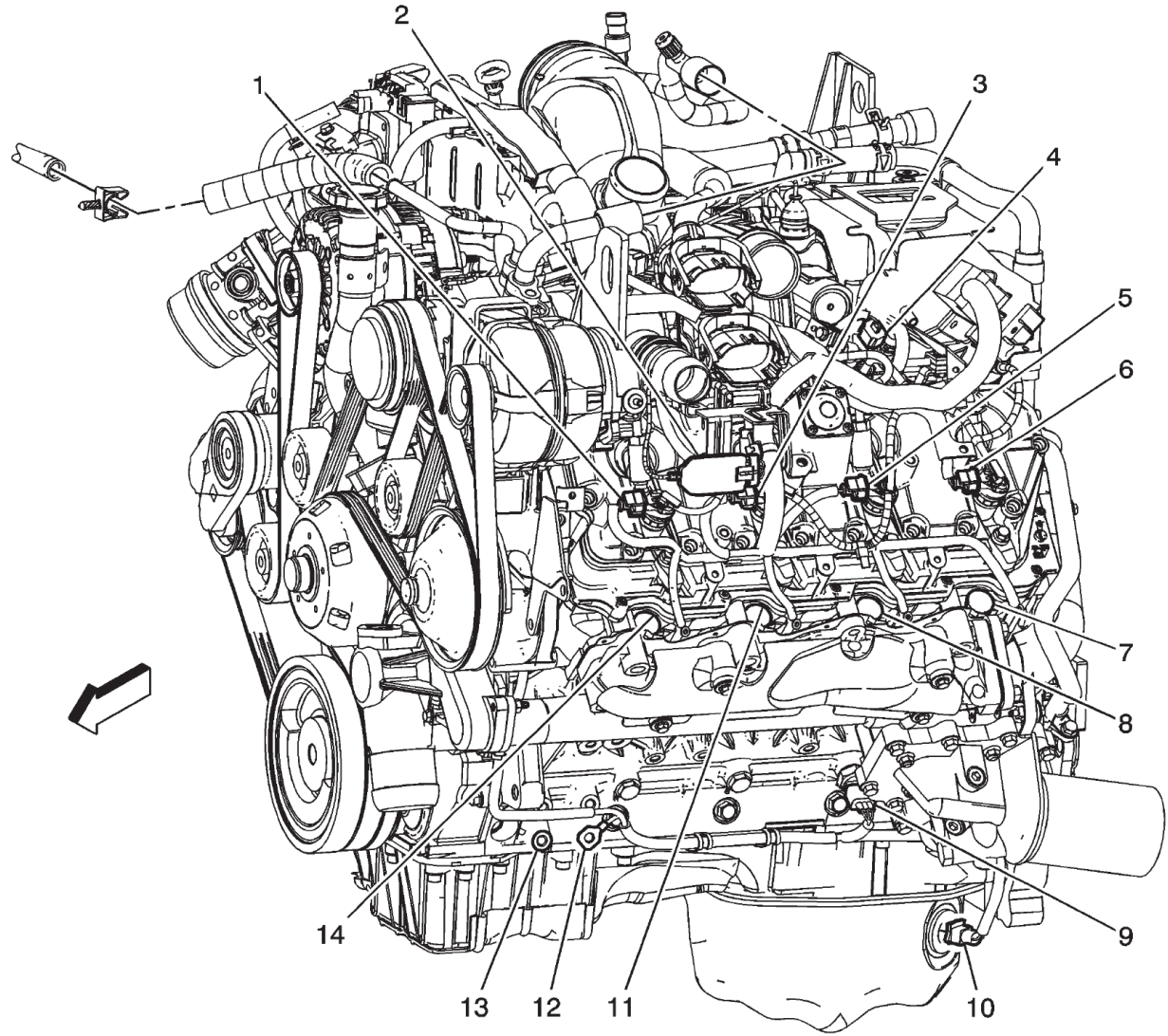

1871192

Ground Distribution: Diesel Ground - 2007 Chevrolet Silverado - 4WD

Right Side of Engine (Diesel)

- (1) Fuel Injector 7
- (2) Fuel Injector 5
- (3) Fuel Injector 3
- (4) Exhaust Gas Recirculation (EGR) Valve
- (5) Fuel Injector 1
- (6) Mass Air Flow (MAF)/Intake Air Temperature (IAT) Sensor
- (7) Intake Air Valve
- (8) Crankshaft Position (CKP) Sensor
- (9) Glow Plug 1
- (10) G103
- (11) G105
- (12) Block Heater
- (13) Glow Plug 3
- (14) Glow Plug 5
- (15) Wear In Fuel Sensor
- (16) Starter
- (17) Glow Plug 7

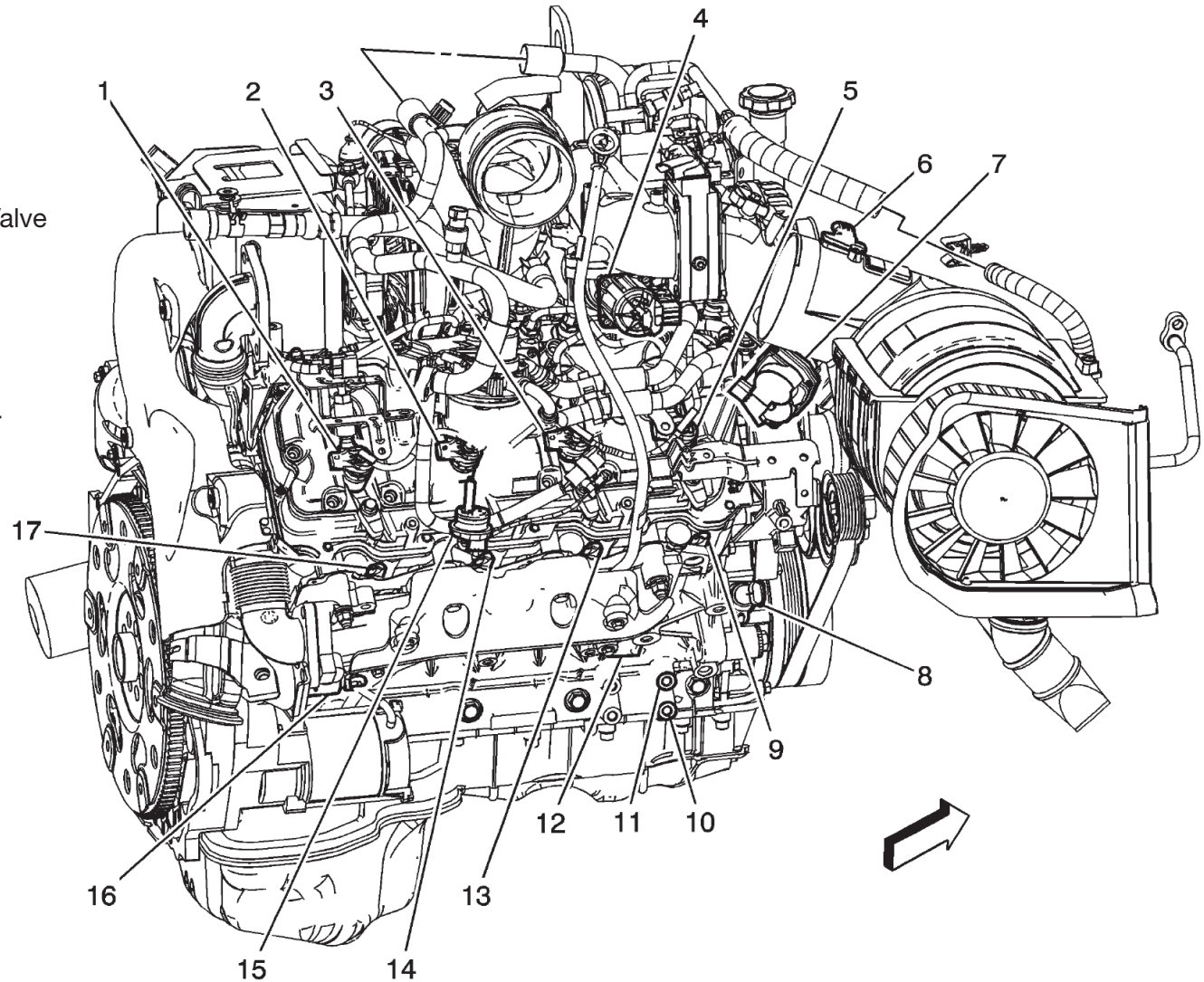

1871149

Ground Distribution: G107, G108, F110, G111, and G104 Grounds

G107, G108, G110, G111, and G104

- (1) G107 (4.3L)
- (2) G111 (XA7)
- (3) G108
- (4) G110 (XA7)
- (5) Brake Booster Assembly
- (6) Fuse Block-Underhood
- (7) G104 (6A6)

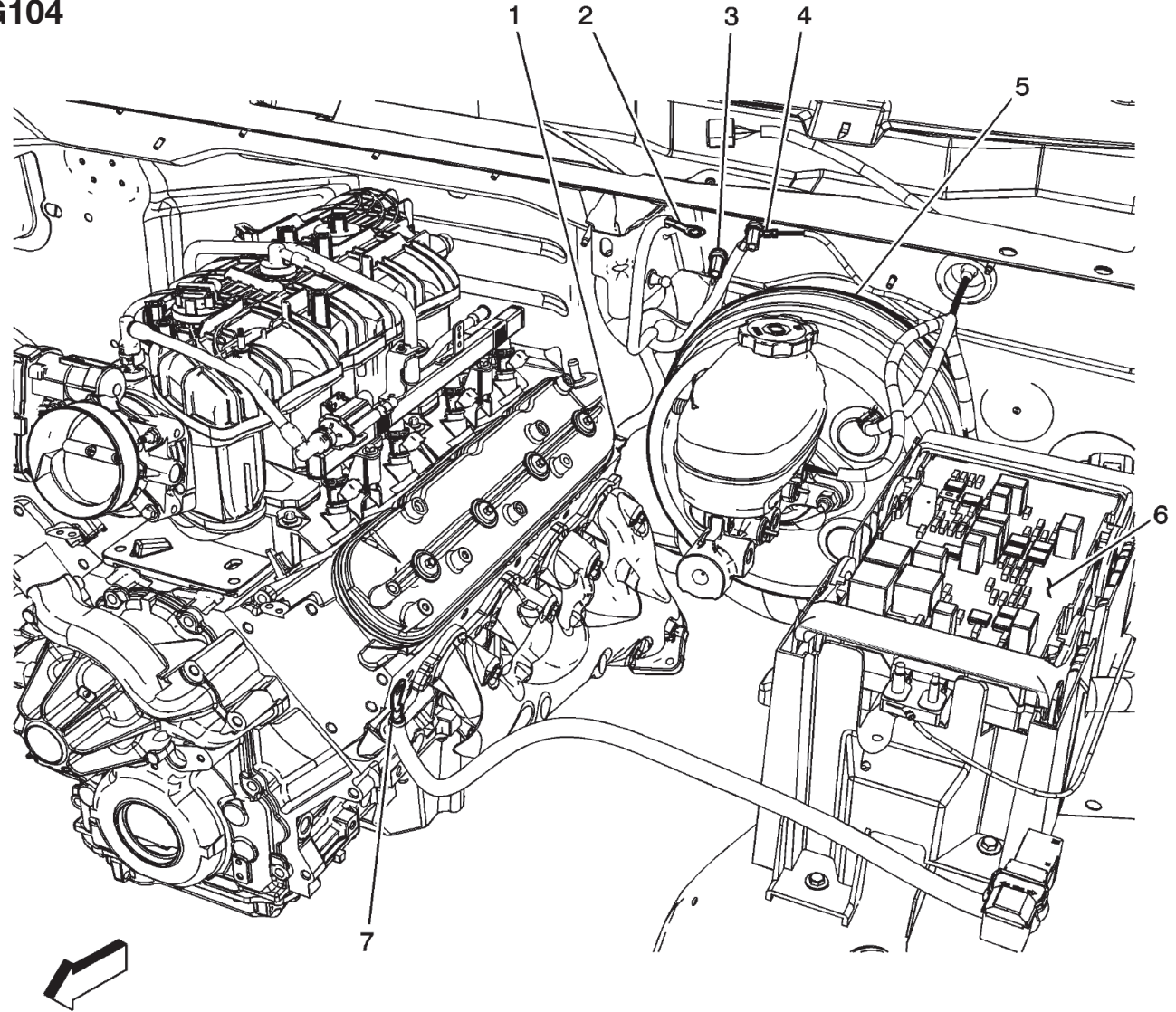

1888648

Ground Distribution: G301, G302, G303, and G304 Grounds

G301, G302, G303 and G304

- (1) G303
- (2) G302
- (3) G304
- (4) G301

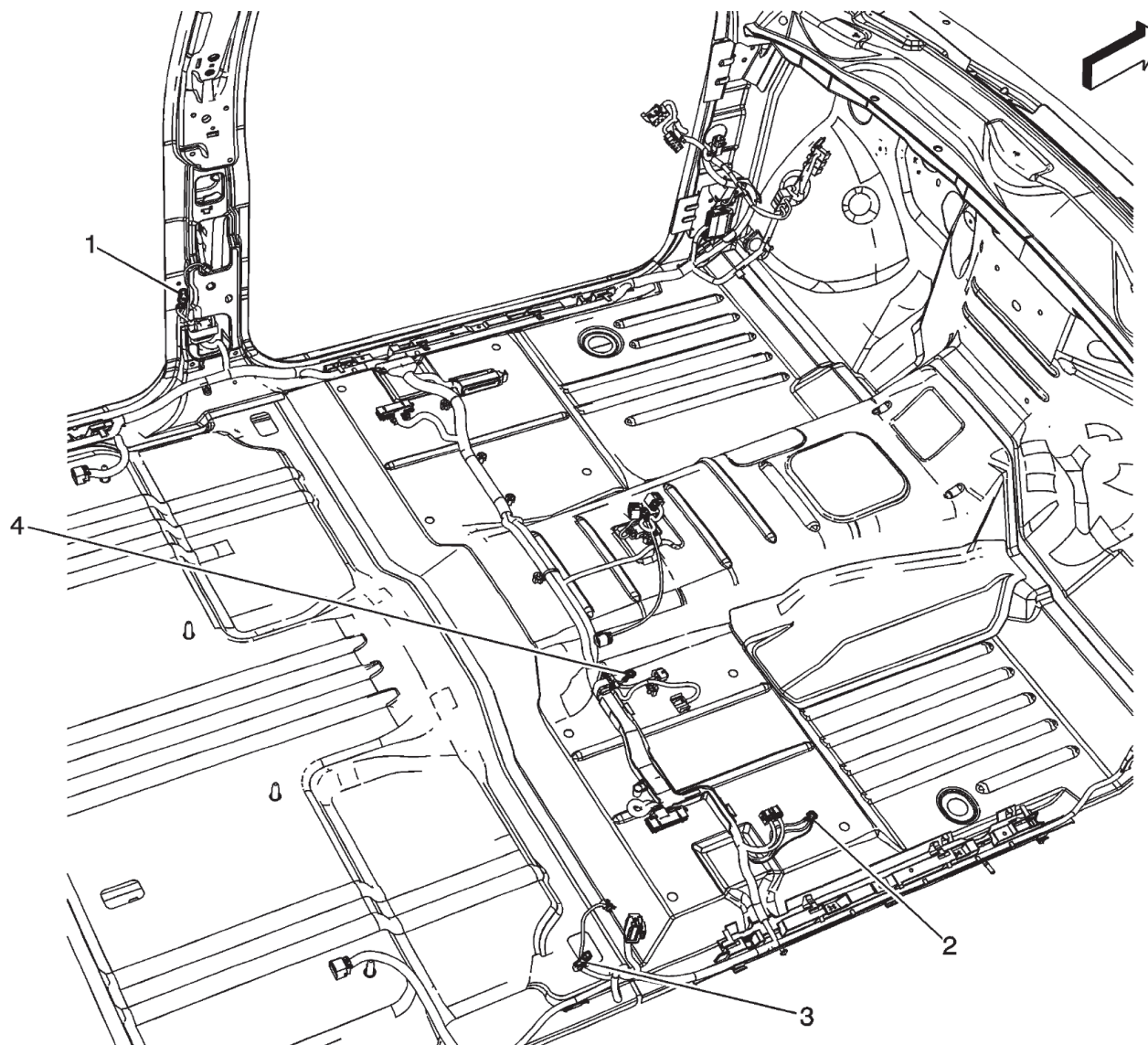

1822906

Ground Distribution: G305 Ground

G305

- (1) Fuel Tank
- (2) Frame
- (3) G305

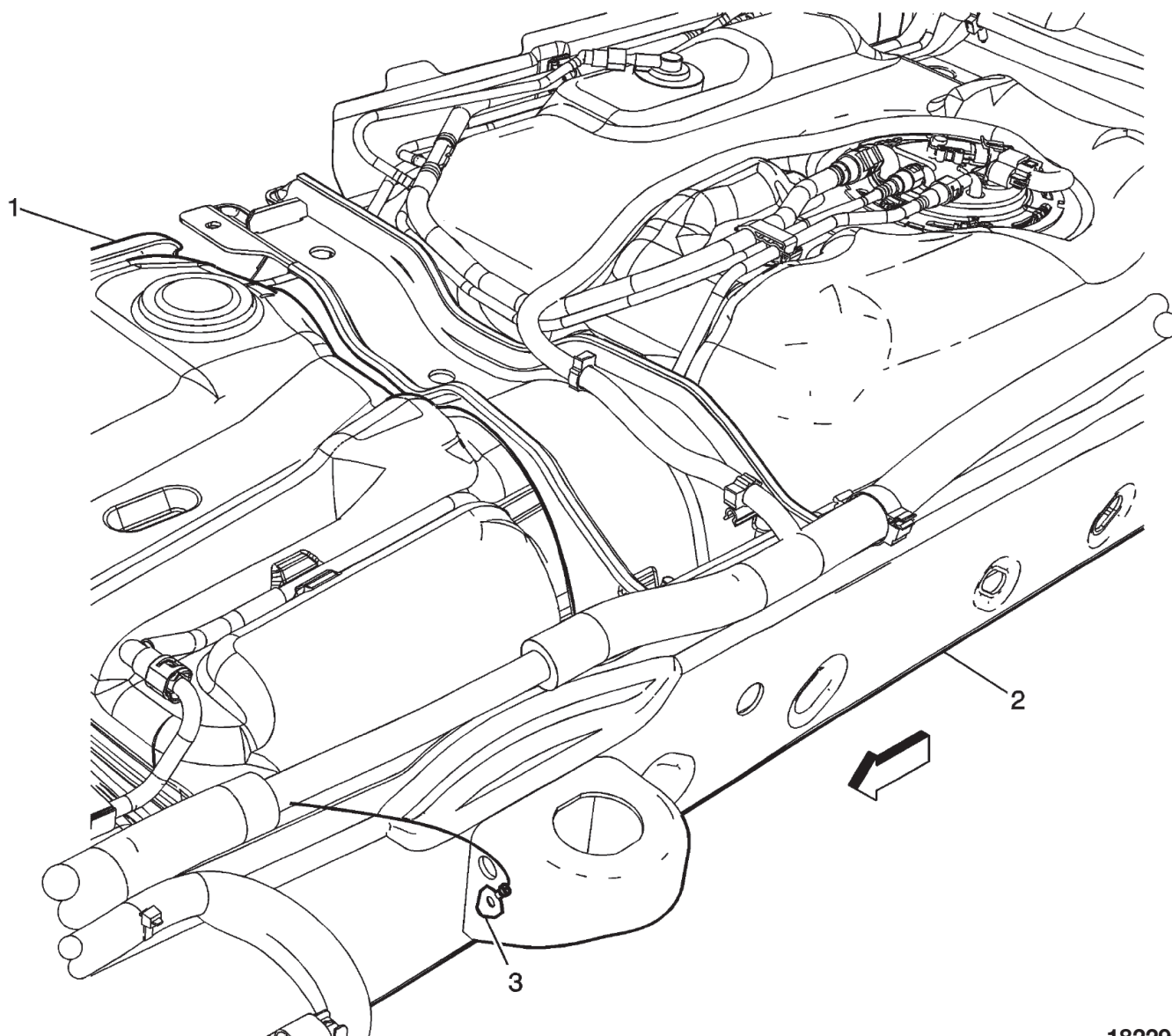

1822905

Electrical Component Locations

Component Name	Location
1-2 Shift Solenoid (1-2 SS) Valve (M30/M70)	In the automatic transmission
2-3 Shift Solenoid (2-3 SS) Valve (M30/M70)	In the automatic transmission
3-2 Shift Solenoid (3-2 SS) Valve (M30/M70)	In the automatic transmission
A/C Compressor Clutch (C67/CJ2 +4.3L)	Mounted to the front of the A/C compressor
A/C Compressor Clutch (C67/CJ2 -4.3L)	Mounted to the front of the A/C compressor
A/C Low Pressure Switch (Gas +C67/CJ2)	Right rear of the engine compartment on the right side of the A/C accumulator
A/C Low Pressure Switch (Diesel +C67/CJ2)	On the top right side of the A/C line
A/C Refrigerant Pressure Sensor (C67/CJ2 -Diesel)	In the right front of the engine compartment on the A/C high pressure hose near the compressor
A/C Refrigerant Pressure Sensor (C67/CJ2 +Diesel)	In the right front of the engine compartment on the A/C high pressure hose near the compressor
A/T Shift Lock Control Solenoid	Under the I/P mounted to the right side of the steering column
Accelerator Pedal Position (APP) Sensor	On the driver floor board above the accelerator pedal
Air Temperature Actuator - Left (CJ2)	Bottom center of the HVAC module assembly
Air Temperature Actuator - Right (CJ2)	Top middle of the HVAC module assembly
Air Temperature Actuator (C67/C42)	Top middle of the HVAC module assembly

(continued from column at left)

Component Name	Location
Air Temperature Sensor - Lower Left (CJ2)	Left side of the HVAC module near the mode actuator
Air Temperature Sensor - Lower Right (CJ2)	Lower left of the HVAC module to the left of the air temperature actuator - left
Air Temperature Sensor - Upper Left (CJ2)	At the top rear of the I/P below the dash trim panel to the left of the ambient light/sunload sensor
Air Temperature Sensor - Upper Right (CJ2)	At the top rear of the I/P below the dash trim panel to the right of the ambient light/sunload sensor
Ambient Air Temperature Sensor - HVAC (CJ2)	Front of the vehicle mounted to the front of the lower radiator core support, on the right
Ambient Air Temperature Sensor (DF5)	Attached to the left side of the radiator core support behind the grille
Ambient Light Sensor (C67/C42)	On the top center of the I/P mounted in the trim panel
Ambient Light/Sunload Sensor Assembly (CJ2)	On the top center of the I/P mounted in the trim panel
Audio Amplifier (UQA)	Mounted to floor under the rear of the center console
Audio/Video Adapter (U42)	Rear of the center console near the rear seat audio controller
Automatic Transmission (MYC/MYD)	Under the Vehicle, mounted to the rear of the engine
Automatic Transmission Fluid Pressure Manual Valve Position Switch (M30/M70)	In the automatic transmission
Automatic Transmission Input Shaft Speed (AT ISS) Sensor (MW7)	In the automatic transmission

(continued on Pg. B-43)

Electrical Component Locations (cont'd)

(continued from Pg. B-42)

Component Name	Location
Automatic Transmission Shift Lever (M30/M70/MYC/MYD/MW7)	Right side of the steering column to the rear of the steering wheel
Automatic Transmission Turbine Speed Sensor (MW7)	Mounted to the top left of the Transmission
Auxiliary Battery Relay (TP2)	At the left side rear of the engine compartment
Auxiliary Body Control Module (XBCM) (Export)	In the right side of the I/P, below the defrost deflector
Auxiliary Power Outlet - Bin (D07)	In the rear of the center console storage bin
Auxiliary Power Outlet - Center Seat (AZ3)	Between the Driver and Passenger Seats
Auxiliary Power Outlet - Console (D07)	Rear of the center console below the rear seat audio controller
Auxiliary Power Outlet - Front 1	Left center of the I/P to the left of the I/P multifunction switch assembly
Auxiliary Power Outlet - Front 2	Right center of the I/P to the right of the I/P multifunction switch assembly
Back-up Alarm (8S3)	On the rear of the vehicle frame
Backup Lamp - Left Rear	Left rear of the vehicle
Backup Lamp - Right Rear	Right rear of the vehicle
Battery Current Sensor (10 Series)	Part of the negative battery cable assembly
Battery - Left (Diesel 6A6/TP2)	Left front corner of engine compartment
Battery - Right	Right rear of the engine compartment to the rear of the coolant reservoir

(continued from column at left)

Component Name	Location
Blower Motor	Lower right side of the HVAC module below the passenger side of the I/P
Blower Motor Control Module	Lower right side of the HVAC module below the passenger side of the I/P to the left of the blower motor
Body Control Module (BCM)	On the lower left side of the I/P to the left of the steering column
Brake Booster Vacuum Sensor (JL4)	Left rear of the engine compartment near the fuse block - underhood
Brake Fluid Level Switch	Mounted to lower left side of the master cylinder
Brake Master Cylinder Pressure Sensor (JL1)	Left rear of the engine compartment near the fuse block
Camper/Trailer Blunt Cut (UY2)	On the left frame rail, near the front of the bed
Camshaft Actuator Solenoid (6.0L/6.2L)	Front of the engine, behind the water pump
Camshaft Position (CMP) Sensor	Front of the engine above the crank pulley
Cargo Lamp/Center High Mounted Stop Lamp (CHMSL)	Rear roof line above the rear window
Cellular Microphone (UE1/U3U/UVB)	In the overhead console
Central Sequential Fuel Injection (SFI) (4.3L)	Top of the engine between the throttle body and distributor
Chime Module (UL5)	Center of the I/P, behind the radio
Clearance Lamp - Left Front (R05)	Front of the left rear wheel flare
Clearance Lamp - Left Rear (R05)	Rear of the left rear wheel flare
Clearance Lamp - Right Front (R05)	Front of the right rear wheel flare

(continued on Pg. B-44)

Electrical Component Locations (cont'd)

(continued from Pg. B-43)

Component Name	Location
Clearance Lamp - Right Rear (R05)	Rear of the right rear wheel flare
Clearance Lamps (U01)	Center of the roof panel above the windshield
Cooling Fan - Left (Gas - LY6)	Left front of the engine compartment near the radiator
Cooling Fan - Right (Gas - LY6)	Right front of the engine compartment near the radiator
Courtesy/Reading Lamps - Front	Mounted in the overhead console
Courtesy/Reading Lamps - Rear (Extended Cab/Crew Cab)	In the headliner above the 2nd row seating
Crankshaft Position (CKP) Sensor (4.3L)	In the front lower right of the timing cover
Crankshaft Position (CKP) Sensor (Gas -4.3L)	On the right rear of the engine, behind the starter
Crankshaft Position (CKP) Sensor (Diesel)	Front of the engine to the lower left of the crank pulley
Data Link Connector (DLC)	Lower left side of instrument panel to the left of the steering column
Defogger Grid (C49)	Mounted to the rear glass
Digital Radio Receiver (U2K)	Right side of the I/P behind the I/P compartment
Door Latch Assembly - Driver	Inside the rear of the driver door below the outside door handle
Door Latch Assembly - Left Rear (Crew Cab)	Inside the rear of the left rear door near the outside door handle
Door Latch Assembly - Passenger	Inside the rear of the passenger door below the outside door handle
Door Latch Assembly - Right Rear (Crew Cab)	Inside the rear of the right rear door near the outside door handle

(continued from column at left)

Component Name	Location
Door Lock Switch - Driver (AU3 -AN3/DL3)	Mounted to the driver door trim panel
Door Lock Switch - Passenger (AU3 -AN3/DL3)	Mounted to the passenger door trim panel
DPF Differential Pressure Sensor (Diesel)	In the middle of the frame rail cross member, above the catalytic converter
Driver Door Switch (DDS) (AN3/DL3)	Mounted to the driver door trim panel
Driver Information Center (DIC) Switch (UK3)	Center of the I/P between the instrument cluster and the air vents
Driver Shift Request Switch (MYC/MYD/MW7)	Part of the automatic transmission shift lever
Electronic Adjustable Pedal Assembly (JF4)	Mounted under the lower left side of the instrument panel
Electronic Brake Control Module (EBCM)(JL4/JF3/JF7/JH6/JH7)	Mounted to the left side of the frame assembly below the driver seat
Emergency Vehicle Roof Lamp Relay (5Y0)	Behind the overhead console
Emergency Vehicle Wiring Blunt Cuts (5Y0)	Behind the overhead console
Engine Control Module (ECM)	Left front of the engine compartment near the fan shroud
Engine Coolant Level Switch (Diesel)	In the right front of the engine compartment, below the surge tank
Engine Coolant Temperature (ECT) Sensor (Gas +4.3L)	In the left front of the cylinder head, between the #3 and #5 cylinder exhaust ports
Engine Coolant Temperature (ECT) Sensor (4.8L/5.3L/6.0L/6.2L)	Near the left front cylinder head, at the cylinder #1 exhaust port

(continued on Pg. B-45)

Electrical Component Locations (cont'd)

(continued from Pg. B-44)

Component Name	Location
Engine Coolant Temperature (ECT) Sensor (Diesel)	Top front middle of the engine
Engine Oil Level Switch (4.8L/5.3L/6.0L/6.2L)	Mounted in the right side of the oil pan
Engine Oil Level Switch (Diesel)	Mounted on the left side of the oil pan
Engine Oil Pressure (EOP) Sensor (Gas)	Top rear of the engine to the rear of the intake manifold
Engine Oil Pressure (EOP) Sensor (Diesel)	On the left rear side of the engine block
Evaporative Emission (EVAP) Canister Purge Solenoid Valve (4.3L)	Attached to the intake manifold on the right side of the engine to the rear of the ignition coil
Evaporative Emission (EVAP) Canister Purge Solenoid Valve (4.8L/5.3L/6.0L/6.2L)	Top of the engine mounted to the intake manifold, on the left side of injector #1
Evaporative Emission (EVAP) Canister Vent Solenoid Valve (Gas)	Lower right rear of the vehicle, on the Evaporative Emission Canister
Exhaust Gas Recirculation (EGR) Valve (Diesel)	Top right front of the engine
Exhaust Gas Temperature (EGT) Sensor 1 (Diesel)	Under the left side of the vehicle, in front of the catalytic converter
Exhaust Gas Recirculation (EGR) Temperature Sensor 1 (Diesel)	--
Exhaust Gas Recirculation (EGR) Temperature Sensor 2 (Diesel)	--
Exhaust Gas Temperature (EGT) Sensor 2 (Diesel)	Under the left side of the vehicle, behind the catalytic converter
Exterior Illumination Lamp - Left (DL3/DR4/DPN)	Under the left outside rearview mirror

(continued from column at left)

Component Name	Location
Exterior Illumination Lamp - Right (DL3/DR4/DPN)	Under the right outside rearview mirror
Fog Lamp - Left Front (T96)	Lower left front of the vehicle
Fog Lamp - Right Front (T96)	Lower right front of the vehicle
Front Axle Actuator (NQF/NQG/NQH/NP2)	Mounted to the front axle assembly
Fuel Heater (Diesel)	Near the top of the fuel filter on the right side of the engine
Fuel Injector 1 (Diesel)	Near the right side engine rocker cover above cylinder #1
Fuel Injector 1 (Gas)	Upper left side of the engine, at cylinder #1
Fuel Injector 2 (Diesel)	Near the left side engine rocker cover above cylinder #2
Fuel Injector 2 (Gas)	Upper right side of the engine, at cylinder #2
Fuel Injector 3 (Diesel)	Near the right side engine rocker cover above cylinder #3
Fuel Injector 3 (Gas)	Upper left side of the engine, at cylinder #3
Fuel Injector 4 (Diesel)	Near the left side engine rocker cover above cylinder #4
Fuel Injector 4 (Gas)	Upper right side of the engine, at cylinder #4
Fuel Injector 5 (Diesel)	Near the right side engine rocker cover above cylinder #5
Fuel Injector 5 (Gas)	Upper left side of the engine, at cylinder #5
Fuel Injector 6 (Diesel)	Near the left side engine rocker cover above cylinder #6

(continued on Pg. B-46)

Electrical Component Locations (cont'd)

(continued from Pg. B-45)

Component Name	Location
Fuel Injector 6 (Gas)	Upper right side of the engine, at cylinder #6
Fuel Injector 7 (Diesel)	Near the right side engine rocker cover above cylinder #7
Fuel Injector 7 (Gas) (4.8L/5.3L/6.0L/6.2L)	Upper left side of the engine, at cylinder #7
Fuel Injector 8 (Diesel)	Near the left side engine rocker cover above cylinder #8
Fuel Injector 8 (Gas) (4.8L/5.3L/6.0L/6.2L)	Upper right side of the engine, at cylinder #8
Fuel Level Sensor - Primary (Diesel)	Inside the primary fuel tank, under the vehicle
Fuel Level Sensor - Secondary (Diesel - NQZ)	Inside the primary fuel tank, under the rear of the vehicle
Fuel Line Pressure Sensor (Gas - 4.3L/LMG/LY6/LC9)	In front of the Electronic Brake Control Module
Fuel Pressure Regulator (Diesel)	Mounted to the injection pump at the front of the engine center
Fuel Pump (Diesel)	On the left rear inner frame rail, in front of the rear fuel tank
Fuel Pump and Sender Assembly - Front (Gas)	Inside the fuel tank under the vehicle
Fuel Pump and Sender Assembly - Rear (Gas +LY6)	Inside the secondary fuel tank under the rear of the vehicle
Fuel Pump (FP) Relay - Secondary (Gas +LY6)	On the fuse block - underhood bracket
Fuel Rail Pressure (FRP) Sensor (Diesel)	Top of the engine mounted to the right fuel rail
Fuel Rail Temperature (FRT) Sensor (Diesel)	On the top left middle of the engine

(continued from column at left)

Component Name	Location
Fuel System Control Module (Gas - 4.3L/LMG/LY6/LC9)	Mounted to the rear frame, near the spare tire mount
Fuel Tank Pressure (FTP) Sensor (Gas)	Mounted to the fuel pump and sender assembly
Fuse Block - I/P	Left of the I/P behind the side trim panel
Fuse Block - Mobile Radio (9L4)	Right side of the I/P behind the I/P compartment
Fuse Block - Underhood	Left side of the engine compartment
Fuse Holder - Underhood	Right rear of engine compartment mounted to the bulk head
Garage Door Opener (UGI)	Front of the passenger compartment in the overhead console
Generator (4.3L)	Right front top of the engine
Generator (Gas -4.3L)	Upper left front corner of the engine
Generator - Left (Diesel +K76)	Upper left front corner of the engine
Generator - Right (Diesel)	Upper right front corner of the engine
Glow Plug 1 (Diesel)	Near the right side engine rocker cover above cylinder #1
Glow Plug 2 (Diesel)	Near the left side engine rocker cover above cylinder #2
Glow Plug 3 (Diesel)	Near the right side engine rocker cover above cylinder #3
Glow Plug 4 (Diesel)	Near the left side engine rocker cover above cylinder #4
Glow Plug 5 (Diesel)	Near the right side engine rocker cover above cylinder #5
Glow Plug 6 (Diesel)	Near the left side engine rocker cover above cylinder #6

(continued on Pg. B-47)

Electrical Component Locations (cont'd)

(continued from Pg. B-46)

Component Name	Location
Glow Plug 7 (Diesel)	Near the right side engine rocker cover above cylinder #7
Glow Plug 8 (Diesel)	Near the left side engine rocker cover above cylinder #8
Glow Plug Control Module (GPCM) (Diesel)	Left rear of the engine above the rocker cover to the left of the turbocharger
Headlamp - High Beam - Left	Left front of the vehicle
Headlamp - High Beam - Right	Right front of the vehicle
Headlamp - Low Beam - Left	Left front of the vehicle
Headlamp - Low Beam - Right	Right front of the vehicle
Headlamp and Panel Dimmer Switch	Left side of the I/P to the left side of the steering column
Heated Exygen Sensor (H02S) Bank 1 Sensor 1 (Gas)	Under the vehicle to the left side of the engine, in front of the catalytic converter
Heated Exygen Sensor (H02S) Bank 1 Sensor 2 (Gas)	Under the vehicle to the left side of the engine, behind the catalytic converter
Heated Exygen Sensor (H02S) Bank 2 Sensor 1 (Gas)	Under the vehicle to the right side of the engine, in front of the catalytic converter
Heated Exygen Sensor (H02S) Bank 2 Sensor 2 (Gas)	Under the vehicle to the right side of the engine, behind the catalytic converter
Heated Seat Element - Driver Back (AN3)	Under the driver seat back upholstery
Heated Seat Element - Driver Cushion (AN3)	Under the driver seat cushion upholstery
Heated Seat Element - Passenger Back (AN3)	Under the passenger seat back upholstery

(continued from column at left)

Component Name	Location
Heated Seat Element - Passenger Cushion (AN3)	Under the passenger seat cushion upholstery
Heated Seat Switch - Passenger (AN3)	Passenger door panel above the passenger door switch assembly
Heated Steering Wheel (KA9)	On the steering wheel
Heated Steering Wheel Control Module (KA9)	Lower left side of the steering wheel assembly behind the inflatable restraint steering wheel module
Hood Ajar Switch (AP3/AP8)	Part of the hood latch assembly
Horn - Left	Lower left front of the vehicle
Horn - Right (7Z1/YE9)	Lower right front of the vehicle
Horn Switch	In the steering wheel behind the inflatable restraint steering wheel module
HVAC Control Module	Center of the I/P below the radio
I/P Multifunction Switch Assembly (JL4/JF4/UD7/XA7)	Center of the I/P below the HVAC controls
Ignition Coil 1 (4.8L/5.3L/6.0L/6.3L)	Upper left side of the engine, at cylinder #1
Ignition Coil 2 (4.8L/5.3L/6.0L/6.3L)	Upper right side of the engine, at cylinder #2
Ignition Coil 3 (4.8L/5.3L/6.0L/6.3L)	Upper left side of the engine, at cylinder #3
Ignition Coil 4 (4.8L/5.3L/6.0L/6.3L)	Upper right side of the engine, at cylinder #4
Ignition Coil 5 (4.8L/5.3L/6.0L/6.3L)	Upper left side of the engine, at cylinder #5
Ignition Coil 6 (4.8L/5.3L/6.0L/6.3L)	Upper right side of the engine, at cylinder #6

(continued on Pg. B-48)

Electrical Component Locations (cont'd)

(continued from Pg. B-47)

Component Name	Location
Ignition Coil 7 (4.8L/5.3L/6.0L/6.3L)	Upper left side of the engine, at cylinder #7
Ignition Coil 8 (4.8L/5.3L/6.0L/6.3L)	Upper right side of the engine, at cylinder #8
Ignition Control Module (ICM) (4.3L)	Mounted to the right front of the intake manifold in front of the ignition coil
Ignition Switch	In the upper steering column on the ignition key cylinder housing
Inclination Sensor (SPO Alarm)	Behind the left I/P knee bolster on the floor heater duct
Inflatable Restraint Front Sensor - Left (10 Series)	Left front of the engine compartment on the lower radiator core support
Inflatable Restraint Front Sensor - Right (10 Series)	Right front of the engine compartment on the lower radiator core support
Inflatable Restraint Front Sensor (-10 Series)	Under the center of the radiator core support
Inflatable Restraint I/P Module	Right side of the I/P directly in front of the passenger seat
Inflatable Restraint I/P Module Disable Switch	In the I/P to the right of the radio
Inflatable Restraint Passenger Air Bag ON/OFF Indicator (AL0/C99)	Front of the passenger compartment in the overhead console
Inflatable Restraint Passenger Pres- ence System (PPS) Module (AL0)	Under the front passenger seat
Inflatable Restraint Passenger Seat Belt Tension Sensor (AL0)	Part of the passenger seat belt buckle
Inflatable Restraint Roof Rail Module - Left (ASF)	Behind the left side of the headliner trim to the rear of the C-pillar
Inflatable Restraint Roof Rail Module - Right (ASF)	Behind the right side of the head- liner trim to the rear of the C-pillar

(continued from column at left)

Component Name	Location
Inflatable Restraint Seat Position Sensor (SPS) - Left (10 Series)	Right front corner of the driver seat track assembly
Inflatable Restraint Sensing and Diagnostic Module (SDM)	Under the driver seat
Inflatable Restraint Side Impact Sensor (SIS) - Left Front (ASF)	Inside the driver door
Inflatable Restraint Side Impact Sensor (SIS) - Left Rear (ASF + Crew Cab/Extended Cab)	Inside the left rear door
Inflatable Restraint Side Impact Sensor (SIS) - Right Front (ASF)	Inside the passenger door
Inflatable Restraint Side Impact Sensor (SIS) - Right Rear (ASF + Crew Cab/Extended Cab)	Inside the right rear door
Inflatable Restraint Steering Wheel Module	On the steering wheel
Inflatable Restraint Steering Wheel Module Coil	In the steering column behind the steering wheel
Inflatable Restraint Vehicle Rollover Sensor (ASF)	Below the center console
Information Center Telltale Assembly (UD7)	Top rear of the passenger compart- ment above the rear window
Infrared Module (U42)	In the roof mounted DVD system
Input Speed Sensor (ISS) (M30/M70/MYC/MYD)	In the automatic transmission
Inside Air Temperature Sensor - Front (CJ2)	Left side of the headliner between A-pillar and B-pillar
Inside Rearview Mirror (ISRVM)	Mounted at the top center of the windshield

(continued on Pg. B-49)

Electrical Component Locations (cont'd)

(continued from Pg. B-48)

Component Name	Location
Instrument Panel Cluster	Left side of the I/P above the steering column
Intake Air Heater (1AH) Module (Diesel)	Mounted at the front of the engine center
Intake Air Temperature (IAT) Sensor 2 (Diesel)	On the top front middle of the engine
Intake Air Valve (Diesel)	On the top right front of the engine
Internal Mode Switch (MYC/MYD)	In the automatic transmission
Junction Block - Left I/P	Lower left side of instrument panel to the left of the steering column
Junction Block - Rear Lamps	Inside of the left frame rail near the rear of the vehicle
Junction Block - Right I/P	Right side of the I/P behind the end trim panel
Knock Sensor (KS) - 1 (Gas)	Lower left side of engine
Knock Sensor (KS) - 2 (Gas)	Lower right side of engine
License Lamp - Left	Left center of the rear bumper
License Lamp - Right	Right center of the rear bumper
Line Pressure Control (PC) Solenoid (MYC/MYD)	Part of the automatic transmission
Manifold Absolute Pressure (MAP) Sensor	Top of the engine above intake manifold
Marker Lamp - Left Front (Z88)	Left front of the vehicle
Marker Lamp - Left Rear (Z88)	Part of the left rear tail lamp assembly
Marker Lamp - Right Front (Z88)	Right front of the vehicle
Marker Lamp - Right Rear (Z88)	Part of the right rear tail lamp assembly
Marker Lamp - Tailgate (R05)	Below the tailgate directly above the license plate

(continued from column at left)

Component Name	Location
Mass Air Flow (MAF)/Intake Air Temperature (IAT) Sensor (Gas)	Right front of the engine compartment, in the air cleaner duct
Mass Air Flow (MAF)/Intake Air Temperature (IAT) Sensor (Diesel)	Right front of the engine compartment, in the air cleaner duct
Memory Seat Module (AN3)	Under the front of the driver seat above the seat track
Memory/Heated Seat Switch (AN3)	Driver door panel above the driver door switch assembly
Mod Main Pressure Control Solenoid (MW7)	In the automatic transmission
Mode Actuator	Left side of the HVAC module assembly
Mobile Radio Blunt Cut (9L4)	Below the center of the I/P
Noise Compensation Microphone (Y91)	Inside the center console
Object Sensor - Left Rear Corner (UD7)	Left rear corner of the bumper cover
Object Sensor - Left Rear Middle (UD7)	Left side of the bumper cover
Object Sensor - Right Rear Corner (UD7)	Right rear corner of the bumper cover
Object Sensor - Right Rear Middle (UD7)	Right side of the bumper cover
Output Speed Sensor (OSS) (MYC/MYD)	In the automatic transmission
Outside Moisture Sensor (CE1)	Mounted to the windshield near the inside rearview mirror
Outside Rearview Mirror - Driver (-DL3)	On the left front door
Outside Rearview Mirror - Driver (+DL3)	On the left front door

(continued on Pg. B-50)

Electrical Component Locations (cont'd)

(continued from Pg. B-49)

Component Name	Location
Outside Rearview Mirror - Passenger (-DL3)	On the right front door
Outside Rearview Mirror - Passenger (+DL3)	On the right front door
Outside Rearview Mirror Switch (-DL3)	In the left front door trim panel
Park Brake Switch	Under the driver side I/P mounted to the park brake pedal assembly
Park/Neutral Position (PNP) Switch (M30/M70)	Mounted to the left front of the transmission, at the shift shaft
Park/Turn Signal Lamp - Left Front Lower	Left front of the vehicle
Park/Turn Signal Lamp - Left Front Upper	Left front of the vehicle
Park/Turn Signal Lamp - Right Front Lower	Right front of the vehicle
Park/Turn Signal Lamp - Right Front Upper	Right front of the vehicle
Passenger Door Switch (PDS) (AN3/DL3)	Mounted to the passenger door trim panel
Power Brake Booster (JL4)	Left rear corner of the engine compartment near the master cylinder
Power Take Off Blunt Cut (PTO)	--
Power Take off (PTO) Module (PTO)	On the right side outer frame rail, near the right front tire
Power Take off (PTO) Relay (PTO)	In the engine compartment
Power Take off (PTO) Switch (PTO)	Center of the I/P to the right of the radio
Pressure Control (PC) Solenoid Valve (M30/M70)	In the automatic transmission

(continued from column at left)

Component Name	Location
Pressure Control Solenoid 1 (PCS1) (MW7)	In the automatic transmission
Pressure Control Solenoid 2 (PCS2) (MW7)	In the automatic transmission
Pressure Control (PC) Solenoid 2 (MYC/MYD)	Part of the automatic transmission
Pressure Control (PC) Solenoid 3 (MYC/MYD)	Part of the automatic transmission
Pressure Control (PC) Solenoid 4 (MYC/MYD)	Part of the automatic transmission
Pressure Control (PC) Solenoid 5 (MYC/MYD)	Part of the automatic transmission
Pressure Switch Manifold (PSM) (MW7)	In the automatic transmission
Radio	Center of the I/P
Rear Object Control Module (UD7)	Under the right front seat
Rear Seat Audio (RSA) Controller (UK6)	Rear of the center console
Recirculation Actuator (CJ2/C67)	Top of the HVAC module on the right side
Remote Control Door Lock Receiver (RCDLR) (AP3/AP8)	Top rear of the passenger compartment above the rear window
Roof Beacon Switch (5X7/5Y0/TRW)	In the overhead console
Roof Beacon Relay (TRW)	Behind the overhead console, near the top
Roof Marker Lamp - Left (U01)	On the left side of the roof, above the windshield
Roof Marker Lamp - Right (U01)	On the right side of the roof, above the windshield

(continued on Pg. B-51)

Electrical Component Locations (cont'd)

(continued from Pg. B-50)

Component Name	Location
Roof Mounted Beacon Blunt Cuts (TRW)	Behind the overhead console, on the right
Rotational Position Sensor (NQH)	Mounted to the transfer case
Run Relay (TP2)	At the right rear of the engine compartment, near the underhood fuse holder
Seat Adjuster Assembly - Driver (AG1)	Below the driver seat mounted to the seat track
Seat Adjuster Assembly - Passenger (AG2)	Below the passenger seat mounted to the seat track
Seat Adjuster Switch - Driver (AG1)	Lower left side of the driver seat
Seat Adjuster Switch - Passenger (AG2)	Lower right side of the passenger seat
Seat Belt Buckle - Driver	Right rear corner of the driver seat cushion frame
Seat Belt Buckle - Passenger (10 Series)	Left rear corner of the passenger seat cushion frame
Seat Belt Pretensioner - Driver	Part of the driver seat belt retractor assembly
Seat Belt Pretensioner - Passenger	Part of the passenger seat belt retractor assembly
Seat Front Vertical Motor - Driver (AG1)	Part of the seat adjuster assembly - driver
Seat Front Vertical Motor - Passenger (AG2)	Part of the seat adjuster assembly - passenger
Seat Front Vertical Motor Position Sensor (AN3)	Under the driver seat, toward the middle
Seat Horizontal Motor - Driver (AG1)	Part of the seat adjuster assembly - driver

(continued from column at left)

Component Name	Location
Seat Horizontal Motor - Passenger (AG2)	Part of the seat adjuster assembly - passenger
Seat Horizontal Motor Position Sensor - Driver (AN3)	Under the driver seat, toward the front
Seat Lumbar Horizontal Motor - Driver (AN3)	In the driver seat back, on the left
Seat Lumbar Horizontal Motor - Passenger (AN3)	In the passenger seat back, on the right
Seat Lumbar Horizontal Motor Position Sensor- Driver (AN3)	In the driver seat back, on the left
Seat Lumbar Switch - Driver (AN3)	Lower left side of the driver seat
Seat Lumbar Switch - Passenger (AN3)	Lower right side of the passenger seat
Seat Lumbar Vertical Motor - Driver (AN3)	In the driver seat back, on the right
Seat Lumbar Vertical Motor - Passenger (AN3)	In the passenger seat back, on the left
Seat Lumbar Vertical Motor Position Sensor- Driver (AN3)	In the driver seat back, on the right
Seat Rear Vertical Motor - Driver (AG1)	Part of the seat adjuster assembly - driver
Seat Rear Vertical Motor - Driver (AG2)	Part of the seat adjuster assembly - passenger
Seat Recline Motor - Driver (AN3)	Lower right side of the driver seat back, below the seat back upholstery
Seat Recline Motor - Passenger (AN3)	Lower right side of the passenger seat back, below the seat back upholstery
Seat Recline Position Sensor - Driver (AN3)	Lower right side of the driver seat back, below the seat back upholstery

(continued on Pg. B-52)

Electrical Component Locations (cont'd)

(continued from Pg. B-51)

Component Name	Location
Security Indicator Lamp (SPO Alarm)	--
Shift Solenoid 1 (SS1) (MW7)	In the automatic transmission
Shift Solenoid 2 (SS2) (MW7)	In the automatic transmission
Shift Solenoid 3 (SS3) (MW7)	In the automatic transmission
Shift Solenoid (SS) 1 (MYC/MYD)	Part of the automatic transmission
Shift Solenoid (SS) 2 (MYC/MYD)	Part of the automatic transmission
Shock Sensor (SPO Alarm)	Under the left side of the I/P
Sliding Rear Window Close Relay (A48)	On the right rear of the cab wall, behind the trim panel
Sliding Rear Window Motor (A48)	Below the rear window
Sliding Rear Window Open Relay (A48)	On the right rear of the cab wall, behind the trim panel
Sliding Rear Window Switch (A48)	In the overhead console
Speaker - Center (UQA +Y91)	In the center of the upper I/P pad
Speaker - Left Front	Behind the left front door trim panel
Speaker - Left Front Tweeter (UQ3/UQA)	Behind the left A-pillar trim panel
Speaker - Left Rear (Regular Cab)	Behind the left B-pillar trim panel
Speaker - Left Rear Door (Extended Cab/Crew Cab)	Behind the left rear door trim panel
Speaker - Right Front	Behind the passenger door trim panel
Speaker - Right Front Tweeter (UQ3/UQA)	Behind the right A-pillar trim panel
Speaker - Right Rear (Regular Cab)	Behind the right B-pillar trim panel
Speaker - Right Rear Door (Extended Cab/Crew Cab)	Behind the right rear door trim panel
Starter	Lower right corner of the engine

(continued from column at left)

Component Name	Location
Steering Angle Sensor (JL4)	Mounted to the steering column below the shift interlock solenoid
Steering Wheel Control Switch Assembly - Left (K34/KA9)	Left center of the steering wheel to the left of the inflatable restraint steering wheel module
Steering Wheel Control Switch Assembly - Right (UK3)	Right center of the steering wheel to the right of the inflatable restraint steering wheel module
Stop Lamp Switch	Top of the brake pedal assembly
Sunroof Module (CF5)	Front of the passenger compartment above the headliner
Sunroof Switch (CF5)	Front of the passenger compartment in the overhead console
Sunshade - Left (DH6)	Front left roof line mounted to the headliner
Sunshade - Right (DH6)	Front right roof line mounted to the headliner
Tail/Stop and Turn Signal Lamp - Lower Left	Left rear of the vehicle
Tail/Stop and Turn Signal Lamp - Lower Right	Right rear of the vehicle
Tail/Stop and Turn Signal Lamp - Upper Left	Left rear of the vehicle
Tail/Stop and Turn Signal Lamp - Upper Right	Right rear of the vehicle
Terminator Resistor	In the chassis harness on the left rear chassis crossmember near the evaporative emissions canister
Theft Deterrent Control Module	Right side of the steering column near the ignition key cylinder

(continued on Pg. B-53)

Electrical Component Locations (cont'd)

(continued from Pg. B-52)

Component Name	Location
Throttle Body (Gas)	Mounted to the front of the intake manifold
Torque Converter Clutch (TCC) Solenoid Valve (M30/M70)	In the automatic transmission
Torque Converter Clutch Pressure Control Solenoid (TCC PCS) (MW7)	In the automatic transmission
Torque Converter Clutch Pulse Width Modulation (TCC PWM) Solenoid Valve (M30/M70)	In the automatic transmission
Torque Converter Clutch (TCC) Pressure Control (PC) Solenoid (MYC/MYD)	Part of the automatic transmission
Tow/Haul Switch (M30/M70/MYC/MYD/MW7)	Part of the automatic transmission shift lever
Traction Control Switch (JL4)	Center of the I/P near the radio, part of the I/P multifunction switch assembly
Trailer Blunt Cut (Export)	--
Trailer Brake Blunt Cut (Domestic)	Under the left side of the I/P, taped to the BCM wiring
Trailer Brake Control Panel Switch (JL1)	Lower left side of the I/P
Trailer Brake Controller Module (TBCM) (JL1 +20/30 Series)	On the left side inner frame rail, near the rear of the vehicle
Trailer Brake Controller Module (TBCM) (JL1 +31 Series)	On the right side inner frame rail, near the rear of the vehicle
Trailer Brake Controller Solid State Relay (JL1 +20/30 Series)	On the left side inner frame rail, near the rear of the vehicle
Trailer Brake Controller Solid State Relay (JL1 +31 Series)	On the right side inner frame rail, near the rear of the vehicle

(continued from column at left)

Component Name	Location
Trailer Connector (UY7)	Rear of the vehicle, to the left of the license plate
Transfer Case Encoder Motor (NQF/NQH)	Mounted to the transfer case
Transfer Case Shift Control Module (NQF/NQH)	Lower left side of the I/P near the steering column
Transfer Case Shift Control Switch (NQF/NQH -YE9)	Center of the I/P, to the left of the radio
Transfer Case Shift Control Switch (NQF/NQH +YE9)	Left side of the I/P, to the left of the steering wheel
Transfer Case Shift Control Switch (NQG/NP2)	On top of the transfer case
Transmission Control Module (TCM) (M30/M70/MW7)	Left front of the engine compartment near the fan shroud
Transmission Control Module (TCM) (MYC/MYD)	Part of the automatic transmission
Transmission Fluid Pressure (TFP) Switch (MYC/MYD)	Part of the automatic transmission
Transmission Fluid Temperature (TFT) Sensor (MYC/MYD)	Part of the automatic transmission
Transmission Internal Mode Switch (MW7)	In the automatic transmission
Turbocharger Vane Position Control Solenoid Valve (Diesel)	On the top center of the engine
Turbocharger Vane Position Sensor (Diesel)	On the top left front of the engine
Turn Signal Malfunction Switch	Mounted to the left side of the steering column behind the steering wheel

(continued on Pg. B-54)

Electrical Component Locations (cont'd)

(continued from Pg. B-53)

Component Name	Location
Valve Lifter Oil Manifold (VLOM) Assembly (5.3L/6.0L/6.2L)	Mounted in the valve lifter valley below the intake manifold
Vehicle Communication Interface Module (VCIM) (UE1 +YE9)	Center of the I/P, behind the HVAC control head
Vehicle Communication Interface Module (VCIM) (UE1 -YE9)	Center of the I/P, below the lower center I/P Panel
Vehicle Speed Sensor (VSS) (M30/M70/MYD/MW7)	In the tailshaft housing of the transmission
Video Display (U42)	In the headliner between the front and second row seating
Washer Fluid Level Switch	Mounted in bottom of the washer fluid reservoir
Water In Fuel Sensor (Diesel)	Bottom of the fuel filter on the right side of the engine
Wheel Speed Sensor (WSS) - Left Front (JL4/JF3/JF7/JH6/JH7)	Mounted to the left front steering knuckle assembly
Wheel Speed Sensor (WSS) - Left Rear (JL4)	Mounted to the left rear brake backing plate
Wheel Speed Sensor (WSS) - Right Front (JL4/JF3/JF7/JH6/JH7)	Mounted to the right front steering knuckle assembly
Wheel Speed Sensor (WSS) - Right Rear (JL4)	Mounted to the left rear brake backing plate
Window Motor - Driver (A31)	Inside the driver door mounted to the window regulator, to the rear of the door speaker
Window Motor - Left Rear (Crew Cab +31/Extended Cab +ABV)	Inside the left rear door mounted to the window regulator, above the door speaker
Window Motor - Passenger (A31)	Inside the passenger door mounted to the window regulator, to the rear of the door speaker

(continued from column at left)

Component Name	Location
Window Motor - Right Rear (Crew Cab +31/Extended Cab +ABV)	In the right rear door mounted to the window regulator
Window Switch - Driver (A31 -AN3/DL3)	In the left front door trim panel
Window Switch - Left Rear (Crew Cab +31/Extended Cab +ABV)	In the left rear door trim panel
Window Switch - Passenger (A31 -AN3/DL3)	In the right front door trim panel
Window Switch - Right Rear (Crew Cab +31/Extended Cab +ABV)	In the right rear door trim panel
Windshield Washer Fluid Pump	Left front corner of the engine compartment mounted in the bottom of the windshield washer fluid reservoir
Windshield Washer Solvent Heater (XA7)	Left rear corner of the engine compartment
Windshield Wiper Motor	Under the windshield cowl between the wiper arms
Wrecker Relay (5X7)	In the right rear corner of the engine compartment, above the right front wheel house
Yaw Rate and Lateral Acceleration Sensor (JL4)	Under the center console trim panel

Engine Control Module (ECM): LU3 - 4.3L Gas - Connector X-1

OEM: 15499466
 Service: 88988931
 Description: 73-Way F Receptacle 0.64 2.8 Sealed (BK)

Pin	Wire Color	Circuit No.	Function
1	0.35 D-BU	1161	APP Sensor 1 Signal
2	0.5 PU	1670	HO2S High Signal Bank 2 Sensor 2
3	0.5 D-BU	5985	Accessory Wakeup Serial Data
4	--	--	Not Used
5	0.35 D-GN	335	Low Speed Cooling Fan Relay Control
6	0.35 D-GN/WH	465	Fuel Pump Relay Control-Primary
7	--	--	Not Used
8	0.35 TN	5514	Low Reference (CJ2/C67)
9	0.5 TN/WH	1669	HO2S Low Signal Bank 1 Sensor 2
10	0.5 TN	1671	HO2S Low Signal Bank 2 Sensor 2
11-12	--	--	Not Used
13	0.35 YE	5991	Powertrain Relay Coil Control
14	--	--	Not Used
15	0.5 GY/WH	3122	HO2S Heater Low Control Bank 1 Sensor 2
16	0.5 OG/WH	3223	HO2S Heater Low Control Bank 2 Sensor 2
17	0.5 PU/WH	1668	HO2S High Signal Bank 1 Sensor 2
18	0.35 L-BU	1162	APP Sensor 2 Signal
19	0.5 PK	439	Ignition 1 Voltage
20	0.5 RD/WH	440	Battery Positive Voltage
21	0.35 PU	1272	Low Reference
22-23	--	--	Not Used

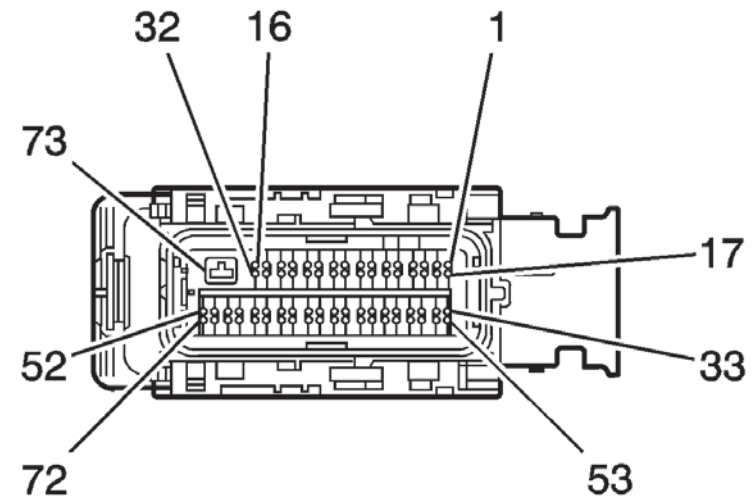
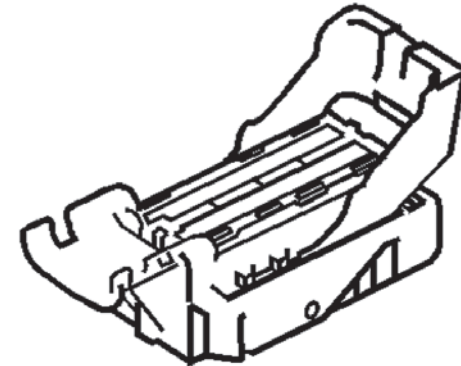

(chart continued on next page)

Engine Control Module (ECM): LU3 - 4.3L Gas - Connector X-1 (continued)

chart continued from previous page

Pin	Wire Color	Circuit No.	Function
24	0.35 TN/BK	6049	Low Reference
25	0.35 OG/BK	380	A/C Refrigerant Pressure Sensor Signal (CJ2/C67)
26	0.5 GY/BK	1694	4WD Low Signal (NQG/NP2)
27	0.35 BN/WH	419	MIL Control
28-29	--	--	Not Used
30	0.35 D-GN/WH	459	A/C Compressor Clutch Relay Control (CJ2/C67)
31	--	--	Not Used
32	0.35 YE/BK	625	Starter Relay Coil Control
33-34	--	--	Not Used
35	0.5 TN	2760	Low Reference
36	--	--	Not Used
37	0.5 YE	492	MAF Sensor Signal
38	--	--	Not Used
39	0.35 PU	1589	Fuel Level Sensor Signal - Primary
40	--	--	Not Used
41	0.35 BN	1271	Low Reference
42	0.35 D-GN	890	Fuel Tank Pressure Sensor Signal
43	0.5 TN/BK	2500	High Speed GMLAN Serial Data Bus+
44	0.5 TN	2501	High Speed GMLAN Serial Data Bus-

Pin	Wire Color	Circuit No.	Function
45-46	--	--	Not Used
47	0.35 WH/BK	1164	5V-2
48	--	--	Not Used
49	0.35 D-BU	473	High Speed Cooling Fan Relay Control
50	0.35 YE/BK	1827	Vehicle Speed Signal
51-53	--	--	Not Used
54	0.35 OG/BK	6399	Replicated TOS Signal
55	0.5 L-BU/WH	6311	TCC Brake Signal
56	--	--	Not Used
57	0.35 OG/BK	1786	Park/Neutral Signal
58	0.5 TN	472	IAT Sensor Signal
59-64	--	--	Not Used
65	0.35 GY	2700	5V-1
66	0.35 GY	2709	5V-1
67	0.35 TN	1274	5V-1
68-69	--	--	Not Used
70	0.5 WH	1310	EVAP Canister Vent Solenoid Control
71	--	--	Not Used
72	0.5 TN/WH	1695	Axle Switch Signal (NQG/NP2)
73	0.5 PK	1339	Ignition 1 Voltage

Engine Control Module (ECM): LU3 - 4.3L Gas - Connector X-2

OEM: 15497996
 Service: 88988372
 Description: 73-Way F 0.64 2.8 Series Sealed (BK)

Pin	Wire Color	Circuit No.	Function
1-3	--	--	Not Used
4	0.5 TN	2761	Low Reference
5	0.35 GY/BK	6272	Low Reference
6	0.5 TN	1744	Fuel Injector 1 Control
7	0.5 YE/BK	846	Fuel Injector 6 Control
8	0.5 TN/WH	845	Fuel Injector 5 Control
9	0.5 BN	2129	Low Reference
10	0.5 L-BU/BK	844	Fuel Injector 4 Control
11	0.5 PK/BK	1746	Fuel Injector 3 Control
12	0.5 L-GN/BK	1745	Fuel Injector 2 Control
13	0.5 GY	2704	5V-1
14-15	--	--	Not Used
16	0.5 YE	581	TAC Motor Control - 1
17-19	--	--	Not Used
20	0.35 BN	6266	Low Reference
21	--	--	Not Used
22	0.5 PU	2121	IC 1 Control
23	0.5 L-BU	2123	IC 3 Control
24	0.5 OG/WH	2122	IC 2 Control
25-29	--	--	Not Used
30	0.5 D-GN/WH	428	EVAP Canister Purge Solenoid Control

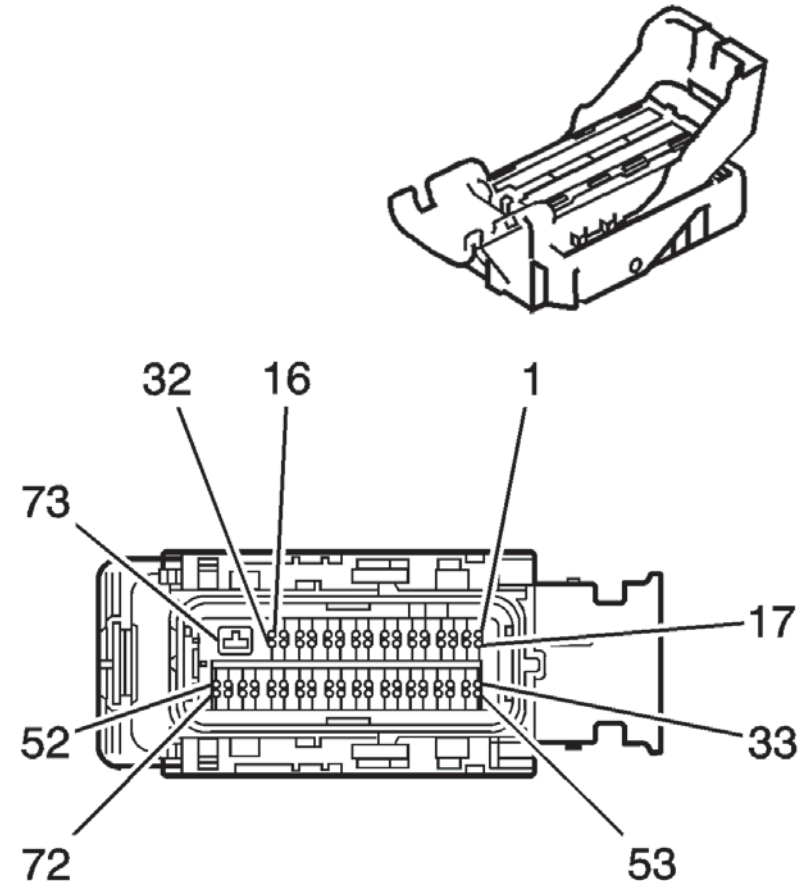

(chart continued on next page)

Engine Control Module (ECM): LU3 - 4.3L Gas - Connector X-2 (continued)

chart continued from previous page

Pin	Wire Color	Circuit No.	Function
31	0.5 BN	25	Charge Indicator Signal
32	0.5 BN	582	TAC Motor Control - 2
33	0.35 D-BU	6259	5V-1
34	--	--	Not Used
35	0.35 GY	2705	5V-1
36	0.35 TN/WH	331	Oil Pressure Sensor Signal
37	0.5 PU/WH	1665	HO2S High Signal Bank 1 Sensor 1
38	0.5 PU	1666	HO2S High Signal Bank 2 Sensor 1
39	0.5 L-GN	432	MAP Sensor Signal
40	0.35 TN	2752	Low Reference
41	0.35 BK	2755	Low Reference
42	--	--	Not Used
43	0.5 GY	23	Generator Field Duty Cycle Signal
44	--	--	Not Used
45	0.35 WH/BK	6271	CKP Sensor Signal
46	0.35 D-BU/WH	6265	CMP Sensor Signal
47	--	--	Not Used
48	0.5 TN	1664	HO2S Low Signal Bank 1 Sensor 1
49	0.5 OG/BK	469	Low Reference

Pin	Wire Color	Circuit No.	Function
50	0.5 GY	1716	KS 1 Signal
51	0.5 D-BU	496	KS 1 Signal
52	--	--	Not Used
53	0.35 GY	2701	5V-2
54	0.35 PU/WH	6270	5V-2
55-56	--	--	Not Used
57	0.35 D-GN	485	TP Sensor 1 Signal
58	0.5 YE	410	ECT Sensor Signal
59	0.35 PU	486	TP Sensor 2 Signal
60-64	--	--	Not Used
65	0.5 GY/WH	3113	HO2S Heater Low Control Bank 1 Sensor 1
66	0.5 L-GN	3212	HO2S Heater Low Control Bank 2 Sensor 1
67	--	--	Not Used
68	0.5 TN	1667	HO2S Low Signal Bank 2 Sensor 1
69	--	--	Not Used
70	0.5 GY	2303	KS 2 Signal
71	0.5 L-BU	1876	KS 2 Signal
72	--	--	Not Used
73	3 BK/WH	451	Ground

Engine Control Module (ECM): LU3 - 4.3L Gas - Location

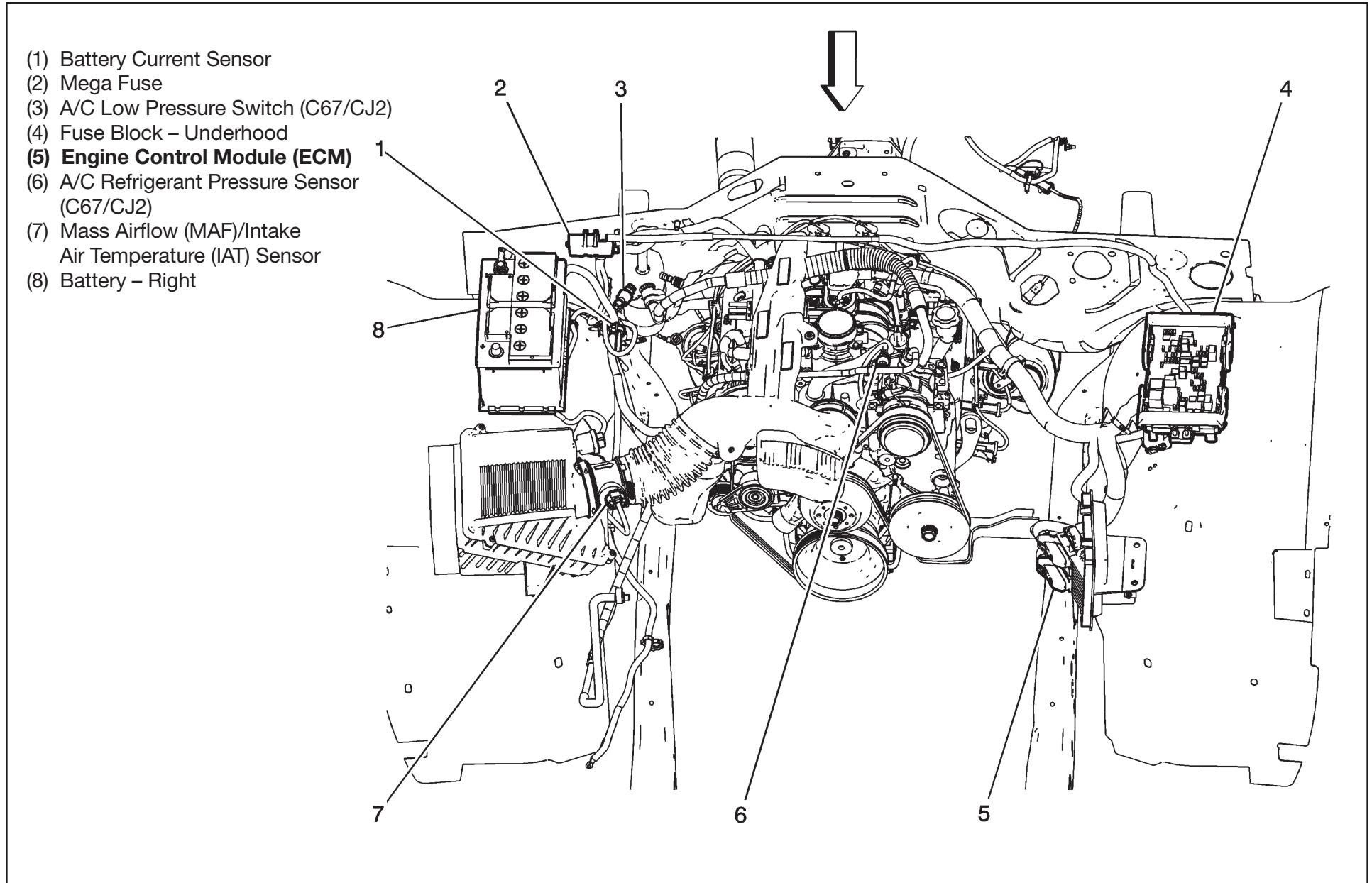

Engine Control Module (ECM) – 4.8L, 5.3L & 6.0L Gas – Connector X-1

Connector: 73-Way F Receptacle 0.64 Sealed (BK)
 O.E.M.: 15499466
 Color: **BLK**
 Service: 88988931

Pin	Wire Color	Circuit No.	Function
1	OG/BK	1786	Park/Neutral Signal
2	GY/BK	1694	4WD Low Signal
3-8	--	--	Not Used
9	L-BU/WH	6311	Cruise/ETC/TCC Brake Signal
10	PU/WH	1668	HO2S High Signal [- Bank 1 Sensor X]
11	TN/WH	1669	HO2S Low Signal [- Bank 1 Sensor X]
12	OG/BK	380	A/C Refrigerant Pressure Sensor Signal
13	TN	5514	Low Reference
14-15	--	--	Not Used
16	PU	1589	Fuel Level Sensor Signal [- Primary]
17	D-BU/WH	473	High Speed Cooling Fan Relay Control
18	D-BU	5985	Accessory Wakeup Serial Data
19	PK	439	Ignition 1 Voltage
20	RD/WH	440	Battery Positive Voltage
21-22	--	--	Not Used
23	PU	1272	Low Reference
24	D-GN	890	Fuel Tank Pressure Sensor Signal
25-26	--	--	Not Used
27	TN	2501	High Speed GMLAN Serial Data Bus -
28	TN/BK	2500	High Speed GMLAN Serial Data Bus +
29	D-BU	1161	APP Sensor 1 Signal
30	BN	1271	Low Reference
31	TN/BK	6049	Fuel Tank Sensor Low Reference
32	L-BU	1162	APP Sensor 2 Signal
33	GY	2709	5-Volt Reference
34	GY/WH	2700	A/C Pressure Sensor 5-Volt Reference
35	--	--	Not Used

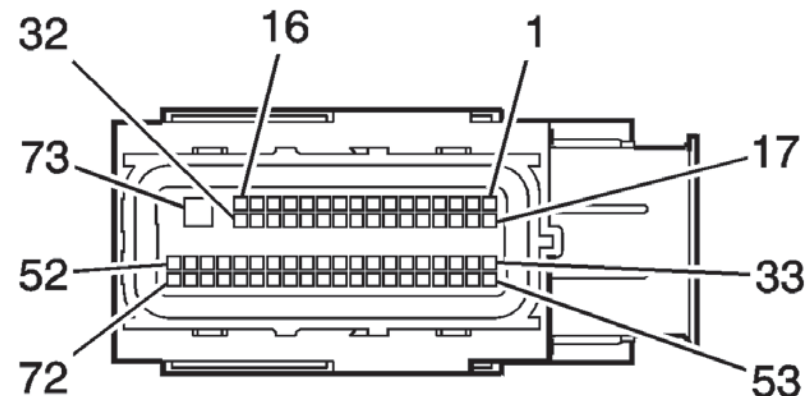
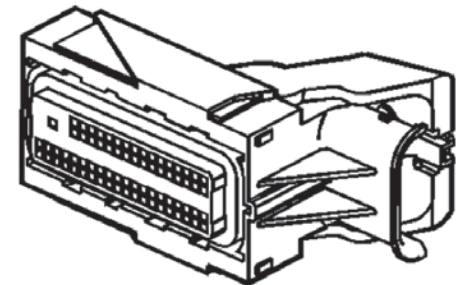

(chart continued on next page)

Engine Control Module (ECM) - 4.8L, 5.3L & 6.0L Gas - Connector X-1 (continued)

chart continued from previous page

Pin	Wire Color	Circuit No.	Function
36	TN	1274	5-Volt Reference
37	TN/BK	472	IAT Sensor Signal
38	TN	2760	Low Reference
39-40	--	--	Not Used
41	YE	492	MAF Sensor Signal
42-46	--	--	Not Used
47	PK/BK	1339	Ignition 1 Voltage
48	--	--	Not Used
49	TN	1671	HO2S Low Signal [- Bank 2 Sensor 2]
50	D-GN/WH	465	Fuel Pump Relay Control [- Primary]
51	TN	1465	Fuel Pump Relay Control [- Secondary]
52	YE/BK	625	Starter Enable Relay Control
53-55	--	--	Not Used
56	WH/BK	1164	5-Volt Reference
57	YE/BK	1827	Vehicle Speed Signal
58	D-GN	335	Low Speed Cooling Fan Relay Control

Pin	Wire Color	Circuit No.	Function
59	YE	5991	Powertrain Relay Coil Control
60	--	--	Not Used
61	WH	1310	EVAP Canister Vent Solenoid Control
62	--	--	Not Used
63	D-GN/WH	459	A/C Compressor Clutch Relay Control
64	OG/WH	3223	HO2S Heater Low Control (Bank 2 Sensor 2)
65	GY/WH	3122	HO2S Heater Low Control [- Bank 2 Sensor 1]
66-67	--	--	Not Used
68	BN/WH	419	MIL Control
69	PU	1670	HO2S High Signal [- Bank 2 Sensor 2]
70	L-BU	1937	Secondary Fuel Level Sensor Signal
71	OG/BK	6399	Replicated TOS Signal
72	--	--	Not Used
73	BK/WH	451	Ground

Engine Control Module (ECM) - 4.8L, 5.3L & 6.0L Gas - Connector X-2

Connector: 80-Way F Receptacle 0.64 2.8 Sealed (GY)
 O.E.M.: 13511426
 Color: **GY**
 Service: 19115670

Pin	Wire Color	Circuit No.	Function
1	---	---	Not Used
2	PU/WH	6270	5-Volt Reference
3	GY	2701	5-Volt Reference
4	---	---	Not Used
5	BN	582	TAC Motor Control - 2
6	YE	581	TAC Motor Control - 1
7	---	---	Not Used
8	D-GN/WH	428	EVAP Canister Purge Solenoid Control
9	GY	5493	Cylinder Shutoff Solenoid Control (3)
10	D-BU	5491	Cylinder Shutoff Solenoid Control (1)
11	OG	5494	Cylinder Shutoff Solenoid Control (4)
12	GY/WH	3113	HO2S Heater Low Control [- Bank 1 Sensor 1]
13	L-GN	3212	HO2S Heater Low Control [- Bank 2 Sensor 1]
14	L-GN/BK	5492	Cylinder Shutoff Solenoid Control (2)
15	---	---	Not Used
16	PU	5284	Camshaft Actuator Solenoid Control (AFM)
17	D-BU/WH	878	Fuel Injector 8 Control
18	TN/WH	845	Fuel Injector 5 Control
19	YE/BK	846	Fuel Injector 6 Control
20	TN	1744	Fuel Injector 1 Control
21	YE	410	ECT Sensor Signal
22	TN	2761	Low Reference
23-25	---	---	Not Used
26	D-BU	496	Knock Sensor [1] Signal

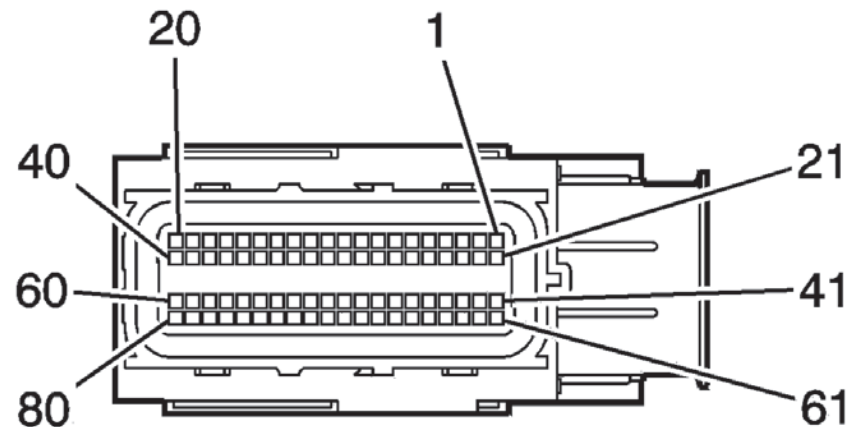
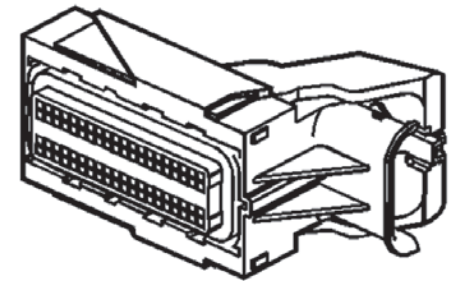

(chart continued on next page)

Engine Control Module (ECM) - 4.8L, 5.3L & 6.0L Gas - Connector X-2 (continued)

chart continued from previous page

Pin	Wire Color	Circuit No.	Function
27	GY	1716	Low Reference
28	--	--	Not Used
29	L-BU	1876	Knock Sensor 2 Signal
30	GY	2303	Low Reference
31	--	--	Not Used
32	GY	23	Generator Field Duty Cycle Signal
33	BN	1174	Oil Level Switch Signal
34	BK	2755	Low Reference
35	TN	2752	Low Reference
36	--	--	Not Used
37	L-GN/BK	1745	Fuel Injector 2 Control
38	PK/BK	1746	Fuel Injector 3 Control
39	L-BU/BK	844	Fuel Injector 4 Control
40	OG/BK	877	Fuel Injector 7 Control
41	GY	2705	5-Volt Reference
42	--	--	Not Used
43	GY	2704	5-Volt Reference
44	D-BU	6259	5-Volt Reference
45-49	--	--	Not Used
50	TN/WH	331	Oil Pressure Sensor Signal
51	--	--	Not Used
52	TN	2199	Low Reference
53	OG/BK	469	Low Reference
54-55	--	--	Not Used
56	TN	1664	HO2S Low Signal [- Bank 1 Sensor 1]

Pin	Wire Color	Circuit No.	Function
57	PU/WH	1665	HO2S High Signal [- Bank 1 Sensor 1]
58	L-GN	432	MAP Sensor Signal
59	PU	1666	HO2S High Signal [- Bank 2 Sensor 1]
60	TN	1667	HO2S Low Signal [- Bank 2 Sensor 1]
61	BN	25	Charge Indicator Control/Charge Indicator Signal
62	--	--	Not Used
63	PU	486	TP Sensor 2 Signal
64	D-BU/WH	6265	Camshaft CAM W Signal
65	D-GN	485	TP Sensor 1 Signal
66	BN	6266	Camshaft CAM W Ground
67	--	--	Not Used
68	WH/BK	6271	Crankshaft 60X Sensor Signal
69	GY/BK	6272	Crankshaft 60X Sensor Low Reference
70	PU	2121	IC 1 Control
71	PU/WH	2128	IC 8 Control
72	OG	2127	IC 7 Control
73	OG/WH	2122	IC 2 Control
74	L-BU/WH	2126	IC 6 Control
75	D-GN	2125	IC 5 Control
76	D-GN/WH	2124	IC 4 Control
77	L-BU	2123	IC 3 Control
78	BN	2129	Low Reference
79	BN/WH	2130	Low Reference
80	--	--	Not Used

Engine Control Module (ECM) - 4.8L, 5.3L & 6.0L Gas - Location

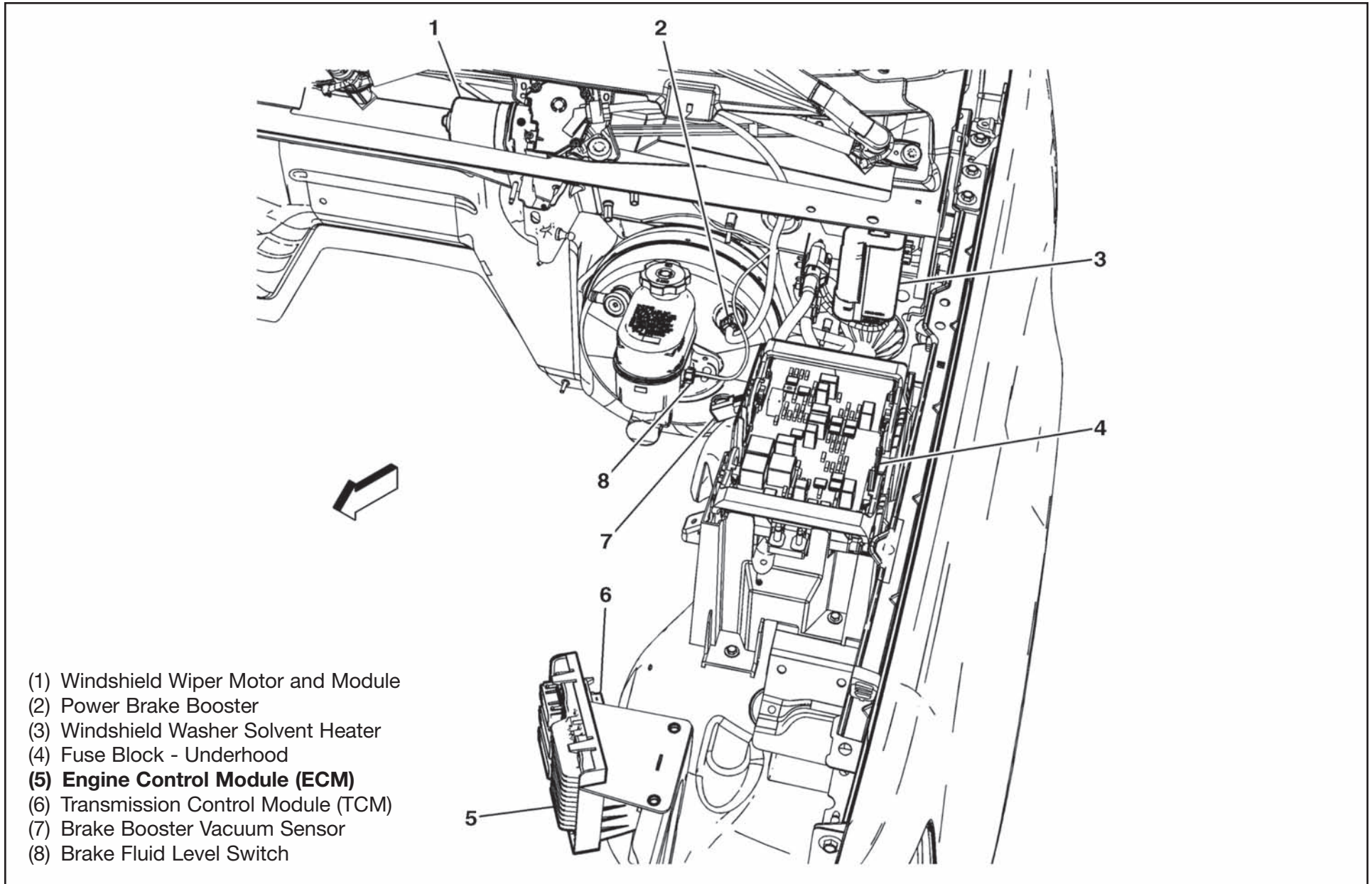

Engine Control Module (ECM): LMM 6.6L Diesel - Connector X-1

OEM: 15438366
 Service: 19149311
 Description: 96-Way F Sealed
 Color: **BLK**

Pin	Wire Color	Circuit No.	Function
1	1 OG	5421	Fuel Injector Supply Voltage 1
2	1 D-BU/WH	878	Fuel Injector 8
3	1 OG/BK	877	Fuel Injector 7 Control
4	0.5 D-BU	2364	Cooling Fan Speed Signal
5	0.5 YE	492	MAF Sensor Signal
6	0.5 OG/BK	469	Low Reference
7-8	--	--	Not Used
9	0.5 BN	1174	Oil Level Switch Signal
10	--	--	Not Used
11	0.5 GY/BK	6272	Low Reference
12	0.5 GY	2704	5-Volt Reference 3
13	0.5 TN	5928	5-Volt Reference 3
14	0.5 GY	6054	5-Volt Reference 2
15	0.5 GY	2705	5-Volt Reference 2
16	--	--	Not Used
17	0.5 GY	2701	5-Volt Reference 1
18	--	--	Not Used
19	0.5 L-GN	432	MAP Sensor Signal
20	0.5 YE	5947	Turbocharger Vane Position Sensor Signal
21	0.5 L-BU	1162	APP Sensor 2 Signal
22	--	--	Not Used
23	0.5 BK	2755	Low Reference

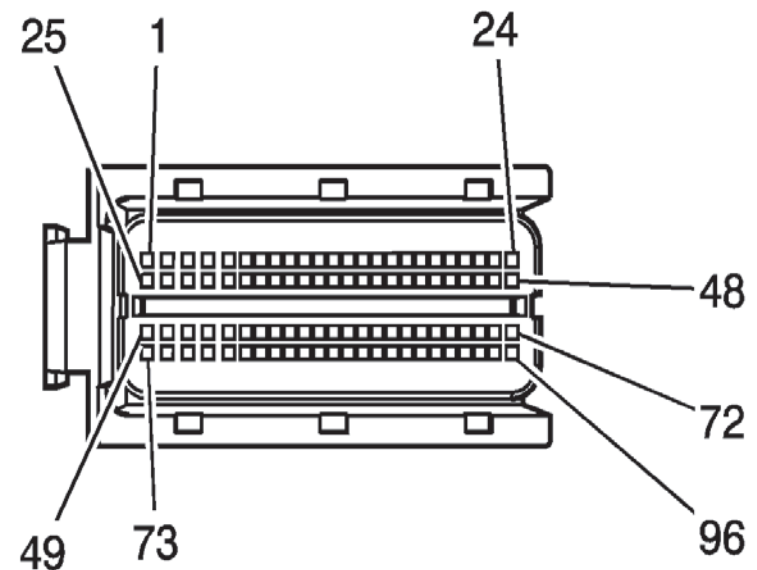
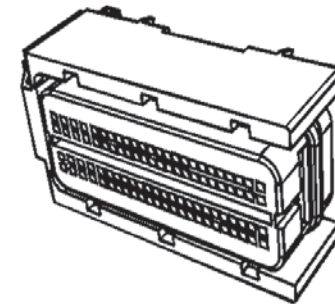

(chart continued on next page)

Engine Control Module (ECM): LMM 6.6L Diesel – Connector X-1 (continued)

chart continued from previous page

Pin	Wire Color	Circuit No.	Function
24	0.5 PU/WH	2530	Fuel Pressure Regulator Solenoid Supply Voltage
25	1 PK	5425	Fuel Injector Supply Voltage 4
26	1 YE/BK	846	Fuel Injector 6 Control
27	1 PK/BK	1746	Fuel Injector 3 Control
28	0.5 WH/BK	2366	Cooling Fan Clutch Control
29	--	--	Not Used
30	0.5 OG/BK	2919	Low Reference
31-32	--	--	Not Used
33	0.5 GY/BK	2931	Low Reference
34	--	--	Not Used
35	0.5 YE/BK	6055	Low Reference
36	0.5 TN	2752	Low Reference
37	0.5 GY	2702	5-Volt Reference 3
38	0.5 TN	1274	5-Volt Reference 2
39	0.5 TN	2917	5-Volt Reference 2
40	0.5 PU/WH	6270	5-Volt Reference 1
41	0.5 D-BU	6259	5-Volt Reference 1
42	0.5 TN	472	IAT Sensor Signal
43	0.5 D-BU	6053	DPF Sensor Signal
44	0.5 TN/WH	331	Oil Pressure Sensor Signal
45	0.5 L-GN	2032	ECT Sensor Signal
46	--	--	Not Used
47	0.5 TN	2761	Low Reference
48	0.5 D-BU	5930	Turbocharger Vane Position Control Solenoid Valve Control

Pin	Wire Color	Circuit No.	Function
49	1 PU	5423	Fuel Injector Supply Voltage 3
50	1 TN/WH	845	Fuel Injector 5 Control
51	1 L-BU/BK	844	Fuel Injector 4 Control
52	--	--	Not Used
53	0.5 YE/BK	6120	Low Reference
54-55	--	--	Not Used
56	0.5 D-BU/WH	6265	CMP Sensor Signal
57	0.5 GY/BK	1694	4WD Low Signal (NQG)
58-61	--	--	Not Used
62	0.5 TN	2760	Low Reference
63	0.5 OG/BK	5929	Low Reference
64	0.5 L-BU/BK	6813	Low Reference
65	0.5 L-BU	6118	Air Temperature Sensor Signal
66	--	--	Not Used
67	0.5 BN/WH	5763	EGR Valve Sensor Signal
68	0.5 YE	410	ECT Sensor Signal
69	0.5 D-BU	5277	Exhaust Gas Temperature Sensor
70	0.5 BN	6782	Low Reference
71	0.5 YE/BK	625	Starter Enable Relay Control
72	0.5 YE	2834	Fuel Pressure Regulator Solenoid Control
73	1 YE	5422	Fuel Injector Supply Voltage 2
74	1 TN	1744	Fuel Injector 1 Control
75	1 L-GN/BK	1745	Fuel Injector 2 Control
76	0.5 PK	1339	Ignition 1 Voltage

(chart continued on next page)

Engine Control Module (ECM): LMM 6.6L Diesel – Connector X-1 (continued)

chart continued from previous page

Pin	Wire Color	Circuit No.	Function
77	0.5 RD/WH	440	Battery Positive Voltage
78	0.5 PU	1272	Low Reference
79	0.5 WH/BK	6271	CKP Sensor Signal
80-81	--	--	Not Used
82	0.5 TN/WH	1695	Axle Switch Signal (NQG)
83	0.5 L-BU/ WH	6311	TCC Brake Signal
84	0.5 D-GN/ WH	6142	Power Take Off Engine Shutdown Signal (PTO)
85	0.5 YE/BK	508	Low Reference
86	0.5 TN	2753	Low Reference
87	0.5 GY/BK	5765	Fuel Filter Pressure Switch Signal
88	0.5 BN	6266	Low Reference
89-90	--	--	Not Used
91	0.5 D-GN	485	TP Sensor Signal
92	0.5 YE	2918	FRP Sensor Signal
93	0.5 L-BU	5377	Exhaust Gas Temperature Sensor
94	0.5 BN/WH	6783	Low Reference
95	--	--	Not Used
96	0.5 WH	5931	Low Reference

Engine Control Module (ECM): LMM 6.6L Diesel - Connector X-2

OEM: 15462694
 Service: 88988935
 Description: 58-Way F Mixed Series Sealed
 Color: **BLK**

Pin	Wire Color	Circuit No.	Function
1	2 PK	1439	Ignition 1 Voltage
2	2 BK/WH	451	Ground
3	2 PK	1439	Ignition 1 Voltage
4	2 BK/WH	451	Ground
5	2 PK	1439	Ignition 1 Voltage
6	2 BK/WH	451	Ground
7	0.8 BN	582	Motor Control - 2
8	0.8 BN	25	Charge Indicator Control
9-11	--	--	Not Used
12	0.5 D-GN/WH	465	Fuel Pump Relay Control
13	0.5 TN	5514	Low Reference (CJ2/C67)
14	--	--	Not Used
15	0.5 WH/BK	1164	5-Volt Reference 3
16	0.5 D-BU	507	Wait to Start Indicator Control
17-18	--	--	Not Used
19	0.5 YE	5991	Powertrain Relay Coil Control
20	0.8 YE	581	Motor Control - 1
21	0.5 PK	439	Ignition 1 Voltage
22-25	--	--	Not Used
26	0.5 BN/WH	6141	Low References
27	0.5 GY	2700	5-Volt Reference 2 (CJ2/C67)

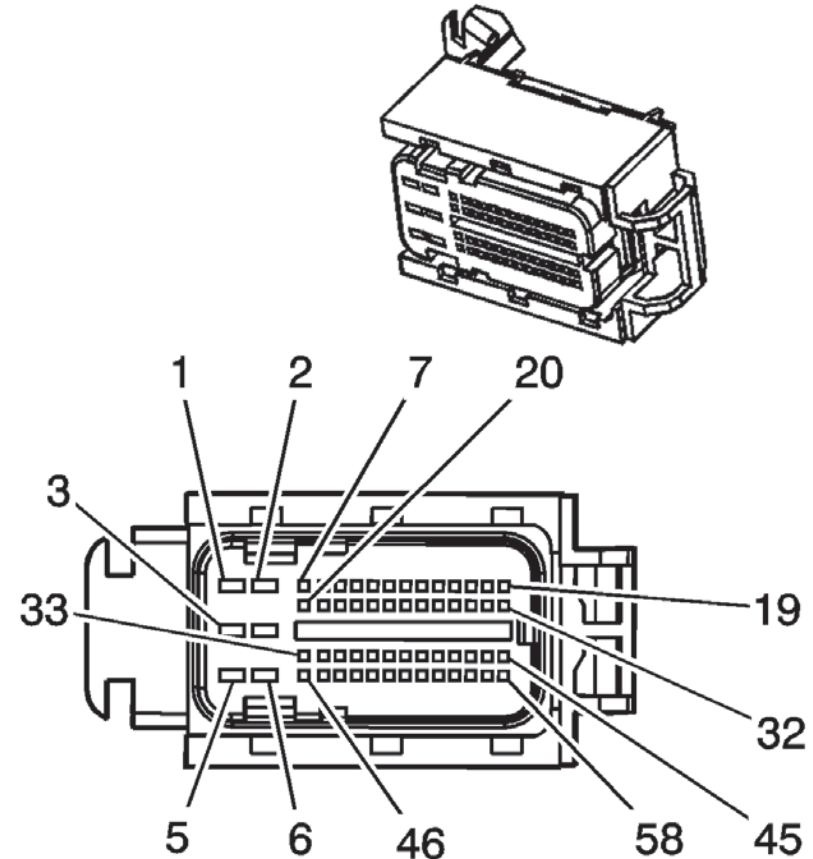

(chart continued on next page)

Engine Control Module (ECM): LMM 6.6L Diesel – Connector X-2 (continued)

chart continued from previous page

Pin	Wire Color	Circuit No.	Function
28	0.5 GY	2365	5-Volt Reference
29	0.5 BN	1271	Low Reference
30	0.5 BN/WH	419	MIL Control
31	0.5 D-GN/WH	459	A/C Compressor Clutch Relay Control (CJ2/C67)
32	--	--	Not Used
33	0.5 OG/BK	5764	Exhaust Gas Recirculation Valve Motor High Signal
34	0.5 TN/BK	6049	Low Reference
35	0.5 OG/BK	380	A/C Refrigerant Pressure Sensor Signal (CJ2/C67)
36	0.5 PU	1589	Fuel Level Sensor Signal
37	--	--	Not Used
38	0.8 GY	23	Generator Field Duty Cycle Signal
39	0.5 OG/BK	1786	Park/Neutral Signal
40-43	--	--	Not Used

Pin	Wire Color	Circuit No.	Function
44	0.5 TN	2501	High Speed GMLAN Serial Data Bus (-)
45	0.5 OG/BK	6399	VSS High Signal
46	0.5 L-GN/BK	5746	EGR Valve Motor Low Control
47	0.5 BN	6062	Low Reference
48	0.5 YE	1578	Fuel Temperature Sensor Signal
49	0.5 D-BU	1161	APP Sensor 1 Signal
50	0.5 L-BU	1937	Secondary Fuel Level Sensor Signal (-NQZ)
51-53	--	--	Not Used
54	0.5 YE/BK	1827	Vehicle Speed Signal
55	--	--	Not Used
56	0.5 D-BU	5985	Accessory Wakeup Serial Data
57	0.5 TN/BK	2500	High Speed GMLAN Serial Data Bus (+)
58	--	--	Not Used

Engine Control Module (ECM): LMM 6.6L Diesel – Location

- (1) Battery – Right
- (2) Fuse Holder – Underhood
- (3) X127
- (4) X108
- (5) X107
- (6) X123 (PTO)
- (7) Fuse Block – Underhood
- (8) X109
- (9) Battery – Left (6A6/TP2)
- (10) Engine Control Module (ECM)**
- (11) Transmission Control Module (TCM)

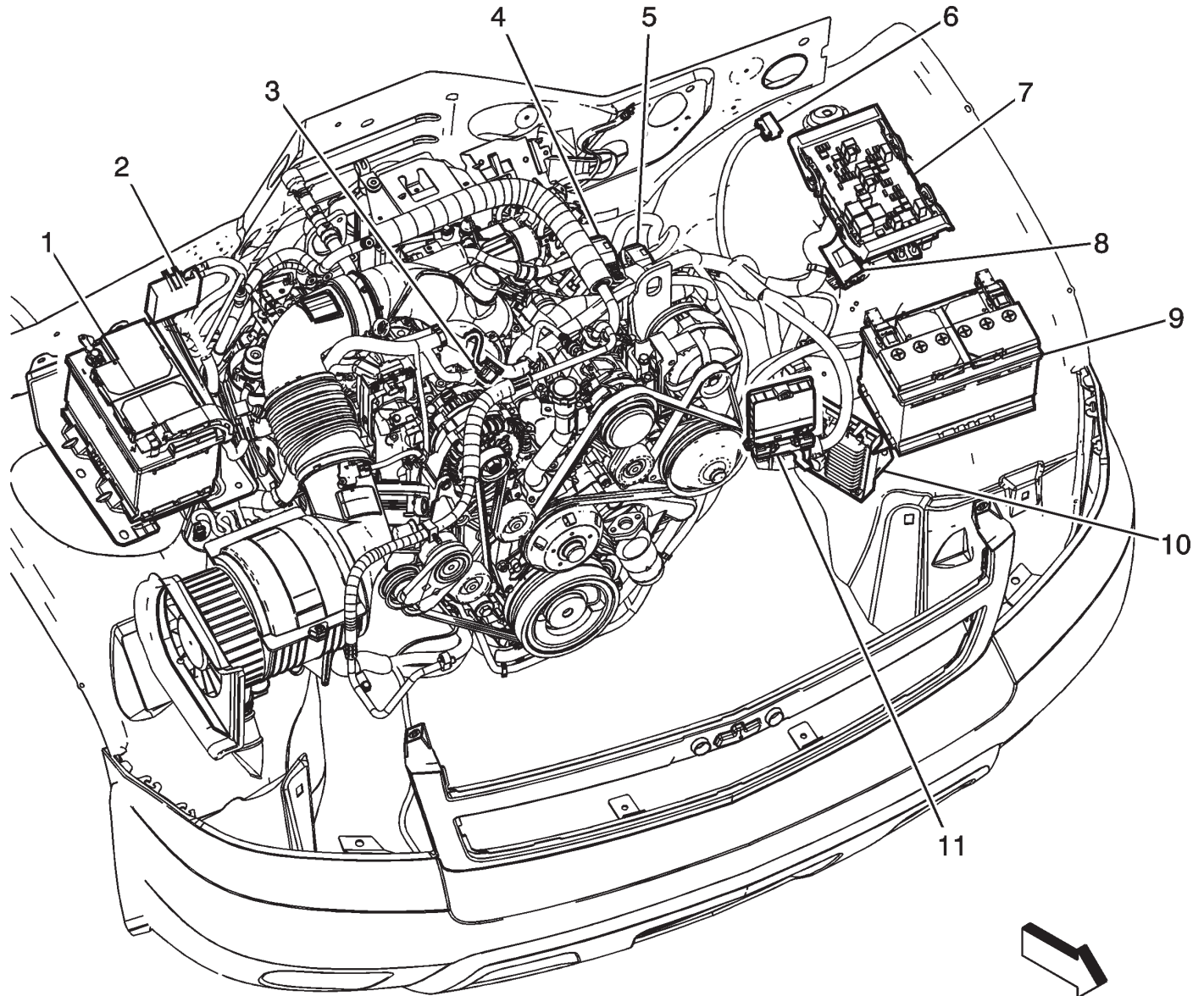

X124 - Engine Harness to PTO Jumper Harness (PTO)

9.2. Connector Pin Functions

Pin	Circuit Number*	Wire Color*	Description
A	6085	BN/WH	Remote Engine Start Input
B	494	L-BU	Remote Engine Shutdown Input
C	978	GY	PTO Remote Enable Input
D	550	BK	Power Ground
E	975	WH	+5 volt Sensor/Switch Reference (50 ma)
F	6142	D-GN/WH	PTO Switch Reference Output (300 ma)
G	2522	YE	PTO Load Feedback
H	2562	PU	PTO Relay Low-Side Control Output
J	6381	BN	PTO Relay High-Side Control Output
K	2640	RD/WH	Battery (10 Amp Fused) Output
L	6089	D-BU/WH	PTO Remote Set A Input
M	976	GY/BK	Ground Reference
N	977	L-BU	PTO Remote Accelerator Input
P	979	D-BU	Remote Start Arming
R	239	PK	Ignition (Switched Run/Crank)
S	981	TN	PTO Remote Indicator Lamp/Remote Tachometer (MY2009 Vehicles only)

* Vehicle harness Circuit Number and Wire Color

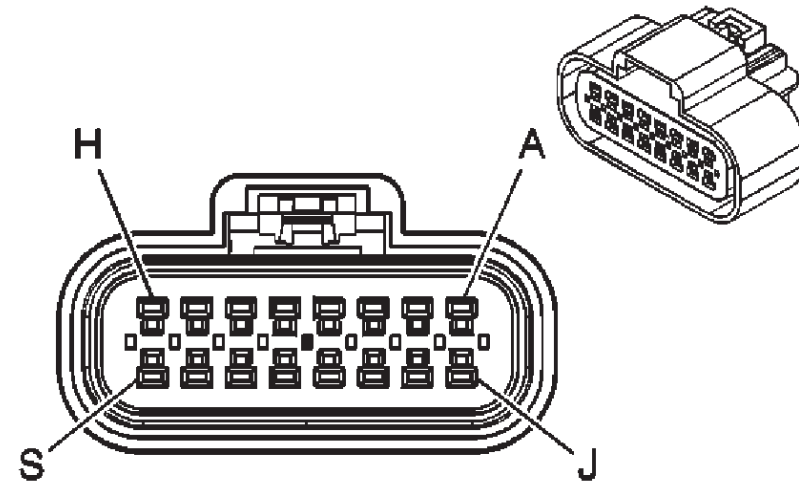

OEM: 15326863
 Service: 1530638
 Description: 16-Way F GT 150 Sealed (BK)

	Part Number	Type	Description
Terminal Seals, and Locks	15358785	Lock	Purple Secondary Lock
	15366060	Seal	Blue Individual Loose Cable Seal
	15305171	Seal	Green Cable Cavity Cavity Plug
	15366021	Seal	White Individual Loose Cable Seal
	15326268	Terminal	Male GT 150 Tin Plated Terminal, Cable Range 0.50 - 0.35 mm ² , Cable Insulation Range 1.85 - 1.20 mm
	15326269	Terminal	Male GT 150 Tin Plated Terminal, Cable Range 1.00 - 0.75 mm ² , Cable Insulation Range 2.25 - 1.70 mm

X124 – PTO Connector Location

- (1) X300
- (2) G300
- (3) Automatic Transmission Turbine Speed Sensor
- (4) Automatic Transmission Input Shaft Speed (AT ISS) Sensor
- (5) Automatic Transmission
- (6) Vehicle Speed Sensor (VSS)
- (7) X124**
- (8) Power Take Off (PTO) Module**
- (9) X175

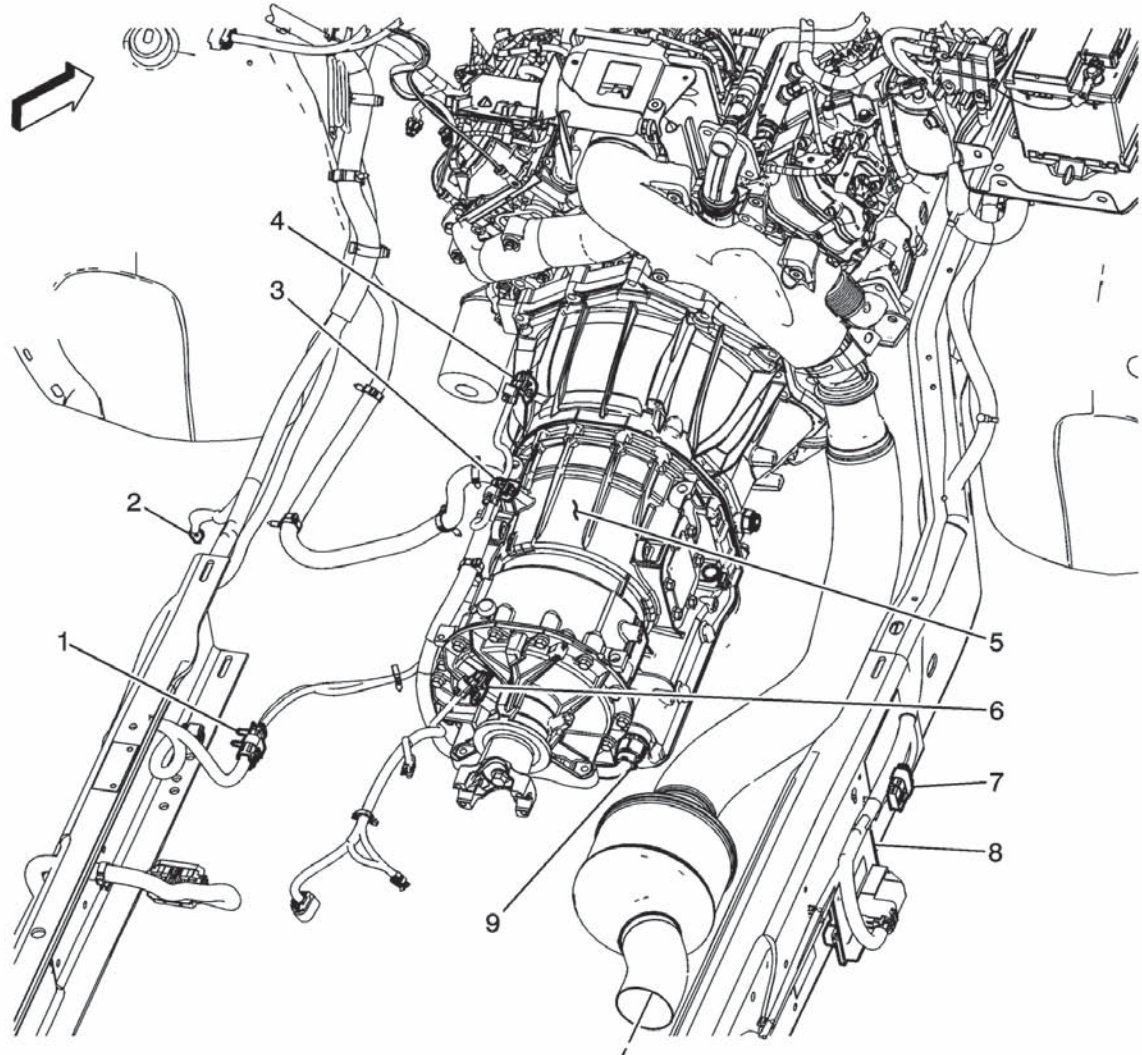

Rear Lighting - Utility - C411 Chassis Harness to Left Rear Lamp Harness (Except E52/Z75)

Connector: 4-Way F GT 150 Series, Sealed (BK)
 O.E.M.: 15326815
 Color: **BLK**
 Service: 15306396

Pin	Wire Color	Circuit No.	Function
A	YE	--	Left Rear Stop/Turn Lamp Supply Voltage
B	BK	--	Ground
C	BN	--	Left Rear Park Lamps Supply Voltage
D	L-GN	--	Backup Lamp Supply Voltage

Connector: 4-Way M GT 150 Series, Sealed (BK)
 O.E.M.: 15326820
 Color: **BLK**
 Service: 15326820

Pin	Wire Color	Circuit No.	Function
A	YE	18	Left Rear Stop/Turn Lamp Supply Voltage
B	BK	1750	Ground
C	BN	2509	Left Rear Park Lamps Supply Voltage
D	L-GN	24	Backup Lamp Supply Voltage

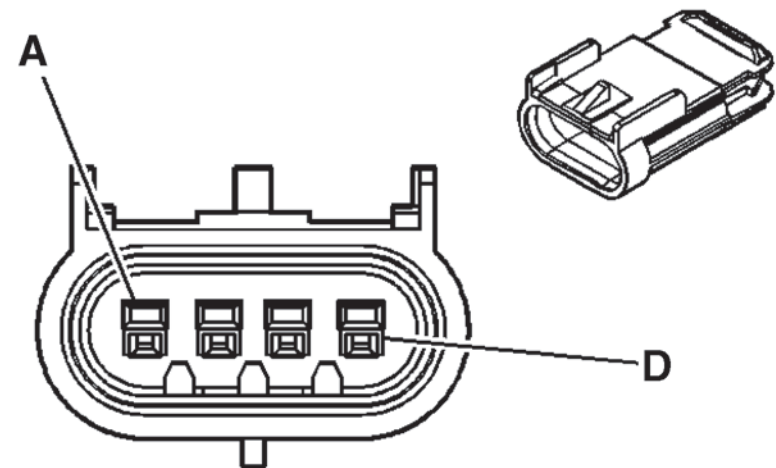
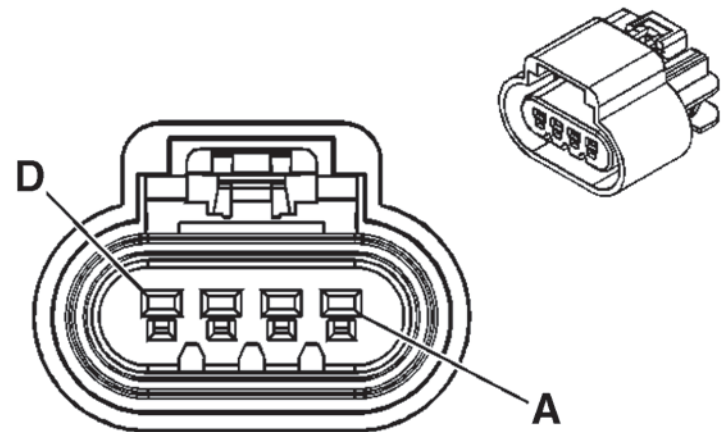

Rear Lighting - Utility - C411 Chassis Harness to Left Rear Lamp Harness (E52 Except Z75)

Connector: 5-Way F GT 150 Series, Sealed (BK)
 O.E.M.: 15326822
 Color: **BLK**
 Service: 88987186

Pin	Wire Color	Circuit No.	Function
A	YE/BK	--	Left Rear Turn Signal Lamp Supply Voltage
B	L-BU	--	Stop Lamp Supply Voltage
C	BK	--	Ground
D	BN	--	Left Rear Park Lamps Supply Voltage
E	L-GN	--	Backup Lamp Supply Voltage

Connector: 5-Way M GT 150 Series, Sealed (BK)
 O.E.M.: 15326827
 Color: **BLK**
 Service: 89046648

Pin	Wire Color	Circuit No.	Function
A	YE/BK	1334	Left Rear Turn Signal Lamp Supply Voltage
B	L-BU	20	Stop Lamp Supply Voltage
C	BK	1750	Ground
D	BN	2509	Left Rear Park Lamps Supply Voltage
E	L-GN	24	Backup Lamp Supply Voltage

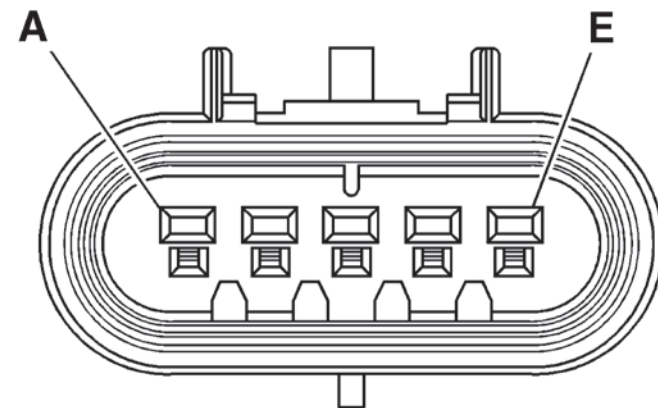
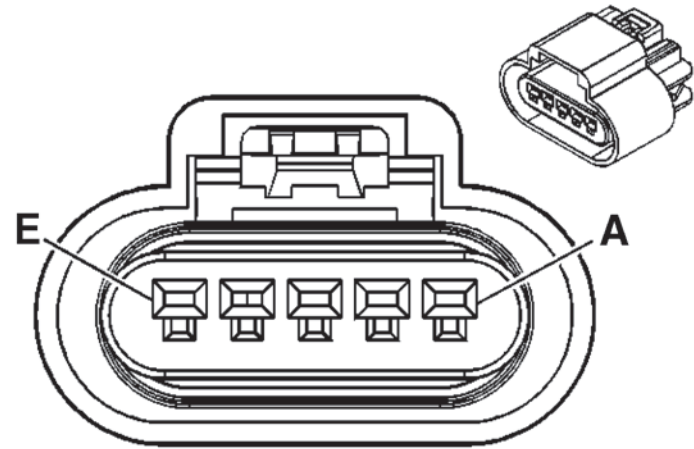

Rear Lighting - Utility - C411 Chassis Harness to Left Rear Lamp Harness (Z75)

Connector: 6-Way F GT 150 Series, Sealed (BK)
 O.E.M.: 15326829
 Color: **BLK**
 Service: 88953153

Pin	Wire Color	Circuit No.	Function
A	YE/BK	--	Left Rear Turn Signal Lamp Supply Voltage
B	YE	--	Left Rear Stop/Turn Lamp Supply Voltage
	L-BU	--	Stop Lamp Supply Voltage
C	BK	--	Ground
D	BN	--	Left Rear Park Lamps Supply Voltage
E	L-GN	--	Backup Lamp Supply Voltage
	OG	--	Rear Fog Lamp Supply Voltage
F	YE	--	Left Tail Lamp Outage Detection Signal

Connector: 6-Way M GT 150 Series, Sealed (BK)
 O.E.M.: 15326833
 Color: **BLK**
 Service: 15326833

Pin	Wire Color	Circuit No.	Function
A	YE/BK	1334	Left Rear Turn Signal Lamp Supply Voltage
B	YE	18	Left Rear Stop/Turn Lamp Supply Voltage
	L-BU	20	Stop Lamp Supply Voltage
C	BK	1750	Ground
D	BN	2509	Left Rear Park Lamps Supply Voltage
E	L-GN	24	Backup Lamp Supply Voltage
	OG	122	Rear Fog Lamp Supply Voltage
F	YE	5356	Left Tail Lamp Outage Detection Signal

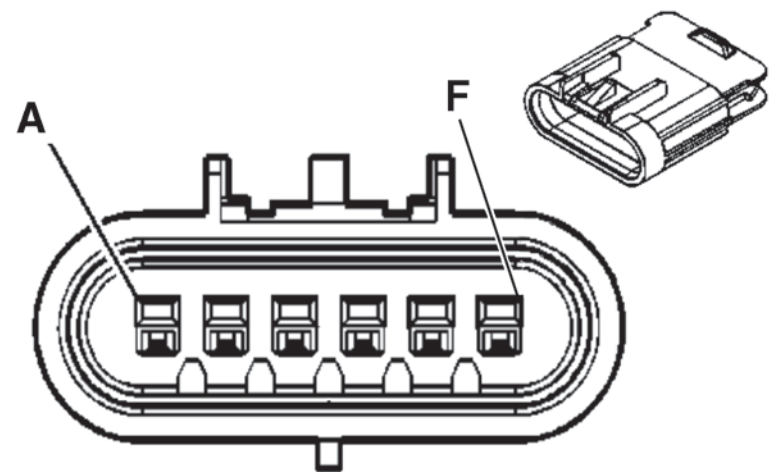
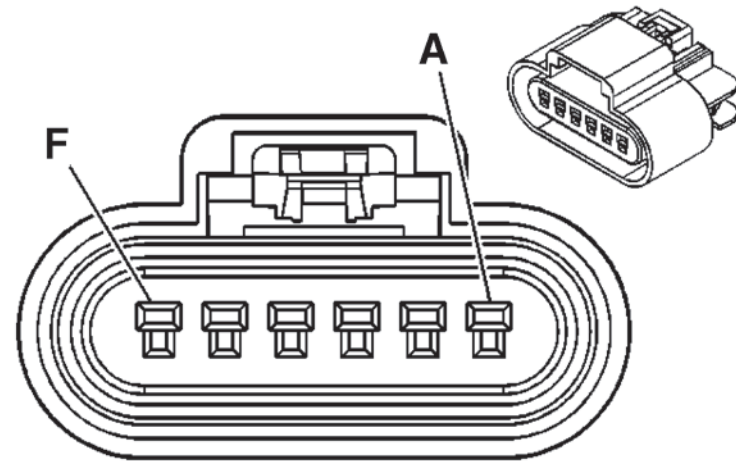

Rear Lighting - Utility - C412 Chassis Harness to Right Rear Lamp Harness (Except E52/Z75)

Connector: 4-Way F GT 150 Series, Sealed (BK)
 O.E.M.: 15326815
 Color: **BLK**
 Service: 15306396

Pin	Wire Color	Circuit No.	Function
A	D-GN	--	Right Rear Stop/Turn Lamp Supply Voltage
B	BK	--	Ground
C	BN	--	Right Rear Park Lamps Supply Voltage
D	L-GN	--	Backup Lamp Supply Voltage

Connector: 4-Way M GT 150 Series, Sealed (BK)
 O.E.M.: 15326820
 Color: **BLK**
 Service: 15326820

Pin	Wire Color	Circuit No.	Function
A	D-GN	19	Right Rear Stop/Turn Lamp Supply Voltage
B	BK	1750	Ground
C	BN	2609	Right Rear Park Lamps Supply Voltage
D	L-GN	24	Backup Lamp Supply Voltage

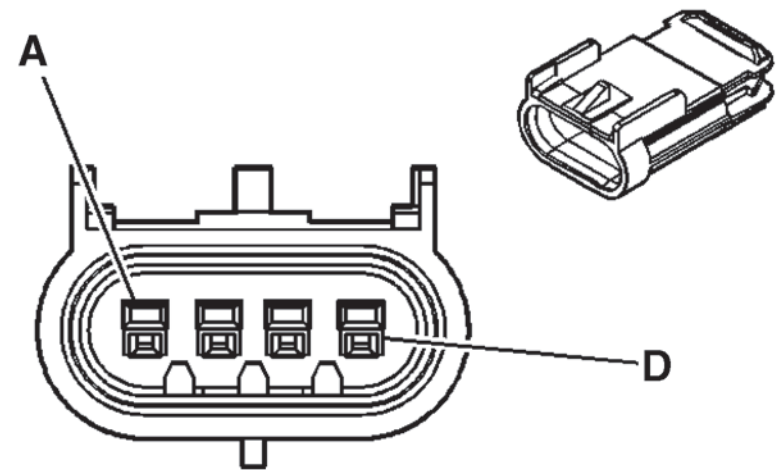
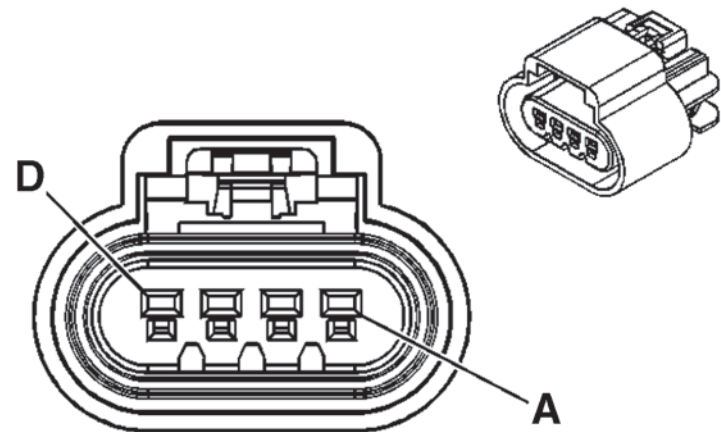

Rear Lighting - Utility - C412 Chassis Harness to Right Rear Lamp Harness (E52 Except Z75)

Connector: 5-Way F GT 150 Series, Sealed (BK)
 O.E.M.: 15326822
 Color: **BLK**
 Service: 88987186

Pin	Wire Color	Circuit No.	Function
A	D-GN/WH	--	Right Rear Turn Signal Lamp Supply Voltage
B	L-BU/BK	--	Stop Lamp Supply Voltage
C	BK	--	Ground
D	BN	--	Right Rear Park Lamps Supply Voltage
E	L-GN	--	Backup Lamp Supply Voltage

Connector: 5-Way M GT 150 Series, Sealed (BK)
 O.E.M.: 15326827
 Color: **BLK**
 Service: 89046648

Pin	Wire Color	Circuit No.	Function
A	D-GN/WH	1335	Right Rear Turn Signal Lamp Supply Voltage
B	L-BU/BK	20	Stop Lamp Supply Voltage
C	BK	1750	Ground
D	BN	2609	Right Rear Park Lamps Supply Voltage
E	L-GN	24	Backup Lamp Supply Voltage

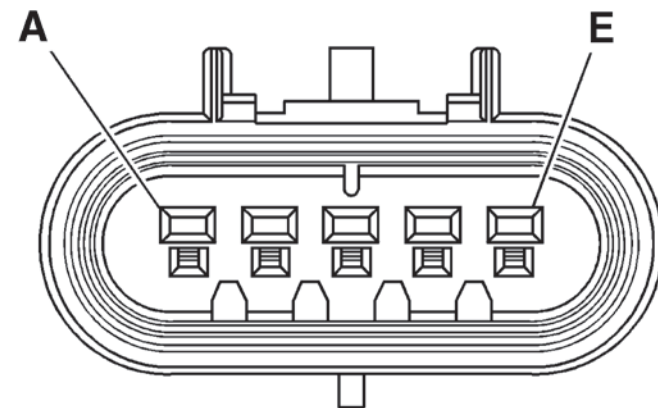
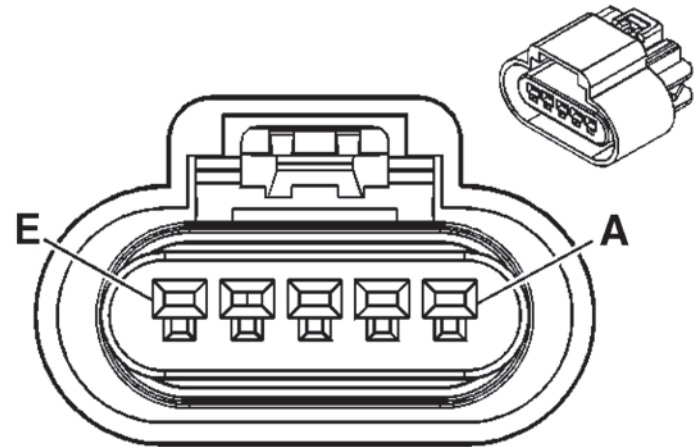

Rear Lighting - Utility - C412 Chassis Harness to Right Rear Lamp Harness (Z75)

Connector: 6-Way F GT 150 Series, Sealed (BK)
 O.E.M.: 15326829
 Color: **BLK**
 Service: 88953153

Pin	Wire Color	Circuit No.	Function
A	D-GN/WH	--	Right Rear Turn Signal Lamp Supply Voltage
B	D-GN	--	Right Rear Stop/Turn Lamp Supply Voltage
	L-BU/BK	--	Stop Lamp Supply Voltage
C	BK	--	Ground
D	BN	--	Right Rear Park Lamps Supply Voltage
E	L-GN	--	Backup Lamp Supply Voltage
F	PU	--	Right Tail Lamp Outage Detection Signal

Connector: 6-Way M GT 150 Series, Sealed (BK)
 O.E.M.: 15326833
 Color: **BLK**
 Service: 15326833

Pin	Wire Color	Circuit No.	Function
A	D-GN/WH	1335	Right Rear Turn Signal Lamp Supply Voltage
B	D-GN	19	Right Rear Stop/Turn Lamp Supply Voltage
	L-BU/BK	20	Stop Lamp Supply Voltage
C	BK	1750	Ground
D	BN	2609	Right Rear Park Lamps Supply Voltage
E	L-GN	24	Backup Lamp Supply Voltage
F	PU	5357	Right Tail Lamp Outage Detection Signal

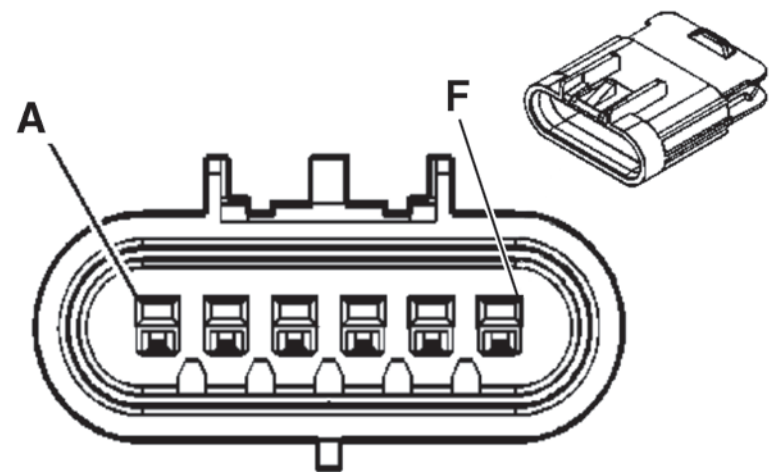
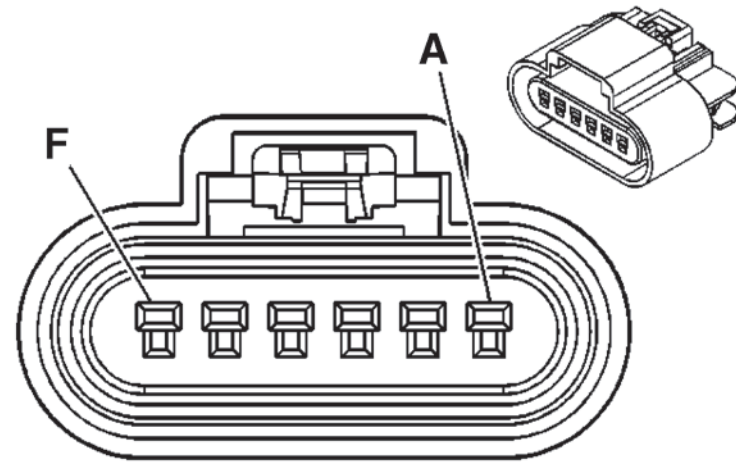

Rear Lighting - Utility - C411 and C412 Location - Short Wheel Base

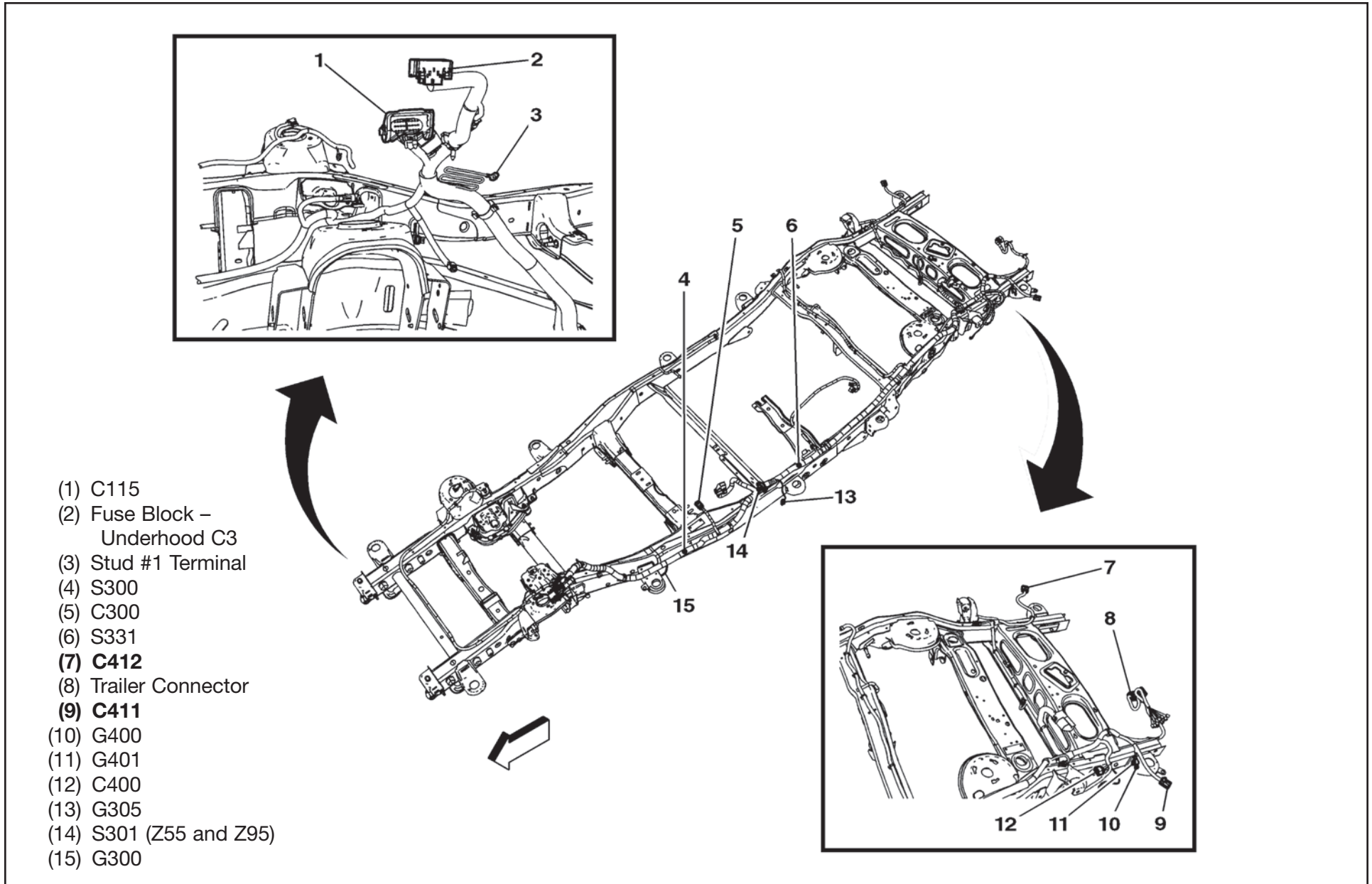

Rear Lighting - Utility - C411 and C412 Location - Long Wheel Base

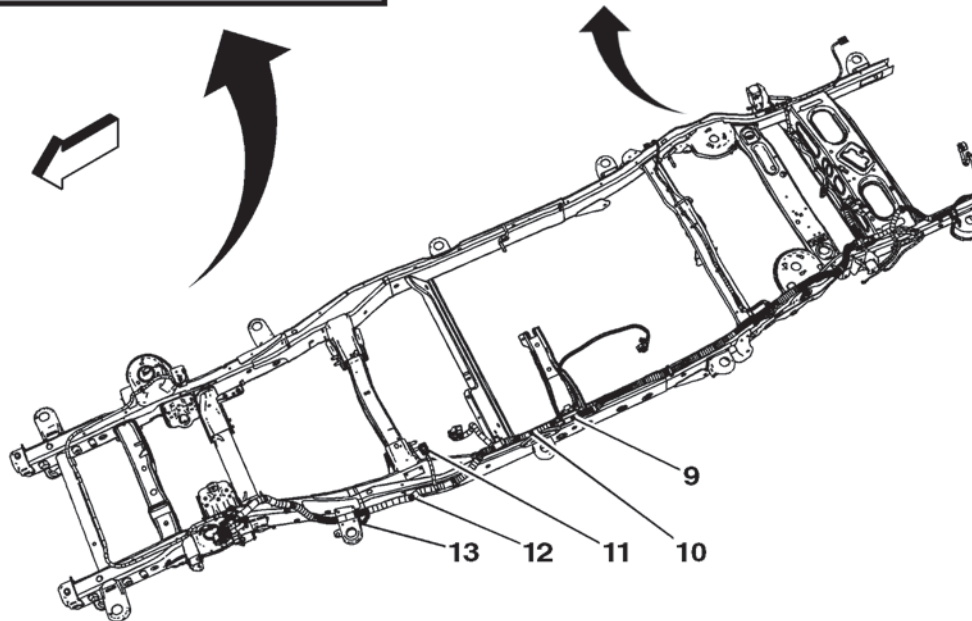
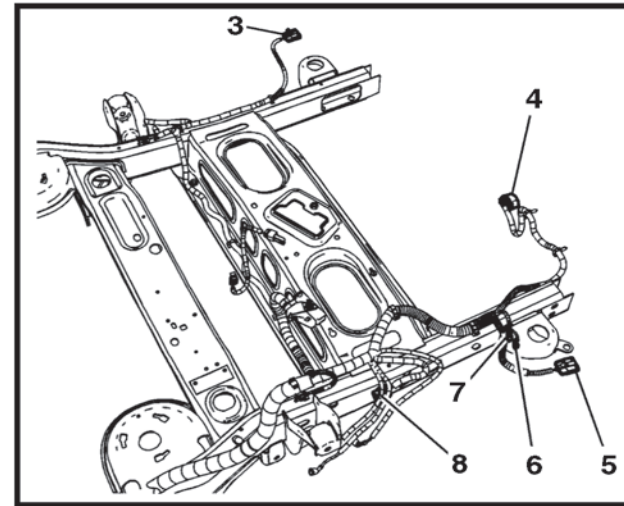
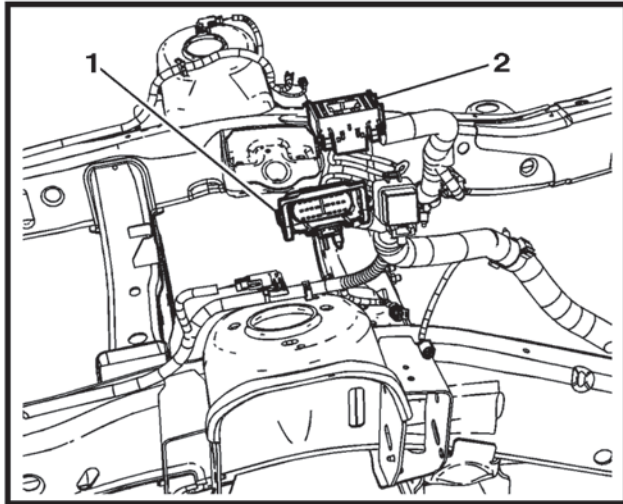

- (1) C115
- (2) Fuse Block -
Underhood C3
- (3) C412**
- (4) Trailer Connector
- (5) C411**
- (6) G400
- (7) G401
- (8) C400 (Z55)
- (9) S331
- (10) S301 (Z55 and Z95)
- (11) C300
- (12) S300
- (13) G300

Rear Lighting - Utility - Rear of the Vehicle (X88 w/E52)

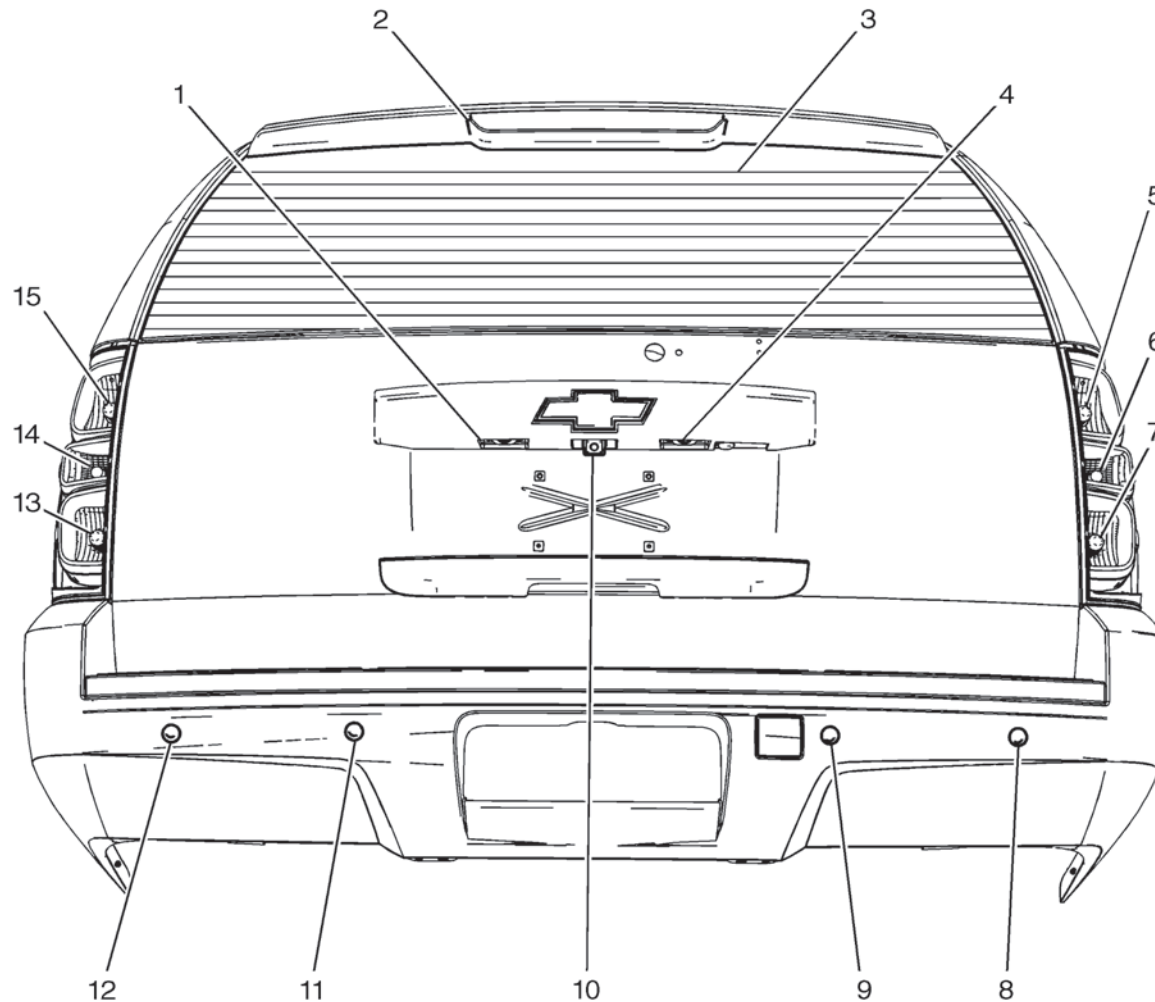

- (1) License Lamp - Left
- (2) Center High Mounted Stop Lamp (CHMSL)
- (3) Defogger Grid
- (4) License Lamp - Right
- (5) Tail/Stop Lamp - Right

- (6) Backup Lamp - Right
- (7) Tail/Turn Signal Lamp - Right
- (8) Object Sensor - RR Corner
- (9) Object Sensor - RR Middle
- (10) Rearview Camera (UVC) (E52)

- (11) Object Sensor - LR Middle
- (12) Object Sensor - LR Corner
- (13) Tail/Turn Signal Lamp - Left
- (14) Backup Lamp - Left
- (15) Tail/Stop Lamp - Left

Rear Lighting – Utility – Rear of the Vehicle (X88 Except E52)

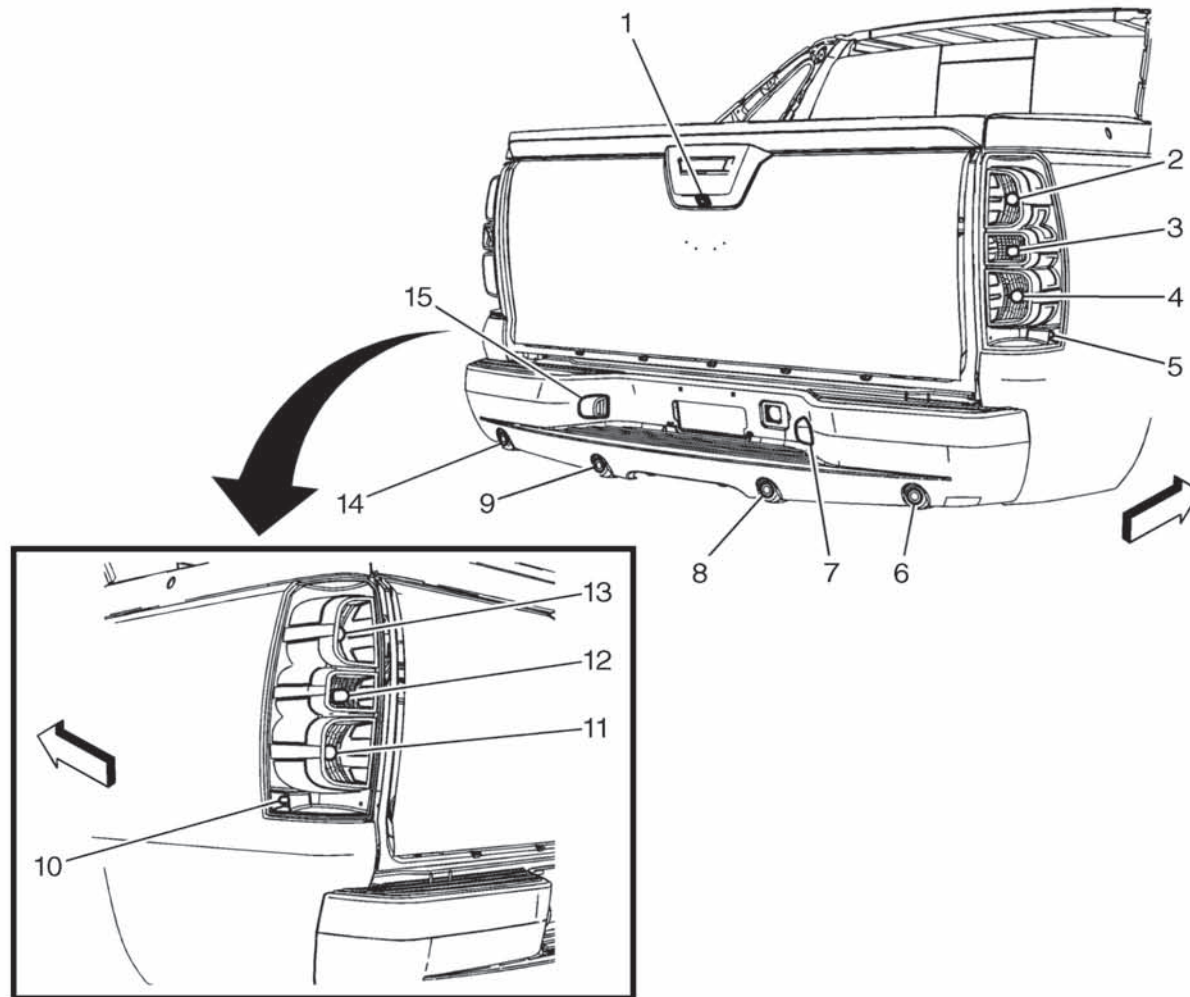

- (1) Rearview Camera (UVC)
- (2) Tail/Stop Lamp – Right
- (3) Backup Lamp – Right
- (4) Tail/Turn Signal Lamp – Right
- (5) Marker Lamp – RR

- (6) Object Sensor – RR Corner
- (7) License Lamp – Right
- (8) Object Sensor – RR Middle
- (9) Object Sensor – LR Middle
- (10) Marker Lamp – LR

- (11) Tail/Turn Signal Lamp – Left
- (12) Backup Lamp – Left
- (13) Tail/Stop Lamp Left
- (14) Object Sensor – LR Corner
- (15) License Lamp – Left

Rear Lighting – Pickup & Chassis Cab Junction Block C-1 – Rear Chassis Harness Connector

Connector	8-Way F Global Tech 280 Series (BLU)		
Typical Connector	15305595 (F)		
Color	BLU		
Typical Terminal	15304716		
Typical Cable Seal	15366061		
Pin	Wire Color	Circuit No.	Function
A	YEL	18	Left Stop/Turn Signal Lamps Supply Voltage
B	BLK	2150	Ground
C	LT GRN	24	Backup Lamp Supply Voltage
D	BRN/WHT	2609	Right Rear Park Lamps Supply Voltage
E	BLK	1750	Ground
F	--	--	Not Used
G	BRN	2509	Left Rear Park Lamps Supply Voltage
H	DK GRN	19	Right Stop/Turn Signal Lamps Supply Voltage

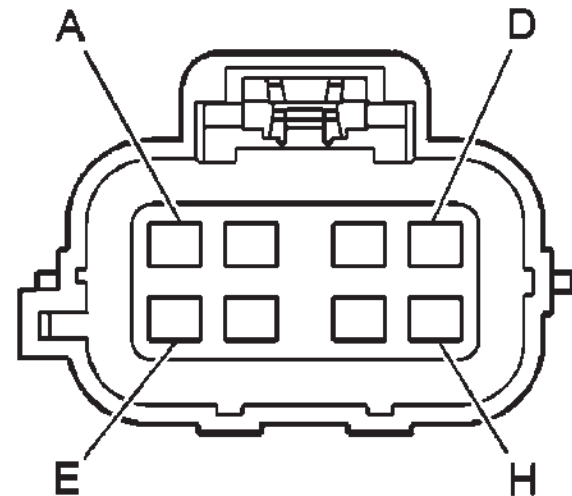
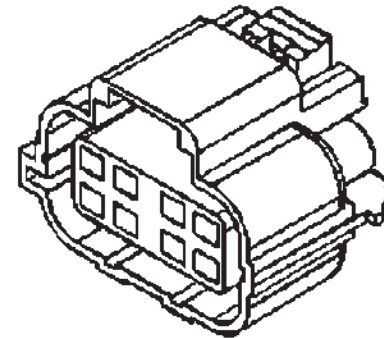

Rear Lighting – Pickup & Chassis Cab Junction Block C-2 – Left Tail Lamp Connector

Connector	7-Way F Global Tech 280 Series (GRY)		
Typical Connector	15305596 (F)		
Color	GRY		
Typical Terminal	15304716		
Typical Cable Seal	15366061		
Pin	Wire Color	Circuit No.	Function
A	---	---	Not Used
B	---	---	Not Used
C	BLK	1750	Ground
D	---	---	Not Used
E	BRN	2509	Left Rear Park Lamps Supply Voltage
F	LT GRN	24	Backup Lamp Supply Voltage
H	YEL	18	Left Stop/Turn Signal Lamps Supply Voltage

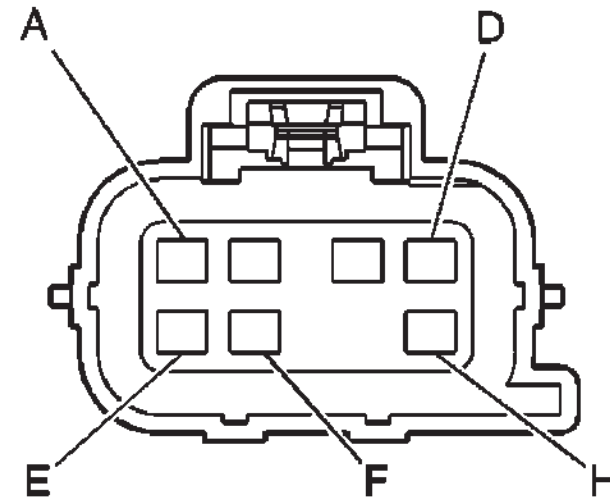
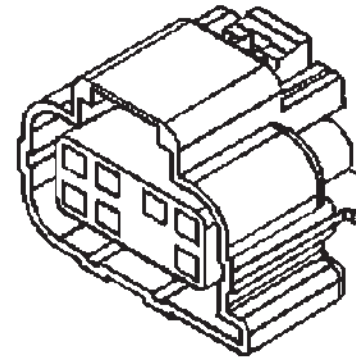

Rear Lighting – Pickup & Chassis Cab Junction Block C-3 – License Plate Connector

Connector	8-Way F Global Tech 280 Series (BRN)		
Typical Connector	15305599 (F)		
Color	BRN		
Typical Terminal	15304716		
Typical Cable Seal	15366061		

Pin	Wire Color	Circuit No.	Function
A	BRN/WHT	2609	Right Rear Park Lamps Supply Voltage
B	BRN/WHT	2609	Right Rear Park Lamps Supply Voltage
C	BLK	1750	Ground
D	BLK	1750	Ground
E	BLK	1750	Ground
F	BRN	2509	Left Rear Park Lamps Supply Voltage
G	BRN	2509	Left Rear Park Lamps Supply Voltage
H	BLK	1750	Ground

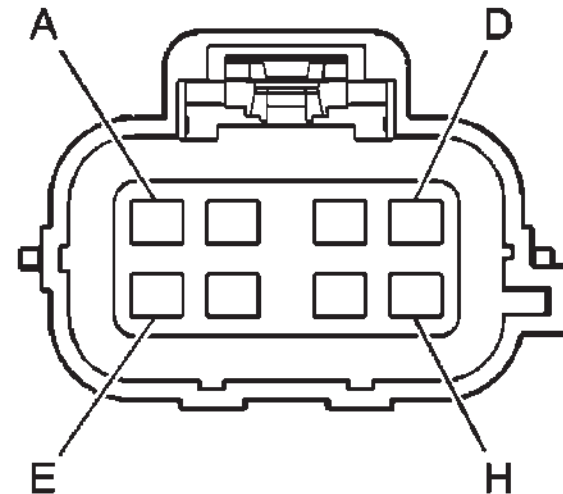
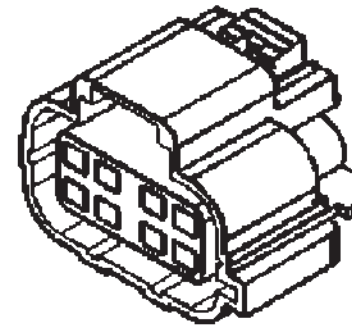

Rear Lighting – Pickup & Chassis Cab Junction Block C-4 – Right Tail Lamp Connector

Connector	7-Way F Global Tech 280 Series (BLK)
Typical Connector	15305597 (F)
Color	BLK
Typical Terminal	15304716
Typical Cable Seal	15366061

Pin	Wire Color	Circuit No.	Function
A	BLK	2150	Ground
B	BRN/WHT	2609	Right Rear Park Lamps Supply Voltage
C	---	---	Not Used
D	---	---	Not Used
E	LT GRN	24	Backup Lamp Supply Voltage
F	DK GRN	19	Right Stop/Turn Signal Lamps Supply Voltage
H	---	---	Not Used

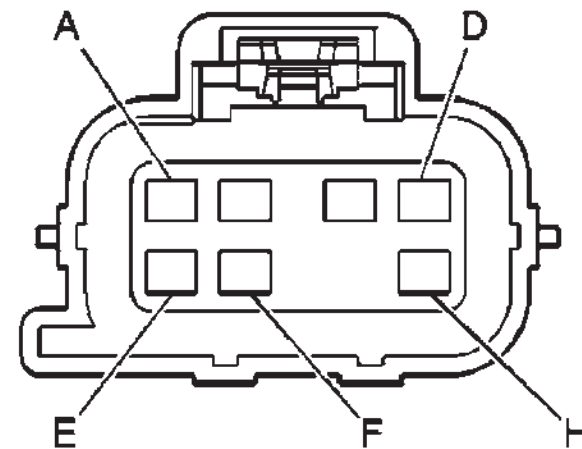
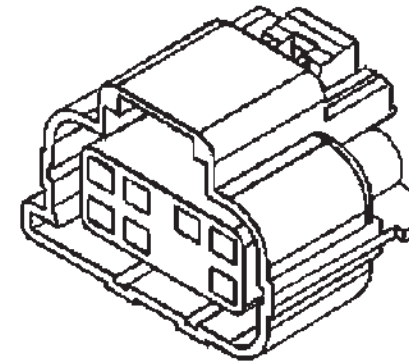

Rear Lighting – Pickup & Chassis Cab – Junction Block Location

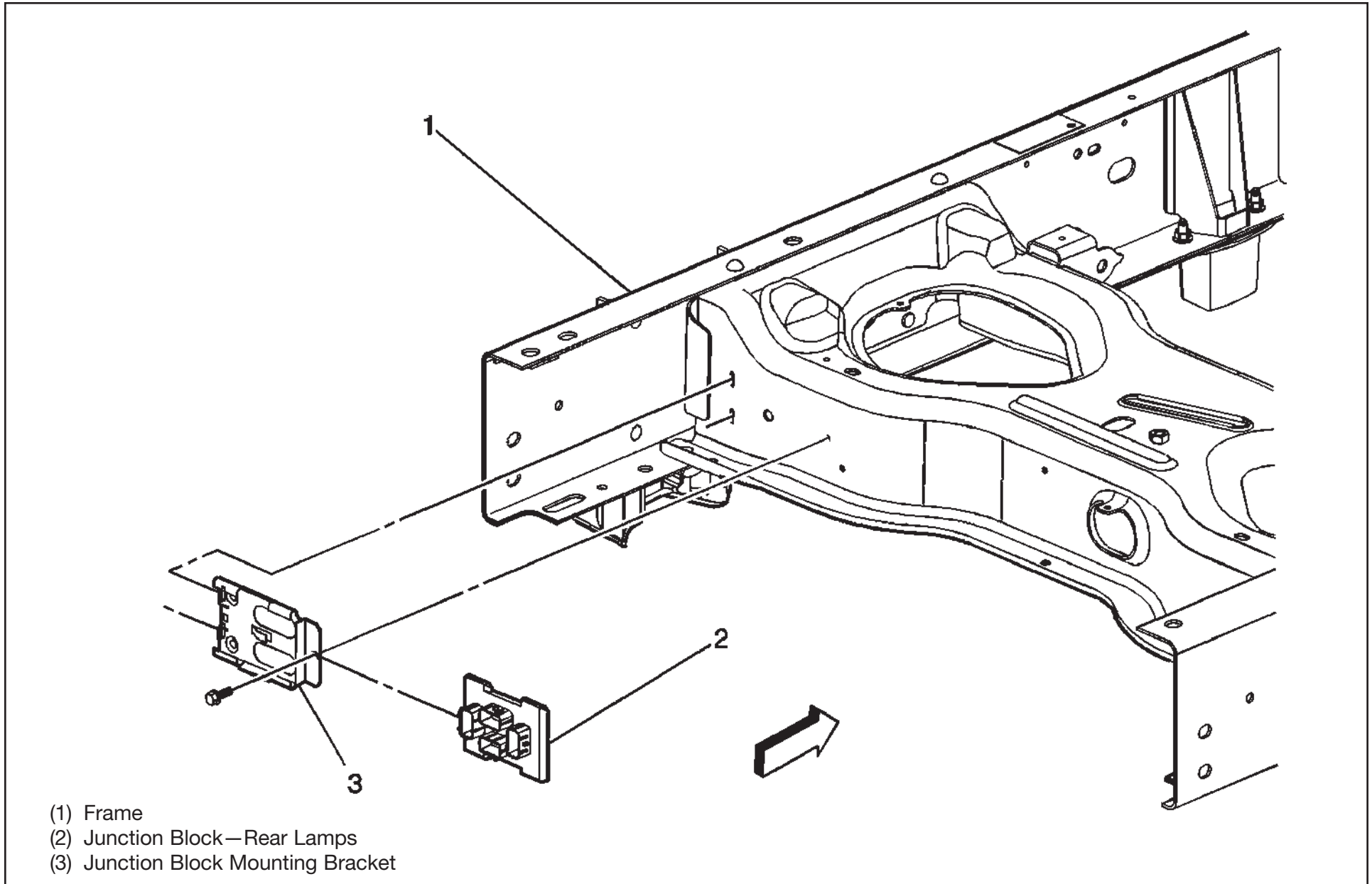

Rear Lighting - Pickup & Chassis-Cab - Rear of the Vehicle - Tail Lamp (X88)

- (1) Tail/Stop and Turn Signal Lamp - Upper Left
- (2) Tail/Stop and Turn Signal Lamp - Upper Right
- (3) Backup Lamp - Right Rear
- (4) Tail/Stop and Turn Signal Lamp - Lower Right
- (5) Object Sensor - Right Rear Corner (UD7)
- (6) License Lamp - Right
- (7) Object Sensor - Right Rear Middle (UD7)
- (8) Object Sensor - Left Rear Middle (UD7)
- (9) License Lamp - Left
- (10) Object Sensor - Left Rear Corner (UD7)
- (11) Tail/Stop and Turn Signal Lamp - Lower Left
- (12) Backup Lamp - Left Rear

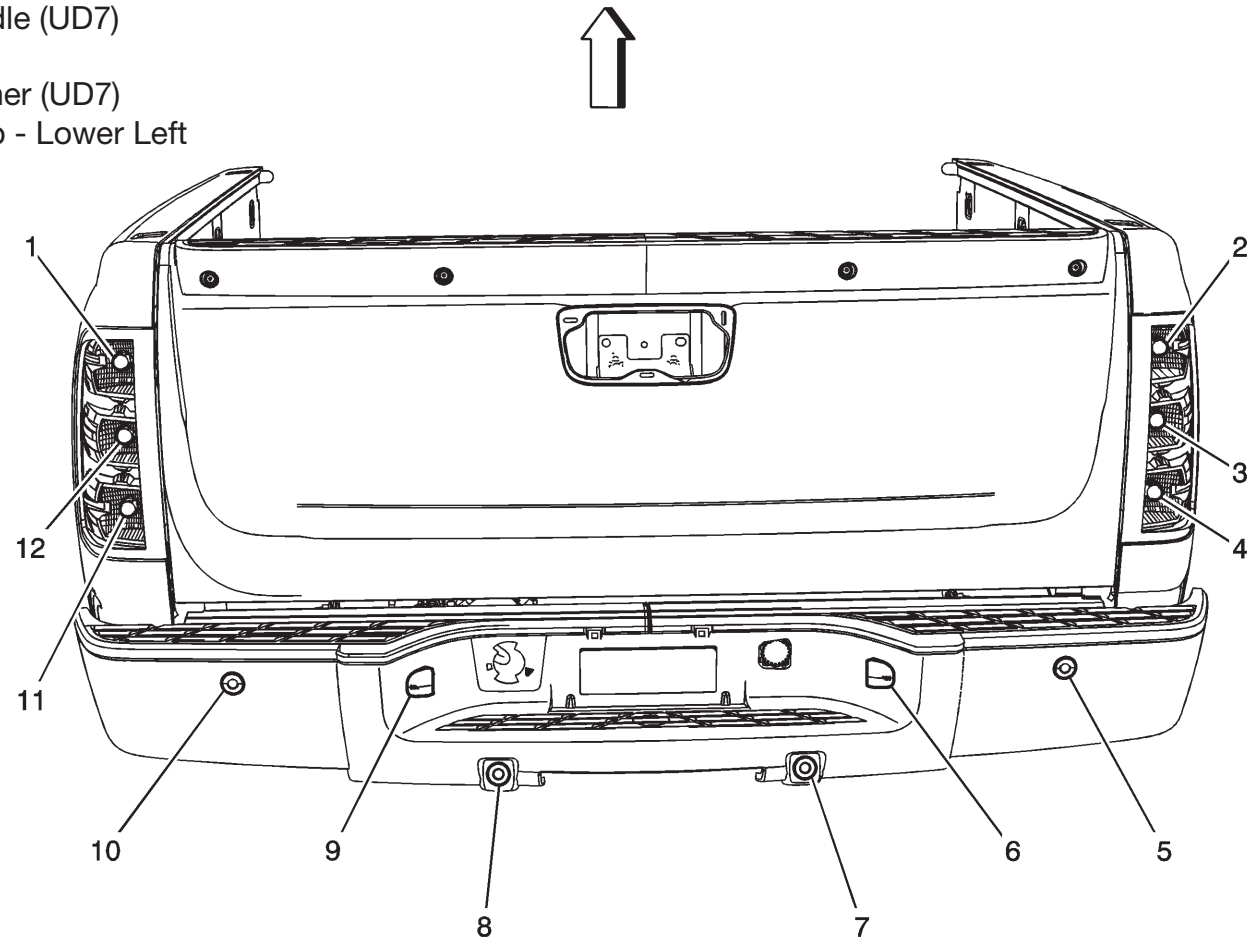

Rear Lighting - Pickup & Chassis-Cab - Rear of the Vehicle - Tail Lamp (Z88)

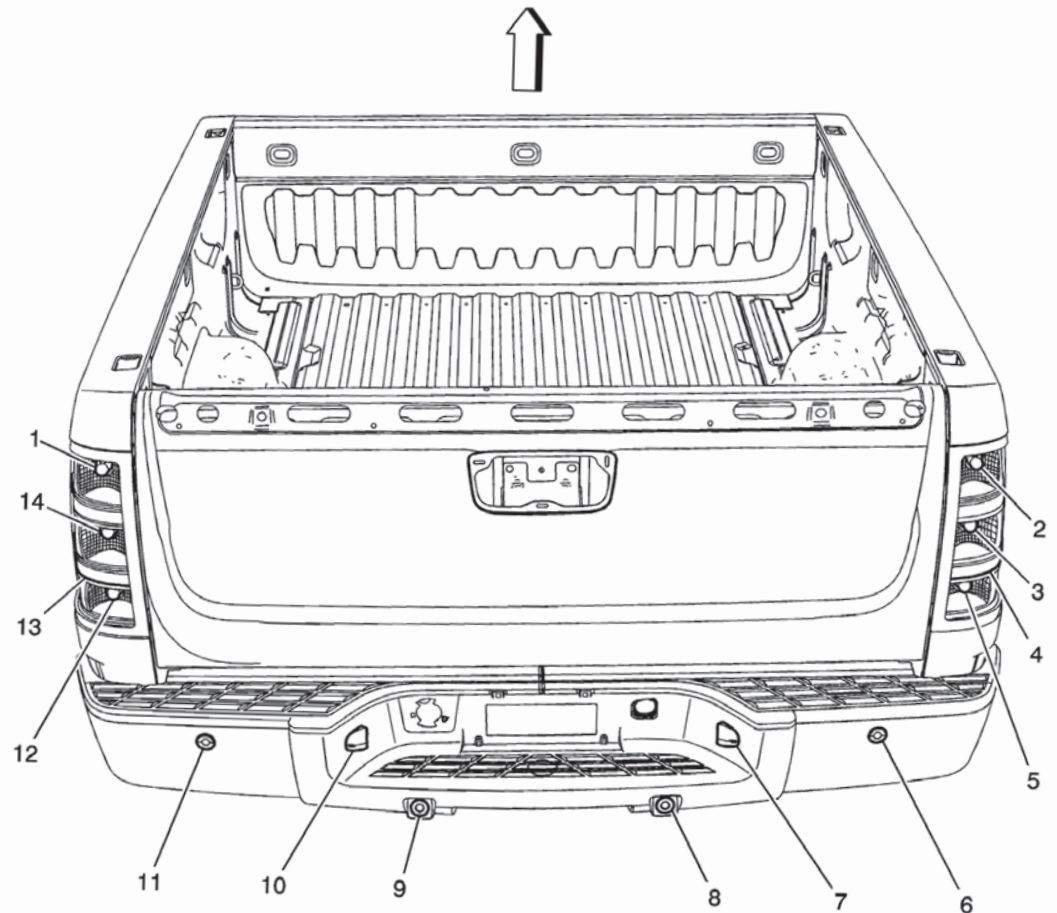

- (1) Tail/Stop and Turn Signal Lamp - Upper Left
- (2) Tail/Stop and Turn Signal Lamp - Upper Right
- (3) Tail/Stop and Turn Signal Lamp - Lower Right
- (4) Marker Lamp - Right Rear
- (5) Backup Lamp - Right Rear
- (6) Object Sensor - Right Rear Corner (UD7)
- (7) License Lamp - Right
- (8) Object Sensor - Right Rear Middle (UD7)
- (9) Object Sensor - Left Rear Middle (UD7)
- (10) License Lamp - Left
- (11) Object Sensor - Left Rear Corner (UD7)
- (12) Backup Lamp - Left Rear
- (13) Marker Lamp - Left Rear
- (14) Tail/Stop and Turn Signal Lamp - Lower Left

Trailer Connector

Connector: 7-Way F Metri-Pack 280 630 Series, Sealed
 OEM: 15354653
 Color: **BLK**
 Service: 15306164

Pins: B

Terminal/Tray: 12052456/3
 Core/Insulation Crimp: TBD
 Release Tool/Test Probe: TBD

Pins: A, D, F, G

Terminal/Tray: 12110847/4
 Core/Insulation Crimp: C/5
 Release Tool/Test Probe: 15315247/J-35616-4A (PU)

Pins: C, E

Terminal/Tray: 12110845/4
 Core/Insulation Crimp: F/5
 Release Tool/Test Probe: 15315247/J-35616-4A (PU)

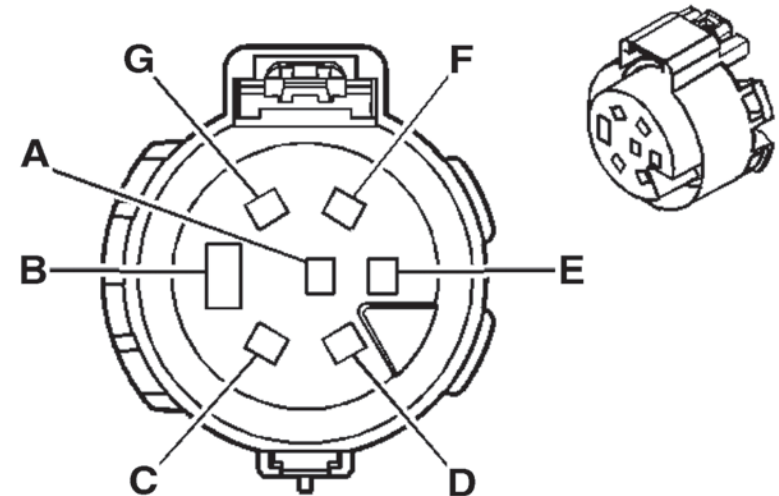

Pin	Wire Color	Circuit No.	Function
A	L-GN	1624	Trailer Backup Lamp Supply Voltage
B	WH	22	Ground
C	D-BU	47	Trailer Auxiliary Supply Voltage
D	D-GN	1619	Trailer Right Rear Turn/Stop Lamp Supply Voltage
E	RD/BK	742	Battery Positive Voltage
F	BN	2109	Trailer Park Lamp Supply Voltage
G	YE	1618	Trailer Left Rear Turn/Stop Lamp Supply Voltage

Trailer Connector Location – Pickup & Chassis-Cab

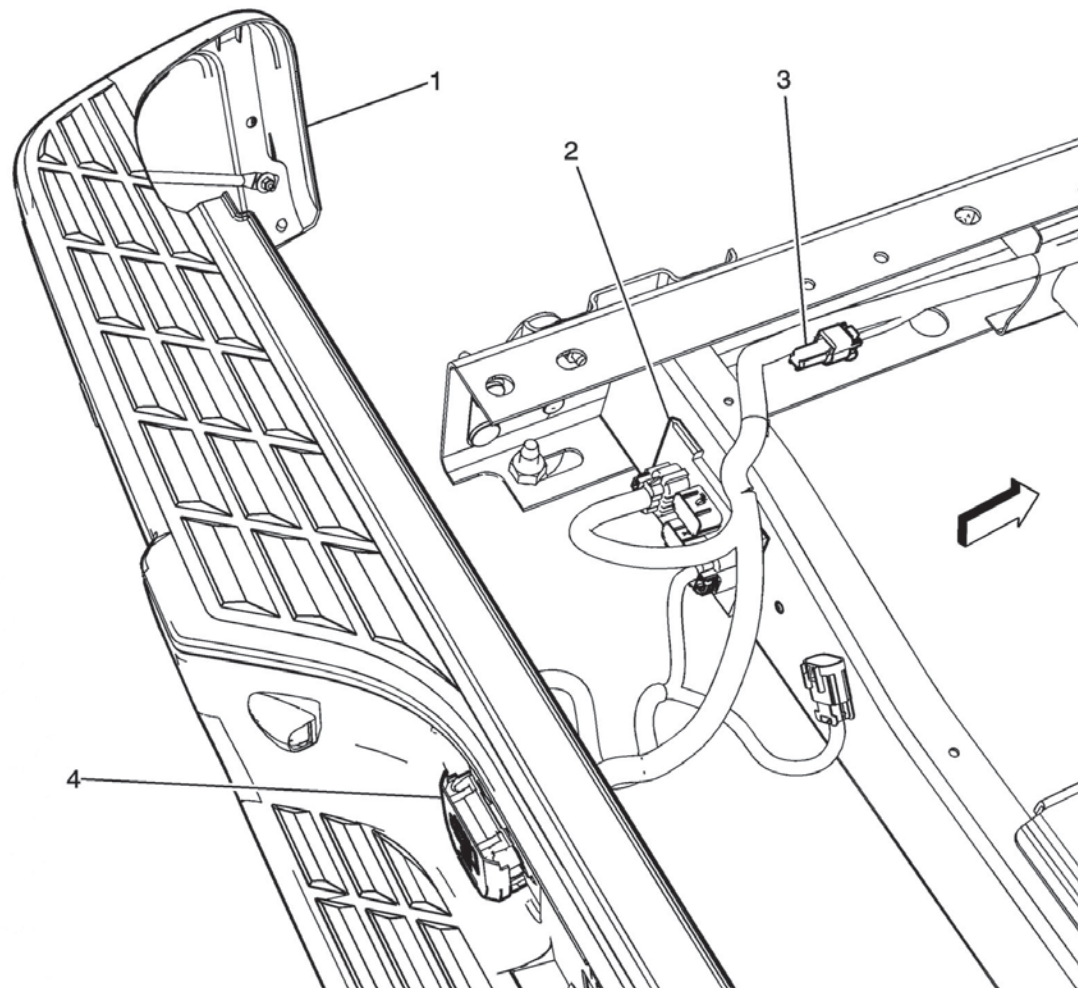

- (1) Rear Bumper
- (2) Junction Block - Rear Lamps
- (3) Terminator Resistor
- (4) **Trailer Connector (UY7)**

Special Applications – Tail Lamp Wiring for Pickup Box Removal

REAR JUNCTION BLOCK

The tail lamp wiring on the All New C/K is routed to a junction block located at the rear of the vehicle. This junction block interfaces with the rear chassis harness and breaks out the license lamp, left turn lamp and right turn lamp connections. A schematic diagram of the Rear Junction Block and tail lamp circuits is shown on pages 3 and 4. On trucks without the Pickup Box Delete (ZW9) option, this junction block is attached to the underside of the box and therefore must be relocated when removing the box. On trucks with ZW9, this junction block is attached to the left frame rail.

The parts required to relocate the Rear Junction Block to left frame are as follows:

- | | |
|-----------------------------|-----------------------|
| – Junction Block | Part Number: 15304995 |
| – Junction Block Bracket | Part Number: 15031996 |
| – Bolt/Screw (two required) | Part Number: 11516885 |

REAR TAIL LAMPS AND LICENSE PLATE LAMP

The parts required to install the rear tail lamps and license plate lamp assembly are as follows:

- | | |
|--------------------------------------|-------------------------------|
| – Tail Lamp Assembly – LH | Service Part Number: 25775557 |
| – Tail lamp Assembly – RH | Service Part Number: 25775558 |
| – Rear License Plate Lamp Assembly | Service Part Number: 15154884 |
| – Stud/plate Assembly (two required) | Service Part Number: 11609856 |
| – Nut (four required) | Service Part Number: 03537772 |

Special Applications – Rear Junction Block / Bracket Installation – Chassis Cab and Box Delete (ZW9) Trucks

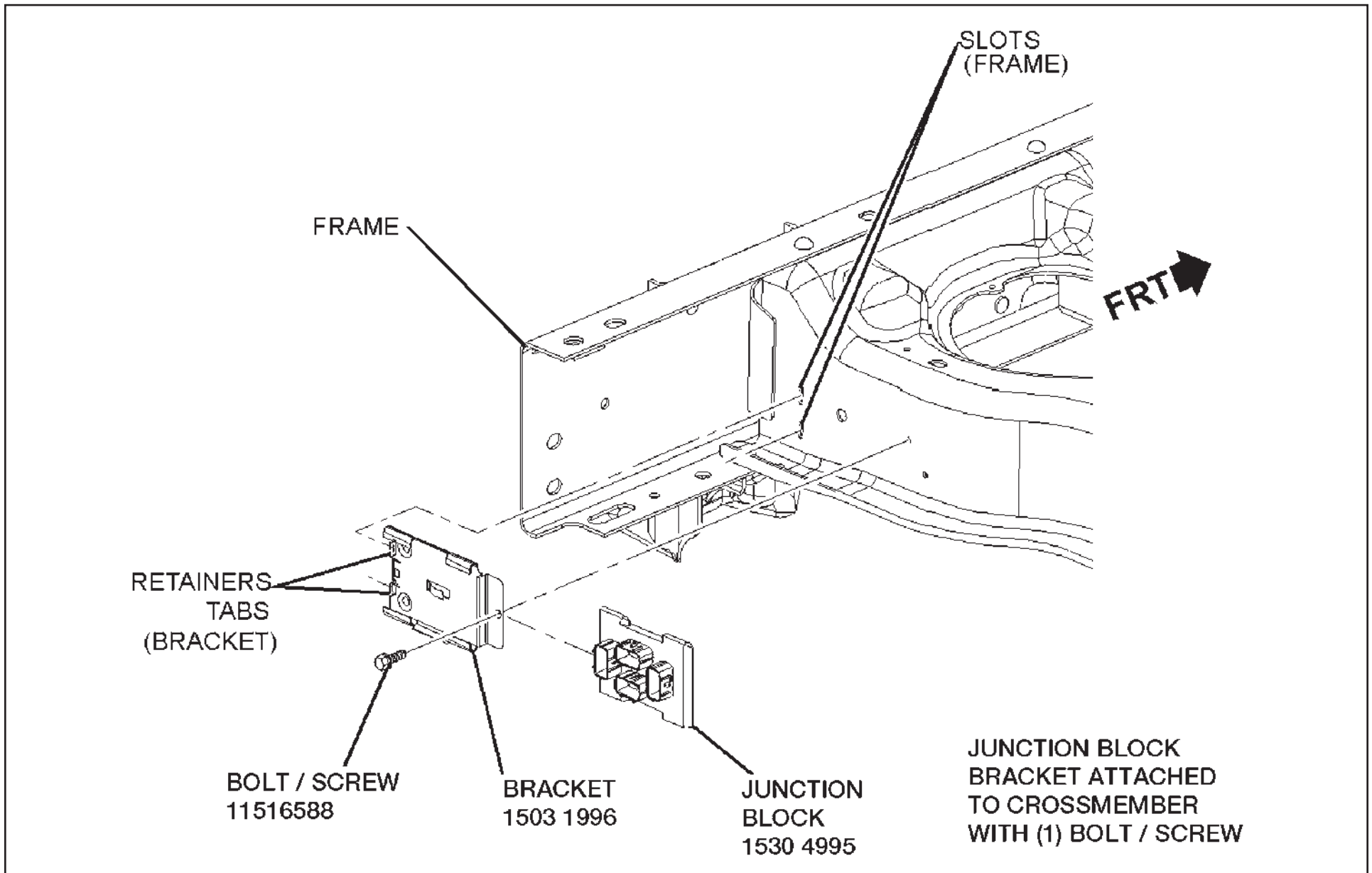

Special Applications – Tail Lamps / Rear Junction Block – Chassis Cab and Box Delete (ZW9) Trucks

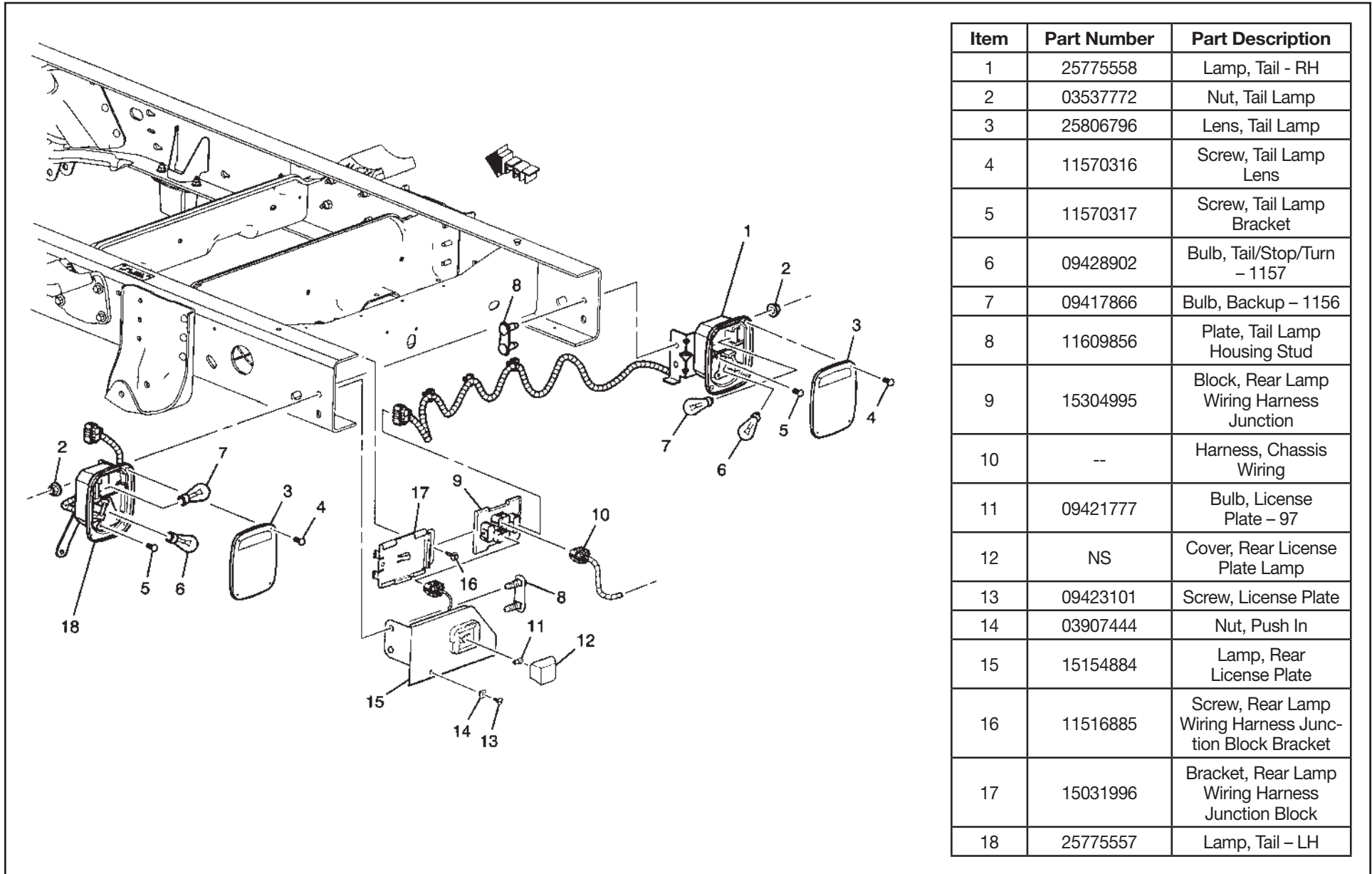

Item	Part Number	Part Description
1	25775558	Lamp, Tail - RH
2	03537772	Nut, Tail Lamp
3	25806796	Lens, Tail Lamp
4	11570316	Screw, Tail Lamp Lens
5	11570317	Screw, Tail Lamp Bracket
6	09428902	Bulb, Tail/Stop/Turn – 1157
7	09417866	Bulb, Backup – 1156
8	11609856	Plate, Tail Lamp Housing Stud
9	15304995	Block, Rear Lamp Wiring Harness Junction
10	--	Harness, Chassis Wiring
11	09421777	Bulb, License Plate – 97
12	NS	Cover, Rear License Plate Lamp
13	09423101	Screw, License Plate
14	03907444	Nut, Push In
15	15154884	Lamp, Rear License Plate
16	11516885	Screw, Rear Lamp Wiring Harness Junction Block Bracket
17	15031996	Bracket, Rear Lamp Wiring Harness Junction Block
18	25775557	Lamp, Tail – LH

Special Applications - Tail Lamps/Rear Junction Block - Chassis Cab and Box Delete (ZW9) Trucks

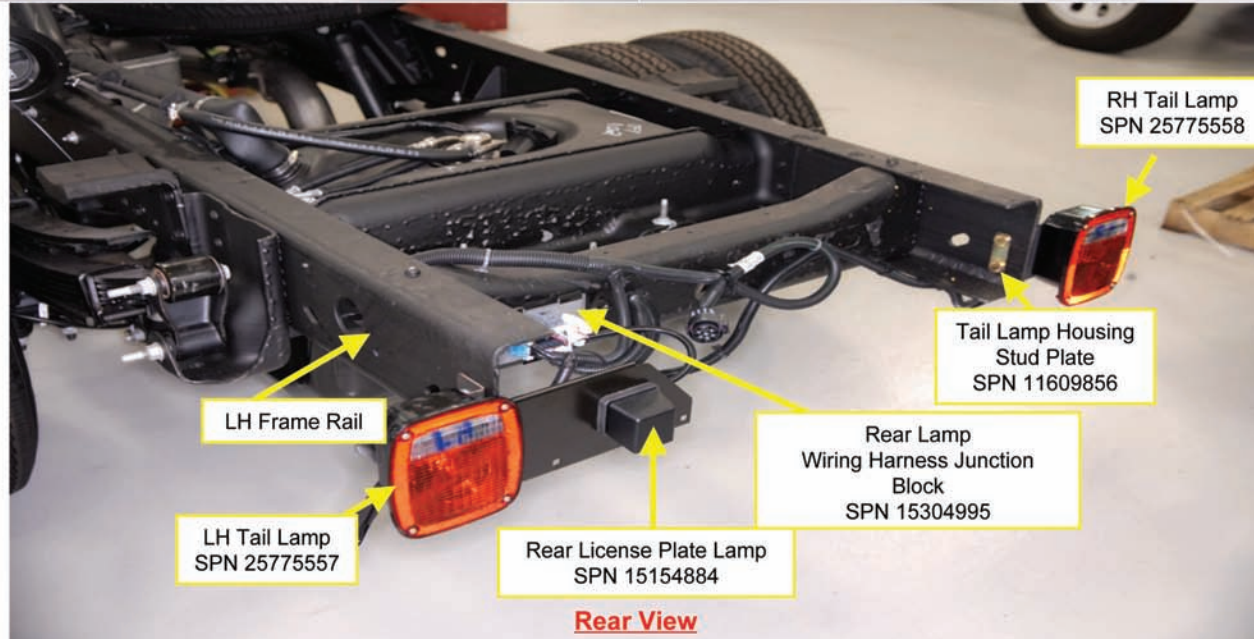
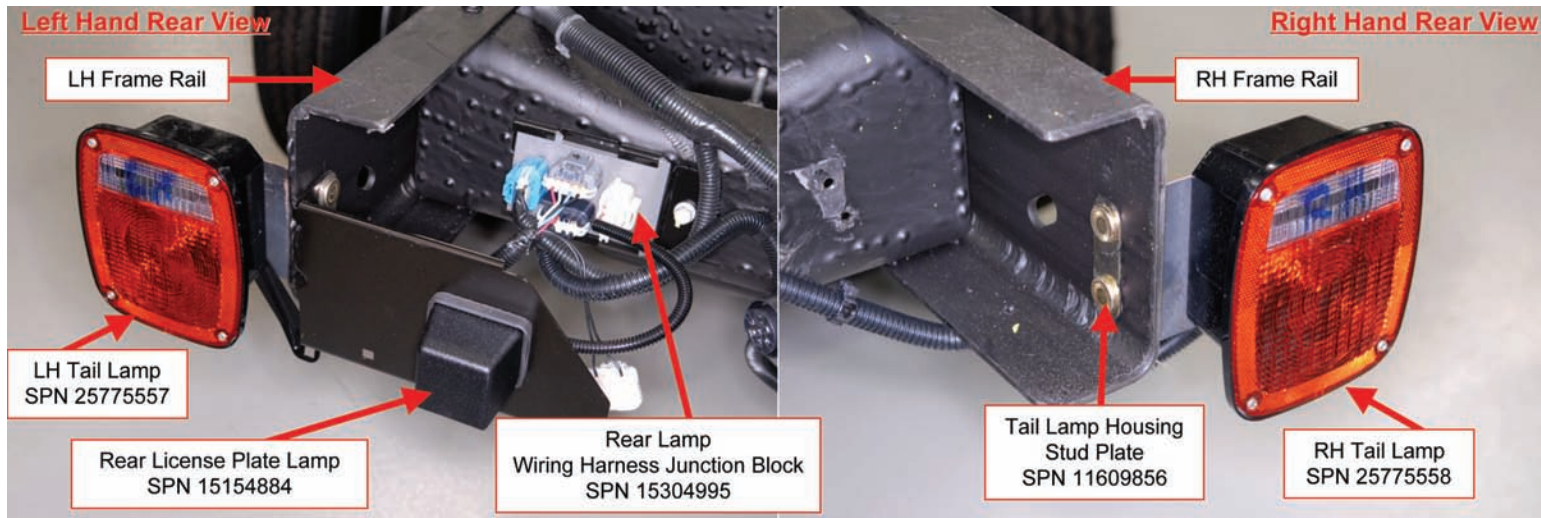

Special Applications - Schematics - Rear Lamps - Chassis Cab and Box Delete (ZW9) Trucks

Rear Stop/Turn Signal Lamps

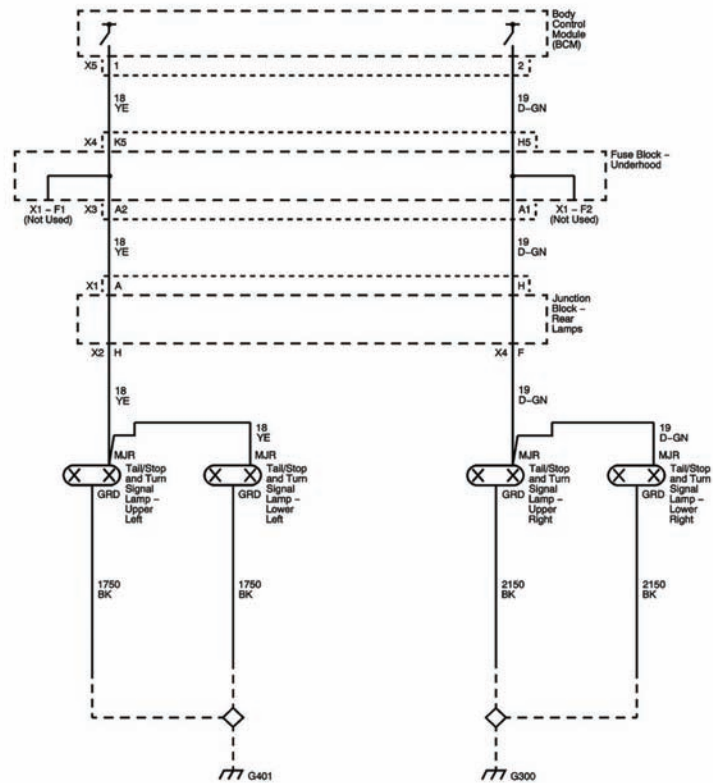

#1914955

Backup Lamps and Backup Alarm

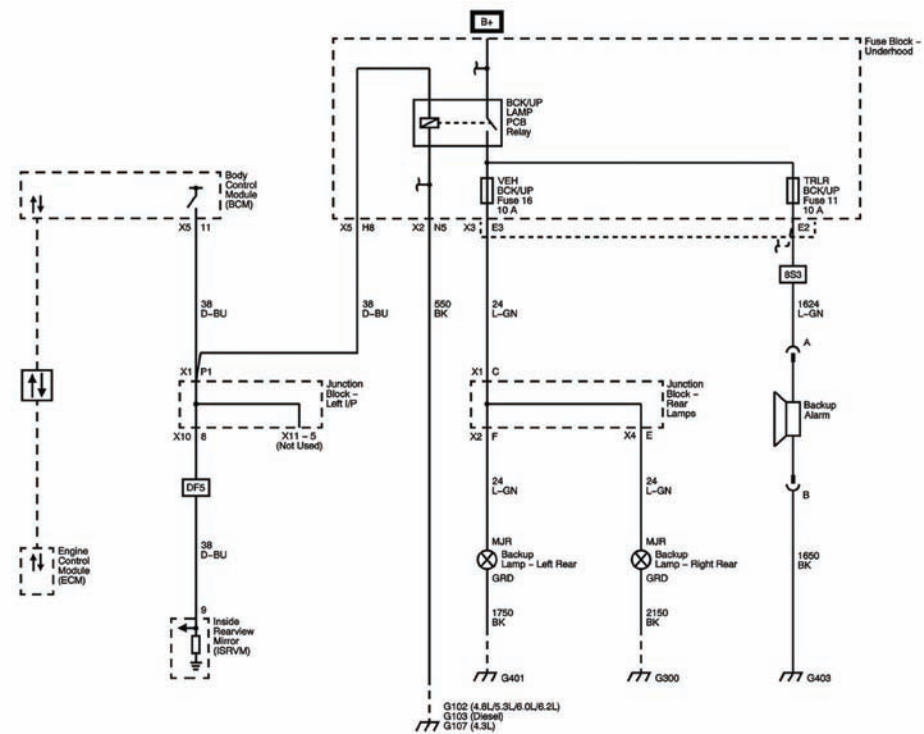

#1914964

Special Applications - Schematics - Rear Lamps - Chassis Cab and Box Delete (ZW9) Trucks

Right Rear Park Lamps

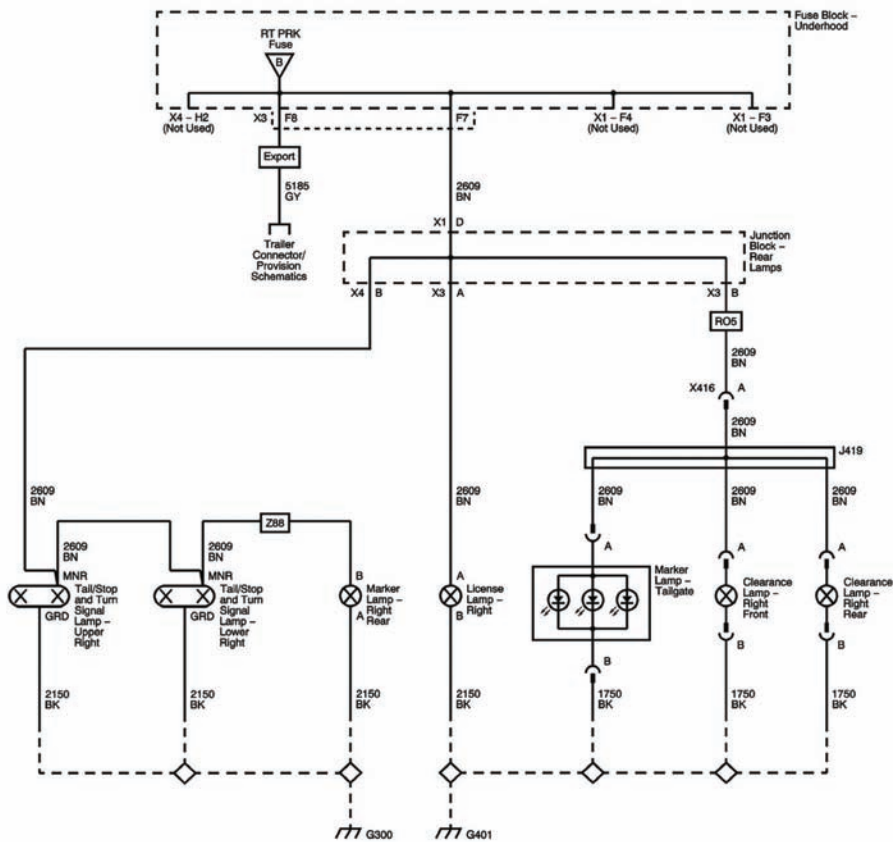

#1914947

Left Rear Park Lamps

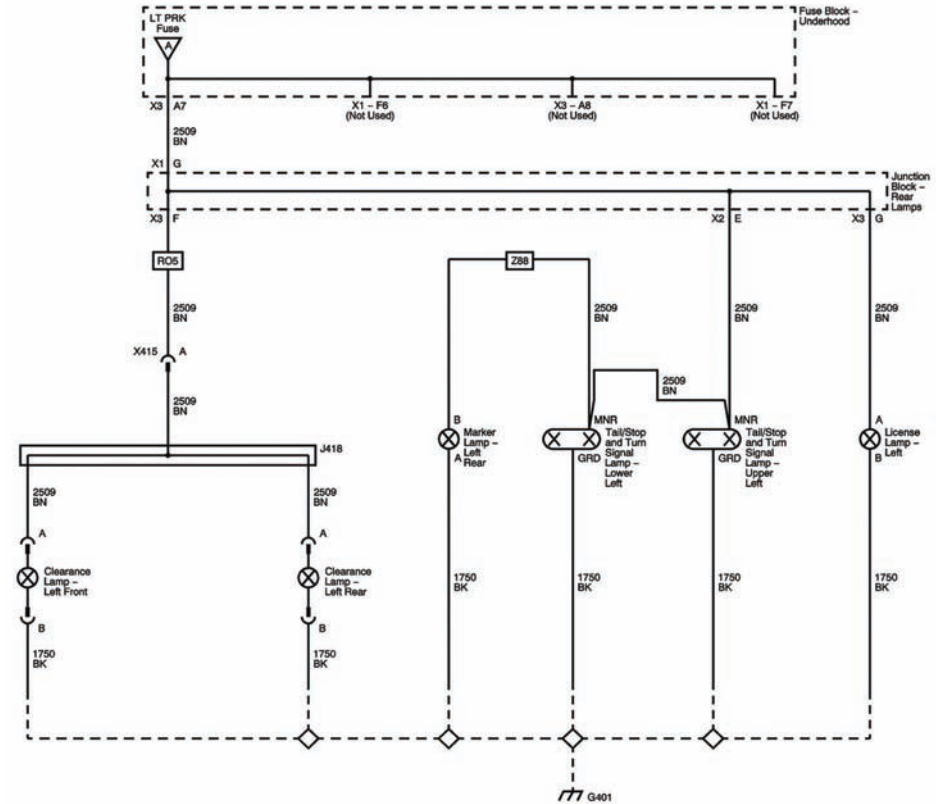

#1914940

Special Applications - Schematics - Trailer - Chassis Cab and Box Delete (ZW9) Trucks

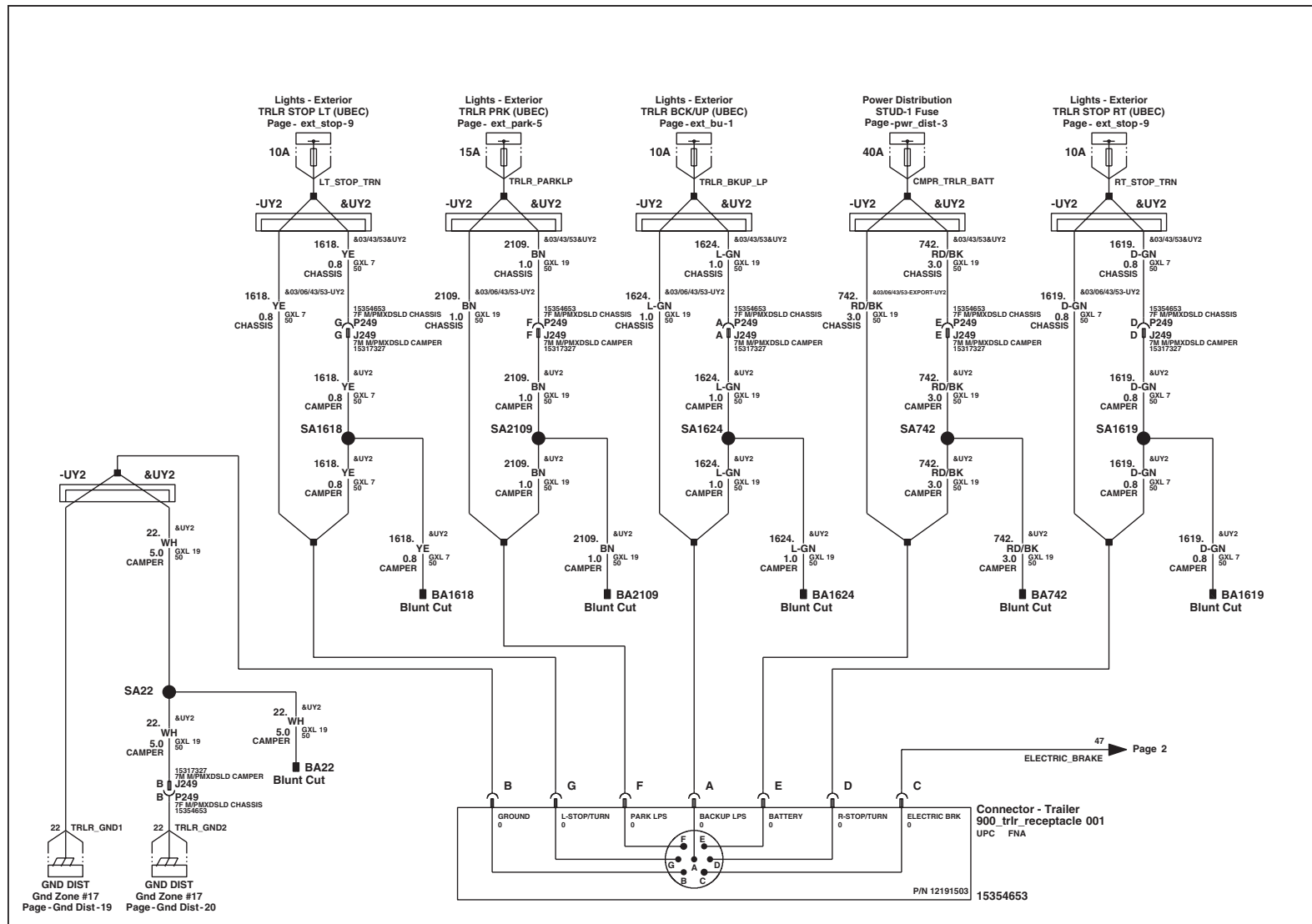

Special Applications – Junction Block Connector X1 – Chassis Cab and Box Delete (ZW9) Trucks

Junction Block - Rear Lamps - X1 Connector Part Information

- OEM: 15317304
- Service: 15306114
- Description: 8-way F GT 280 Sealed (BU)

Terminal Part Information

- | | |
|--|--|
| • Pins: A, C, D, G, H | • Pins: B, E |
| • Terminal/Tray: 15304716/8 | • Terminal/Tray: 15304717/8 |
| • Core/Insulation Crimp: 2/1 | • Core/Insulation Crimp: 4/1 |
| • Release Tool/Test Probe:
15315247/J-35616-4A (PU) | • Release Tool/Test Probe:
15315247/J-35616-4A (PU) |

Junction Block - Rear Lamps, X1			
Pin	Wire Color	Circuit No.	Function
A	0.5 YE	18	Left Rear Stop/Turn Lamp Supply Voltage
B	2 BK	2150	Ground
C	0.8 L-GN	24	Backup Lamp Supply Voltage
D	0.5 BN	2609	Right Rear Park Lamps Supply Voltage
E	2 BK	1750	Ground
F	--	--	Not Used
G	0.8 BN	2509	Left Rear Park Lamp Supply Voltage
H	0.5 D-GN	19	Right Rear Stop/Turn Lamp Supply Voltage

Junction Block-
Rear Lamps

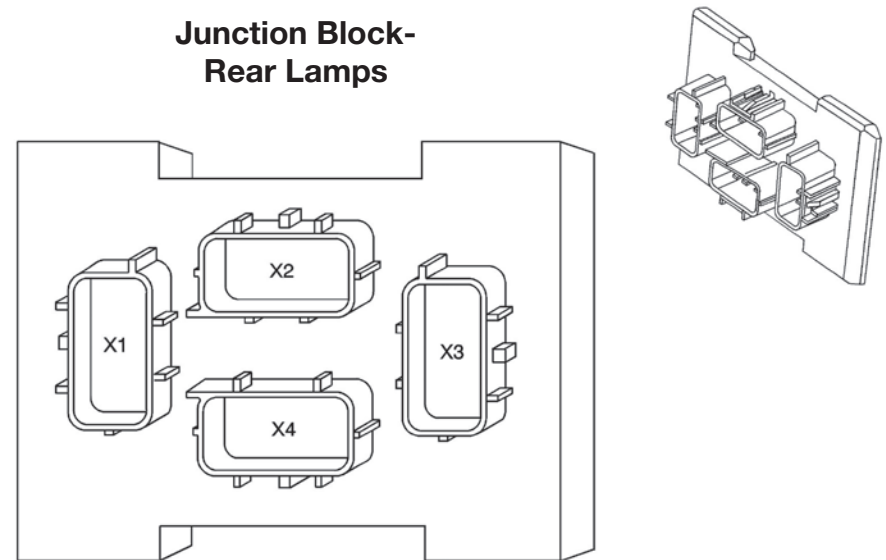

Junction Block-
Rear Lamps X1

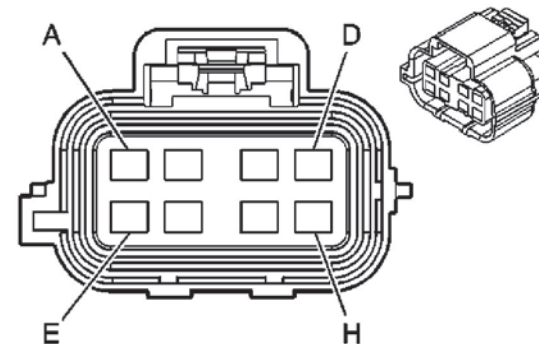

Special Applications – Junction Block Connectors X2 & X3 – Chassis Cab and Box Delete (ZW9) Trucks

Junction Block - Rear Lamps - X2 Connector Part Information

- OEM: 15317305
- Service: 15306338
- Description: 8-way F GT 280 Sealed (GY)

Terminal Part Information

- | | |
|--|--|
| • Pins: A, C, D, G, H | • Pins: B, E |
| • Terminal/Tray: 15304716/8 | • Terminal/Tray: 15304717/8 |
| • Core/Insulation Crimp: 2/1 | • Core/Insulation Crimp: 4/1 |
| • Release Tool/Test Probe:
15315247/J-35616-4A (PU) | • Release Tool/Test Probe:
15315247/J-35616-4A (PU) |

Junction Block - Rear Lamps, X2			
Pin	Wire Color	Circuit No.	Function
A-B	--	--	Not
C	0.8 BK	1750	Ground
D	--	--	Not Used
E	0.8 BN	2509	Left Rear Park Lamps Supply Voltage
F	0.8 L-GN	24	Backup Lamp Supply Voltage
G	--	--	Not Used
G	0.8 BN	2509	Left Rear Park Lamp Supply Voltage
H	0.8 YE	18	Left Rear Stop/Turn Lamp Supply Voltage

Junction Block - Rear Lamps - X3 Connector Part Information

- OEM: 15317308
- Service: 15306135
- Description: 8-way F GT 280 Sealed 5.2 (BN)

Terminal Part Information

- Terminal/Tray: 15304716/8
- Core/Insulation Crimp: E/1
- Release Tool/Test Probe:
15315247/J-35616-4A (PU)

Junction Block - Rear Lamps, X3			
Pin	Wire Color	Circuit No.	Function
A	0.5 BN	2609	Right Rear Park Lamps Supply Voltage
B	0.5 BN	2609	Right Rear Park Lamps Supply Voltage (R05)
C	0.5 BK	1750	Ground (R05)
D	0.5 BK	1750	Ground (R05)
E	0.5 BK	1750	Ground
F	0.5 BN	2509	Left Rear Park Lamps Supply Voltage (R05)
G	0.5 BN	2509	Left Rear Park Lamps Supply Voltage
H	0.5 BK	1750	Ground

Special Applications - Junction Block Connector X4 - Chassis Cab and Box Delete (ZW9) Trucks

Junction Block - Rear Lamps - X4 Connector Part Information

- OEM: 15317306
- Service: 15306339
- Description: 8-way F GT 280 Sealed 5.2 (BK)

Terminal Part Information

- Terminal/Tray: 15304716/8
- Core/Insulation Crimp: E/1
- Release Tool/Test Probe:
15315247/J-35616-4A (PU)

Junction Block - Rear Lamps, X4			
Pin	Wire Color	Circuit No.	Function
A	0.8 BK	2150	Ground
B	0.8 BN	2609	Right Rear Park Lamps Supply Voltage
C-D	--	--	Not Used
E	0.8 L-GN	24	Backup Lamp Supply Voltage
F	0.8 D-GN	19	Right Rear Stop/Turn Lamp Supply Voltage
G-H	--	--	Not Used

Installation of Aftermarket Accessories - Battery, Ignition and Ground Feeds

DO NOT SPLICE INTO WIRING HARNESS



Applicable to GM Models:

2007-2009 Cadillac Escalade, Escalade ESV, Escalade EXT

2007-2009 Chevrolet Avalanche, Silverado, Suburban & Tahoe

2007-2009 GMC Sierra, Sierra Denali, Yukon, Yukon Denali & Yukon XL

There are two different areas on a fullsize truck or utility vehicle where power and grounds can be acquired without having to splice or cut into the existing wiring. One is the MBEC and the other is the UBEC.

MBEC - Mid-Bussed Electrical Connector

The MBEC is located below the instrument panel to the left of the brake pedal (See the graphics - below).

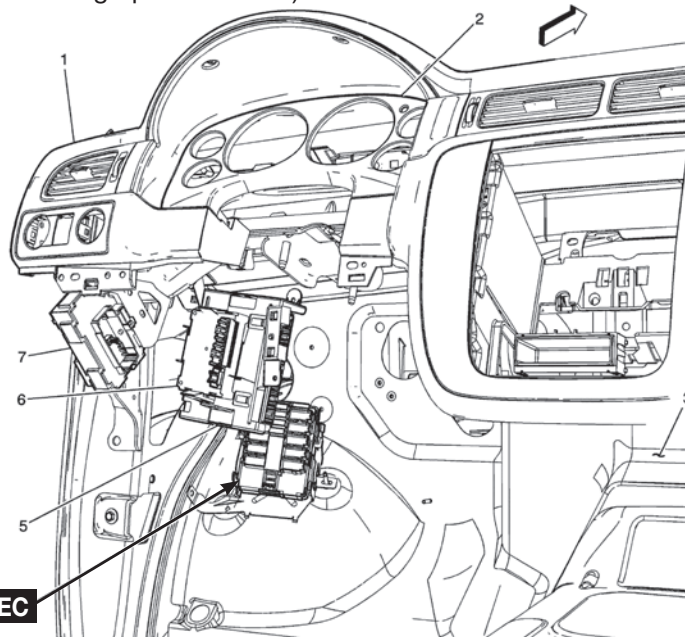

The MBEC has 10 positions for connecting electrical connectors. One of these positions is designated for aftermarket utilization. Install connector (P/N 20791502) into the open position (X14 identified by the arrow in the following graphic).

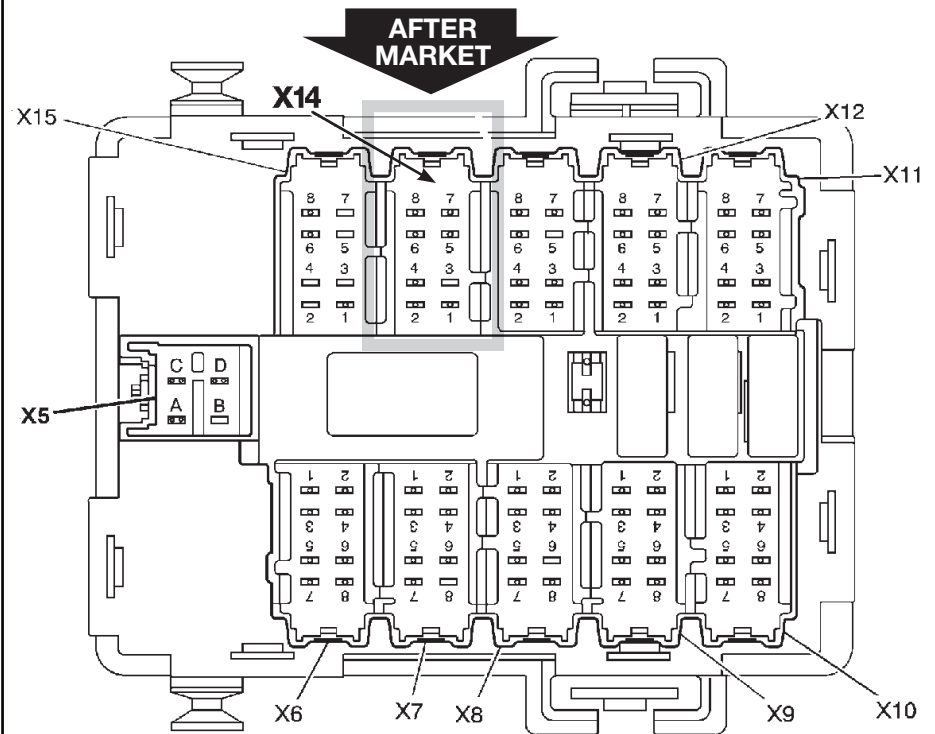

Within this connector, there is a fused 30 Amp battery feed, a fused 15 Amp battery feed, a fused 10 Amp Run/Crank feed, a 300 milliamp RAP (Retained Accessory Power) feed and a ground.

(continued on next page)

From GM Bulletin - Document ID: 2204033 / #08-08-45-004 (Oct. 28, 2008)

Installation of Aftermarket Accessories – Battery, Ignition and Ground Feeds (cont'd)

Important: Connector (P/N 20791502) comes with one wire lead installed. This lead will need to be removed before the connector is pinned for use with aftermarket electrical devices.

The pin out of the connector is as follows:

Cavity	Circuit Description	Circuit Number	Fuse Size
1	Ground	1050	N/A
2	Battery Feed	4540	15 Amps
3	Not Used	--	--
4	Not Used	--	--
5	Battery Feed	2340	30 Amps
6	Not Used	--	--
7	Run/Crank Feed	739	10 Amps
8	RAP Feed	43	300 milliamps

Wire Gauge Selection

For any of these powered connections to be used, Circuit Protection Guidelines must be followed to assure that the circuit gauge is selected appropriately so that it will be protected by the fuse in case of a short circuit.

Information in GM bulletins is intended for use by professional technicians, NOT a "do-it-yourselfer". They are written to inform these technicians of conditions that may occur on some vehicles, or to provide information that could assist in the proper service of a vehicle. Properly trained technicians have the equipment, tools, safety instructions, and know-how to do a job properly and safely. If a condition is described, DO NOT assume that the bulletin applies to your vehicle, or that your vehicle will have that condition. See your GM dealer for information on whether your vehicle may benefit from the information.



UBEC – Underhood Bussed Electrical Connector

On vehicles not equipped with an Auxiliary Battery (Auxiliary Battery RPO TP2), there is a stud that could be used for a fused battery feed at the UBEC. The UBEC is located on the left side of the engine compartment (refer to graphic below).

Connecting Aftermarket Electrical Devices On Vehicles Not Equipped With TP2

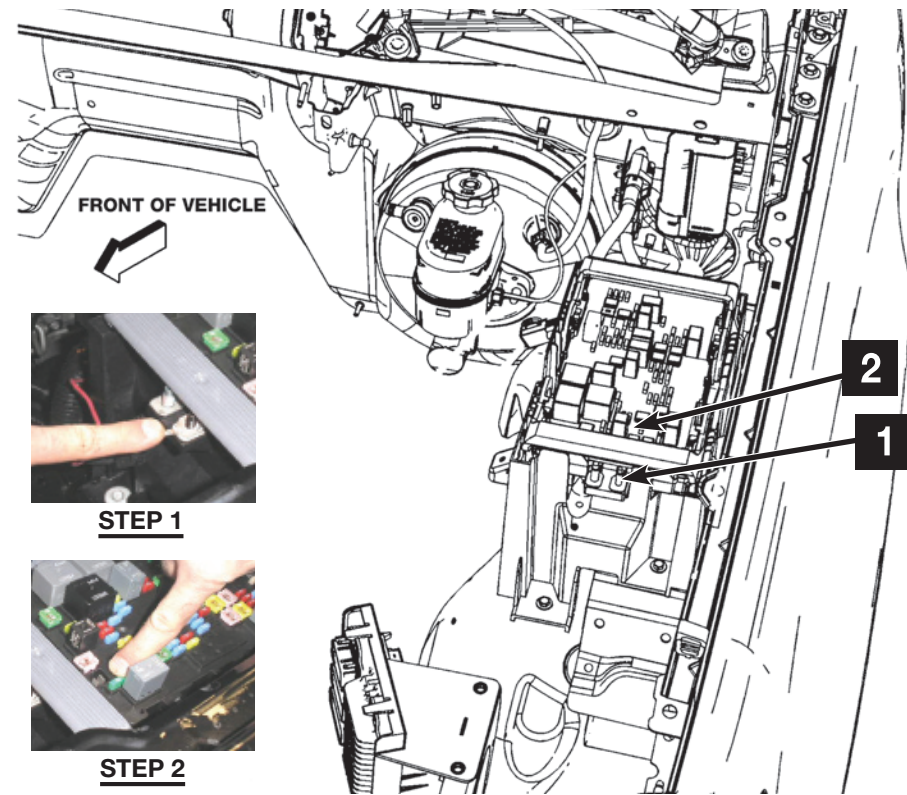

Important:

- (Step 1) The smaller of the two studs (#1 in diagram and photo) provides a fused battery feed. Secure The terminal to stud with an M6 fastener.
- (Step 2) Insert a 40-Amp, J-case fuse (#2 in diagram and photo) to power the circuit.