

Index

SECTION A DESCRIPTION AND OPERATIONS

OVERVIEW

Organization.....	A-1
What's New for 2009 G/H Van.....	A-1
Navigation/Viewing.....	A-2
Printing.....	A-2
Powertrain Options.....	A-3
RPO Code List.....	A-3

BODY CONTROL SYSTEM

Description and Operation.....	A-9
Power Mode Master.....	A-9
Serial Data Gateway.....	A-9
Body Control Module (BCM).....	A-9

DATALINK COMMUNICATIONS – DESCRIPTION AND OPERATION

Circuit Description.....	A-10
GMLAN High Speed Circuit Description.....	A-10
GMLAN Low Speed Circuit Description.....	A-10
Local Interconnect Network (LIN) Description.....	A-11
Data Link Connector (DLC).....	A-11
Serial Data Reference.....	A-11

ELECTRIC POWER MANAGEMENT

Description and Operation.....	A-12
Idle Boost Table.....	A-12

POWER MODE – DESCRIPTION AND OPERATION

Serial Data Power Mode Master.....	A-13
Relay Controlled Power Mode.....	A-14
BCM Awake/Sleep Modes.....	A-14

Index

RETAINED ACCESSORY POWER (RAP) – DESCRIPTION AND OPERATION

Description and Operation	A-15
Relay Controlled RAP	A-15
Serial Data Controlled RAP	A-15

FAST IDLE

Availability	A-16
Bulletin #82	See this document at: http:// www.gmupfitter.com/publicat/bull/63135_FastIdle_UI_82_D3.pdf

GENERATORS

Application Table	A-17
Output Performance	A-17
Installation Drawings	A-18

LIGHTING

Exterior

Description	A-24
Lamps	A-24
Low-Beam Headlight Operation	A-24
High-Beam Headlight Operation	A-24
Flash To Pass (FTP)	A-24
Daytime Running Lamps (DRL) and Automatic Lamp Control (ALC)	A-25
HDLPS Suggested Indicator	A-25
Lights On Warning	A-25
Park, Tail, Marker and License Lamps	A-25
Turn Signal Lamps	A-26
Hazard Lamps	A-26
Stop Lamps	A-26
Backup Lamps	A-27

Index

LIGHTING

Exterior (cont'd)

Rear Fog lamps.....	A-27
Battery Rundown Protection / Inadvertent Power	A-27
Bulb Replacement Procedures.....	A-28
Replacement Bulb List.....	A-30

Interior

Description.....	A-31
Interior Lamps Features.....	A-31
Courtesy Lamps (-YF2/YF7)	A-31

TRAILER WIRING (UY7)

Description.....	A-32
Schematic.....	A-33
Connector End View.....	A-34
Connector Location.....	A-35

AUTOMATIC TRANSMISSION SHIFT LOCK CONTROL

Description and Operation	A-36
Schematic.....	A-37

Index

DIESEL PARTICULATE FILTER (DPF)

DPF System Description	A-38
Diesel Oxidation Catalyst	A-38
Diesel Particulate Filter Layout.....	A-38
Differential Pressure Sensor (DPS) and Pressure Lines.....	A-38
Exhaust Gas Temperature Sensors.....	A-39
Intake Air (IA) Valve.....	A-39
Exhaust Cooler	A-39
Normal Regeneration.....	A-39
Service Regeneration	A-40
Regeneration Process	A-40
Ash Loading.....	A-40
DPF Regeneration Enable	A-41
DPF Service Regeneration	A-42
DPF Service Bulletin.....	A-45
DPF Schematics	
Engine Controls – DPF Exhaust Pressure Differential Sensor (LMM).....	A-46
Engine Controls – Exhaust Temperature Sensor (LMM)	A-47

Index

SECTION B COMPONENTS – LOCATIONS AND PINOUTS

ELECTRONIC MODULES

BODY CONTROL MODULE (BCM)

Location View	B-1
Connector End Views	
X1	B-2
X2	B-3
X3	B-4
X4	B-5
X5	B-6
X6	B-7
X7	B-8
Calibrations	B-9

ENGINE CONTROL MODULE (ECM)

All Engines – Engine Control Module (ECM) – Location	B-10
4.3L (LU3) – Engine Control Module (ECM) – Connector X1	B-11
4.3L (LU3) – Engine Control Module (ECM) – Connector X2	B-13
4.8L (LY2) – 5.3L (LMF) – 6.0L (LY6) – Engine Control Module (ECM) – Connector X1.....	B-15
4.8L (LY2) – 5.3L (LMF) – 6.0L (LY6) – Engine Control Module (ECM) – Connector X2.....	B-17
6.6L (LMM) – Engine Control Module (ECM) – Connector X1	B-19
6.6L (LMM) – Engine Control Module (ECM) – Connector X2	B-22

HVAC CONTROL ASSEMBLY

Location View	B-24
Connector End Views	
X1	B-25
X2	B-26
X3	B-27
X4	B-28

Index

TRANSMISSION CONTROL MODULE (TCM)

Location View.....	B-29
Connector End Views	
Diesel Engine.....	B-30
Gas Engine	B-32

FUSE BLOCKS

UNDERHOOD

Location View.....	B-34
Label.....	B-35
Top View.....	B-39
Bottom View	B-39
X1.....	B-40
X2.....	B-42
X3.....	B-43
X4.....	B-45
X5.....	B-46

BODY

Location View.....	B-47
In-Cab Power Access	B-48
Label.....	B-49
Top View.....	B-52
Bottom View	B-52
X1.....	B-53
X2.....	B-55

Index

REAR (PRP)

Location View.....	B-57
Top View.....	B-58
Bottom View.....	B-59

SWITCHES

A/C LOW PRESSURE SWITCH

Location View.....	B-60
Connector End View	B-61

IGNITION SWITCH

Location View.....	B-62
Connector End View	B-63

PARK BRAKE SWITCH

Location View.....	B-64
Connector End View	B-65

PARK NEUTRAL POSITION (PNP) SWITCH

Location View.....	B-66
Connector End View	B-67

STOP LAMP SWITCH

Location View.....	Refer to page B-64
Connector End View	B-68

ENGINE COOLANT LEVEL SWITCH (DIESEL)

Location View.....	B-69
Connector End View	B-70

Index

MISCELLANEOUS ELECTRICAL COMPONENTS

BACK-UP ALARM

Location View.....	B-71
Connector End View	B-72

DOMELAMP (CARGO)

Location View.....	B-73
Connector End View	B-74

AUTOMATIC TRANSMISSION SHIFT LOCK CONTROL SOLENOID

Location View.....	B-75
Connector End View	B-76

AUTOMATIC TRANSMISSION SHAFT SPEED SENSOR (OSS)

Location View.....	B-77
Connector End View	B-78

COMPONENT AND CONNECTOR LOCATIONS AND PINOUTS

Location View.....	B-79
--------------------	------

Index

SECTION C CONNECTORS – LOCATIONS AND PINOUTS

DATA LINK CONNECTOR

Location View	C-1
Connector End View	C-2

IN-LINE HARNESS CONNECTOR END VIEWS

Location Views.....	C-3 to C-9
X200 – Steering Column Harness to I/P Harness.....	C-10
X205 – Front Headliner Harness to Body Harness.....	C-14
X222 – (YF2/YF7) Upfitter Provision Harness to I/P Harness.....	C-16
X318 – (Passenger/Cargo) I/P Harness to Body Harness	C-17
X319 – (C36/ENC) Rear Heater Switch Harness to Body Harness.....	C-21
X320 – (YF2/YF7) Body Harness to Upfitter Connector	C-22
X321 – (YF2/YF7) Upfitter Harness to Body Harness.....	C-23
X400 – (Passenger/Cargo) Right Rear Cargo Door to Body Harness	C-24
X401 – (Passenger/Cargo) Left Tail Lamp Harness to Body Harness.....	C-25
X402 – (Passenger/Cargo) Right Tail Lamp Harness to Body Harness.....	C-26
X405 – (Cutaway) Rear Lighting Connector to Chassis Harness	C-27
X411 – (Passenger/Cargo) Left Rear Cargo Door to Body Harness.....	C-28
X412 – (Passenger/Cargo) Right Rear Cargo Door to Body Harness	C-29
X415 – (Passenger/Cargo) Right Rear Speaker Harness to Body Harness	C-30
X417 – (Cargo w/o YF7) Dome Lamp Harness to Body Harness	C-31

GENERATOR CONNECTORS

Location View	C-32
Connector End View	
X1	C-33
X2	C-34
Auxiliary X1 – (KD9 + YF2).....	C-35
Auxiliary X2 – (KD9 + YF2).....	C-36

Index

SECTION E FREQUENTLY ASKED QUESTIONS

In-Cab Power	(See page B-48)	E-1
Rear HVAC Control.....		E-1
Backup Alarm		E-1
Fast Idle.....	(See Bulletin #82 at: http://www.gmupfitter.com/publicat/bull/63135_FastIdle_UI_82_D3.pdf)	E-1
Starter Interrupt		E-1
Park/Neutral.....	(See page B-75 and B-76)	E-1
I/P Panel Illumination for Auxiliary Switches.....	(See Option 1: at Connector X205 on pages C-8 and C-14 ; or See Option 2: at BCM on pages B-1 and B-3)	E-1
Access to Park and Clearance Lamp Circuit.....	(See Option 1: at Connector X405 on pages C-9 and C-27 ; or See Option 2: on Body Fuse Block (BBEC), Connector X1 on pages B-47 and B-53)	E-1
Horn Control.....	(See Fuse #43 Horn Control in Underhood Fuse Block (UHBEC) on pages B-35 and B-37 ; or See Horn Control at UHBEC, Connector X1, Pin 53, Circuit #29 on page B-41)	E-1
Park Brake Signal.....	(See pages B-64 and B-65)	E-1
Starter Crank Signal	(See pages B-35 and B-41)	E-1
Door Lock Signals	(See Fuse #27 - Front Door Lock on pages B-50 and B-53 ; also pages B-55 and B-56 ; See Fuse #31 - Driver Door Unlock on pages B-50 and B-53 ; also pages B-55 and B-56)	E-1

Section A – Description and Operation **Overview**

ORGANIZATION

The 2009 G/H Van Electrical Body Builder Manual is organized as follows:

- A. System Operation – Description of how things function
- B. Components (including Electronic Modules) – Location and Pinouts
- C. Connectors – Location and Pinouts
- D. Subsystem Schematics – Detailed wiring and electrical schematic information
- E. Upfitter’s Quick Reference – Additional information on existing and new features, as well as Frequently Asked Questions

WHAT’S NEW FOR THE 2009 G/H VAN

Major changes for 2009 include:

- **Separate Stop/Turn Lamps**
A new BCM calibration is now standard on Cutaways that provides separation of the stop and turn signal circuits on vehicles equipped with the School Bus Package (B3D) or Ambulance Package (YF2). BCM calibration is optional for other Cutaways (RPO V4D).
- **Back-Up Alarm – SEO 8S3**
Back-Up Alarm (SEO 8S3) is now available on:
33405 vehicles (3500 Cargo with 135 in w/b) with the 4.8L (LY2) and 6.0L (LY6) gas engines
23705 & 33705 vehicles (2500/3500 Cargo w/155 in w/b) and 33503, 33803, & 33903 vehicles (3500 Cutaway w/139, 159, & 177 in w/b)
- **Trailer Wiring on Cutaways – RPO UY7**
On 33803 vehicles (3500 Cutaway with 159 in w/b), Trailer Wiring (UY7) is now available with the 6.0L (LY6) gas engine, in addition to the 6.6L (LMM) diesel.
- **70 mph Governor on Gas Engine Models – SEO 9B9**
A 70 mph governor option is now available on 2500/3500 Cargo & Cutaway models with the 4.8L (LY2) and 6.0L (LY6) gas engines
- **LED Lamp Flasher Calibration**
On all Cutaways, LED Lamp calibration has been made part of base content.
A Service calibration has also been made available. There is also an Incandescent Lamp calibration available (SEO 8H8).

Description and Operation – Overview (cont'd)

WHAT'S NEW FOR THE 2009 G/H VAN (continued)

- **Fast Idle on 6.0L (LY6) Gas Engine**
Fast Idle is now available with the 6.0L (LY6) gas engine, in addition to the 6.6L (LMM) diesel. Cruise Control (K34) is still required when ordering Fast Idle (UF3) with either engine.
- **Use of Biodiesel (B20) on Diesels – SEO 5F4**
The use of Biodiesel (B20) diesel fuel is allowed on specific fleet vehicles equipped with 6.6L (LMM) diesel. Available ONLY with 33 gal midship mounted fuel tank and without Fuel Fired Heater (RPO K08).
- **HD Commercial Cutaway GVWR Increase (increase from 14,050 to 14,200)**
HD Commercial Cutaway GVWR's released at 14,200 lbs. (RPO-C7I) and 13,980 lbs. (RPO-C8V) based on emission classifications. Diesel applications at 14,200 lbs. GVWR will have the 57 gallon rear tank (RPO NE7) standard to accommodate the additional diesel engine package weight with the required front GAWR. Specific diesel applications at 14,200 lbs. GVWR requiring a 33 gallon side mount tank can be considered through the SEO process. Both the 33 gallon and 57 gallon fuel tanks will be available with the 14,200 lb. GVWR gas engine applications. The Front Gross Axle Weight Rating (GAWR) remains unchanged at 4600 lbs. and the rear GAWR is increased from 9450 lbs. to 9600 lbs.

NAVIGATION / VIEWING

The Index items are linked to the actual page. Click on the item of interest and you'll go to the corresponding page. The tab at the top of the page has other options available. From left to right:

- Print
- Save
- Previous page
- Next Page
- Page Number (in box)
- Zoom – Decrease Magnification
- Zoom – Increase Magnification
- Zoom – Percentage Option (with drop down menu)
- Scroll Through Pages
- Step Through Pages (one at a time)
- Find (with drop down menu)

PRINTING

Specific pages can be printed out. Be careful to select a print range or "current page" otherwise all 326 pages will be printed out. The information provided in this document is believed to be accurate at time of publication. General Motors reserves the right to change the information contained in this document at any time.

(continued on next page)

Overview (cont'd)

Engines	LMM	6.6L V8 Duramax® – Diesel
	LU3	4.3L V6 GMPT – Gas
	LY2	4.8L V8 GMPT – Gas
	LY6	6.0L V8 GMPT – Gas
Transmissions Duty	MN8	Automatic – 4 Speed – HMD 4L80E – Heavy
	MT1	Automatic – 4 Speed – HMD 4L80E
	M30	Automatic – 4 Speed – HMD 4L60E
Axles	GT4	Rear – 3.73 Ratio
	GT5	Rear – 4.10 Ratio
	GU6	Rear – 3.42 Ratio

Engine/Transmission Combinations

Passenger	5.3L (LMF) + 4L60E (M30)
	6.0L (LY6) + 4L80E (MT1)

Engine/Transmission Combinations (cont'd)

Cargo	4.3L (LU3) + 4L60E (M30)
	4.8L (LY2) + 4L80E (MT1)
	5.3L (LMF) + 4L60E (M30)
	6.0L (LY6) + 4L80E (MT1)
	6.6L (LMM) + 4L80E-HD (MN8)
Cargo – YF7 Upfitter	5.3L (LMF) + 4L60E (M30)
	6.0L (LY6) + 4L80E (MT1)
Cargo – Mobility/Transit	6.0L (LY6) + 4L80E (MT1)
Cutaway	4.8L (LY2) + 4L80E (MT1)
	6.0L (LY6) + 4L80E (MT1)
	6.6L (LMM) + 4L80E-HD (MN8)

RPO CODE LIST

The production/process codes provide the description of the Regular Production Options (RPO's). The RPO list is printed on the Service Parts Identification Label.

RPO	Description
ASF	Restraint – Roof Side, Left and Right, Inflatable
AXP	VIN Identification – Position, Multi-Purpose Vehicle
AXQ	VIN Identification – Position, Bus
AG1	Adjuster Front Seat – Power, Multi-Directional, Driver
AG2	Adjuster Passenger Seat – Power, Multi-Directional
AJ1	Window Tinted – Deep, All Except Windshield and Doors
AJ3	Restraint System – Seat Inflatable, Driver
AK5	Restraint System – Seat Inflatable, Driver and Passenger
AL0	Sensor Indicator – Inflatable Restraint, Front Passenger/Child Presence Detector
AR7	Seat – Front Bucket, Standard
AS5	Seat – Front Bucket, Deluxe

RPO	Description
AU0	Lock Control, Entry – Remote Entry
AU3	Lock Control – Side Door, Electric
AO7	Window – Body
AO8	Windows – Body Right Side
A12	Window Rear – Door STA
A13	Window Side Door – Rear STA
A17	Window Side Body – Swing Out, Left
A18	Window Rear – Door, Swing Out
A19	Window Side Door – Rear, Swing Out
A31	Window – Power Operated, All Doors
BAG	Parts Package – Export
BNC	Parts Package – Body Mount Cushions

Overview (cont'd)

RPO CODE LIST (cont'd)

RPO	Description
BA0	Ornamentation – Exterior, Door, Nameplate
BA3	Compartment – Stowage, I/P Lower Extension Deluxe
BG5	Covering Floor – Delete
B3D	Equipment – School Bus
B30	Covering Floor – Carpet
B31	Covering Floor – Vinyl, Front, Full Width
B32	Covering Front – Floor Mats, Auxiliary
B33	Covering Rear – Floor Mats, Auxiliary
B38	Covering Floor – Vinyl, Front and Rear, Full Width
B4L	Label – Price Refer Geographic Chart
B46	Trim Equipment – Special Order
CU7	Country – Kuwait
CU8	Country – Saudi Arabia
CV3	Country – Mexico
CV4	Country – Israel
CW2	Country – Gulf Areas (Bahrain, Kuwait, Oman, Qatar, Saudi Arabia, UAE)
CW3	Country – Asia/Pacific (Bangladesh, Fiji, Laos)
CW5	Country – Venezuela
CW6	Country – Guam
CW9	Country – Miscellaneous
C36	Heater – Auxiliary
C42	HVAC System – Heater, Outside Air, Deluxe
C49	Defogger – Rear Window, Electric
C5Z	GVW Rating – 7,200 lbs

RPO	Description
C6P	GVW Rating – 8,600 lbs/3900 kg
C6Y	GVW Rating – 9,600 lbs
C60	HVAC System – Air Conditioner Front, Manual Controls
C69	HVAC System Rear – Air Conditioner
C7A	GVW Rating – 10,000 lbs
C7F	GVW Rating – 14,050 lbs
C7N	GVW Rating – 12,300 lbs
C99	Switch – Inflatable Restraint, I/P Module Manual Suppression
DE2	Mirror Outside – Left and Right, Manual Control, Folding, Color
DE5	Mirror Outside – Left and Right, Remote Control, Electric Heated, Folding, Color
DE7	Mirror Outside – Left and Right, Remote Control, Electric, Heated, Light Sensitive, Manual Folding, Turn Signal Indicator, Color
DF2	Mirror Outside – Left and Right, Wide Load Folding, Stainless Steel
DHC	Mirror Outside – Left and Right, Manual Control, AUX WFOV, Color
DH6	Mirror Inside Front Vanity – Left and Right, Sunshade, Illumination
DT4	Ashtray – Cigarette Lighter
D28	Mirror Outside – Delete
D31	Mirror Inside Rearview – Tilt
ENC	HVAC Provisions – Auxiliary Heater Plumbing and Wiring

Overview (cont'd)

RPO CODE LIST (cont'd)

RPO	Description
EVA	Test – DVT, EVAP Emission Requirement
EXP	Export
E24	Door Side – Rear, Hinged
E26	Door Side Rear Left – Hinged
E3T	Handle – Inside, Door Release
FE9	Certification – Emission Federal
GT4	Axle Rear – 3.73 Ratio
GT5	Axle Rear – 4.10 Ratio
GU6	Axle Rear – 3.42 Ratio
G80	Axle Positraction – Limited Slip
JH5	Brake – Hydraulic Power, 4-Wheel Disc, 7,300 lbs
JH6	Brake – Hydraulic Power, 4-Wheel Disc, 9,900 lbs
JH7	Brake – Hydraulic Power, 4-Wheel Disc, 12,300 lbs
JL4	Control – Active Brake
KUP	Throttle Control – Electronic
KC4	Cooling System – Engine Oil
KD1	Cooling System – Transmission Oil
KD9	Generator – 145 Amp, Dual
KG3	Generator – 145 Amp
K05	Heater Engine – Block
K08	Heater – Auxiliary, Fuel Fired
K34	Cruise Control – Automatic, Electronic
K50	Fuel – Fitting, Line Take-Off
K68	Generator –105 Amp

RPO	Description
LMF	Engine –Flexible Fuel, (Gas/ALC) 8 Cylinder, 5.3L, SFI, V8, OHV, Iron, GM
LMM	Engine – Diesel, 8 Cylinder, 6.6L, DPI, V8, Duramax®
LU3	Engine – Gas, 6 Cylinder, 4.3L, MFI, V6, 90 Degree
LY2	Engine – Gas, 8 Cylinder, 4.8L, SFI, Iron, GM
LY6	Engine – Gas, 8 Cylinder, 6.0L, SFI, Iron, GM
MTF	Provisions – Fire Extinguisher Mounting
MN8	Transmission – Auto 4 Speed, HMD, 4L80-E, Heavy Duty
MT1	Transmission – Auto 4 Speed, HMD, 4L80-E
M30	Transmission – Auto 4 Speed, 4L60-E, Electronic
NCF	Lock – Child Security Feature – Delete
NA1	Emission System GVW – Less Than 8,500 lbs
NA4	Emission System GVW– Above 8,500 lbs
NB8	Emission Override – California System
NC7	Emission Override – Federal System
NC8	Emission System California ULEV (Note: Not to be used after 2007 model year for domestic NAO passenger car and light duty trucks.)
NE1	Certification – Emission, Geographically Restricted Registration for Vehicles Up to 14,000 lbs GVW (Use 2003 MDL YR)
NE7	Fuel Tank – 227 L, 57 Gal
NF4	Emission System – Clean Fuel Fleet
NF9	Emission System – General, OBD MIL Suppression
NP5	Steering Wheel – Leather Wrapped
NT7	Emission System – Federal, Tier 2

Overview (cont'd)

RPO CODE LIST (cont'd)

RPO	Description
NT8	Emission System – Federal, Tier 2 A
NT9	Emission System – Federal, Tier 2 Phase-Out
NU1	Emission System – California Level 2
NU4	Emission System – California Level 2 Plus
N12	Exhaust System – Rear Exit
N15	Flexible Fuel – Ethanol
N33	Steering Column – Tilt Type
PNC	Panel – Trim, Front Doors and Side Rear Door(s) and Rear Doors
PPC	Panel – Trim, Rear Doors
PRP	Sales Package – Commercial Tradesman
PF4	Wheel – 16 x 7, Aluminum
PF9	Wheel – 16 x 7, Aluminum Cast
PY2	Wheel – 16 x 6.5, Chrome Appearance
P03	Cover, Wheel – VAR 3
R04	Wheel Configuration – Rear, Single
R05	Wheel Configuration – Rear, Dual
R25	Appearance Package – Exterior, Chrome Grille and Painted Bumper
R26	Appearance Package – Exterior, Chrome Grille and Front Bumper
R4W	Tire Brand All – Michelin
TGA	Language Control – English, French, Spanish
TGG	Language Control – English, Arabic, French
TR9	Lamp Group
T62	Lamp System – Daytime Running – Delete

RPO	Description
T79	Lamp – Fog, Rear
UFA	Display – Outside Temperature
UXZ	Radio – Provisions For
UA1	Battery – High Capacity, Wet
UC2	Speedometer – Instrument, Kilometer and Miles, Kilometer Odometer, Positive Bias
UD4	Alarm – Vehicle Speed, 120 km/hr
UF2	Lamp – Cargo
UF3	High Idle
UJ1	Indicator – System, Brake Warning
UJ6	Indicator – Low Tire Pressure
UL5	Radio – Delete
UL8	Frequencies – Saudi Arabian
US8	Radio – AM/FM Stereo, Seek/Scan, CD, Auto Tone, Clock, ETR, MP3, RDS
US9	Radio – AM/FM Stereo, Seek/Scan, RDS, Multiple Compact Disc, Auto Tone Control, Clock, ETR, MP3
UY7	Wiring Harness – Truck Trailer, HD
U05	Horn – Dual
U1C	Radio – AM/FM Stereo, Seek/Scan, CD, Clock, ETR
U19	Speedometer – Instrument, Kilometer and Miles, Kilometer Odometer
U73	Antenna – Fixed, Radio
U74	Antenna – Radio – Delete
U80	Display – Compass
VBX	Language Label – Arabic

Overview (cont'd)

RPO CODE LIST (cont'd)

RPO	Description
VJG	Bumper Rear – Black
VPH	Vehicle Preparation – Overseas Delivery
VXS	Vehicle – Complete
VXT	Vehicle – Incomplete
VC0	Vehicle – Label, Noise Control Information
VC5	Label – Shipping, Except US, US Possessions, or Japan
VC7	Label – Price/Fuel Economy, Guam
VG8	Vehicle – Label, Notice to Buyer
VH6	Bumper Front – Black
VH9	Envelope – Owner Information Manual
VK3	License Plate Front – Front Mounting Package
VK5	Seat – Temporary, for Shipping
VP6	Noise Control
VR4	Trailer Hitch – Weight Distributing Platform
VR6	Hook – Tie-Down Shipping
VT7	Owners Manual – English Language
V10	Provision Options – Cold Weather
V14	Cooler – Oil, Transmission, Auxiliary
V22	Grille – Radiator, Chrome
V37	Bumper – Front and Rear, Chrome
V46	Bumper Front – Chrome
V60	Vehicle Statement – Gulf States Organization, Incomplete Vehicle
V73	Vehicle Statement – USA/Canada
V78	Vehicle Statement – Delete

RPO	Description
V87	Vehicle Statement – Gulf States Organization
WEN	Plant Code – Wentzville, MO, USA
W1Y	Control – Steering Wheel, Radio, Redundant Controls
XHF	Tire Front – LT225/75R16E BL R/PE ST ALS
XHH	Tire Front – LT245/75R16E BW R/PE ST TL ALS 120Q
XHP	Tire Front – LT225/75R16D BL R/PE ST TL ALS
XLP	Tire Front – LT245/75R16E BW R/PE ST TL ALS 120/116S
XNK	Tire Front – P245/75R16-109S BW R/PE ST TL ALS
XNL	Tire Front – P245/75R16-109S WOL R/PE ST TL ALS
X88	Market Brand – Chevrolet
YHF	Tire Rear – LT225/75R16/E BL R/PE ST ALS
YHH	Tire Rear – LT245/75R16/E BW R/PE ST TL ALS 120Q
YHP	Tire Rear – LT225/75R16/D BL R/PE ST TL ALS
YLP	Tire Rear – LT245/75R16/E BW R/PE ST TL ALS 120/116S
YNK	Tire Rear – P245/75R16-109S BW R/PE ST TL ALS
YNL	Tire Rear – P245/75R16-109S WOL R/PE ST TL ALS
YA2	Door Side – Rear, Sliding
YB9	Paint Process – Interior – Delete
YC6	Convenience Package – Decor Level #6
YF1	Sales Package – Cutaway Upfitter
YF2	Sales Package – Ambulance Upfitter
YF5	Certification – Emission, California
YF7	Sales Package – Recreational Vehicle, Upfitter

Overview (cont'd)

RPO CODE LIST (cont'd)

RPO	Description
Y3G	Merchandised Package – Handicapped, Mobility, Personal Use
Y3H	Merchandised Package – Handicapped, Mobility, Paratransit
ZHF	Tire Spare – LT225/75R16/E BL R/PE ST ALS
ZHH	Tire Spare – LT245/75R16/E BW R/PE ST TL ALS 120Q
ZHP	Tire Spare – LT225/75R16D BL R/PE ST TL ALS
ZLP	Tire Spare – LT245/75R16/EE BW R/PE ST TL ALS 120/116S
ZNK	Tire Spare – P245/75R16-109S BW R/PE ST TL ALS
ZNL	Tire Spare – P245/75R16-109S WOL R/PE T TL ALS
ZP0	Seating Arrangement – Temporary Driver
ZP3	Seating Arrangement – 15 Passenger
ZP8	Seating Arrangement – 8 Passenger
ZQ2	Sales Package – Driver Convenience
ZQ3	Sales Package – Driver Convenience II

RPO	Description
ZR7	Appearance Package – Grille and Bumper Chrome
ZW2	Window Package – Rear Doors
ZW3	Window Package – Rear Doors, Side Rear Door
ZW4	Window Package – Right Side, Rear Doors
ZW6	Window Package – Complete Body
ZW9	Body Equipment – Base Body or Chassis
ZX1	Seating Arrangement – Driver Only, High Back
ZX2	Seating Arrangement – Driver and Passenger, High Back
ZX5	Seating Arrangement – 12 Passenger
ZX9	Tire Spare – w/Wheel – Delete
Z49	Export – Canadian Modification Mandatory Base Equipment
Z5X	Mirror Provisions – Arabic Language
Z82	Trailer Provisions – Special Equipment, H.D.
Z88	Market Brand – GMC
40P	Wheel Color – White (91)

Body Control System

DESCRIPTION AND OPERATION

The body control system consists of the Body Control Module (BCM), communications, and various input and outputs. Some inputs, outputs and messages require other modules to interact with the BCM. The BCM also has discrete input and output terminals to control the vehicle's body functions. The BCM is wired to the GMLAN High speed serial data bus and the GMLAN Low speed serial data bus and acts as a gateway between them. If the BCM does not communicate the vehicle will not start due to the inability of the Engine/Powertrain Control Module (ECM/PCM) and Vehicle Theft Deterrent (VTD) Control Module to communicate without the BCM providing the gateway function.

POWER MODE MASTER

This vehicle's BCM functions as the Power Mode Master (PMM). The ignition switch is a low current switch with multiple discrete ignition switch signals to the PMM for determination the power mode that will be sent over the serial data circuits to the other modules that need this information, and so the PMM will activate relays and other direct outputs of the PMM as needed.

SERIAL DATA GATEWAY

The BCM in this vehicle functions as a gateway or translator. The purpose of the gateway is to translate serial data messages between the GMLAN high speed bus and the GMLAN low speed bus for communication between the various modules. The gateway will interact with each network according to that network's transmission protocol.

One example of this necessary communication is the communication between the Engine/Powertrain Control Module (ECM/PCM) which is high speed serial data and Vehicle Theft

Deterrent (VTD) Control Module which is low speed serial data. If these modules can not exchange information, the vehicle will not start.

Communication between the BCM and a scan tool can be on the high speed GMLAN network or low speed GMLAN network. If one network is lost, the BCM can still communicate with the scan tool. A lost communication DTC typically is set in modules other than the module with a communication failure.

BODY CONTROL MODULE

The various Body Control Module (BCM) input and output circuits are described in the corresponding functional areas indicated on the BCM electrical schematics. Some BCM functions with the subsystems may be as a gateway only or as an enable for the system. The BCM related systems/subsystems include, but are not limited to the following:

- Anti-lock Brake System (ABS)
- Automatic Day-Night Mirror
- Cruise Control System
- Exterior Lighting
- Horn System
- Instrument Cluster Indicator Control
- Interior Lighting
- Power Door Lock System
- Rear Window Defogger System
- Remote Function Actuation (RFA) Control
- Retained Accessory Power (RAP)
- Shift Lock Control System
- Starting System
- Supplemental Inflatable Restraint (SIR) System
- Vehicle Theft Deterrent (VTD)
- Wiper/Washer System Functions

Data Link Communications – Description & Operation

CIRCUIT DESCRIPTION

The communication among control modules is performed primarily through the GMLAN high speed serial data circuit and the GMLAN low speed serial data circuits. The modules that need real time communication are attached to the high speed GMLAN network. The Body Control Module (BCM) is the serial data gateway between the networks. The purpose of the gateway is to translate serial data messages between the GMLAN high speed bus and the GMLAN low speed bus. The Local Interconnect Network (LIN) is another serial data communication network used on this vehicle which is dedicated to the Remote Compass Module (RCM) subsystem. Below are more detailed descriptions of the individual networks. The gateway will interact with each network according to that network's transmission protocol.

GMLAN HIGH SPEED CIRCUIT DESCRIPTION

The Data Link Connector (DLC) allows a scan tool to communicate with the high speed GMLAN serial data circuit. The serial data is transmitted on two twisted wires that allow speed up to 500 Kb/s. The twisted pair is terminated with two 120 ohms resistors. The resistors are used to reduce noise on the High Speed GMLAN bus during normal vehicle operation. The high speed GMLAN is a differential bus. The high speed GMLAN serial data (+) and high speed GMLAN serial data (-) are driven to opposite extremes from a rest or idle level. The idle level, which is approximately 2.5 volts, is considered recessive transmitted data and is interpreted as a logic 1. Driving the lines to their extremes, adds one volt to the high speed GMLAN serial data (+) and subtracts one volt from the high speed GMLAN serial data (-) wire. This dominant state is interpreted as a logic 0. GMLAN network management supports selective start up and is based on virtual networks. A virtual network is a collection of signals started in response to a vehicle event. The starting of a virtual network

signifies that a particular aspect of the vehicles functionality has been requested. A virtual network is supported by virtual devices, which represents a collection of signals owned by a single physical device. So, any physical device can have one or more virtual devices. The signal supervision is the process of determining whether an expected signal is being received or not. Failsofting is the ability to substitute a signal with a default value or a default algorithm, in the absence of a valid signal. Some messages are also interpreted as a heartbeat of a virtual device. If such a signal is lost, the application will set a no communication code against the respective virtual device. This code is displayed on the Tech 2 screen as a code against the physical device. Note: a loss of serial data DTC does not represent a failure of the module that the code is set in.

GMLAN LOW SPEED CIRCUIT DESCRIPTION

The Data Link Connector (DLC) allows a scan tool to communicate with the low speed GMLAN serial data circuit. The serial data is transmitted over a single wire to the appropriate control modules. The transmission speed for GMLAN low speed is up to 83.33 Kb/s. Under normal vehicle operating conditions, the speed of the bus is 33.33 Kb/s. This protocol produces a simple pulse train sent out over the GMLAN low speed serial data bus. When a module pulls the bus high, 5 volts, this creates a dominant logic state or 0 on the bus. When the bus is pulled low, 0 volts, it is translated as a recessive logic state or 1. To wake the control modules connected to the GMLAN low speed serial data bus, a high voltage wake up pulse is sent out over the bus, the voltage level of the pulse is +10 volts. Modules connected to the GMLAN low speed bus can be part of a virtual network as described in the previous paragraph. Most modules on the GMLAN low speed serial data bus are connected to the bus in a parallel configuration. Refer to the schematics to determine modules that are not in parallel.

Data Link Communications – Description & Operation (cont'd)

LOCAL INTERCONNECT NETWORK (LIN) DESCRIPTION

The Remote Compass Module (RCM) communicates with the BCM utilizing a single wire LIN communication link. The BCM is the gateway for the GMLAN network. All data is communicated on the LIN bus, therefore there are only 3 circuits to the RCM as follows:

- Ground
- LIN bus
- Voltage

DATA LINK CONNECTOR (DLC)

The Data Link Connector (DLC) is a standardized 16-cavity connector. Connector design and location is dictated by an industry wide standard, and provides the following:

- Pin 1 GMLAN low speed communications terminal
- Pin 4 Scan tool power ground terminal
- Pin 5 Common signal ground terminal
- Pin 6 High speed GMLAN serial data bus (+) terminal
- Pin 14 High speed GMLAN serial data bus (-) terminal
- Pin 16 Scan tool power, battery positive voltage terminal

SERIAL DATA REFERENCE

The scan tool communicates over the various busses on the vehicle. When a scan tool is installed on a vehicle, the scan tool will try to communicate with every module that could be optioned into the vehicle. If an option is not installed on the vehicle, the scan tool will display No Comm for that options specific control module. In order to avert misdiagnoses of No Communication with a specific module, refer to Data Link References for a list of modules, the bus they communicate with, and the RPO codes for a specific module.

Electric Power Management – Description & Operation

The Electric Power Management (EPM) is used to monitor and control the charging system and alert the driver of possible problems within the charging system. The EPM system makes the most efficient use of the generator output, improves the battery State of Charge (SOC), and extends battery life.

The idle boost operation is a means of improving generator performance during a low voltage or low battery SOC condition. Idle boost is activated in incremental steps. Idle Boost 1 must be active before Idle Boost 2 can be active. The criteria used by the Body Control Module (BCM) to regulate EPM is outlined below.

IDLE BOOST TABLE

Function	Battery Temperature Calculation	Battery Voltage Calculation	Amp-Hour (AH) Calculation	Action Taken
Idle Boost 1 Start	Less Than -15°C (+5°F)	Less Than 13 V	--	First level idle boost requested
Idle Boost 1 Start	--	--	Battery has a net loss greater than 0.6 AH	First level idle boost requested
Idle Boost 1 Start	--	Less Than 10.9 V	--	First level idle boost requested
Idle Boost 1 End	Greater Than -10°C (+5°F)	Greater Than 12 V	Battery has a net loss less than 0.2 AH	First level idle boost request cancelled
Idle Boost 2 Start	--	--	Battery has a net loss greater than 1.6 AH	Second level idle boost requested
Idle Boost 2 Start	--	Less Than 10.9 V	--	Second level idle boost requested
Idle Boost 2 End	--	Greater Than 12 V	Battery has a net loss of less than 0.8 AH	Second level idle boost request cancelled
Idle Boost 3 Start	--	--	Battery has a net loss of 10.0 AH	Third level idle boost requested
Idle Boost 3 Start	--	Less Than 10.9 V	--	Third level idle boost requested
Idle Boost 3 End	--	Greater Than 12 V	Battery has a net loss of less than 6 AH	Third level idle boost request cancelled

Power Mode – Description & Operation

SERIAL DATA POWER MODE MASTER

Power to many of this vehicle's circuits are controlled by the module that is designated the Power Mode Master (PMM). This vehicle's PMM is the Body Control Module (BCM). The ignition switch is a low current switch with multiple discrete ignition switch signals to the PMM for determination of the power mode that will be sent over the serial data circuits to the other modules that need this information. The PMM will also activate relays and other direct outputs of the PMM as needed. The PMM determines which power mode (Off, Accessory, Run, Crank Request)

is required, and reports this information to other modules via serial data. Modules which have switched voltage inputs may operate in a default mode if the PMM serial data message does not match what the individual module can see from its own connections.

The PMM receives ignition switch signals to identify the operators desired power mode. The PMM Power Mode Parameters table below illustrates the correct state of these input parameters (circuits) in correspondence to the ignition switch position:

PMM POWER MODE PARAMETERS

Ignition Switch Position	Power Mode Transmitted	Ignition Off/Run/Crank (Run Crank Ignition 1 Voltage Circuit)	Ignition Accessory/Run (Accessory Voltage Circuit)	Ignition Run/Crank (Ignition 1 Voltage Circuit)
Off Key OUT	Off	Key Out / ACC	Inactive	Inactive
Off Key IN	Off	Key In / Off	Inactive	Inactive
Accessory	Accessory	Key Out / ACC	Active	Inactive
Run	Run	Run	Active	Active
Start	Crank Request	Crank	Inactive	Active

Power Mode – Description & Operation

RELAY CONTROLLED POWER MODE

The Body Control Module (BCM) uses the discrete ignition switch inputs Run/Crank Ignition 1 Voltage, Accessory Voltage, and Ignition 1 Voltage, to distinguish the correct power mode. The BCM, after determining the desired power mode, will activate the appropriate relays for that power mode.

The RAP relay remains on for a timed period after the Ignition key is removed.

BCM AWAKE / SLEEP STATES

The Body Control Module (BCM) is able to control or perform all of the BCM functions in the awake state. The BCM enters the sleep state when active control or normal monitoring of system functions has stopped and a time limit has passed. The BCM must detect certain wake-up inputs before entering the awake state. The BCM monitors for these inputs during the sleep state.

The BCM will enter the awake state if any of the following wake-up inputs are detected:

- Activity on the serial data line.
- Detection of a battery reconnect.
- Any door open signal.
- Headlamps ON.
- Key-in-ignition.
- Ignition ON.
- Park lamps ON.
- Keyless entry or remote start message.

The BCM will enter a sleep state when all of the following conditions exist:

- The ignition switch is OFF, key out.
- No activity exists on the serial data line.
- No outputs are commanded.
- No delay timers are actively counting.
- No wake-up inputs are present.

If all these conditions are met, the BCM will enter a low power or sleep condition.

Retained Accessory Power (RAP)

DESCRIPTION AND OPERATION

The Retained Accessory Power (RAP) system allows specific vehicle functions to operate for a specific amount of time after the ignition switch is turned OFF. The BCM monitors the ignition switch position, battery condition, and each door ajar/open switch status to determine whether RAP should be initiated or terminated. RAP is controlled with 2 different methods; serial data and relay control. Some modules receive a RAP message over the serial data circuits. Serial data controlled RAP is deactivated as required by their modules RAP power mode operation. Other subsystems are activated directly by the BCM through a RAP relay. Components and systems that are active in RAP are also activated anytime the ignition is any position other than OFF regardless of the door switch signals. The RAP relay is located in the body fuse block, is grounded at G302, and is controlled by the rap relay coil control circuit from the BCM.

RELAY CONTROLLED RAP

The BCM keeps the RAP relay energized during all power modes, except Off-Awake and Crank. The relay is also energized for approximately 10 minutes after shutting the ignition OFF and removing the key, providing no door is opened.

Relay controlled RAP will end when one of the following conditions is met:

- The BCM receives an input from any door ajar switch indicating the opening of any door after the ignition key is out of the ignition.

Important: If the BCM is receiving any door ajar signal from those switches when the ignition key is turned OFF, RAP will not initiate.

- The BCM internal timer for the RAP expires after approximately 10 minutes.
- The BCM detects a decrease in battery capacity below a prescribed limit.

The power window system is powered by the RAP relay during the RAP power mode.

SERIAL DATA CONTROLLED RAP

RAP systems that are controlled by serial data are as follows:

Radio

Radio RAP activation/termination is the same as relay operation with one exception: the only door switch that will turn off the radio during RAP is the driver door open switch.

Fast Idle

AVAILABILITY

1. Fast Idle is not available on Passenger, Cargo w/YF7, or Cargo/Mobility models
2. You must order the 6.6L Duramax® diesel engine (LMM) or the 6.0L gas engine (LY6). **LY6 added for 2009.**
3. You must order Cruise Control (RPO K34)
4. You must order Fast Idle (RPO UF3)

NOTE: Fast Idle (RPO: UF3) must be ordered and cannot be retrofitted.

Bulletin #82 – See this document at:

http://www.gmupfitter.com/publicat/bull/63135_FastIdle_UI_82_D3.pdf

Generators

GENERATOR APPLICATION TABLE

Generator RPO	Generator Output (Amps)	Availability	Engine Displacement / RPO	Generator Make / Model	Generator Part Number	Pulley Ratio
K68	105	All V8 Gas Engines	4.8L (LY2) 5.3L (LMF) 6.0L (LY6)	Bosch / P4	21998419	3.257
K68	105	V6 Gas Engine	4.3L (LU3)	Bosch / P4	94665137	3.257
KG3	145	All Gas Engines	4.3L (LU3) 4.8L (LY2) 5.3L (LMF) 6.0L (LY6)	Delco-Remy / DR44G	15847291	LU3 = 3.015 LY2 = 3.269 LMF = 3.015 LY6 = 3.269
KG3	145	Diesel - Single Generator	6.6L (LMM)	Delco-Remy / AD344	15263859	3.35
KD9	145 x 2	Diesel - Dual Generator	6.6L (LMM)	Delco-Remy / AD344	15263859	3.35

GENERATOR OUTPUT PERFORMANCE

Table 1 - All Gas Engines with K68 (105A)
Pulley Ratio = 3.257

Temp. (°C)	Engine Speed (RPM)				
	600	1000	1400	1800	2200
25	67	88	93	96	100
105	59	76	80	82	85
125	44	61	66	69	73

Table 3 - 4.8L (LY2) & 6.0L (LY6) Gas Engines with KG3 (145A)
Pulley Ratio = 3.269

Temp. (°C)	Engine Speed (RPM)				
	600	1000	1400	1800	2200
25	96	133	145	151	154
105	83	113	123	128	130
125	78	107	116	120	123

Table 2 - 4.3L (LU3) & 5.3L (LMF) Gas Engines with KG3 (145A)
Pulley Ratio = 3.015

Temp. (°C)	Engine Speed (RPM)				
	600	1000	1400	1800	2200
25	86	129	142	149	153
105	75	110	121	127	129
125	71	104	114	119	122

Table 4 - 6.6L (LMM) Diesel Engines with KG3 (145A) or KD9 (145A x 2)
Pulley Ratio = 3.35

Temp. (°C)	Engine Speed (RPM)				
	600	1000	1400	1800	2200
25	98	122	134	140	145
105	85	103	112	120	124
125	80	98	108	113	117

Generators - Installation

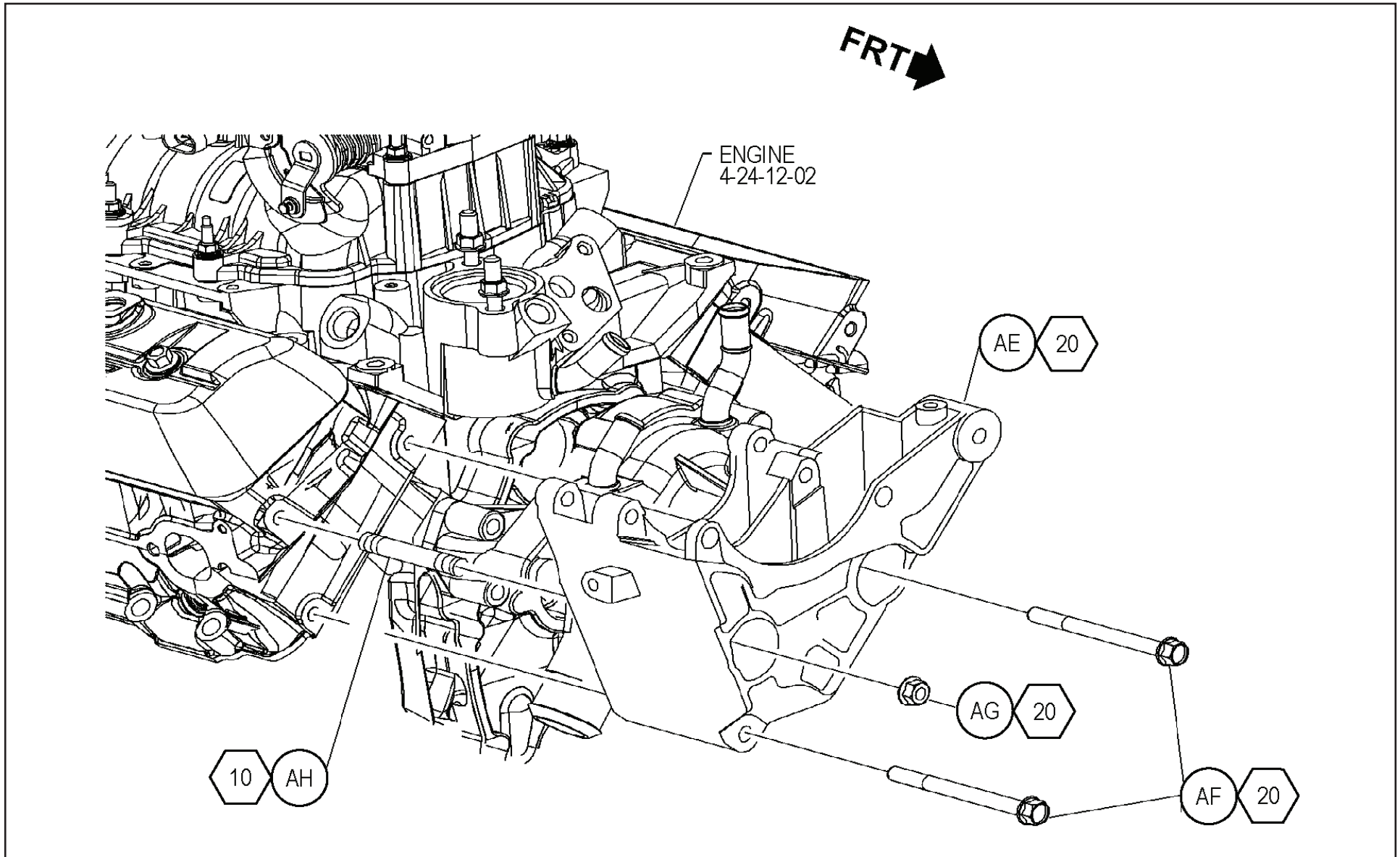

**4.3L (LU3) GENERATOR AND GENERATOR BRACKETRY
INSTALL GEN BRKT TO ENGINE**

Generators – Installation (cont'd)

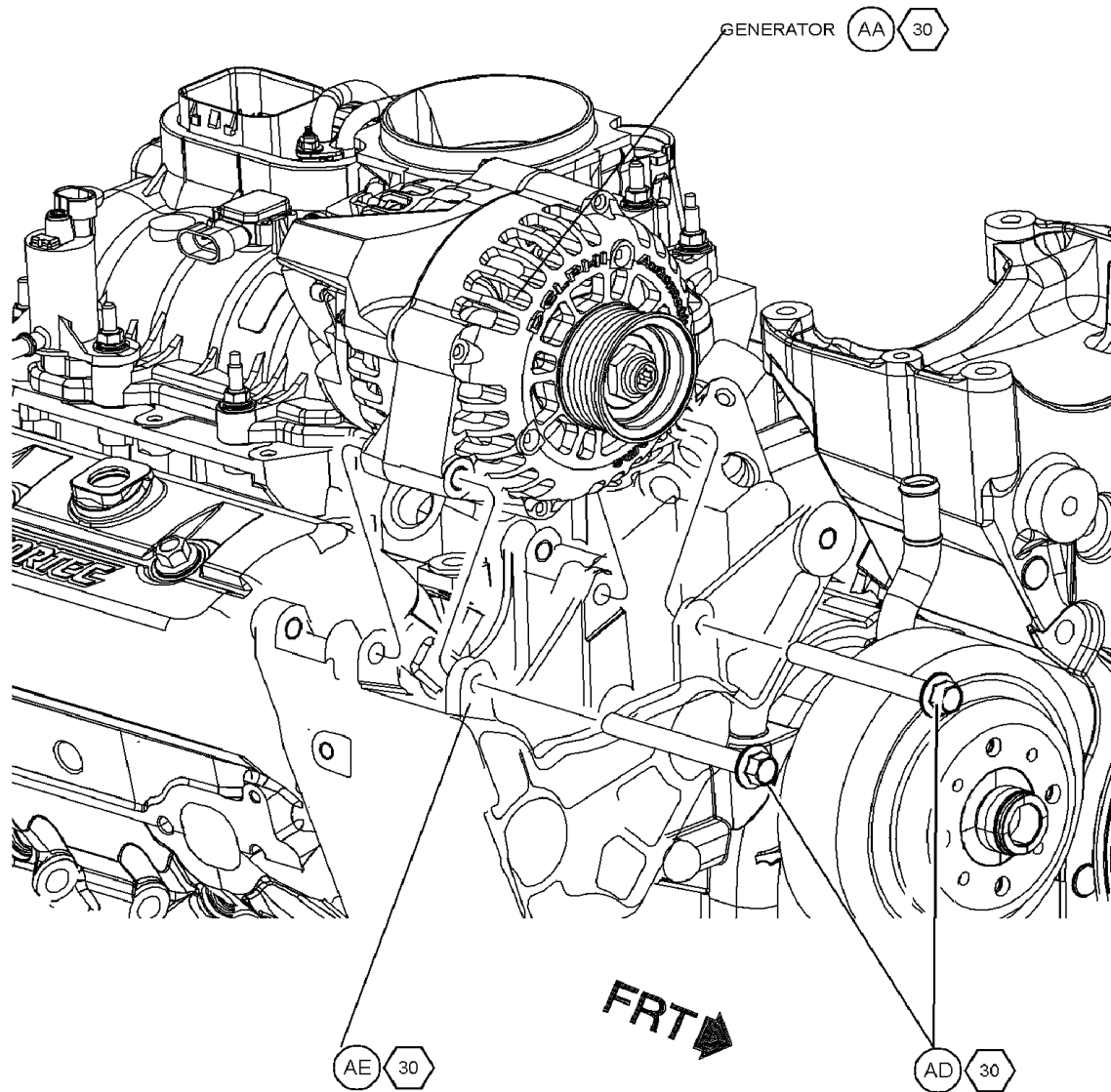

**4.3L (LU3) & 105A (K68) GENERATOR AND GENERATOR BRACKETRY
INSTALL GEN TO ENGINE**

Generators – Installation (cont'd)

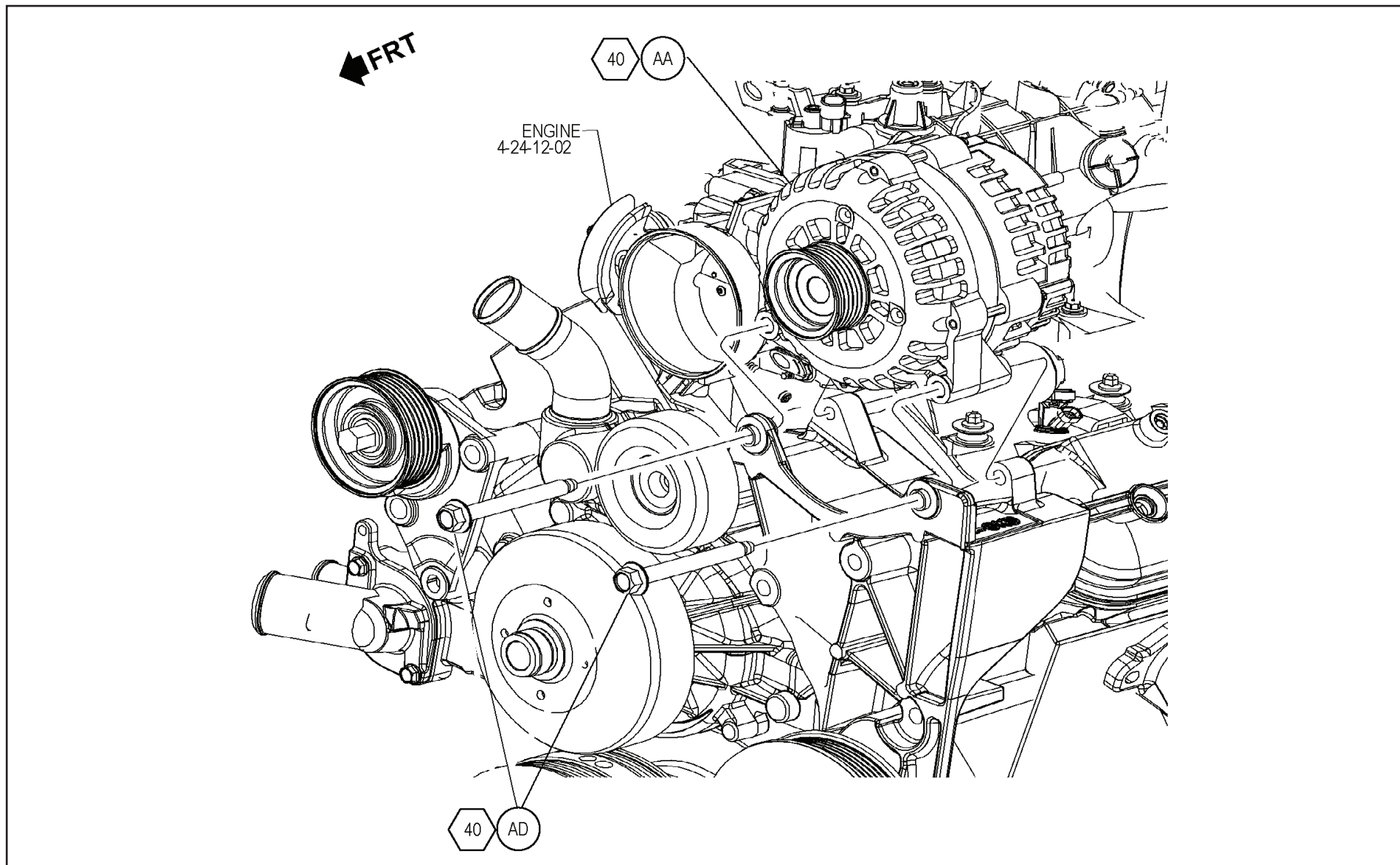

**4.8L (LY2) / 5.3L (LMF) / 6.0L (LY6) & 105A (K68) GENERATOR AND GENERATOR BRACKETRY
INSTALL GEN TO ENGINE**

Generators – Installation (cont'd)

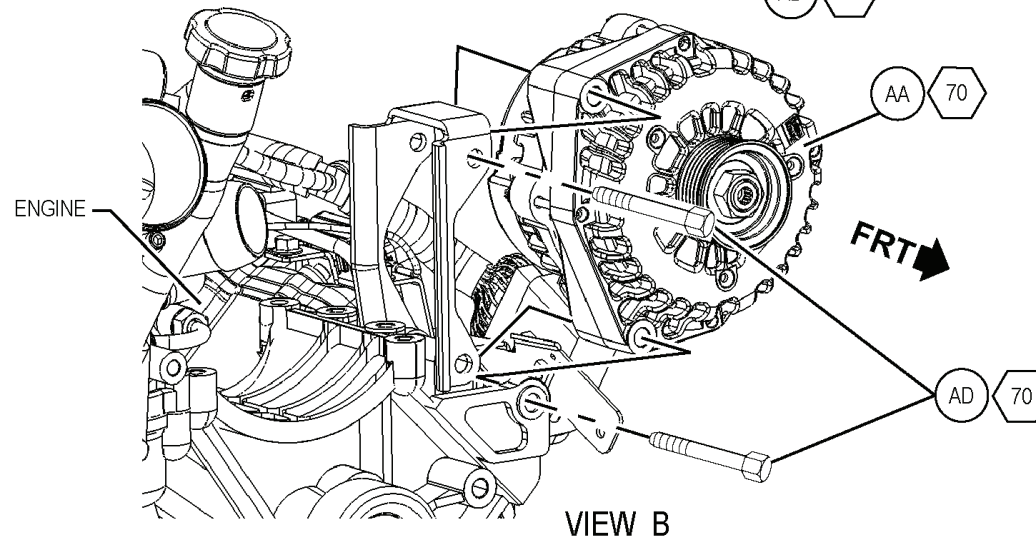
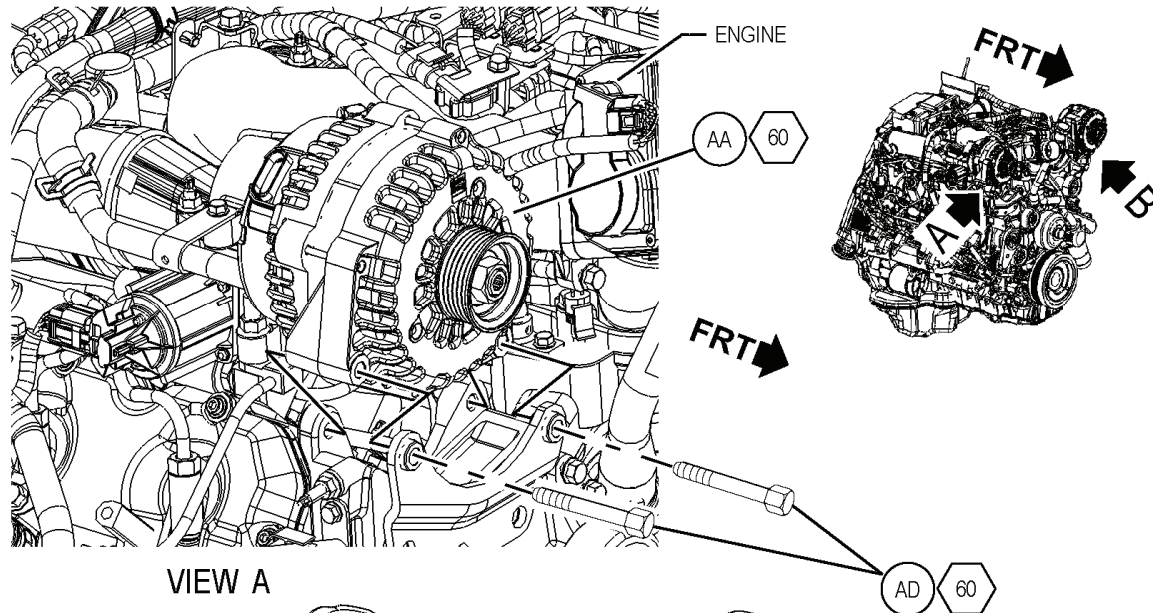

**6.6L (LMM) & DUAL GENERATORS (KD9) & AMBULANCE (YF2) / BUS (B3D) GENERATOR AND GENERATOR BRACKETRY
GENERATOR TO ENGINE**

Generators – Installation (cont'd)

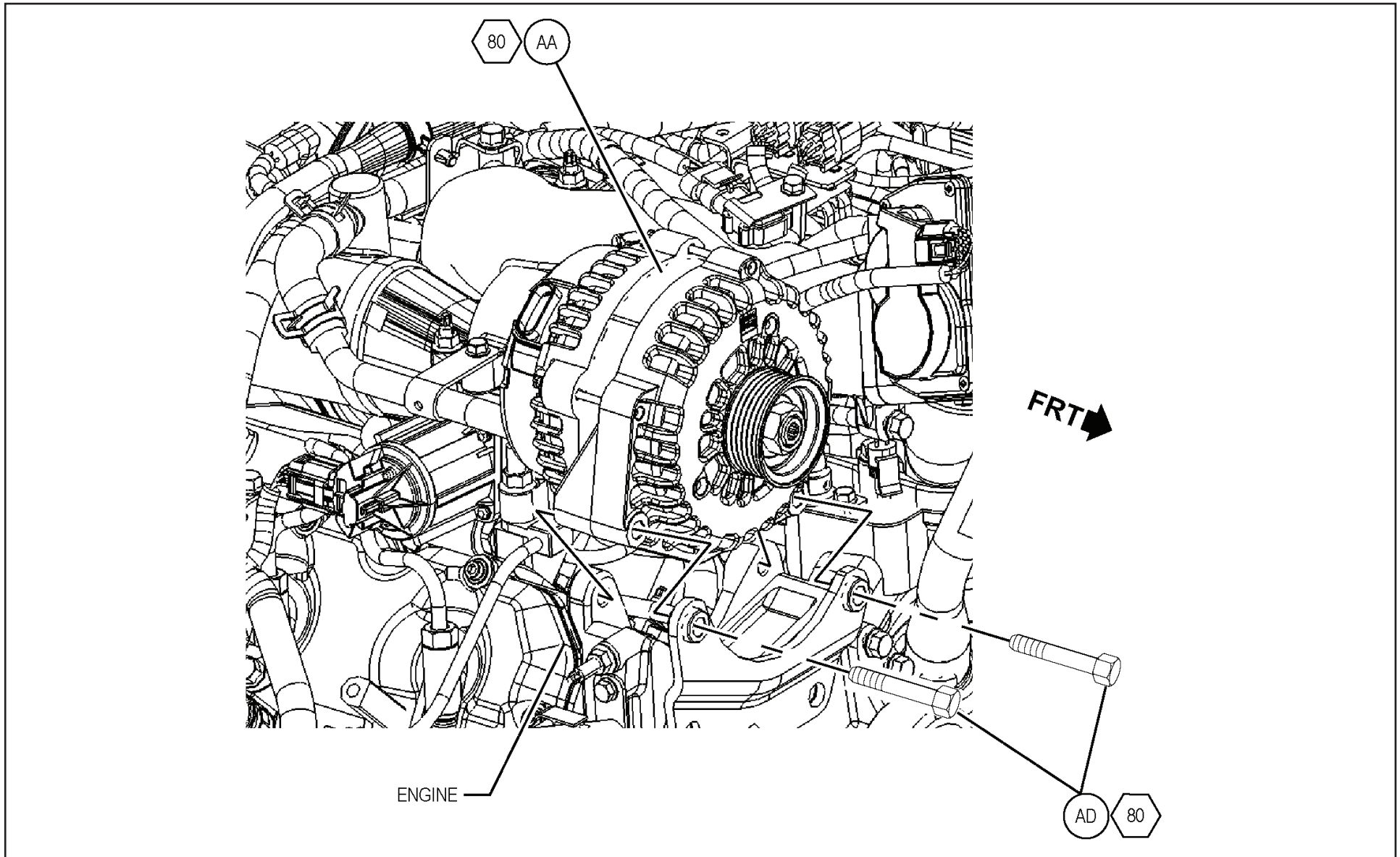

**6.6L (LMM) GENERATOR AND GENERATOR BRACKETRY
GENERATOR TO ENGINE**

Generators – Installation (cont'd)

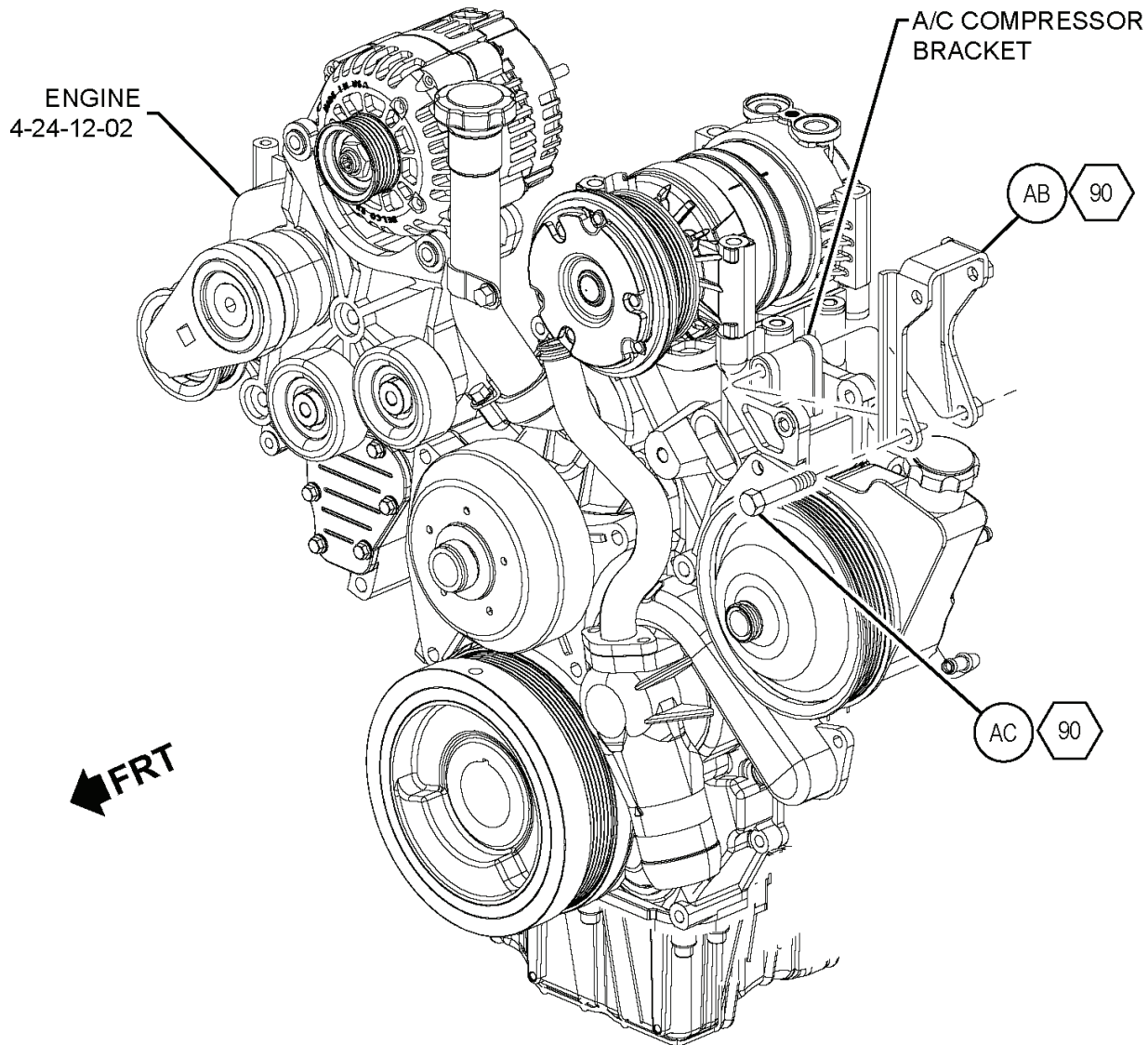

**6.6L (LMM) & DUAL GENERATORS (KD9) GENERATOR AND GENERATOR BRACKETRY
GENERATOR MOUNTING BRACKET – DIESEL ENGINE**

Exterior Lighting Systems – Description and Operation

EXTERIOR LAMPS

The exterior lighting consist of the following lamps:

- Headlamps
- Daytime Running Lamps (DRL)
- Park lamps
- Tail lamps
- License lamps
- Marker lamps
- Turn signal lamps
- Stop lamps
- Center High-Mounted Stop Lamp (CHMSL)
- Backup lamps

LOW BEAM HEADLAMP OPERATION

The headlamps may be turned ON in 3 different ways:

- When the headlamp switch in the HEAD position for normal operations
- When the headlamp switch is in the AUTO position, for Automatic Lamp Control (ALC)
- When the headlamp switch is placed in the AUTO position, with the windshield wipers ON in daylight conditions, after a 6 second delay

Battery voltage is applied at all times to the coil and switch sides of the LOW BEAM PCB Relay located in the underhood fuse block. When the headlamp switch in the headlamps ON position, ground from G303 is applied through the headlamps ON switch signal circuit to the Body Control Module (BCM) signaling the headlamps ON request. In response to this signal, the BCM applies ground through the low beam relay control circuit energizing the LOW BEAM PCB Relay. With the relay energized, battery voltage is applied through the switch side of the relay, the LT and

RT LOW BEAM fuses, and the low beam supply voltage circuits illuminating the low beam headlamps. Ground for the left headlamp is provided at G100 and the right headlamp at G101.

HIGH BEAM HEADLAMP OPERATION

Battery voltage is applied at all times to the coil and switch sides of the HIGH BEAM PCB Relay located in the underhood fuse block. When the headlamp dimmer switch is placed in the high beam position, the headlamp dimmer switch signal circuit to the BCM is pulled low signaling the headlamp high beam request. In response to this signal, the BCM applies ground through the high beam relay control circuit energizing the high beam relay. With the relay energized, battery voltage is applied through the switch side of the relay, the LT and RT HIGH BEAM fuses, and the high beam supply voltage circuits illuminating the high beam headlamps. At the same time the BCM sends a GMLAN serial data message to the instrument panel cluster (IPC) requesting the IPC to illuminate the high beam indicator. Ground for the left headlamp is provided at G100 and the right headlamp at G101.

FLASH TO PASS (FTP)

When the headlamp dimmer switch is pulled toward the driver, the flash to pass signal circuit to the BCM is pulled low signaling the flash to pass request. The BCM then turns ON the high beam headlamps as described above until the headlamp dimmer switch is released. If the low beam headlamps were ON during FTP operation they will remain ON.

Exterior Lighting Systems – Description and Operation (cont'd)

DAYTIME RUNNING LAMPS (DRL) AND AUTOMATIC LAMP CONTROL (ALC)

The low beam headlamps are used for DRL operation at a reduced intensity. The DRLs will operate only with the ignition ON, the headlamp switch in the AUTO position, and the gear selector out of the park position. No other exterior lamps such as the parking lamps, tail lamps, etc. will be on when the DRL are being used. The instrument panel will not be illuminated either.

DRL operation is determined by the ambient light sensor and controlled by the Body Control Module (BCM). The ambient light sensor is a light-sensitive transistor used to monitor outside lighting conditions. The BCM provides a 5-volt reference signal to the sensor while ground is provided at G303. The sensor will vary this voltage signal between 0.2 and 4.9 volts depending on outside lighting conditions. The BCM monitors the ambient light sensor signal circuit to determine if outside lighting conditions are correct for either DRL or ALC operation. When the BCM determines the conditions are met for DRL operation, it applies ground to the DRL relay control circuit energizing the DRL PCB Relay. With the relay energized, battery voltage is applied through the switch side of the relay, the DRL 1 fuse, the DRL 2 fuse, both low beam headlamp fuses, and the low beam supply voltage circuits illuminating the headlamps at a reduced intensity. Any function or condition that turns on the headlamps will cancel DRL operation.

When the BCM detects low light conditions, it will turn OFF the daytime running lamps and turn ON the low beam headlamps as described above in Low Beam Headlamp Operation. The BCM will also turn ON the low beam headlamps in daylight conditions when the windshield wipers are turned ON.

HEADLAMPS SUGGESTED INDICATOR

If the park lamps are turned ON manually and the ambient light sensor detects a low light condition then the Body Control Module (BCM) will send a GMLAN message to the Instrument Panel Cluster (IPC) to display the HEADLAMPS SUGGESTED message.

LIGHTS ON WARNING

The body control module (BCM) activates the lights ON warning as requested by the headlamp dimmer switch. The lights ON warning sounds when the following occurs:

- The key is out of the ignition.
- The BCM determines that the drivers door is open, signal is low.
- The BCM determines that the headlamp switch is in the PARK or HEAD position.

PARK, TAIL, MARKER AND LICENSE LAMPS

The park, tail, and marker lamps are turned ON when the headlamp switch is placed in either the HEAD or PARK lamp positions, or anytime the Automatic Light Control (ALC) turns the headlamps ON. When the headlamp switch is placed in the park lamp or headlamp positions, ground is applied through the switch signal circuit to the BCM indicating the park lamp ON request. In response to this signal, the BCM applies ground through the park lamp relay control circuit energizing the PRK LAMP Relay. With the relay energized, battery voltage is applied through the switch side of the relay, the park lamp fuses, and the supply voltage circuits illuminating the park, license, side marker, and tail lamps. Ground for the front park and side marker lamps is provided at G100 and G101. Ground for the left tail and rear sidemarker lamp is provided at G402, while ground for the right tail, rear side marker, and license lamps is provided at G401.

Exterior Lighting Systems – Description and Operation (cont'd)

TURN SIGNAL LAMPS

The BCM 3, BCM 5, and BCM 6 fuses located in the underhood fuse block supply battery voltage to the Body Control Module (BCM) for turn signal, hazard lamp, and stop lamp operation. Voltage from the BCM 5 fuse used for the front and rear left turn signals, voltage from the BCM 3 for the right front turn signal, while voltage from the BCM 6 fuse is used for the right rear turn signal. When the turn signal switch is placed in either the LEFT or RIGHT position, ground from G303 is applied through the turn signal switch signal circuit to the BCM indicating the turn signal request. In response to this signal, the BCM applies a pulsating voltage to the front and rear turn signal lamps supply voltage circuits cycling the lamps ON and OFF. The BCM also sends a message via GMLAN to the instrument panel cluster (IPC) to cycle the turn signal indicator ON and OFF depending on the position of the turn signal switch.

Ground for the turn signal lamps are listed below:

- G100 provides ground for the left front turn signal lamp
- G347 provides ground for the left outside rearview mirror turn signal lamp
- G101 provides ground for the right front turn signal lamp
- G348 provides ground for the right outside rearview mirror turn signal lamp
- G402 provides ground for the left rear turn signal lamp
- G401 provides ground for the right rear turn signal lamp

HAZARD LAMPS

The hazard flashers may be activated in any power mode. When the hazard lamp switch is placed in the ON position, ground from G303 is applied through the hazard switch signal circuit to the Body Control Module (BCM) indicating the hazard lamps ON

request. In response to this signal, the BCM applies a pulsating voltage through all front and rear turn signal supply voltage circuits cycling the lamps ON and OFF. The BCM also sends a GMLAN serial data message to the instrument panel cluster (IPC) to cycle both turn signal indicators ON and OFF.

STOP LAMPS

Battery voltage from the BCM 5 and BCM 6 fuses located in the underhood fuse block supply is used by the body control module (BCM) for stop lamp operation. Voltage from the BCM 5 fuse used for the left stop lamp and voltage from the BCM 6 fuse is used for the right stop lamp.

Battery voltage from the BCM is supplied through the 12-volt reference circuit, the stop lamp switch, and the brake switch signal circuit back to the BCM. When the brake pedal is applied, the stop lamp switch contacts open and the reference voltage to the BCM is interrupted signaling the stop lamps ON command. In response to this signal, the BCM applies B+ through the left and right turn/stop lamp control circuits and the Center High-Mounted Stop Lamp (CHMSL) control circuit illuminating the stop lamps. The BCM also applies B+ through the stop lamp relay supply voltage circuit energizing the STOP LAMPS PCB Relay. With the relay energized, B+ is applied through the switch side of the relay, the AUX STOP LAMP fuse, and the control circuit to the auxiliary stop lamps. At the same time the BCM signals the transmission control module (TCM) and the engine control module (ECM) that the brakes are applied. Ground for the left stop lamp is provided at G402 and ground for the right stop lamp is provided at G401. The stop lamps on this vehicle will not illuminate unless the ignition is in the accessory, run, or crank positions. When the ignition is in the OFF position the stop lamps will not illuminate when the brake pedal is applied.

Exterior Lighting Systems – Description and Operation (cont'd)

BACKUP LAMPS

When the gear selector is placed in the REVERSE position, the Powertrain Control Module (PCM) sends a GMLAN serial data message to the BCM indicating the backup lamps ON request. The BCM then applies battery voltage through the backup relay control circuit energizing the BCK/UP LAMP PCB Relay. With the relay energized, battery voltage is applied through the switch side of the relay, the T/LAMP BCK/UP fuse, the AUX/TRLR BCK/UP fuse and the supply voltage circuits illuminating the left and right backup lamps and the backup alarm. Ground for the left backup lamp is provided at G402, for the right backup lamp is provided at G401, and ground for the backup alarm is provided at G400.

REAR FOG LAMPS

The rear fog lamps are located in the rear bumper. The fog lamps will operate only when the ignition in the RUN or CRANK positions. When the rear fog lamp switch is turned ON, ground from G303 is applied through the rear fog lamp switch signal circuit to the body control module (BCM) indicating the rear fog lamps ON request. In response to this signal, the BCM applies ground to the rear fog lamp relay control circuit energizing the REAR FOG LP PCB Relay. With the relay energized, battery voltage is applied through the switch side of the relay, the RR FOG LP fuse

and the rear fog lamp supply voltage circuit to the left and right rear fog lamps. The BCM sends a GMLAN serial data message to the instrument panel cluster (IPC) requesting the rear fog lamp indicator be illuminated. The rear fog lamps will deactivate if the headlamps are turned OFF, if the ignition is turned to the OFF position upon a key cycle, or if the driver turns the rear fog lamp switch OFF. Ground for the left fog lamp is provided at G402, and the right fog lamp at G401.

BATTERY RUNDOWN PROTECTION / INADVERTENT POWER

The BCM controls the lighting system through circuits that enable the exterior lamp functions of the park lamps, the head lamps, the fog lamps, and the interior lamps. The BCM will open these enabling circuits 10 minutes after the ignition switch is turned OFF with no lamp switch activity. If the ignition switch is turned to any position other than OFF, or if a lamp switch is activated during this time period, the timer will reset for another 10 minutes.

Exterior Lighting Systems – Bulb Replacement Procedures

BULB REPLACEMENT

For any bulb changing procedure not listed in this section, contact your dealer/retailer.

HALOGEN BULBS

CAUTION: Halogen bulbs have pressurized gas inside and can burst if you drop or scratch the bulb. You or others could be injured. Be sure to read and follow the instructions on the bulb package.

HEADLAMPS

To remove the headlamp assembly from the vehicle and access the bulbs:

1. Open the hood.
2. Remove the two bolts from the headlamp assembly (A).
3. Remove the two pins on the top of the headlamp assembly. To remove the pins, turn the outer pin clockwise and pull it straight up. To remove the inner pin, turn it counterclockwise and pull it straight up.
4. Lift the inboard side of the headlamp to release the inboard tab from the radiator support.
5. Lift the outboard side of the headlamp to release the outboard tab from the radiator support.
6. Lower the headlamp to allow the vertical adjuster to clear the tie bar.
7. Turn the headlamp forward and upward to remove it from the grille.

8. Turn the bulb connector counterclockwise and pull it out of the housing.
9. Without removing the headlamp assembly itself, remove the bulb socket from the back of the headlamp on the driver's side.
10. Turn the bulb counterclockwise one quarter turn to remove it from the socket.
11. On the passenger's side, turn the bulb clockwise one turn.
12. Install the new bulb into the socket then reinstall it into the headlamp assembly (B).
13. Reverse the steps to reinstall the headlamp assembly

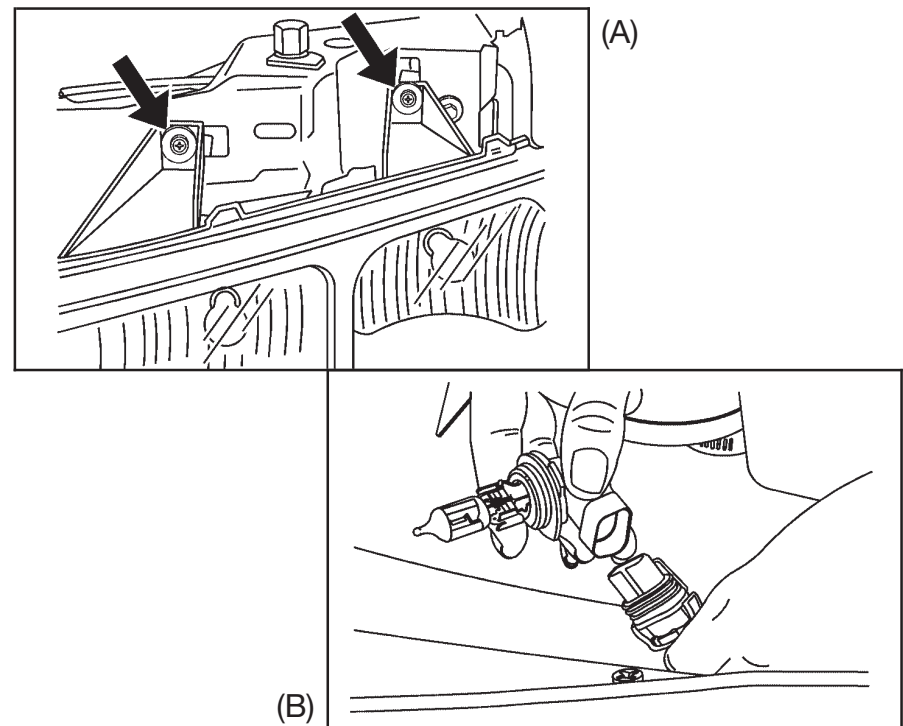

Exterior Lighting Systems – Bulb Replacement Procedures (cont'd)

FRONT TURN SIGNAL, SIDEMARKER AND PARKING LAMPS

To replace the front turn signal, sidemarker and/or parking lamp bulb(s):

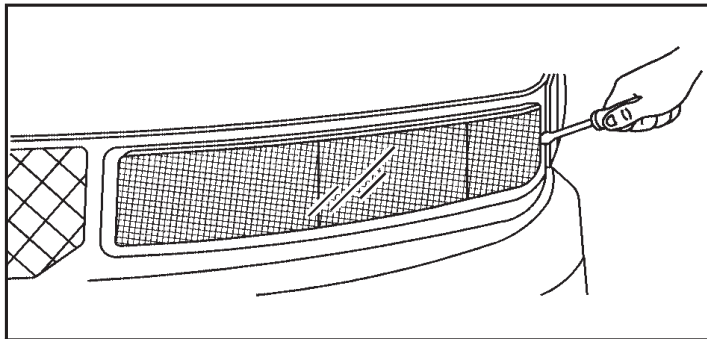

1. Use a small tool to unlatch the outboard clip on the lamp.
2. Pull the lamp forward to completely unlatch the clip. Move the lamp to the outboard side to loosen the tabs.
3. Remove the lamp from the grille.
4. Squeeze the tab on the side of the bulb socket while turning it counterclockwise.
5. Remove the bulb socket from the back of the lamp assembly.
6. Replace the bulb.
7. Turn the bulb socket clockwise to reinstall it in the lamp assembly.

CENTER HIGH-MOUNTED STOPLAMP (CHMSL)

To replace the Center High-Mounted Stoplamp (CHMSL) bulb:

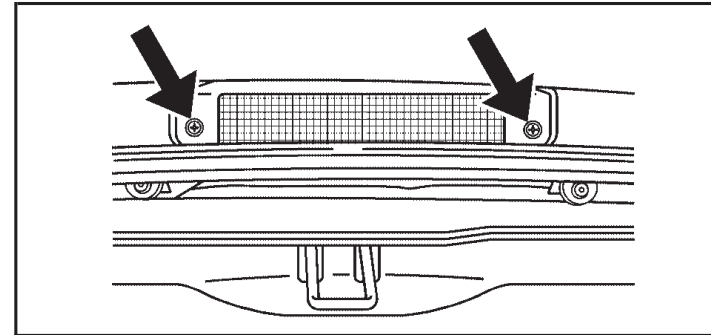

1. Remove the two screws from the CHMSL assembly.
2. Remove the CHMSL assembly.
3. Turn the bulb counterclockwise one quarter turn to remove it from the socket.
4. Turn the bulb clockwise one quarter turn to install it in the socket.
5. Reinstall the CHMSL assembly and two screws. Do not block or damage the CHMSL when items are loaded on the roof of the vehicle.

Exterior Lighting Systems – Bulb Replacement Procedures / Replacement Bulb List

TAIL LAMPS

To replace one of the Tail lamp bulbs:

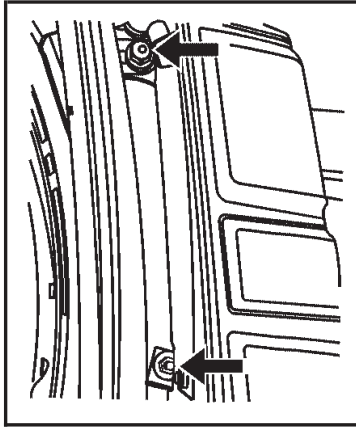

1. Remove the two in-board nuts from the inside of the tail lamp assembly.

2. Pull the tail lamp assembly straight back to clear the studs.
3. Slide the tail lamp assembly slightly upward to release the lower clip.
4. Remove the three nuts on the tail lamp assembly.
5. Remove the tail lamp assembly from the vehicle.

6. Remove the bulb socket by squeezing the tab on the side of the socket while turning it counterclockwise.

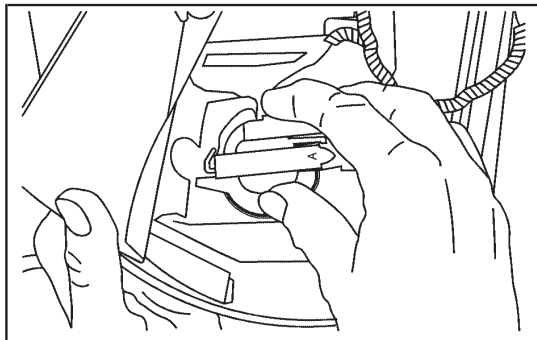

7. Turn the bulb counterclockwise to remove it.
8. Turn the bulb clockwise to install it in the socket.
9. Reinstall the bulb socket by squeezing the tab while turning it clockwise.
10. Reinstall the tail lamp assembly and three nuts on the vehicle.
11. Slide the tail lamp slightly downward to re-engage the lower clip.
12. Push the tail lamp straight forward to re-engage the studs.
13. Reinstall the two inboard nuts from the inside of the tail lamp assembly.

REPLACEMENT BULBS

Exterior Lamp	Bulb Number
Back-up	3157
Rear Parking	3157
Stop	3157
Turn Signal	3157
CHMSL	912
Front Parking	3157KX
Turn Signal	3157KX
Front Sidemarker	194
Headlamps	
Composite High-Beam	9005
Composite Low-Beam	9006GS
Sealed Beam	H6054

For replacement bulbs not listed here, contact your dealer/retailer.

Interior Lighting Systems – Description and Operation

The interior lighting consist of two groups; lamps that may not be manually dimmed (Interior Lamps) and lamps that may be dimmed (Interior Lamps Dimming).

The first group listed below includes lamps that may not be dimmed:

- Front dome/reading lamps
- Middle dome/reading lamps
- Rear dome/reading lamps
- Sunshade Mirror Lamps
- Underhood Lamp

INTERIOR LAMPS FEATURES

The interior lamps system features the following functions:

- An illuminated entry feature that illuminates the courtesy lamps when entering the vehicle or activating the remote keyless entry system.
- An illuminated exit feature that illuminates the courtesy lamps when the ignition key has been removed from the ignition.
- An inadvertent power feature that supplies voltage to all interior lamps after the ignition is turned OFF. The inadvertent power feature will deactivate all interior lamps after 10 minutes to prevent battery rundown.
- A theater dimming feature that will slowly dim the interior lamps from full brightness to OFF.
- Individual switches for control of each interior lamp that is not illuminate with the interior lamp switch.

COURTESY LAMPS (-YF2/YF7)

When any one of the doors is opened, ground is applied through the door latch door open switch and the door open switch signal.

Trailer Wiring Harness (UY7)

The optional heavy-duty trailer wiring package (UY7) includes a wiring harness, with a seven-pin connector at the rear of the vehicle and a four-wire harness assembly under the driver side of the instrument panel. The four-wire harness assembly comes without a connector.

If your vehicle does not have a trailer hitch, the seven-wire harness assembly with connector is taped together and located in a frame pocket at the driver side rear left corner of the frame. If your vehicle has a trailer hitch, the seven-wire harness assembly with connector is attached to a bracket on the hitch platform. In both cases, the seven-wire harness has a connector and includes a 30-amp feed wire.

The seven-wire harness connector contains the following trailer circuits:

- Light Green: Back-up Lamps (10A fuse)**
- White: Ground
- Dark Blue: Trailer Brake Signal
- Dark Green: Right Rear Stop and Turn Signal*
- Red/Black Stripe: Battery Feed (30A Fuse)
- Brown: Trailer Park Lamp Supply Voltage (15A fuse)**
- Yellow: Left Rear Stop and Turn Signal *

The four-wire harness (without connector) contains the following circuits:

- Black: Ground
- Red/White: Battery Feed
- Dark Blue: Trailer Brake Signal
- Light Blue: CHMSL/Stoplamp Supply Voltage

* If your vehicle is a cutaway with trailer provisions, a 15 amp fuse will be shared for both left/stop trailer turn and right/stop trailer turn signals. However, the cutaway lighting connector will have a 10 amp fuse for each signal.

** If your vehicle is a cutaway with trailer provisions, a 15 amp fuse will be shared for trailer park lamps and cutaway rear lighting connector park lamps. Also, a 10 amp fuse will be shared for trailer back-up lamps and cutaway rear lighting connector back-up lamp.

Trailer Connector/Provision Schematics

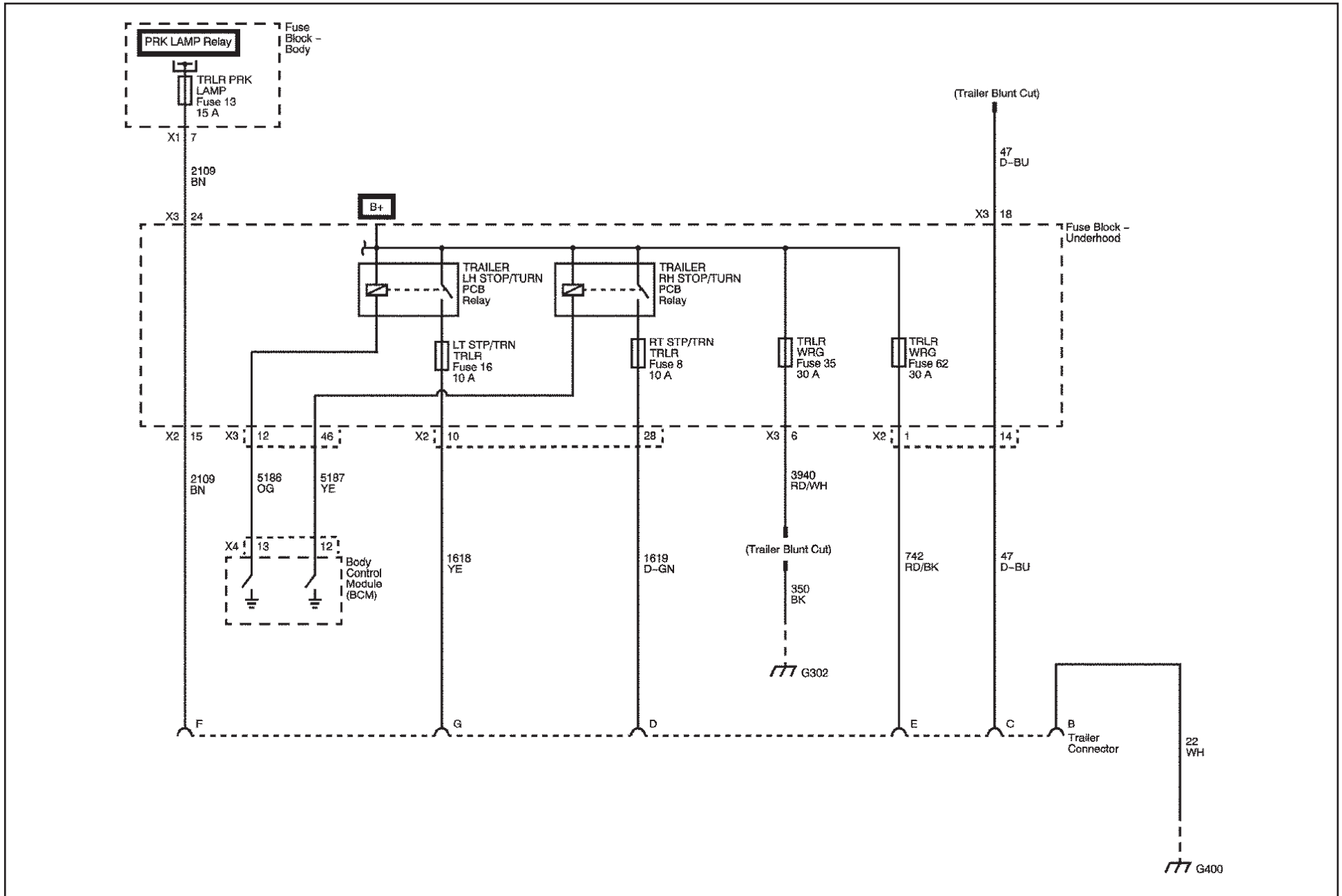

Trailer Connector (UY7)

Connector Part Information

OEM: 15354653

Service: 15354653

Description: 7-Way
F Metri-Pack 280, Sealed (BK)

Terminal Part Information

Pins: A-G

Terminal/Tray: 12110845/4

Core/Insulation Crimp: Pins A,B,D,F,G - See Terminal Repair Kit

Core/Insulation Crimp: Pins C, E-F/5

Release Tool/Test Probe: 15315247/J-35616-4A (PU)

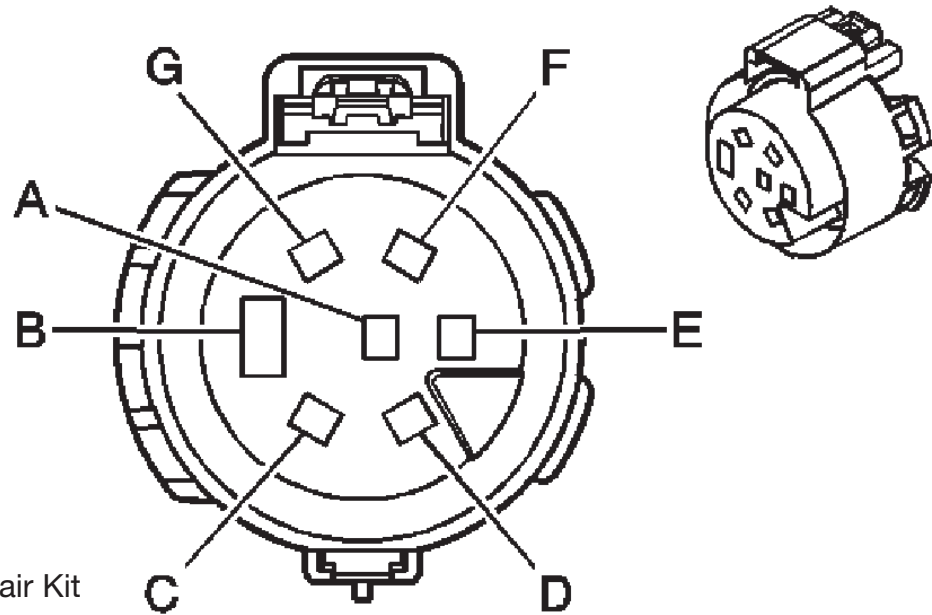

Pin	Wire Color	Circuit No.	Function
A	1 L-GN	1624	Trailer Backup Lamps Control
B	8 WH	22	Ground
C	3 D-BU	47	Trailer Auxiliary Control
D	1 D-GN	1619	Trailer Right Rear Turn/Stop Lamp Control
E	3 RD/BK	742	Battery Positive Voltage
F	1 BN	2109	Trailer Park Lamps Control
G	1 YE	1618	Trailer Left Rear Turn/Stop Lamp Control

Trailer Connector (UY7) Location

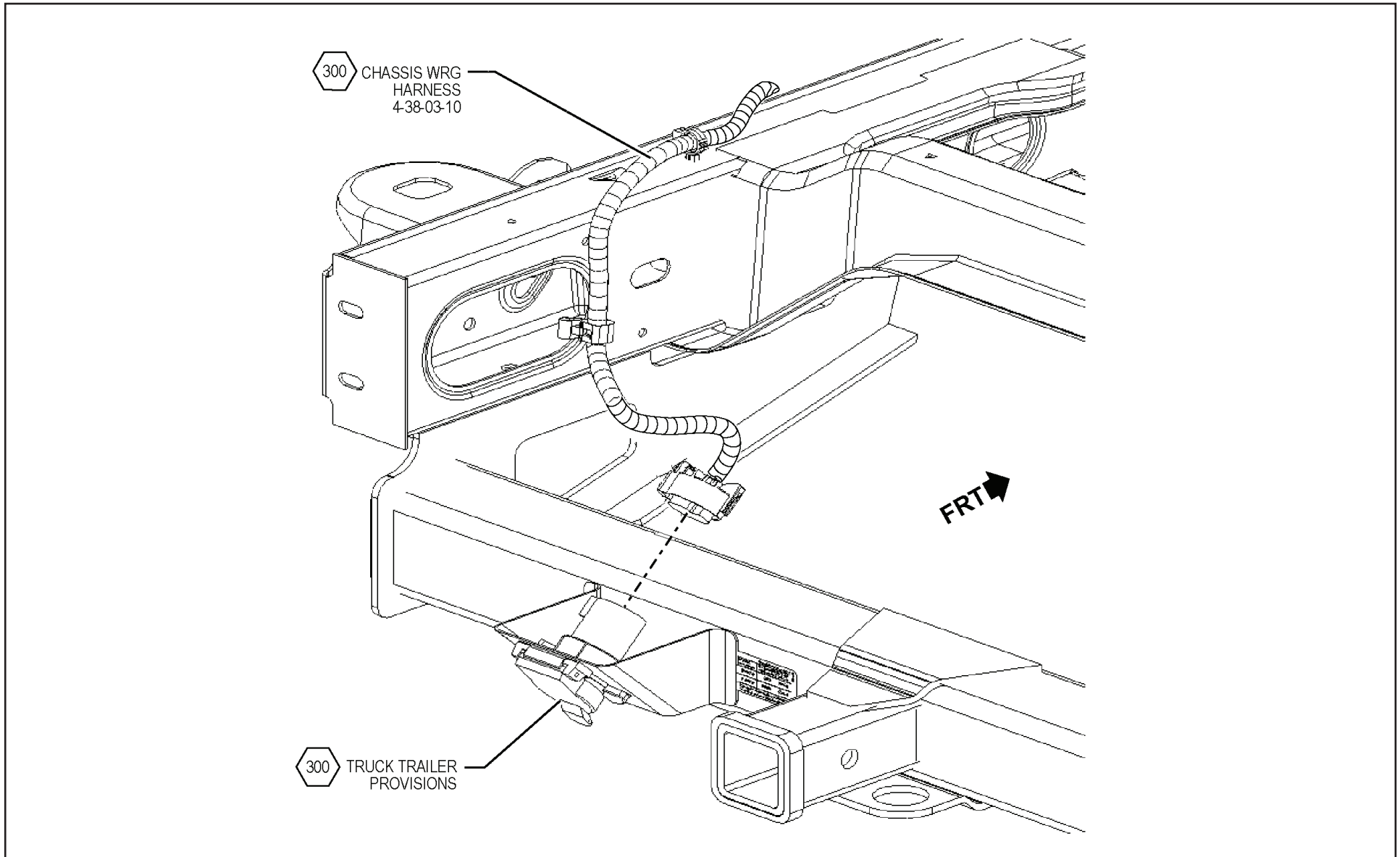

**CHASSIS HARN LEADS AND GROUNDS – ROUTE AND CONNECT
CONNECT CHASSIS WRG HARNESS TO TRUCK TRAILER PROVISIONS**

Automatic Transmission Shift Lock Control – Description and Operation

The automatic transmission shift lock control system is a safety device that prevents an inadvertent shift out of PARK when the engine is running. The driver must press the brake pedal before moving the shift lever out of the PARK position. The system consists of the following components:

- The automatic transmission shift lock solenoid (serviced as the automatic transmission shift lock actuator), as well as the Body Control Module (BCM) and the Engine Control Module (ECM). The shift lock solenoid is located within the floor shift control assembly with vehicles equipped with floor shift.
- The Body Control Module (BCM) controls the voltage supply circuit of the shift lock control solenoid. The following conditions must be before the BCM will remove voltage from the shift lock control solenoid.

The BCM controls the voltage to the shift lock control solenoid through the shift lock control solenoid controlled voltage circuit. The following conditions must be met before the BCM will remove voltage from the shift lock solenoid:

- The ignition is in the ON position.
- The Engine Control Module (ECM) sends an input via GMLAN serial data to the BCM indicating the transmission is in the PARK position.
- The BCM determines the brake pedal is applied according the brake pedal position.

Since the shift lock control solenoid is permanently grounded, the BCM supplies voltage to the automatic transmission shift lock control solenoid, mechanically locking the shift lever preventing the driver from moving the shift lever out of the PARK position as the solenoid energizes. When the brake pedal is not applied, the BCM turns the control voltage output of the shift lock control solenoid ON, energizing the shift lock control solenoid. The energized solenoid mechanically locks the shift lever in the PARK position.

During remote start operation, the BCM will energize the shift lock control circuit, locking the shift lever in the PARK position.

Automatic Transmission Shift Lock Control - Schematic

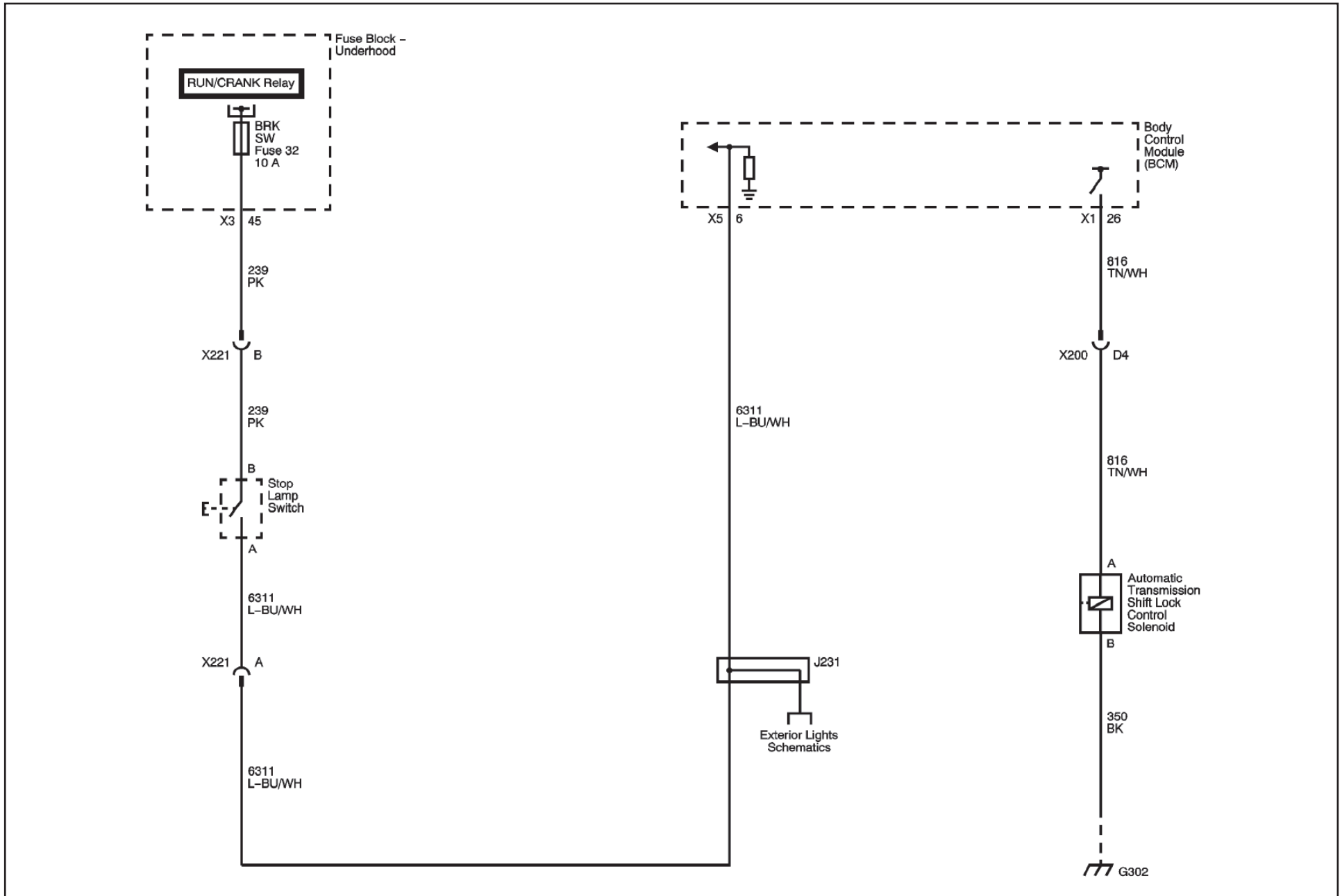

Diesel Particulate Filter (DPF) – System Description

DIESEL PARTICULATE FILTER

The Exhaust Particulate Filter (EPF) captures diesel exhaust gas particulates, preventing their release into the atmosphere. This is accomplished by forcing particulate-laden exhaust (1) through a filter substrate of porous cells, which removes the particulates from the exhaust gas. The exhaust gas enters the filter, but because every other cell of the filter is capped at the opposite end, the exhaust particulates cannot exit the cell. Instead, the exhaust gas passes through the porous walls of the cell leaving the particulates trapped on the cell wall. The cleaned exhaust gas exits the filter through the adjacent cell. The EPF is capable of reducing more than 90 percent of particulate matter (PM).

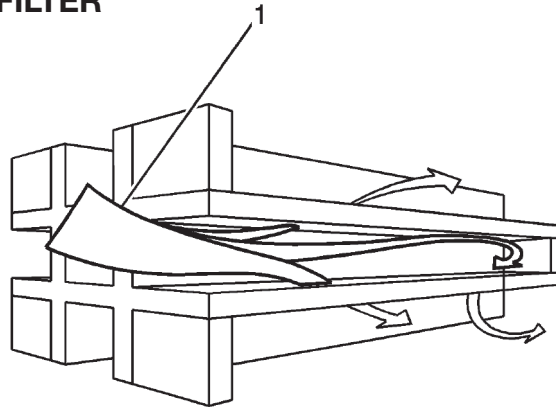

DIESEL OXIDATION CATALYST

The Diesel Oxidation Catalyst (DOC) (7) has two functions. One function is to reduce emissions of Non-Methane Hydro-Carbons (NMHC) and carbon monoxide (CO), from the exhaust gases. The other function is to help start a regeneration event by converting the fuel-rich exhaust gases to heat. The Engine Control Module (ECM) monitors the functionality of the DOC by determining if the exhaust gas temperature (EGT) sensor 1 (1) reaches a predetermined temperature during a regeneration event. The DOC and the exhaust particulate filter (EPF) (6) are downstream of the turbocharger, and are two separate components under the vehicle.

DIESEL PARTICULATE FILTER LAYOUT

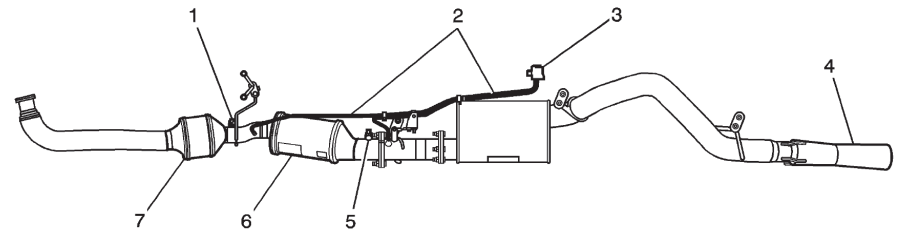

- (1) Exhaust Gas Temperature (EGT) Sensor 1
- (2) Differential Pressure Sensor (DPS) Pressure Lines
- (3) Differential Pressure Sensor (DPS)
- (4) Exhaust Cooler
- (5) Exhaust Gas Temperature (EGT) Sensor 2
- (6) Exhaust Particulate Filter (EPF)
- (7) Diesel Oxidation Catalyst (DOC)

DIFFERENTIAL PRESSURE SENSOR (DPS) AND PRESSURE LINES

The Differential Pressure Sensor (DPS) (3) measures the pressure difference between the inlet and outlet of the Exhaust Particulate Filter (EPF). When pressure difference has increased above a calibrated threshold, a high particulate loading condition is indicated. The ECM will command a regeneration event in order to restore the filter. If the pressure differential continues to increase across the exhaust filter without a regeneration event, the ECM will illuminate an EPF lamp or send a message to the Driver Information Center (DIC) referring the customer to clean the exhaust

Diesel Particulate Filter (DPF) – System Description (cont'd)

filter. To clean the exhaust filter the vehicle must be driven under the conditions necessary for a regeneration to take place. If these lamps and messages are ignored, the ECM will eventually illuminate the malfunction indicator lamp (MIL) and revert to Reduced Engine Power which will require the vehicle to be serviced.

The DPS sensor provides a voltage signal to the ECM on a signal circuit relative to the pressure differential changes in the EPF. The ECM converts the signal voltage input to a pressure value.

The DPS pressure lines (2) are connected before and after the EPF. To provide the pressure sensor with accurate back pressure measurements, the DPS pressure lines should have a continuous downward gradient, without any sharp bends or kinks.

EXHAUST GAS TEMPERATURE SENSORS

The ECM uses two Exhaust Gas Temperature (EGT) sensors to measure the temperature of the exhaust gases at the inlet and outlet of the Exhaust Particulate Filter (EPF). The EGT sensors are variable resistors, when the EGT sensors are cold, the sensor resistance is low, and as the temperature increases, the sensor resistance increases. When sensor resistance is high, the ECM detects a high voltage on the signal circuit. When sensor resistance is low, the ECM detects a lower voltage on the signal circuit. Proper EGTs at the inlet and outlet of the EPF are crucial for proper operation and for initiating the regeneration process. A temperature that is too high in the EPF will cause the EPF substrate to melt or crack. The ECM monitors the temperatures at the EPF inlet and outlet to regulate EPF temperatures.

INTAKE AIR (IA) VALVE

The intake air (IA) valve is located upstream of the intake air heater, and is normally in the open position. The ECM commands

the valve to close in order to precisely control combustion temperature control during Exhaust Particulate Filter (EPF) regeneration. The IA valve will ensure the temperature of the exhaust gas remains in an efficient range under all operating conditions. The IA valve system uses a position sensor located within the valve assembly to monitor the position of the valve. The IA valve uses a motor to move the valve to a closed position and spring tension returns it to the open position. The motor is operated through Motor Control 1 and 2 circuits.

EXHAUST COOLER

The exhaust system has been designed to reduce exhaust gas temperatures during regeneration. The exhaust cooler (4) at the end of the tailpipe draws in cooler air as exhaust gases flow through its openings. The cooler air mixes with the warmer exhaust gas, reducing exhaust gas temperatures at the tailpipe outlet.

NORMAL REGENERATION

Regeneration is the process of removing the captured particulates through incineration within the Exhaust Particulate Filter (EPF). Elevated temperatures are created in the Diesel Oxidation Catalyst (DOC) through a calibrated strategy in the engine control system.

Regeneration occurs when the ECM calculates that the particulate level in the filter has reached a calibrated threshold using a number of different factors, including engine run time, distance traveled, fuel used since the last regeneration, and the exhaust differential pressure. In general, the vehicle will need to be operating continuously at speeds above 48 km/h (30 mph) for approximately 20-30 minutes for a full and effective regeneration to complete. During regeneration the exhaust gases reach temperatures above 550°C (1,022°F). The ECM monitors the EGT sensors

Diesel Particulate Filter (DPF) – System Description (cont'd)

during regeneration. If the sensors indicate that regeneration temperatures are exceeding a calibrated threshold, regeneration will be temporally suspended until the sensors return to a normal temperature. If EGT temperatures fall below a normal calibrated threshold, regeneration will be terminated and a corresponding DTC should set. If a regeneration event is interrupted for any reason, it will continue, including the next key cycle, when the conditions are met for regeneration enablement. Normal regeneration is transparent to the customer.

SERVICE REGENERATION

Caution: Tailpipe outlet exhaust temperature will be greater than 300°C (572°F) during service regeneration. To help prevent personal injury or property damage from fire or burns, perform the following:

1. Do not connect any shop exhaust removal hoses to the vehicle's tailpipe.
2. Park the vehicle outdoors and keep people, other vehicles, and combustible material away during service regeneration.
3. Do not leave the vehicle unattended.

Caution: To avoid extremely elevated exhaust temperatures, inspect and remove any debris or mud build up at the exhaust cooler located at the tailpipe.

Notice: Due to the elevated engine temperatures created while performing this procedure it is imperative to keep the front of vehicle in an open environment, with the hood open, away from any walls or buildings. This will ensure proper airflow across the radiator.

A scan tool is an essential tool that is required for service regeneration. Commanding a service regeneration is accomplished using the output control function. The vehicle will need to be parked outside the facility and away from nearby objects, such

as other vehicles and buildings, due to the elevated exhaust gas temperature at the tail pipe during regeneration. The service regeneration can be terminated by applying the brake pedal, commanding service regeneration OFF using the scan tool, or disconnecting the scan tool from the vehicle.

REGENERATION PROCESS

A number of engine components are required to function together for the regeneration process to be performed. These components are the fuel injectors, turbocharger, IA valve, fuel pressure control, and the Intake Air Heater (IAH).

The regeneration process consists of several stages:

Warming up the diesel oxidation catalyst (DOC) to 350°C (662°F) by performing the following:

- Reducing air flow with the intake air valve
- Increasing or decreasing boost pressure with the turbocharger, depending on engine load
- Elevating the engine speed
- Reduce fuel rail pressure
- Retard fuel injection timing
- Add late fuel injection pulses. The added fuel is not combusted but is oxidized by the DOC and Exhaust Particulate Filter (EPF) to create heat.

ASH LOADING

Ash is a non-combustible by product from normal oil consumption. Low Ash content engine oil (CJ-4 API) is required for vehicles with the Exhaust Particulate Filter (EPF) system. Ash accumulation in the EPF will eventually cause a restriction in particulate filter. Regeneration will not burn off the ash, only particulate matter is burned off. An ash loaded EPF will need to be removed from the vehicle and cleaned or replaced.

Diesel Particulate Filter (DPF) – Regeneration Enable

Important:

The DPF Regeneration Enable is required when specific service procedures have been performed. Do not perform a DPF Regeneration Enable unless instructed to in the Repair Instruction section of the service procedure. After the system repair, perform the following to avoid possible damage to the DPF:

1. Ignition ON, clear all DTCs with a scan tool.
2. Select DPF Regeneration Enable within the Special Function menu.
3. Select ON.

The selection can be confirmed by the DPF Regeneration Reason parameter indicating Device Control.

4. Exit the Special Function Menu.
The scan tool can now be removed.

The vehicle will perform an active Regeneration as soon as the engine running conditions are met.

Diesel Particulate Filter (DPF) – Service Regeneration

Service Regeneration Successful

DPF Regeneration Parameters	Successful Regeneration
DPF Regeneration Status	Complete
DPF Regeneration Reason	None
DPF Regeneration Inhibit Reason	None

Service Regeneration Unsuccessful

The scan tool DPF Regeneration Inhibit reason parameter will display a reason for not enabling or aborting the DPF service regeneration. Refer to the reasons that are displayed and the corrective action for each reason.

DPF Regeneration Parameters	Unsuccessful Regeneration – Number of Completed Regenerations Did Not Increment By One	Corrective Action For An Unsuccessful Regeneration
DPF Regeneration Inhibit Reason	APP – The APP position sensor indicated over 1 percent	Ensure the accelerator pedal was not applied during the service regeneration. <ul style="list-style-type: none"> If the accelerator pedal was not applied, test the accelerator pedal position (APP) sensor
	BPP Applied – The brake pedal position indicated Applied.	Ensure that the brake pedal was not applied during the service regeneration procedure. <ul style="list-style-type: none"> If the brake pedal was not applied, test the brake pedal switch
	Important: The scan tool must remain connected to the data communication link (DCL) during the entire service regeneration procedure. Device Control – The scan tool has interrupted service regeneration. A loss of communication between the scan tool and the vehicle has occurred.	<ul style="list-style-type: none"> The scan tool Exit or OFF soft key button was depressed Inspect for a poor connection at DCL Ignition OFF for 90 seconds, the DPF temperature must be less than 752° F (400° C). Restart the service regeneration.

Service Regeneration Unsuccessful (cont'd)

DPF Regeneration Parameters	Unsuccessful Regeneration – Number of Completed Regenerations Did Not Increment By One	Corrective Action For An Unsuccessful Regeneration
DPF Regeneration Inhibit Reason	DPF Temperature – DPF service regeneration temperatures are less than a calibrated threshold.	<ul style="list-style-type: none"> Observe the DTC information. Test for a degraded diesel oxidation catalyst (DOC) Test for a skewed exhaust temperature sensor, EGT sensor 1.
	EGT 1 High – EGT sensor 1 temperature range was greater than a calibrated threshold for greater than 1 second.	Replace the DPF and perform the DPF Reset or For Replace The DPF with a scan tool.
	EGT 2 High – EGT sensor 2 temperature range was greater than a calibrated threshold for greater than 1 second.	Replace the DPF and perform the DPF Reset or For Replace The DPF with a scan tool.
	Ignition Voltage – Battery voltage was less than 10 volts.	Test the battery and charging system for proper operation.
	None	Refer to the DPF Regeneration Status parameter
	Not In Park – Transmission gear selector is not in Park	Ensure that the transmission gear selector remained in Park during the Service Regeneration procedure. <ul style="list-style-type: none"> If the gear selector remained in the Park position, test the transmission range switch and circuits.
DPF Regeneration Status	Required or Active	The DPF may be excessively restricted. Replace the DPF and perform the DPF Reset For Replace the DPF with a scan tool.

(continued on next page)

Diesel Particulate Filter (DPF) – Service Regeneration (cont'd)

Caution:

Tailpipe outlet exhaust temperature will be greater than 300°C (572°F) during service regeneration. To help prevent personal injury or property damage from fire or burns, perform the following:

1. Do not connect any shop exhaust removal hoses to the vehicle's tailpipe.
2. Park the vehicle outdoors and keep people, other vehicles, and combustible material away during service regeneration.
3. Do not leave the vehicle unattended.

Caution:

To avoid extremely elevated exhaust temperatures, inspect and remove any debris or mud build up at the exhaust cooler located at the tailpipe.

Notice:

Due to the elevated engine temperatures created while performing this procedure it is imperative to keep the front of vehicle in an open environment, with the hood open, away from any walls or buildings. This will ensure proper airflow across the radiator.

Important:

If you were not referred to this document from another diagnostic, DO NOT perform this procedure.

CONDITIONS FOR RUNNING

The following conditions must be met in order to enable DPF Service Regeneration:

Important: Do not refuel the vehicle during DPF Service Regeneration.

- DTCs P2463 or P244B are the only active DTCs displayed.
- The battery voltage is greater than 10 volts.
- The engine speed is between 600-1,250 RPM.
- The exhaust gas temperature (EGT) sensors 1 and 2 are less than 400°C (752°F).
- The engine coolant temperature (ECT) sensor 1 is between 70-115°C (158-239°F).
- The brake pedal and accelerator pedal are in the released position.
- The transmission is in Park or Neutral.

(continued on next page)

Diesel Particulate Filter (DPF) – Service Regeneration (cont'd)

TEST PROCEDURE

1. Clear all DTCs with a scan tool before proceeding with DPF Service Regeneration.
2. Observe the scan tool DPF Regenerations Completed parameter and record the value.
3. Check the following fluid levels before and after this procedure:
 - Engine oil
 - Engine coolant
 - Power steering
 - Transmission
 - Fuel level should be over 15 percent to ensure a successful regeneration.
8. Park the vehicle outside the facility, away from any obstacles, place the transmission in Park and apply the parking brake.
9. Ensure the hood is open.
10. Select DPF Service Regeneration in the Output Controls menu and follow the instruction on the scan tool.
11. Command the DPF Service Regeneration ON with a scan tool. If the service regeneration failed to start, repair the vehicle for the condition indicated by the scan tool DPF Regen Inhibit Reason parameter. Refer to the Service Regeneration Unsuccessful table.
12. The DPF Service Regeneration will take approximately 35 minutes consisting of the following:
 - 8.1. 8 minutes for the exhaust system to warm up, with the engine speed slowly increasing to 1,600 RPM, then 2,200 RPM and finally 2,500 RPM
 - 8.2. 20 minutes for the DPF to regenerate at an engine speed between 2,200-2,500 RPM
 - 8.3. 3 minutes for the exhaust system to cool down with the engine speed will slowly returning to 1,400 RPM
 - 8.4. 3 minutes at 800 RPM, then idle speed of 680 RPM
16. The DPF Service Regeneration will be terminated if any of the following actions are performed:
 - Applying the brake pedal
 - Applying the accelerator pedal
 - Selecting Drive or Reverse
 - Commanding DPF Service Regeneration OFF using the scan tool or disconnecting the scan tool from the vehicle
20. **Important:**
 - The DPF Service Regeneration will terminate if the DPF or ECT temperatures exceed a calibrated threshold.
 - Temporary blue, gray, or white smoke during this procedure may be an indication of a fuel with high sulfur content.
22. After the service regeneration completes, clear all DTCs and turn the ignition OFF for 90 seconds. If the service regeneration did not complete or aborted, replace the Exhaust Particulate Filter.
23. Engine running, perform the following within 10 minutes of a successful service regeneration. Operate the vehicle within the following Conditions for Running DTC P2002. Refer to DTC P2002 . If DTC P2002 sets, replace the Exhaust Particulate Filter.
24. Verify that the scan tool DPF Regenerations Completed parameter has increased by one. If the value has not increased by one, refer to Service Regeneration Unsuccessful.

Diesel Particulate Filter (DPF) – Service Bulletin #DTC P2459



Diesel Particulate Filter DTC P2459

Models: 2007-2008 Chevrolet Express, Kodiak, Silverado
2007-2008 GMC Savana, Sierra, Topkick
Equipped with the 6.6L diesel engine RPO code LMM

CONDITION/CONCERN:

A dealer may encounter a 2007-2008 6.6 Duramax Diesel Engine setting DTC P2459 for Diesel Particulate Filter Regeneration Too Often. P2459 may occur more often on vehicles that tow heavy loads on a regular basis.

RECOMMENDATION/INSTRUCTIONS:

Complete the current SI diagnostics for any trouble code or symptom found. Completion of the P2459 diagnostic is imperative.

Air Charge Cooler leaks, Intake air box/air filter modifications, poor fuel quality, or any basic engine driveability concern that causes excessive smoke may induce a P2459 to set.

If diagnostics are inconclusive there has been a new calibration released for P2459.

Install the latest TIS2000 calibration for P2459 and evaluate repairs.

Please follow this diagnostic or repair process thoroughly and complete each step. If the condition exhibited is resolved without completing every step, the remaining steps do not need to be performed.

Engine Controls - DPF Exhaust Pressure Differential Sensor (LMM)

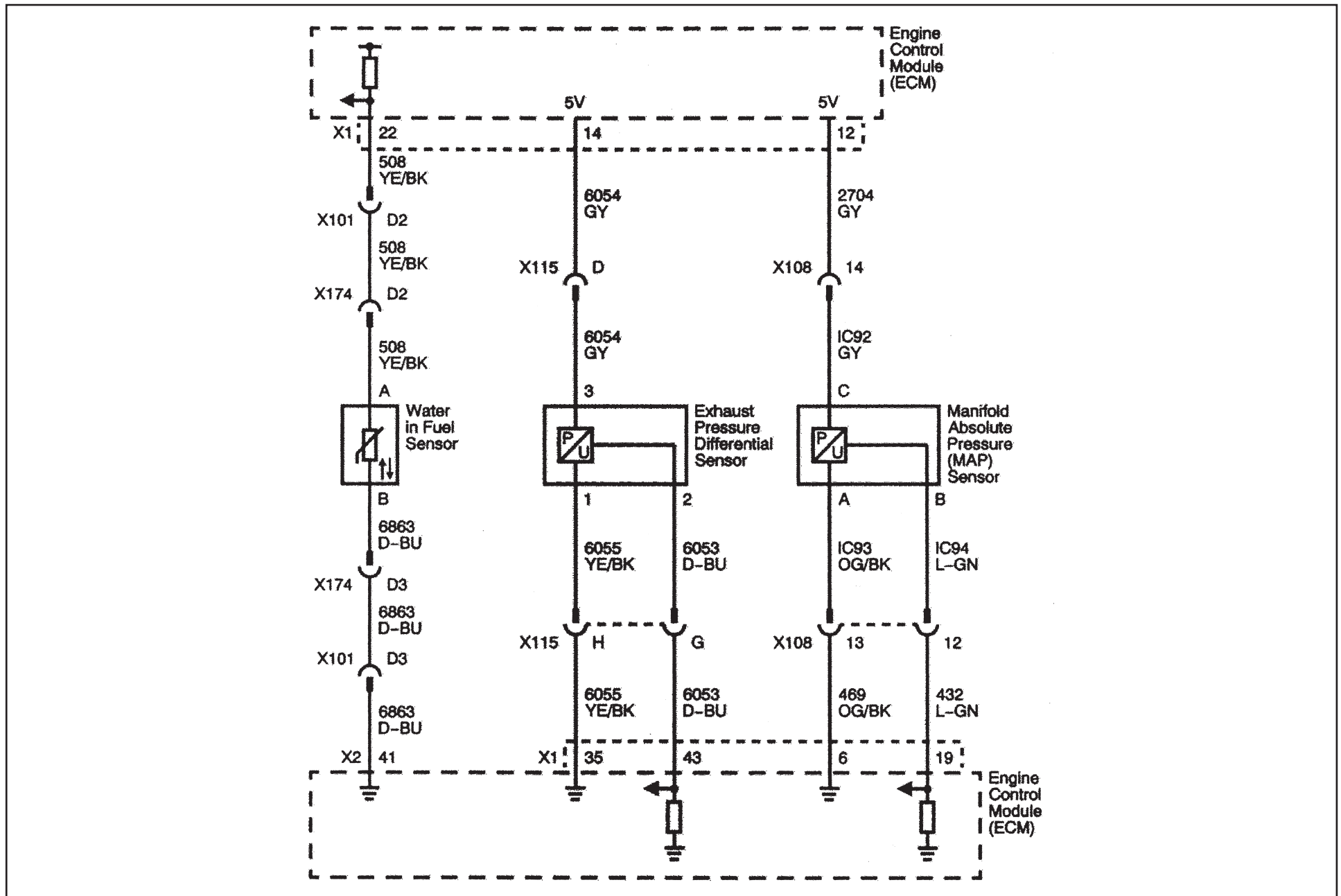

Engine Controls - Exhaust Temperature Sensors (LMM)

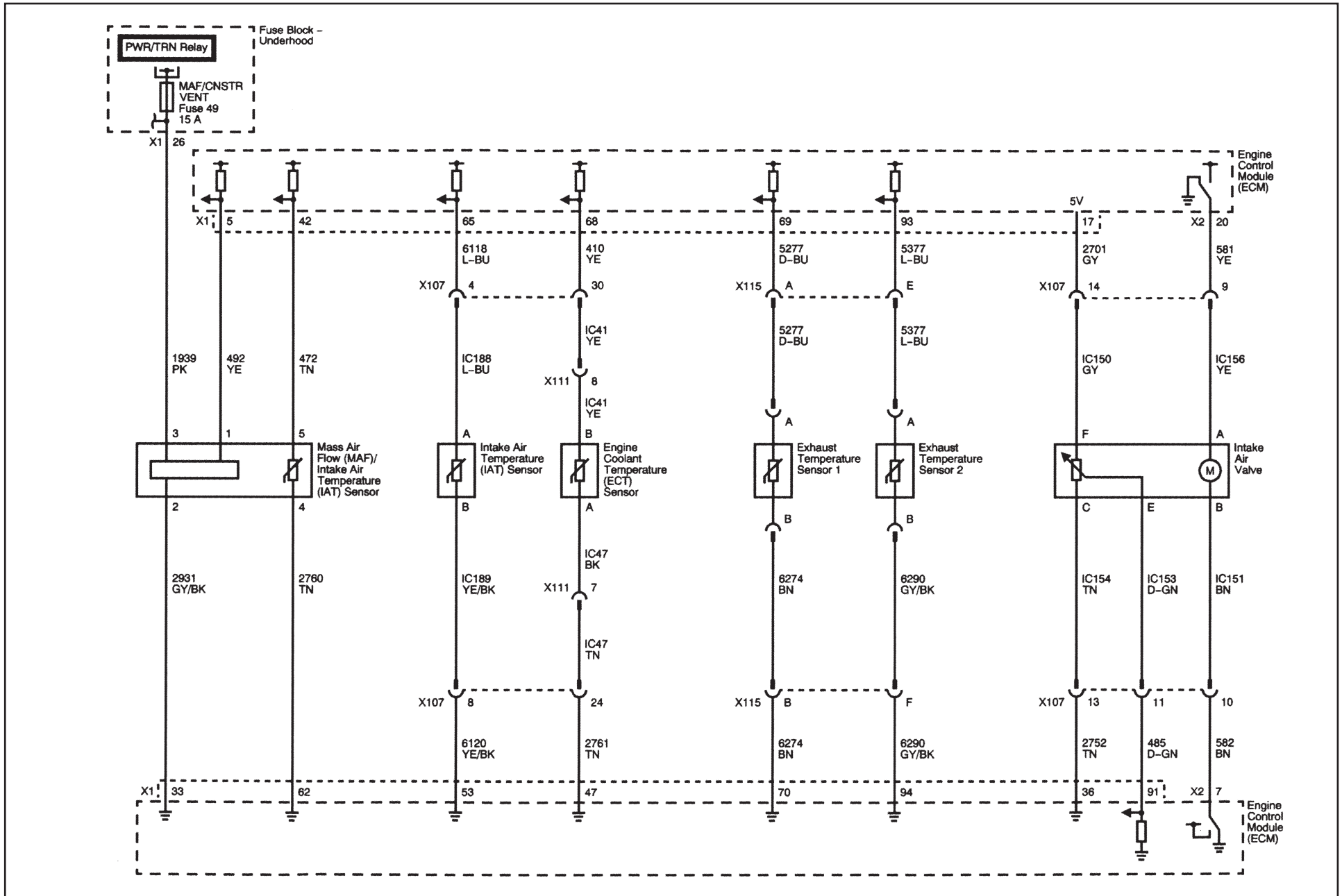

Section B – Components – Locations and Pinouts – Body Control Module (BCM) – Location View

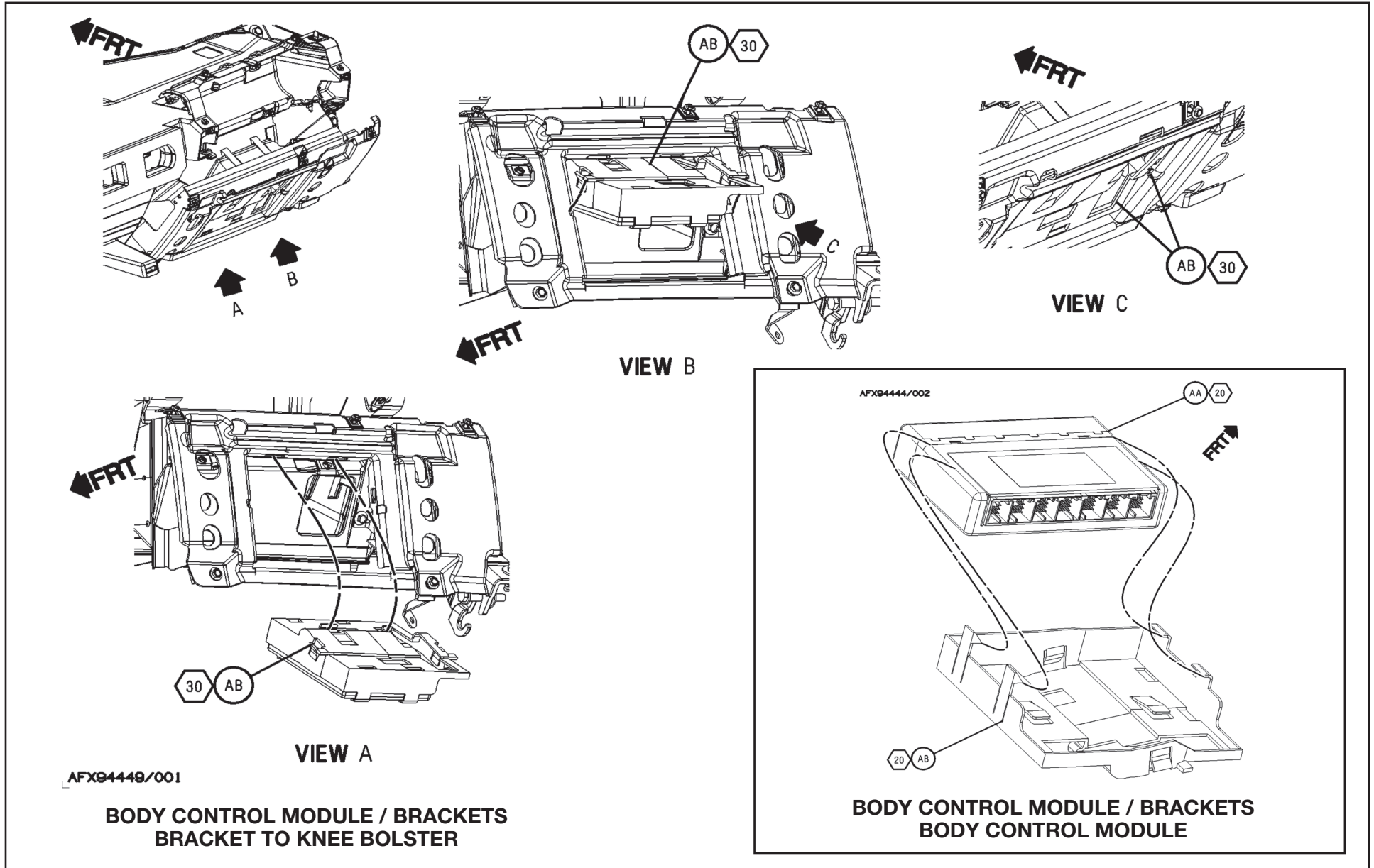

Body Control Module (BCM) X1

Connector Part Information

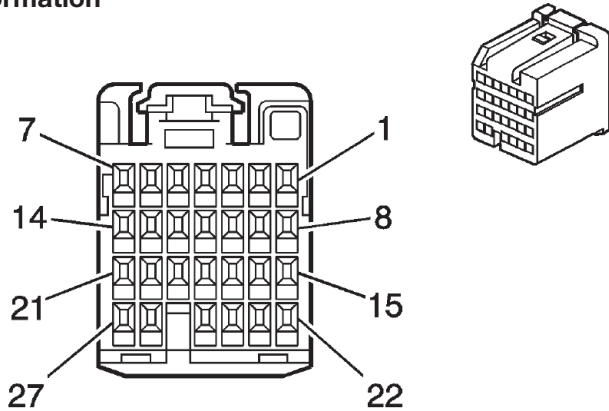

OEM: 15482789

Service: See Catalog

Description: 27-Way F
HIT Series (L-GN)

Terminal Part Information

Pins: 2-6, 8, 9, 14-21, 23-26

Terminal/Tray: SNAC3-A021T-MO.64/20

Core/Insulation Crimp: J/J

Release Tool/Test Probe: 15315247/J-35616-64B (L-BU)

Pin	Wire Color	Circuit No.	Function
10-13	--	--	Not Used
14	0.35 PK	3	Ignition Voltage
15	0.35 D-GN	663	Hazard Switch Left Turn Signal
16	0.35 TN	664	Hazard Switch Right Turn Signal
17	0.35 PK	1444	12-Volt Reference
18	0.35 YE	525	Headlamp Dimmer Switch Low Beam Signal
19	0.35 WH	111	Theft Deterrent Alarm Enable Signal
20	--	--	Not Used
21	0.35 BN	4	Ignition Voltage
22	--	--	Not Used
23	0.35 L-BU	1788	Tow/Haul Switch Signal
24	0.35 PK	94	Windshield Washer Switch Signal
25	0.35 YE	307	Headlamp Switch Flash to Pass Signal
26	0.5 TN/WH	816	A/T Shift Lock Solenoid Control
27	--	--	Not Used

Pin	Wire Color	Circuit No.	Function
1	--	--	Not Used
2	0.35 PK	1020	Ignition Voltage
3	0.35 GY	1884	Cruise Control Switch Signal
4	0.35 WH	530	Ignition Voltage
5	0.35 L-GN	1715	Windshield Wiper Switch High Signal
6	0.35 L-GN	6818	Steering Wheel Control Signal
7	--	--	Not Used
8	0.35 TN/BK	6009	Low Reference
9	0.35 L-BU	1714	Windshield Wiper Switch Low Signal

Body Control Module (BCM) X2

Connector Part Information

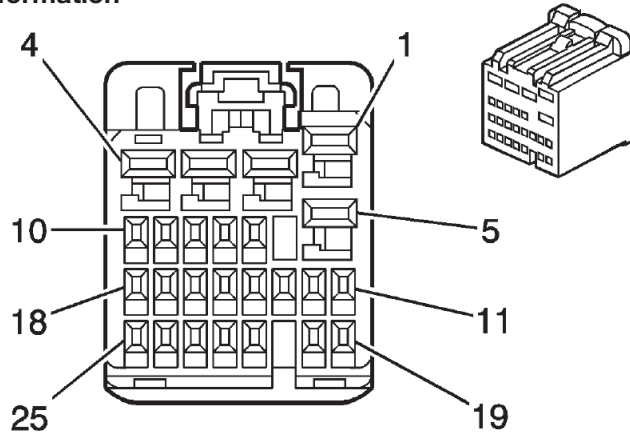

OEM: 15482790

Service: See Catalog

Description: 25-Way F
HIT Series (NA)

Terminal Part Information

Pins: 1, 2, 3, 5

Terminal/Tray: SNAC3-A061T-M2.8/20

Core/Insulation Crimp: E/A

Release Tool/Test Probe: 15315247/J-35616-4A (PU)

Pins: 8, 11, 12, 17, 18, 21, 22, 25

Terminal/Tray: SNAC3-A021T-M0.64/20

Core/Insulation Crimp: J/J

Release Tool/Test Probe: 15315247/J-35616-64B (L-BU)

Pin	Wire Color	Circuit No.	Function
5	0.5 GY/BK	690	Courtesy Lamp Control (YF7)
	0.8 D-BU/WH	149	Courtesy Lamp Control (without YF7)
6-7	--	--	Not Used
8	0.35 L-BU	13	Headlamp Switch Park Lamps Signal
9-10	--	--	Not Used
11	0.35 WH	278	Ambient Light Sensor Signal
12	0.35 WH	103	Headlamp Switch Headlamps On Signal
13-16	--	--	Not Used
17	0.35 D-GN	306	Headlamp Switch Headlamps Off Signal
18	0.35 D-BU/WH	149	Courtesy Lamp Control
19-20	--	--	Not Used
21	0.5 D-BU	6727	Traction Control Preference Switch Signal (JL4)
22	0.35 D-BU	38	Backup Lamp Relay Control
23-24	--	--	Not Used
25	0.35 PU	328	Interior Lamp Defeat Switch Signal

Pin	Wire Color	Circuit No.	Function
1	0.8 OG	1732	Courtesy Lamps Control
2	0.5 RD/WH	2540	Battery Positive Voltage
3	0.5 BN/WH	230	Instrument Panel Lamps Dimming Control
4	--	--	Not Used

Body Control Module (BCM) X3

Connector Part Information

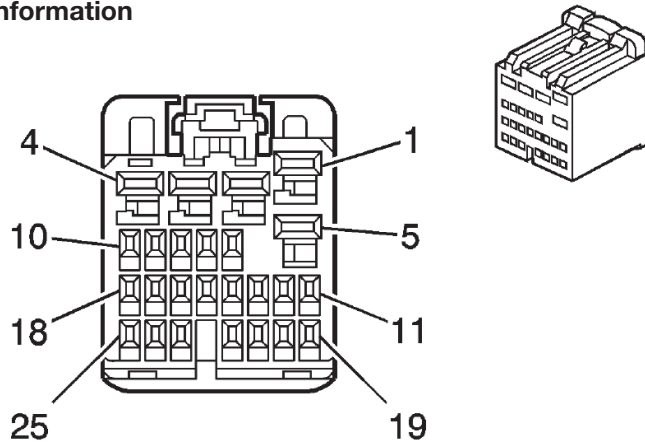

OEM: 15482790

Service: See Catalog

Description: 25-Way F
HIT Series (NA)

Terminal Part Information

Pins: 1, 2, 3, 5

Terminal/Tray: SNAC3-A061T-M2.8/20

Core/Insulation Crimp: E/A

Release Tool/Test Probe: 15315247/J-35616-4A (PU)

Pins: 8, 11, 12, 17, 18, 21, 22, 25

Terminal/Tray: SNAC3-A021T-M0.64/20

Core/Insulation Crimp: J/J

Release Tool/Test Probe: 15315247/J-35616-64B (L-BU)

Pin	Wire Color	Circuit No.	Function
8	0.5 TN/BK	2500	High Speed GMLAN Serial Data Bus (+)
9	0.5 TN	2501	High Speed GMLAN Serial Data Bus (-)
10	0.35 D-GN	5060	Low Speed GMLAN Serial Data
11	0.35 D-GN	44	Instrument Panel Lamps Dimmer Switch Signal
12	0.35 OG/WH	812	IP Dimming Voltage Reference
13	0.35 PU	7062	Brake Switch Signal
14-15	--	--	Not Used
16	0.5 TN/BK	2500	High Speed GMLAN Serial Data Bus (+)
17	0.5 TN	2501	High Speed GMLAN Serial Data Bus (-)
18	0.35 YE	6817	LED Backlight Dimming Control
19	0.5 L-BU	5986	Serial Data Communication Enable
20-21	--	--	Not Used
22	0.35 D-GN/WH	7158	Cruise Control Indicator Dimming Signal
23-25	--	--	Not Used

Pin	Wire Color	Circuit No.	Function
1	0.8 BK/WH	351	Ground
2	0.8 RD/WH	2140	Battery Positive Ground
3	0.5 RD/WH	3840	Battery Positive Ground
4	--	--	Not Used
5	0.8 BK/WH	351	Ground
6-7	--	--	Not Used

Body Control Module (BCM) X4

Connector Part Information

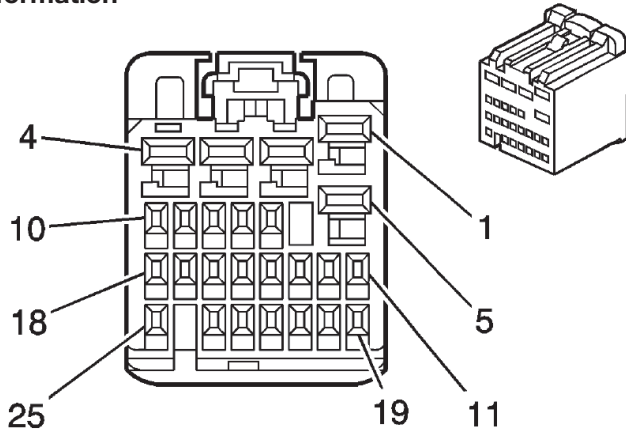

OEM: 15482792

Service: See Catalog

Description: 25-Way F
HIT Series (BK)

Terminal Part Information

Pins: 6, 7, 11-13, 15-17, 19-21, 23, 24

Terminal/Tray: SNAC3-A021T-M0.64/20

Core/Insulation Crimp: J/J

Release Tool/Test Probe: 15315247/J-35616-64B (L-BU)

Pins: 1-5

Terminal/Tray: SNAC3-A061T-M2.8/20

Core/Insulation Crimp: E/A

Release Tool/Test Probe: 15315247/J-35616-4A (PU)

Pin	Wire Color	Circuit No.	Function
6	0.35 D-GN	6134	Local Interconnect Network 3
7	0.35 YE	196	Windshield Wiper Motor Park Switch Signal
8-11	--	--	Not Used
12	0.35 YE	5187	Right Trailer Turn Signal Lamp (UY7)
13	0.35 OG	5186	Left Trailer Turn Signal Lamp (UY7)
14	--	--	Not Used
15	0.35 OG	2268	Windshield Washer Relay Control
16	0.35 TN/WH	1969	Headlamp High Beam Relay Control
17-18	--	--	Not Used
19	0.5 D-BU	5986	Accessory Wakeup Serial Data
20	--	--	Not Used
21	0.35 YE	5199	Run/Crank Relay Coil Control
22	--	--	Not Used
23	0.35 PU	544	Headlamp Low Beam Control
24-25	--	--	Not Used

Pin	Wire Color	Circuit No.	Function
1	0.8 RD/WH	2740	Battery Positive Voltage
2	0.8 RD/WH	3040	Battery Positive Voltage
3	0.8 RD/WH	2940	Battery Positive Voltage
4	0.8 RD/WH	2240	Battery Positive Voltage
5	0.8 D-BU/WH	1315	Right Front Turn Signal Lamp Control

Body Control Module (BCM) X5

Connector Part Information

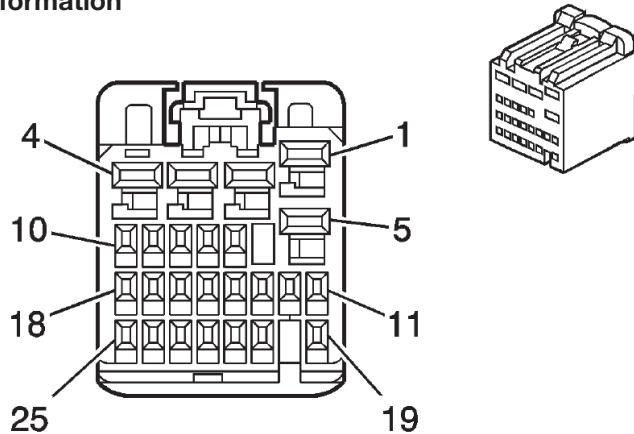

OEM: 15480179

Service: See Catalog

Description: 25-Way F
HIT Series (BN)

Terminal Part Information

Pins: 6, 11, 13, 15, 16, 18-21, 23, 24

Terminal/Tray: SNAC3-A021T-M0.64/20

Core/Insulation Crimp: J/J

Release Tool/Test Probe: 15315247/J-35616-64B (L-BU)

Pins: 1, 2, 4, 5

Terminal/Tray: SNAC3-A061T-M2.8/20

Core/Insulation Crimp: Pins 1, 2 - C/A

Core/Insulation Crimp: Pins 4, 5 - E/A

Release Tool/Test Probe: 15315247/J-35616-4A (PU)

Pin	Wire Color	Circuit No.	Function
4	0.8 L-BU/WH	1314	Left Front Turn Signal Lamp Control
5	0.5 WH	5065	Stop Lamps Control
6	0.35 L-BU/WH	6311	Torque Converter Clutch (TCC) Brake Signal
7-10	--	--	Not Used
11	0.35 YE	43	Ignition Voltage
12	--	--	Not Used
13	0.35 OG	300	Ignition Voltage
14-15	--	--	Not Used
16	0.35 L-BU	1134	Park Brake Switch Signal
17	--	--	Not Used
18	0.35 TN	28	Horn Relay Control
19	--	--	Not Used
20	0.35 GY	91	Windshield Wiper Switch Signal 2
21	0.35 TN	860	Front Windshield Wiper Switch High Signal
22	--	--	Not Used
23	0.35 PK/WH	1970	Headlamp Low Beam Relay Control
24	0.35 D-BU	45	Park Lamp Control
25	--	--	Not Used

Pin	Wire Color	Circuit No.	Function
1	1 YE	618	Left Rear Turn Signal Lamp Control
2	1 D-GN	619	Right Rear Turn Signal Lamp Control
3	--	--	Not Used

Body Control Module (BCM) X6

Connector Part Information

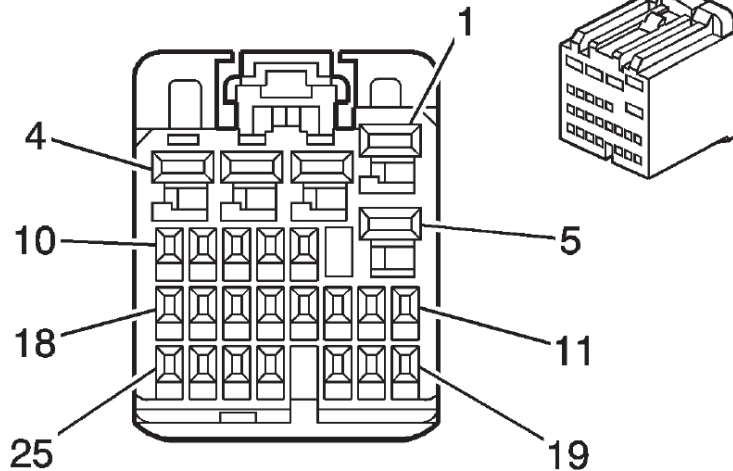

OEM: 15482793

Service: See Catalog

Description: 25-Way F
HIT Series (PK)

Terminal Part Information

Pins: 2

Terminal/Tray: SNAC3-A061T-M2.8/20

Core/Insulation Crimp: E/A

Release Tool/Test Probe: 15315247/J-35616-4A (PU)

Pins: 8-10, 12, 14-16, 18, 22

Terminal/Tray: SNAC3-A021T-M0.64/20

Core/Insulation Crimp: J/J

Release Tool/Test Probe: 15315247/J-35616-64B (L-BU)

Pin	Wire Color	Circuit No.	Function
9	0.35 D-BU	245	Passenger Door Lock Switch Unlock Control (AU3)
10	0.35 GY/BK	745	Left Front Door Ajar Switch Signal
11	--	--	Not Used
12	0.35 PK/BK	1303	Liftgate Ajar Switch Signal (Passenger/Cargo)
13	--	--	Not Used
14	0.35 YE/BK	1181	Right Rear Door Open Switch Signal (Passenger/Cargo)
15	0.35 D-BU/ WH	1179	Left Rear Door Open Switch Signal (D26)
16	0.35 L-GN	1177	Right Front Door Open Switch Signal
17	--	--	Not Used
18	0.35 L-BU	244	Passenger Door Lock Switch Lock Control (AU3)
19-21	--	--	Not Used
22	0.35 L-GN	5926	Rear Access Open Switch Signal (Passenger/Cargo)
23-25	--	--	Not Used

Pin	Wire Color	Circuit No.	Function
1	--	--	Not Used
2	0.8 L-BU	1320	CHMSL Control (Passenger/Cargo)
3-7	--	--	Not Used
8	0.35 TN/WH	746	Right Front Door Ajar Switch Signal

Body Control Module (BCM) X7

Connector Part Information

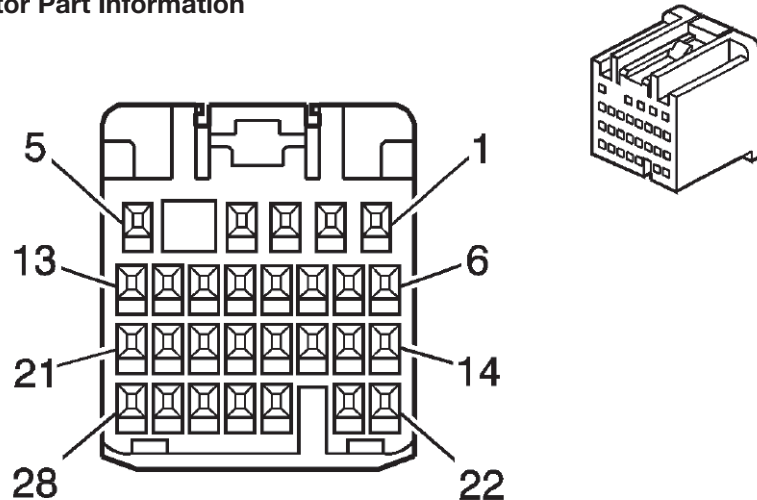

OEM: 15466053

Service: See Catalog

Description: 28-Way F
HIT Series (GY)

Terminal Part Information

Pins: 2, 6, 7, 9, 11, 12, 23, 24

Terminal/Tray: SNAC3-A021T-M0.64/20

Core/Insulation Crimp: J/J

Release Tool/Test Probe: 15315247/J-35616-64B (L-BU)

Pin	Wire Color	Circuit No.	Function
8	--	--	Not Used
9	0.5 L-BU	244	Passenger Door Lock Switch Lock Control (AU3 without PRP)
10	--	--	Not Used
11	0.5 OG/BK	781	Driver Door Lock Switch Unlock Signal (AU3)
12	0.5 PK/BK	780	Driver Door Lock Switch Lock Signal (AU3)
13-22	--	--	Not Used
23	0.5 TN	126	Left Front Door open Switch Signal
24	0.5 L-GN	66	A/C Request Signal (C60)
25-28	--	--	Not Used

Pin	Wire Color	Circuit No.	Function
1	--	--	Not Used
2	0.5 YE	356	Driver Door Lock Relay Unlock Control (Passenger/Cargo with AU3)
3-5	--	--	Not Used
6	0.5 YE	356	Driver Door Lock Relay Unlock Control (AU3)
7	0.5 L-BU	244	Passenger Door Lock Switch Lock Control (AU3)

Body Control Module – Calibrations for Lighting – Special Equipment Option (SEO)

Application	Model	Options	BCM Calibration Part Number
* LED Tail Lamps * No 60 Minute Dome Lamps * No Permanent Dome Lamps * No Canada	3500 Cutaways	&8H9-Z49/5D3/5H2	25852586
* USA * 42.5 Minute Dome Lamps * LED Tail Lamps	3500 Cutaways	&5D3&8H9	25852588
* USA * Indefinite Dome Lamps * LED Tail Lamps	3500 Cutaways	&5H2&8H9	25852589
* Back-Up Alarm * No Canada	1500 / 2500 / 3500 Cargo	&8S3-Z49	25852590
* LED Tail Lamps * Canada	3500 Cutaways	&8H9&Z49-5D3/5H2	25852587
* Back-Up Alarm	1500 / 2500 / 3500 Cargo	&8S3-Z49	25852591

All Engines – Engine Control Module (ECM) – Location

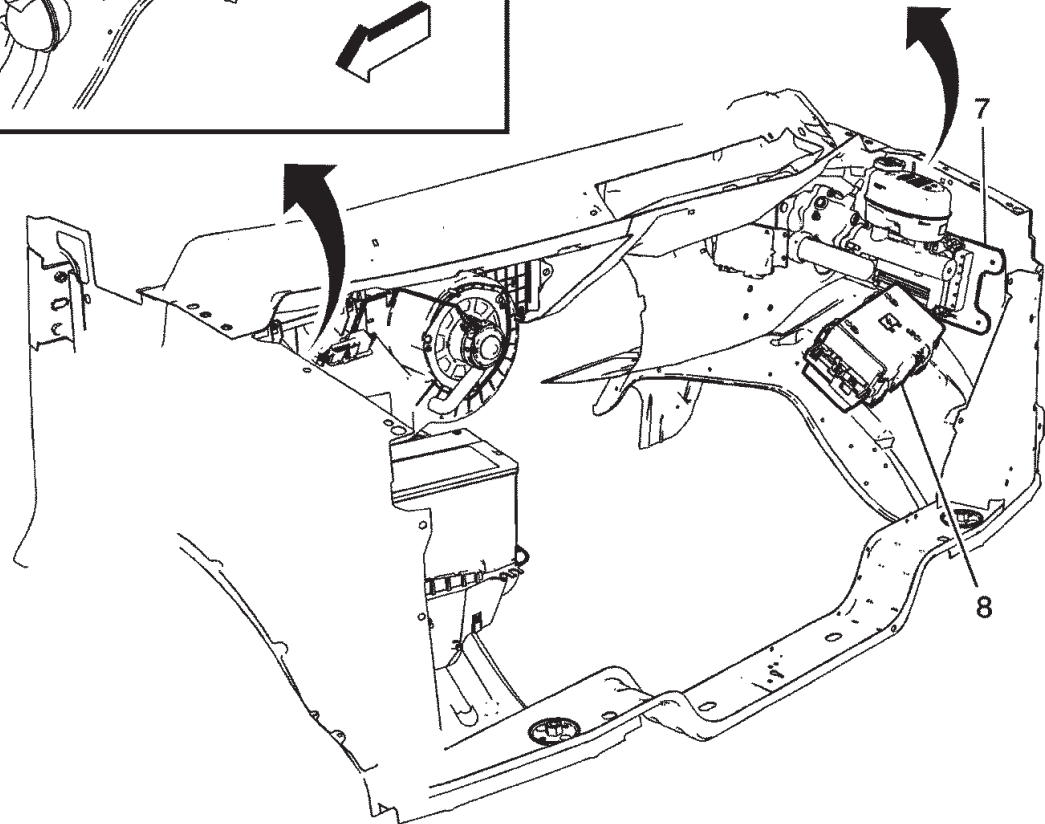
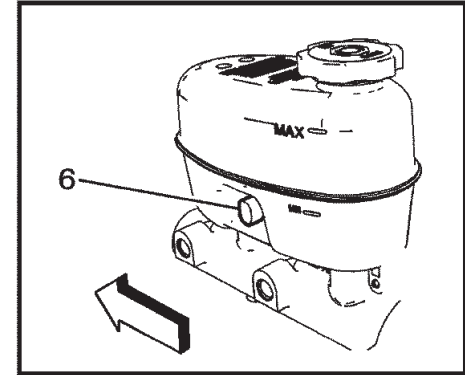
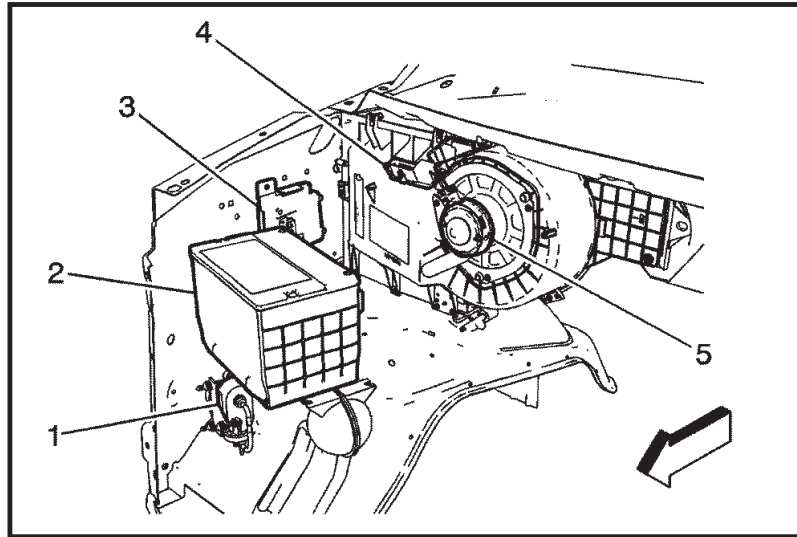

- (1) Vacuum Pump (6.6L)
- (2) Battery
- (3) Transmission Control Module (TCM)
- (4) Blower Motor Resistor Assembly
- (5) Blower Motor
- (6) Brake Fluid Level Switch
(Heavy Duty)
- (7) Engine Control Module (ECM)
- (8) Fuse Block - Underhood

4.3L (LU3) - Engine Control Module (ECM) - Connector X1

Pin	Wire Color	Circuit No.	Function
1	0.35 D-BU	1161	Accelerator Pedal Position (APP) Sensor 1 Signal
2	0.8 PU	1670	Heated Oxygen Sensor (HO2S) High Signal - Bank 2 Sensor 2
3	0.5 D-BU	5985	Accessory Wakeup Serial Data
4-5	--	--	Not Used
6	0.35 D-GN/WH	465	Fuel Pump Relay Control - Primary
7	--	--	Not Used
8	0.35 TN	5514	Low Reference (C60)
9	0.8 TN/WH	1669	Heated Oxygen Sensor (HO2S) Low Signal - Bank 1 Sensor 2
10	0.8 TN	1671	Heated Oxygen Sensor (HO2S) Low Signal - Bank 2 Sensor 2
11-12	--	--	Not Used
13	0.5 YE	5991	Powertrain Relay Control
14	--	--	Not Used
15	0.8 GY/WH	3122	Heated Oxygen Sensor (HO2S) Low Control - Bank 1 Sensor 2
16	0.8 OG/WH	3223	Heated Oxygen Sensor (HO2S) Low Control - Bank 2 Sensor 2
17	0.8 PU/WH	1668	Heated Oxygen Sensor (HO2S) High Signal - Bank 1 Sensor 2
18	0.35 L-BU	1162	Accelerator Pedal Position (APP) Sensor 2 Signal
19	0.5 PK	439	Ignition Voltage
20	0.5	440	Battery Positive Voltage
21	0.35 PU	1272	Low Reference
22-23	--	--	Not Used
24	0.5 TN	2759	Low Reference

Pin	Wire Color	Circuit No.	Function
25	0.35 OG/BK	380	A/C Refrigerant Pressure Sensor Signal (C60)
26	--	--	Not Used
27	0.35 BN/WH	419	MIL Control
28-29	--	--	Not Used
30	0.35 D-GN/WH	459	A/C Compressor Clutch Relay Control (C60)
31	--	--	Not Used
32	0.35 YE/BK	625	Starter Enable Relay Control
33-34	--	--	Not Used
35	0.5 TN	470	Low Reference
36	--	--	Not Used
37	0.5 YE	492	Mass Air Flow (MAF) Sensor Signal
38	--	--	Not Used
39	0.5 PU	1589	Fuel Level Sensor Signal - Primary
40	--	--	Not Used
41	0.35 BN	1271	Low Reference
42	0.5 D-GN	890	Fuel Tank Pressure Sensor Signal
43	0.5 TN/BK	2500	High Speed GMLAN Serial Data Bus (+)
44	0.5 TN	2501	High Speed GMLAN Serial Data Bus (-)
45-46	--	--	Not Used
47	0.35 WH/BK	1164	5-Volt Reference 2
48-49	--	--	Not Used
50	0.35 YE/BK	1827	Vehicle Speed Signal

4.3L (LU3) – Engine Control Module (ECM) – Connector X1 (cont'd)

Pin	Wire Color	Circuit No.	Function
51-53	--	--	Not Used
54	0.5 OG/BK	6399	Replicated TOS Signal
55	0.5 L-BU/WH	6311	Torque Converter Clutch (TCC) Brake Signal
56	--	--	Not Used
57	0.35 OG/BK	1786	Ignition Lock Cylinder Control Actuator Signal
58	0.5 TN	472	Intake Air Temperature (IAT) Sensor Signal

Pin	Wire Color	Circuit No.	Function
59-64	--	--	Not Used
65	0.35 GY	2700	5-Volt Reference 1 (C60)
66	0.5 GY	2709	5-Volt Reference 1
67	0.35 TN	1274	5-Volt Reference 1
68-69	--	--	Not Used
70	0.5 WH	1310	Evaporative Emission (EVAP) Canister Vent Solenoid Control
71-72	--	--	Not Used
73	0.5 PK	1339	Ignition Voltage

4.3L (LU3) – Engine Control Module (ECM) – Connector X2

Connector Part Information

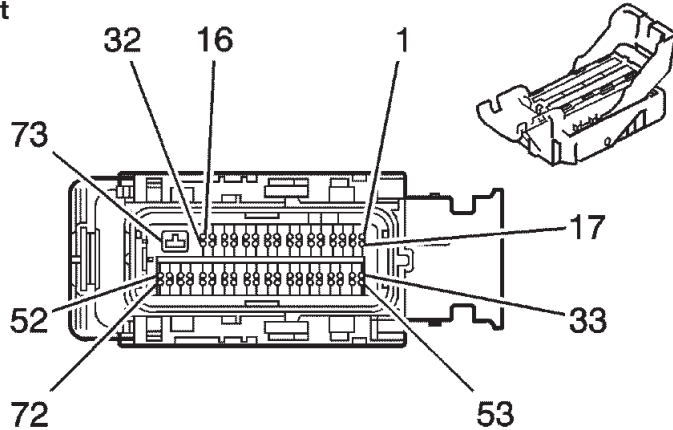

OEM: 15497996

Service: 88988372

Description: 73-Way F 0.64
2.8 Series Sealed (BK)

Terminal Part Information

Pins: 73

Terminal/Tray: 7116-4152-02/9

Core/Insulation Crimp: A/5

Release Tool/Test Probe: 12094430/J-35616-35 (VT)

Pins: 5, 20, 33, 35, 36, 40, 41, 45, 46, 53, 54, 57, 59

Terminal/Tray: 33467-0003/23

Core/Insulation Crimp: H/H

Release Tool/Test Probe: J-38125-213/J-35616-64B (L-BU)

Pins: 4, 6-13, 16, 22-24, 30-32, 39, 43, 49, 50, 51, 58, 70, 71, 37, 38, 48, 65, 66, 68

Terminal/Tray: 33467-0005/23

Core/insulation Crimp: Pins 4, 6-13, 16, 22-24, 30-32, 39, 43, 49-51, 58, 70, 71-J/J

Core Insulation Crimp: Pins 37, 38, 48, 65, 66, 68 - K/K

Release Tool/Test Probe: J-38125-213/J-35616-64B (L-BU)

Pin	Wire Color	Circuit No.	Function
1-3	--	--	Not Used
4	0.5 TN	2761	Low Reference
5	0.35 GY/BK	6272	Low Reference
6	0.5 TN	1744	Fuel Injector 1 Control
7	0.5 YE/BK	846	Fuel Injector 6 Control
8	0.5 TN/WH	845	Fuel Injector 5 Control
9	0.5 BN	2129	Low Reference
10	0.5 L-BU/BK	844	Fuel Injector 4 Control
11	0.5 PK/BK	1746	Fuel injector 3 Control
12	0.5 L-GN/BK	1745	Fuel Injector 2 Control
13	0.5 GY	2704	5-Volt Reference 1
14-15	--	--	Not Used
16	0.5 YE	581	Throttle Actuator Control Motor Control - 1
17-19	--	--	Not Used
20	0.35 BN	6266	Low Reference
21	--	--	Not Used
22	0.5 PU	2121	Ignition Coil 1 Control
23	0.5 L-BU	2123	Ignition Coil 3 Control
24	0.5 OG/WH	2122	Ignition Coil 2 Control
25-29	--	--	Not Used
30	0.5 D-GN/WH	428	Evaporative Emission (EVAP) Canister Purge Solenoid Control
31	0.5 OG	225	Generator Turn On Signal
32	0.5 BN	582	Throttle Actuator Control Motor Control - 2
33	0.35 D-BU	6259	5-Violet Reference 1
34	--	--	Not Used

4.3L (LU3) – Engine Control Module (ECM) – Connector X2 (cont'd)

Pin	Wire Color	Circuit No.	Function
35	0.35 GY	2705	5-Volt Reference 1
36	0.35 TN/WH	331	Oil Pressure Sensor Signal
37	0.8 PU/WH	1665	Heated Oxygen Sensor (HO2S) High Signal - Bank 1 Sensor 1
38	0.8 PU	1666	Heated Oxygen Sensor (HO2S) High Signal - Bank 2 Sensor 1
39	0.5 L-GN	432	Manifold Absolute Pressure (MAP) Sensor Signal
40	0.35 TN	2752	Low Reference
41	0.35 BK	2755	Low Reference
42	--	--	Not Used
43	0.5 GY	23	Generator Field Duty Cycle Signal
44	--	--	Not Used
45	0.35 WH/BK	6271	Crankshaft Position (CKP) Sensor Signal
46	0.35 D-BU/WH	6265	Camshaft Position (CMP) Sensor Signal
47	--	--	Not Used
48	0.8 TN	1664	Heated Oxygen Sensor (HO2S) Low Signal - Bank 1 Sensor 1
49	0.5 OG/BK	469	Low Reference
50	0.5 GY	1716	Knock Sensor (KS) 1 Signal
51	0.5 D-BU	496	Knock Sensor (KS) 1 Signal
52	--	--	Not Used

Pin	Wire Color	Circuit No.	Function
53	0.35 GY	2701	5-Volt Reference 2
54	0.35 PU/WH	6270	5-Volt Reference 2
55-56	--	--	Not Used
57	0.35 D-GN	485	Throttle Position (TP) Sensor 1 Signal
58	0.5 YE	410	Engine Coolant Temperature (ECT) Sensor Signal
59	0.35 PU	486	Throttle Position (TP) Sensor 2 Signal
60-64	--	--	Not Used
65	0.8 GY/WH	3113	Heated Oxygen Sensor (HO2S) Heater Low Control - Bank 1 Sensor 1
66	0.8 L-GN	3212	Heated Oxygen Sensor (HO2S) Heater Low Control - Bank 2 Sensor 1
67	--	--	Not Used
68	0.8 TN	1667	Heated Oxygen Sensor (HO2S) Low Signal - Bank 2 Sensor 1
69	--	--	Not Used
70	0.5 GY	2303	Knock Sensor (KS) 2 Signal
71	0.5 L-BU	1876	Knock Sensor (KS) 2 Signal
72	--	--	Not Used
73	3 BK/WH	1551	Ground

4.8L (LY2) - 5.3L (LMF) - 6.0L (LY6) - Engine Control Module (ECM) - Connector X1

Connector Part Information

OEM: 13580802

Service: See Catalog

Description: 73-Way F MX
123 34566 Series Sealed (BK)

Terminal Part Information

Pins: 73

Terminal/Tray: 7116-4152-02/9

Core/Insulation Crimp: A/5

Release Tool/Test Probe:
12094430/J-35616-35 (VT)

Pins: 1, 12, 13, 23, 29, 30, 32 34, 36, 50, 52 56, 57, 63, 68

Terminal/Tray: 33467-0003/23

Core/Insulation Crimp: H/H

Release Tool/Test Probe: J-38125-213/J-35616-64B (L-BU)

Pins: 9, 16, 18-20, 24, 27, 28, 31, 33, 37, 38, 41, 47, 59, 61,
71, 10, 11, 49, 64, 65, 69

Terminal/Tray: 33467-0005/23

Core/Insulation Crimp: 9, 16, 18-20, 24, 27, 28, 31, 33, 37,
38, 41, 47, 59, 61, 71 - J/J

Core/Insulation Crimp: 10, 11, 49, 64, 65, 69 - K/K

Release Tool/Test Probe: J-38125-213/J-35616-64B (L-BU)

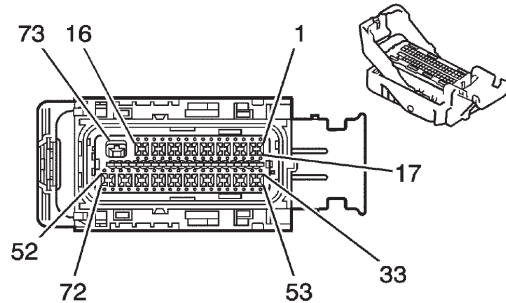

Pin	Wire Color	Circuit No.	Function
1	0.35 OG/BK	1786	Ignition Lock Cylinder Control Actuator Signal
2-8	--	--	Not Used
9	0.5 L-BU/WH	6311	Torque Converter Clutch (TCC) Brake Signal
10	0.8 PU/WH	1668	Heated Oxygen Sensor (HO2S) High Signal - Bank 1 Sensor 2
11	0.8 TN/WH	1669	Heated Oxygen Sensor (HO2S) Low Signal - Bank 1 Sensor 2

Pin	Wire Color	Circuit No.	Function
12	0.35 OG/BK	380	A/C Refrigerant Pressure Sensor Signal (C60)
13	0.35 TN	5514	Low Reference (C60)
14-15	--	--	Not Used
16	0.5 PU	1589	Fuel Level Sensor Signal - Primary
17	--	--	Not Used
18	0.5 D-BU	5985	Accessory Wakeup Serial Data
19	0.5 PK	439	Ignition Voltage
20	0.5 RD/WH	440	Battery Positive Voltage
21-22	--	--	Not Used
23	0.35 PU	1272	Low Reference
24	0.5 D-GN	890	Fuel Tank Pressure Sensor Signal
25-26	--	--	Not Used
27	0.5 TN	2501	High Speed GMLAN Serial Data Bus (-)
28	0.5 TN/BK	2500	High Speed GMLAN Serial Data Bus (+)
29	0.35 D-BU	1161	Accelerator Pedal Position (APP) Sensor 1 Signal
30	0.35 BN	1271	Low Reference
31	0.5 TN	2759	Low Reference
32	0.35 L-BU	1162	Accelerator Pedal Position (APP) Sensor 2 Signal
33	0.5 GY	2709	5-Volt Reference 1
34	0.35 GY	2700	5-Volt Reference 1 (C60)
35	--	--	Not Used
36	0.35 TN	1274	5-Volt Reference 1
37	0.5 TN	472	Intake Air Temperature (IAT) Sensor Signal

4.8L (LY2) – 5.3L (LMF) – 6.0L (LY6) – Engine Control Module (ECM) – Connector X1 (cont'd)

Pin	Wire Color	Circuit No.	Function
38	0.5 TN	470	Low Reference
39-40	--	--	Not Used
41	0.5 YE	492	Mass Air Flow (MAF) Sensor Signal
42-46	--	--	Not Used
47	0.5 PK	1339	Ignition Voltage
48	--	--	Not Used
49	0.8 TN	1671	Heated Oxygen Sensor (HO2S) Low Signal - Bank 2 Sensor 2
50	0.35 D-GN/WH	465	Fuel Pump Relay Control - Primary
51	--	--	Not Used
52	0.35 YE/BK	625	Starter Enable Relay Control
53-55	--	--	Not Used
56	0.35 WH/BK	1164	5-Volt Reference 2
57	0.35 YE/BK	1827	Vehicle Speed Signal
58	--	--	Not Used
59	0.5 YE	5991	Powertrain Relay Control

Pin	Wire Color	Circuit No.	Function
60	--	--	Not Used
61	0.5 WH	1310	Evaporative Emission (EVAP) Canister Vent Solenoid Control
62	--	--	Not Used
63	0.35 D-GN/WH	459	A/C Compressor Clutch Relay Control (C60)
64	0.8 OG/WH	3223	Heated Oxygen Sensor (HO2S) Heater Low Control - Bank 2 Sensor 2
65	0.8 GY/WH	3122	Heated Oxygen Sensor (HO2S) Heater Low Control - Bank 1 Sensor 2
66-67	--	--	Not Used
68	0.35 BN/WH	419	MIL Control
69	0.8 PU	1670	Heated Oxygen Sensor (HO2S) High Signal - Bank 2 Sensor 2
70	--	--	Not Used
71	0.5 OG/BK	6399	Replicated TOS Signal
72	--	--	Not Used
73	3 BK/WH	1551	Ground

4.8L (LY2) - 5.3L (LMF) - 6.0L (LY6) - Engine Control Module (ECM) - Connector X2

Connector Part Information

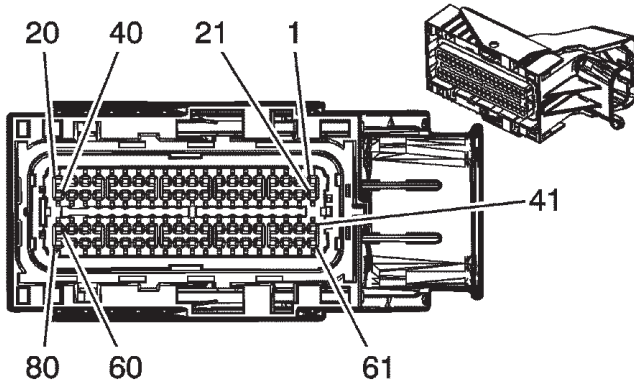

OEM: 13511426

Service: 19115670

Description: 80-Way F
MX123 Series Sealed (GY)

Terminal Part Information

Pins: 2, 3, 34, 35, 41, 43, 44,
50, 53, 58, 63-66, 68, 69

Terminal/Tray: 33467-0003/23

Core/Insulation Crimp: H/H

Release Tool/Test Probe:
J-38125-213/J-35616-64B (L-BU)

Pins: 5, 6, 8, 17-22, 32, 33, 37-40, 61, 12, 13, 16, 26, 27, 29, 30, 52, 56,
57, 59, 60, 70-79

Terminal/Tray: 33467-0005/23

Core/Insulation Crimp: Pins 5, 6, 8, 17-22, 32, 33, 37-40, 61 - J/J

Core/Insulation Crimp: 12, 13, 16, 26, 27, 29, 30, 52, 56, 57, 59,
60, 70-79 - K/K

Release Tool/Test Probe: J-38125-213/J-35616-64B (L-BU)

Pin	Wire Color	Circuit No.	Function
1	--	--	Not Used
2	0.35 PU/WH	6270	5-Volt Reference 2
3	0.35 GY	2701	5-Volt Reference 2
4	--	--	Not Used

Pin	Wire Color	Circuit No.	Function
5	0.5 BN	582	Throttle Actuator Control Motor Control - 2
6	0.5 YE	581	Throttle Actuator Control Motor Control - 1
7	--	--	Not Used
8	0.5 D-GN/WH	428	Evaporative Emission (EVAP) Canister Purge Solenoid Control
9-11	--	--	Not Used
12	0.8 GY/WH	3113	Heated Oxygen Sensor (HO2S) Heater Low Control - Bank 1 Sensor 1
13	0.8 L-GN	3212	Heated Oxygen Sensor (HO2S) Heater Low Control - Bank 2 Sensor 1
14-15	--	--	Not Used
16	0.8 PU	5284	Camshaft Phaser Intake Solenoid (1) (LY6)
17	0.5 D-BU/WH	878	Fuel Injector 8 Control
18	0.5 TN/WH	845	Fuel Injector 5 Control
19	0.5 YE/BK	846	Fuel Injector 6 Control
20	0.5 TN	1744	Fuel Injector 1 Control
21	0.5 YE	410	Engine Coolant Temperature (ECT) Sensor Signal
22	0.5 TN	2761	Low Reference
23-25	--	--	Not Used
26	0.8 D-BU	496	Knock Sensor (KS) 1 Signal
27	0.8 GY	1716	Knock Sensor (KS) 1 Signal
28	--	--	Not Used
29	0.8L-BU	1876	Knock Sensor (KS) 2 Signal
30	0.8 GY	2303	Knock Sensor (KS) 2 Signal

4.8L (LY2) - 5.3L (LMF) - 6.0L (LY6) - Engine Control Module (ECM) - Connector X2 (cont'd)

Pin	Wire Color	Circuit No.	Function
31	--	--	Not Used
32	0.5 GY	23	Generator Field Duty Cycle Signal
33	0.5 BN	1174	Oil Level Switch Signal
34	0.35 BK	2755	Low Reference
35	0.35 TN	2752	Low Reference
36	--	--	Not Used
37	0.5 L-GN/BK	1745	Fuel injector 2 Control
38	0.5 PK/BK	1746	Fuel Injector 3 Control
39	0.5 L-BU/BK	844	Fuel Injector 4 Control
40	0.5 OG/BK	877	Fuel Injector 7 Control
41	0.35 GY	2705	5-Volt Reference 1
42	--	--	Not Used
43	0.35 GY	2704	5-Volt Reference 1
44	0.35 D-BU	6259	5-Volt Reference 1
45-49	--	--	Not Used
50	0.35 TN/WH	331	Oil Pressure Sensor Signal
51	--	--	Not Used
52	0.8 TN	2199	Low Reference (LY6)
53	0.35 OG/BK	469	Low Reference
54-55	--	--	Not Used
56	0.8 TN	1664	Heated Oxygen Sensor (HO2S) Low Signal - Bank 1 Sensor 1
57	0.8 PU/WH	1665	Heated Oxygen Sensor (HO2S) High Signal - Bank 1 Sensor 1
58	0.35 L-GN	432	Manifold Absolute Pressure (MAP) Sensor Signal
59	0.8 PU	1666	Heated Oxygen Sensor (HO2S) High Signal - Bank 2 Sensor 1

Pin	Wire Color	Circuit No.	Function
60	0.8 TN	1667	Heated Oxygen Sensor (HO2S) Low Signal - Bank 2 Sensor 1
61	0.5 OG	225	Generator Turn On Signal
62	--	--	Not Used
63	0.35 PU	486	Throttle Position (TP) Sensor 2 Signal
64	0.35 D-BU/WH	6265	Camshaft Position (CMP) Sensor Signal
65	0.35 D-GN	485	Throttle Position (TP) Sensor 1 Signal
66	0.35 BN	6266	Low Reference
67	--	--	Not Used
68	0.35 WH/BK	6271	Crankshaft Position (CKP) Sensor Signal
69	0.35 GY/BK	6272	Low Reference
70	0.8 PU	2121	Ignition Coil 1 Control
71	0.8 PU/WH	2128	Ignition Coil 8 Control
72	0.8 OG	2127	Ignition Coil 7 Control
73	0.8 OG/WH	2122	Ignition Coil 2 Control
74	0.8 L-BU/WH	2126	Ignition Coil 6 Control
75	0.8 D-GN	2125	Ignition Coil 5 Control
76	0.8 D-GN/WH	2124	Ignition Coil 4 Control
77	0.8 L-BU	2123	Ignition Coil 3 Control
78	0.8 BN	2129	Low Reference
79	0.8 BN/WH	2130	Low Reference
80	--	--	Not Used

6.6L (LMM) – Engine Control Module (ECM) – Connector X1

Connector Part Information

OEM: 15438366
 Service: 19149311
 Description: 96-Way F Sealed (BK)

Terminal Part Information

Pins: 1-3, 25-27, 49-51, 73-75, 77, 4-6, 9, 11-15, 17, 19-24, 28, 30, 33, 35-45, 47, 48, 53, 56, 62-72, 76, 78, 79, 83, 86, 88, 90-96

Terminal/Tray: 1928498135/19

Core/Insulation Crimp: Pins 1-3, 25-27, 49, 50, 51, 73-75, 77 - K/K

Core/Insulation Crimp: 4-6, 9, 11-15, 17, 19-24, 28, 30, 33, 35-45, 47, 48, 53, 56, 62-72, 76, 78, 79, 83, 86, 88, 90-96 - J/J

Release Tool/Test Probe: J-38125-213/J-35616-64B (L-BU)

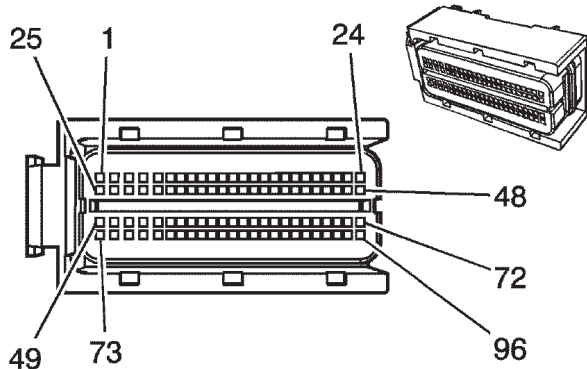

Pin	Wire Color	Circuit No.	Function
1	1 OG	5421	Fuel Injector Supply Voltage 1
2	1D-BU/WH	878	Fuel Injector 8 Control
3	1 OG/BK	877	Fuel Injector 7 Control
4	0.5 D-BU	2364	Cooling Fan Speed Signal
5	0.5 YE	492	Mass Air Flow (MAF) Sensor Signal
6	0.5 OG/BK	469	Low Reference
7-8	--	--	Not Used
9	0.5 BN	1174	Oil Level Switch Signal

Pin	Wire Color	Circuit No.	Function
10	--	--	Not Used
11	0.5 GY/BK	6272	Low Reference
12	0.5 GY	2704	5-Volt Reference 3
13	0.5 TN	5928	5-Volt Reference 3
14	0.5 GY	6054	5-Volt Reference 2
15	0.5 GY	2705	5-Volt Reference 2
16	--	--	Not Used
17	0.5 GY	2701	5-Volt Reference 1
18	--	--	Not Used
19	0.5 L-GN	432	Manifold Absolute Pressure (MAP) Sensor Signal
20	0.5 YE	5947	Turbocharger Vane Position Sensor Signal
21	0.5 L-BU	1162	Accelerator Pedal Position (APP) Sensor 2 Signal
22	0.5 YE/BK	508	Water In Fuel Indicator Control
23	0.5 BK	2755	Low Reference
24	0.5 PU/WH	2530	Fuel Pressure Regulator Solenoid Control
25	1 PK	5425	Fuel Injector Supply Voltage 4
26	1 YE/BK	846	Fuel Injector 6 Control
27	1 PK/BK	1746	Fuel Injector 3 Control
28	0.5 WH/BK	2366	Cooling Fan Clutch Control
29	--	--	Not Used
30	0.5 OG/BK	2919	Low Reference
31-32	--	--	Not Used
33	0.5 GY/BK	2931	Low Reference
34	--	--	Not Used

6.6L (LMM) – Engine Control Module (ECM) – Connector X1 (cont'd)

Pin	Wire Color	Circuit No.	Function
35	0.5 YE/BK	6055	Low Reference
36	0.5 TN	2752	Low Reference
37	0.5 GY	2702	5-Volt Reference 3
38	0.5 TN	1274	5-Volt Reference 2
39	0.5 TN	2917	5-Volt Reference 2
40	0.5 PU/WH	6270	5-Volt Reference 1
41	0.5 D-BU	6259	5-Volt Reference 1
42	0.5 TN	472	Intake Air Temperature (IAT) Sensor Signal
43	0.5 D-BU	6053	DPF Sensor Signal
44	0.5 TN/WH	331	Oil Pressure Sensor Signal
45	0.5 L-GN	2032	Engine Coolant Temperature (ECT) Sensor Signal
46	--	--	Not Used
47	0.5 TN	2761	Low Reference
48	0.5 D-BU	5930	Turbocharger Vane Position Control Solenoid Valve Control Circuit
49	1 PU	5423	Fuel Injector Supply Voltage 3
50	1 TN/WH	845	Fuel Injector 5 Control
51	1 L-BU/BK	844	Fuel Injector 4 Control
52	--	--	Not Used
53	0.5 YE/BK	6120	Low Reference
54-55	--	--	Not Used
56	0.5 BU/WH	6265	Camshaft Position (CMP) Sensor Signal
57-61	--	--	Not Used

Pin	Wire Color	Circuit No.	Function
62	0.5 TN	2760	Low Reference
63	0.5 OG/BK	5929	Low Reference
64	--	--	Not Used
65	0.5 L-BU	6118	Air Temperature Sensor Signal
66	0.5 D-BU	5277	Exhaust Gas Recirculation Temperature Sensor 1 Supply Voltage
67	0.5 BN/WH	5763	Exhaust Gas Recirculation (EGR) Valve Sensor Signal
68	0.5 YE	410	Engine Coolant Temperature (ECT) Sensor Signal
69	0.5 D-BU	5277	Exhaust Gas Temperature Sensor Signal
70	0.5 BN	6274	Low Reference
71	0.5 YE/BK	625	Starter Enable Relay Control
72	0.5 YE	2834	Fuel Pressure Regulator Solenoid Control
73	1 YE	5422	Fuel Injector Supply Voltage 2
74	1 TN	1744	Fuel Injector 1 Control
75	1 L-GN/BK	1745	Fuel Injector 2 Control
76	0.5 PK	1339	Ignition Voltage
77	1 RD/WH	440	Battery Positive Voltage
78	0.5 PU	1272	Low Reference
79	0.5 WH/BK	6271	Crankshaft Position (CKP) Sensor Signal

6.6L (LMM) – Engine Control Module (ECM) – Connector X1 (cont'd)

Pin	Wire Color	Circuit No.	Function
80-82	--	--	Not Used
83	0.5 L-BU/WH	6311	Torque Converter Clutch (TCC) Brake Signal
84-85	--	--	Not Used
86	0.5 TN	2753	Low Reference
87	--	--	Not Used
88	0.5 BN	6266	Low Reference
89	--	--	Not Used
90	0.5 L-BU	5377	Exhaust Gas Recirculation Temperature Sensor 2 Supply Voltage

Pin	Wire Color	Circuit No.	Function
91	0.5 D-GN	485	Throttle Position (TP) Sensor 1 Signal
92	0.5 YE	2918	Fuel Rail Pressure (FRP) Sensor Signal
93	0.5 L-BU	5377	Exhaust Gas Temperature Sensor Signal
94	0.5 GY/BK	6290	Low Reference
95	0.5 BN	6782	Low Reference
96	0.5 WH	5931	Low Reference

6.6L (LMM) - Engine Control Module (ECM) - Connector X2

Connector Part Information

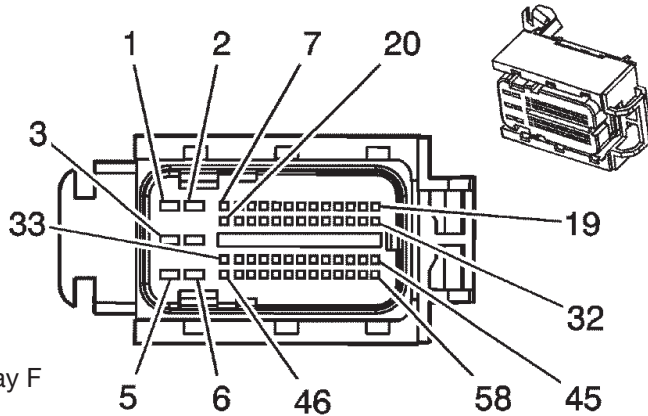

OEM: 15462694

Service: 88988935

Description: 58-Way F
Mixed Sealed (BK)

Terminal Part Information

Pins: 1-6

Terminal/Tray: 1928498059/24

Core/Insulation Crimp: 2/5

Release Tool/Test Probe: J-38125-561/J-35616-35 (VT)

Pins: 7, 12, 13, 15, 16, 19-21, 23, 24, 26-31, 33-36, 38, 39, 41, 44-49, 52, 54, 56, 57

Terminal/Tray: 1928498135/19

Core/Insulation Crimp: J/J

Release Tool/Test Probe: J-38125-213/J-35616-64B (L-BU)

Pin	Wire Color	Circuit No.	Function
1	2 PK	1439	Ignition Voltage
2	2 BK/WH	1551	Ground
3	2 PK	1439	Ignition Voltage
4	2 BK/WH	1551	Ground
5	2 PK	1439	Ignition Voltage
6	2 BK/WH	1551	Ground
7	0.8 BN	582	Throttle Actuator Control Motor Control - 2
8-11	--	--	Not Used

Pin	Wire Color	Circuit No.	Function
12	0.5 D-GN/WH	465	Fuel Pump Relay Control - Primary
13	0.5 TN	5514	Low Reference (C60)
14	--	--	Not Used
15	0.5 WH/BK	1164	5-Volt Reference 3
16	0.5 D-BU	507	Wait to Start Indicator Controller
17-18	--	--	Not Used
19	0.5 YE	5991	Powertrain Relay Control
20	0.8 YE	581	Throttle Actuator Control Motor Control - 1
21	0.5 PK	439	Ignition Voltage
22	--	--	Not Used
23	0.8 OG	225	Generator Turn On Signal
24	0.8 GN/WH	7076	Charge Indicator Control (KD9)
25	--	--	Not Used
26	0.5 BN/WH	6141	Low Reference
27	0.5 GY	2700	5-Volt Reference 2 (C60)
28	0.5 GY	2365	5-Volt Reference 1
29	0.5 BN	1271	Low Reference
30	0.5 BN/WH	419	MIL Control
31	0.5 D-GN/WH	459	A/C Compressor Clutch Relay Control (C60)
32	--	--	Not Used
33	0.5 OG/BK	5764	Exhaust Gas Recirculation Valve Motor High Control
34	0.5 TN	2759	Low Reference
35	0.5 OG/BK	380	A/C Refrigerant Pressure Sensor Signal (C60)
36	0.5 PU	1589	Fuel Level Sensor Signal - Primary

6.6L (LMM) – Engine Control Module (ECM) – Connector X2 (cont'd)

Pin	Wire Color	Circuit No.	Function
37	--	--	Not Used
38	0.8 GY	23	Generator Field Duty Cycle Signal
39	0.5 OG/BK	1786	Ignition Lock Cylinder Control Actuator Signal
40	--	--	Not Used
41	0.5 D-BU	6863	Low Reference
42-43	--	--	Not Used
44	0.5 TN	2501	High Speed GMLAN Serial Data Bus (-)
45	0.5 OG/BK	6399	Replicated TOS Signal
46	0.5 L-GN/BK	5746	Exhaust Gas Recirculation (EGR) Valve Motor Low Control
47	0.5 BN	6062	Low Reference
48	0.5 YE	1578	Fuel Temperature Signal
49	0.5 D-BU	1161	Accelerator Pedal Position (APP) Sensor 1 Signal

Pin	Wire Color	Circuit No.	Function
50-51	--	--	Not Used
52	0.5 BN/WH	6783	Low Reference
53	--	--	Not Used
54	0.5 YE/BK	1827	Vehicle Speed Signal
55	--	--	Not Used
56	0.5 D-BU	5985	Accessory Wakeup Serial Data
57	0.5 TN/BK	2500	High Speed GMLAN Serial Data Bus (+)
58	--	--	Not Used

HVAC Control Assembly - Location View

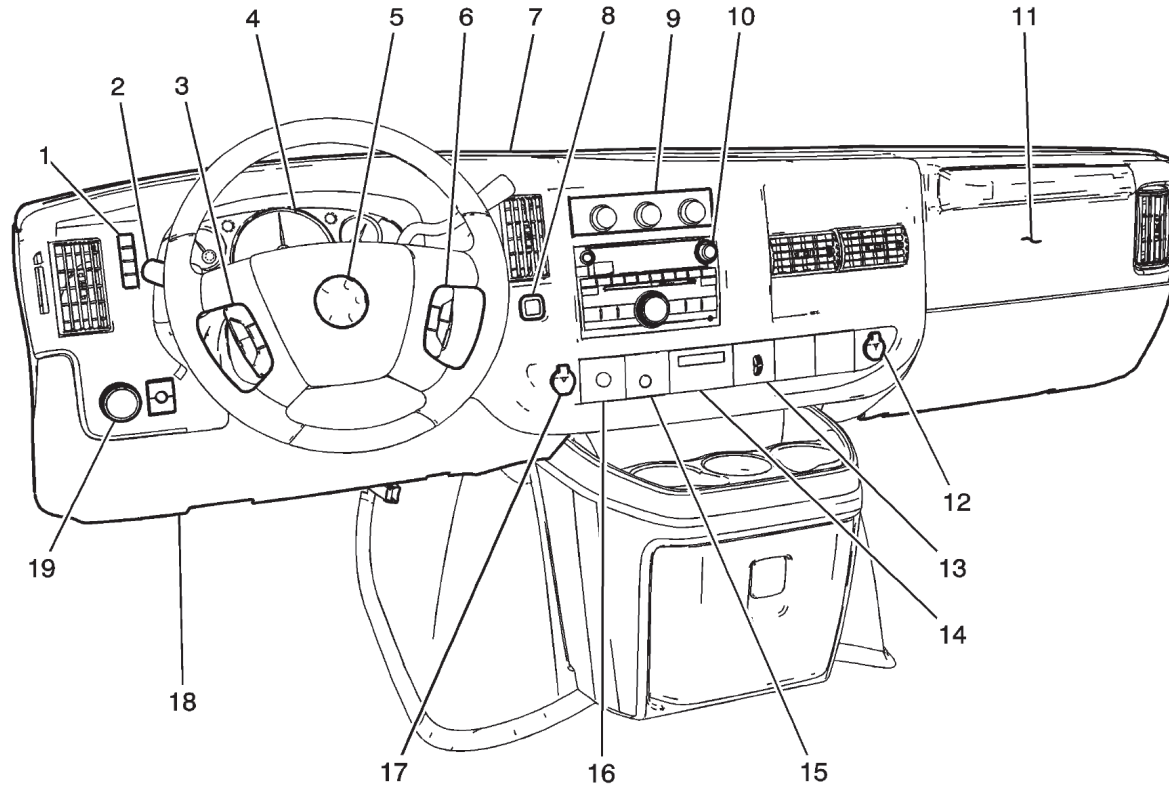

- | | |
|---|--|
| (1) Driver Information Center (DIC) | (11) Inflatable Restraint I/P Module |
| (2) Turn Signal/Multifunction Switch | (12) Accessory Power Outlet - Center Console 2 |
| (3) Steering Wheel Control Switch - Left (K34) | (13) Blower Motor Switch - Auxiliary (C36 without C69) |
| (4) Instrument Panel Cluster (IPC) | (14) Inflatable Restraint I/P Module Indicator (Light Duty without YF7) |
| (5) Inflatable Restraint Steering Wheel Module | (15) Inflatable Restraint I/P Module Disable Switch (C99) |
| (6) Steering Wheel Control Switch - Right (W1Y) | (16) Traction Control Switch (TCS) (JL4) |
| (7) Instrument Panel | (17) Cigar Lighter (DT4) / Accessory Power Outlet - Center Console 1 (without DT4) |
| (8) Tow/Haul Switch | (18) Data Link Connector (DLC) |
| (9) HVAC Control Assembly | (19) Headlamp and Panel Dimmer Switch |
| (10) Radio | |

HVAC Control Assembly – Connector End Views – X1

Connector Part Information

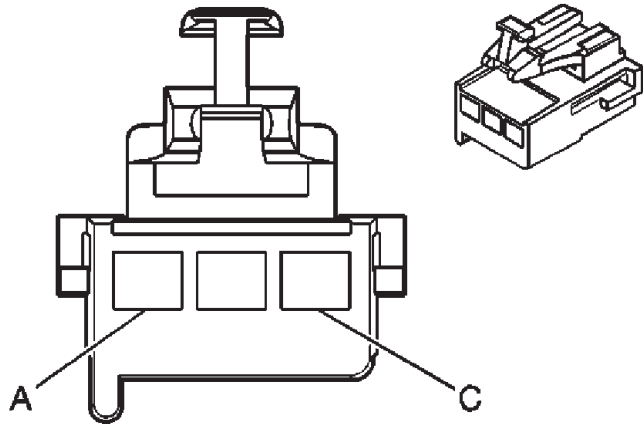

OEM: 12129489

Service: 12129489

Description: 3-Way F
Metri-Pack 280 Series Flexlock (BK)

Terminal Part Information

Pins: C

Terminal/Tray: 12110844/4

Core/Insulation Crimp: E/C

Release Tool/Test Probe: 15315247/J-35616-4A (PU)

Pins: A, B

Terminal/Tray: 12110844/4

Core/Insulation Crimp: Pins A - C/A

Core Insulation Crimp : Pins B - E/A

Release Tool/Test Probe: 15315247/J-35616-4A (PU)

Pin	Wire Color	Circuit No.	Function
A	1 WH	119	Blower Motor Switch Control
B	0.5 BK	550	Ground
C	0.35	230	Instrument Panel Lamps Dimming

HVAC Control Assembly – Connector End Views – X2

Connector Part Information

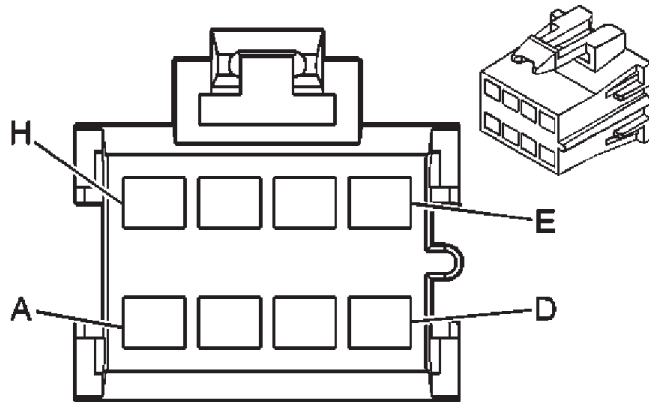

OEM: 12064998

Service: 15306189

Description: 8-Way F
Metri-Pack 280 Series (BK)

Terminal Part Information

Pins: H

Terminal/Tray: 12034046/2

Core/Insulation Crimp: E/A

Release Tool/Test Probe: 12094430/J-35616-4A (PU)

Pins: A - G

Terminal/Tray: 12066214/2

Core/Insulation Crimp: Pins A - D, F - See Terminal Repair Kit

Core Insulation Crimp : Pins E, G - F/D

Release Tool/Test Probe: 12094430/J-35616-4A (PU)

Pin	Wire Color	Circuit No.	Function
A	0.8 YE	60	Blower Motor Low Control
B	0.8 TN	63	Blower Motor Medium Control
C	0.8 L-BU	72	Medium 2 Blower Motor Control
D	0.8 OG	52	Blower Motor High Control
E	1 BN	141	Ignition Voltage
F	0.8 L-BU	733	Air Temperature Door Control
G	1 WH	119	Blower Motor Switch Control
H	0.5 D-GN/WH	762	A/C Request Signal (C60)

HVAC Control Assembly – Connector End Views – X3

Connector Part Information

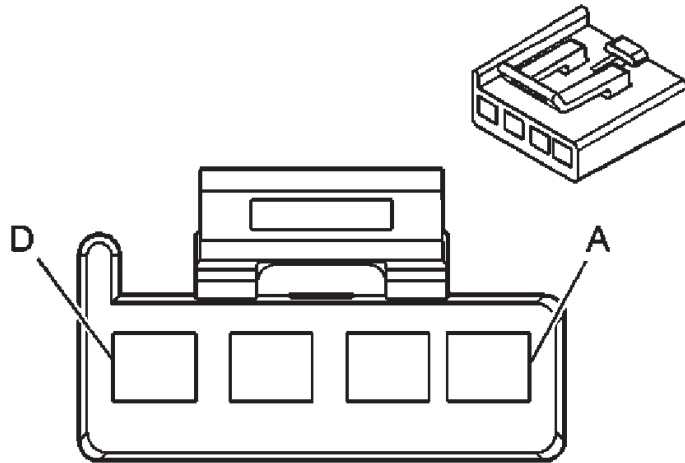

OEM: 12052856

Service: 12125636

Description: 4-Way F
Metri-Pack 280 Series (BK)

Terminal Part Information

Pins: A

Terminal/Tray: 12066214/2

Core/Insulation Crimp: See Terminal Repair Kit

Release Tool/Test Probe: 12094430/J-35616-4A (PU)

Pins: B-D

Terminal/Tray: 12034046/2

Core/Insulation Crimp: E/A

Core Insulation Crimp : Pins E, G - F/D

Release Tool/Test Probe: 12094430/J-35616-4A (PU)

Pin	Wire Color	Circuit No.	Function
A	0.8 RD/WH	4440	Battery Positive Voltage (C49/DE5/DE7)
B	0.35 BN	341	Ignition Voltage
C	0.5 BK	550	Ground
D	0.35 WH	193	Rear Defog Relay Control (C49/DE5/DE7)

HVAC Control Assembly – Connector End Views – X4 (C60)

Connector Part Information

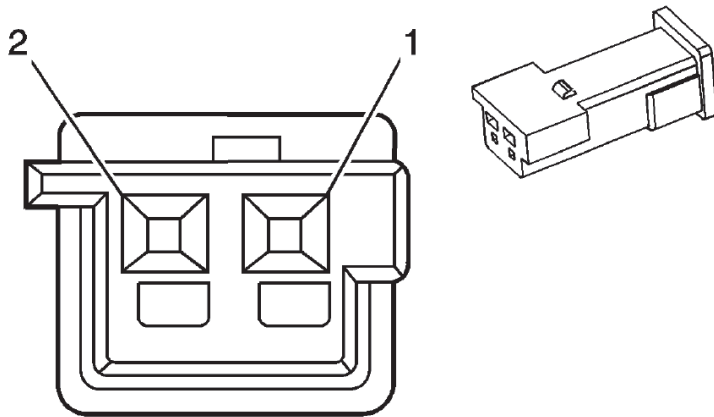

Pin	Wire Color	Circuit No.	Function
1	0.5 L-GN	66	A/C Request Signal
2	0.5 D-GN/WH	762	A/C Request Signal

OEM: 15318080

Service: 21019410

Description: 2-Way F
Metri-Pack 280 Series (BK)

Terminal Part Information

Terminal/Tray: See Terminal Repair Kit

Core/Insulation Crimp: See Terminal Repair Kit

Release Tool/Test Probe: See Terminal Repair Kit

Transmission Control Module (TCM) – Location View

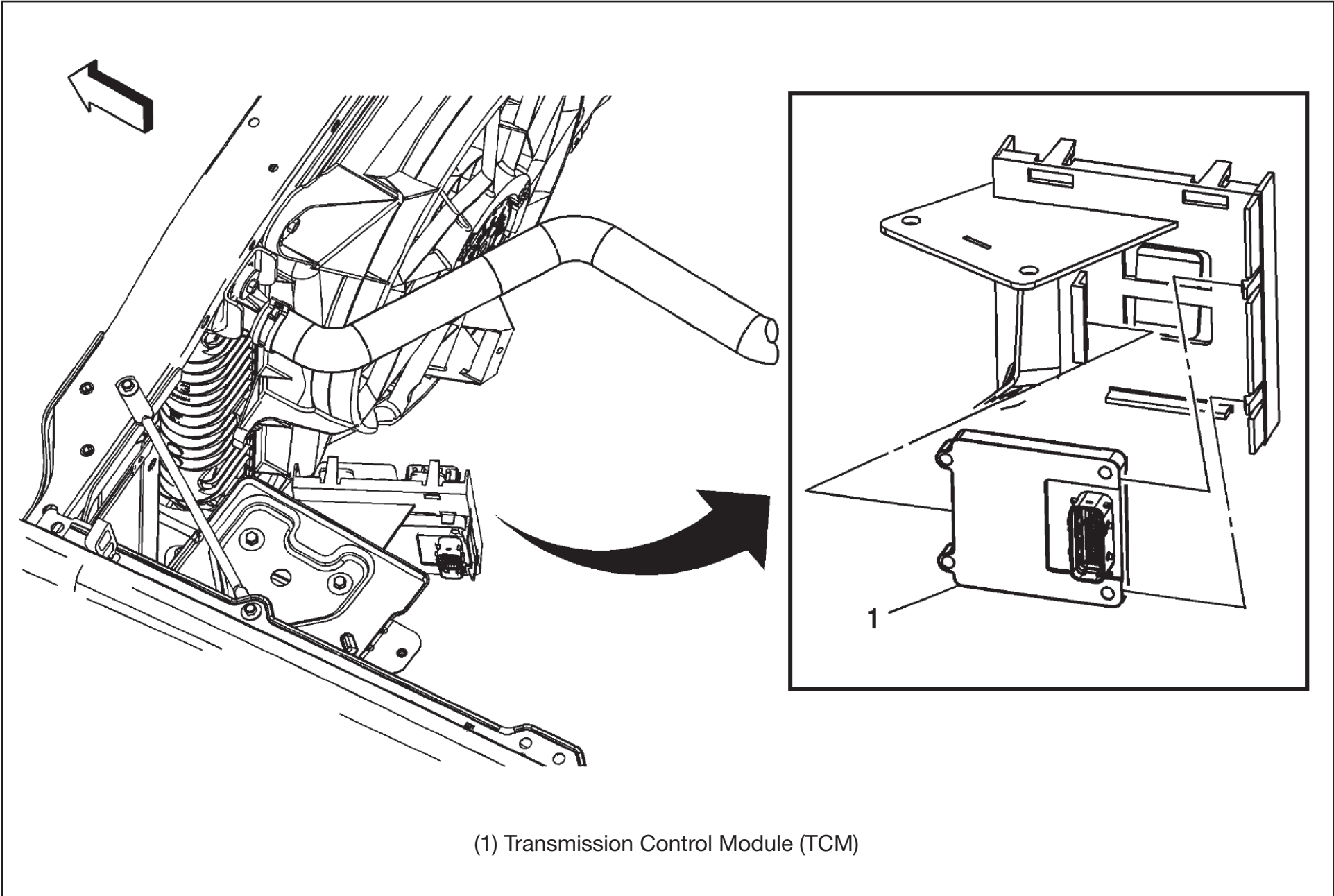

Transmission Control Module (TCM) – Connector End View – Diesel Engine

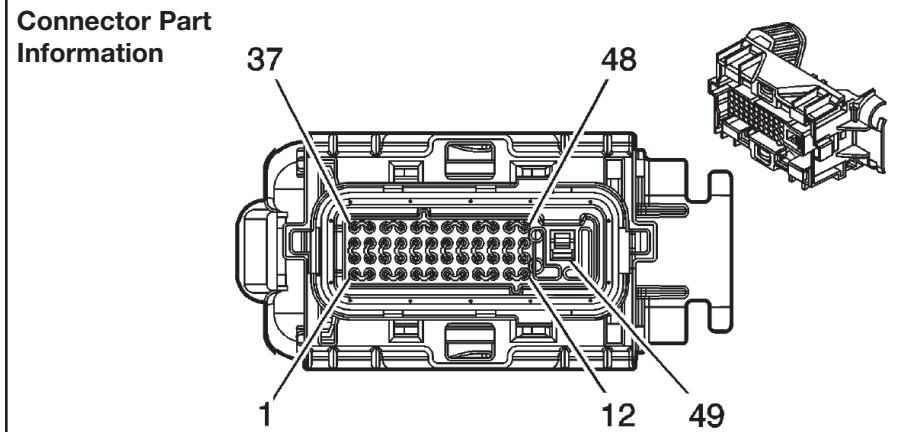

OEM: 15463921

Service: 88987979

Description: 49-Way F
GT 280 Micro-Pack 64 Sealed (BK)

Terminal Part Information

Pins: 1-3, 5-7, 11, 15-17, 19, 20, 23, 24, 26, 29-33, 35, 37-42, 44, 46

Terminal/Tray: 15359541/4

Core/Insulation Crimp: M/M

Release Tool/Test Probe: 15381651-2/J-35616-64B (L-BU)

Pins: 49

Terminal/Tray: 15392777/23

Core/Insulation Crimp: See Terminal Repair Kit

Release Tool/Test Probe: J-38125-553/J-35616-4A (PU)

Pin	Wire Color	Circuit No.	Function
1	0.5 BN	418	Torque Converter Clutch Pulse Width Modulation (TCC PWM) Solenoid Valve Control
2	0.5 L-GN	1222	Shift Solenoid A Valve Control

Pin	Wire Color	Circuit No.	Function
3	0.5 OG/BK	1230	Automatic Transmission Input Speed Sensor (AY ISS) High Signal
4	--	--	Not Used
5	0.5 OG/BK	6399	Replicated TOS Signal
6	0.5 TN	2501	High Speed GMLAN Serial Data Bus (-)
7	0.5 TN/BK	2500	High Speed GMLAN Serial Data Bus (+)
8-10	--	--	Not Used
11	0.5 D-BU	5985	Accessory Wakeup Serial Data
12-14	--	--	Not Used
15	0.5 TN	2501	High Speed GMLAN Serial Data Bus (-)
16	0.5 L-GN.BK	822	Vehicle Speed Sensor (VSS) Low Signal
17	0.35 L-BU/WH	1229	PC Solenoid Valve Low Control (Sol. A)
18	--	--	Not Used
19	0.5 TN/BK	2500	High Speed GMLAN Serial Data Bus (+)
20	0.5 YE/BK	1223	Shift Solenoid B Valve Control
21-22	--	--	Not Used
23	0.5 GY	773	Transmission Range Switch Signal C
24	0.35 PK	1224	Transmission Fluid Pressure Switch Signal A
25	--	--	Not Used
26	0.5 D-BU/WH	1231	Automatic Transmission Input Speed Sensor (AT ISS) Low Signal

Transmission Control Module (TCM) – Connector End View – Diesel Engine (cont'd)

Pin	Wire Color	Circuit No.	Function
27-28	--	--	Not Used
29	0.5 TN/WH	771	Transmission Range Switch Signal A
30	0.35 TN	452	Low Reference
31	0.5 PK	2139	Ignition Voltage
32	0.35 RD/WH	1840	Battery Positive Voltage
33	0.35 OG	1226	Transmission Fluid Pressure Switch Signal C
34	--	--	Not Used
35	0.35 YE/BK	1227	Transmission Fluid Temperature (TFT) Sensor Signal
36	--	--	Not Used
37	0.5 TN	2501	High Speed GMLAN Serial Data Bus (-)
38	0.5 TN/BK	2500	High Speed GMLAN Serial Data Bus (+)

Pin	Wire Color	Circuit No.	Function
39	0.5 WH	776	Transmission Range Switch Signal P
40	0.35 OG/BK	1228	PC Solenoid Valve High Control (Sol. A)
41	0.5 PU/WH	821	Vehicle Speed Sensor (VSS) High Signal
42	0.5 L-BU/WH	6311	Torque Converter Clutch (TCC) Brake Signal
43	--	--	Not Used
44	0.35 D-BU	1225	Transmission Fluid Pressure Switch Signal B
45	--	--	Not Used
46	0.5 YE	772	Transmission Range Switch Signal B
47-48	--	--	Not Used
49	2 BK/WH	1551	Ground

Transmission Control Module (TCM) – Connector End View – Gas Engine

Connector Part Information

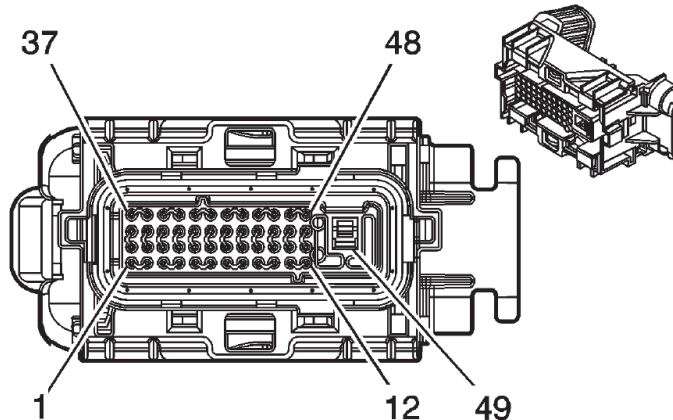

OEM: 15463921

Service: 88987979

Description: 49-Way F
GT 280 Micro-Pack 64 Sealed (BK)

Terminal Part Information

Pins: 1-3, 5-7, 11, 14-17, 19, 20, 23-26, 29, 30,-33, 35, 37-42, 44-46

Terminal/Tray: 15359541/4

Core/Insulation Crimp: M/M

Release Tool/Test Probe: 15381651-2/J-35616-64B (L-BU)

Pins: 49

Terminal/Tray: 15392777/23

Core/Insulation Crimp: See Terminal Repair Kit

Release Tool/Test Probe: J-38125-553/J-35616-4A (PU)

Pin	Wire Color	Circuit No.	Function
3	0.35 BN/WH	6254	ISS Signal (4L60)
	0.5 OG/BK	1230	Automatic Transmission Input Speed Sensor (AT ISS) High Signal (4L80)
5	0.5 OG/BK	6399	Replicated TOS Signal
6	0.5 TN	2501	High Speed GMLAN Serial Data Bus (-)
7	0.5 TN/BK	2500	High Speed GMLAN Serial Data Bus (+)
8-10	--	--	Not Used
11	0.5 D-BU	5985	Accessory Wakeup Serial Data
12-13	--	--	Not Used
14	0.5 WH	687	3-2 Shift Solenoid Valve Control (4L60)
15	0.5 TN	2501	High Speed GMLAN Serial Data Bus (-)
16	0.5 L-GN/BK	822	Vehicle Speed Sensor (VSS) Low Signal
17	0.35 L-BU/WH	1229	PC Solenoid Valve Low Control (Sol. A)
18	--	--	Not Used
19	0.5 TN/BK	2500	High Speed GMLAN Serial Data Bus (+)
20	0.5 YE/BK	1223	Shift Solenoid B Valve Control
21-22	--	--	Not Used
23	0.35 GY	773	Transmission Range Switch Signal C
24	0.35 PK	1224	Transmission Fluid Pressure Switch Signal A
25	0.5 TN/BK	422	Torque Converter Clutch (TCC) Solenoid Valve Control (4L60)

Pin	Wire Color	Circuit No.	Function
1	0.5 BN	418	Torque Converter Clutch Pulse Width Modulation (TCC PWM) Solenoid Control
2	0.5 L-GN	1222	Shift Solenoid A Valve Control

Transmission Control Module (TCM) – Connector End View – Gas Engine (cont'd)

Pin	Wire Color	Circuit No.	Function
26	0.5 D-BU/WH	1231	Automatic Transmission Input Speed Sensor (AY ISS) Low Signal (4L80)
27-28	--	--	Not Used
29	0.35 TN/WH	771	Transmission Range Switch Signal A
30	0.35 TN	452	Low Reference
31	0.5 PK	2139	Ignition Voltage
32	0.35 RD/WH	1840	Battery Positive Voltage
33	0.35 OG	1226	Transmission Fluid Pressure Switch Signal C
34	--	--	Not Used
35	0.35 YE/BK	1227	Transmission Fluid Temperature (TFT) Sensor Signal
36	--	--	Not Used
37	0.5 TN	2501	High Speed GMLAN Serial Data Bus (-)
38	0.5 TN/BK	2500	High Speed GMLAN Serial Data Bus (+)

Pin	Wire Color	Circuit No.	Function
39	0.35 WH	776	Transmission Range Switch Signal P
40	0.35 OG/BK	1228	PC Solenoid Valve High Control (Sol. A)
41	0.5 PU/WH	821	Vehicle Speed Sensor (VSS) High Signal
42	0.5 L-BU/WH	6311	Torque Converter Clutch (TCC) Brake Signal
43	--	--	Not Used
44	0.35 D-BU	1225	Transmission Fluid Pressure Switch Signal B
45	0.35 D-BU	6253	Low Reference (4L60)
46	0.35 YE	772	Transmission Range Switch Signal B
47-48	--	--	Not Used
49	2 BK/WH	1551	Ground

Fuse Blocks - Underhood - Location View

- (1) Vacuum Pump (6.6L)
- (2) Battery
- (3) Transmission Control Module (TCM)
- (4) Blower Motor Resistor Assembly
- (5) Blower Motor
- (6) Brake Fluid Level Switch (Heavy Duty)
- (7) Engine Control Module (ECM)
- (8) Fuse Block - Underhood**

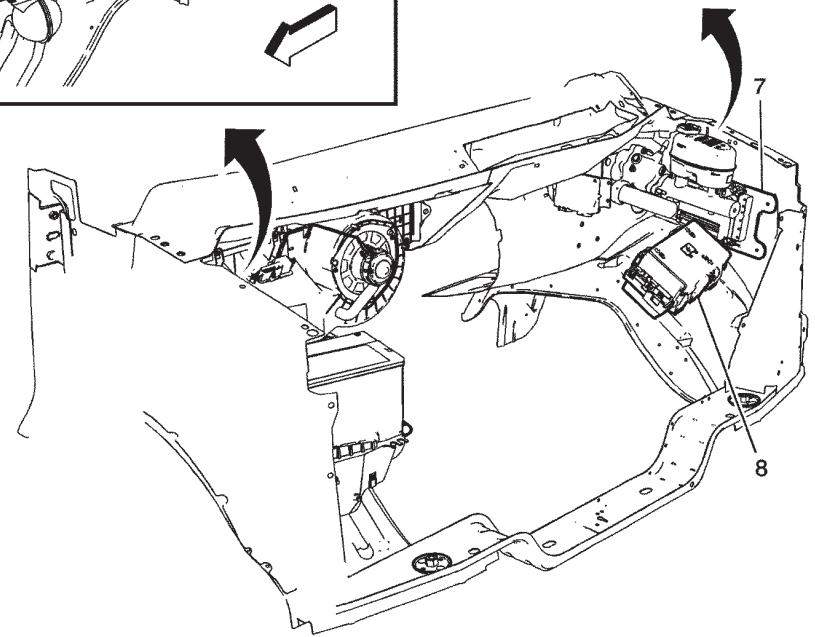
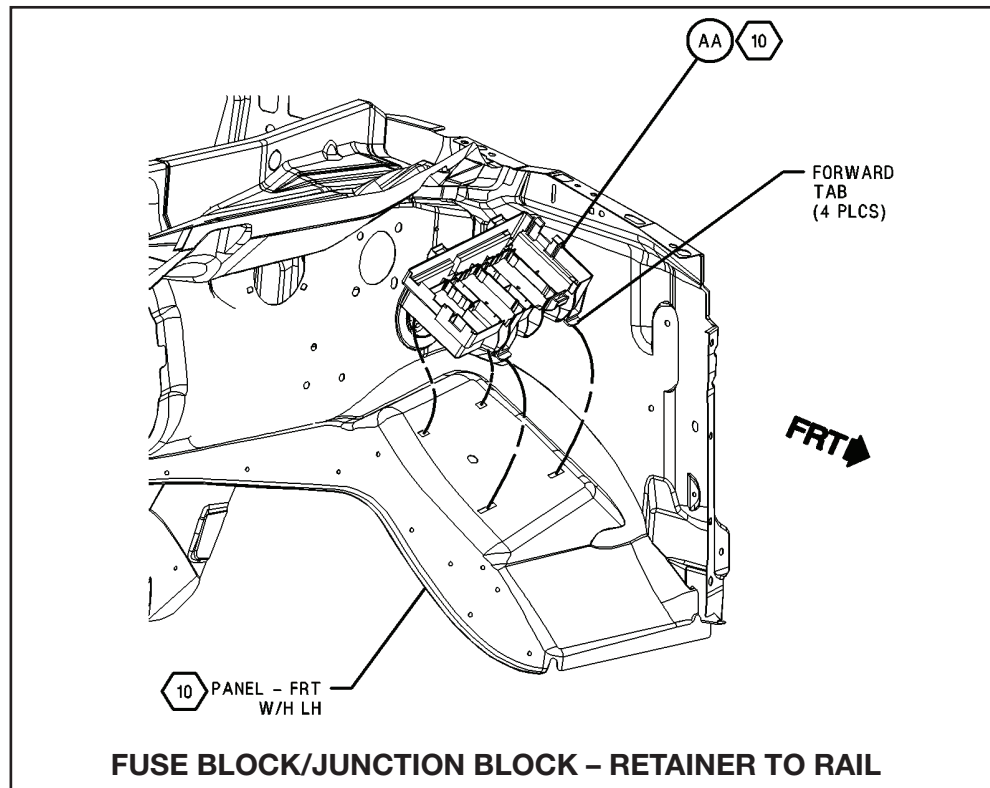
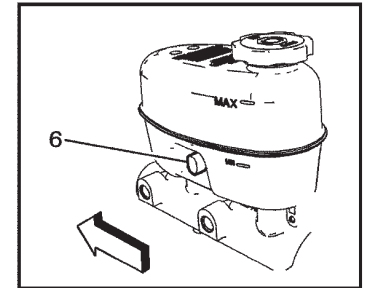
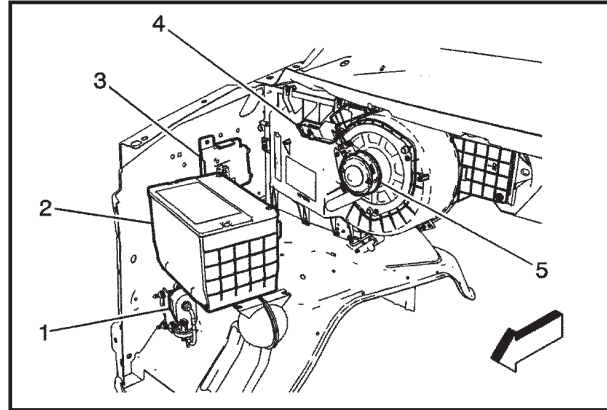

Fuse Blocks – Underhood – Label Usage

MINI FUSE:

1	- LT HI BEAM	(10A)
2	- FUEL PUMP	(20A)
3	- EMPTY	
4	- FUEL HTR (D)	(15A)
5	- RT HI BEAM	(10A)
6	- EMPTY	
7	- LT LO BEAM	(10A)
8	- RT STP/TRN TRLR	(15A)
9	- RT LO BEAM	(10A)
10	- DRL 2	(10A)
11	- FCSM IGN (G)	(10A)
12	- DRL 1	(15A)
13	- AUX STOP LAMP	(15A)
14	- FOH MDL (D)	(15A)
15	- FSCM BATT (G)	(20A)
16	- LT STP/TRN TRLR	(15A)
17	- CNSTR VENT SOL (G)	(10A)
18	- EMPTY	
19	- EMPTY	
20	- BCM - 1	(10A)
21	- SEO	(10A)
22	- BCM - 4	(10A)
23	- BCM - 6	(10A)
24	- EMPTY	
25	- BCM - 7	(10A)
26	- BCM - 3	(10A)
27	- BCM - 5	(10A)
28	- EMPTY	
29	- EMPTY	
30	- IP CLSTR	(10A)
31	- EMPTY	
32	- BRK SW	(10A)
33	- AUX PWR OUTLET	(20A)
34	- AIRBAG	(10A)
35	- TRLR WRG	(30A)
36	- STR/WHL SNSR (G)	(10A)
37	- BCM - 2	(15A)
38	- LTR/DLC	(20A)
39	- WPR	(25A)
40	- EMPTY	
41	- WSW	(15A)
42	- EMPTY	
43	- HORN	(20A)
44	- TCM BATT	(10A)
45	- EMPTY	
46	- O2 SNSR 1 (G)	(10A)

47	- TCM IGN	(15A)
48	- ECM IGN	(15A)
49	- MAF/CNSTR VENT	(15A)
50	- ECM PWR/TRN	(10A)
51	- TRANS	(15A)
52	- EVEN IGN/INJ (G)	(20A)
53	- GLOW PLUG MDL (D)	(10A)
54	- ECM BATT (G)	(10A)
55	- ODD IGN/INJ (G)	(20A)
56	- O2 SNSR 2 (G)	(10A)
57	- A/C CMPRSR	(15A)
58	- FAN CLTCH (D)	(10A)
59	- V6 FUEL INJ (G)	(15A)

J - CASE FUSE :

60	- ABS MDL	(40A)
61	- ABS MTR	(50A)
62	- TRLR WRG	(30A)
63	- SPARE	
64	- STRTR SOL	(40A)
65	- ECM PWR/TRN (D)	(30A)
66	- FRT BLWR	(40A)
67	- SPARE	

MICRO RELAY :

68	- SPARE	
----	---------	--

HIGH CURRENT MICRO RELAY :

69	- RUN/CRNK	
70	- WPR - HI	
71	- WPR	
73	- CRNK	
76	- PWR/TRN	

MINI MICRO RELAY :

72	- FUEL PUMP	
74	- A/C CMPRSR	

SOLID STATE RELAY :

75	- FAN CLTCH (D)	
----	-----------------	--

MEGA FUSE :

77	-	(125A)
----	---	--------

* NOTE : The function and amperage of these fuses are different, depending on vehicle content.

(G) = GAS
(D) = DIESEL

* REMARQUE : La fonction et l'intensite de ces fusibles different suivant l'equipement du vehicule.

(G) = ESSENCE
(D) = DIESEL

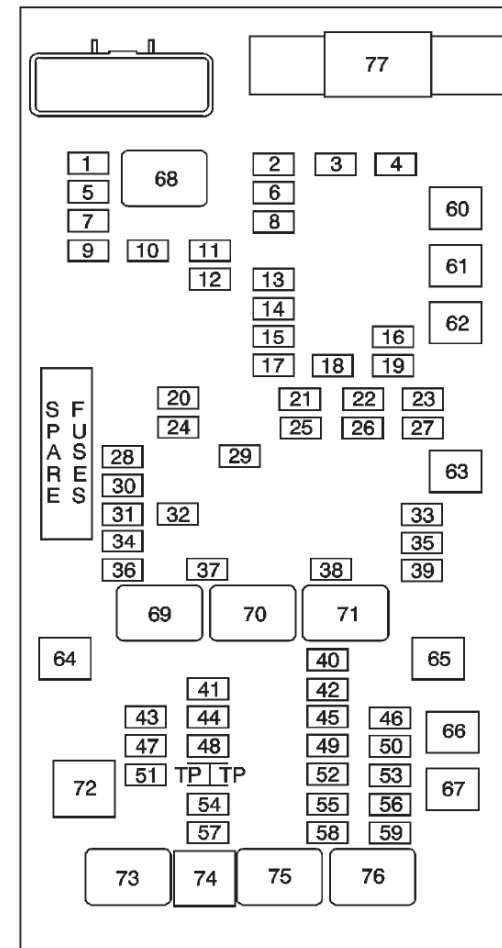

Fuse Block - Underhood - Label Usage (cont'd)

No.	Device	Rating	Description
1	LT HI BEAM Fuse	10A	Headlamp - High Beam - left (Composite) or Headlamp - Left (Sealed)
2	FUEL PUMP Fuse	20A	Fuel Pump and Sender Assembly (4.3L/4.8L.6.0L) or Fuel Pump (6.6L)
3	EMPTY	--	Not Used
4	FUEL HTR (D) Fuse	15A	Fuel Heater (6.6L)
5	RT HI BEAM Fuse	10A	Headlamp - High Beam (Composite) or Headlamp - Right (Sealed)
6	EMPTY	--	Not Used
7	FT LO BEAM Fuse	10A	Headlamp - Low Beam - Left (Composite) or Headlamp - Left (Sealed)
8	RT STP/TRN TRLR Fuse	15A	Trailer Connector
9	FT LO BEAM Fuse	10A	Headlamp - Low Beam - Right (Composite) or Headlamp - Right (Sealed)
10	DRL 2 Fuse	10A	LT LO BEAM fuse and Headlamp - Left (Sealed)
11	FCSM IGN (G) Fuse	10A	Fuel Pump Flow Control Module (5.3L)
12	DRL 1 Fuse	15A	LT LO BEAM Fuse and Headlamp - Low Beam - Left (Composite)
13	AUX STOP LAMP Fuse	15A	X405 (Cutaway)
14	FOH MDL (D) Fuse	15A	Coolant Heater (6.6L)
15	FCSM BATT (G) Fuse	20A	Fuel Pump Flow Control Module (5.3L)
16	LT STP/TRN TRLR Fuse	15A	Trailer Connector
17	CNSTR VENT SOL (G) Fuse	10A	Evaporative Emission (EVAP) Canister Vent Solenoid Valve (Gas)

No.	Device	Rating	Description
18	EMPTY	--	Not Used
19	EMPTY	--	Not Used
20	BCM 1 Fuse	10A	Body Control Module
21	SEO Fuse	10A	Instrument Panel Cluster (8S8)
22	BCM 4 Fuse	15A	Body Control Module
23	BCM 6 Fuse	15A	Body Control Module
24	EMPTY	--	Not Used
25	BCM 7 Fuse	10A	Body Control Module
26	BCM 3 Fuse	15A	Body Control Module
27	BCM 5 Fuse	15A	Body Control Module
28	EMPTY	--	Not Used
29	EMPTY	--	Not Used
30	IP CLSTR Fuse	10A	Instrument Panel Cluster
31	EMPTY	--	Not Used
32	BRK SW Fuse	10A	Stop Lamp Switch
33	AUX PWR OUTLET Fuse	20A	Accessory Power Outlet - Center Console 2
34	AIRBAG Fuse	10A	Inflatable Restraint Sensing and Diagnostic Module, Inflatable Restraint I/P Module Disable Switch (C99) or Inflatable Restraint I/P Module Indicator (without C99)
35	TRLR WRG Fuse	30A	Blunt Cut (UY7)
36	STR/WHL SNSR (G) Fuse	10A	Steering Wheel Speed/Position Sensor (JL4)
37	BCN 2 Fuse	10A	Body Control Module
38	LTR/DLC Fuse	20A	Cigar Lighter (DT4), Accessory Power Outlet - Center Console 1 (without DT4) and Data Link Connector (DLC)
39	WPR Fuse	25A	WPR Relay

Fuse Block - Underhood - Label Usage (cont'd)

No.	Device	Rating	Description
40	EMPTY	--	Not Used
41	WSW Fuse	15A	Windshield Washer Fluid Pump
42	EMPTY	--	Not Used
43	HORN Fuse	20A	Horn Assembly
44	TCM BATT Fuse	10A	Transmission Control Module
45	EMPTY	--	Not Used
46	O2 SNSR 1 (G) Fuse	10A	HO2S Bank 1 Sensor 1 (Gas) and HO2S Bank 2 Sensor 1 (Gas)
47	TCM IGN Fuse	15A	Transmission Control Module
48	ECM IGN Fuse	15A	Engine Control Module
49	MAF/CNSTR VENT Fuse	15A	Mass Air Flow (MAF)/Intake Air Temperature (IAT) Sensor and Evaporative Emission (EVAP) Canister Purge Solenoid Valve (Gas)
50	ECM PWR/TRN Fuse	10A	Engine Control Module
51	TRANS Fuse	15A	Automatic Transmission
52	EVEN IGN/INJ (G) Fuse	20A	Even Ignition Coils (4.8L/5.3L/6.0L) and Even Fuel injector (4.8L/5.3L/6.0L)
53	GLOW PLUG MDL (D) Fuse	10A	Glow Plug Control Module (GPCM) (6.6L)
54	ECM BATT (G) Fuse	10A	Engine Control Module
55	ODD IGN/INJ (G) Fuse	20A	Odd Ignition Coils (4.8L/5.3L/6.0L), Ignition Control Module (4.3L) and Odd Fuel injectors (4.8L/5.3L/6.0L)
56	O2 SNSR 2 (G) Fuse	10A	HO2S Bank 1 Sensor 2 (Gas) and HO2S Bank 2 Sensor 2 (Gas)
57	A/C CMPRSR Fuse	15A	A/C Compressor Clutch (C60)
58	FAN CLTCH (D) Fuse	10A	FAN CLTCH Relay (D) (6.6L)

No.	Device	Rating	Description
59	V6 FUEL INJ (F) Fuse	15A	Fuel injectors (4.3L)
60	ABS MDL Fuse	40A	Electronic Brake Control Module (EBCM)
61	ABS MTR Fuse	50A	Electronic Brake Control Module (EBCM)
62	TRLR WRG Fuse	30A	Trailer Connector
63	SPARE Fuse	--	Not Used
64	STRTR SOL Fuse	40A	Starter Motor
65	ECM PWR/TRN (D) Fuse	30A	Engine Control Module (6.6L)
66	FRT BLWR Fuse	40A	Blower Motor Resistor Assembly
67	SPARE Fuse	--	Not Used
68	SPARE Relay	--	Not Used
69	RUN/CRNK Relay	--	FCSM IGN (5.3L), IP CLSTR, TRANS, BRK SW, TCM IGN, ECM IGN, AIR BAG, STR/WHL SNSR (G), STRTR SOL Fuses
70	WPR - Hi Relay	--	Windshield Wiper Motor
71	WPR Relay	--	WPR - HI Relay and Windshield Wiper Motor
72	FUEL PUMP Relay	--	FUEL PUMP Fuse
73	CRNK Relay	--	STRTR SOL Fuse
74	A/C CMPRSR Relay	--	A/C CMPRSR Fuse
75	FAN CLUTCH (D) Relay	--	Cooling Fan (6.6L) and Engine Control Module (6.6L)
76	PWR/TRN Relay	--	FLOW PLUG MDL (D), FUEL HTR (D), o2 SNSR 1 (G), O2 SENSR 2 (G), ECM PWR/TRN, MAF CNSTR VENT, V6 FUEL INJ (G), EVEN IGN/INJ (G), ODD IGN/INJ (G), ECM PWR/TRN (D) and FAN CLTCH (D) Fuses

Fuse Block – Underhood – Label Usage (cont'd)

No.	Device	Rating	Description
77	MEGA Fuse	125A	Fuse Block - Body
IMPORTANT: Relays listed below are non-serviceable Printed Circuit Board (PCB) relays and are internal to the block			
--	HIGH BEAM PCB Relay	--	LT HIGH BEAM and RT HIGH BEAM Fuses
--	LOW BEAM PCB Relay	--	LT LO BEAM and RT LO BEAM Fuses
--	DRL PCB Relay	--	DRL 1 and DRL 2 Fuses

No.	Device	Rating	Description
--	TRAILER LH STOP/TURN PCB Relay	--	LT STP/TRN TRLR Fuse
--	TRAILER RH STOP/TURN PCB Relay	--	RT STP/TRN TRLR Fuse
--	WASHER PCB Relay	--	WSW Fuse
--	HORN PCB Relay	--	HORN Fuse
--	STOP LAMPS PCB Relay	--	AUX STOP LAMP Fuse

Fuse Block - Underhood - Top View

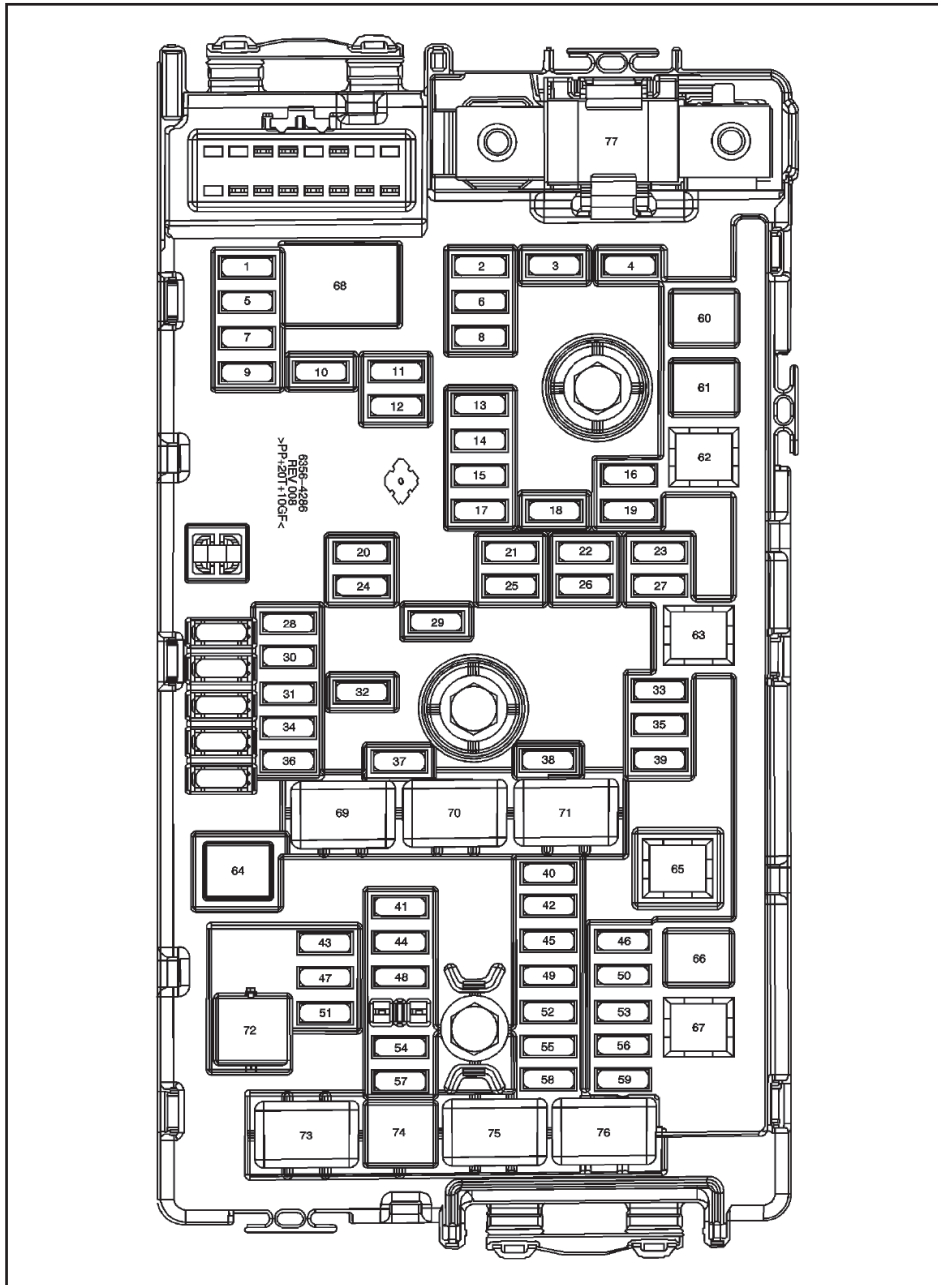

Fuse Block - Underhood - Bottom View

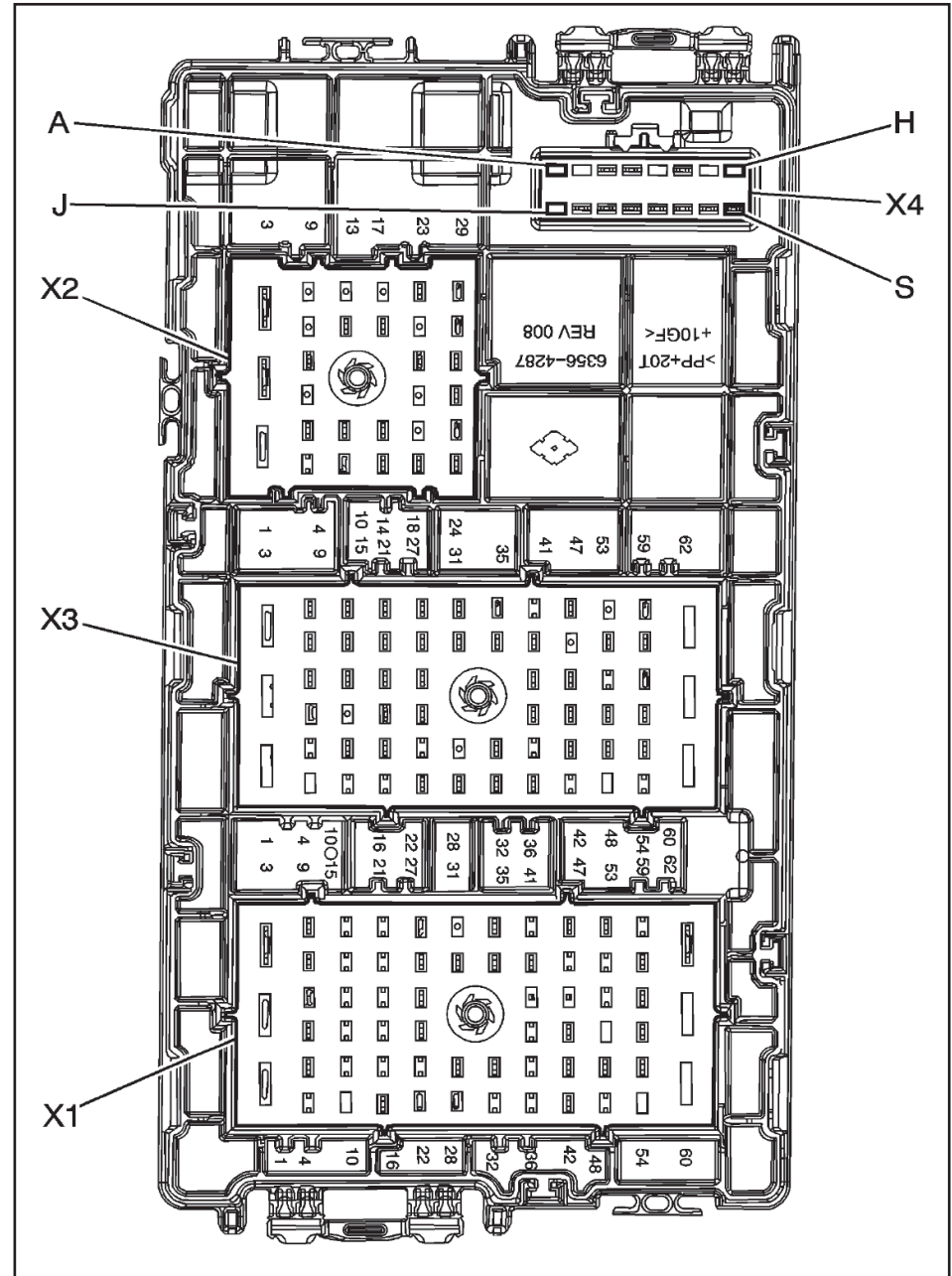

Fuse Block – Underhood – X1

Connector Part Information

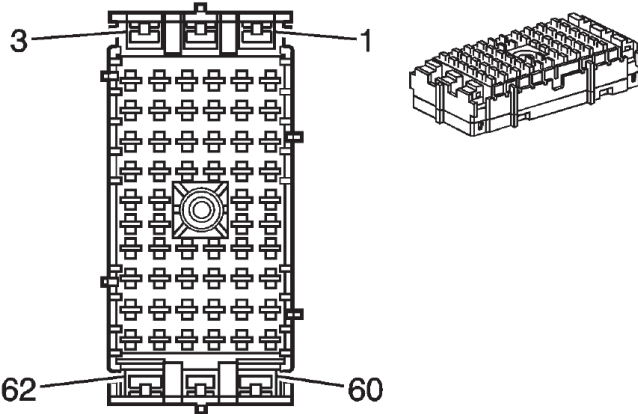

OEM: 13578271

Service: See Catalog

Description: 62-Way F
2.8 Series (BK)

Terminal Part Information

Pins: 1, 3, 62

Terminal/Tray: 7116-4122-02/10

Core/Insulation Crimp: D/G

Release Tool/Test Probe: 12094430/J-35616-42 (RD)

Pins: 5, 7, 8, 16, 22, 26, 28, 35, 40, 42-44, 47, 55, 56, 58

Terminal/Tray: 8100-4443/22

Core/Insulation Crimp: E/A

Release Tool/Test Probe: 15315247/J-35616-35 (VT)

Pins: 6, 9, 29, 30, 33, 34

Terminal/Tray: 8100-4445/22

Core/Insulation Crimp: See Terminal Repair Kit

Release Tool/Test Probe: 15315247/J-35616-35 (VT)

Pins: 24, 25, 44, 49, 53, 57

Terminal/Tray: 8100-4444/22

Core/Insulation Crimp: 2/A

Release Tool/Test Probe: 15315247/J-35616-35 (VT)

Pin	Wire Color	Circuit No.	Function
1	5 PK	1439	Ignition Voltage (Diesel)
2	--	--	Not Used
3	5 RD/BK	542	Battery Positive Voltage
4	--	--	Not Used
5	0.5 PK	1839	Ignition Voltage (4.3L)
6	0.8 PK	1539	Ignition Voltage (Gas)
	0.8 PK	1539	Ignition Voltage (Gas)
7	0.5 PK	439	Ignition Voltage (Diesel)
8	0.5 PK	1339	Ignition Voltage
9	0.8 PK	539	Ignition Voltage (Gas)
	0.8 PK	539	Ignition Voltage (Gas)
10-15	--	--	Not Used
16	0.5 YE	5991	Powertrain Relay Control
17-21	--	--	Not Used
22	0.5 WH/BK	2366	Cooling Fan Clutch Control (Diesel)
23	--	--	Not Used
24	1 PK	1039	Ignition Voltage (4.8L/5.3L/6.0L)
	0.8 PK	1039	Ignition Voltage (4.3L)
25	1 PK	1239	Ignition Voltage (4.8L/5.3L/6.0L)
26	0.5 PK	1939	Ignition Voltage
27	--	--	Not Used
28	0.5 WH	2368	Cooling Fan Clutch Control (Diesel)
29	0.8 PK	1039	Ignition Voltage (4.8L/5.3L/6.0L)
	0.8 PK	1039	Ignition Voltage (4.8L/5.3L/6.0L)
30	0.8 PK	1239	Ignition Voltage (4.8L/5.3L/6.0L)
	0.8 PK	1239	Ignition Voltage (4.8L/5.3L/6.0L)
31-32	--	--	Not Used

Fuse Block – Underhood – X1 (cont'd)

Pin	Wire Color	Circuit No.	Function
33	0.8 PK	1039	Ignition Voltage (4.8L/5.3L/6.0L)
	0.8 PK	1039	Ignition Voltage (4.8L/5.3L/6.0L)
34	0.8 PK	1239	Ignition Voltage (4.8L/5.3L/6.0L)
	0.8 PK	1239	Ignition Voltage (4.8L/5.3L/6.0L)
35	0.5 PK	1939	Ignition Voltage (Gas)
36-39	--	--	Not Used
40	0.5 PK	439	Ignition Voltage
41	--	--	Not Used
42	0.35 D-GN/ WH	459	A/C Compressor Clutch Relay Control (Gas with C60)
	0.5 D-GN/WH	459	A/C Compressor Clutch Relay Control (Diesel with C60)
43	0.5 D-GN/WH	59	A/C Compressor Clutch Supply Voltage (C60)
44	0.5 RD/WH	440	Battery Positive Voltage (Gas)
	1 RD/WH	440	Battery Positive Voltage (Diesel)
45-46	--	--	Not Used
47	0.35 RD/WH	1840	Battery Positive Voltage

Pin	Wire Color	Circuit No.	Function
48	--	--	Not Used
49	1 BK	1250	Ground
50-52	--	--	Not Used
53	0.8 D-GN	29	Horn Control
54	--	--	Not Used
55	0.35 YE/BK	625	Starter Enable Relay Control (Gas)
	0.5 YE/BK	625	Starter Enable Relay Control (Diesel)
56	0.35 D-GN/ WH	465	Fuel Pump Relay Control - Primary (4.8L/5.3L/6.0L)
	0.5 D-GN/WH	465	Fuel Pump Relay Control - Primary (Diesel)
57	0.8 PK	3039	Ignition Voltage
58	0.5 PK	2139	Ignition Voltage
59-61	--	--	Not Used
62	5 PU	6	Starter Solenoid Crank Voltage

Fuse Block - Underhood - X2

Connector Part Information

OEM: 13578275

Service: See Catalog

Description: 29-Way F
2.8 Series (BK)

Terminal Part Information

Pins: 5, 7, 10-13, 15, 18, 23, 26, 28

Terminal/Tray: 8100-4444/22

Core/Insulation Crimp: 2/A

Release Tool/Test Probe: 15315247/J-35616-35 (VT)

Pins: 16, 21

Terminal/Tray: 8100-4443/22

Core/Insulation Crimp: E/A

Release Tool/Test Probe: 15315247/J-35616-35 (VT)

Pins: 1, 3, 2

Terminal/Tray: 7116-4122-02/10

Core/Insulation Crimp: Pins 1, 3 - A/B

Core/Insulation Crimp: Pins 2 - D/G

Release Tool/Test Probe: 12094430/J-35616-42 (RD)

Pins: 14, 23-25

Terminal/Tray: 8100-4445/22

Core/Insulation Crimp: Pins 14 - F/D

Core/Insulation Crimp: Pins 23, 24, 25 - 4/4

Release Tool/Test Probe: 15315247/J-35616-35 (VT)

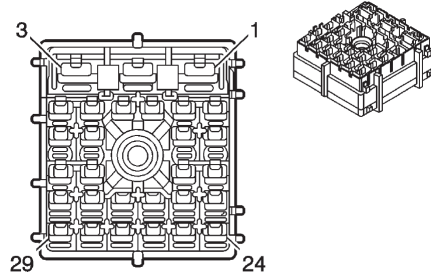

Pin	Wire Color	Circuit No.	Function
6	--	--	Not Used
7	1 L-GN	1624	Trailer Backup Lamps Control (Cutaway/UY7)
8-9	--	--	Not Used
10	1 YE	1618	Trailer Left Rear Turn/Stop Lamp Control (UY7)
11	1 YE	618	Left Rear Turn Signal Lamp Control (Cutaway)
12	1 D-GN	619	Right Rear Turn Signal Lamp Control (Cutaway)
13	0.8 PK	2239	Ignition Voltage (Diesel)
14	3 D-BU	47	Trailer Auxiliary Control (UY7)
15	1 BN	2109	Trailer Park Lamps Control (UY7)
16	0.5 PK	2739	Ignition Voltage (5.3L)
17	--	--	Not Used
18	1 BN	2109	Trailer Park Lamps Control (Cutaway)
19-20	--	--	Not Used
21	0.5 RD/WH	40	Battery Positive Voltage (Gas)
22	--	--	Not Used
23	0.8 GY	120	Fuel Pump Control (6.6L)
	2 GY	120	Fuel Pump Control (4.3L/4.8L/6.0L)
24	2 Rd/WH	1940	Battery Positive Voltage (5.3L)
25	2 RD/WH	1740	Battery Positive Voltage (Diesel with K08)
26	1 L-BU	1320	CHMSL Control/Stop Lamp Control (Cutaway)
27	--	--	Not Used
28	1 D-GN	1619	Trailer Right Rear Turn-Stop Lamp Control (UY7)
29	--	--	Not Used

Pin	Wire Color	Circuit No.	Function
1	3 RD/BK	742	Battery Positive Voltage (UY7)
2	5 RD/BK	442	Battery Positive Voltage
3	3 RD/WH	1640	Battery Positive Voltage
4	--	--	Not Used
5	0.8 D-BU/WH	149	Courtesy Lamp Control (Cutaway)

Fuse Block - Underhood - X3

Connector Part Information

OEM: 13578273

Service: See Catalog

Description: 62-Way F
2.8, 6.3 Series (GY)

Terminal Part Information

Pins: 12, 22, 27, 30, 33, 36,
38-40, 44-47, 50, 54-56, 58

Terminal/Tray: 8100-4443/22

Core/Insulation Crimp: E/A

Release Tool/Test Probe: 15315247/J-35616-35 (VT)

Pins: 6, 18, 28, 32

Terminal/Tray: 8100-4445/22

Core/Insulation Crimp: Pins: 6, 18 - F/D

Core/Insulation Crimp: Pins: 28, 32 - 4/4

Release Tool/Test Probe: 15315247/J-35616-35 (VT)

Pins: 7-9, 11, 13-15, 17, 20, 21, 24-27, 31, 34, 43, 52, 49

Terminal/Tray: 8100-4444/22

Core/Insulation Crimp:

Pins 7-9, 11, 13-15, 17, 20, 21, 24-27, 31, 34, 43, 52-2/A

Core/Insulation Crimp: Pins 49 - See Terminal Repair Kit

Release Tool/Test Probe: 15315247/J-35616-35 (VT)

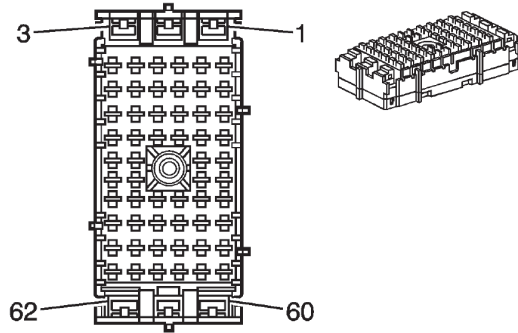

Pin	Wire Color	Circuit No.	Function
1-5	--	--	Not Used
6	3 RD/WH	3940	Battery Positive Voltage (UY7)
7	0.8 RD/WH	1040	Battery Positive Voltage
8	0.8 D-BU/WH	149	Courtesy Lamp Control (Cutaway)
9	0.8 RD/WH	2940	Battery Positive Voltage
10	--	--	Not Used
11	0.8 RD/WH	640	Battery Positive Voltage
12	0.35 OG	5186	Left Trailer Turn Signal Lamp (UY7)

Pin	Wire Color	Circuit No.	Function
13	1 L-GN	1624	Trailer Backup Lamps Control (Cutaway/UF7/8S8)
14	1 YE	618	Left Rear Turn Signal Lamp Control (Cutaway)
15	0.8 RD/WH	2740	Battery Positive Voltage
16	--	--	Not Used
17	0.8 RD/WH	640	Battery Positive Voltage
18	3 D-BU	47	Trailer Auxiliary Control (UY7)
19	0.35 RD/WH	2840	Battery Positive Voltage (8S8)
20	0.8 RD/WH	2240	Battery Positive Voltage
21	0.8 RD/WH	3040	Battery Positive Voltage
22	0.35 GY	91	Windshield Wiper Switch Signal 2
23	--	--	Not Used
24	1 BN	2109	Trailer Park Lamps Control (UY7)
25	0.8 D-BU/WH	1315	Right Front Turn Signal Lamp Control
26	1 BN	2109	Trailer Park Lamps Control (Cutaway)
27	0.5 RD/WH	2540	Battery Positive Voltage
28	2 PU	92	Windshield Wiper Motor High Speed
29	--	--	Not Used
30	0.5 WH	5065	Stop Lamps Control
31	1 D-GN	619	Right Rear Turn Signal Lamp Control (Cutaway)
32	2 D-GN	95	Windshield Washer Switch Signal
33	0.35 OG	2268	Windshield Washer Relay Control
34	0.8 L-BU/WH	1314	Left Front Turn Signal Lamp Control
35	--	--	Not Used

Fuse Block – Underhood – X3 (cont'd)

Pin	Wire Color	Circuit No.	Function
36	0.35 TN	860	Front Windshield Wiper Switch High Signal
37	--	--	Not Used
38	0.5 OG	228	Windshield Washer Pump Control
39	0.35 PK/WH	1970	Headlamp Low Beam Relay Control
40	0.35 PU	544	Headlamp Low Beam Control
41-42	--	--	Not Used
43	0.8 RD/WH	2140	Battery Positive Voltage
44	0.35 TN/WH	1969	Headlamp High Beam Relay Control
45	0.35 PK	239	Ignition Voltage
46	0.35 YE	5187	Right Trailer Turn Signal Lamp (UY7)

Pin	Wire Color	Circuit No.	Function
47	0.5 RD/WH	3840	Battery Positive Voltage
48	--	--	Not Used
49	0.35 TN	28	Horn Relay Control
	0.35 TN	28	Horn Relay Control
50	0.35 PK	1139	Ignition Voltage
51	--	--	Not Used
52	0.8 BN	2309	Front Park Lamps Control
53	--	--	Not Used
54	0.35 YE	5199	Run/Crank Relay Coil Control
55	0.5 PK	2239	Ignition Voltage (JL4)
56	0.35 PK	1139	Ignition Voltage
57	--	--	Not Used
58	0.35 PK	1639	Ignition Voltage
59-62	--	--	Not Used

Fuse Block - Underhood - X4

Connector Part Information
 OEM: 15326952
 Service: 15326952
 Description: 16-Way F
 GT 280 Series (BK)

Terminal Part Information
 Pins: C, D, F, L, M, N, R, K, P, S
 Terminal/Tray: 15304711/8
 Core/Insulation Crimp: Pins C, D, F, L, M, N, R - E/A
 Core/Insulation Crimp: Pins K, P, S - 2/A
 Release Tool/Test Probe: 15315247/J-35616-4A (PU)

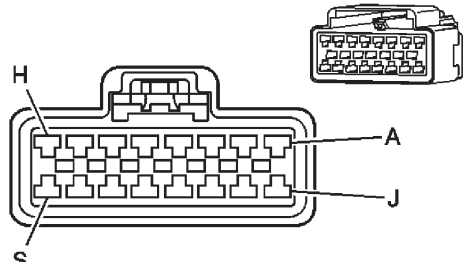

Pin	Wire Color	Circuit No.	Function
A-B	--	--	Not Used
C	0.35 TN/WH	312	Right Headlamp Low Beam Control (without V22)
	0.5 TN/WH	312	Right Headlamp Low Beam Control (V22)
D	0.5 BN	2309	Front Park Lamps Control
E	--	--	Not Used
F	0.35 YE	712	Left Headlamp Low Beam Control
G-J	--	--	Not Used
K	0.8 L-GN/BK	311	Right Headlamp High Beam Control
L	0.5 D-GN/WH	711	Left Headlamp High Beam Control

Pin	Wire Color	Circuit No.	Function
M	0.5 YE	712	Left Headlamp Low Beam Control (V22)
	0.5 YE	712	Left Headlamp Low Beam Control (V22)
	0.35 YE	712	Left Headlamp Low Beam Control (without V22)
	0.35 YE	712	Left Headlamp Low Beam Control (without V22)
N	0.5 BN	2309	Front Park Lamps Control
P	0.8 L-BU/WH	1314	Left Front Turn Signal Lamp Control
R	0.5 YE	712	Left Headlamp Low Beam Control (V22 without T79)
S	0.8 D-BU/WH	1315	Right Front Turn Signal Lamp Control

Fuse Block – Underhood – X5

Terminal Part Information

Terminal: 15441775

Core/Insulation Crimp: N/A

Description: Ring Terminal

Pin	Wire Color	Circuit No.	Function
S	19 RD	1	Battery Positive Voltage

Fuse Blocks - Body - Location View

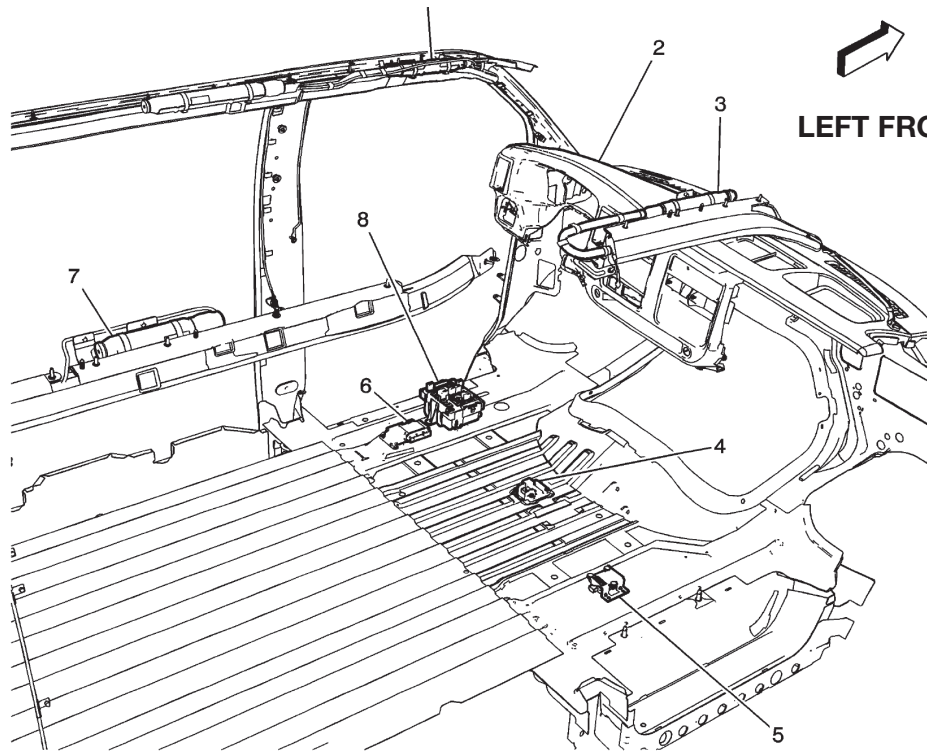

LEFT FRONT SIDE OF PASSENGER COMPARTMENT

- (1) Inflatable Restraint Roof Rail Module - Left Front (ASF)
- (2) Instrument Panel - Upper Pad
- (3) Inflatable Restraint Roof Rail Module - Right Front (ASF)
- (4) Inflatable Restraint Vehicle Rollover Sensor (ASF)
- (5) Yaw and Lateral Accelerometer Sensor (JL4)
- (6) Inflatable Restraint Sensing and Diagnostic Module (SDM)
- (7) Inflatable Restraint Roof Rail Module - Right Rear (ASF with YA2)
- (8) Fuse Block - Body**

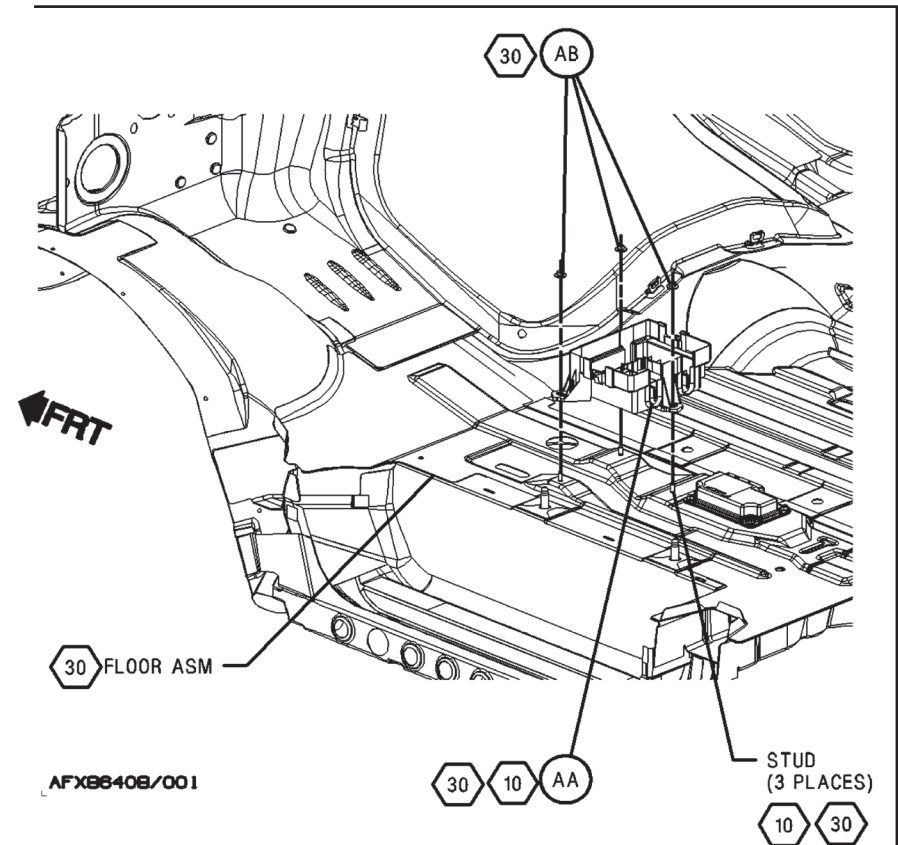

**BODY HARNESS JUNCTION BLOCK
(POWER, DISTRIBUTION CENTER) BODY BEC TO FLOOR**

Fuse Blocks - Body - In-Cab Power Access

Stud: +12V Battery

+12V Ignition

+ 12V Battery

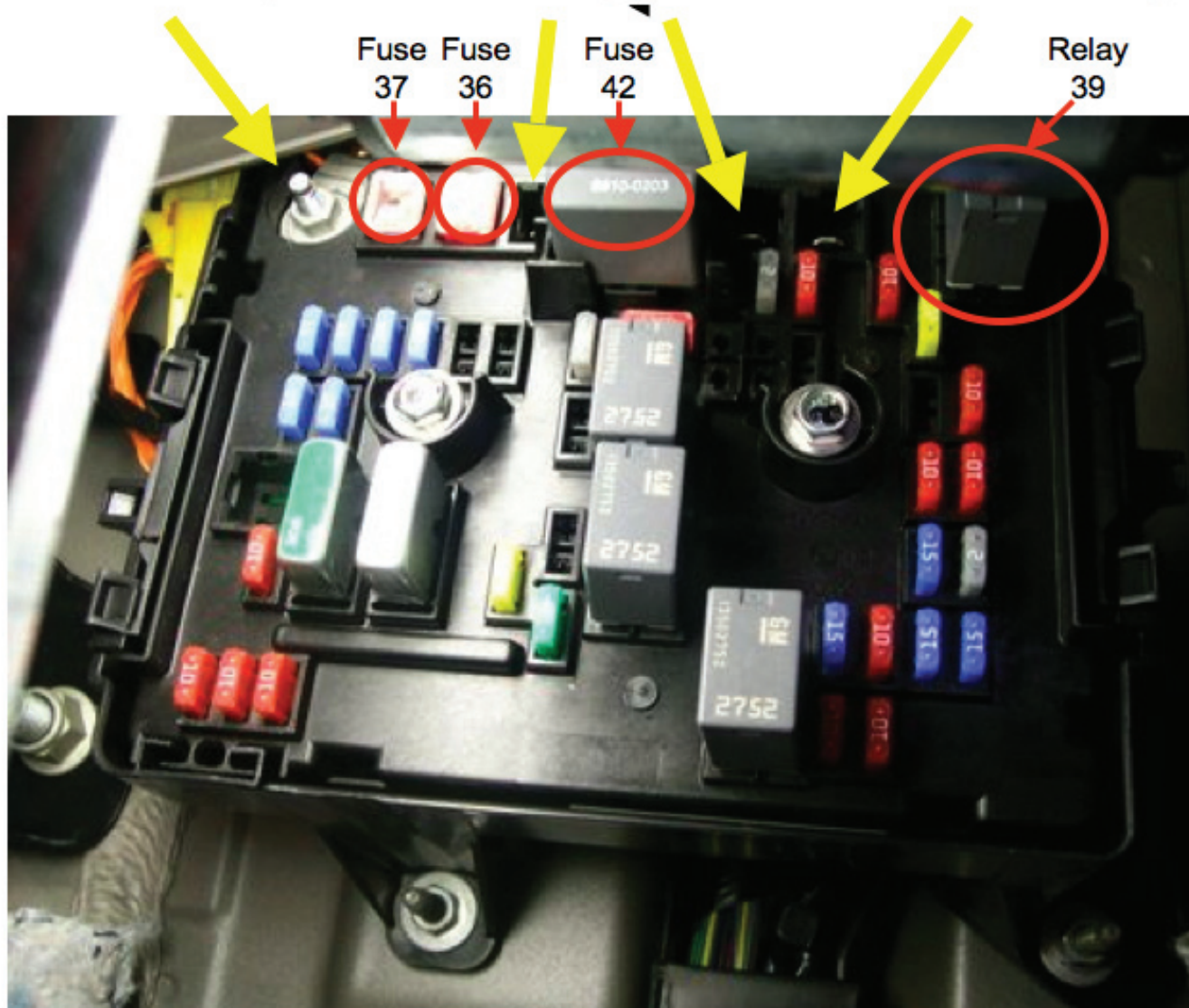

Fuse Blocks - Body - Label Usage

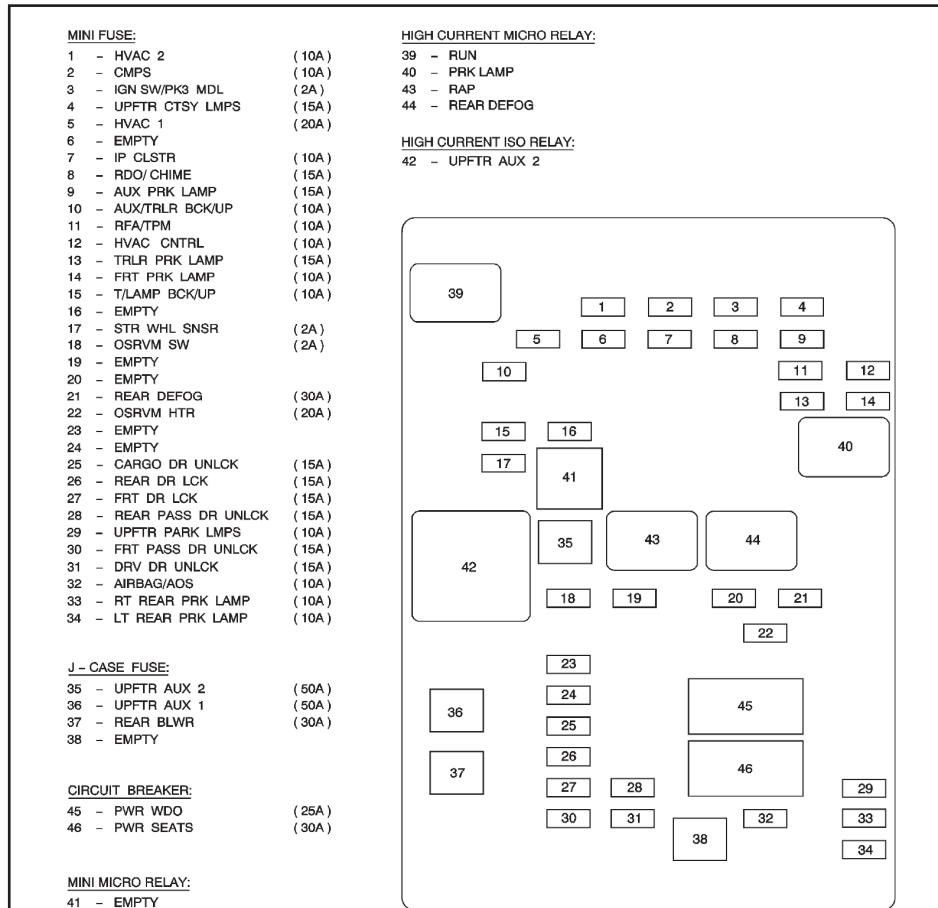

No.	Device	Rating	Description
1	HVAC 2 Fuse	10A	Air Temperature Actuator, HVAC Control Assembly (C49/DE5/DE7), HVAC Control Module - Auxiliary, HVAC Control Assembly - Rear Auxiliary (C69 with Rear Auxiliary Controls), Blower Motor Low Speed Relay - Auxiliary (C36/C69), Blower Motor Medium Speed Relay - Auxiliary (C36/C69), Blower Motor High Speed Relay - Auxiliary (C36/C69), Mode Actuator - Auxiliary (C69) and Air Temperature Actuator - Auxiliary (C69)

No.	Device	Rating	Description
2	CMPS Fuse	10A	Electronic Compass Module (U80)
3	IGN SW/PK3 MDL Fuse	2A	Ignition Switch and Theft Deterrent Module
4	UPFTR CTSY LMPS Fuse	15A	Body Control Module (without YF7), X405 (Cutaway), Dome/Reading Lamp - Middle (Passenger), Dome Lamp (Cargo), Dome/Reading Lamp - Rear (Passenger), X320 (YF7) and Dome/Reading Lamp Front
5	HVAC 1 Fuse	20A	HVAC Control Assembly and Vacuum Pump - Diesel
6	EMPTY	--	Not Used
7	IP CLSTR Fuse	10A	Instrument Panel Cluster
8	RDO/CHIME Fuse	15A	Radio, Chime Module
9	AUX PRK LAMP Fuse	15A	X405 (Cutaway)
10	AUX/TRLR BCK/UP Fuse	10A	Backup Alarm (8S3), Trailer Connector (UY7) and X405 (Cutaway)
11	RFA/TPM Fuse	10A	Remote Control Door Lock Receiver (RCDLR) (AUO)
12	HVAC CNTRL Fuse	10A	HVAC Control Assembly (DE5/DE7/C49)
13	TRLR PRK LAMP Fuse	15A	Trailer Connector (UY7)
14	FRT PRK LAMP Fuse	10A	Park/Turn Signal Lamp - LF, Marker Lamp - LF, Park/Turn Signal Lamp - RF, Marker Lamp - RF and inflatable Restraint I/P Module Disable Switch (C99)
15	T/LAMP BCK/UP Fuse	10A	Backup Lamp - Right (Passenger/Cargo) and Backup Lamp - Left (Passenger/Cargo)
16	EMPTY	--	Not Used
17	STR WHL SNSR Fuse	2A	Inflatable Restraint Steering Wheel Module Coil (K34/W1Y)

Fuse Blocks - Body - Label Usage (cont'd)

No.	Device	Rating	Description
18	OSRVM SW Fuse	2A	Outside Rearview Mirror Switch (DE5/DE7)
19	EMPTY	--	Not Used
20	EMPTY	--	Not Used
21	REAR DEFOG Fuse	30A	Rear Window Defogger Grid - Left (C49) and Rear Window Defogger Grid - Right (C49)
22	OSRVM HTR Fuse	20A	Outside Rearview Mirror - Driver (DE5/DE7) and Outside Rearview Mirror - Passenger (DE5/DE7)
23	EMPTY	--	Not Used
24	EMPTY	--	Not Used
25	CARGO DR UNLCK Fuse	15A	Door Latch Assembly - Cargo (Passenger/Cargo with AU3)
26	REAR DR LCK Fuse	15A	Door Contact Plate Left Side (D26), Door Contact Plate - Right Side (E24/YA2) and Door Latch Assembly - Cargo (Passenger/Cargo)
27	FRT DR LCK Fuse	15A	Door Latch Assembly - Driver (AU3) and Door Latch Assembly - Passenger (AU3)
28	REAR PASS DR UNLCK Fuse	15A	Door Contact Plate - Left Side (E26/AU3), Door Contact Plate - Right Side (Passenger/Cargo with AU3) and Fuse Block - Body
29	UPFTR PARK LAMPS Fuse	10A	X320 (YF2/YF7)
30	FRT PASS DR UNLCK Fuse	15A	Door Latch Assembly - Passenger (AU3)
31	DRV DR UNLCK Fuse	15A	Door Latch Assembly - Driver (AU3)
32	AIRBAG/AOS Fuse	10A	Inflatable Restraint Sensing and Diagnostic Module (SDM), inflatable Restraint Vehicle Rollover Sensor (ASF) and inflatable Restraint Front Passenger Presence System (PPS) Sensor (Light Duty without YF7)

No.	Device	Rating	Description
33	RT REAR PRK LAMP Fuse	10A	Tail/Stop and Turn Signal Lamp - Right (Passenger/Cargo)
34	LT REAR PRK LAMP Fuse	10A	Tail/Stop and Turn Signal Lamp - Left (Passenger/Cargo) and, License Lamp (Passenger/Cargo)
35	UPFTR AUX 2 Fuse	50A	Blunt Cut (YF1), X321 (YF2/YF7) and X222 (YF2/YF7)
36	UPFTR AUX 1 Fuse	50A	Blunt Cut (YF1), X321 (YF2/Y7) and X222 (YF2/YF7)
37	REAR BLWR Fuse	30A	Blower Motor Low Speed Relay - Auxiliary (C36/C69), Blower Motor Medium Speed Relay - Auxiliary (C36/C69) and Blower Motor High Speed Relay - Auxiliary (C36/C69)
38	EMPTY	--	Not Used
39	RUN Relay	--	HVAC 1, HVAC 2, CMPS Fuses and UPFTR AUX 2 Relay
40	PRK LAMP Relay	--	LT REAR PRK LAMP, RT REAR PRK LAMP, FRT PRK LAMP, TRLR PRK LAMP, AUX PRK LAMP and UPFTR PARK LMPS Fuses
41	EMPTY	--	Not Used
42	UPFTR AUX 2 Relay	--	UPFTR AUX 2 Fuse
43	RAP Relay	--	PWR WDO Circuit Breaker
44	REAR DEFOG Relay	--	REAR DEFOG and OSRVM HTR Fuses
45	PWR WDO Circuit Breaker	25A	Window Switch - Driver (A31) and Window Switch - Passenger (A31)
46	PWR SEATS Circuit Breaker	30A	Seat Adjuster Switch - Driver (AG1) and Seat Adjuster Switch - Passenger (AG1)

Fuse Blocks – Body – Label Usage (cont'd)

No.	Device	Rating	Description
IMPORTANT Relays listed below are non-serviceable Printed Circuit Boards (PCB) relays and are internal to the block.			
--	UPFTR CTSY LAMPS PCB Relay	--	UPFTR CTSY LMPS Fuses
--	DRV UNLCK PCB Relay	--	DRV DR UNLCK Fuse
--	PASS/CGO UNLCK PCB Relay	--	FRT PASS DR UNLCK and REAR PASS DR UNLCK Fuses
--	CARGO UNLCK PCB Relay	--	CARGO DR UNLCK Fuse
--	ALL DRS LOCK PCB Relay	--	FRT DR LCK and REAR DR LCK Fuses
--	BCK/UP LAMP PCB Relay	--	AUX/TRLR BCK/UP and T/LAMP BCK UP Fuses

Fuse Block - Body - Top View

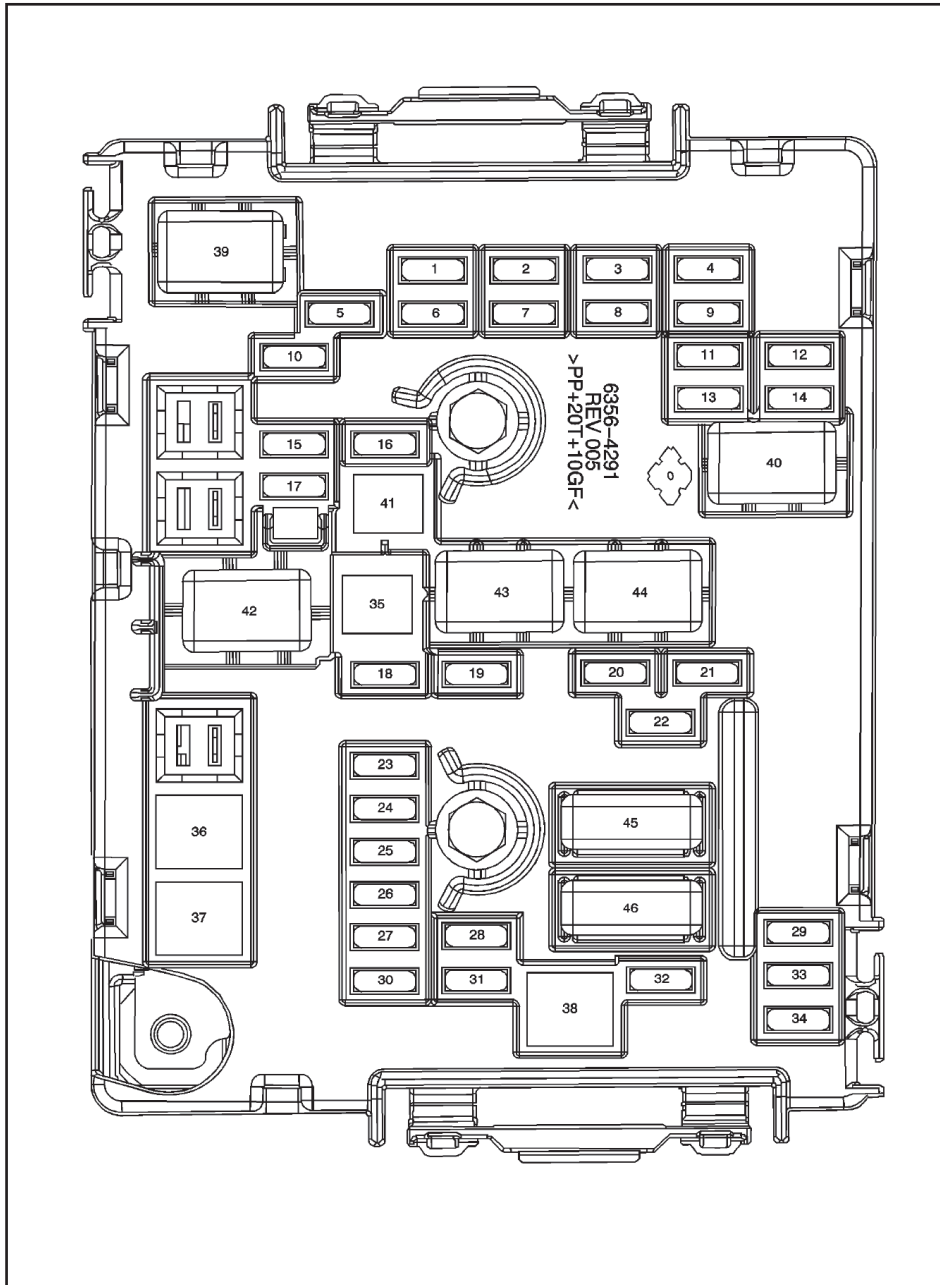

Fuse Block - Body - Bottom View

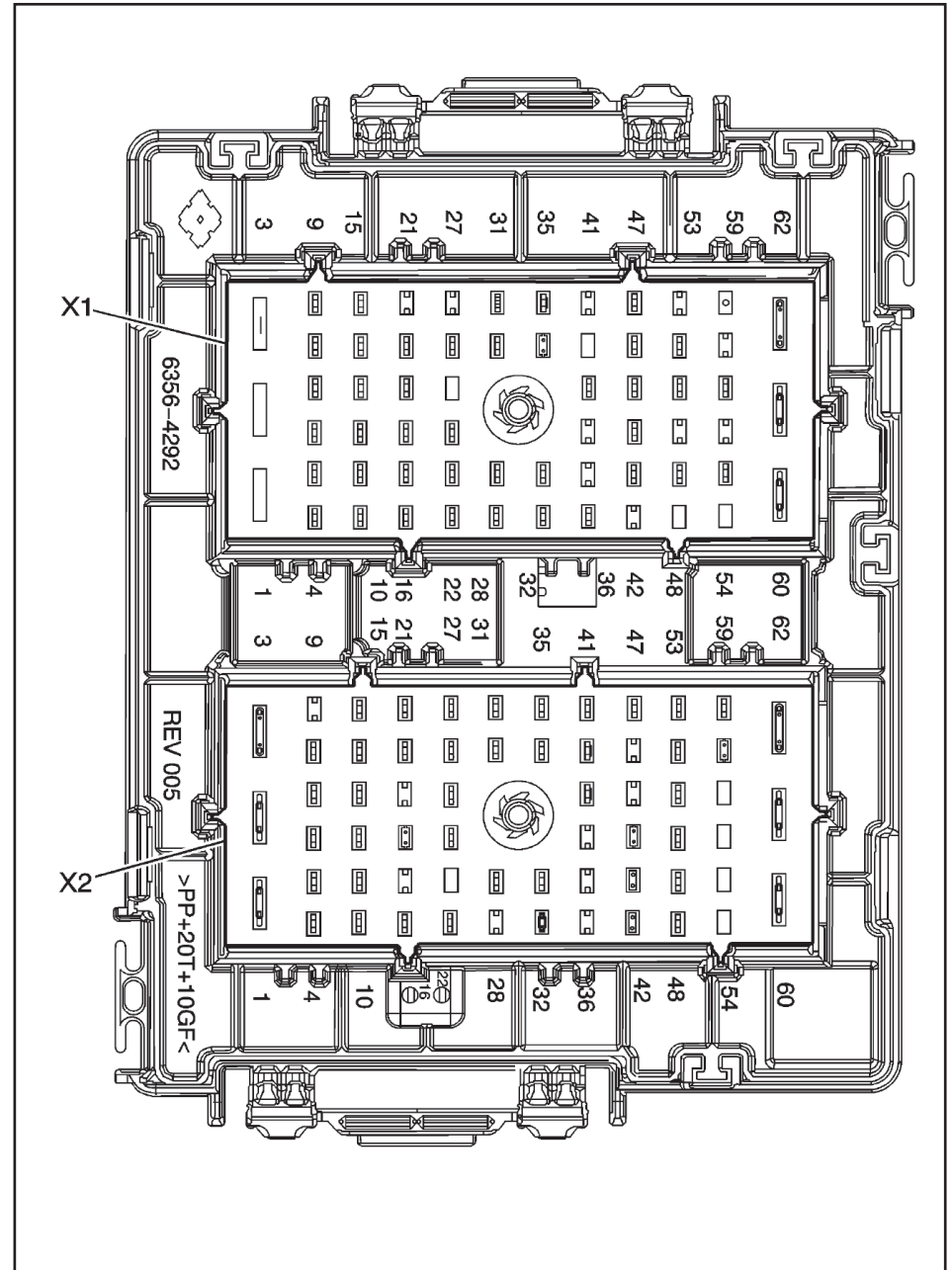

Fuse Block – Body – X1

Connector Part Information

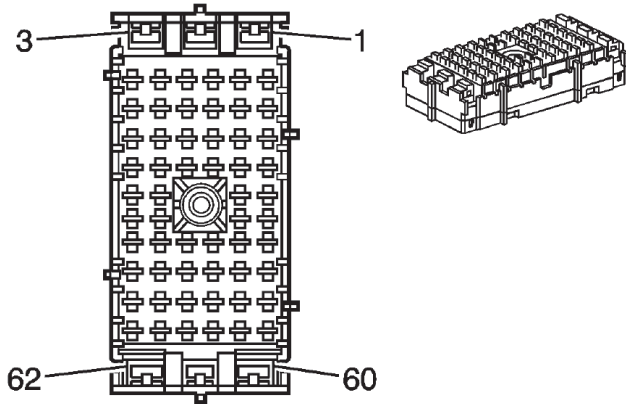

OEM: 13578271

Service: See Catalog

Description: 62-Way F
2.8 Series (BK)

Terminal Part Information

Pins: 60, 61

Terminal/Tray: 7116-4122-02/10

Core/Insulation Crimp: D/G

Release Tool/Test Probe: 12094430/J-35616-42 (RD)

Pins: 4-6, 8, 11, 14, 18-20, 22, 24, 28, 30, 31, 33, 34, 49, 55, 57, 59

Terminal/Tray: 8100-4443/22

Core/Insulation Crimp: E/A

Release Tool/Test Probe: 15315247/J-35616-35 (VT)

Pins: 7, 9, 13, 15, 16, 23, 26, 29, 32, 46, 47, 52

Terminal/Tray: 8100-4444/22

Core/Insulation Crimp: 2/A

Release Tool/Test Probe: 15315247/J-35616-35 (VT)

Pins: 11, 12

Terminal/Tray: 8100-4445/22

Core/Insulation Crimp: See Terminal Repair Kit

Release Tool/Test Probe: 15315247/J-35616-35 (VT)

Pin	Wire Color	Circuit No.	Function
1-3	--	--	Not Used
4	0.35 WH	193	Rear Defog Relay Control (C49/DE5/DE7)
5	0.5 L-BU	244	Passenger Door Lock Switch Lock Control (AU3)
6	0.35 D-BU	45	Park Lamp Control
7	1 BN	2109	Trailer Park Lamps Control (UY7)
8	0.5 RD/WH	5340	Battery Positive Voltage (AU0/UJ6)
9	1 BN	2109	Trailer Park Lamps Control (Cutaway)
10	--	--	Not Used
11	0.5 YE	356	Driver Door Lock Relay Unlock Control (AU3)
	0.5 YE	356	Driver Door Lock Relay Unlock Control (AU3 with PRP)
12	0.5 BN	2309	Front Park Lamps Control
	0.8 BN	2309	Front Park Lamps Control (C99)
13	0.8 D-BU/WH	149	Courtesy Lamp Control (Cutaway)
	0.8 D-BU/WH	149	Courtesy Lamp Control (without YF2/YF7)
14	0.35 RD/WH	540	Battery Positive Voltage
15	1 RD/WH	340	Battery Positive Voltage
16	1 YE	618	Left Rear Turn Signal Lamp Control (Passenger/Cargo)
17	--	--	Not Used
18	0.5 L-BU	244	Passenger Door Lock Switch Lock Control (AU3)
19	0.5 YE	356	Driver Door Lock Relay Unlock Control (AU3)

Fuse Block – Body – X1 (Cont'd)

No.	Device	Rating	Description
20	0.5 GY/BK	690	Courtesy Lamp Control (YF2/YF7)
21	--	--	Not Used
22	0.5 BK	350	Ground
23	0.8 D-BU/WH	1315	Right Front Turn Signal Lamp Control (DE5/DE7)
24	0.35 BK/WH	351	Ground
25	--	--	Not Used
26	0.8 RD/WH	4440	Battery Positive Voltage (C49/DE5/DE7)
27	--	--	Not Used
28	0.35 YE	43	Ignition Voltage
29	1 D-GN	619	Right Rear Turn Signal Lamp Control (Passenger/Cargo)
30	0.35 BN	341	Ignition Voltage
31	0.35 RD/WH	2840	Battery Positive Voltage (without 8S8)
32	0.8 L-BU/WH	1314	Left Front Turn Signal Lamp Control (DE5/DE7)
33	0.35 BN/WH	230	Instrument Panel Lamps Dimming Control
34	0.35 BN	341	Ignition Voltage

No.	Device	Rating	Description
35 -45	--	--	Not Used
46	1 BN	141	Ignition Voltage
47	0.8 BN	141	Ignition Voltage (Diesel)
48	--	--	Not Used
49	0.35 YE	6817	LED Backlight Dimming Control (K34/W1Y)
50 -51	--	--	Not Used
52	1 L-GN	1624	Trailer Backup Lamps Control (Cutaway/UY7/8S3)
53 -54	--	--	Not Used
55	0.35 BN	6136	Supply Voltage (K34/W1Y)
56	--	--	Not Used
57	0.35 D-BU	38	Backup Lamp Relay Control
58	--	--	Not Used
59	0.35 OG	300	Ignition Voltage
60	5 BN	541	Ignition Voltage (YF2/YF7)
61	5 RD/BK	1042	Battery Positive Voltage (YF7)
62	--	--	Not Used

Fuse Block - Body - X2

Connector Part Information

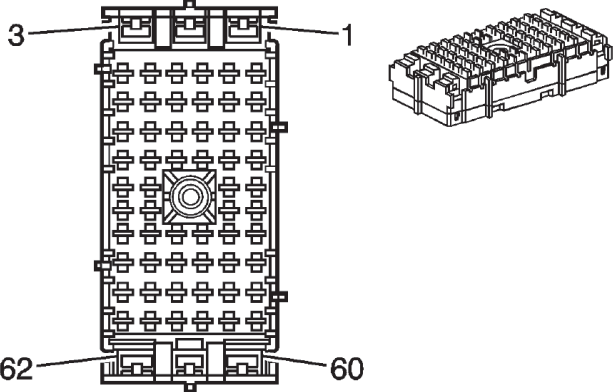

OEM: 13578273
 Service: See Catalog
 Description: 62-Way F
 2.8 , 6.3 Series (GY)

Terminal Part Information

Pins: 2, 3, 60-62
 Terminal/Tray: 7116-4122-02/10
 Core/Insulation Crimp: D/G
 Release Tool/Test Probe: 12094430/J-35616-42 (RD)

Pins: 4, 6, 10, 16, 18, 22, 25-27, 29, 30, 34, 41, 47, 51, 52
 Terminal/Tray: 8100-4443/22
 Core/Insulation Crimp: E/A
 Release Tool/Test Probe: 15315247/J-35616-35 (VT)

Pins: 7, 8, 14, 15, 24, 31-33, 43, 44, 48-50
 Terminal/Tray: 8100-4444/22
 Core/Insulation Crimp: 2/A
 Release Tool/Test Probe: 15315247/J-35616-35 (VT)

Pins: 5, 11-13, 7, 32, 42, 43, 53
 Terminal/Tray: 8100-4445/22
 Core/Insulation Crimp: Pins: 5, 11, 12, 13 - F/D
 Core/Insulation Crimp: 7, 32, 42, 43, 53 - See Terminal Repair Kit
 Release Tool/Test Probe: 15315247/J-35616-35 (VT)

Pin	Wire Color	Circuit No.	Function
1	--	--	Not Used
2	5 PU	293	Rear Defog Element Control (C49)
3	5 PU	293	Rear Defog Element Control (C49)
4	0.5 BN	2609	Right Rear Park Lamps Control (Passenger/Cargo)
5	3 RD/WH	3540	Battery Positive Voltage (AG1)
6	0.5 BN	2209	Rear Park Lamps Control (YF2/YF7)
7	0.8 D-BU/WH	149	Courtesy Lamp Control (Passenger)
	0.8 D-BU/WH	149	Courtesy Lamp Control (Passenger/Cargo without YF2/YF7)
8	1 TN	294	Door Lock Actuator Unlock Control (Passenger/Cargo with AU3)
9	--	--	Not Used
10	0.5 RD/WH	3440	Battery Positive Voltage
11	3 RD/WH	3540	Battery Positive Voltage (AG2)
12	3 D-GN	1001	RAP 12-Volt Fuse Control (A31)
13	3 D-GN	1001	RAP 12-Volt Fuse Control (A31)
14	0.8 OG	2267	Mirror Heating Element Control (DE5/DE7)
15	0.8 OG	2267	Mirror Heating Element Control (DE5/DE7)
16	0.5 RD/WH	3440	Battery Positive Voltage (ASF)
17	--	--	Not Used
18	0.5 D-BU/WH	149	Courtesy Lamp Control
19-21	--	--	Not Used
22	0.5 RD/WH	3440	Battery Positive Voltage (Light Duty without C99/without YF7)
23	--	--	Not Used

Fuse Block – Body – X2 (cont'd)

Pin	Wire Color	Circuit No.	Function
24	1 YE	618	Left Rear Turn Signal Lamp Control (Passenger/Cargo)
25	0.35 BN	441	Ignition Voltage
26	0.35 BN	341	Ignition Voltage (C69/C36/ENC)
27	0.5 D-BU/WH	1315	Right Front Turn Signal Lamp Control (DE5/DE7)
28	--	--	Not Used
29	0.5 BN	2509	Left Rear Park Lamps Control (Passenger/Cargo)
30	0.35 BN	341	Ignition Voltage (C49/DE5/DE7/C60)
31	1 D-GN	619	Right Rear Turn Signal Lamp Control (Passenger/Cargo)
32	0.8 TN	294	Door Lock Actuator Unlock Control (AU3 with E24/YA2)
	0.8 TN	294	Door Lock Actuator Unlock Control (AU3 with E24/YA2)
33	0.8 TN	694	Driver Door Lock Actuator Unlock Control (AU3)
34	0.35 BK/WH	351	Ground
35-40	--	--	Not Used
41	0.5 L-BU/WH	1314	Left Front Turn Signal Lamp Control (DE5/DE7)
42	1 GY	295	Door Lock Actuator Lock Control (AU3)
	1 GY	295	Door Lock Actuator Lock Control (AU3)
43	1 GY	295	Door Lock Actuator Lock Control (AU3 with E26)
	1 GY	295	Door Lock Actuator Lock Control (AU3 with E26/YA2)

Pin	Wire Color	Circuit No.	Function
44	1 TN/BK	1095	Right Rear Door Lock Actuator Unlock Control (Passenger/Cargo with AU3)
45-46	--	--	Not Used
47	0.5 RD/WH	4340	Battery Positive Voltage (DE5/DE7)
48	0.8 TN	294	Door Lock Actuator Unlock Control (AU3)
49	1 GY	295	Door Lock Actuator Lock Control (Passenger/Cargo with AU3)
50	1 TN	294	Door Lock Actuator Unlock Control (Passenger/Cargo with AU3)
51	0.35 BN	341	Ignition Voltage (C69)
52	0.35 BN/WH	230	Instrument Panel Lamps Dimming Control
53	0.8 L-GN	24	Backup Lamp Control (Passenger/Cargo)
	0.8 L-GN	24	Backup Lamp Control (Passenger/Cargo)
54-59	--	--	Not Used
60	5 RD/WH	1740	Battery Positive Voltage (C69/C36/ENC)
61	5 RD/BK	1042	Battery Positive Voltage (YF1/YF2/YF7)
62	5 BN	541	Ignition Voltage (YF1/YF2/YF7)

Fuse Blocks – Rear (PRP) – Location View

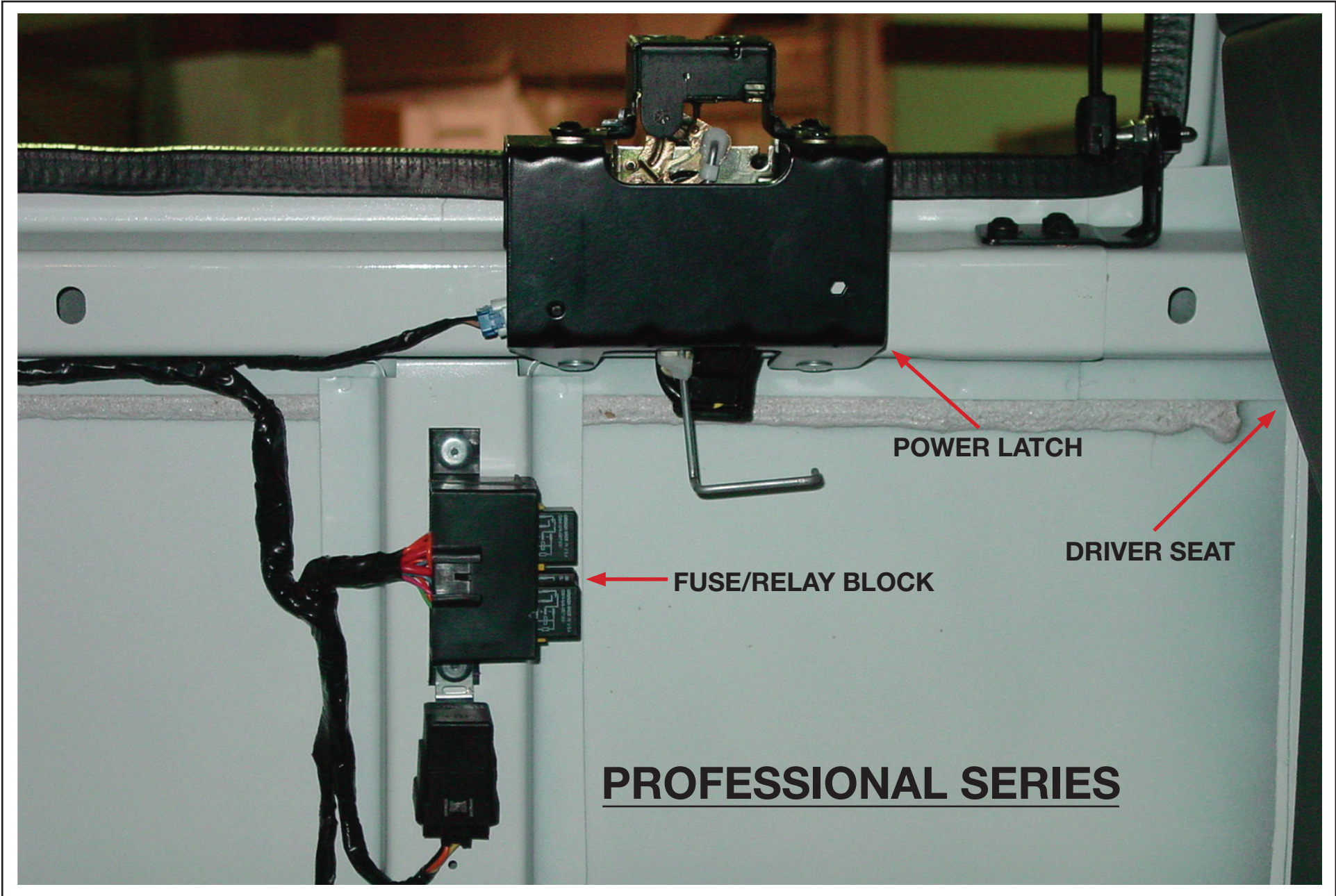

Fuse Block – Rear (PRP) – Top View

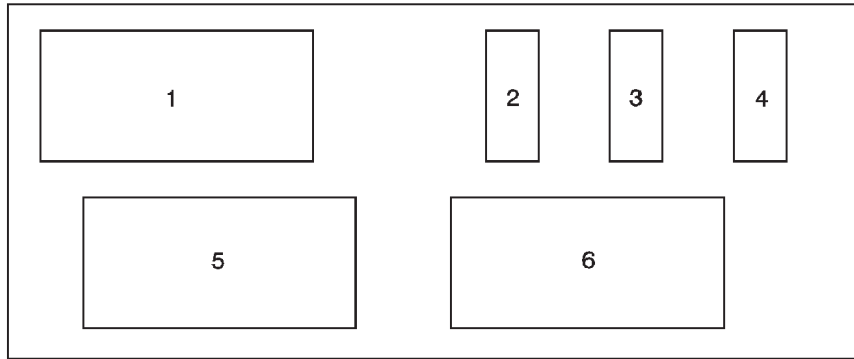

No.	Device	Rating	Description
1	Access Panel Relay - Left Side Rear	--	Access Panel Latches - Left Side Rear
2	Dome Fluorescent Work Lamps Fuse	10A	Dome Fluorescent Work lamps (UF2)
3	Panel Actuator Fuse	15A	Access Panel Relays
4	--	--	Not Used
5	Access Panel Relay - Left Side Front	--	Access Panel Latches - Left Side Front
6	Access Panel Relay - Right Side	--	Access Panel Latches - Right Side

Fuse Block – Rear (PRP) – Bottom View

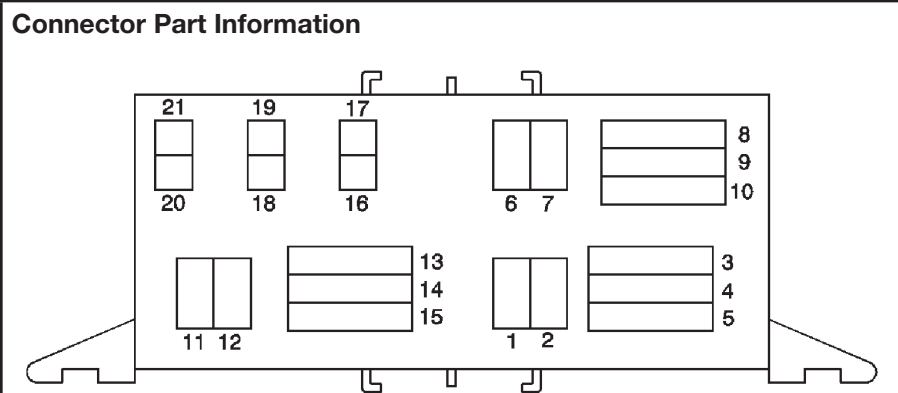

OEM: 63995

Service: See Catalog

Description: 62-Way F
2.8 , 6.3 Series (GY)

Terminal Part Information

Pins: 2, 3, 60-62

Terminal/Tray: 7116-4122-02/10

Core/Insulation Crimp: D/G

Release Tool/Test Probe: 12094430/J-35616-42 (RD)

Pin	Wire Color	Circuit No.	Function
8	L-GN	1391	Access Panel Left Side Rear Relay Control
9	--	--	Not Used
10	OG	740	Battery Positive Voltage
11	OG	740	Battery Positive Voltage
12	TN/BK	1095	Access Panel Right Side Lock Actuators Unlock Control
13	L-BU	1344	Access Panel Right Side Relay Control
14	--	--	Not Used
15	OG	740	Battery Positive Voltage
16	RD	1042	Battery Positive Voltage (UF2)
17	OG	840	Battery Positive Voltage (UF2)
18	RD	1042	Battery Positive Voltage
19	OG	740	Battery Positive Voltage
20-21	--	--	Not Used

Pin	Wire Color	Circuit No.	Function
1	OG	740	Battery Positive Voltage
2	TN	294	Access Panel Left Front Side Lock Actuators Unlock Control
3	L-BU	195	Access Panel Left Side Front Relay Control
4	--	--	Not Used
5	OG	740	Battery Positive Voltage
6	OG	740	Battery Positive Voltage
7	PK	1092	Access Panel Left Rear Side Lock Actuators Unlock Control

Switches – A/C Low Pressure Switch – Location View

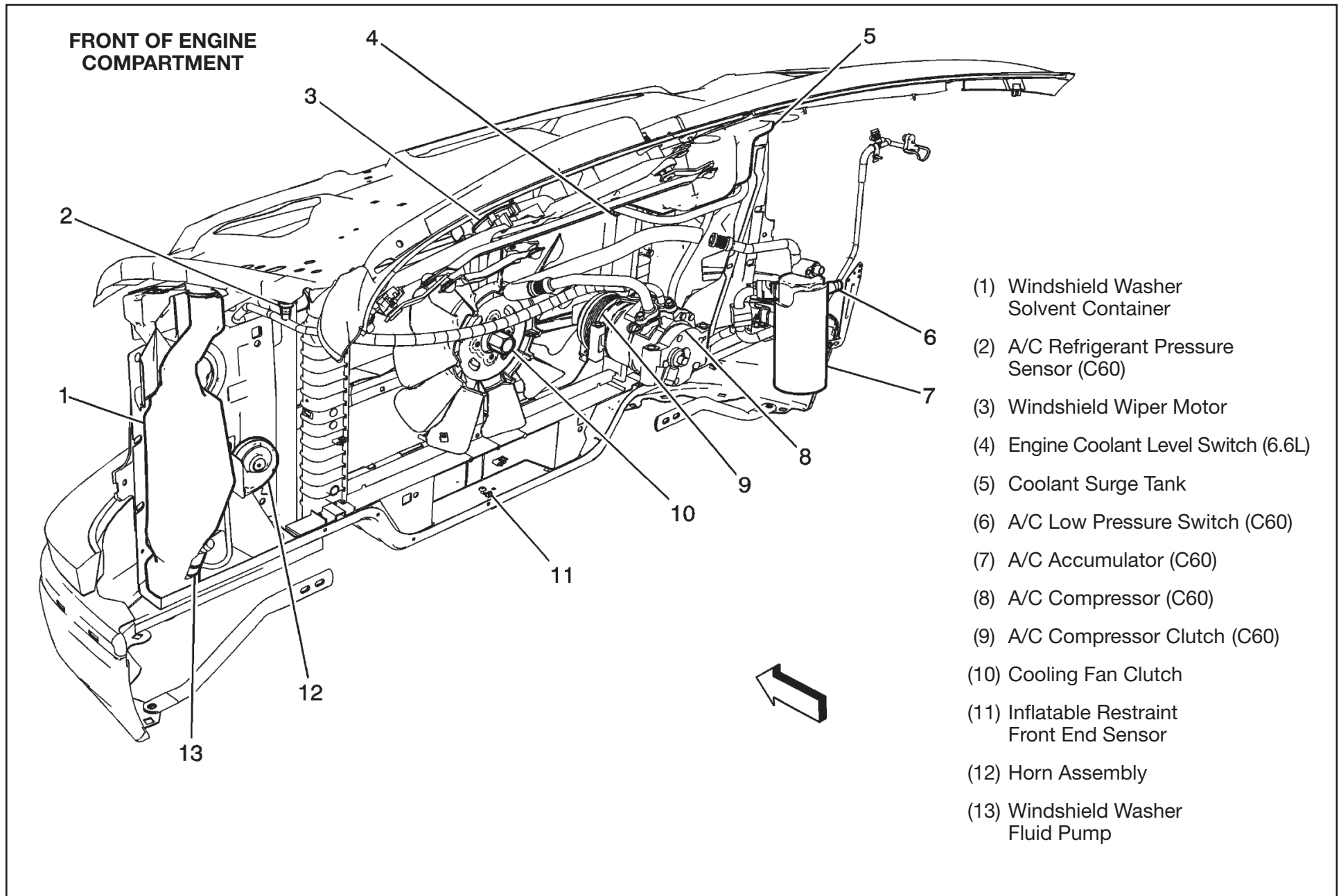

Switches – A/C Low Pressure Switch (C60)

Connector Part Information

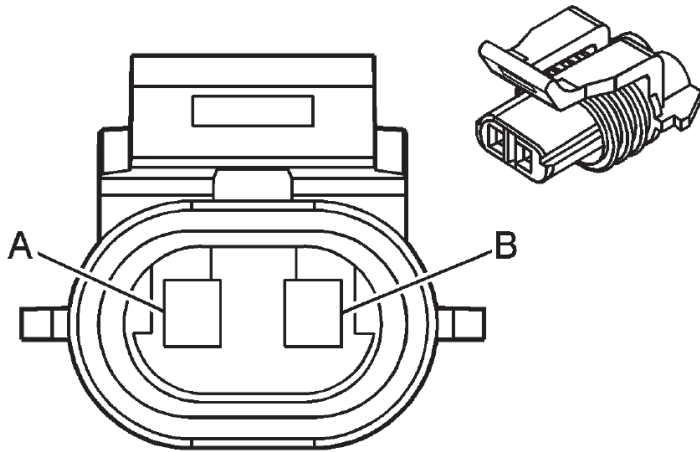

OEM: 12052644

Service: 12052644

Description: 2-Way F
Metri-Pack 150 Series Sealed (GY)

Terminal Part Information

Terminal/Tray: 12048074/2

Core/Insulation Crimp: E/1

Release Tool/Test Probe: 12094429/J-35616-14 (GN)

Pin	Wire Color	Circuit No.	Function
A	0.5 L-GN	66	A/C Request Signal
B	0.5 L-GN	66	A/C Request Signal

Switches – Ignition Switch – Location View

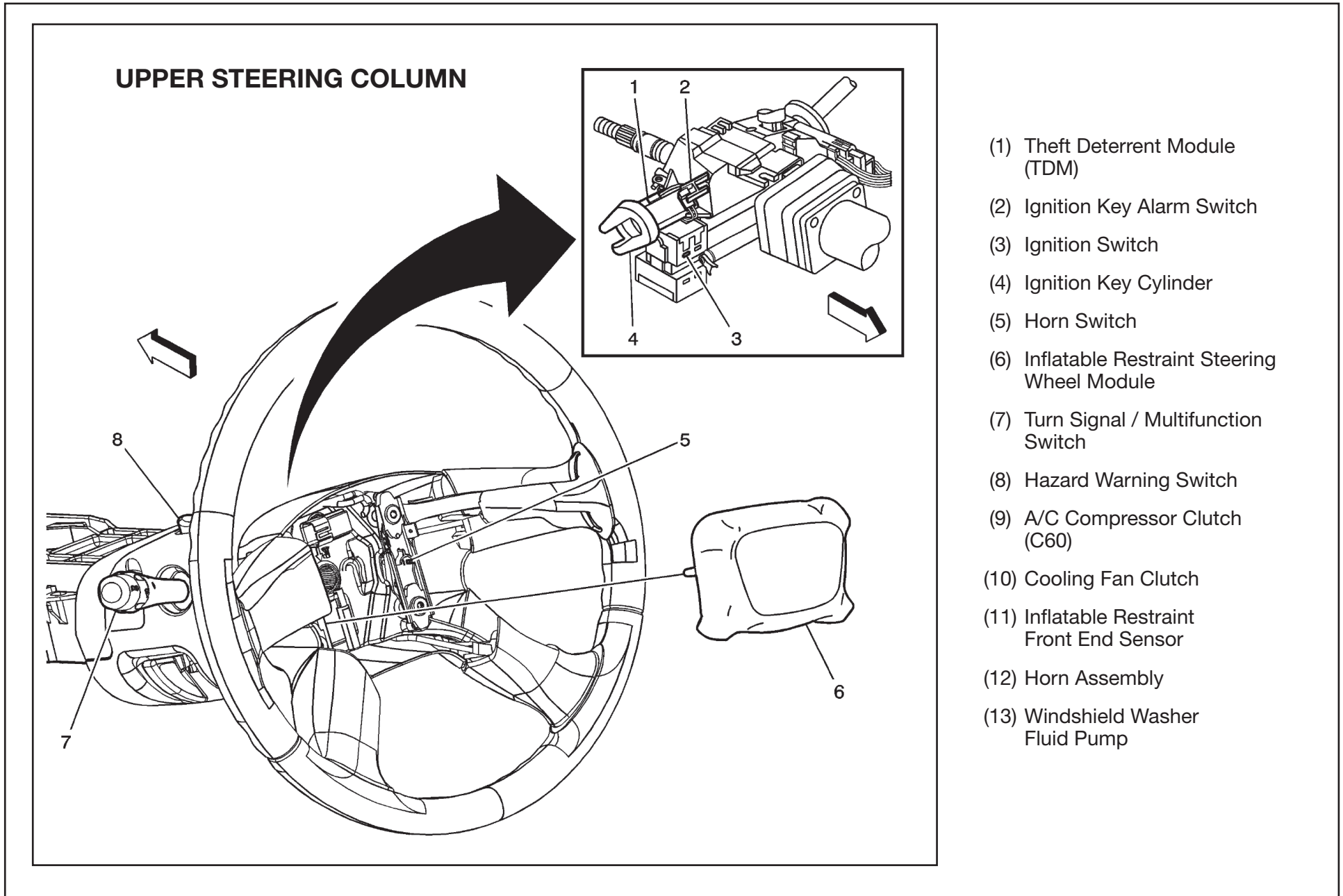

Switches – Ignition Switch – Connector End View

Connector Part Information

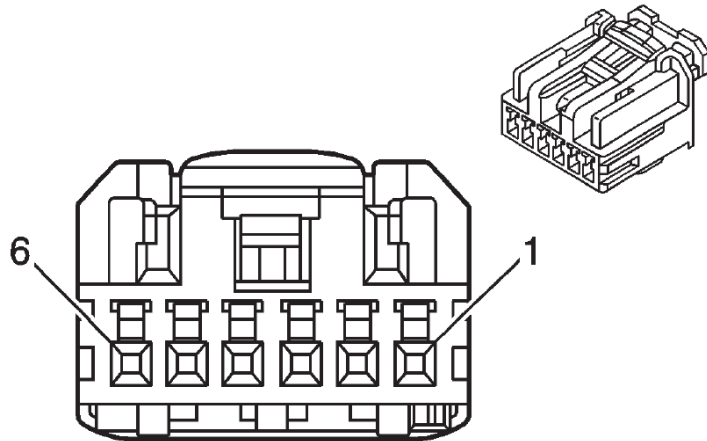

OEM: 15484551

Service: See Catalog

Description: 6-Way F HCM Series (BK)

Terminal Part Information

Pins: 2-6

Terminal/Tray: SCHM-A03T-P025/20

Core/Insulation Crimp: J/J

Release Tool/Test Probe: 12094429/J-35616-64B (L-BU)

Pin	Wire Color	Circuit No.	Function
1	--	--	Not Used
2	0.35 Pk	3	Ignition Voltage
3	0.35 BN	4	Ignition Voltage
4	0.35 RD/H	540	Battery Positive Voltage
5	0.35 PK	1020	Ignition Voltage
6	0.35 WH	530	Ignition Voltage

Switches - Park Brake Switch - Location View

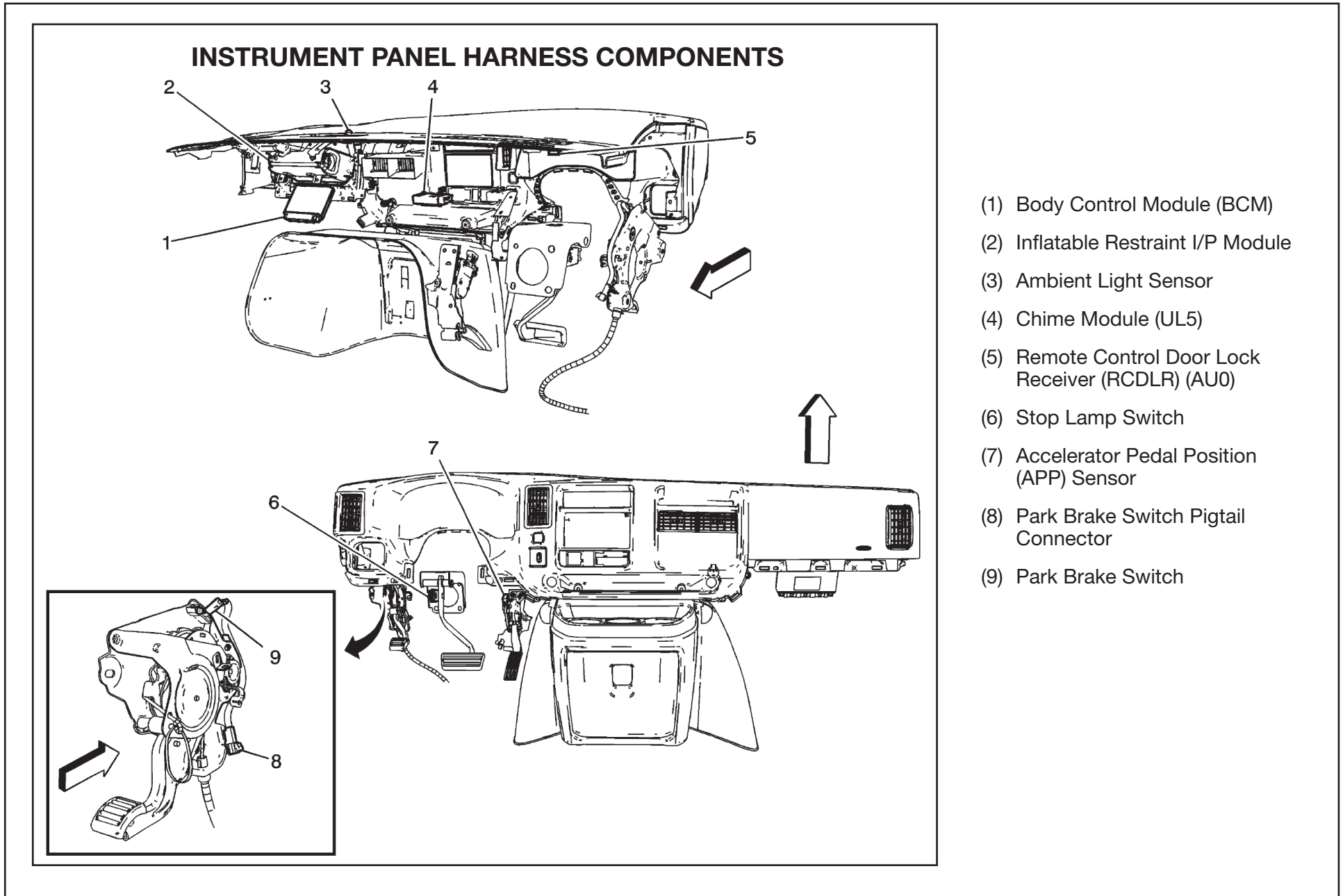

Switches – Park Brake Switch – Connector End View

Connector Part Information

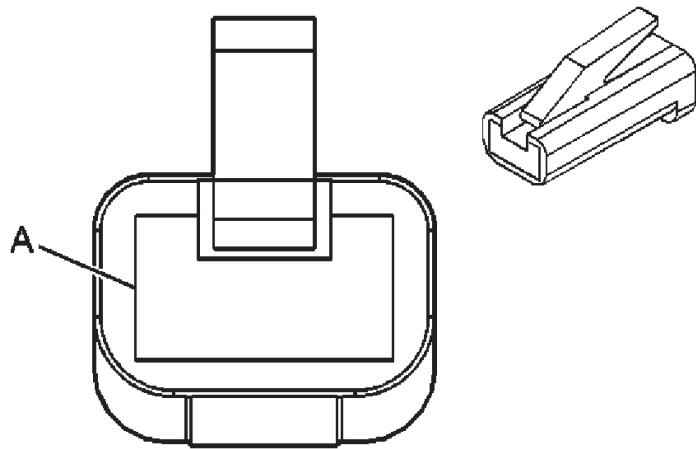

OEM: 12004267

Service: 12004267

Description: 1-Way F 56 Series Lock Type (GY)

Terminal Part Information

Terminal/Tray: See Terminal Repair Kit

Core/Insulation Crimp: See Terminal Repair Kit

Release Tool/Test Probe: See Terminal Repair Kit

Pin	Wire Color	Circuit No.	Function
A	0.5 L-BU	1134	Park Brake Switch Signal

Switches - Park Neutral Position (PNP) Switch - Location View

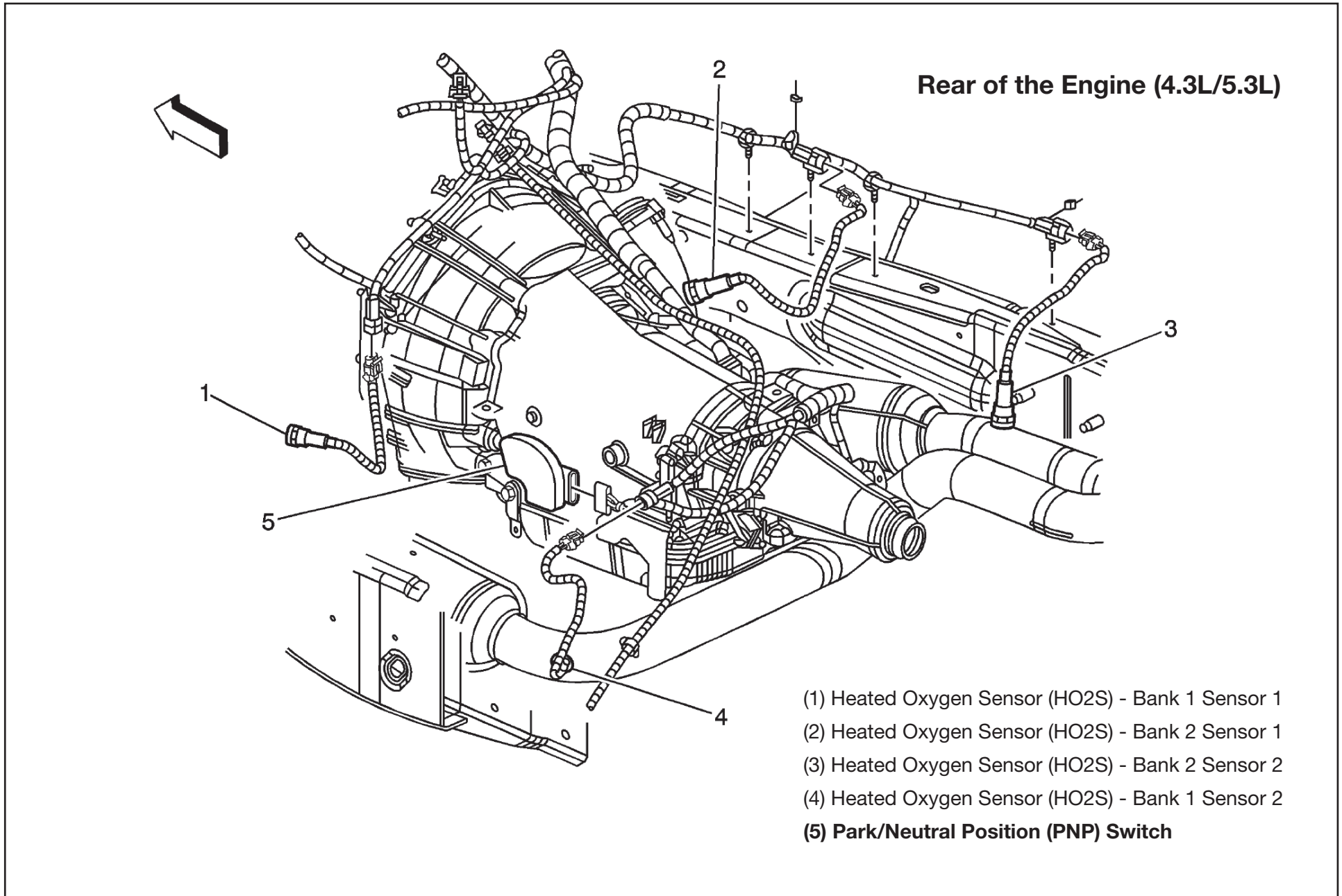

Switches – Park Neutral Position (PNP) Switch – Connector End View

Connector Part Information

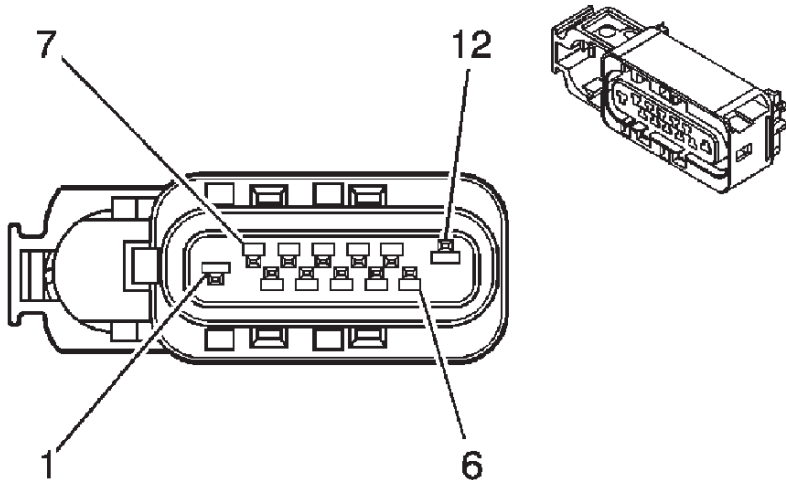

OEM: 15411266

Service: See Catalog

Description: 12-Way F
GT 150 280 Series Sealed (BU)

Terminal Part Information

Pins: 3-8

Terminal/Tray: 12191819/8

Core/Insulation Crimp: Pins 3-8 - E/A

Core/Insulation Crimp: Pins 7 - 2/A

Release Tool/Test Probe: 15315247/J-35616-2A (GY)

Pin	Wire Color	Circuit No.	Function
6	0.35 GY	773	Transmission Range Switch Signal C
7	0.5 BK/WH	1551	Ground (4.3L/5.3L)
	0.8 BK/WH	1551	Ground (4.8L/6.0L)
8	0.35 WH	776	Transmission Range Switch Signal P
9	--	--	Not Used

Pin	Wire Color	Circuit No.	Function
1-2	--	--	Not Used
3	0.35 OG/BK	1786	Park/Neutral Signal
4	0.35 YE	772	Transmission Range Switch Signal B
5	0.35 TN/WH	771	Transmission Range Switch Signal A

Switches – Stop Lamp Switch – Connector End View

Connector Part Information

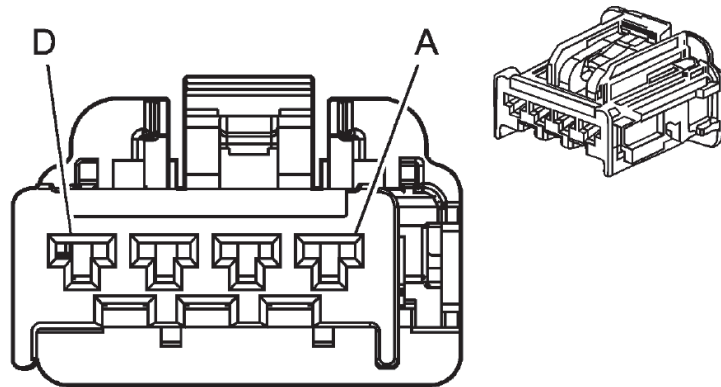

OEM: 15466671

Service: 19149301

Description: 4-Way F
GT 280 Series (L-GY)

Terminal Part Information

Terminal/Tray: 15304711/8

Core/Insulation Crimp: E/A

Core/Insulation Crimp: Pins 7 - 2/A

Release Tool/Test Probe: 15315247/J-35616-4A (PU)

Pin	Wire Color	Circuit No.	Function
A	0.35 L-BU/WH	6311	Torque Converter Clutch (TCC) Brake Signal
B	0.35 PK	239	Ignition Voltage
C	0.35 OG/WH	812	IP Dimming Voltage Reference
D	0.35 PU	7062	Brake Switch Signal

Switches – Engine Coolant Level Switch (Diesel) – Location View

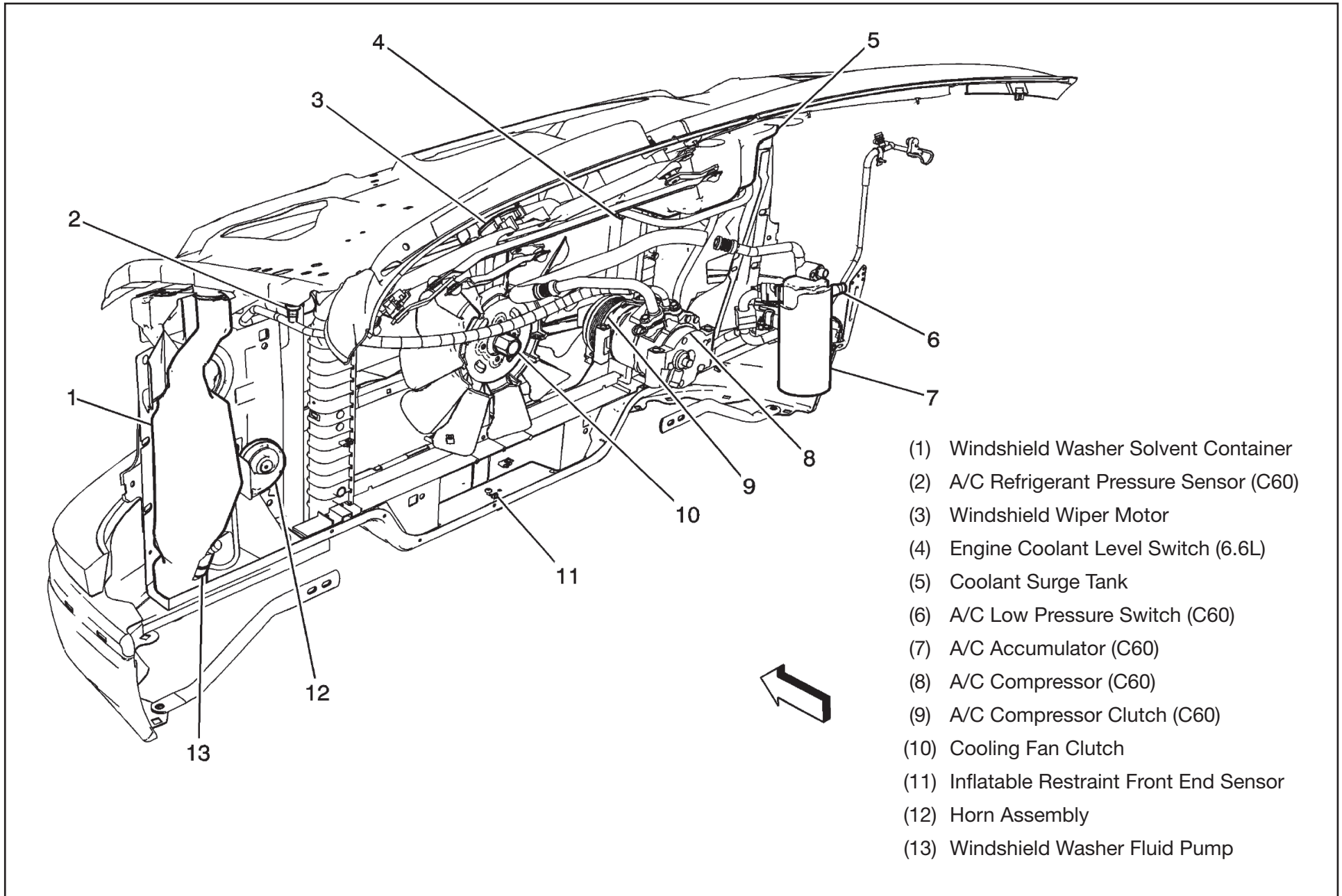

Switches – Engine Coolant Level Switch (Diesel) (6.6L) – Connector End View

Connector Part Information

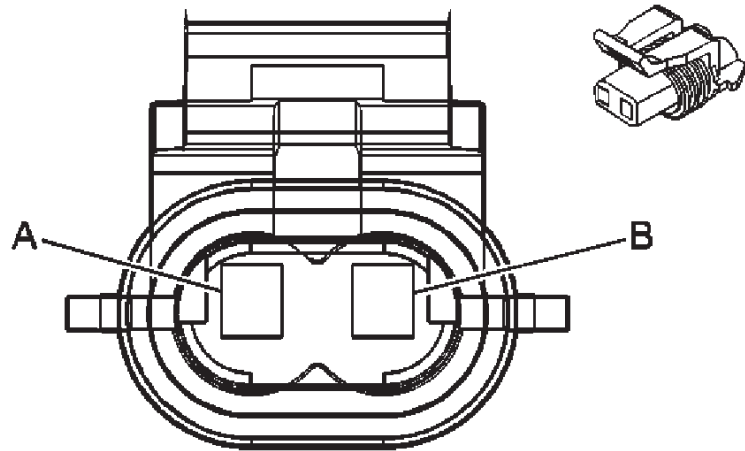

OEM: 15324243

Service: 15324243

Description: 2-Way F Metri-Pack
150 Series Sealed (GY)

Terminal Part Information

Terminal/Tray: 12048074/2

Core/Insulation Crimp: E/1

Release Tool/Test Probe: 12094429/J-35616-14 (GN)

Pin	Wire Color	Circuit No.	Function
A	0.5 L-GN	1478	Coolant Level Switch Signal
B	0.5 BK/WH	351	Ground

Miscellaneous Electrical Components – Back-Up Alarm – Location View

**RR BACK-UP LAMP ALARM AND
ATTACHING COMPONENTS –
INSTALL ALARM TO FRAME RAIL**

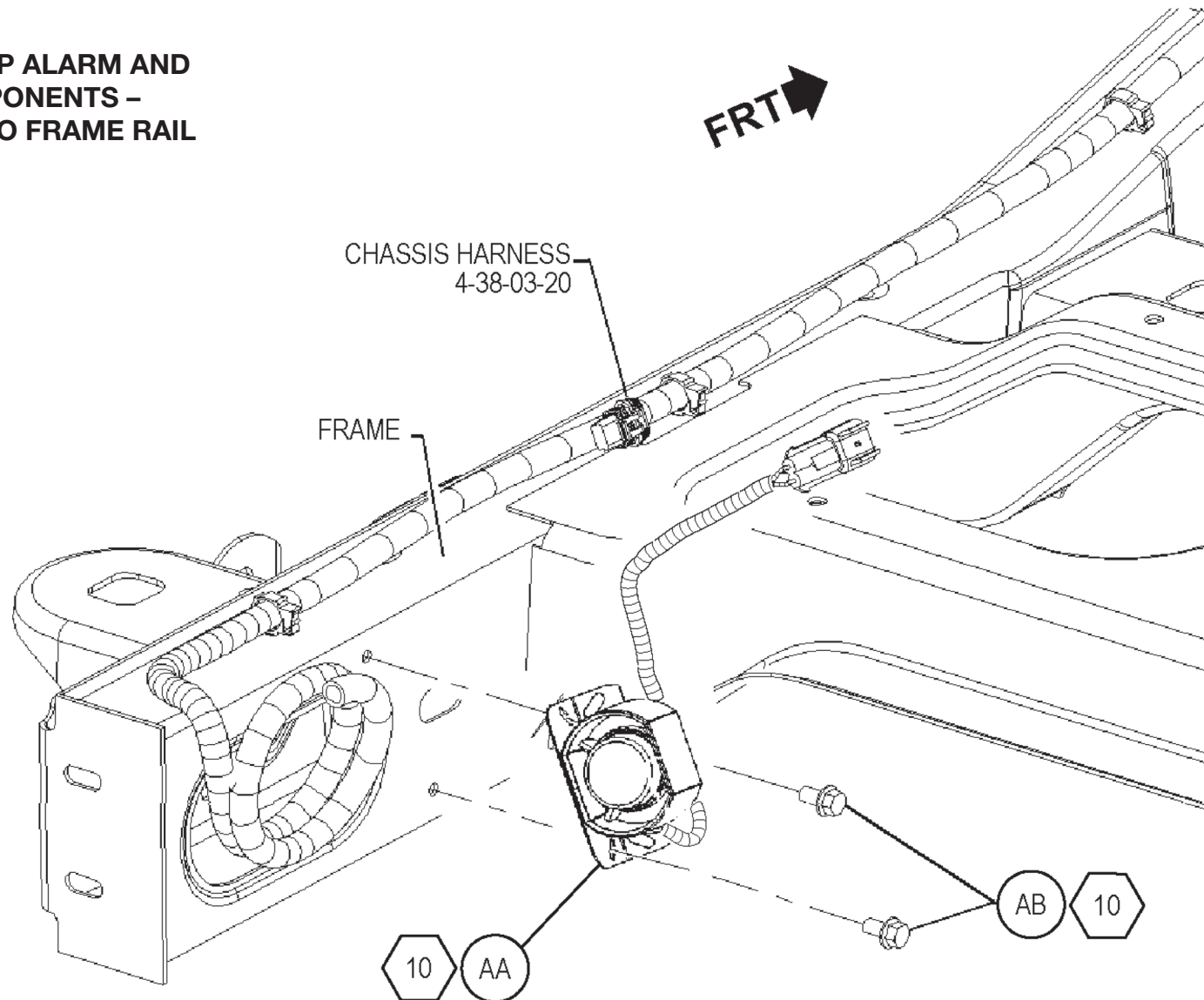

Miscellaneous Electrical Components – Back-Up Alarm – Connector End View

Connector Part Information

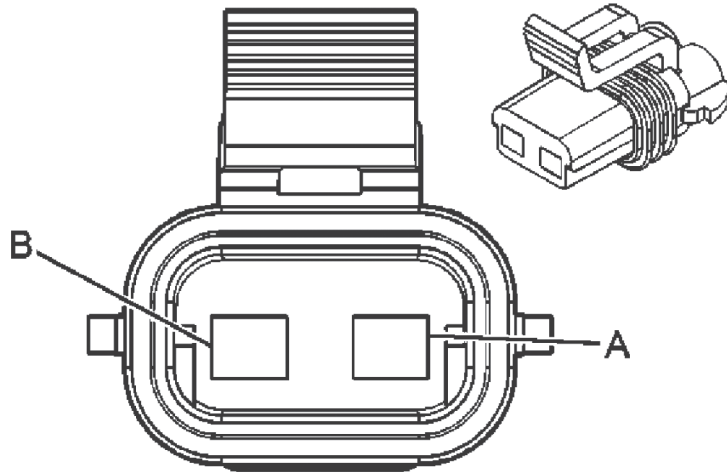

OEM: 15300027

Service: 15300027

Description: 2-Way F Metri-Pack
280 Series Sealed (BK)

Terminal Part Information

Terminal/Tray: 12077411/2

Core/Insulation Crimp: 2/5

Release Tool/Test Probe: 12094430/J-35616-4A (PU)

Pin	Wire Color	Circuit No.	Function
A	1-L-GN	1624	Trailer Backup Lamps Control
B	1 BK	150	Ground

Miscellaneous Electrical Components - Dome Lamp (Passenger/Cargo) - Location View

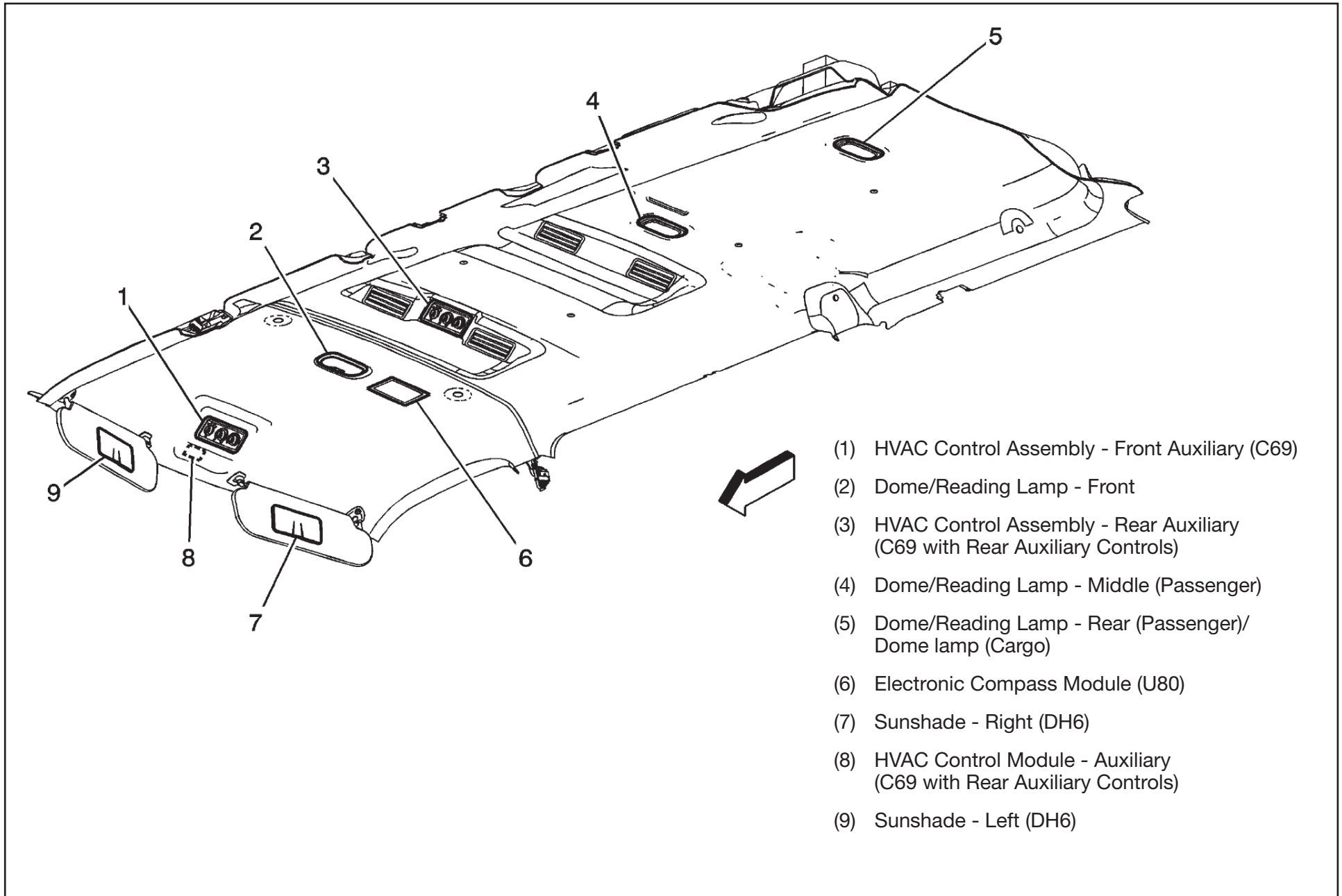

Miscellaneous Electrical Components – Dome Lamp (Cargo) – Connector End View

Connector Part Information

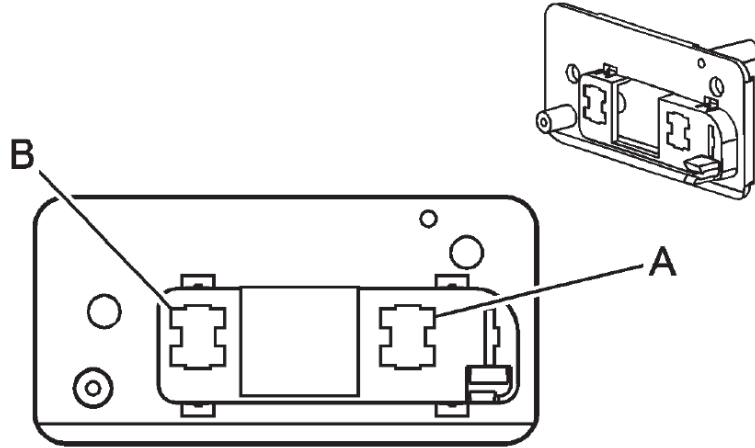

OEM: 15528758

Service: See Catalog

Description: 2-Way F (NA)

Terminal Part Information

Terminal/Tray: See Terminal Repair Kit

Core/Insulation Crimp: See Terminal Repair Kit

Release Tool/Test Probe: See Terminal Repair Kit

Pin	Wire Color	Circuit No.	Function
A	0.8 D-BU/WH	149	Courtesy Lamp Control
B	0.5 BK	850	Ground

Miscellaneous Electrical Components – Automatic Transmission **Shift Lock Control Solenoid – Location View**

**The Automatic Transmission Shift
Lock Control Solenoid is located on the
right side of the steering column.
No illustration available.**

Miscellaneous Electrical Components – Automatic Transmission Shift Lock Control Solenoid – Connector End View

Connector Part Information

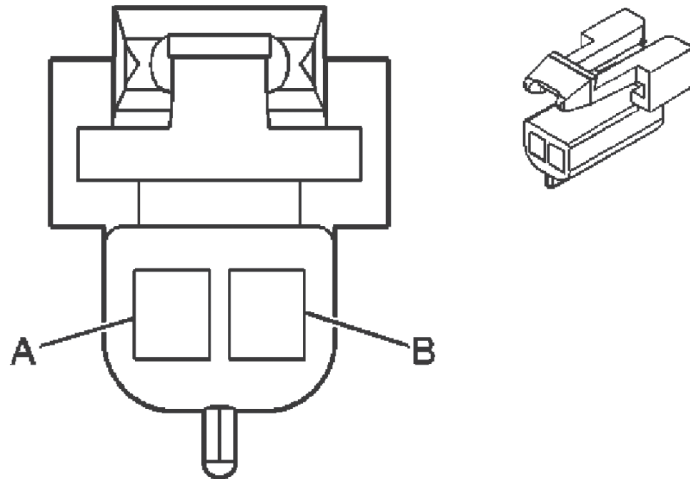

OEM: 12052832

Service: 12101825

Description: 2-Way F Metri-Pack 150 Series (BK)

Terminal Part Information

Terminal/Tray: 12064971/5

Core/Insulation Crimp: E/C

Release Tool/Test Probe: 12094429/J-35616-14 (GN)

Pin	Wire Color	Circuit No.	Function
A	0.5 TN/WH	816	A/T Shift Lock Solenoid Control
B	0.5 BK	350	Ground

Miscellaneous Electrical Components – Automatic Transmission Output Shaft Speed (OSS) Sensor – Location View

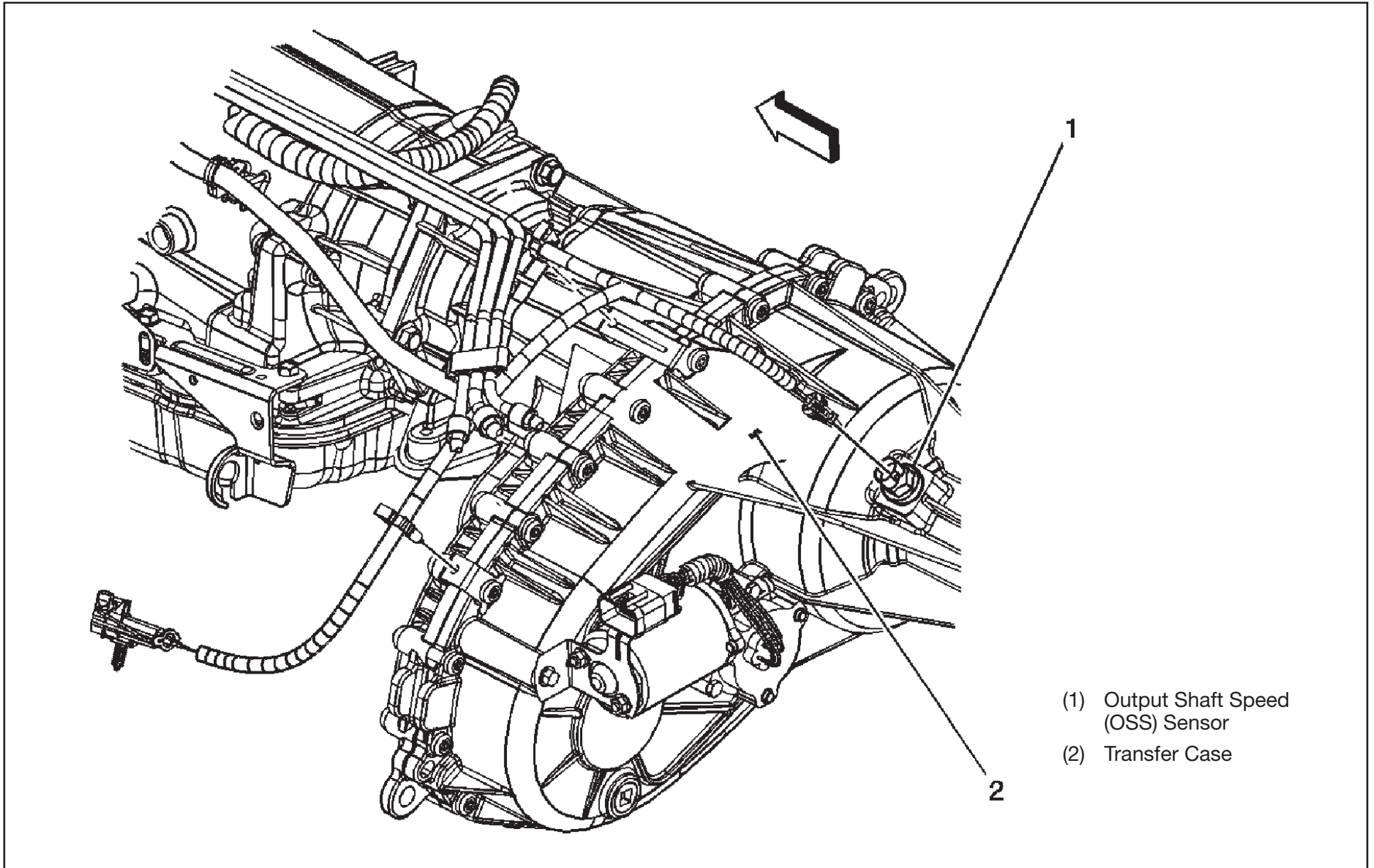

Miscellaneous Electrical Components – Automatic Transmission Output Shaft Speed (OSS) Sensor – Connector End View

Connector Part Information

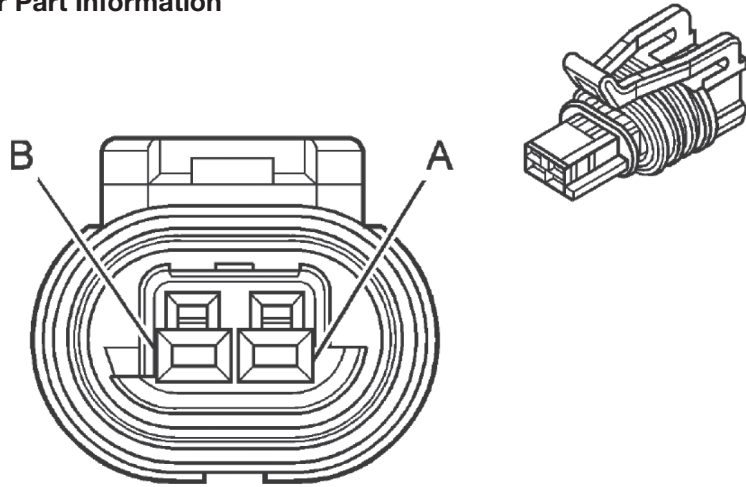

OEM: 15449028

Service: 188987993

Description: 2-Way F GT 150 Series Sealed (BK)

Terminal Part Information

Terminal/Tray: 15326267/19

Core/Insulation Crimp: E/4

Release Tool/Test Probe: 15315247/J-35616-2A (GY)

Pin	Wire Color	Circuit No.	Function
A	0.5 L-GN/BK	822	Vehicle Speed Sensor (VSS) Low Signal
B	0.5 PU/WH	821	Vehicle Speed Sensor (VSS) High Signal

ELECTRICAL MANUAL - 2010 G/H Full Size Van

Miscellaneous Electrical Components - Component and Connector Locations and Pinouts

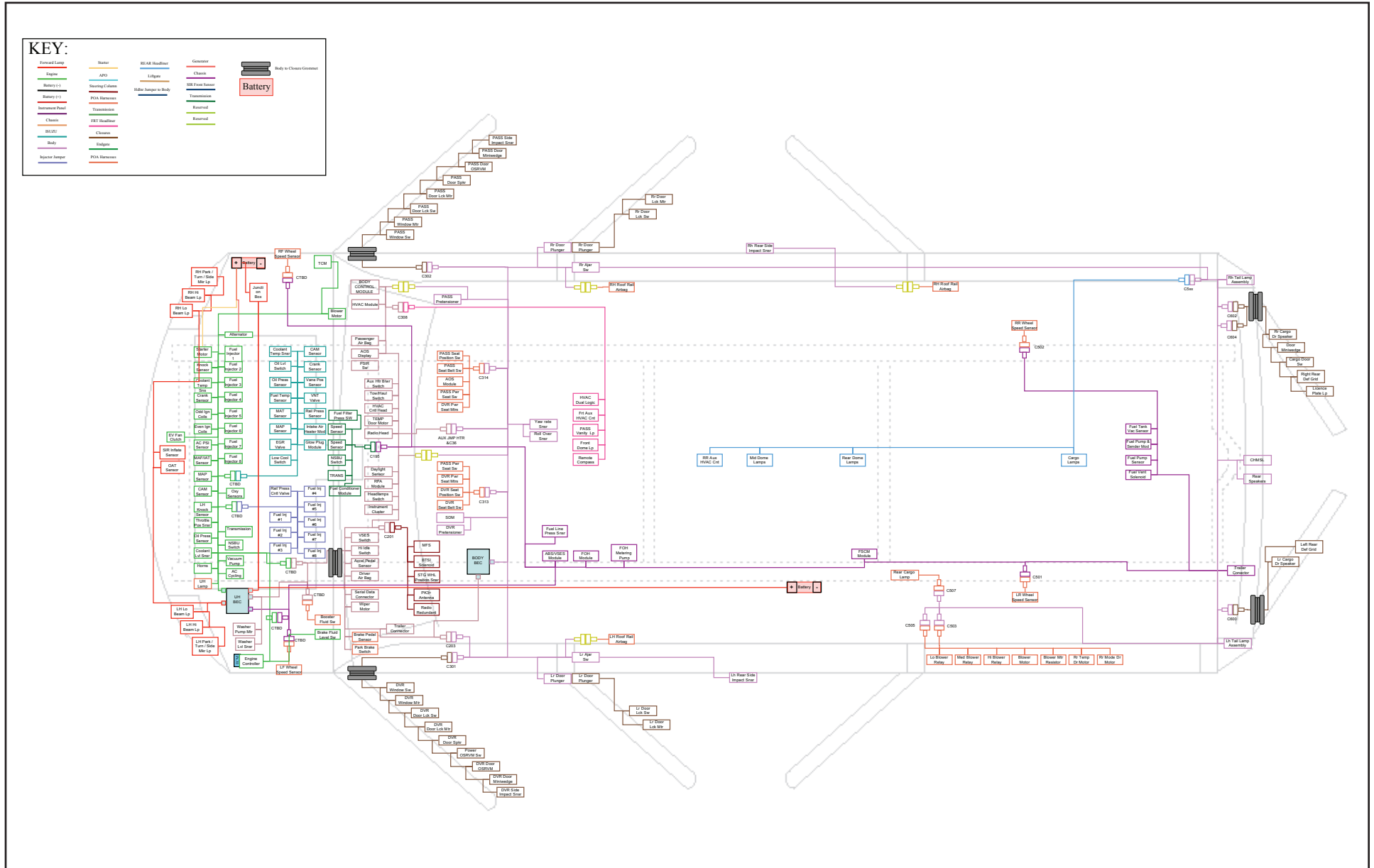

Section C – Connectors – Locations and Pinouts – Data Link – Connector – Location View

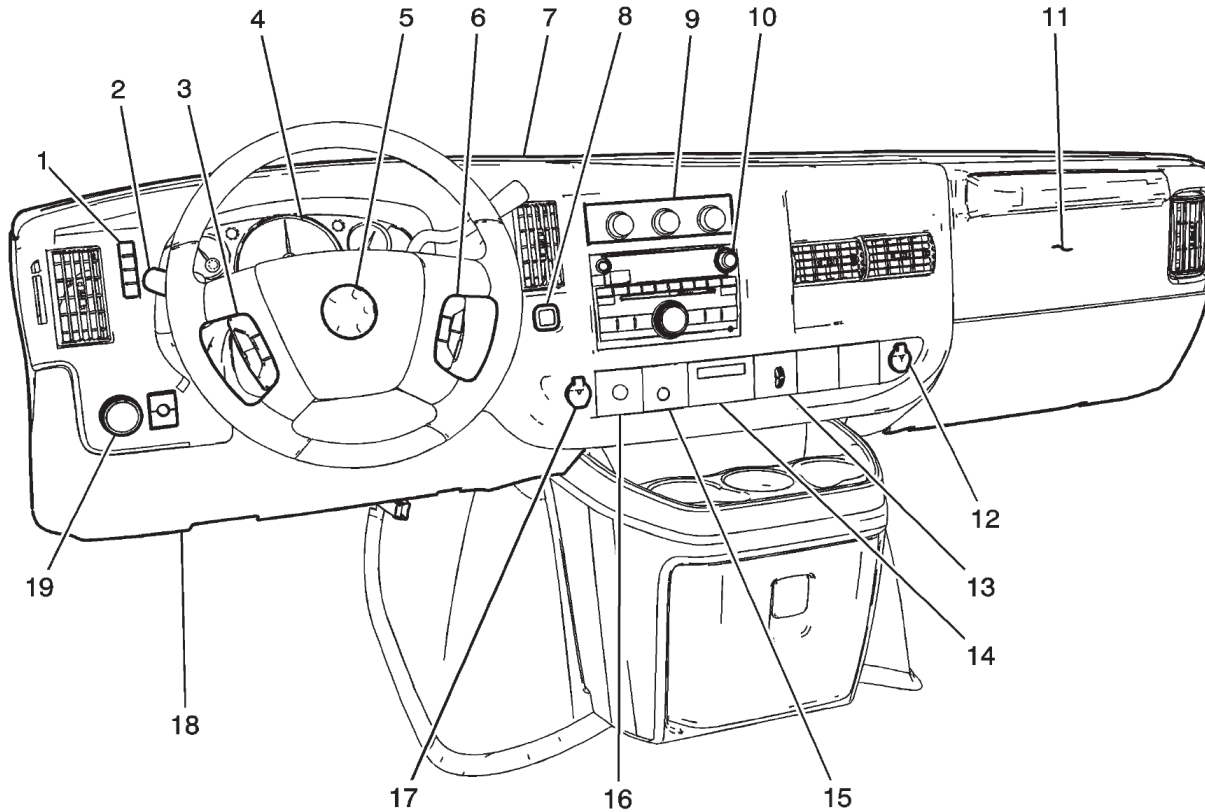

- | | | |
|---|--|--|
| (1) Driver Information Center (DIC) | (9) HVAC Control Assembly | (15) Inflatable Restraint I/P Module Indicator (Light Duty without YF7) |
| (2) Turn Signal/Multifunction Switch | (10) Radio | (16) Traction Control Switch (TCS) (JL4) |
| (3) Steering Wheel Control Switch - Left (K34) | (11) Inflatable Restraint I/P Module | (17) Cigar Lighter (DT4)/Accessory Power Outlet - Center Console 1 (without DT4) |
| (4) Instrument Panel Cluster (IPC) | (12) Accessory Power Outlet - Center Console 2 | (18) Data Link Connector (DLC) |
| (5) Inflatable Restraint Steering Wheel Module | (13) Blower Motor Switch - Auxiliary (C36 without C69) | (19) Headlamp and Panel Dimmer Switch |
| (6) Steering Wheel Control Switch - Right (W1Y) | (14) Tow/Haul Switch | |
| (7) Instrument Panel | | |
| (8) Tow/Haul Switch | | |

Data Link Connector – Connector End View

Connector Part Information

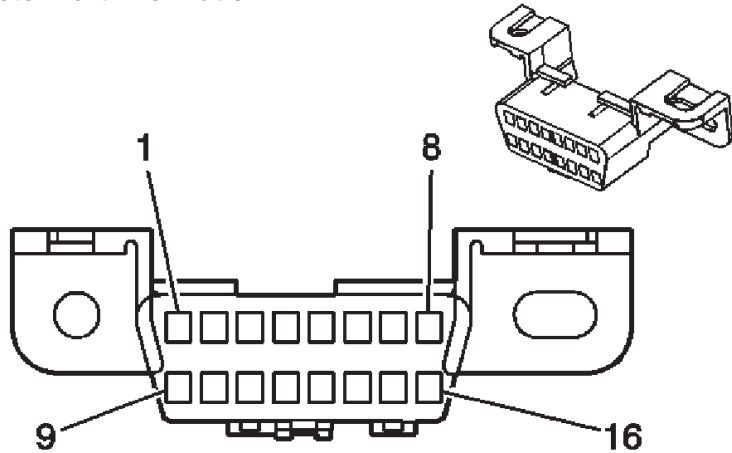

OEM: 12110250

Service: 12110250

Description: 16-Way F
Metri-Pack 150 Series (BK)

Terminal Part Information

Pins: 1, 4-6, 14, 16

Terminal/Tray: 12129484/19

Core/Insulation Crimp: Pins 16 - E/A

Release Tool/Test Probe: 12094429/J-35616-14 (GN)

Pin	Wire Color	Circuit No.	Function
14	0.5 TN	2501	High Speed GMLAN Serial Data Bus (-)
15	--	--	Not Used
16	0.8 RD/WH	640	Battery Positive Voltage

Pin	Wire Color	Circuit No.	Function
1	0.35 D-GN	5060	Low Speed GMLAN Serial Data
2-3	--	--	Not Used
4	0.5 BK/WH	351	Ground
5	0.5 BK/WH	351	Ground
6	0.5 TN/BK	2500	High Speed GMLAN Serial Data Bus (+)
7-13	--	--	Not Used

In-Line Harness Connectors – Location View – Instrument Panel Harness – Passenger Compartment

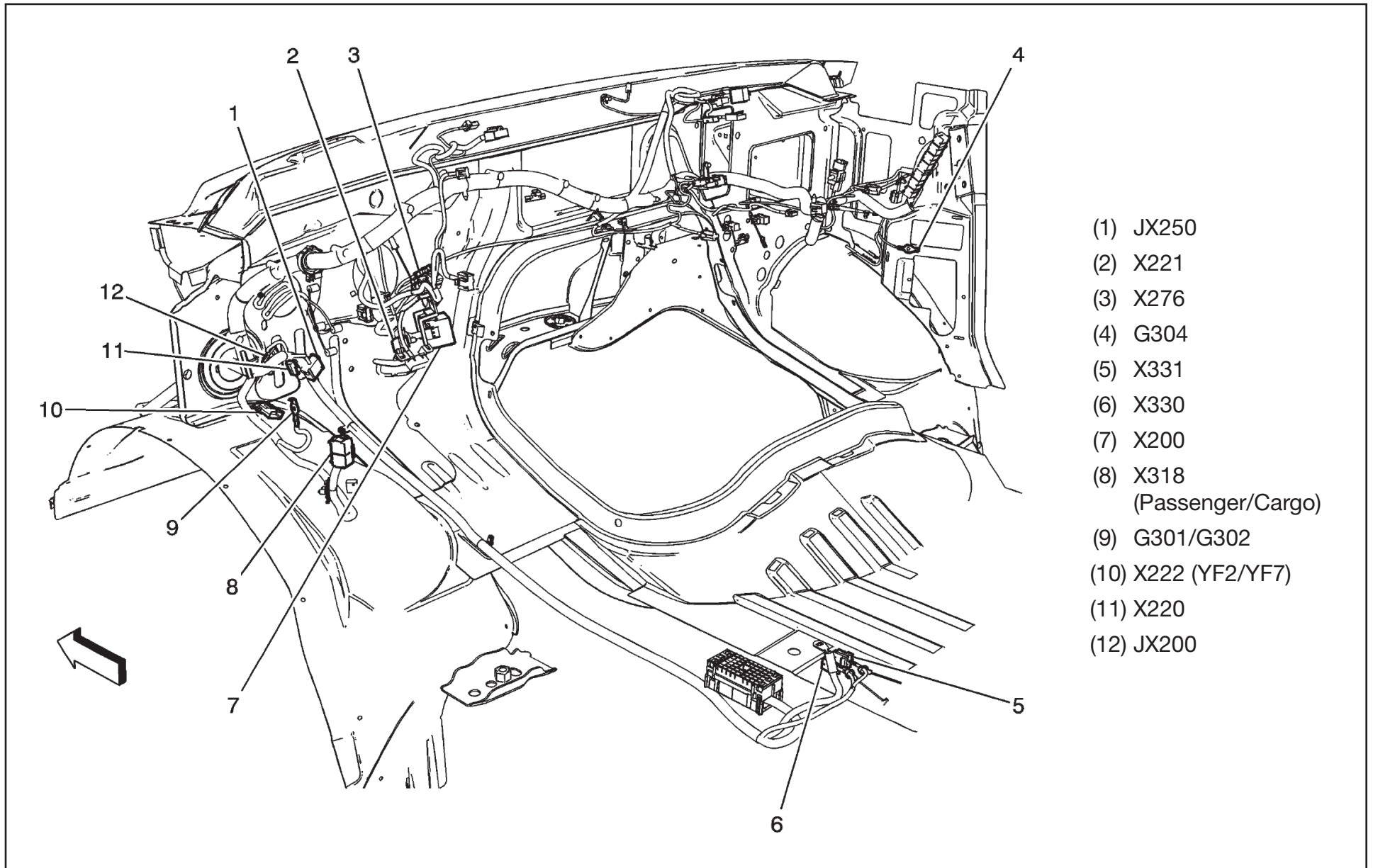

In-Line Harness Connectors – Location View – Steering Column

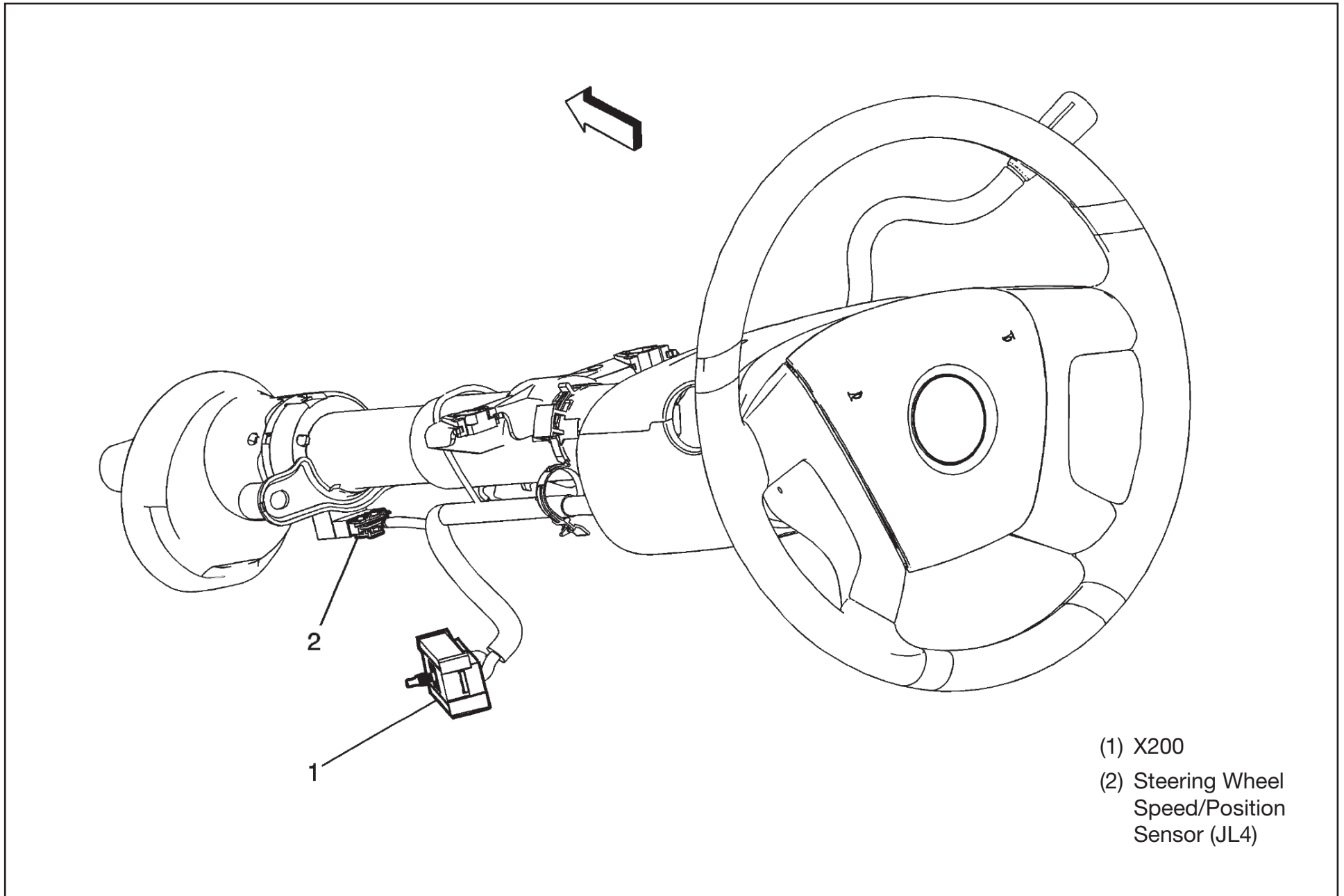

In-Line Harness Connectors – Location View – Body Harness – Left Front Passenger Compartment

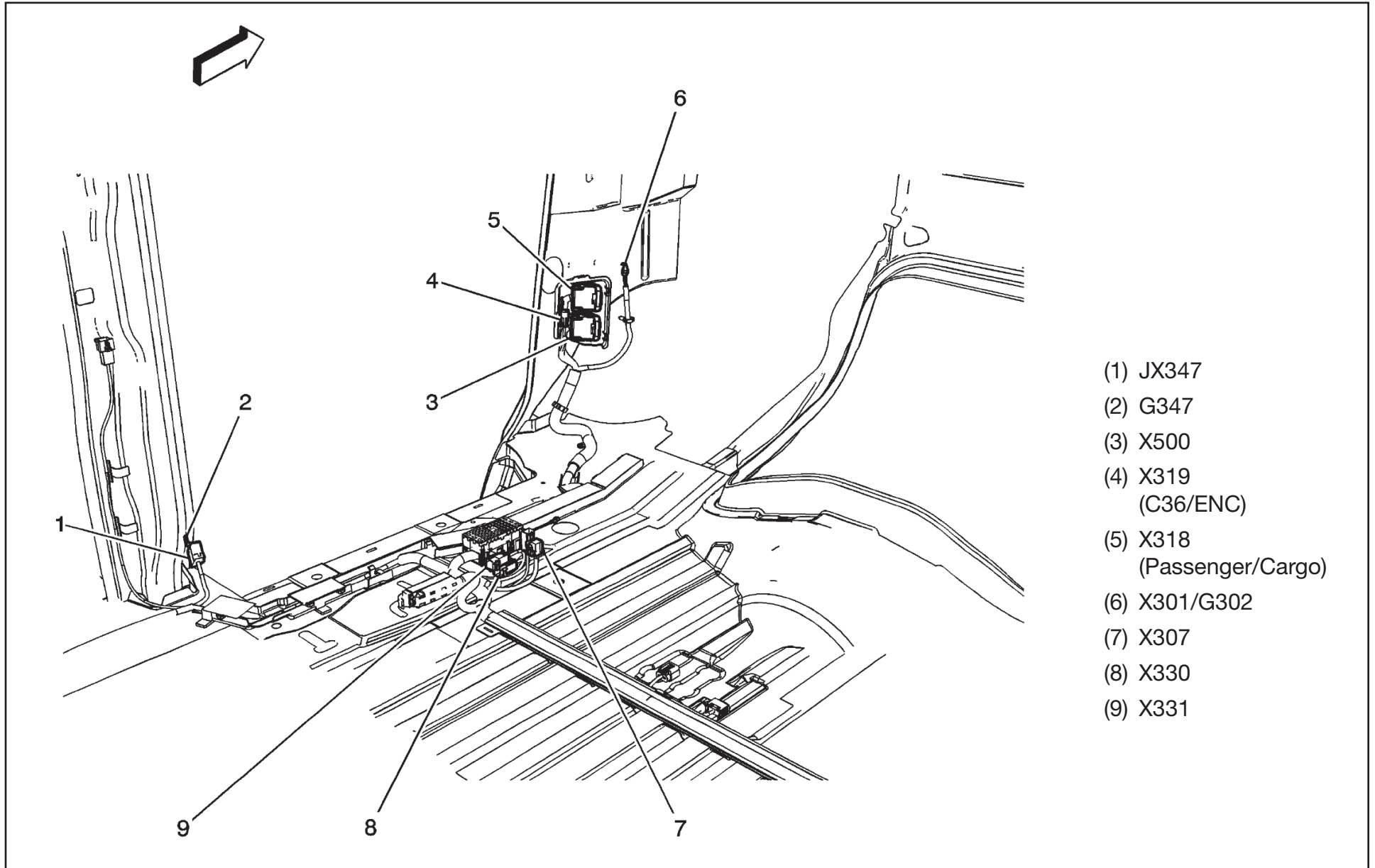

In-Line Harness Connectors – Location View – Body Harness – Left Rear (Passenger/Cargo)

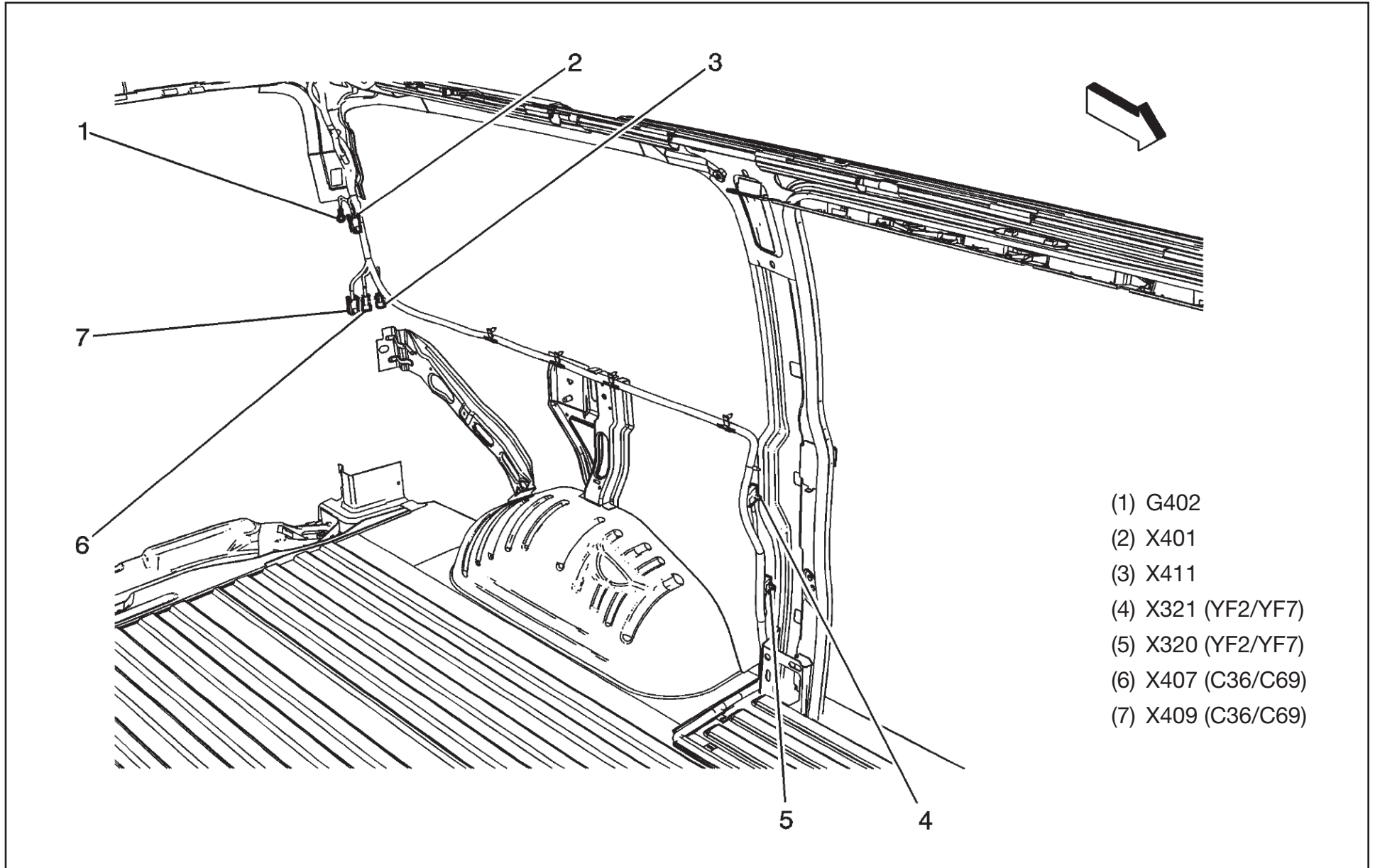

In-Line Harness Connectors – Location View – Body Harness – Right Rear (Passenger/Cargo)

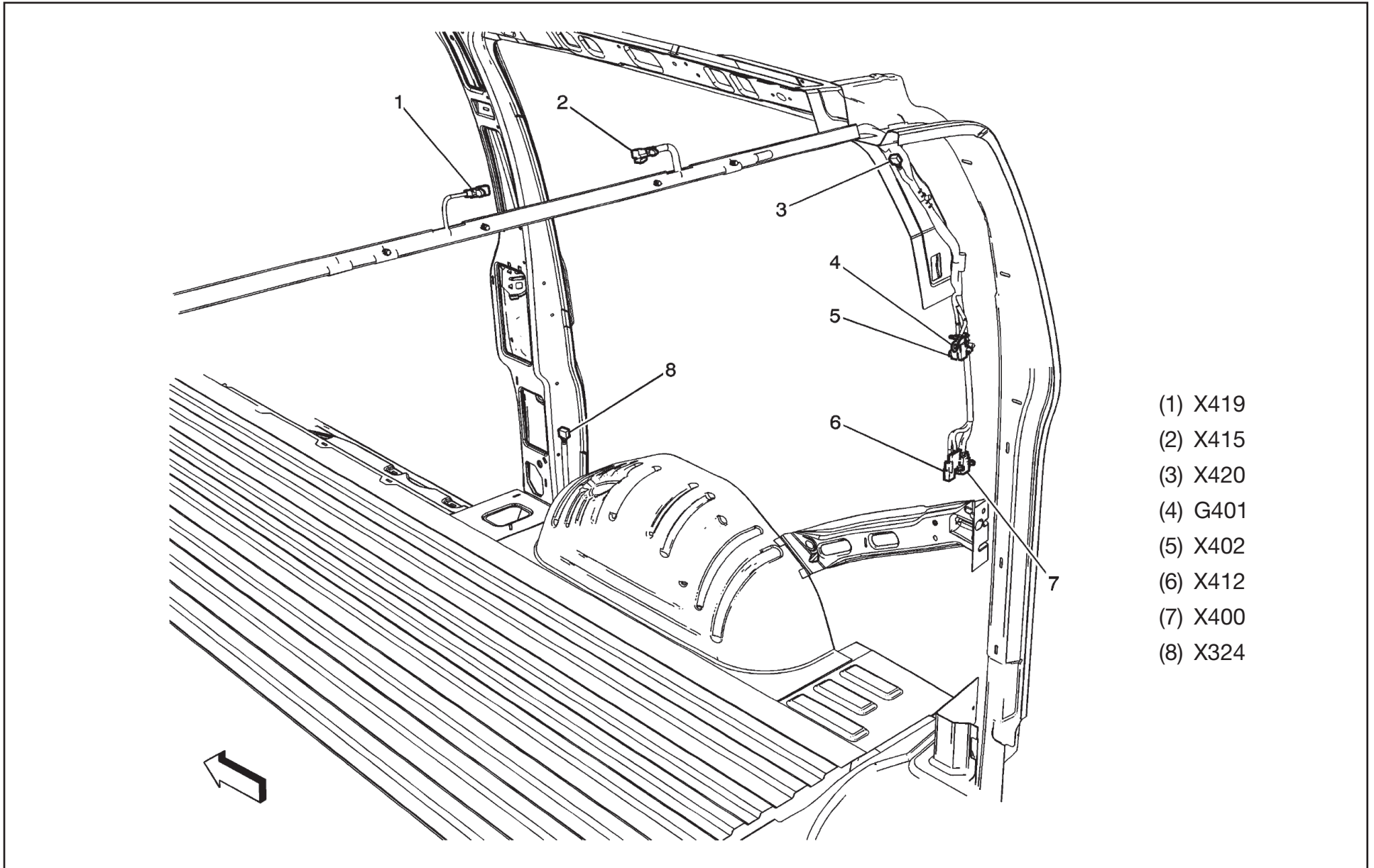

In-Line Harness Connectors – Location View – Front/Rear Headliner Harness

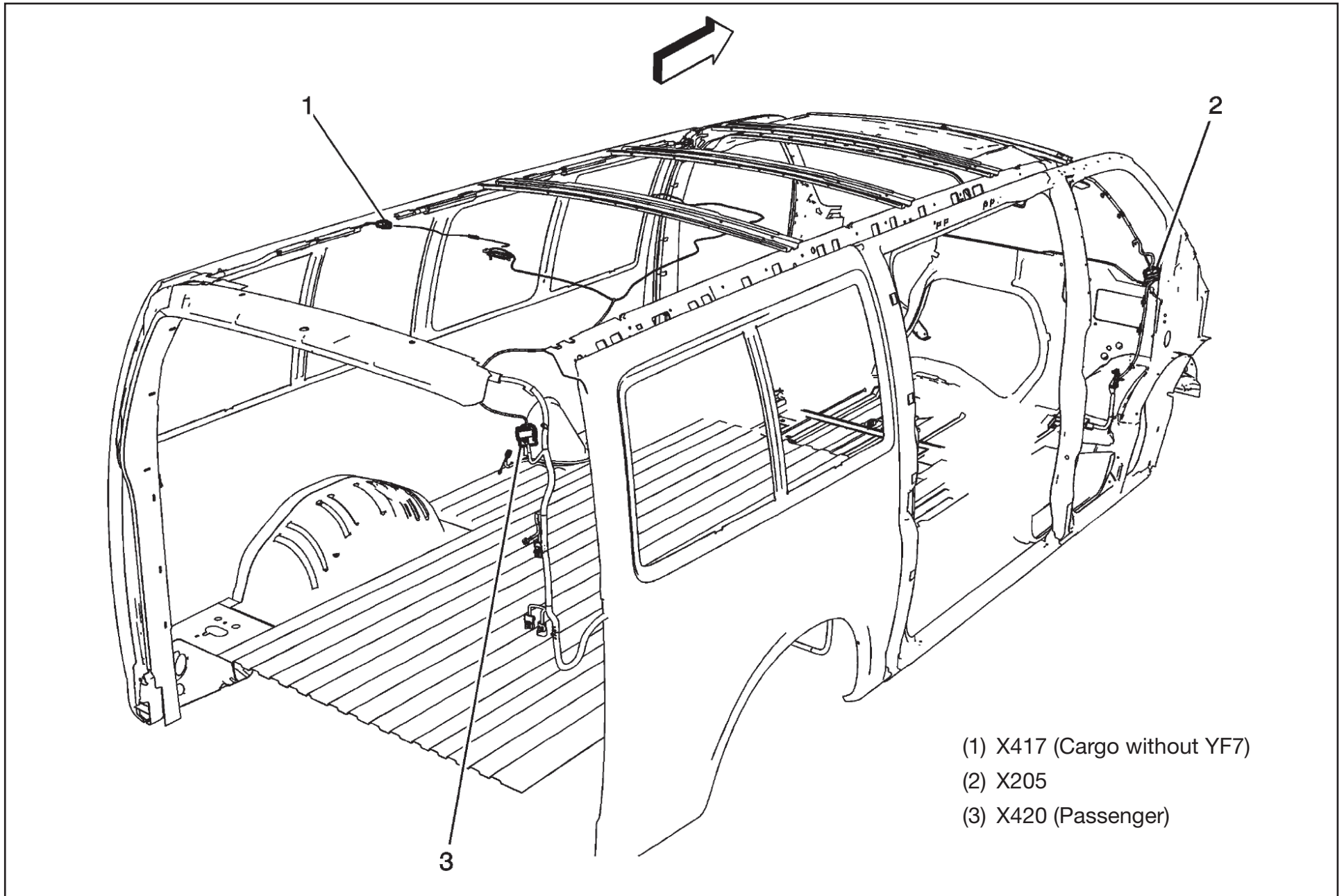

In-Line Harness Connectors – Location View – Chassis Harness (4.3L/4.8L/5.3L/6.0L)

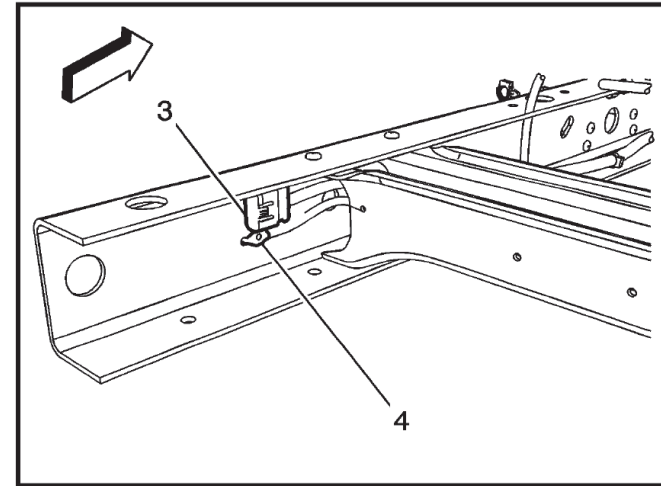
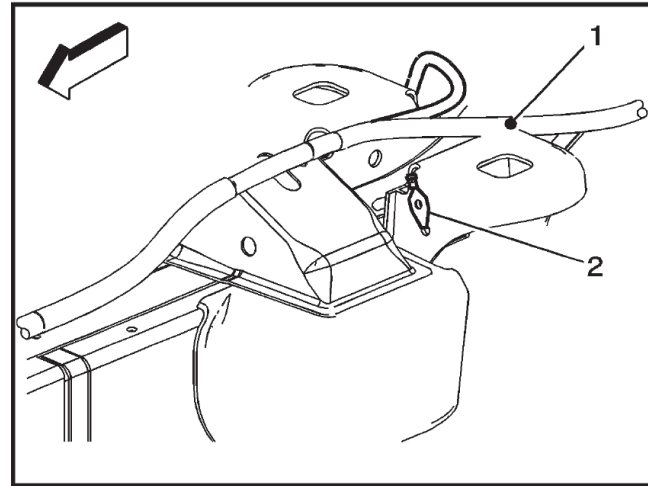

- (1) J402
- (2) G400
(Passenger/Cargo)
- (3) X405
(Cutaway)
- (4) G400
(Cutaway)
- (5) J301
- (6) J315 (5.3L)
- (7) G300
- (8) J315
(4.3L/4.8L/6.0L)
- (9) X101

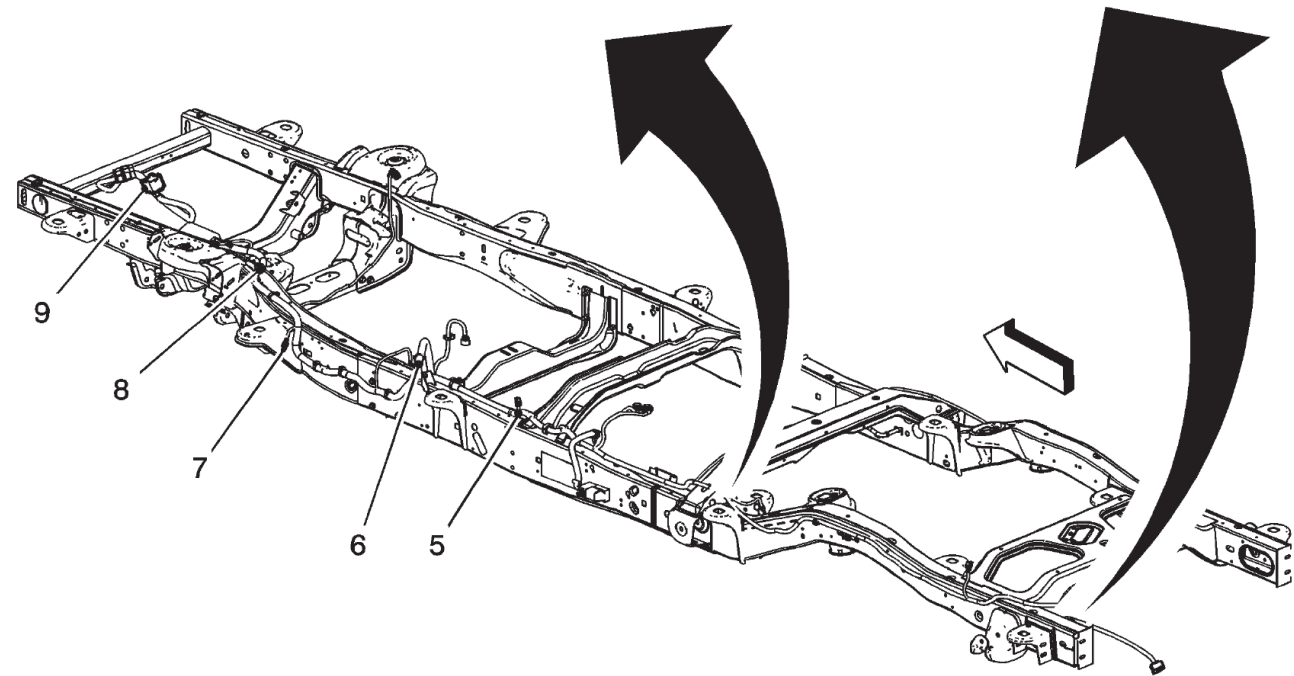

In-Line Harness Connector End Views – X200 – Steering Column Harness to I/P Harness

Connector Part Information

OEM: 12047842

Service: 12047842

Description: 17-Way F

Metri-Pack 150 Series Unsealed (BK)

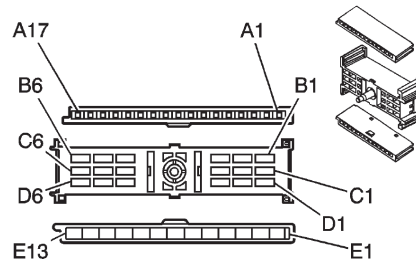

OEM: 12084183

Service: 12084183

Description: 18-Way F

Metri-Pack 280 630 Series Unsealed (BK)

OEM: 12047840

Service: 12047840

Description: 13-Way F

Metri-Pack 280 Series Unsealed (GY)

Terminal Part Information

Pins: B3, C3, D3-D4, E1, E3-E4, E8-E13

Terminal/Tray: 12034046/2

Core/Insulation Crimp: E/A

Release Tool/Test Probe: 12094430/J-35616-4A (PU)

Pins: A1-A3, A5-A6, A7-A9, A11-A17, B2, B5, C2, C4-C5, D2, E2, E5-E7

Terminal/Tray: 12064971/5

Core/Insulation Crimp: E/C

Release Tool/Test Probe: 12094429/J-35616-14 (GN)

Pins: B1, B6, C1, C6, D1, D5-D6

Terminal/Tray: 12015869/3

Core/Insulation Crimp: E/A

Release Tool/Test Probe: 12094430/J-35616-42 (RD)

Pin	Wire Color	Circuit No.	Function
A1	0.35 TN	28	Horn Relay Control
A2	--	--	Not Used
A3	0.35 PK	1444	12-Volt Reference (K34)
A4-A5	--	--	Not Used
A6	0.35 PK	2239	Ignition Voltage
A7-A8	--	--	Not Used
A9	0.35 PK	3	Ignition Voltage
A10	--	--	Not Used
A11	0.35 L-GN	6818	Steering Wheel Control Signal (W1Y)
A12	0.35 YE	6046	Steering Angle Sensor Phase A (JL4)
A13	0.35 D-GN/ WH	7158	Cruise Control Indicator Dimming Signal (K34)
A14	0.35 D-BU	6047	Steering Angle Sensor Phase B (JL4)
A15	0.35 BN	6136	Supply Voltage (K34/W1Y)
A16	0.35 TN	6048	Steering Angle Sensor Phase C (JL4)
A17	0.35 GY	1884	Cruise Control Switch Signal (K34)
B1	0.35 D/WH	540	Battery Positive Voltage
B2	--	--	Not Used
B3	0.35 WH	111	Theft Deterrent Alarm Enable Signal
B4-B5	--	--	Not Used
B6	0.35 PK	1020	Ignition Voltage
C1	0.35 WH	530	Ignition Voltage
C2	--	--	Not Used

(continued on next page)

In-Line Harness Connector End Views – X200 – Steering Column Harness to I/P Harness (cont'd)

Pin	Wire Color	Circuit No.	Function
C3	0.35 YE	307	Headlamp Switch Flash to Pass Signal
C4-C5	--	--	Not Used
C6	0.35 BN	4	Ignition Voltage
D1	0.35 TN/BK	6009	Low Reference
D2	--	--	Not Used
D3	0.35 YE	525	Headlamp Dimmer Switch Low Beam Signal
D4	0.5 TN/WH	816	A/T Shift Lock Solenoid Control
D5	0.35 L-GN	6043	Steering Angle Sensor Signal (JL4)
D6	0.35 PK	94	Windshield Washer Switch Signal

Pin	Wire Color	Circuit No.	Function
E1	0.5 BK	350	Ground
E2	--	--	Not Used
E3	0.5 BK/WH	351	Ground
E4	0.35 OG.BK	6045	Low Reference (JL4)
E5-E7	--	--	Not Used
E8	0.35 D-GN	663	Hazard Switch Left Turn Signal
E9	0.35 TN	664	Hazard Switch Right Turn Signal
E10	0.35 GY	6044	5-Volt Reference (JL4)
E11	0.35 L-BU	1714	Windshield Wiper Switch Low Signal
E12	0.35 L-GN	1715	Windshield Wiper Switch High Signal
E13	0.35 D-GN	5060	Low Speed GMLAN Serial Data

In-Line Harness Connector End Views – X200 – Steering Column Harness to I/P Harness (cont'd)

Connector Part Information

OEM: 15492579
Service: 88988982
Description: 48-Way M Metri-Pack 280 Series (BK)

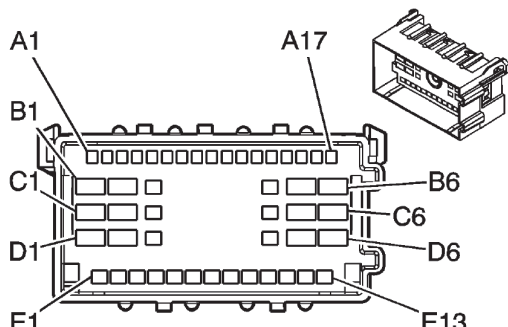

Terminal Part Information
Terminal/Tray: See Terminal Repair Kit
Release Tool/Test Probe: See Terminal Repair Kit

Pin	Wire Color	Circuit No.	Function
A1	0.35 TN	28	Horn Relay Control
A2	--	--	Not Used
A3	0.35 PK	1444	12-Volt Reference (K34)
A4-A5	--	--	Not Used
A6	0.35 PK	2239	Ignition Voltage
A7-A8	--	--	Not Used
A9	0.35 PK	3	Ignition Voltage
A10	--	--	Not Used
A11	0.35 L-GN	6818	Steering Wheel Control Signal (W1Y)
A12	0.5 YE	6046	Steering Angle Sensor Phase A (JL4)
A13	0.35 D-GN/ WH	7158	Cruise Control Indicator Dimming Signal (K34)
A14	0.5 D-BU	6047	Steering Angle Sensor Phase B (JL4)

Pin	Wire Color	Circuit No.	Function
A15	0.35 BN	6136	Supply Voltage (K34/W1Y)
A16	0.5 TN	6048	Steering Angle Sensor Phase C (JL4)
A17	0.35 GY	1884	Cruise Control Switch Signal (K34)
B1	0.35 D/WH	540	Battery Positive Voltage
B2	--	--	Not Used
B3	0.35 WH	111	Theft Deterrent Alarm Enable Signal
B4-B5	--	--	Not Used
B6	0.35 PK	1020	Ignition Voltage
C1	0.35 WH	530	Ignition Voltage
C2	--	--	Not Used
C3	0.35 YE	307	Headlamp Switch Flash to Pass Signal
C4-C5	--	--	Not Used
C6	0.35 BN	4	Ignition Voltage
D1	0.35 TN/BK	6009	Low Reference
D2	--	--	Not Used
D3	0.35 YE	525	Headlamp Dimmer Switch Low Beam Signal
D4	0.5 TN/WH	816	A/T Shift Lock Solenoid Control
D5	0.35 L-GN	6043	Steering Angle Sensor Signal (JL4)
D6	0.35 PK	94	Windshield Washer Switch Signal

In-Line Harness Connector End Views – X200 – Steering Column Harness to I/P Harness (cont'd)

Pin	Wire Color	Circuit No.	Function
E1	0.5 BK	350	Ground
E2	--	--	Not Used
E3	0.5 BK/WH	351	Ground
E4	0.5 OG.BK	6045	Low Reference (JL4)
E5-E7	--	--	Not Used
E8	0.35 D-GN	663	Hazard Switch Left Turn Signal

Pin	Wire Color	Circuit No.	Function
E9	0.35 TN	664	Hazard Switch Right Turn Signal
E10	0.5 GY	6044	5-Volt Reference (JL4)
E11	0.35 L-BU	1714	Windshield Wiper Switch Low Signal
E12	0.35 L-GN	1715	Windshield Wiper Switch High Signal
E13	0.35 D-GN	5060	Low Speed GMLAN Serial Data

In-Line Harness Connector End Views – X205 – Front Headliner Harness to Body Harness

Connector Part Information

OEM: 15326952
Service: 15306426
Description: 16-Way F
GT 280 Series (BK)

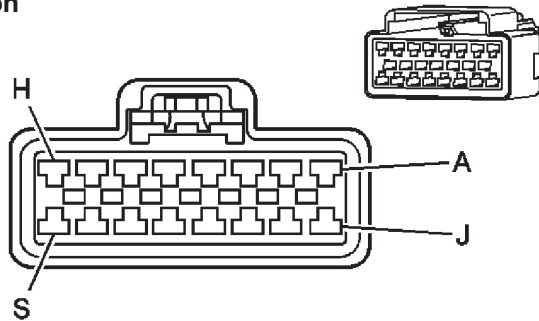

Terminal Part Information

Terminal/Tray: 15304711/8
Core/Insulation Crimp: Pins: G, S : 2/A
Core/Insulation Crimp: Pins: E/A
Release Tool/Test Probe: 15315247/J-35616-4A (PU)

Pin	Wire Color	Circuit No.	Function
A	0.35 BN	441	Ignition Voltage (U80)
B	0.5 PU/WH	5264	Rear Auxiliary Mode Door Control (C69)
C	0.5 PK/BK	5265	Rear Auxiliary Blower Motor Switch Control (C69)
D	0.35 GY	2599	Auxiliary Mode Door Control (C69)
E	0.5 WH	1924	Auxiliary Blower Motor High Control (C69)
F	0.35 BN	341	Ignition Voltage (C69)

Pin	Wire Color	Circuit No.	Function
G	1 BK	1850	Ground (C69/DH6)
	0.8 BK	1850	Ground (without C69/DH6/YF1)
H	0.5 D-BU/WH	149	Courtesy Lamp Control (without YF7)
J	0.35 BK/WH	351	Ground (U80)
K	0.5 BN	5263	Rear Auxiliary Air Temperature Door Control (C69)
L	0.35 D-GN	6134	Local Interconnect Network 3 (U80)
M	0.35 OG	2775	Auxiliary Air Temperature Door Control (C69)
N	0.5 OG	1925	Auxiliary Blower Motor Medium Control (C69)
P	0.5 D-BU	1926	Auxiliary Blower Motor Low Control (C69)
R	0.35 BN/WH	230	Instrument Panel Lamps Dimming Control (C69)
S	0.8 OG	1732	Courtesy Lamps Control (without YF7)

In-Line Harness Connector End Views – X205 – Front Headliner Harness to Body Harness (cont'd)

Connector Part Information

OEM: 13573920

Service: See Catalog

Description: 16-Way M
GT 280 Series (BK)

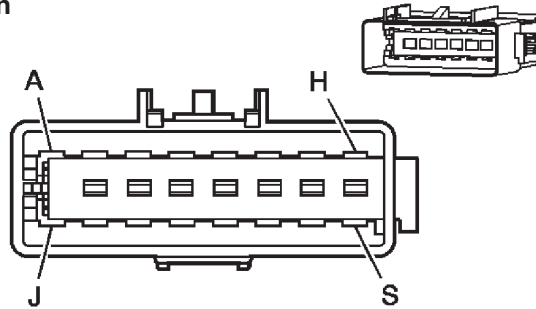

Terminal Part Information

Terminal/Tray: See Terminal Repair Kit

Core/Insulation Crimp: See Terminal Repair Kit

Release Tool/Test Probe: See Terminal Repair Kit

Pin	Wire Color	Circuit No.	Function
A	0.35 BN	441	Ignition Voltage (U80)
B	0.5 PU/WH	5264	Rear Auxiliary Mode Door Control (C69)
C	0.5 PK/BK	5265	Rear Auxiliary Blower Motor Switch Control (C69)
D	0.35 GY	2599	Auxiliary Mode Door Control (C69)
E	0.35 WH	1924	Auxiliary Blower Motor High Control (C69)
F	0.35 BN	341	Ignition Voltage (C69)

Pin	Wire Color	Circuit No.	Function
G	1 BK	1850	Ground
H	0.5 D-BU/WH	149	Courtesy Lamp Control (without YF7)
J	0.35 BK/WH	351	Ground (U80)
K	0.5 BN	5263	Rear Auxiliary Air Temperature Door Control (C69)
L	0.35 D-GN	6134	Local Interconnect Network 3 (U80)
M	0.35 OG	2775	Auxiliary Air Temperature Door Control (C69)
N	0.35 OG	1925	Auxiliary Blower Motor Medium Control (C69)
P	0.35 D-BU	1926	Auxiliary Blower Motor Low Control (C69)
R	0.35 BN/WH	230	Instrument Panel Lamps Dimming Control (C69)
S	0.8 OG	1732	Courtesy Lamps Control

In-Line Harness Connector End Views – X222 – (YF2/YF7) Upfitter Provision Harness to I/P Harness

Connector Part Information

OEM: 12191740
 Service: 12191740
 Description: 4-Way F
 Metri-Pack 280 Series (YE)

Terminal Part Information

Terminal/Tray: 12034046/2
 Core/Insulation Crimp: E/A
 Release Tool/Test Probe: 12094430/J-35616-4A (PU)

Pin	Wire Color	Circuit No.	Function
A1	0.5 TN	3021	Steering Wheel Module - Stage 1 - High Control
A2	0.5 BN	3020	Steering Wheel Module - Stage 1 - Low Control
B1	0.5 WH	3023	Steering Wheel Module - Stage 2 - High Control
B2	0.5 PK	3022	Steering Wheel Module - Stage 2 - Low Control (Light Duty)

Connector Part Information

OEM: 15304974
 Service: 15306013
 Description: 4-Way M
 Metri-Pack 280 Series (YE)

Terminal Part Information

Terminal/Tray: See Terminal Repair Kit
 Core/Insulation Crimp: See Terminal Repair Kit
 Release Tool/Test Probe: See Terminal Repair Kit

Pin	Wire Color	Circuit No.	Function
A1	0.5 TN	3021	Steering Wheel Module - Stage 1 - High Control
A2	0.5 BN	3020	Steering Wheel Module - Stage 1 - Low Control
B1	0.5 WH	3023	Steering Wheel Module - Stage 2 - High Control
B2	0.5 PK	3022	Steering Wheel Module - Stage 2 - Low Control (Light Duty)

In-Line Harness Connector End Views – X318 – (Passenger/Cargo) I/P Harness to Body Harness

Connector Part Information

OEM: 15448130

Service: See Catalog

Description: 40-Way F
GT 150 280 Series (L-GY)

Terminal Part Information

Pins: A1-A2, A7-A8, B1-B4, B6-B11, C2-C4, C6-C12, D1-D2, D7-D8

Terminal/Tray: 12191812/19

Core/Insulation Crimp: Pins: A1-A2, B1, B3-B4, C3-C4, D1-D2 : C/A

Cor/Insulation Crimp: Pins: A7-A8, B2, B6-B11, C2, C6-C12, D7-D8 : E/C

Release Tool/Test Probe: 15315247/J-35616-2A (GY)

Pins: A4-A6, D3-D6

Terminal/Tray: 15304711/8

Core/Insulation Crimp: Pins: D3 : 2/A

Cor/Insulation Crimp: Pins: A4-A6, D4-D6 ; E/A

Release Tool/Test Probe: 15315247/J-35616-4A (PU)

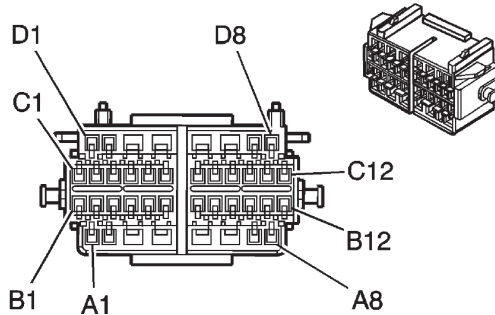

Pin	Wire Color	Circuit No.	Function
A1	0.8 OG	1853	Right Front Midrange Speaker Output (+)
A2	0.8 D-GN	1953	Right Front Midrange Speaker Output (-)
A3	0.5 BK/WH	1751	Ground
A4	0.5 TN.BK	371	Instrument Panel Module Disable Switch Signal (C99)
A5	0.5 WH/BK	6436	CAN Bus Low Terminated Serial Data (JL4)
A6	0.5 BN/WH	6437	CAN Bus High Terminated Serial Data (JL4)

Pin	Wire Color	Circuit No.	Function
A7	0.35 D-BU/WH	1179	Left Rear Door Open Switch Signal (E26)
A8	0.35 YE/BK	1181	Right Rear Door Open Switch Signal
B1	0.8 L/BU	1320	CHMSL Control
B2	0.5 BK/WH	1751	Ground (Light Duty)
B3	0.8 TN	1855	Right Rear Midrange Speaker Output (+)
B4	0.8 OG	1955	Right Rear Midrange Speaker Output (-)
B5	0.5 BK/WH	1751	Ground
B6	0.5 GY/BK	1337	5-Volt Reference (JL4)
B7	0.5 BN.WH	6618	Discriminating Sensor - Signal
B8	0.5 BU/WH	6619	Low Reference
B9	0.35 D-GN	5060	Low Speed GMLAN Serial Data (Light Duty without YF7)
B10	0.35 D-GN	5060	Low Speed GMLAN Serial Data
B11	0.35 D-GN	6134	Local Interconnect Network 3
B12	--	--	Not Used
C1	--	--	Not Used
C2	0.35 PK	1139	Ignition Voltage
C3	0.8 TN	1859	Left Rear Midrange Speaker Output (+)
C4	0.8 WH	1959	Left Rear Midrange Speaker Output (-)
C5	--	--	Not Used
C6	0.5 BK/PU	7499	Low Reference (JL4)
C7	0.35 L-GN	5926	Rear Access Open Switch Signal
C8	0.35 PK/BK	1303	Cargo Door Ajar Switch Signal

In-Line Harness Connector End Views – X318 – (Passenger/Cargo) I/P Harness to Body Harness (cont'd)

Pin	Wire Color	Circuit No.	Function
C9	0.35 TN/WH	746	Right Front Door Ajar Switch Signal
C10	0.35 L-GN	1177	Right Front Door Open Switch Signal
C11	0.5 TN	126	Left Front Door Open Switch Signal
C12	0.35 GY/BK	745	Left Front Door Ajar Switch Signal
D1	0.8 D-BU	1857	Left Front Midrange Speaker Output (+)
D2	0.8 L-BU	1957	Left Front Midrange Speaker Output (-)

Pin	Wire Color	Circuit No.	Function
D3	0.8 OG	1732	Courtesy Lamps Control
	0.5 OG	1732	Courtesy Lamps Control
D4	0.5 PK	353	Instrument Panel Module Suppression Indicator Control (C99)
D5	0.5 PK/BK	780	Driver Door Lock Switch Lock Signal (AU3)
D6	0.5 OG.BK	781	Driver Door Lock Switch Unlock Signal (AU3)
D7	0.35 L-BU	244	Passenger Door Lock Switch Lock Control (AU3)
D8	0.35 D-BU	245	Passenger Door Lock Switch Unlock Control (AU3)

In-Line Harness Connector End Views – X318 – (Passenger/Cargo) I/P Harness to Body Harness (cont'd)

Connector Part Information

OEM: 15475870
Service: 88988616
Description: 40-Way M
GT 150 280 Series (L-GY)

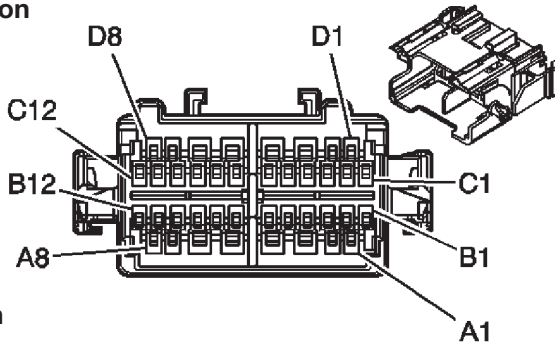

Terminal Part Information

Terminal/Tray: See Terminal Repair Kit
Core/Insulation Crimp: See Terminal Repair Kit
Release Tool/Test Probe: See Terminal Repair Kit

Pin	Wire Color	Circuit No.	Function
A1	0.8 OG	1853	Right Front Midrange Speaker Output (+)
A2	0.8 D-GN	1953	Right Front Midrange Speaker Output (-)
A3	0.5 BK/WH	1751	Ground
A4	0.5 TN.BK	371	Instrument Panel Module Disable Switch Signal (C99)
A5	0.5 WH/BK	6436	CAN Bus Low Terminated Serial Data (JL4)
A6	0.5 BN/WH	6437	CAN Bus High Terminated Serial Data (JL4)
A7	0.35 D-BU/WH	1179	Left Rear Door Open Switch Signal (E26)
A8	0.35 YE/BK	1181	Right Rear Door Open Switch Signal
B1	0.8 L/BU	1320	CHMSL Control
B2	0.5 BK/WH	1751	Ground (Light Duty)

Pin	Wire Color	Circuit No.	Function
B3	1 TN	1855	Right Rear Midrange Speaker Output (+)
B4	1 OG	1955	Right Rear Midrange Speaker Output (-)
B5	0.5 BK/WH	1751	Ground
B6	0.5 GY/BK	1337	5-Volt Reference (JL4)
B7	0.5 BN/WH	6618	Discriminating Sensor - Signal
B8	0.5 BU/WH	6619	Low Reference
B9	0.5 D-GN	5060	Low Speed GMLAN Serial Data (Light Duty without YF7)
B10	0.35 D-GN	5060	Low Speed GMLAN Serial Data
B11	0.35 D-GN	6134	Local Interconnect Network 3
B12	--	--	Not Used
C1	--	--	Not Used
C2	0.35 PK	1139	Ignition Voltage
C3	1 TN	1859	Left Rear Midrange Speaker Output (+)
C4	1 WH	1959	Left Rear Midrange Speaker Output (-)
C5	--	--	Not Used
C6	0.5 BK/PU	7499	Low Reference (JL4)
C7	0.35 L-GN	5926	Rear Access Open Switch Signal
C8	0.35 PK/BK	1303	Cargo Door Ajar Switch Signal
C9	0.35 TN/WH	746	Right Front Door Ajar Switch Signal
C10	0.35 L-GN	1177	Right Front Door Open Switch Signal
C11	0.35 TN	126	Left Front Door Open Switch Signal

In-Line Harness Connector End Views – X318 – (Passenger/Cargo) I/P Harness to Body Harness (cont'd)

Pin	Wire Color	Circuit No.	Function
C12	0.35 GY/BK	745	Left Front Door Ajar Switch Signal
D1	0.8 D-BU	1857	Left Front Midrange Speaker Output (+)
D2	0.8 L-BU	1957	Left Front Midrange Speaker Output (-)
D3	0.8 OG	1732	Courtesy Lamps Control
D4	0.5 PK	353	Instrument Panel Module Suppression Indicator Control (C99)
D5	0.35 PK/BK	780	Driver Door Lock Switch Lock Signal (AU3)

Pin	Wire Color	Circuit No.	Function
D6	0.35 OG/BK	781	Driver Door Lock Switch Unlock Signal (AU3)
D7	0.35 L-BU	244	Passenger Door Lock Switch Lock Control (AU3)
D8	0.35 D-BU	245	Passenger Door Lock Switch Unlock Control (AU3)

In-Line Harness Connector End Views – X319 – (C36/ENC) Rear Heater Switch Harness to Body Harness

Connector Part Information

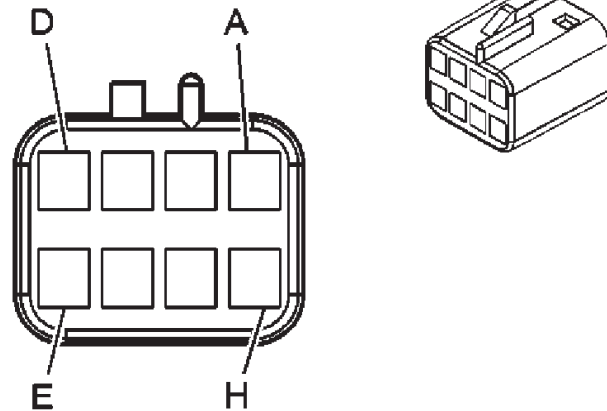

OEM: 12047886

Service: 12101822

Description: 8-Way F
Metri-Pack 150 Series (BK)

Terminal Part Information

Terminal/Tray: See Terminal Repair Kit

Core/Insulation Crimp: Pins: See Terminal Repair Kit

Release Tool/Test Probe: See Terminal Repair Kit

Pin	Wire Color	Circuit No.	Function
A	0.35 WH	1924	Auxiliary Blower Motor High Control
B	0.35 OG	1925	Auxiliary Blower Motor Medium Control
C	0.35 D-BU	1926	Auxiliary Blower Motor Low Control
D	0.35 BN/WH	230	Instrument Panel Lamps Dimming Control
E	0.35 BK	450	Ground
F-H	--	--	Not Used

Connector Part Information

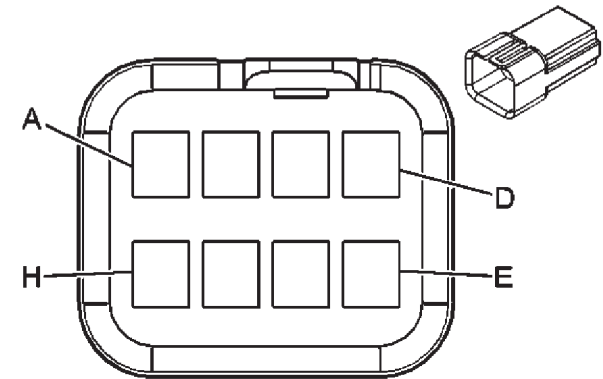

OEM: 12045688

Service: 12101827

Description: 8-Way F
Metri-Pack 150 Series (BK)

Terminal Part Information

Terminal/Tray: See Terminal Repair Kit

Core/Insulation Crimp: Pins: See Terminal Repair Kit

Release Tool/Test Probe: See Terminal Repair Kit

Pin	Wire Color	Circuit No.	Function
A	0.35 WH	1924	Auxiliary Blower Motor High Control
B	0.35 OG	1925	Auxiliary Blower Motor Medium Control
C	0.35 D-BU	1926	Auxiliary Blower Motor Low Control
D	0.35 BN/WH	230	Instrument Panel Lamps Dimming Control
E	0.35 BK	450	Ground
F-H	--	--	Not Used

In-Line Harness Connector End Views – X320 – (YF2/YF7) Body Harness to Upfitter Connection

Connector Part Information

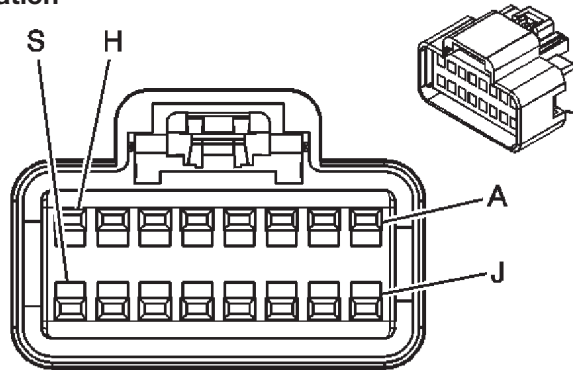

OEM: 15332177

Service: 15332177

Description: 16-Way M
GT 150 Series (BK)

Terminal Part Information

Terminal/Tray: See Terminal Repair Kit

Core/Insulation Crimp: See Terminal Repair Kit

Release Tool/Test Probe: See Terminal Repair Kit

Pin	Wire Color	Circuit No.	Function
A	--	1959	Left Rear Midrange Speaker Output (-)
B	--	1859	Left Rear Midrange Speaker Output (+)
C	--	1955	Right Rear Midrange Speaker Output (-)
D	--	1855	Right Rear Midrange Speaker Output (+)
E-N	--	--	Not Used
P	--	450	Ground
R	--	149	Courtesy Lamp Control
S	--	2209	Rear Park Lamps Control

Connector Part Information

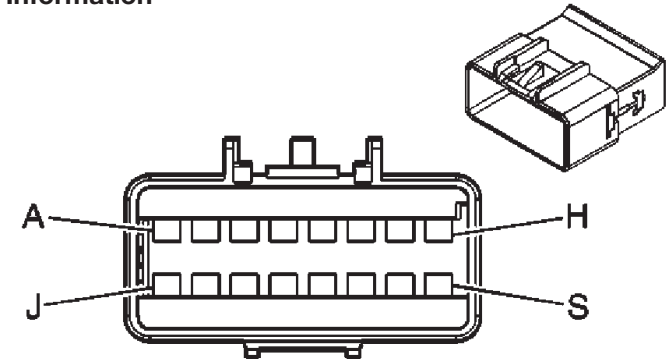

OEM: 15332182

Service: 15332182

Description: 16-Way M
GT 150 Series (BK)

Terminal Part Information

Terminal/Tray: See Terminal Repair Kit

Core/Insulation Crimp: See Terminal Repair Kit

Release Tool/Test Probe: See Terminal Repair Kit

Pin	Wire Color	Circuit No.	Function
A	1 WH	1959	Left Rear Midrange Speaker Output (-)
B	1 TN	1859	Left Rear Midrange Speaker Output (+)
C	1 OG	1955	Right Rear Midrange Speaker Output (-)
D	1 TN	1855	Right Rear Midrange Speaker Output (+)
E-N	--	--	Not Used
P	0.5 BK	450	Ground
R	0.5 D-BU/WH	149	Courtesy Lamp Control
S	0.5 BN	2209	Rear Park Lamps Control

In-Line Harness Connector End Views – X321 – (YF2/YF7) Upfitter Harness to Body Harness

Connector Part Information

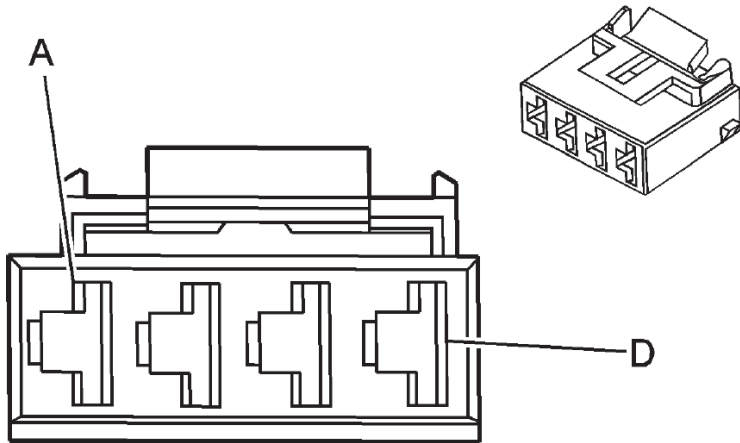

OEM: 12015664

Service: 12015664

Description: 4-Way F Metri-Pack
630 Series (BK)

Terminal Part Information

Terminal/Tray: See Terminal Repair Kit

Core/Insulation Crimp: See Terminal Repair Kit

Release Tool/Test Probe: See Terminal Repair Kit

Pin	Wire Color	Circuit No.	Function
A	--	1042	Battery Positive Voltage
B	--	541	Ignition Voltage
C	--	450	Ground
D	--	--	Not Used

Connector Part Information

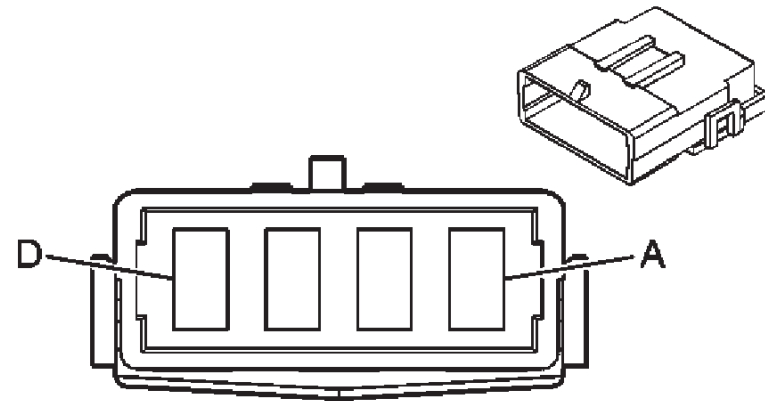

OEM: 12052623

Service: 15306008

Description: 4-Way M Metri-Pack
630 Series (BK)

Terminal Part Information

Terminal/Tray: See Terminal Repair Kit

Core/Insulation Crimp: See Terminal Repair Kit

Release Tool/Test Probe: See Terminal Repair Kit

Pin	Wire Color	Circuit No.	Function
A	5 RD/BK	1042	Battery Positive Voltage
B	5 BN	541	Ignition Voltage
C	5 BK	450	Ground
D	--	--	Not Used

In-Line Harness Connector End Views – X400 – (Passenger/Cargo) Right Rear Cargo Door to Body Harness

Connector Part Information

OEM: 15324054

Service: See Catalog

Description: 10-Way F Metri-Pac
150 (BK)

Terminal Part Information

Pins: D-E, H-K

Terminal/Tray: 12064971/5

Core/Insulation Crimp: E/C

Release Tool/Test Probe: 12094429/J-35616-14 (GN)

Pins: A-B, F-G

Terminal/Tray: 12047767/2

Core/Insulation Crimp: E/A

Release Tool/Test Probe: 12094429/J-35616-14 (GN)

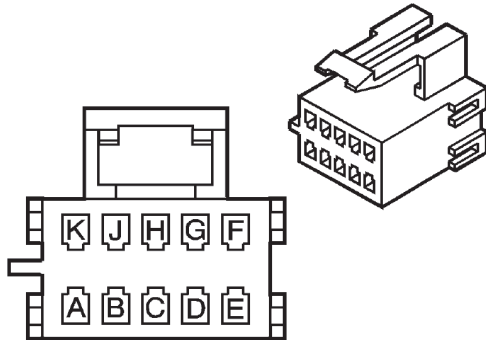

Pin	Wire Color	Circuit No.	Function
A	1 TN	1855	Right Rear Midrange Speaker Output (+)
B	1 OG	1955	Right Rear Midrange Speaker Output (-)
C	--	--	Not Used
D	0.35 BK/WH	1051	Ground
E	0.35 D-BU	245	Passenger Door Lock Switch Unlock Control (AU3)
F	1 GY	295	Door Lock Actuator Lock Control (AU3)
G	1 TN/BK	1095	Right Rear Door Lock Actuator Unlock Control (AU3)
H	0.35 L-GN	5926	Rear Access Open Switch Signal
J	0.35 PK/BK	1303	Cargo Door Ajar Switch Signal
K	0.35 L-BU	244	Passenger Door Lock Switch Lock Control (AU3)

Connector Part Information

OEM: 15324758

Service: See Catalog

Description: 10-Way M
Metri-Pack 150 (BK)

Terminal Part Information

Terminal/Tray: See Terminal Repair Kit

Core/Insulation Crimp: See Terminal Repair Kit

Release Tool/Test Probe: See Terminal Repair Kit

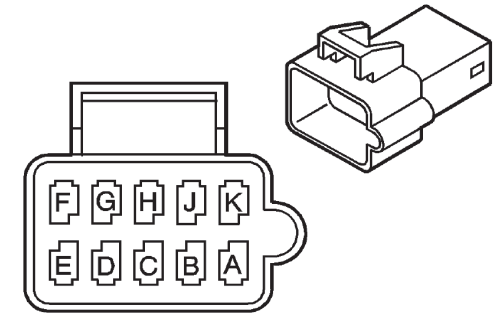

Pin	Wire Color	Circuit No.	Function
A	1 TN	1855	Right Rear Midrange Speaker Output (+)
B	1 OG	1955	Right Rear Midrange Speaker Output (-)
C	--	--	Not Used
D	1 BK/WH	1051	Ground
E	0.35 D-BU	245	Passenger Door Lock Switch Unlock Control (AU3)
F	1 GY	295	Door Lock Actuator Lock Control (AU3)
G	1 TN/BK	1095	Right Rear Door Lock Actuator Unlock Control (AU3)
H	0.35 L-GN	5926	Rear Access Open Switch Signal
J	0.35 PK/BK	1303	Cargo Door Ajar Switch Signal
K	0.35 L-BU	244	Passenger Door Lock Switch Lock Control (AU3)

In-Line Harness Connector End Views – X401 – (Passenger/Cargo) Left Tail Lamp Harness to Body Harness

Connector Part Information

OEM: 12064752

Service: 15305888

Description: 6-Way F Metri-Pack
280 Series (BK)

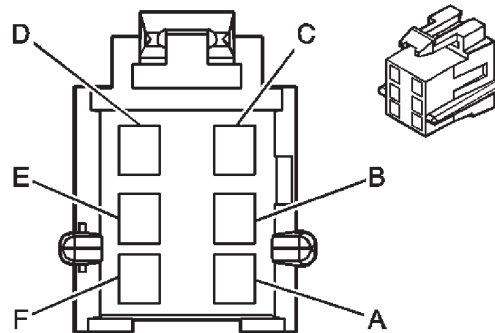

Terminal Part Information

Terminal/Tray: See Terminal Repair Kit

Core/Insulation Crimp: See Terminal Repair Kit

Release Tool/Test Probe: See Terminal Repair Kit

Pin	Wire Color	Circuit No.	Function
A	0.5 BN	2509	Left Rear Park Lamps Control
B	1 YE	618	Left Turn Signal Lamp Control
C	--	--	Not Used
D	0.8 BK	850	Ground
E	--	--	Not Used
F	0.8 L-GN	24	Backup Lamp Control

Connector Part Information

OEM: 12064754

Service: 12064754

Description: 6-Way M Metri-Pack
280 Series Self Lock (BK)

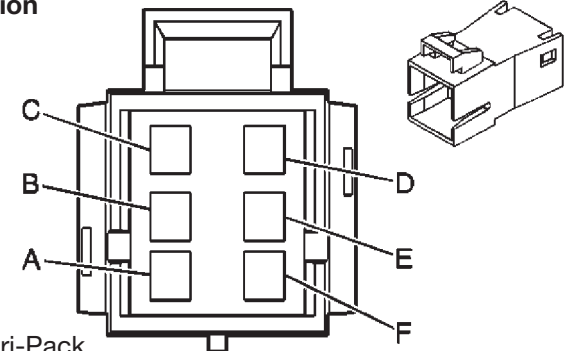

Terminal Part Information

Terminal/Tray: See Terminal Repair Kit

Core/Insulation Crimp: See Terminal Repair Kit

Release Tool/Test Probe: See Terminal Repair Kit

Pin	Wire Color	Circuit No.	Function
A	0.5 BN	2509	Left Rear Park Lamps Control
	0.5 BN	2509	Left Rear Park Lamps Control
B	1 YE	618	Left Turn Signal Lamp Control
C	--	--	Not Used
D	0.8 BK	850	Ground
E	--	--	Not Used
F	0.8 L-GN	24	Backup Lamp Control

In-Line Harness Connector End Views – X402 – (Passenger/Cargo) Right Tail Lamp Harness to Body Harness

Connector Part Information

OEM: 12064752

Service: 15305888

Description: 6-Way F Metri-Pack
280 Series (BK)

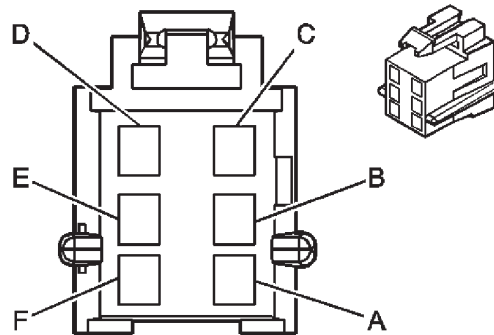

Terminal Part Information

Terminal/Tray: See Terminal Repair Kit

Core/Insulation Crimp: See Terminal Repair Kit

Release Tool/Test Probe: See Terminal Repair Kit

Pin	Wire Color	Circuit No.	Function
A	0.5 BN	2609	Right Rear Park Lamps Control/ Park Lamps Control
B	1 YE	619	Right Rear Turn Signal Lamp Control
C	--	--	Not Used
D	0.8 BK	1050	Ground
E	--	--	Not Used
F	0.8 L-GN	24	Backup Lamp Control

Connector Part Information

OEM: 12064754

Service: 15305872

Description: 6-Way M Metri-Pack
280 Series Self Lock (BK)

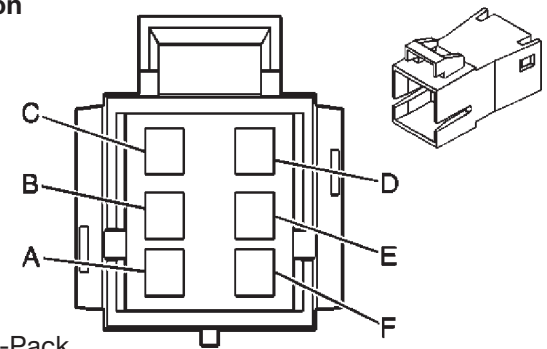

Terminal Part Information

Terminal/Tray: See Terminal Repair Kit

Core/Insulation Crimp: See Terminal Repair Kit

Release Tool/Test Probe: See Terminal Repair Kit

Pin	Wire Color	Circuit No.	Function
A	0.5 BN	2609	Right Rear Park Lamps Control/ Park Lamps Control
B	1 D-GN	619	Right Rear Turn Signal Lamp Control
C	--	--	Not Used
D	0.8 BK	1050	Ground
E	--	--	Not Used
F	0.8 L-GN	24	Backup Lamp Control

In-Line Harness Connector End Views – X405 – (Cutaway) Rear Lighting Connector to Chassis Harness

Connector Part Information

OEM: 15326660

Service: 88986262

Description: 10-Way F GT
280 5.8 Series Sealed (BK)

Terminal Part Information

Terminal/Tray: See Terminal Repair Kit

Core/Insulation Crimp: See Terminal Repair Kit

Release Tool/Test Probe: See Terminal Repair Kit

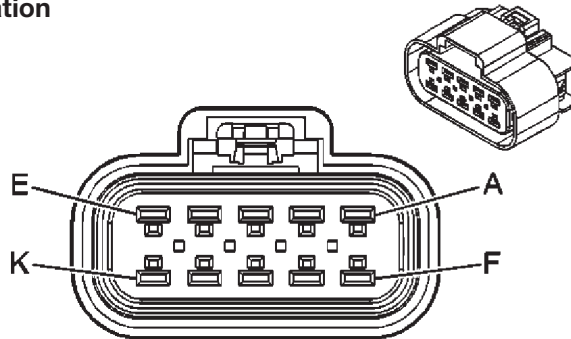

Connector Part Information

OEM: 15326661

Service: 15326661

Description: 10-Way M GT
280 5.8 Series Sealed (BK)

Terminal Part Information

Terminal/Tray: See Terminal Repair Kit

Core/Insulation Crimp: See Terminal Repair Kit

Release Tool/Test Probe: See Terminal Repair Kit

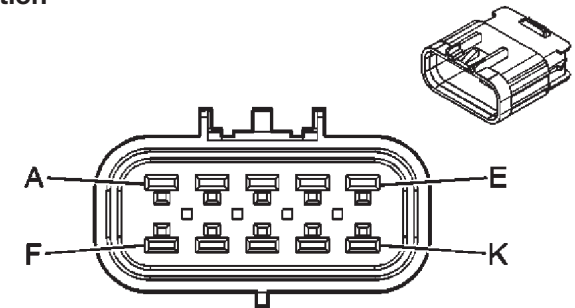

Pin	Wire Color	Circuit No.	Function
A-B	--	--	Not Used
C	1 WH	17	CHMSL Control
D	1 YE	618	Left Rear Turn Signal Lamp Control
E	1 D-GN	619	Right Rear Turn Signal Lamp Control
F	1 BN	2109	Trailer Park Lamps Control
G	1 BK	150	Ground
H	1 L-GN	1624	Trailer Backup Lamps Control
J	--	--	Not Used
K	0.8 D-BU/WH	149	Courtesy Lamp Control

Pin	Wire Color	Circuit No.	Function
A-B	--	--	Not Used
C	1 L-BU	1320	CHMSL Control
D	1 YE	618	Left Rear Turn Signal Lamp Control
E	1 D-GN	619	Right Rear Turn Signal Lamp Control
F	1 BN	2109	Trailer Park Lamps Control
G	1 BK	150	Ground
H	1 L-GN	1624	Trailer Backup Lamps Control
J	--	--	Not Used
K	0.8 D-BU/WH	149	Courtesy Lamp Control

In-Line Harness Connector End Views – X411 – (Passenger/Cargo) Left Rear Cargo Door to Body Harness

Connector Part Information

OEM: 12064752

Service: 12064752

Description: 6-Way F Metri-Pack
280 Series (BK)

Terminal Part Information

Pins: A-B

Terminal/Tray: 12034046/2

Core/Insulation Crimp: C/D

Release Tool/Test Probe: 12094430/J-35616-4A (PU)

Pins: D-E

Terminal Tray: 12015858/4

Core/Insulation Crimp: Pins: D : B/G

Core/insulation Crimp: Pins: E : F/G

Release Tool/Test Probe: 12094430/J-35616-4A (PU)

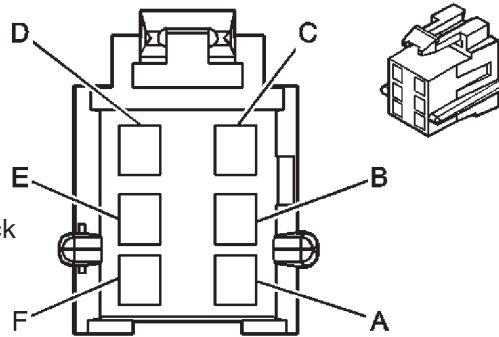

Pin	Wire Color	Circuit No.	Function
A	1 TN	1859	Left Rear Midrange Speaker Output (+)
B	1 WH	1959	Left Rear Midrange Speaker Output (-)
C	--	--	Not Used
D	5 PU	293	Rear Defog Element Control (C49)
E	3 BK	850	Ground (C49)
F	--	--	Not Used

Connector Part Information

OEM: 12064754

Service: 15305872

Description: 6-Way M Metri-Pack
280 Series Self Lock (BK)

Terminal Part Information

Terminal/Tray: See Terminal Repair Kit

Core/Insulation Crimp: See Terminal Repair Kit

Release Tool/Test Probe: See Terminal Repair Kit

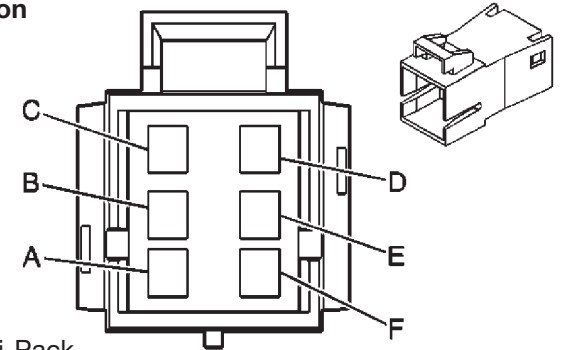

Pin	Wire Color	Circuit No.	Function
A	1 TN	1859	Left Rear Midrange Speaker Output (+)
B	1 WH	1959	Left Rear Midrange Speaker Output (-)
C	--	--	Not Used
D	5 PU	293	Rear Defog Element Control (C49)
E	3 BK	850	Ground (C49)
F	--	--	Not Used

In-Line Harness Connector End Views – X412 – (Passenger/Cargo) Right Rear Cargo Door to Body Harness

Connector Part Information

OEM: 12020014
Service: 12020014
Description: 3-Way F
Metri-Pack Connectors,
Mixed (280, 480) Series (BK)

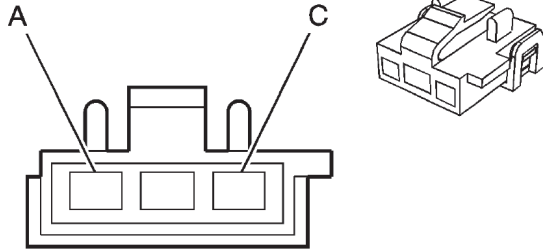

Terminal Part Information

Pins: A, C
Terminal/Tray: 12034046/2
Core/Insulation Crimp: E/A
Release Tool/Test Probe: 12094430/J-35616-4A (PU)

Pins: C
Terminal Tray: 12015858/4
Core/Insulation Crimp: F/G
Release Tool/Test Probe: 12094430/J-35616-4A (PU)

Pins: B
Terminal Tray: 12084595/2
Core/Insulation Crimp: B/G
Release Tool/Test Probe: 12094430/J-35616-4O (BU)

Pin	Wire Color	Circuit No.	Function
A	0.5 BN	2509	Left Rear Park Lamps Control
B	5 PU	293	Rear Defog Element Control (C49)
C	3 BK	1050	Ground (Passenger/Cargo with C49)
	0.5 BK	1050	Ground (Passenger/Cargo without C49)

Connector Part Information

OEM: 12045681
Service: 12045681
Description: 3-Way M Metri-Pack
280, 480 Series (BK)

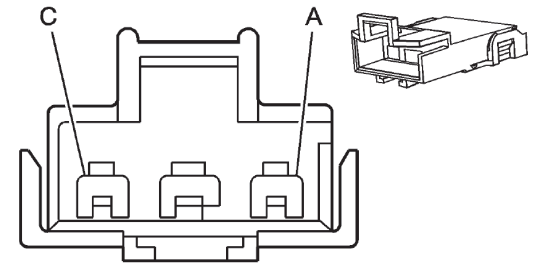

Terminal Part Information

Terminal/Tray: See Terminal Repair Kit
Core/Insulation Crimp: See Terminal Repair Kit
Release Tool/Test Probe: See Terminal Repair Kit

Pin	Wire Color	Circuit No.	Function
A	0.5 BN	2509	Left Rear Park Lamps Control
B	5 PU	293	Rear Defog Element Control (C49)
C	3 BK	1050	Ground

In-Line Harness Connector End Views – X415 – (Passenger/Cargo) Right Rear Speaker Harness to Body Harness

Connector Part Information

OEM: 12064760
Service: 12064760
Description: 4-Way F Metri-Pack
150 Series (BK)

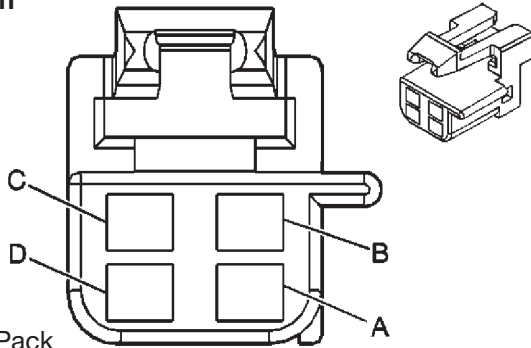

Terminal Part Information

Terminal/Tray: See Terminal Repair Kit
Core/Insulation Crimp: See Terminal Repair Kit
Release Tool/Test Probe: See Terminal Repair Kit

Pin	Wire Color	Circuit No.	Function
A	1 WH	1959	Left Rear Midrange Speaker Output (-)
B	1 TN	1859	Left Rear Midrange Speaker Output (+)
C	1 OG	1955	Right Rear Midrange Speaker Output (-)
D	1 TN	1855	Right Rear Midrange Speaker Output (+)

Connector Part Information

OEM: 12065658
Service: See Catalog
Description: 4-Way M Metri-Pack
150 Series (BK)

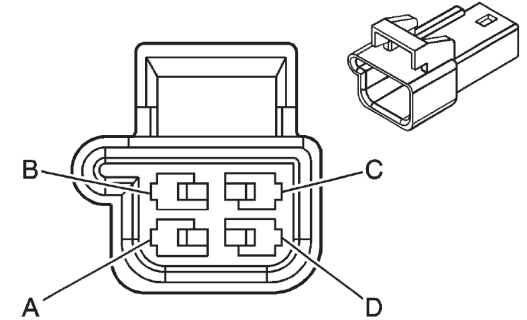

Terminal Part Information

Terminal/Tray: See Terminal Repair Kit
Core/Insulation Crimp: See Terminal Repair Kit
Release Tool/Test Probe: See Terminal Repair Kit

Pin	Wire Color	Circuit No.	Function
A	1 WH	1959	Left Rear Midrange Speaker Output (-)
B	1 TN	1859	Left Rear Midrange Speaker Output (+)
C	1 OG	1955	Right Rear Midrange Speaker Output (-)
D	1 TN	1855	Right Rear Midrange Speaker Output (+)

In-Line Harness Connector End Views – X417 – (Cargo w/o YF7) Dome Lamp Harness to Body Harness

Connector Part Information

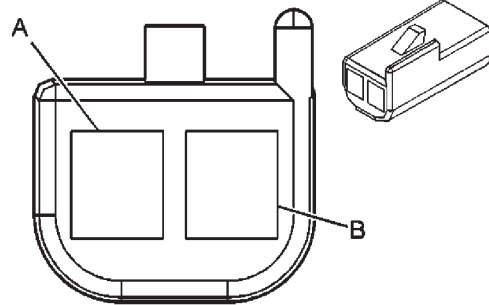

OEM: 12047662

Service: 12085535

Description: 2-Way F Metri-Pack
150 Series (BK)

Terminal Part Information

Terminal/Tray: See Terminal Repair Kit

Core/Insulation Crimp: See Terminal Repair Kit

Release Tool/Test Probe: See Terminal Repair Kit

Pin	Wire Color	Circuit No.	Function
A	0.8 D-BU/WH	149	Courtesy Lamp Control
B	0.5 BK	850	Ground

Connector Part Information

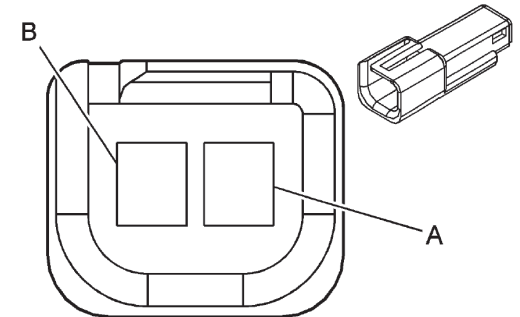

OEM: 12048457

Service: 12045481

Description: 2-Way M Metri-Pack
150 Series (BK)

Terminal Part Information

Terminal/Tray: See Terminal Repair Kit

Core/Insulation Crimp: See Terminal Repair Kit

Release Tool/Test Probe: See Terminal Repair Kit

Pin	Wire Color	Circuit No.	Function
A	0.8 D-BU/WH	149	Courtesy Lamp Control
B	0.5 BK	850	Ground

Miscellaneous Electrical Components – Generator Connectors – Location View

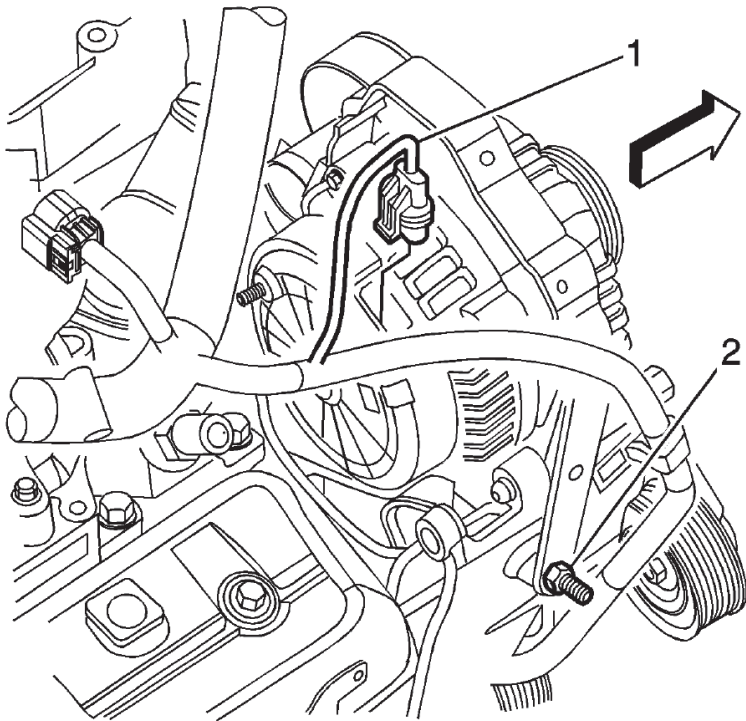

4.3L (LU3) Generator Connector

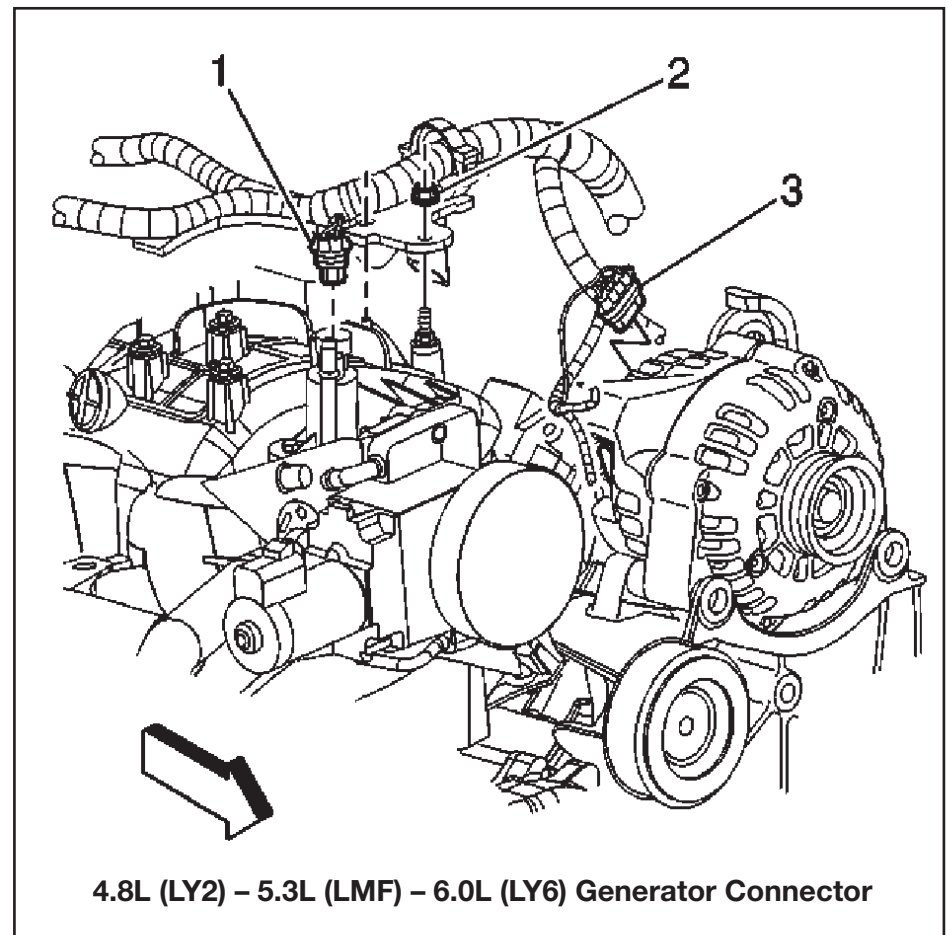

4.8L (LY2) – 5.3L (LMF) – 6.0L (LY6) Generator Connector

Miscellaneous Electrical Components – Generator Connectors – Connector End View – X1

Connector Part Information

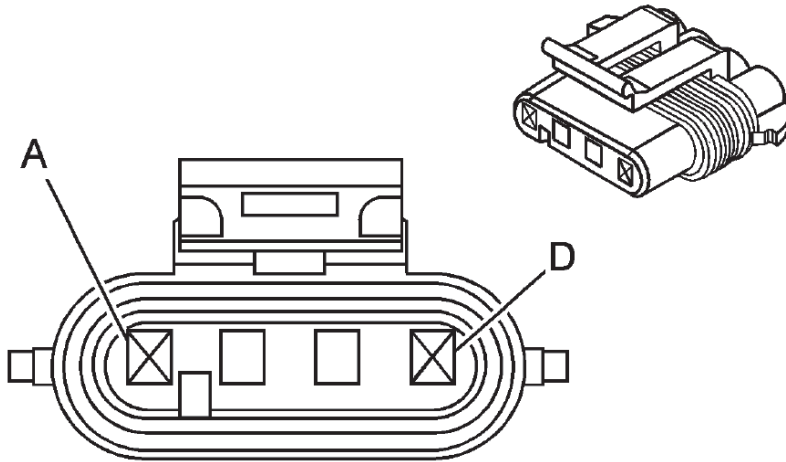

OEM: 15355066

Service: 15355066

Description: 2-Way F Metri-Pack 150 Series Sealed (BG)

Terminal Part Information

Terminal/Tray: 12048074/2

Core/Insulation Crimp: E/1

Release Tool/Test Probe: 12094429/J-35616-14 (GN)

Pin	Wire Color	Circuit No.	Function
A	--	--	Not Used
B	0.5 OG	225	Generator Turn On Signal (Gas)
	0.5 OG	225	Generator Turn On Signal (Diesel)
C	0.5 GY	23	Generator Field Duty Cycle Signal (Gas)
	0.8 GY	23	Generator Field Duty Cycle Signal (Diesel)
D	--	--	Not Used

Miscellaneous Electrical Components – Generator Connectors – Connector End View – X2

Connector Part Information

Terminal Part Information

Terminal/Tray: 15355282

Core/Insulation Crimp: N/A

Release Tool/Test Probe: Ring Terminal

Pin	Wire Color	Circuit No.	Function
A	19 RD	1	Battery Positive Voltage

Miscellaneous Electrical Components – Generator Connectors – Connector End View – Auxiliary X1 (KD9 with YF2)

Connector Part Information

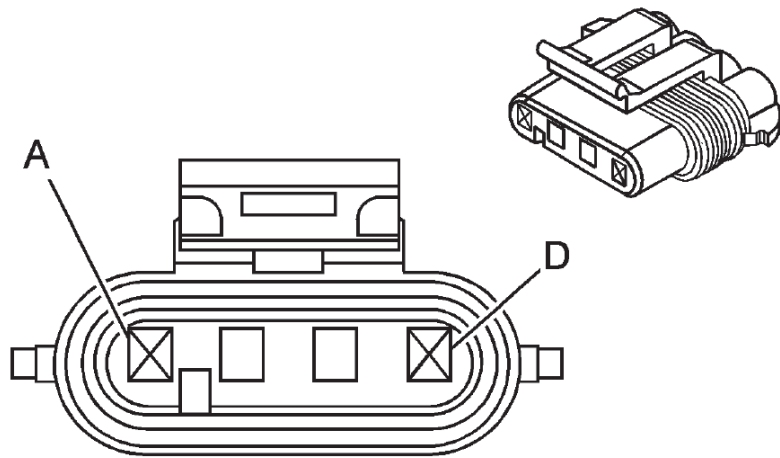

OEM: 15355066

Service: 15355066

Description: 2-Way F Metri-Pack 150 Series Sealed (BG)

Terminal Part Information

Pins: B

Terminal/Tray: 12048074/2

Core/Insulation Crimp: E/1

Release Tool/Test Probe: 12094429/J-35616-14 (GN)

Pin	Wire Color	Circuit No.	Function
A	--	--	Not Used
B	0.8 BN/WH	7076	Charge Indicator Control
C	--	--	Not Used
D	--	--	Not Used

Miscellaneous Electrical Components – Generator Connectors – Connector End View – Auxiliary X2 (KD9 with YF2)

Connector Part Information

Terminal Part Information

Terminal/Tray: 15355282

Core/Insulation Crimp: N/A

Release Tool/Test Probe: Ring Terminal

Pin	Wire Color	Circuit No.	Function
A	19 RD	1	Battery Positive Voltage

Section E – Frequently Asked Questions

1) In-Cab Power

- Battery – see page **B-48**
- Switched Ignition – see page **B-48**

2) Rear HVAC Control

- Ground Pin A of A/C Low Side Pressure Switch to simulate A/C compressor request.

3) Backup Alarm

- Disable perimeter lighting via Driver Information Control (DIC) (if equipped)
- Service calibration available through GM TechLine – see GM Dealer

4) Fast Idle

- See Bulletin #82 at: [http:// www.gmupfitter.com/publicat/bull/63135_FastIdle_UI_82_D3.pdf](http://www.gmupfitter.com/publicat/bull/63135_FastIdle_UI_82_D3.pdf)

5) Starter Interrupt

- Interrupt Circuit #6 (PURPLE) to starter motor solenoid

6) Park/Neutral

- 12V signal at Brake Shift Interlock Solenoid, Pin A, indicates in PARK/NEUTRAL. See page **B-75 & B-76**

7) I/P Panel Illumination for Auxiliary Switches

- Option 1: Access I/P Lamp Dimming Control, circuit #230 (BRN/WH), at connector X205. See pages **C-8 & C-14**
- Option 2: Access I/P Lamp Dimming Control, circuit #230 (BRN/WH), at BCM. See pages **B-1 & B-3**

8) Access to Park and Clearance Lamp Circuit

- Option 1: Connector X405, cavity F. Located inboard side of LH frame rail, just behind most rearward crossmember. See pages **C-9 & C-27**
- Option 2: Body Fuse Block (BBEC), connector X1. See pages **B-47 & B-53**

9) Horn Control

- Fuse #43 (horn control) is in underhood fuse block (UHBEC). See pages **B-35 & B-37**
- Horn Control at UHBEC Connector X1, Pin 53, circuit #29 (DK GRN). See page **B-41**

10) Park Brake Signal

- See connector located behind driver side kick panel. See pages **B-64 & B-65**

11) Starter Crank Signal

- Fuse #64 (starter solenoid) is in the underhood fuse block (UHBEC). See pages **B-35 & B-41**

12) Door Lock Signals

- Fuse #27 (front door lock). See pages **B-50, B-53, B-55, B-56**
- Fuse #31 (driver door unlock). See pages **B-50, B-53, B-55, B-56**