

# SPECIAL APPLICATIONS

<b>PICKUP BOX REMOVAL PROGRAM</b> .....	<b>PB— 1</b>
Alterations to Complete Vehicles .....	PB— 1
<b>CMVSS and FMVSS</b> .....	<b>PB— 3</b>
<b>Federal Motor Vehicle Safety Standards</b> .....	<b>PB— 4</b>
CMVSS 105 and FMVSS 105 – Hydraulic Brake Systems .....	PB— 4
CMVSS 105 and FMVSS 105 – Hydraulic and Electric Brake Systems.....	PB— 7
<b>CMVSS 105 and FMVSS 105 Allowable Center of Gravity Charts</b> .....	<b>PB— 9</b>
CMVSS 108 and FMVSS 108 – Lamps, Reflective Devices and Associated Equipment (Pickup and Utility) .....	PB— 16
CMVSS 108 and FMVSS 108 – Lamps, Reflective Devices and Associated Equipment (Chassis Cab).....	PB— 16
CMVSS 111 and FMVSS 111 – Rearview Mirrors.....	PB— 17
CMVSS 135 and FMVSS 135 – Hydraulic Brake Systems .....	PB— 18
<b>CMVSS 135 and FMVSS 135 Allowable Center of Gravity Charts</b> .....	<b>PB—20</b>
CMVSS 204 and FMVSS 204 – Steering Control Rearward Displacement .....	PB— 23
CMVSS 208 and FMVSS 208 – Occupant Crash Protection .....	PB— 23
CMVSS 212 and FMVSS 212 – Windshield Mounting .....	PB— 26
CMVSS 219 and FMVSS 219 – Windshield Zone Intrusion .....	PB— 27
CMVSS 301 and FMVSS 301 – Fuel System Integrity MPV’S, Trucks and Buses .....	PB— 28
<b>C/K Pickup Box Removal Program – TABLE A</b> .....	<b>PB—30</b>
<b>U.S. EPA, California, and Canadian Exhaust and Evaporative Emission Requirements and EPA Fuel Economy Regulations</b> .....	<b>PB—36</b>
Emission Related Components.....	PB— 36
Labels.....	PB— 37
<b>Pickup Box Removal Fuel Fill System Modifications for Gasoline Vehicles</b> .....	<b>PB—38</b>
<b>2011 C/K HDCS Cab Chassis Service Body Attachment Provisions</b> .....	<b>PB—39</b>
<b>2011 C/K Fuel Filler Assembly Service Part #’s</b> .....	<b>PB—40</b>
<b>2011 HDCS ‘Gas Vapor Sensor’ (shipped loose on ZW/9 Cab Chassis)</b> .....	<b>PB—41</b>
<b>ELECTRICAL INFORMATION...Refer to Electrical - Pickups and Chassis Cabs (Chevrolet Silverado &amp; GMC Sierra) and SUV Utilities (Chevrolet Tahoe &amp; Suburban, GMC Yukon &amp; Yukon XL)</b>	

## PICKUP BOX REMOVAL PROGRAM

### ***Alterations to Complete Vehicles***

Persons who alter complete (certified) Pickup Trucks by removal of the Pickup box should be aware that this type of activity would impose upon them the corresponding responsibility for ensuring that the units as sold are in compliance with all applicable safety and/or emissions (including noise and RFI) requirements. Specific questions concerning compliance or certification to these requirements should be directed to the vehicle alterer's legal counsel or the National Highway Traffic Safety Administration, the Environmental Protection Agency, the California Air Resources Board, or in Canada, the Ministry of Transport or the Canadian Department of Commerce.

The Environmental Protection Agency has provided an explanation of the policy they will follow regarding the modification by the secondary manufacturers of complete Light Duty Trucks prior to sale and delivery to the ultimate purchaser. This explanation is contained in a letter from C. N. Freed of the EPA to M.H. McBride of the Recreation Vehicle Industry Association, dated July 13, 1979. A portion of this letter states:

“...Secondary manufacturers are not manufacturers under the [Clean Air] Act when the following conditions are met:

1. The vehicles produced by a secondary manufacturer conform in all material respects to the design specification in the original manufacturer's application for certification (hereafter 'Application'); and
2. The weight of the vehicles produced by a secondary manufacturer, including the weight of fuel at nominal tank capacity, is no more than 500 lbs. above the maximum vehicle weight.”

No frontal area restrictions will apply to secondary manufacturers who comply with the conditions above. However, every vehicle sold to an ultimate purchaser must be covered by emission warranty mandated by section 207(a) of the Act. Secondary manufacturers who do not meet the above conditions will be considered manufacturers under the Act and will be required to ensure that the vehicles they produce are covered by a certificate of conformity.

The Maximum vehicle weight for a given vehicle is determined by:

- A) Subtracting 300 lbs. from the highest loaded vehicle weight (see 40 CFR 86.082-2 for loaded vehicle weight definition and the table at 40 CFR 86.129-94) associated with the test weight listed in the application for the vehicle, and
- B) Adding the weight of all options that are offered by the original manufacturer for the applicable truck line that were not included in the curb weight reported in the application.

In the case of mutually exclusive options, only the weight of the heavier option is to be used when computing the maximum vehicle weight.

***(Alterations – continued on next page)***

*(Alterations – continued from previous page)*

In addition, the California Air Resources Board has provided an explanation of the policy they will follow regarding the modification by the secondary manufacturers of complete Light Duty Trucks prior to sale and delivery to the ultimate purchaser. This explanation is contained in the California Exhaust Emission Standards and Test Procedures for 2001 and Subsequent Model Passenger Cars, Light Duty Trucks and Medium Duty Vehicles, adopted August 5, 1999, and dated May 28, 2004. A portion of this document states:

“Certification, if granted, is effective only for the vehicle/test group described in the original manufacturer’s certification application. Modifications by a secondary manufacturer to vehicles/engines shall be deemed not to increase emissions above the standards under which those vehicles/engines were certified and to be within the original certification if such modifications do not: (1) increase vehicle weight more than 10 percent above the curb weight, increase frontal area more than 10 percent, or result in a combination increase of weight plus frontal area of more than 14 percent; or (2) include changes in axle ratio, tire size, or tire type resulting in changes in the drive train ratio of more than 5 percent; or (3) include any modification to the emission control system. No originally certified vehicle/engine which is modified by a secondary manufacturer in a manner described in items (1) through (3) of the preceding sentence may be sold to an ultimate purchaser, offered or delivered for sale to an ultimate purchaser, or registered in California unless the modified vehicle/engine is certified by the state board in accordance with applicable test procedures to meet emission standards for the model year for which the vehicle/engine was originally certified. For the purposes of this subsection, “secondary manufacturer” means any person, other than the original manufacturer, who modifies a new motor vehicle prior to sale to the ultimate purchaser.”

Those who wish to remove the Pickup box from a Pickup Truck for the purpose of installing special equipment or another type of body should be further advised that a Pickup may require modification in one of the following areas. Before a decision is made to alter a C/K Pickup Model, please be advised of the following considerations:

**Vehicle:**

Analyze the vehicle specifications for product content. The option content of a particular vehicle will determine which if any of the five areas of modification might not be applicable to the vehicle alterations contemplated.

**Service Parts:**

The service parts and related service part number as outlined in the five areas of modification may be ordered through your local Chevrolet/GMC Dealer. Contact your Dealer’s Service Parts Representative for availability and price.

**Areas of Modification:**

1. Fuel filler neck assembly, housing, and ground strap.
2. Rear axle vent hose.
3. Tail lamp, tail lamp wiring harness and license plate bracket assembly.
4. Spare tire mounting.
5. Body pressure relief valve (see UI Bulletin #44).

## **CMVSS and FMVSS**

Compliance of Canadian and Federal Motor Vehicle Safety Standards will be affected by Upfitters removing Pickup Box and Rear Bumper to install a second unit body:

- MVSS 105 – Hydraulic brake (Vehicles greater than 3500 kg (7716 lb) GVWR)
- MVSS 108 – Lighting Equipment
- MVSS 111 – Rear View Mirrors
- MVSS 135 – Light Vehicle Brakes, applies to vehicles 3500 kg (7716 lb) GVWR or less
- MVSS 204 – Steering Control Rear Displacement
- MVSS 208 – Occupant Crash Protection
- MVSS 219 – Windshield Zone Intrusion 4536 kg (10,000 lb) or less
- MVSS 301 – Fuel System Integrity, trucks

## Federal Motor Vehicle Safety Standards

### CMVSS 105 and FMVSS 105 – HYDRAULIC BRAKE SYSTEMS

**TYPE 1** The following statement is applicable to all types of incomplete vehicles contained in this document with a greater than 3500 kg (7,716 lb) GVWR, (unless otherwise noted on the cover).

This incomplete vehicle when completed will conform to CMVSS 105 and FMVSS 105 provided it is completed in accordance with the following specific conditions by the (immediate and) final stage manufacturer:

A. Providing no alterations are made which affect the function, physical, chemical, or mechanical properties, environment, location or vital spatial clearances of the components, assemblies or systems including but not limited to those listed below:

Anti-Lock Brake System	Hydraulic brake lines, fittings and routings
Brake assemblies and components (service /parking) – (power boosters, master cylinder, wheel cylinder, calipers, wheel speed sensor, wheel speed sensor wiring, brake lining, etc.)	Hydraulic brake valves and components
Brake pedal, brake switch, parking brake hand – lever or park brake switch and related mechanical components	Master cylinder-warning statement
Brake system electrical controls and logic	Parking brake actuator and related – mechanical components
Gauges and warning devices, and statements	Power steering or vacuum lines and routing
Hydraulic brake fluid and reservoirs	Power steering or vacuum pump
	Tires and Wheels
	Vacuum brake lines, fittings and routings
	Vehicle wiring harnesses
	Wheelbases

B. GVWR, GAWR front and rear weight ratings as listed on the incomplete vehicle label affixed to the front cover of this document must not be exceeded.

C. The center of gravity of the total vehicle falls within the areas referenced on the “ALLOWABLE CENTER OF GRAVITY CHART” that follows. Instructions for determining the allowable center of gravity variation are listed below:

These charts detail the envelope of allowable center of gravity variation for completed vehicles. This is significant for the lightly loaded portion of FMVSS 105, which is defined as curb plus 181.4 kg (400 lb) distributed in the driver-passenger area of the vehicle for vehicles with GVWR of 4536 kg (10,000 lb) or less or as curb plus 226.8 kg (500 lb) distributed in the driver-passenger area of the vehicle for vehicles with GVWR greater than 4536 kg (10,000 lb).

The lightly loaded center of gravity complete vehicles needs to be restricted so it will meet FMVSS 105 stopping distances. The laden center of gravity does not need to be specified as it is controlled within the CMVSS 105 and FMVSS 105 test procedure by specific instructions as to how ballast is to be placed (while height is not controlled, it is assumed that for test purposes it would be reasonable).

***(CMVSS 105 and FMVSS 105 – continued on next page)***

(CMVSS 105 and FMVSS 105 – continued from previous page)

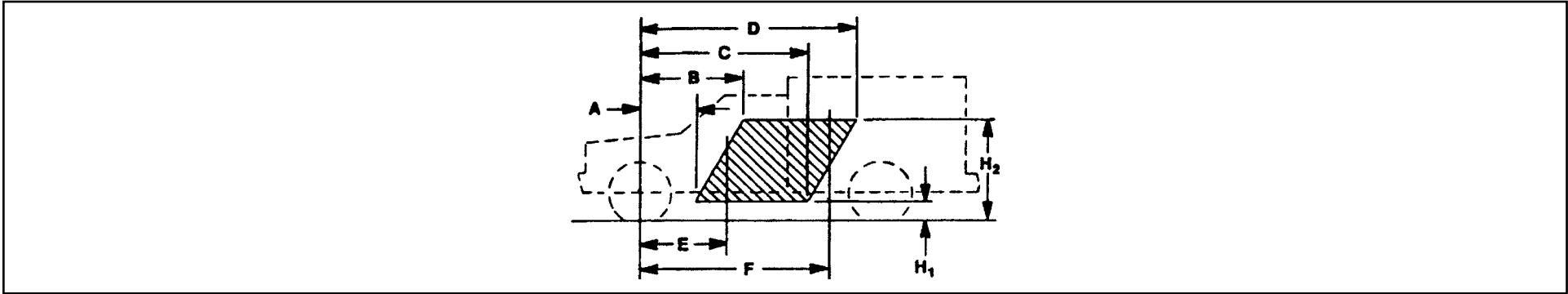

C/G of vehicle in CMVSS or FMVSS unladen condition [Curb + 181.4 kg. (400 lb) or Curb + 226.8 kg. (500 lb) as defined by CMVSS 105 and FMVSS 105] must be inside shaded area – that is, the C/G must be within the trapezoid formed by the coordinates A, B, C, D, H<sub>1</sub>, & H<sub>2</sub>, plus the C/G must be to the rear of vertical line E and forward of vertical line F.

For Body Builder's use, the center of gravity location can be approximated by the following formula:

$$d = \frac{[W_{rc} + W_{rb} + [(H_p)(W_p)/WB]] WB}{W_t}$$

$$h = \frac{[h_1 W_c + h_2 W_b + (h_3)(W_p)]}{W_t}$$

d = horizontal distance from front wheels to completed vehicle center of gravity cm (in)

h = vertical distance from ground to completed vehicle center of gravity cm (in)

W<sub>rc</sub> = rear component of bare chassis weight kg (lb)

W<sub>rb</sub> = rear component of body weight kg (lb)

WB = vehicle wheelbase cm (in)

W<sub>t</sub> = total weight of chassis and body kg (lbs) plus 181.4 kg (400 lb) for vehicles with GVWR of 4536 kg (10,000 lb) or less

W<sub>t</sub> = total weight of chassis and body kg (lbs) plus 226.8 kg (500 lb) for vehicles with GVWR greater than 4536 kg (10,000 lb)

h<sub>1</sub> = center of gravity height from ground of the bare chassis = 71.1 cm (28 in)

W<sub>c</sub> = total weight of chassis kg (lb)

h<sub>2</sub> = center of gravity height of body from ground cm (in)

W<sub>b</sub> = total weight of body kg (lb)

W<sub>p</sub> = 181.4 kg (400 lb) amount from lightly loaded definition that is evenly distributed in driver-passenger area of vehicle for vehicles with GVWR of 4536 kg (10,000 lb) or less

W<sub>p</sub> = 226.8 kg (500 lb) amount from lightly loaded definition that is evenly distributed in driver-passenger area of vehicle for vehicles with GVWR greater than 4536 kg (10,000 lb)

(CMVSS 105 and FMVSS 105 – continued on next page)

*(CMVSS 105 and FMVSS 105 – continued from previous page)*

- $H_p$  = 146.7 cm (57.76 in) horizontal distance from front axle to center of gravity of 181.4 kg (400 lb) or 226.8 kg (500 lb) evenly distributed in driver-passenger area of vehicle
- $h_3$  = 94.8 cm (37.32 in) vertical center of gravity height of 181.4 kg (400 lb) evenly distributed in driver-passenger area for vehicles with 3900 kg (8600 lb) GVWR
- $h_3$  = 99.9 cm (39.33 in) vertical center of gravity height of 181.4 kg (400 lb) evenly distributed in driver-passenger area for vehicles with 3856, 4173 and 4491 kg (8500, 9200 and 9900 lb) GVWR
- $h_3$  = 99.9 cm (39.33 in) vertical center of gravity height of 226.8 kg (500 lb) evenly distributed in driver-passenger area for vehicles with 5171 - 5443 kg (11,400 - 12,000 lb) GVWR

**CMVSS 105 and FMVSS 105 – HYDRAULIC AND ELECTRIC BRAKE SYSTEMS**  
**Applies to all types of Incomplete Vehicles Contained in this Document**  
**Greater than 3500 kg (7,716 lb) GVWR**

**TYPE 2** The following statement is applicable to all types of Incomplete Vehicles contained in this document with a greater than 3500 kg (7,716 lb) GVWR, (unless otherwise noted on the cover).

This incomplete vehicle when completed will conform to CMVSS 105 and FMVSS 105 provided it is completed in accordance with the following specific conditions by the (intermediate and) final stage manufacturer:

- A. Providing no alterations are made which affect the function, physical, chemical, or mechanical properties, environment, location or vital spatial clearances of the components, assemblies or systems, as manufactured by General Motors, including but not limited to those listed below (if equipped):

Anti-Lock Brake System	Hydraulic brake lines, fittings and routings
Brake assemblies and components (service/ parking) - (power boosters, master cylinder, wheel cylinder, calipers, wheel speed sensor, wheel speed sensor wiring, brake lining, etc.)	Hydraulic brake valves and components
Brake pedal, brake switch, parking brake hand lever or park brake switch and related mechanical components	Master cylinder-warning statement
Brake system electrical controls and logic	Parking brake actuator and related mechanical components
Gauges and warning devices, and statements	Power steering or vacuum lines and routing
Hydraulic brake fluid and reservoirs	Power steering or vacuum pump
	Tires and Wheels
	Vacuum brake lines, fittings and routings
	Vehicle wiring harnesses
	Wheelbases

- B. GVWR, GAWR front and rear weight ratings as listed on the Incomplete Vehicle Label affixed to the front cover of this document must not be exceeded.
- C. The center of gravity of the total vehicle falls within the areas referenced on the “ALLOWABLE CENTER OF GRAVITY CHART” that follows. Instructions for determining the allowable center of gravity variation are listed below:

These charts detail the envelope of allowable center of gravity variation for completed vehicles. This is significant for the lightly loaded portion of FMVSS 105, which is defined as curb plus 181.4 kg (400 lb) distributed in the driver-passenger area of the vehicle for vehicles with GVWR of 4536 kg (10,000 lb) or less or as curb plus 226.8 kg (500 lb) distributed in the driver-passenger area of the vehicle for vehicles with GVWR greater than 4536 kg (10,000 lb).

The lightly loaded center of gravity of complete vehicles needs to be restricted so it will meet FMVSS 105 stopping distances. The laden center of gravity does not need to be specified as it is controlled within the CMVSS 105 and FMVSS 105 test procedure by specific instructions as to how ballast is to be placed (while height is not controlled, it is assumed that for test purposes it would be reasonable).



**CMVSS 105 and FMVSS 105 – HYDRAULIC AND ELECTRIC BRAKE SYSTEMS**  
**Applies to all types of Incomplete Vehicles Contained in this Document**  
**Greater than 3500 kg (7,716 lb) GVWR**

For Body Builder's use, the center of gravity location can be approximated by the following formula:

$$d = \frac{[Wrc + Wrb + [(Hp)(Wp)/WB]] WB}{Wt}$$

$$h = \frac{[h1Wc + h2Wb + (h3)(Wp)]}{Wt}$$

d = horizontal distance from front wheels to completed vehicle center of gravity mm (in)

h = vertical distance from ground to completed vehicle center of gravity mm (in)

Wrc = rear component of Chassis weight kg (lb)

Wrb = rear component of body weight kg (lb)

WB = vehicle wheelbase mm (in)

Wt = total weight of chassis and body kg (lb) plus 181.4 kg (400 lb) for vehicles with GVWR of 4536 kg (10,000 lb) or less.

Wt = total weight of chassis and body kg (lb) plus 226.8 kg (500 lb) for vehicles with GVWR greater than 4536 kg (10,000 lb).

h1 = center of gravity height from ground of the Bare Chassis = 743 mm (29.25 in)

Wc = total weight of Chassis kg (lb)

h2 = center of gravity height of body from ground mm (in)

Wb = total weight of body kg (lb)

Wp = 181.4 kg (400 lb) Amount from lightly loaded definition that is evenly distributed in driver-passenger area of vehicle for vehicles with GVWR of 4536 kg (10,000 lb) or less.

Wp = 226.8 kg (500 lb) Amount from lightly loaded definition that is evenly distributed in driver-passenger area of vehicle for vehicles with GVWR greater than 4536 kg (10,000 lb).

Hp = 1482 mm (58.35 in) Horizontal distance from front axle to center of gravity of 181.4 kg (400 lb) or 226.8 kg (500 lb) evenly distributed in driver-passenger area of vehicle.

h3 = 1013 mm (39.88 in) Vertical center of gravity height of 181.4 kg (400 lb) evenly distributed in driver-passenger area for vehicles with GVWR of 4536 kg (10,000 lb) or less.

h3 = 1013 mm (39.88 in) Vertical center of gravity height of 226.8 kg (500 lb) evenly distributed in driver-passenger area for vehicles with GVWR greater than 4536 kg (10,000 lb).

## CMVSS 105 and FMVSS 105 ALLOWABLE CENTER OF GRAVITY CHARTS

Model	GVWR kg (lb)	Brake System	Wheel- Base mm (in)	Rear Wheel	Incomplete, Pickup Box Removal, or Snow Plow Prep Package Vehicles							
					Coordinates of Allowable C/G Variation at CMVSS/FMVSS Unladen, Curb Weight + 181.4 kg (400 lb) or 226.8 kg (500 lb) as defined by CMVSS 105 and FMVSS 105						Fwd C/G Limit mm (in)	RRwd C/G Limit mm (in)
					mm (in)						E	F
H <sub>1</sub>	H <sub>2</sub>	A	B	C	D							
C20743	4309 (9500)	J95	3904 (153.7)	SRW	304.8 (12.0)	1219.2 (48.0)	1288 (50.7)	1542 (60.7)	2785 (109.6)	3039 (119.6)	1288 (50.7)	2733 (107.6)
C20743	4491 (9900)	J95	3904 (153.7)	SRW	304.8 (12.0)	1219.2 (48.0)	1288 (50.7)	1542 (60.7)	2785 (109.6)	3039 (119.6)	1288 (50.7)	2733 (107.6)
C20743	4536 (10,000)	J95	3904 (153.7)	SRW	304.8 (12.0)	1219.2 (48.0)	1288 (50.7)	1542 (60.7)	2785 (109.6)	3039 (119.6)	1288 (50.7)	2733 (107.6)
C20753	4309 (9500)	J95	3662 (144.2)	SRW	304.8 (12.0)	1219.2 (48.0)	1213 (47.8)	1467 (57.8)	2618 (103.1)	2871 (113.0)	1209 (47.6)	2564 (100.9)
C20753	4491 (9900)	J95	3662 (144.2)	SRW	304.8 (12.0)	1219.2 (48.0)	1213 (47.8)	1467 (57.8)	2618 (103.1)	2871 (113.0)	1209 (47.6)	2564 (100.9)
C20753	4536 (10,000)	J95	3662 (144.2)	SRW	304.8 (12.0)	1219.2 (48.0)	1213 (47.8)	1467 (57.8)	2618 (103.1)	2871 (113.0)	1209 (47.6)	2564 (100.9)
C20903	4218 (9300)	J95	3395 (133.7)	SRW	304.8 (12.0)	1219.2 (48.0)	1131 (44.5)	1385 (54.5)	2433 (95.8)	2687 (105.8)	1120 (44.1)	2377 (93.6)
C20903	4491 (9900)	J95	3395 (133.7)	SRW	304.8 (12.0)	1219.2 (48.0)	1131 (44.5)	1385 (54.5)	2433 (95.8)	2687 (105.8)	1120 (44.1)	2377 (93.6)
C20903	4536 (10,000)	J95	3395 (133.7)	SRW	304.8 (12.0)	1219.2 (48.0)	1131 (44.5)	1385 (54.5)	2433 (95.8)	2687 (105.8)	1120 (44.1)	2377 (93.6)
C20943	4309 (9500)	J95	4259 (157.7)	SRW	304.8 (12.0)	1219.2 (48.0)	1397 (55.0)	1651 (65.0)	3031 (119.3)	3284 (129.3)	1406 (55.4)	2982 (117.4)
C20943	4491 (9900)	J95	4259 (157.7)	SRW	304.8 (12.0)	1219.2 (48.0)	1397 (55.0)	1651 (65.0)	3031 (119.3)	3284 (129.3)	1406 (55.4)	2982 (117.4)
C20943	4536 (10,000)	J95	4259 (157.7)	SRW	304.8 (12.0)	1219.2 (48.0)	1397 (55.0)	1651 (65.0)	3031 (119.3)	3284 (129.3)	1406 (55.4)	2982 (117.4)
C20953	4309 (9500)	J95	4017 (158.2)	SRW	304.8 (12.0)	1219.2 (48.0)	1323 (52.1)	1576 (62.0)	2863 (112.7)	3117 (122.7)	1326 (52.2)	2812 (110.7)

## CMVSS 105 and FMVSS 105 ALLOWABLE CENTER OF GRAVITY CHARTS

Model	GVWR kg (lb)	Brake System	Wheel- Base mm (in)	Rear Wheel	Incomplete, Pickup Box Removal, or Snow Plow Prep Package Vehicles							
					Coordinates of Allowable C/G Variation at CMVSS/FMVSS Unladen, Curb Weight + 181.4 kg (400 lb) or 226.8 kg (500 lb) as defined by CMVSS 105 and FMVSS 105 mm (in)						Fwd C/G Limit mm (in)	RRwd C/G Limit mm (in)
					H <sub>1</sub>	H <sub>2</sub>	A	B	C	D	E	F
C20953	4491 (9900)	J95	4017 (158.2)	SRW	304.8 (12.0)	1219.2 (48.0)	1323 (52.1)	1576 (62.0)	2863 (112.7)	3117 (122.7)	1326 (52.2)	2812 (110.7)
C20953	4536 (10,000)	J95	4017 (158.2)	SRW	304.8 (12.0)	1219.2 (48.0)	1323 (52.1)	1576 (62.0)	2863 (112.7)	3117 (122.7)	1326 (52.2)	2812 (110.7)
C30743	4536 (10,000)	J95	3904 (153.7)	SRW	304.8 (12.0)	1219.2 (48.0)	1288 (50.7)	1542 (60.7)	2785 (109.6)	3039 (119.6)	1288 50.7	2733 (107.6)
C30743	4763 (10,500)	J95	3904 (153.7)	SRW	304.8 (12.0)	1219.2 (48.0)	1074 (42.3)	1286 (50.6)	2971 (117.0)	3182 (125.3)	1171 (46.1)	2928 (115.3)
C30743	5035 (11,100)	J95	3904 (153.7)	SRW	304.8 (12.0)	1219.2 (48.0)	1074 (42.3)	1286 (50.6)	2971 (117.0)	3182 (125.3)	1171 (46.1)	2928 (115.3)
C30903	4717 (10,400)	J95	3395 (133.7)	SRW	304.8 (12.0)	1219.2 (48.0)	943 (37.1)	1155 (45.5)	2593 (102.1)	2804 (110.4)	1019 (40.1)	2547 (100.3)

## CMVSS 105 and FMVSS 105 ALLOWABLE CENTER OF GRAVITY CHARTS

Model	GVWR kg (lb)	Brake System	Wheel- Base mm (in)	Rear Wheel	Incomplete, Pickup Box Removal, or Snow Plow Prep Package Vehicles							
					Coordinates of Allowable C/G Variation at CMVSS/FMVSS Unladen, Curb Weight + 181.4 kg (400 lb) or 226.8 kg (500 lb) as defined by CMVSS 105 and FMVSS 105						Fwd C/G Limit mm (in)	RRwd C/G Limit mm (in)
					H <sub>1</sub>	H <sub>2</sub>	A	B	C	D	E	F
C30903	5035 (11,100)	J95	3395 (133.7)	SRW	304.8 (12.0)	1219.2 (48.0)	943 (37.1)	1155 (45.5)	2593 (102.1)	2804 (110.4)	1019 (40.1)	2547 (100.3)
C30903	5670 (12,500)	J96	3395 (133.7)	DRW	304.8 (12.0)	1219.2 (48.0)	943 (37.1)	1155 (45.5)	2593 (102.1)	2804 (110.4)	1019 (40.1)	2547 (100.3)
C30903	5806 (12,800)	J96	3395 (133.7)	DRW	304.8 (12.0)	1219.2 (48.0)	943 (37.1)	1155 (45.5)	2593 (102.1)	2804 (110.4)	1019 (40.1)	2547 (100.3)
C30903	5897 (13,000)	J96	3395 (133.7)	DRW	304.8 (12.0)	1219.2 (48.0)	943 (37.1)	1155 (45.5)	2593 (102.1)	2804 (110.4)	1019 (40.1)	2547 (100.3)
C30903	6078 (13,400)	J96	3395 (133.7)	DRW	304.8 (12.0)	1219.2 (48.0)	943 (37.1)	1155 (45.5)	2593 (102.1)	2804 (110.4)	1019 (40.1)	2547 (100.3)
C30943	4536 (10,000)	J95	4259 (157.7)	SRW	304.8 (12.0)	1219.2 (48.0)	1397 (55.0)	1651 (65.0)	3031 (119.3)	3284 (129.3)	1406 (55.4)	2982 (117.4)
C30943	4853 (10,700)	J95	4259 (157.7)	SRW	304.8 (12.0)	1219.2 (48.0)	1165 (45.9)	1377 (54.2)	3235 (127.4)	3446 (135.7)	1278 (50.3)	3195 (125.8)
C30943	5171 (11,400)	J95	4259 (157.7)	SRW	304.8 (12.0)	1219.2 (48.0)	1165 (45.9)	1377 (54.2)	3235 (127.4)	3446 (135.7)	1278 (50.3)	3195 (125.8)
C30943	5897 (13,000)	J96	4259 (157.7)	DRW	304.8 (12.0)	1219.2 (48.0)	1165 (45.9)	1377 (54.2)	3235 (127.4)	3446 (135.7)	1278 (50.3)	3195 (125.8)
C30953	4536 (10,000)	J95	4017 (158.2)	SRW	304.8 (12.0)	1219.2 (48.0)	1323 (52.1)	1576 (62.0)	2863 (112.7)	3117 (122.7)	1326 (52.2)	2812 (110.7)
C30953	4853 (10,700)	J95	4017 (158.2)	SRW	304.8 (12.0)	1219.2 (48.0)	1103 (43.4)	1315 (51.8)	3055 (120.3)	3266 (128.6)	1205 (47.4)	3013 (118.6)
C30953	5080 (11,200)	J95	4017 (158.2)	SRW	304.8 (12.0)	1219.2 (48.0)	1103 (43.4)	1315 (51.8)	3055 (120.3)	3266 (128.6)	1205 (47.4)	3013 (118.6)
C30953	5897 (13,000)	J96	4017 (158.2)	DRW	304.8 (12.0)	1219.2 (48.0)	1103 (43.4)	1315 (51.8)	3055 (120.3)	3266 (128.6)	1205 (47.4)	3013 (118.6)

## CMVSS 105 and FMVSS 105 ALLOWABLE CENTER OF GRAVITY CHARTS

Model	GVWR kg (lb)	Brake System	Wheel- Base mm (in)	Rear Wheel	Incomplete, Pickup Box Removal, or Snow Plow Prep Package Vehicles							
					Coordinates of Allowable C/G Variation at CMVSS/FMVSS Unladen, Curb Weight + 181.4 kg (400 lb) or 226.8 kg (500 lb) as defined by CMVSS 105 and FMVSS 105 mm (in)						Fwd C/G Limit mm (in)	RRwd C/G Limit mm (in)
					H <sub>1</sub>	H <sub>2</sub>	A	B	C	D	E	F
C31003	5987 (13,200)	J90	3493 (137.5)	DRW	304.8 (12.0)	1219.2 (48.0)	968 (38.1)	1180 (46.5)	2441 (96.1)	2759 (108.6)	1048 (41.3)	2619 (103.1)
C31003	5987 (13,200)	J96	3493 (137.5)	DRW	304.8 (12.0)	1219.2 (48.0)	968 (38.1)	1180 (46.5)	2666 (105.0)	2877 (113.3)	1048 (41.3)	2619 (103.1)
C31043	5987 (13,200)	J96	4356 (171.5)	DRW	304.8 (12.0)	1219.2 (48.0)	1190 (46.9)	1402 (55.2)	3307 (130.2)	3518 (138.5)	1307 (51.5)	3267 (128.6)
C31403	5987 (13,200)	J96	4115 (162.0)	DRW	304.8 (12.0)	1219.2 (48.0)	1128 (44.4)	1340 (52.8)	3128 (123.1)	3339 (131.5)	1234 (48.6)	3086 (121.5)
K20743	4309 (9500)	J95	3904 (153.7)	SRW	304.8 (12.0)	1219.2 (48.0)	1288 (50.7)	1542 (60.7)	2785 (109.6)	3039 (119.6)	1288 50.7)	2733 (107.6)
K20743	4491 (9900)	J95	3904 (153.7)	SRW	304.8 (12.0)	1219.2 (48.0)	1288 (50.7)	1542 (60.7)	2785 (109.6)	3039 (119.6)	1288 50.7)	2733 (107.6)
K20743	4536 (10,000)	J95	3904 (153.7)	SRW	304.8 (12.0)	1219.2 (48.0)	1288 (50.7)	1542 (60.7)	2785 (109.6)	3039 (119.6)	1288 50.7)	2733 (107.6)
K20753	4309 (9500)	J95	3662 (144.2)	SRW	304.8 (12.0)	1219.2 (48.0)	1213 (47.8)	1467 (57.8)	2618 (103.1)	2871 (113.0)	1209 (47.6)	2564 (100.9)
K20753	4491 (9900)	J95	3662 (144.2)	SRW	304.8 (12.0)	1219.2 (48.0)	1213 (47.8)	1467 (57.8)	2618 (103.1)	2871 (113.0)	1209 (47.6)	2564 (100.9)

## CMVSS 105 and FMVSS 105 ALLOWABLE CENTER OF GRAVITY CHARTS

Model	GVWR kg (lb)	Brake System	Wheel- Base mm (in)	Rear Wheel	Incomplete, Pickup Box Removal, or Snow Plow Prep Package Vehicles							
					Coordinates of Allowable C/G Variation at CMVSS/FMVSS Unladen, Curb Weight + 181.4 kg (400 lb) or 226.8 kg (500 lb) as defined by CMVSS 105 and FMVSS 105 mm (in)						Fwd C/G Limit mm (in)	RRwd C/G Limit mm (in)
					H <sub>1</sub>	H <sub>2</sub>	A	B	C	D	E	F
K20753	4536 (10,000)	J95	3662 (144.2)	SRW	304.8 (12.0)	1219.2 (48.0)	1213 (47.8)	1467 (57.8)	2618 (103.1)	2871 (113.0)	1209 (47.6)	2564 (100.9)
K20903	4309 (9500)	J95	3395 (133.7)	SRW	304.8 (12.0)	1219.2 (48.0)	1131 (44.5)	1385 (54.5)	2433 (95.8)	2687 (105.8)	1120 (44.1)	2377 (93.6)
K20903	4491 (9900)	J95	3395 (133.7)	SRW	304.8 (12.0)	1219.2 (48.0)	1131 (44.5)	1385 (54.5)	2433 (95.8)	2687 (105.8)	1120 (44.1)	2377 (93.6)
K20943	4491 (9900)	J95	4259 (157.7)	SRW	304.8 (12.0)	1219.2 (48.0)	1397 (55.0)	1651 (65.0)	3031 (119.3)	3284 (129.3)	1406 (55.4)	2982 (117.4)
K20943	4536 (10,000)	J95	4259 (157.7)	SRW	304.8 (12.0)	1219.2 (48.0)	1397 (55.0)	1651 (65.0)	3031 (119.3)	3284 (129.3)	1406 (55.4)	2982 (117.4)
K20953	4309 (9500)	J95	4017 (158.2)	SRW	304.8 (12.0)	1219.2 (48.0)	1323 (52.1)	1576 (62.0)	2863 (112.7)	3117 (122.7)	1326 (52.2)	2812 (110.7)
K20953	4491 (9900)	J95	4017 (158.2)	SRW	304.8 (12.0)	1219.2 (48.0)	1323 (52.1)	1576 (62.0)	2863 (112.7)	3117 (122.7)	1326 (52.2)	2812 (110.7)
K20953	4536 (10,000)	J95	4017 (158.2)	SRW	304.8 (12.0)	1219.2 (48.0)	1323 (52.1)	1576 (62.0)	2863 (112.7)	3117 (122.7)	1326 (52.2)	2812 (110.7)
K30743	4536 (10,000)	J95	3904 (153.7)	SRW	304.8 (12.0)	1219.2 (48.0)	1288 (50.7)	1542 (60.7)	2785 (109.6)	3039 (119.6)	1288 50.7)	2733 (107.6)
K30743	4899 (10,800)	J95	3904 (153.7)	SRW	304.8 (12.0)	1219.2 (48.0)	1074 (42.3)	1286 (50.6)	2971 (117.0)	3182 (125.3)	1171 (46.1)	2928 (115.3)
K30743	5216 (11,500)	J95	3904 (153.7)	SRW	304.8 (12.0)	1219.2 (48.0)	1074 (42.3)	1286 (50.6)	2971 (117.0)	3182 (125.3)	1171 (46.1)	2928 (115.3)
K30903	4536 (10,000)	J95	3395 (133.7)	SRW	304.8 (12.0)	1219.2 (48.0)	1131 (44.5)	1385 (54.5)	2433 (95.8)	2687 (105.8)	1120 (44.1)	2377 (93.6)

## CMVSS 105 and FMVSS 105 ALLOWABLE CENTER OF GRAVITY CHARTS

Model	GVWR kg (lb)	Brake System	Wheel- Base mm (in)	Rear Wheel	Incomplete, Pickup Box Removal, or Snow Plow Prep Package Vehicles							
					Coordinates of Allowable C/G Variation at CMVSS/FMVSS Unladen, Curb Weight + 181.4 kg (400 lb) or 226.8 kg (500 lb) as defined by CMVSS 105 and FMVSS 105 mm (in)						Fwd C/G Limit mm (in)	RRwd C/G Limit mm (in)
					H <sub>1</sub>	H <sub>2</sub>	A	B	C	D	E	F
K30903	4853 (10,700)	J95	3395 (133.7)	SRW	304.8 (12.0)	1219.2 (48.0)	943 (37.1)	1155 (45.5)	2593 (102.1)	2804 (110.4)	1019 (40.1)	2547 (100.3)
K30903	5171 (11,400)	J95	3395 (133.7)	SRW	304.8 (12.0)	1219.2 (48.0)	943 (37.1)	1155 (45.5)	2593 (102.1)	2804 (110.4)	1019 (40.1)	2547 (100.3)
K30903	5806 (12,800)	J96	3395 (133.7)	DRW	304.8 (12.0)	1219.2 (48.0)	943 (37.1)	1155 (45.5)	2593 (102.1)	2804 (110.4)	1019 (40.1)	2547 (100.3)
K30903	5897 (13,000)	J96	3395 (133.7)	DRW	304.8 (12.0)	1219.2 (48.0)	943 (37.1)	1155 (45.5)	2593 (102.1)	2804 (110.4)	1019 (40.1)	2547 (100.3)
K30943	4989 (11,000)	J95	4259 (157.7)	SRW	304.8 (12.0)	1219.2 (48.0)	1165 (45.9)	1377 (54.2)	3235 (127.4)	3446 (135.7)	1278 (50.3)	3195 (125.8)
K30943	5262 (11,600)	J95	4259 (157.7)	SRW	304.8 (12.0)	1219.2 (48.0)	1165 (45.9)	1377 (54.2)	3235 (127.4)	3446 (135.7)	1278 (50.3)	3195 (125.8)
K30943	5897 (13,000)	J96	4259 (157.7)	DRW	304.8 (12.0)	1219.2 (48.0)	1165 (45.9)	1377 (54.2)	3235 (127.4)	3446 (135.7)	1278 (50.3)	3195 (125.8)
K30953	4536 (10,000)	J95	4017 (158.2)	SRW	304.8 (12.0)	1219.2 (48.0)	1323 (52.1)	1576 (62.0)	2863 (112.7)	3117 (122.7)	1326 (52.2)	2812 (110.7)
K30953	4989 (11,000)	J95	4017 (158.2)	SRW	304.8 (12.0)	1219.2 (48.0)	1103 (43.4)	1315 (51.8)	3055 (120.3)	3266 (128.6)	1205 (47.4)	3013 (118.6)
K30953	5262 (11,600)	J95	4017 (158.2)	SRW	304.8 (12.0)	1219.2 (48.0)	1103 (43.4)	1315 (51.8)	3055 (120.3)	3266 (128.6)	1205 (47.4)	3013 (118.6)

## CMVSS 105 and FMVSS 105 ALLOWABLE CENTER OF GRAVITY CHARTS

Model	GVWR kg (lb)	Brake System	Wheel- Base mm (in)	Rear Wheel	Incomplete, Pickup Box Removal, or Snow Plow Prep Package Vehicles							
					Coordinates of Allowable C/G Variation at CMVSS/FMVSS Unladen, Curb Weight + 181.4 kg (400 lb) or 226.8 kg (500 lb) as defined by CMVSS 105 and FMVSS 105 mm (in)						Fwd C/G Limit mm (in)	RRwd C/G Limit mm (in)
					H <sub>1</sub>	H <sub>2</sub>	A	B	C	D	E	F
K30953	5897 (13,000)	J96	4017 (158.2)	DRW	304.8 (12.0)	1219.2 (48.0)	1103 (43.4)	1315 (51.8)	3055 (120.3)	3266 (128.6)	1205 (47.4)	3013 (118.6)
K31003	5987 (13,200)	J96	3493 (137.5)	DRW	304.8 (12.0)	1219.2 (48.0)	968 (38.1)	1180 (46.5)	2666 (105.0)	2877 (113.3)	1048 (41.3)	2619 (103.1)
K31043	5987 (13,200)	J96	4356 (171.5)	DRW	304.8 (12.0)	1219.2 (48.0)	1190 (46.9)	1402 (55.2)	3307 (130.2)	3518 (138.5)	1307 (51.5)	3267 (128.6)
K31403	5987 (13,200)	J96	4115 (162.0)	DRW	304.8 (12.0)	1219.2 (48.0)	1128 (44.4)	1340 (52.8)	3128 (123.1)	3339 (131.5)	1234 (48.6)	3086 (121.5)

SRW = Single Rear Wheel  
 DRW = Dual Rear Wheel  
 C/G = Center of Gravity  
 Brake Systems: Hydraulic Powered Boosters – J90, J95, J96

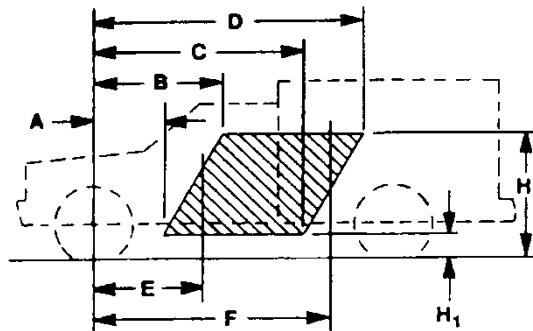

**C/G of vehicle in CMVSS or FMVSS unladen condition [Curb + 181.4 kg. (400 lb) or Curb + 226.8 kg. (500 lb) as defined by CMVSS 105 and FMVSS 105] must be inside shaded area – that is, the C/G must be within the trapezoid formed by the coordinates A, B, C, D, H<sub>1</sub>, & H<sub>2</sub>, plus the C/G must be to the rear of vertical line E and forward of vertical line F.**



## **CMVSS 108 and FMVSS 108 – LAMPS, REFLECTIVE DEVICES AND ASSOCIATED EQUIPMENT (Pickup and Utility)**

**TYPE 1** The following statement is applicable to Pickup and Utility types of incomplete vehicles contained in this document (unless otherwise noted on the cover).

This incomplete vehicle, when completed, will conform to CMVSS 108 and FMVSS 108 providing no alterations are made which affect the function, physical, chemical, or mechanical properties, environment, location or vital spatial clearances of the Owner Manual instructions and illumination components, assemblies or systems installed by General Motors.

The following lamp identification codes of the listed devices cannot be modified or changed. If lamp requirements are modified or changed, the following devices may have to be replaced:

Hazard Flasher – four #1157 lamps,  
two #194 lamps and two #168 lamps.  
Hazard Warning Signal Operating Unit –  
four #1157 lamps, two #194 lamps and two #168 lamps.

Turn Signal Flasher – two #1157 lamps,  
one #194 lamp and one #168 lamp.  
Turn Signal Operating Unit – two #1157 lamps,  
one #194 lamp and one #168 lamp.

## **CMVSS 108 and FMVSS 108 – LAMPS, REFLECTIVE DEVICES AND ASSOCIATED EQUIPMENT (Chassis Cab)**

**TYPE 1** The following statement is applicable to Chassis Cab types of incomplete vehicles contained in this document (unless otherwise noted on the cover).

This incomplete vehicle, when completed, will conform to CMVSS 108 and FMVSS 108 if it is completed with a body over 203 cm (80 in) in length, and providing the following conditions are met:

A. Each of these devices must be properly installed on the completed vehicle and meet all requirements of CMVSS 108 and FMVSS 108:

1. The following devices when provided, located and/or wired by General Motors meet the requirements of CMVSS 108 and FMVSS 108:

Back-up lamps  
Center high-mounted stop lamp  
Daytime running lamps controls and wiring (Canada)  
Front cab roof clearance and identification lamps  
Front side marker lamps  
Front side marker reflex reflectors  
Headlamp dimmer switch  
Headlamp highbeam indicator  
Headlamps and/or foglamps  
License plate lamp  
Park Lamps  
Owner Manual instructions

Rear reflex reflectors  
Rear side marker lamps  
Rear turn signal lamps  
Stop lamps  
Tail lamps  
Turn signal and Vehicle hazard warning indicator lamps  
Turn signal flasher  
Turn signal lamps  
Turn signal operating unit  
Vehicle hazard warning signal flasher  
Vehicle hazard warning signal operating unit

**(CMVSS 108 and FMVSS 108 – continued on next page)**

***(CMVSS 108 and FMVSS 108 – continued from previous page)***

2. No part of the completed vehicle shall be installed so as to prevent any of the devices listed on the previous page from meeting their required photometric output at the specified test points. If such interference exists, the applicable devices may have to be relocated or additional devices added to meet the requirements of CMVSS 108 and FMVSS 108. Any CMVSS 108 and FMVSS 108 part shall not be painted.
  3. The following additional devices must be installed on the rear body and meet all requirements of CMVSS 108 and FMVSS 108:

Front and rear clearance lamps	Rear side marker lamps
Front and rear identification lamps	Rear side marker reflex reflectors
  4. The following additional devices must be installed on the rear body and meet all the requirements of CMVSS 108 and FMVSS 108 if the overall vehicle length is 30 feet or greater:

Intermediate side marker lamps	Intermediate side reflex reflectors
--------------------------------	-------------------------------------
- B. No alterations are made which affect the function, physical, chemical, or mechanical properties, environment, location or vital spatial clearances of the components, assemblies or systems including but not limited to those listed in A, 1, above.
- C. Dealers, Intermediate or Final State Manufacturer's, after removing wooden shipping bumper, must relocate rear tail, stop and turn lights by switching the left hand and right hand brackets and lamp assembly so that the lights are mounted outboard of the shipping position. Two additional installation bolts are included in the Incomplete Vehicle Envelope.

***CMVSS 111 and FMVSS 111 – REARVIEW MIRRORS***

**TYPE 1 The following statement is applicable to all types of incomplete vehicles contained in this document, without shipped loose mirror or mirror delete options (unless otherwise noted on the cover).**

This incomplete vehicle will conform to CMVSS 111 and FMVSS 111 providing:

- A. No alterations or substitutions are made to the outside mirrors or inside mirrors furnished with the vehicle,
- B. The driver's seat location is not altered,
- C. The body width is not increased, and
- D. The body remains symmetrical about the vehicle centerline.

**TYPE 3 The following statement is applicable to all types of incomplete vehicles contained in this document, with shipped loose mirror or mirror delete options (unless otherwise noted on the cover).**

This vehicle will conform to FMVSS 111 providing no alterations or substitutions are made to the outside or inside mirrors furnished with the vehicle, the driver's seat location is not altered and the body width is not increased.

**CMVSS 135 and FMVSS 135 – LIGHT VEHICLE BRAKE SYSTEMS**  
**Applies to all types of Incomplete Vehicles Contained in this Document**  
**3500 kg (7,716 lb) GVWR or less**

**TYPE 2** The following statement is applicable to all types of Incomplete Vehicles contained in this document with a 3500 kg (7,716 lb) GVWR or less, (unless otherwise noted on the cover).

This incomplete vehicle when completed will conform to CMVSS 135 and FMVSS 135 provided it is completed in accordance with the following specific conditions by the (intermediate and) final stage manufacturer:

- A. Providing no alterations are made which affect the function, physical, chemical, or mechanical properties, environment, location or vital spatial clearances of the components, assemblies or systems, as manufactured by General Motors, including but not limited to those listed below (if equipped):

Anti-Lock Brake System	Hydraulic brake lines, fittings and routings
Brake assemblies and components (service/parking) - (i.e. power boosters, master cylinder, wheel cylinder, calipers, rotors, wheel speed sensor, wheel speed sensor wiring, brake lining etc.)	Hydraulic brake valves and components
Brake pedal, brake switch, parking brake hand lever or park brake switch and related mechanical components	Master cylinder-warning statement
Brake system electrical controls and logic	Owner Manual instructions
Gauges and warning devices, and statements	Parking brake actuator and related mechanical components
Hydraulic brake fluid and reservoirs	Power steering or vacuum lines and routing
	Power steering or vacuum pump
	Tires and Wheels
	Vacuum brake lines, fittings and routings
	Vehicle wiring harnesses
	Wheelbases

- B. GVWR, GAWR front and rear weight ratings as listed on the Incomplete Vehicle Label affixed to the front cover of this document must not be exceeded.
- C. The center of gravity of the total vehicle falls within the areas referenced on the "ALLOWABLE CENTER OF GRAVITY CHART" that follows. Instructions for determining the allowable center of gravity variation are listed below:

These charts detail the envelope of allowable center of gravity variation for completed vehicles. This is significant for the lightly loaded portion of CMVSS 135 and FMVSS 135, which is defined as curb plus 181.4 kg (400 lb) distributed in the driver-passenger area of the vehicle.

The lightly loaded center of gravity of complete vehicles needs to be restricted so it will meet CMVSS 135 and FMVSS 135 stopping distances. The laden center of gravity does not need to be specified as it is controlled within the CMVSS 135 and FMVSS 135 test procedure by specific instructions as to how ballast is to be placed (while height is not controlled, it is assumed that for test purposes it would be reasonable).

**CMVSS 135 and FMVSS 135 – LIGHT VEHICLE BRAKE SYSTEMS**  
**Applies to all types of Incomplete Vehicles Contained in this Document**  
**3500 kg (7,716 lb) GVWR or less**

For Body Builder's use, the center of gravity location can be approximated by the following formula:

$$d = \frac{[Wrc + Wrb + [(Hp)(Wp)/WB]] WB}{Wt}$$

$$h = \frac{[h1Wc + h2Wb + (h3)(Wp)]}{Wt}$$

- d = horizontal distance from front wheels to completed vehicle center of gravity mm (in)
- h = vertical distance from ground to completed vehicle center of gravity mm (in)
- Wrc = rear component of Chassis weight kg (lb)
- Wrb = rear component of body weight kg (lb)
- WB = vehicle wheelbase mm (in)
- Wt = total weight of chassis and body kg (lb) plus 181.4 kg (400 lb)
- h1 = center of gravity height from ground of the Bare Chassis = 711 mm (28 in)
- Wc = total weight of Chassis kg (lb)
- h2 = center of gravity height of body from ground mm (in)
- Wb = total weight of body kg (lb)
- Wp = 181.4 kg (400 lb) Amount from lightly loaded definition that is evenly distributed in driver-passenger area of vehicle.
- Hp = 1467 mm (57.76 in) Horizontal distance from front axle to center of gravity of 181.4 kg (400 lb) evenly distributed in driver-passenger area of vehicle.
- h3 = 948 mm (37.32 in) Vertical center of gravity height of 181.4 kg (400 lb) evenly distributed in driver-passenger area for vehicles with 3500 kg (7,716 lb) GVWR or less.

## CMVSS 135 and FMVSS 135 ALLOWABLE CENTER OF GRAVITY CHARTS

Model	GVWR kg (lb)	Brake System	Wheel- Base mm (in)	Rear Wheel	Incomplete, Pickup Box Removal, or Snow Plow Prep Package Vehicles							
					Coordinates of Allowable C/G Variation at CMVSS/FMVSS Unladen, Curb Weight + 181.4 kg (400 lb) mm (in)						Fwd C/G Limit mm (in)	RRwd C/G Limit mm (in)
					H <sub>1</sub>	H <sub>2</sub>	A	B	C	D	E	F
C10703	2903 (6400)	JF7	3022.6 (119.0)	SRW	305 (12.0)	1219 (48.0)	1020 (40.2)	1280 (50.4)	1690 (66.5)	2289 (90.1)	1020 (40.2)	2289 (90.1)
C10903	2903 (6400)	JF7	3378.2 (133.0)	SRW	305 (12.0)	1219 (48.0)	1130 (44.5)	1385 (54.5)	1967 (77.4)	2507 (59.3)	1130 (44.5)	2507 (59.3)
C10753	2903 (6400)	JF7	3644.9 (143.5)	SRW	305 (12.0)	1219 (48.0)	1213 (47.7)	1467 (57.8)	2109 (83.0)	2648 (104.2)	1213 (47.7)	2648 (104.2)
K10703	2903 (6400)	JF7	3022.6 (119.0)	SRW	305 (12.0)	1219 (48.0)	1020 (40.2)	1280 (50.4)	1690 (66.5)	2289 (90.1)	1020 (40.2)	2289 (90.1)
K10903	2903 (6400)	JF7	3378.2 (133.0)	SRW	305 (12.0)	1219 (48.0)	1130 (44.5)	1385 (54.5)	1967 (77.4)	2507 (59.3)	1130 (44.5)	2507 (59.3)
C10703	3084 (6800)	JF3	3022.6 (119.0)	SRW	305 (12.0)	1219 (48.0)	1020 (40.2)	1449 (57.0)	1905 (75.0)	2427 (95.5)	1119 (44.0)	2372 (93.4)
C10903	3175 (7000)	JF3	3378.2 (133.0)	SRW	305 (12.0)	1219 (48.0)	1130 (44.5)	1536 (60.5)	2106 (82.9)	2646 (104.2)	1250 (49.2)	2646 (104.2)
C10543	3084 (6800)	JF3	3644.9 (143.5)	SRW	305 (12.0)	1219 (48.0)	1213 (47.8)	1736 (68.3)	2393 (94.2)	2933 (115.5)	1277 (50.3)	2738 (107.8)
C10753	3084 (6800)	JF3	3644.9 (143.5)	SRW	305 (12.0)	1219 (48.0)	1213 (47.8)	1736 (68.3)	2393 (94.2)	2933 (115.5)	1277 (50.3)	2738 (107.8)
C10953	3130 (6900)	JF3	4000.5 (157.5)	SRW	305 (12.0)	1219 (48.0)	1323 (52.1)	1835 (72.2)	2387 (94.0)	3064 (120.6)	1323 (52.1)	3005 (118.3)
K10903	3084 (6800)	JF3	3378.2 (133.0)	SRW	305 (12.0)	1219 (48.0)	1130 (44.5)	1661 (65.4)	2076 (81.7)	2753 (108.4)	1181 (46.5)	2538 (99.9)
K10543	3175 (7000)	JF3	3644.9 (143.5)	SRW	305 (12.0)	1219 (48.0)	1213 (47.8)	1760 (69.3)	2169 (85.4)	2846 (112.0)	1261 (49.6)	2738 (107.8)
K10753	3175 (7000)	JF3	3644.9 (143.5)	SRW	305 (12.0)	1219 (48.0)	1213 (47.8)	1760 (69.3)	2169 (85.4)	2846 (112.0)	1261 (49.6)	2738 (107.8)

## CMVSS 135 and FMVSS 135 ALLOWABLE CENTER OF GRAVITY CHARTS

Model	GVWR kg (lb)	Brake System	Wheel- Base mm (in)	Rear Wheel	Incomplete, Pickup Box Removal, or Snow Plow Prep Package Vehicles							
					Coordinates of Allowable C/G Variation at CMVSS/FMVSS Unladen, Curb Weight + 181.4 kg (400 lb) mm (in)						Fwd C/G Limit mm (in)	RRwd C/G Limit mm (in)
					H <sub>1</sub>	H <sub>2</sub>	A	B	C	D	E	F
K10953	3175 (7000)	JF3	4000.5 (157.5)	SRW	305 (12.0)	1219 (48.0)	1323 (52.1)	1844 (72.6)	2358 (92.8)	3035 (119.5)	1383 (54.4)	3004 (118.3)
C10543	3084 (6800)	JD9	3644.9 (143.5)	SRW	305 (12.0)	1219 (48.0)	1213 (47.8)	1507 (59.3)	1879 (74.0)	2556 (100.6)	1213 (47.8)	2556 (100.6)
C10543	3220 (7100)	JD9	3644.9 (143.5)	SRW	305 (12.0)	1219 (48.0)	1213 (47.8)	1507 (59.3)	1814 (71.4)	2491 (98.1)	1213 (47.8)	2491 (98.1)
C10753	3084 (6800)	JD9	3644.9 (143.5)	SRW	305 (12.0)	1219 (48.0)	1213 (47.8)	1507 (59.3)	1879 (74.0)	2556 (100.6)	1213 (47.8)	2556 (100.6)
C10753	3175 (7000)	JD9	3644.9 (143.5)	SRW	305 (12.0)	1219 (48.0)	1213 (47.8)	1507 (59.3)	1835 (72.2)	2512 (98.9)	1213 (47.8)	2512 (98.9)
K10543	3175 (7000)	JD9	3644.9 (143.5)	SRW	305 (12.0)	1219 (48.0)	1213 (47.8)	1507 (59.3)	1835 (72.2)	2512 (98.9)	1213 (47.8)	2512 (98.9)
K10543	3311 (7300)	JD9	3644.9 (143.5)	SRW	305 (12.0)	1219 (48.0)	1213 (47.8)	1524 (60.0)	1774 (69.8)	2450 (96.4)	1213 (47.8)	2450 (96.4)
K10753	3175 (7000)	JD9	3644.9 (143.5)	SRW	305 (12.0)	1219 (48.0)	1213 (47.8)	1507 (59.3)	1835 (72.2)	2512 (98.9)	1213 (47.8)	2512 (98.9)
K10753	3266 (7200)	JD9	3644.9 (143.5)	SRW	305 (12.0)	1219 (48.0)	1213 (47.8)	1507 (59.3)	1794 (70.6)	2470 (97.2)	1213 (47.8)	2470 (97.2)

ABS = Antilock Braking System  
 Brake Systems: Vacuum Powered Boosters - JF3, JF7 and JD9.  
 C/G = Center of Gravity  
 DRW = Dual Rear Wheel  
 SRW = Single Rear Wheel  
 VSES = Vehicle Stability Enhancement System

## CMVSS 135 and FMVSS 135 ALLOWABLE CENTER OF GRAVITY CHARTS

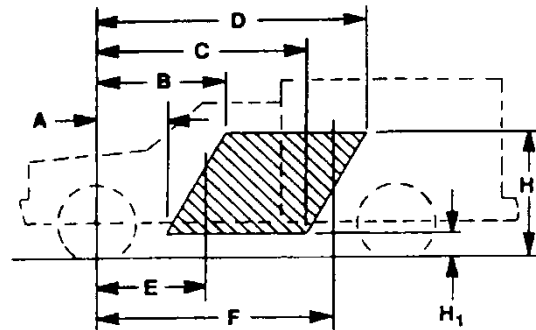

C/G of vehicle in CMVSS or FMVSS unladen condition [Curb + 181.4 kg. (400 lb)] must be inside shaded area – that is, the C/G must be within the trapezoid formed by the coordinates A, B, C, D, H1, & H2, plus the C/G must be to the rear of vertical line E and forward of vertical line F.

## **CMVSS 204 and FMVSS 204 – STEERING CONTROL REARWARD DISPLACEMENT**

**TYPE 1** The following statement is applicable to all types of incomplete vehicles contained in this document, 4536 kg (10,000 lb) GVWR or less and an unloaded vehicle weight of 2495 kg (5,500 lb) or less (unless otherwise noted on the cover).

This incomplete vehicle, when completed, will conform to CMVSS 204 and FMVSS 204 providing the “Maximum Unloaded Vehicle Weight” (found in Table A) is not exceeded, and no alterations are made which affect the function, physical, chemical, or mechanical properties, environment, location or vital spatial clearances of the components, assemblies or systems including but not limited to those listed below that would affect the steering control system displacement in a 48 k.p.h. (30 m.p.h.) fixed barrier impact:

Frame assembly and mounting system	Steering wheel, column, and shaft assembly
Front impact bar assembly and mounting system	Tires and wheels
Hood and hinge assemblies	Vehicle/body front-end sheet metal components
Powertrain and powertrain mounting system	Vehicle/body front-end structural components
Steering control system including related hardware	Vehicle/body roof structure and components

**TYPE 3** The following statement is applicable to any type of incomplete vehicle contained in this document, 4536 kg (10,000 lb) GVWR or less, with any bumper delete option (unless otherwise noted on the cover.)

Conformity with CMVSS 204 and FMVSS 204 cannot be determined based upon the components supplied on the incomplete vehicle, and General Motors makes no representation to conformity with the standard.

## **CMVSS 208 and FMVSS 208 – OCCUPANT CRASH PROTECTION**

**TYPE 1** The following statement is applicable to all types of vehicles contained in this document (unless otherwise noted on the cover) having an unloaded vehicle weight of 2495 kg (5,500 lb) or less and a GVWR of 3856 kg (8,500 lb) or less (except for chassis cab models with KL6 or KL8 alternative fuels option), and built by General Motors with complete seats and seat belt assemblies. For vehicles GVWR of 3856 kg (8,500 lb) or less, the vehicle model number as shown on the label on the cover must be included on the final state manufacturer’s certification label.

- A. The front seating positions provided by General Motors will conform to the requirements of CMVSS 208 and FMVSS 208, providing the “Maximum Unloaded Vehicle Weight” (found in Table A) is not exceeded, and no alterations are made which affect the function, physical, chemical, or mechanical properties, environment, location or vital spatial clearances of the Owner Manual instructions and components, assemblies or systems including but not limited to those listed below:
1. The number, location or configuration of the designated seating positions; and
  2. The number, placement, installation or model number of the seat belt assemblies provided; and

**(CMVSS 208 and FMVSS 208 – continued on next page)**



*(CMVSS 208 and FMVSS 208 – continued from previous page)*

3. The instrument panel or its mounting, the steering column/shaft or its mounting, the knee bolster or its mounting, the steering wheel, horn pad, driver air bag module or its mounting and covering, passenger air bag module or its mounting or covering (if equipped), air bag crash sensors. Note: For the “Passenger Sensing System” (if equipped), modifying or putting a padded cover on the passenger seat can affect the performance of this system.
  4. Sensor Diagnostic Module (SDM), and all air bag system wiring. Do not relocate or move the SDM, or air bag crash sensors. Do not obstruct the path of air bag deployment. Do not mount any components that produce more than a 20 Gauss magnetic field as measured at the SDM. Speakers/magnets must be located at least 12.7 cm (5 in) from the SDM. You must disconnect the SDM before doing any welding on the vehicle, otherwise do not disconnect the SDM. **Caution: To help avoid Personal Injury due to unwanted air bag inflation, observe the following precautions!** Do not weld, solder, braze, hammer, machine, drill, heat, electrical splice, add onto, remove, relocate, test, paint, loosen or in any way alter air bag components or wiring or fuses. Carpet may be put over the SDM if an appropriate moisture barrier (such as rubber matted backing) is supplied. When performing any operation around air bag components or wiring including but not limited to any operations around the instrument panel, electrical wiring and fuse block, steering column/wheel, and the engine compartment you must disable the air bag system prior to the operation. If the vehicle is equipped with an SDM, you must disable the air bag system prior to installing intermediate or final stage manufacturer components. *Note: Striking or dropping a powered SDM may cause air bag deployment.* The air bag system must be enabled after operation completion. This must be verified before shipping the vehicle. Instructions for disabling and enabling the air bag system can be found in the GM service manual. **Note: All connectors that have wiring routed between the SDM and an air bag inflator module have yellow connectors.**
  5. If the sunshade is removed or altered, or if the intermediate or final stage manufacturer installs the sunshade, a new Inflatable Restraints System Caution label must be installed per CMVSS 208 and FMVSS 208 requirements. In order to be in compliance with CMVSS 208 and FMVSS 208 no other label shall be installed on the same side of the sunvisor as the Air Bag Caution label. The instrument panel temporary label must not be removed.
  6. The vehicle frame, front bumper system, front sheet metal or other front structure, roof structure, doors, floor pan, dash panel, cowl structure, driveline or contents of the engine compartment by any incomplete or final state manufacturer which would result in any difference from the modified vehicle’s deceleration if the modified vehicle were to be subjected to barrier impact tests conducted per CMVSS 208 and FMVSS 208.
- B. The rear seating positions by General Motors will conform to CMVSS 208 and FMVSS 208 providing no alterations are made to the number, location or configuration of the designated seats/seating positions or to the number, placement, installation or model number of the seat belt assemblies of this incomplete vehicle.
- C. Intermediate or final stage manufacturers are advised that mounting hardware ahead of the bumper/radiator, such as, but not limited to, plows, winches, brush guards, etc., may affect air bag sensing and resultant performance.

*(CMVSS 208 and FMVSS 208 – continued from previous page)*

**TYPE 1** The following statement is applicable to all types of vehicles contained in this document (unless otherwise noted on the cover) having either an unloaded vehicle weight greater than 2495 kg (5,500 lb) or a GVWR greater than 3856 kg (8,500 lb), and built by General Motors with complete seats and seat belt assemblies.

This incomplete vehicle, when completed, will conform to CMVSS 204 and FMVSS 204 providing no alterations are made which affect the function, physical, chemical, or mechanical properties, environment, location or vital spatial clearances of the components, assemblies or systems including but not limited to those listed below:

Owner Manual instructions  
Seat anchorages  
Seat assemblies

Seat belt anchorages  
Seat belt assemblies  
Seat belt warning system

For vehicles equipped with an optional Inflatable Restraint System, refer to additional information in the TYPE 1 statement immediately preceding.

**TYPE 3** The following statement is applicable to all types of incomplete vehicles contained in this document with respect to second- or third-row seats installed by the intermediate or final state manufacturer, and all chassis cab models with a GVWR of 3856 kg (8,500 lb) or less with options KL6 or KL8 alternative fuel (unless otherwise noted on the cover).

Conformity with CMVSS 208 and FMVSS 208 cannot be determined based upon the components supplied on the incomplete vehicle, and General Motors makes no representation to conformity with the standard.

## CMVSS 212 and FMVSS 212 – WINDSHIELD MOUNTING

**TYPE 1** The following statement is applicable to all types of incomplete vehicles contained in this document (unless otherwise noted on the cover) with a 4536 kg (10,000 lb) GVWR or less, when completed will conform to CMVSS 212 and FMVSS 212 if:

- A. No alterations are made which affect the function, physical, chemical, or mechanical properties, environment, location or vital spatial clearances of the components, assemblies or systems including but not limited to those listed below:

Air bag crash sensors	Seat belt anchorages
Air bag system including covers and module	Seat belt assemblies
Air bag system wiring harnesses, connectors, and fuses/relays	Sensor Diagnostic Module (SDM) and retainers/brackets
Dash panel and cowl assembly	Steering control system including related hardware
Doors and hinge assemblies	Steering wheel, column, and shaft assembly
Frame assembly and mounting system	Sun visor assemblies
Front impact bar assembly and mounting system	Vehicle/body front sheet metal – components/reinforcements
Hood and hinge assemblies	Vehicle/body front structural – components/reinforcements
Powertrain and powertrain mounting system	Vehicle/body roof structure and components
Seat anchorages	Windshield and windshield mounting system
Seat assemblies	Windshield frame/frame reinforcement

- B. The body and/or equipment installed must not exceed the completed vehicle's unloaded vehicle weight, maximum body weight, maximum center of gravity height, and maximum body height required values specified Table A.
- C. The clearance between the rear most part of the cab and the front of the body is not less than the minimum cab to body clearance specified in Table A.
- D. The minimum vertical clearance between the cab roof and any portion of the installed body or accessories that extends over the cab roof must not be less than 20 cm (8 in).
- E. During a 48 k.p.h. (30 m.p.h.) frontal barrier impact test, no component installed by any intermediate or final state manufacturer shall move forward from its permanently mounted position.

## CMVSS 219 and FMVSS 219 – WINDSHIELD ZONE INTRUSION

**TYPE 1** The following statement is applicable to all types of incomplete vehicles contained in this document a 4536 kg (10,000 lb) GVWR or less, but not applicable to walk-in vans, motor homes, tow-trucks, ambulance, or other emergency/rescue/medical vehicles equipped for wheelchairs (unless otherwise noted on the cover).

This incomplete vehicle, when completed, will conform to CMVSS 219 and FMVSS 219 providing:

A. No alterations are made which affect the function, physical, chemical, or mechanical properties, environment, location or vital spatial clearances of the components, assemblies or systems including but not limited to those listed below:

Antennae	Hood assembly
Body roof structure and components/reinforcements	Hood mounts
Body sheet metal components/reinforcements	Motor compartment structure and components
Body structural components/reinforcements	Windshield wiper
Dash panel and cowl structure	Windshield wiper motor

B. The vehicle does not exceed the unloaded vehicle weight specified in Table A.

C. During a 48 k.p.h. (30 m.p.h.) frontal barrier impact test:

1. No component installed by any intermediate or final stage manufacturer shall prevent the hood from folding differently than its designed folding pattern; and
2. No component installed by any intermediate or final stage manufacturer shall penetrate the windshield or protected zone.

**CMVSS 301 and FMVSS 301 – FUEL SYSTEM INTEGRITY**  
**Refer to Vehicle Types, GVWRs, and Applicable Statements that follow**

**TYPE 2** The following statement is applicable to all types of incomplete vehicles contained in this document 4536 kg (10,000 lb) GVWR or less with any Incomplete Option (unless otherwise noted on the cover).

This incomplete vehicle, when completed, will conform to CMVSS 301 and FMVSS 301 providing it is completed in accordance with the following specific conditions by the (intermediate and) final stage manufacturer:

- A. The following items when installed by General Motors will conform providing no alterations are made which affect the function, physical, chemical, or mechanical properties, environment, location or vital spatial clearances of the components, assemblies or systems, as manufactured by General Motors, including but not limited to those listed below:

Fuel filler door assembly	Fuel tank filler neck/pipe assembly
Fuel filter	Fuel tank filler neck/pipe fasteners
Fuel hose shields	Fuel tank filler neck/pipe hose clamp/clamp assembly
Fuel pipes and hose assemblies	Fuel tank filler neck/pipe housing assembly
Fuel system	Fuel tank filler neck/pipe plate
Fuel system attaching or protective structure	Fuel tank filler neck/pipe vent hose
Fuel system control module	Fuel tank filler neck/pipe vent hose clamp/strap
Fuel system fasteners and retainers	Fuel tank meter assembly
Fuel tank assembly	Fuel tank shields
Fuel tank cap assembly	Fuel vapor lines and canister assembly
Fuel tank filler neck hose	

- B. The (intermediate and) final stage manufacturer conforms to the following:
1. a box, platform, or other rear structural assembly must be installed on the back of the vehicle.
  2. the rear assembly structure must provide comparable stiffness to the pickup box sold as original equipment as part of the complete vehicle version of this product.
  3. the method of rear assembly structure mounting and mount properties (material and structural) are similar to the those used to attach the pickup box sold as original equipment as part of the complete vehicle version of this product.
  4. The dimension and mass as well as other restrictions (excluding the Maximum Frontal Area) found in MVSS 301 Table A, are not exceeded.

**CMVSS 301 and FMVSS 301 – FUEL SYSTEM INTEGRITY**  
**Refer to Vehicle Types, GVWRs, and Applicable Statements that follow**

- C. This incomplete vehicle, when completed, will conform to CMVSS 301 and FMVSS 301 Fuel System Integrity if:
1. No alterations are made to the fuel system and attaching or protective structure, the contents or arrangement of the engine compartment, the powertrain and driveline, the cab structure, the chassis structure, the bumper system, door structure, or tires and wheels.
  2. The dimension and mass as well as other restrictions (excluding the Maximum Frontal Area) found in MVSS 301 Table A, are not exceeded.
  3. The final stage manufacturer completes the fuel filler neck and fuel level sender installation(s) according to “Best Practices” or “Special Applications (if applicable)” sections within the **Body Builders Manual on the [www.gmupfitter.com](http://www.gmupfitter.com) website**. **If there are additional questions, contact the Upfitter Integration Hotline at 1-800-875-4742.**
  4. During all barrier impact tests:
    - a. No component installed by any intermediate or final stage manufacturer impinges or causes distortion to the fuel system with sufficient energy to puncture or separate the fuel system.
    - b. No vehicle modification by any intermediate or final stage manufacturer results in any portion of the vehicle impinging upon or causing distortion to the fuel system with sufficient energy to puncture or separate the fuel system. Care should be taken that the structural integrity of the vehicle is restored following any modification of the structure.
    - c. Any body installed by an intermediate or final stage manufacturer is mounted securely to absorb loads and prevent movement relative to the frame which could cause any fuel system component to be punctured, separated or otherwise damaged when tested to applicable procedures of CMVSS 301 or FMVSS 301.

## C/K Pickup Box Removal Program – TABLE A

<b>Models kg (lb) cm (in)</b>	<b>General Body Types</b>	<b>Maximum Body Center of Gravity Height cm (in)</b>	<b>Maximum Body Height cm (in)</b>	<b>Minimum Cab to Body Clearance cm (in)</b>	<b>Maximum Unloaded Vehicle (Curb) Weight kg (lb)</b>	<b>Maximum Body Weight kg (lb)</b>	<b>Maximum Frontal Area m<sup>2</sup> (ft<sup>2</sup>)</b>
<b>C10753</b> 2903 kg (6,400 lb) GVWR, 364.5 cm (143.5 in) WB, 106.34 cm (41.86 in) CA, Extended Cab	Low Service	35.6 cm (14.0 in) above the frame	Under 157.5 cm (62.0 in)	7.6 cm (3.0 in)	2606 kg (5,744 lb)	499 kg (1,100 lb)	Not currently offered incomplete
<b>C10753</b> 3084 kg (6,800 lb) GVWR, 364.5 cm (143.5 in) WB, 106.34 cm (41.86 in) CA, Extended Cab	Low Service	35.6 cm (14.0 in) above the frame	Under 157.5 cm (62.0 in)	7.6 cm (3.0 in)	2763 kg (6,089 lb)	499 kg (1,100 lb)	Not currently offered incomplete
<b>C10753</b> 3175 kg (7,000 lb) GVWR, 364.5 cm (143.5 in) WB, 106.34 cm (41.86 in) CA, Extended Cab	Low Service	35.6 cm (14.0 in) above the frame	Under 157.5 cm (62.0 in)	7.6 cm (3.0 in)	2727 kg (6,011 lb)	499 kg (1,100 lb)	Not currently offered incomplete
<b>C10903</b> 2903 kg (6,400 lb) GVWR, 337.8 cm (133.0 in) WB, 143.07 cm (56.32 in) CA, Regular Cab	Low Service	35.6 cm (14.0 in) above the frame	Under 157.5 cm (62.0 in)	7.6 cm (3.0 in)	2568 kg (5,660 lb)	499 kg (1,100 lb)	Not currently offered incomplete
<b>C10953</b> 3130 kg (6,900 lb) GVWR, 400.5 cm (157.5 in) WB, 143.07 cm (56.32 in) CA, Extended Cab	Low Service	35.6 cm (14.0 in) above the frame	Under 157.5 cm (62.0 in)	7.6 cm (3.0 in)	2809 kg (6,190 lb)	499 kg (1,100 lb)	Not currently offered incomplete
<b>C10703</b> 2903 kg (6,400 lb) GVWR, 302.3 cm (119.0 in) WB, 106.34 cm (41.86 in) CA Regular Cab	Low Service	35.6 cm (14.0 in) above the frame	Under 157.5 cm (62.0 in)	7.6 cm (3.0 in)	2505 kg (5,524 lb)	499 kg (1,100 lb)	Not currently offered incomplete
<b>K10753</b> 3175 kg (7,000 lb) GVWR, 364.5 cm (143.0 in) WB, 106.34 cm (41.86 in) CA Extended Cab	Low Service	35.6 cm (14.0 in) above the frame	Under 157.5 cm (62.0 in)	7.6 cm (3.0 in)	2870 kg (6,326 lb)	499 kg (1,100 lb)	Not currently offered incomplete

## C/K Pickup Box Removal Program – TABLE A (Continued)

<b>Models kg (lb) cm (in)</b>	<b>General Body Types</b>	<b>Maximum Body Center of Gravity Height cm (in)</b>	<b>Maximum Body Height cm (in)</b>	<b>Minimum Cab to Body Clearance cm (in)</b>	<b>Maximum Unloaded Vehicle (Curb) Weight kg (lb)</b>	<b>Maximum Body Weight kg (lb)</b>	<b>Maximum Frontal Area m<sup>2</sup> (ft<sup>2</sup>)</b>
<b>K10753</b> 3266 kg (7,200 lb) GVWR, 364.5 cm (143.5 in) WB, 106.34 cm (41.86 in) CA Extended Cab	Low Service	35.6 cm (14.0 in) above the frame	Under 157.5 cm (62.0 in)	7.6 cm (3.0 in)	2838 kg (6,254 lb)	499 kg (1,100 lb)	Not currently offered incomplete
<b>K10903</b> 2903 kg (6,400 lb) GVWR, 337.8 cm (133.0 in) WB, 143.07 cm (56.32 in) CA, Regular Cab	Low Service	35.6 cm (14.0 in) above the frame	Under 157.5 cm (62.0 in)	7.6 cm (3.0 in)	2606 kg (5,744 lb)	499 kg (1,100 lb)	Not currently offered incomplete
<b>K10903</b> 3084 kg (6,800 lb) GVWR, 337.8 cm (133.0 in) WB, 143.07 cm (56.32 in) CA, Regular Cab	Low Service	35.6 cm (14.0 in) above the frame	Under 157.5 cm (62.0 in)	7.6 cm (3.0 in)	2692 kg (5,934 lb)	499 kg (1,100 lb)	Not currently offered incomplete
<b>K10953</b> 3175 kg (7,000 lb) GVWR, 400.5 cm (157.5 in) WB, 143.07 cm (56.32 in) CA Extended Cab	Low Service	35.6 cm (14.0 in) above the frame	Under 157.5 cm (62.0 in)	7.6 cm (3.0 in)	2878 kg (6,344 lb)	499 kg (1,100 lb)	Not currently offered incomplete
<b>K10703</b> 2903 kg (6,400 lb) GVWR, 302.3 cm (119.0 in) WB, 106.34 cm (41.86 in) CA Regular Cab	Low Service	35.6 cm (14.0 in) above the frame	Under 157.5 cm (62.0 in)	7.6 cm (3.0 in)	2530 kg (5,579 lb)	499 kg (1,100 lb)	Not currently offered incomplete



**CMVSS 301 and FMVSS 301 – FUEL SYSTEM INTEGRITY**  
Refer to Vehicle Types, GVWRs, and Applicable Statements that follow

**TABLE A**

Models	GVWR kg (lb) (RPO)	Engine (RPO)	General Body Types	Maximum Body Center of Gravity Height cm (in)	Maximum Body Height cm (in)	Maximum Unloaded Vehicle Weight (Completed Vehicle Maximum Weight) kg (lb)	Maximum Body Weight kg (lb)	Maximum Frontal Area m <sup>2</sup> (ft <sup>2</sup> )
K20903 Reg. Cab	4,309 (9,500) (GEH)	6.0 L Gas (L96)	Low Service	35.6 (14.0) above the frame	Under 157.5 (62.0)	3,901 (8,600)	771 (1,700)	Not Applicable
K20903 Reg. Cab	4,309 (9,500) (GEH)	6.0 L Gas (L96)	High Service	51.6 (20.3) above the frame	157.5 (62.0) and over	3,901 (8,600)	816 (1,800)	Not Applicable
K20903 Reg. Cab	4,491 (9,900) (C4M)	6.6 L Diesel (LGH)	Low Service	35.6 (14.0) above the frame	Under 157.5 (62.0)	3,992 (8,800)	771 (1,700)	Not Applicable
K20903 Reg. Cab	4,491 (9,900) (C4M)	6.6 L Diesel (LGH)	High Service	51.6 (20.3) above the frame	157.5 (62.0) and over	3,992 (8,800)	1,179 (2,600)	Not Applicable
K20943 Crew Cab	4,491 (9,900) (C4M)	6.0 L Gas (L96)	Low Service	35.6 (14.0) above the frame	Under 157.5 (62.0)	3,992 (8,800)	771 (1,700)	Not Applicable
K20943 Crew Cab	4,491 (9,900) (C4M)	6.0 L Gas (L96)	High Service	51.6 (20.3) above the frame	157.5 (62.0) and over	3,992 (8,800)	816 (1,800)	Not Applicable
K20943 Crew Cab	4,536 (10,000) (C7A)	6.6 L Diesel (LGH)	Low Service	35.6 (14.0) above the frame	Under 157.5 (62.0)	3,992 (8,800)	771 (1,700)	Not Applicable

**CMVSS 301 and FMVSS 301 – FUEL SYSTEM INTEGRITY**  
Refer to Vehicle Types, GVWRs, and Applicable Statements that follow

**TABLE A**

Models	GVWR kg (lb) (RPO)	Engine (RPO)	General Body Types	Maximum Body Center of Gravity Height cm (in)	Maximum Body Height cm (in)	Maximum Unloaded Vehicle Weight (Completed Vehicle Maximum Weight) kg (lb)	Maximum Body Weight kg (lb)	Maximum Frontal Area m <sup>2</sup> (ft <sup>2</sup> )
K20943 Crew Cab	4,536 (10,000) (C7A)	6.6 L Diesel (LGH)	High Service	51.6 (20.3) above the frame	157.5 (62.0) and over	4,218 (9,300)	1,179 (2,600)	Not Applicable
K20953 Ext. Cab	4,309 (9,500) (GEH)	6.0 L Gas (L96)	Low Service	35.6 (14.0) above the frame	Under 157.5 (62.0)	3,992 (8,800)	771 (1,700)	Not Applicable
K20953 Ext. Cab	4,309 (9,500) (GEH)	6.0 L Gas (L96)	High Service	51.6 (20.3) above the frame	157.5 (62.0) and over	3,992 (8,800)	816 (1,800)	Not Applicable
K20953 Ext. Cab	4,536 (10,000) (C7A)	6.6 L Diesel (LGH)	Low Service	35.6 (14.0) above the frame	Under 157.5 (62.0)	3,992 (8,800)	771 (1,700)	Not Applicable
K20953 Ext. Cab	4,536 (10,000) (C7A)	6.6 L Diesel (LGH)	High Service	51.6 (20.3) above the frame	157.5 (62.0) and over	4,218 (9,300)	1,179 (2,600)	Not Applicable
C30943 Crew Cab	4,536 (10,000) (C7A)	6.0 L Gas (L96)	Low Service	35.6 (14.0) above the frame	Under 157.5 (62.0)	3,992 (8,800)	771 (1,700)	Not Applicable
C30943 Crew Cab	4,536 (10,000) (C7A)	6.0 L Gas (L96)	High Service	51.6 (20.3) above the frame	157.5 (62.0) and over	4,218 (9,300)	1,179 (2,600)	Not Applicable

**CMVSS 301 and FMVSS 301 – FUEL SYSTEM INTEGRITY**  
Refer to Vehicle Types, GVWRs, and Applicable Statements that follow

**TABLE A**

Models	GVWR kg (lb) (RPO)	Engine (RPO)	General Body Types	Maximum Body Center of Gravity Height cm (in)	Maximum Body Height cm (in)	Maximum Unloaded Vehicle Weight (Completed Vehicle Maximum Weight) kg (lb)	Maximum Body Weight kg (lb)	Maximum Frontal Area m <sup>2</sup> (ft <sup>2</sup> )
C30953 Ext. Cab	4,536 (10,000) (C7A)	6.0 L Gas (L96)	Low Service	35.6 (14.0) above the frame	Under 157.5 (62.0)	3,992 (8,800)	771 (1,700)	Not Applicable
C30953 Ext. Cab	4,536 (10,000) (C7A)	6.0 L Gas (L96)	High Service	51.6 (20.3) above the frame	157.5 (62.0) and over	4,218 (9,300)	1,179 (2,600)	Not Applicable
K30903 Reg. Cab	4,536 (10,000) (C7A)	6.0 L Gas (L96)	Low Service	35.6 (14.0) above the frame	Under 157.5 (62.0)	3,992 (8,800)	771 (1,700)	Not Applicable
K30903 Reg. Cab	4,536 (10,000) (C7A)	6.0 L Gas (L96)	High Service	51.6 (20.3) above the frame	157.5 (62.0) and over	4,218 (9,300)	1,179 (2,600)	Not Applicable
K30953 Ext. Cab	4,536 (10,000) (C7A)	6.0 L Gas (L96)	Low Service	35.6 (14.0) above the frame	Under 157.5 (62.0)	3,992 (8,800)	771 (1,700)	Not Applicable
K30953 Ext. Cab	4,536 (10,000) (C7A)	6.0 L Gas (L96)	High Service	51.6 (20.3) above the frame	157.5 (62.0) and over	4,218 (9,300)	1,179 (2,600)	Not Applicable

Notes:

- **Table A above applies to ONLY incomplete vehicles (RPO: &VXT) as manufactured by GM without pick-up boxes (RPO: &ZW9).**

## **CMVSS 301 and FMVSS 301 – FUEL SYSTEM INTEGRITY** **Refer to Vehicle Types, GVWRs, and Applicable Statements that follow**

### Notes:

- On page 2 within this document, before each vehicle illustration and after the word TYPE, is a list of types of vehicles into which the incomplete vehicle is designed to be manufactured. For the allowable vehicle TYPE(s), CMVSS 301 and FMVSS 301 only applies to vehicles with a 4536 kg (10,000 lb) GVWR or less. As a result, Table A does not include data for GVWRs exceeding 4536 kg (10,000 lb) GVWR.
- For all included models, the maximum cab to body clearance is 7.6 cm (3.0 in)
- CA (back of cab sheet metal to centerline of rear axle dimensions) are located within the Body Builder website, "General Arrangement" section, at [www.gmupfitter.com](http://www.gmupfitter.com) or contact the Upfitter Integration Hotline at 1-800-875-4742.
- \* The Maximum Frontal Area column applies to: PART II, U.S. EPA, CALIFORNIA, AND CANADIAN EXHAUST & EVAPORATIVE EMISSION REQUIREMENTS AND EPA FUEL ECONOMY REGULATIONS.
- The completed vehicle Maximum Unloaded Vehicle (Curb) Weight, and/or GVWR, should not be exceeded. If any of these restrictions are exceeded, re-certification by the final stage manufacturer will be required.
- The Maximum Body Weight equals the Maximum Unloaded Vehicle (curb) Weight minus the incomplete Cab & Chassis (curb) weight as manufactured by GM. The actual vehicle (curb) weight must be determined by weighing the vehicle with fuel and fluids filled, minus occupants and cargo. The Maximum Body Weight in Table A is based on the maximum possible incomplete Cab & Chassis (curb) weight as manufactured by GM. It may be permissible to exceed the Maximum Body Weight (as stated in Table A), provided the Maximum Unloaded Vehicle (curb) Weight (as stated in Table A) is not exceeded at final stage manufacturer completion.
- Also see the Vehicle Emission Control Information Label in the vehicle engine compartment for maximum completed vehicle curb weight, GVWR, and frontal area restrictions, if applicable.
- Note: WB refers to wheelbase; GVWR refers to Gross Vehicle Weight Rating.

## U.S. EPA, California, and Canadian Exhaust and Evaporative Emission Requirements and EPA Fuel Economy Regulations

Incomplete vehicles come in three major classifications: (1) Light Duty trucks (Light and Medium Duty in California) are certified by the primary manufacturer and the vehicle is labeled as being in compliance with emission and fuel economy requirements. (2) Heavy Duty Vehicles are required to have an engine certified by the engine manufacturer and the engine is labeled as being in compliance with emission requirements. (3) Light Duty Vehicles certified and labeled by the final stage manufacturer as being in compliance with emission and fuel economy requirements.

In addition, all gasoline-powered Federal/California Light Duty, Medium Duty and Heavy Duty Vehicles are required to have an approved fuel evaporative emission control system. Vehicles certified to Heavy Duty emission standards also require special evaporative emission labeling. In order to assure that Environmental Protection Agency (EPA), National Highway Traffic Safety Administration (NHTSA), California and Canada Emission Certification and/or Fuel Economy regulations are met, this vehicle must be completed in strict accordance with all instructions contained in this manual, especially the following instructions which relate to:

### **EMISSION RELATED COMPONENTS**

**TYPE 1** The following statement is applicable to all types of incomplete vehicles contained in this document (unless otherwise noted on the cover).

- A. This vehicle, when completed, will conform to U.S. EPA, CALIFORNIA, AND CANADIAN EXHAUST AND EVAPORATIVE EMISSION REQUIREMENTS AND EPA FUEL ECONOMY REGULATIONS providing no alterations are made which affect the function, physical, chemical, or mechanical properties, environment, location or vital spatial clearances of the components, assemblies or systems including but not limited to those listed below (if equipped), and installed by General Motors:

- Air Injection Reaction (AIR) System
- Axle
- Brake system
- Catalytic converter
- Components for AWD system (axle, propshaft, PTU)
- Coolant temperature sensor
- Crankcase emission control system
- Diesel fuel injection components/controls
- EGR system
- Engine assembly
- Engine electronics (ecm/pcm/vcm)
- Engine fan and drive
- Engine speed sensor
- Evaporative emission control system

- Exhaust emission control system
- Exhaust oxygen sensors
- Exhaust system
- Fuel injection system
- Fuel system
- Ignition system
- Intake system – Air Induction System (i.e. Air filter, Mass Air Flow (MAF) sensor, ducts)
- Oxygen sensor
- Positive Crankcase Ventilation System (PCV)
- Tires and wheels
- Transaxle/transmission assembly
- Turbocharger and associated equipment/controls

***(Continued on next page)***

- C. GVWR, GAWR front and rear weight ratings as listed on the Incomplete Vehicle Label affixed to the front cover of this document must not be exceeded.

NOTE: All Federal/California gasoline powered heavy duty vehicles (except those equipped with option NJ2 – Temporary Fuel Tank) will have an evaporative emission control system that is certified for a fuel tank capacity not to exceed the amount shown on the Vehicle Emission Control Information Label located on the fan shroud (C/K 1500/2500/3500). Intermediate or Final State Manufacturers wishing to add fuel tank capacity beyond the original equipment fuel tank capacity must contact California Air Resources Board and/or submit a written statement to the EPA Administrator that the Hydrocarbon Storage System has been upgraded according to the requirements of 40 CFR 86.088-35 (g) (2).

Vehicles equipped with option NJ2 – Temporary Fuel Tank do not have an evaporative emission control system.

## LABELS

**TYPE 1 The following statement is applicable to all types of incomplete vehicles contained in this document (unless otherwise noted on the cover).**

This incomplete vehicle, when completed, will conform to U.S EPA, CALIFORNIA, AND CANADIAN EXHAUST AND EVAPORATIVE EMISSION REQUIREMENTS AND EPA FUEL ECONOMY REGULATION labeling requirements providing no alterations are made which affect the function, physical, chemical, or mechanical properties, environment, location or vital spatial clearances of the Emission Control related Information Labels that are permanently affixed. The labels are required by government regulation and must not be obstructed from view or defaced so as to impair their visibility or legibility.

## Pickup Box Removal Fuel Fill System Modifications for Gasoline Vehicles

Certain guidelines must be adhered to in modifying the fuel fill and vent system to ensure that the completed product meets the manufacturer's requirements.

1. The fuel fill and vent system must be installed such that there is adequate clearance between the fuel fill vent system and the tires under all operating conditions. Body attachment brackets must also be located such that there is adequate clearance to all fuel system components, such as the fuel lines and the fuel level sending unit, under all operating conditions.
2. The fuel fill/vent pipe system available from the dealer includes a number of additional hose retaining beads. The pipe can be trimmed at the hose retaining beads to adjust for the various chassis lengths and body widths. The pipes must be trimmed only at locations where a hose retaining bead is present. A hose retaining bead must be present at each pipe to hose interface in a modified fuel fill and vent system. Pipe ends must be free of burrs which may be detrimental to satisfactory assembly and/or function.
3. A minimum of 8.0 inches of fill hose must be maintained between the filler neck and the fuel tank as measured in an outboard direction from the tank surface (at the fill hose nipple) to the outlet end of the filler neck.
4. Both the fill and the vent hoses must be routed (and supported, if needed) such that there are no sags or kinks. Excess hose length may be removed as required provided hose does not kink. As viewed from the filler neck, pipes and hoses must have a downward slope toward the tank. There should be a minimum of 4° of downward slope in the fill and vent pipes at any location.
5. The fuel fill and vent system should be restrained in the upfit vehicle. This is necessary to avoid chaffing, fretting, rubbing, etc. which may cause wear to the pipes or hoses.
6. Fuel fill hose clamps are to be tightened to 22 lb.-in. torque.
7. Fuel vent hose clamps are to be tightened to 16 lb.-in. torque.
8. Route the rear axle vent hose using the clips on the frame and the bracket on the fuel filler neck assembly.

## 2011 C/K HDCS Cab Chassis Service Body Attachment Provisions

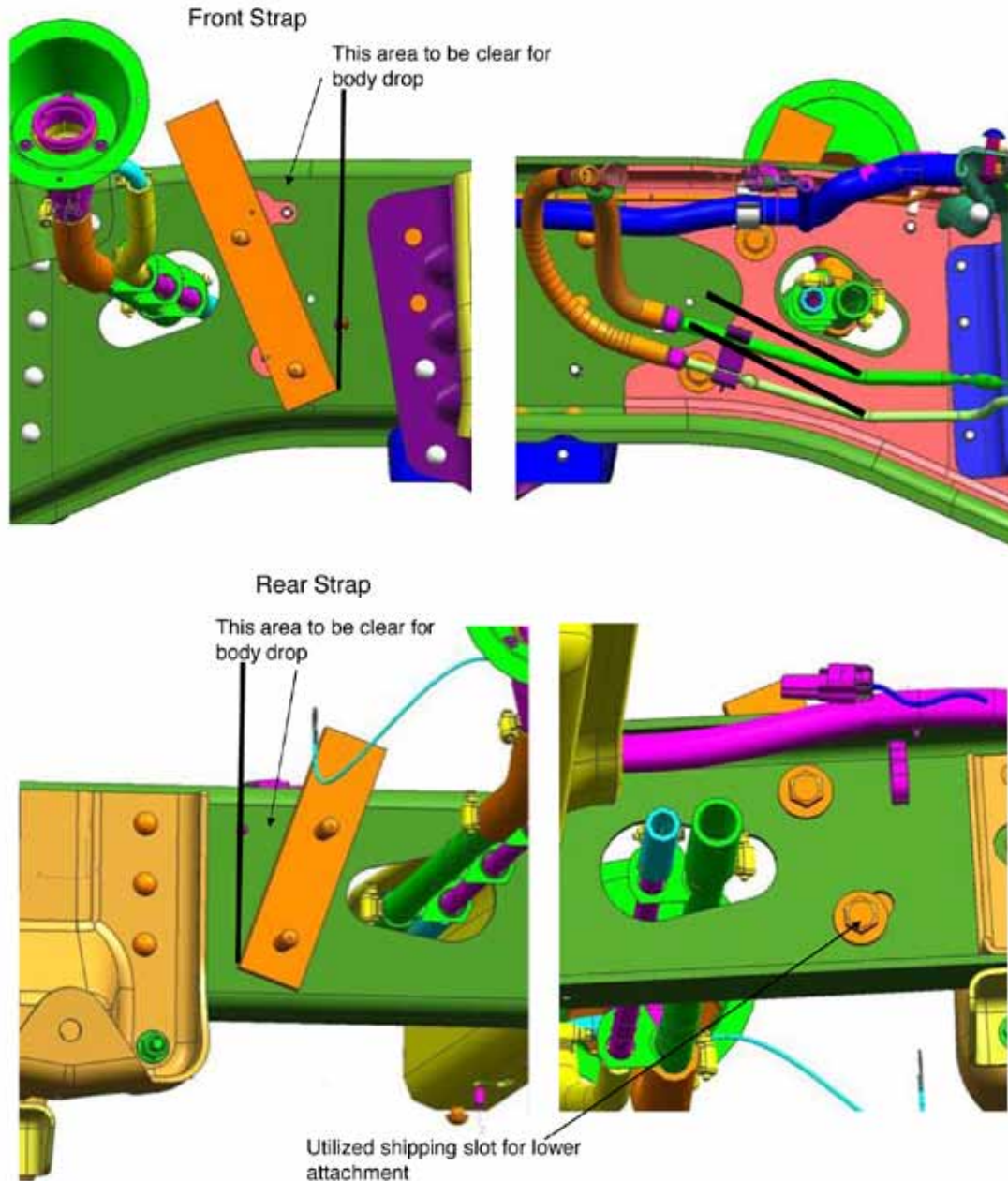



## 2011 C/K Fuel Filler Assembly Service Part #'s

Part No.	FNA Description	Series	Body Style	Options
20933028	PIPE ASM-TNK FIL	200903	034353	&FHO&ZW9
20945941	PIPE ASM-TNK FIL	200903	03	&FHX&ZW9
20955283	PIPE ASM-TNK FIL	310314	0343	&FHO&N2M/N2N
20945942	PIPE ASM-TNK FIL	310314	0343	&FHX&N2M/N2N
20945943	PIPE ASM-TNK FIL	310314	0343	&FHX&N2L
20955282	PIPE ASM-TNK FIL	310314	0343	&FHO&N2L

Option Key:

FHO – Gasoline (E5)  
FHS – E85  
FHX – Diesel B20  
ZW9 – Box Deleted  
N2N – Dual Tank CC  
N2L – Rear Tank Only CC  
N2M – Front Tank Only CC

Torque Recommendation:

Fuel Filler Hose 22 lb. in.  
Fuel Filler Vent Hose 16 lb. in.

## 2011 HDCS 'Gas Vapor Sensor' (shipped loose on ZW/9 Cab Chassis)

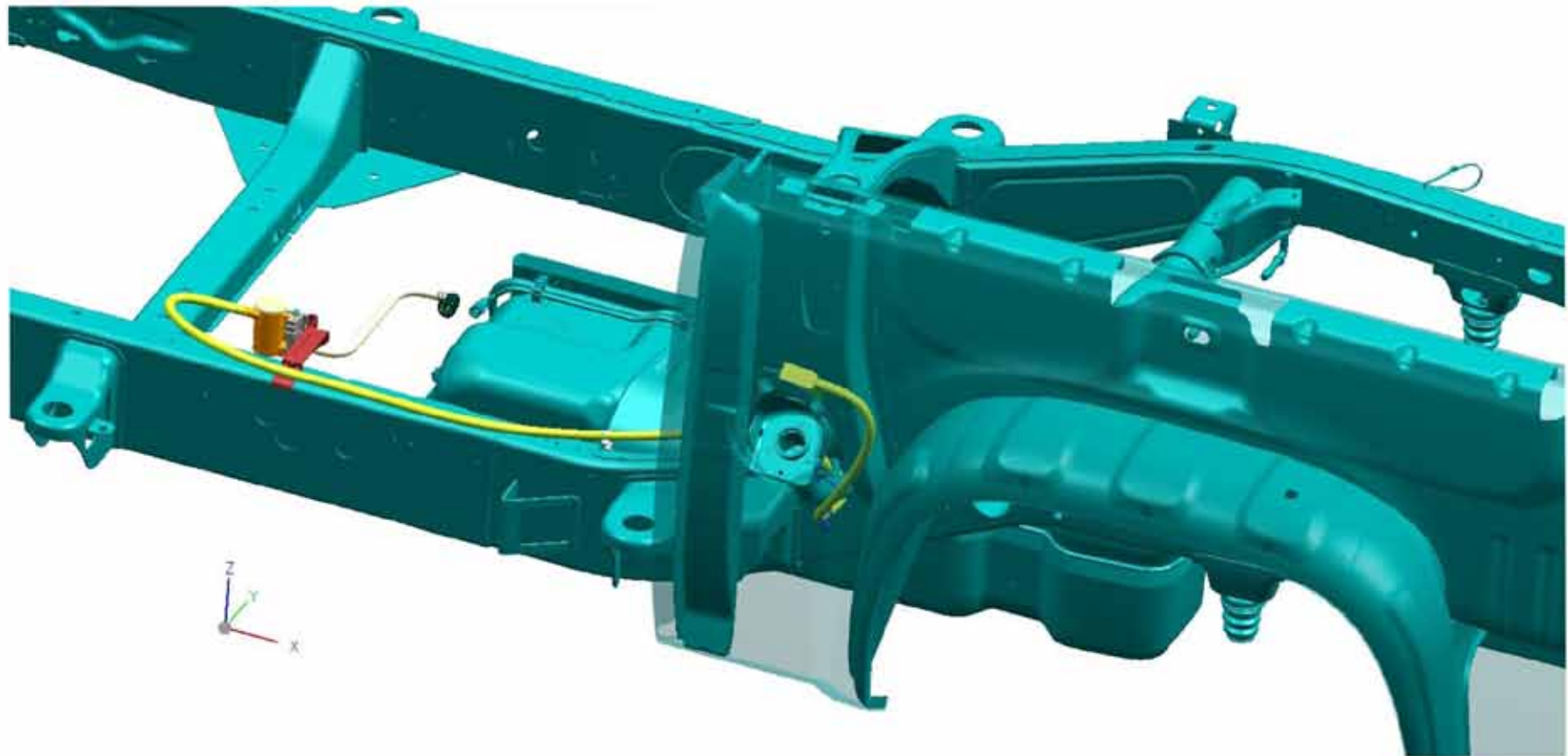

Note: Gas Models require Upfitter to permanently mount Vapor Pressure Sensor Unit in a sheltered environment. Sensor wire harness should also be secured properly. Harness and Sensor should be clear of moving and or heat generating chassis components.