

**DOCUMENT FOR INCOMPLETE VEHICLE,  
APPLICABLE TO THE 2017 MODEL YEAR CADILLAC  
XTS B05 – ARMORED VEHICLE, B9Q – FUNERAL COACH, V4U –  
LIMOUSINE, OR W30 – SHORT STRETCH LIVERY**

**General Motors, Renaissance Center  
P.O. Box 300  
Detroit, Michigan 48265-3000  
www.gm.com**

**DO NOT REMOVE**  
THIS DOCUMENT MUST REMAIN WITH THIS VEHICLE  
UNTIL IT IS CERTIFIED AS A COMPLETED VEHICLE

**PLACE LABEL HERE**

The Label affixed here includes the following information:

- the name of the incomplete vehicle manufacturer;
- the month and year the incomplete vehicle manufacturer performed its last manufacturing operation on the incomplete vehicle;
- the vehicle identification number (VIN);
- the Gross Vehicle Weight Rating (GVWR) expressed in kg (lb), intended for the vehicle when it is a completed vehicle;
  - The Gross Axle Weight Rating (GAWR) expressed in kg (lb), intended for each axle of the vehicle when it is a completed vehicle, listed in order from front to rear.

This document is furnished as required by the Canada Motor Vehicle Safety Act and United States (U.S.) Federal Motor Vehicle Safety Regulations (FMVSR) to aid intermediate and final stage manufacturers in their determination of conformity of the completed vehicle with applicable Canada Motor Vehicle Safety Standards (CMVSS) and U.S. Federal Motor Vehicle Safety Standards (FMVSS). Also included are instructions which must be followed in order to assure that Environmental Protection Agency (EPA) and California Air Resources Board (CARB) emission certification requirements, U.S. National Highway Traffic Safety Administration (NHTSA) Fuel Economy Regulations and Environmental Protection Agency (EPA) Greenhouse Gas Regulations are met.

This document is not a substitute for knowledge and understanding of the requirements of the Canada Motor Vehicle Safety Act, Federal Motor Vehicle Safety Regulations (FMVSR), or applicable Canada Motor Vehicle Safety Standards (CMVSS) and Federal Motor Vehicle Safety Standards (FMVSS). Intermediate and final stage manufacturers should be familiar with the Regulations and Standards referred to above to be aware of their specific responsibilities as they relate to the final destination and sale of each incomplete vehicle.

Any intermediate or final stage manufacturer making material alterations to this incomplete vehicle during the process of manufacturing the complete vehicle should be constantly vigilant to recognize all the effects, either direct or indirect, on other components, assemblies or systems caused by any alteration. No alteration should be made to the incomplete vehicle that directly or indirectly results in any component, assembly or system being in nonconformance with any applicable Canada Motor Vehicle Safety Standard or Federal Motor Vehicle Safety Standard or Emission Regulation or Fuel Economy/Greenhouse Gas Regulation.

The statements contained in this Incomplete Vehicle Document are accurate as of the date of manufacture of the Incomplete Vehicle and can be relied on by any intermediate and/or final stage manufacturer as a basis for certification.

# INTRODUCTION

This document contains information relative to conformance of this incomplete vehicle with the following:

- Part I - FEDERAL MOTOR VEHICLE SAFETY STANDARDS AND CANADA MOTOR VEHICLE SAFETY STANDARDS**
- Part II - U.S. ENVIRONMENTAL PROTECTION AGENCY, STATE OF CALIFORNIA, AND CANADIAN EMISSION REQUIREMENTS AND NHTSA FUEL ECONOMY REQUIREMENTS**

## PART I

This section contains a list of Canada Motor Vehicle Safety Standards (CMVSS), and Federal Motor Vehicle Safety Standards (FMVSS), followed by a section entitled "Statements Regarding Canada Motor Vehicle Safety Standards (CMVSS), and Federal Motor Vehicle Safety Standards (FMVSS)". In the latter section, an appropriate statement of applicability is made for each standard, and by vehicle type, as it relates to the incomplete vehicle.

The identifiers TYPE 1, TYPE 2 or TYPE 3 prefix the statements (of applicability) regarding Canada Motor Vehicle Safety Standards (CMVSS), and Federal Motor Vehicle Safety Standards (FMVSS). "Examples" of these statements follow:

- TYPE 1** A statement that the vehicle when completed will conform to the standard if no alterations are made in identified components of the incomplete vehicle. **EXAMPLE:** This vehicle when complete will conform to CMVSS 104 and FMVSS No. 104, Windshield Wiping and Washing Systems, if no alterations are made in the windshield wiper components.
- TYPE 2** A statement of specific conditions of final manufacture under which the manufacturer specifies that the completed vehicle will conform to the standard. **EXAMPLE:** This vehicle when completed will conform to CMVSS 121 and FMVSS 121, Air Brake Systems, if it does not exceed any of the gross axle weight ratings, if the center of gravity at GVWR is not higher than ## feet above the ground, and if no alterations are made to any brake system component.
- TYPE 3** A statement that conformity with the standard cannot be determined based upon the components supplied on the incomplete vehicle, and that the incomplete vehicle manufacturer makes no representation to conformity with the standard.

In accordance with the requirements of Canada Motor Vehicle Safety Regulations, and Federal Motor Vehicle Safety Regulations Part 568.4, the following information is included on the label affixed to the front cover of this document:

- the name of the incomplete vehicle manufacturer;
- the month and year the incomplete vehicle manufacturer performed its last manufacturing operation on the incomplete vehicle;
- the vehicle identification number (VIN);
- The Gross Vehicle Weight Rating (GVWR) expressed in kg (lb): The GVWR on the label on the cover of this document is for the incomplete vehicle itself. It is NOT the maximum GVWR of the completed vehicle and it should NOT be used on the final stage manufacturer's label. The maximum GVWR is shown in the GVWR TABLE that follows. The actual completed vehicle GVWR should be shown on the final stage manufacturer's certification label.
- The Gross Axle Weight Rating (GAWR) expressed in kg (lb): The GAWRs on the label on the cover of this document are for the incomplete vehicle. They are NOT the maximum GAWRs of the completed vehicle and they should NOT be used on the final stage manufacturer's certification label. The maximum GAWRs are shown in the GVWR/GAWR TABLE that follows. The actual completed vehicle GVWR/GAWRs should be shown on the final stage manufacturer's certification label.

In addition, the final stage manufacturer is responsible under Canada Motor Vehicle Safety Regulations, and Federal Motor Vehicle Safety Regulations and Part 567.5, to place the GVWR and the GAWR of each axle, on the Final Vehicle Certification Label. Required on the label is the "Gross Vehicle Weight Rating" or "GVWR" followed by the appropriate value in kilograms and (pounds), which shall not be less than the sum of the unloaded vehicle weight, rated cargo load, and

68 kg (150 lb) times the number of the vehicle's designated seating positions, if known. However, for school buses the minimum occupant weight allowance shall be 54.4 kg (120 lb) per passenger and 68 kg (150 lb) for the driver.

Unloaded Vehicle Weight means the weight of a vehicle with maximum capacity of all fluids necessary for operation of the vehicle, but without cargo, occupants or accessories that are ordinarily removed from the vehicle when they are not in use.

During the completion of this vehicle, GVWR and GAWR may be affected in various ways, including but not limited to the following:

- The installation of a body or equipment that exceeds the rated capacities of the Incomplete Vehicle.
- The addition of designated seating positions that exceed the rated capacities of the Incomplete Vehicle.
- Alterations or substitution of any components such as axles, springs, tires, wheels, frames, steering and brake systems that may affect the rated capacities of the Incomplete Vehicle.
- **For options B9Q – Funeral Coach, the incomplete vehicle is to be manufactured into a Truck. Type: Truck**
- **For options B05 – Armored Vehicle, V4U – Limousine, or W30 - Short Stretch Livery, the incomplete vehicle is to be manufactured into a Multipurpose Passenger Vehicle. Type: MPV**

### **GVWR/GAWR TABLE**

Option	GVWR		GAWR FRT		GAWR RR	
	lb	kg	lb	kg	lb	kg
W30	6,150	2789	3,198	1450	3,198	1450
B9Q	6,885	3123	3,580	1624	3,580	1624
V4U	6,885	3123	3,580	1624	3,580	1624
B05	6,885	3123	3,580	1624	3,580	1624

**If supplemental technical information is required to support this document, go to the GM Upfitter Integration website located at [www.gmupfitter.com](http://www.gmupfitter.com)**

### **PART I – CHART A**

LIST OF CANADA MOTOR VEHICLE SAFETY STANDARDS (CMVSS) AND  
FEDERAL MOTOR VEHICLE SAFETY STANDARDS (FMVSS), APPLICABLE  
TO THE CADILLAC XTS B05 – ARMORED VEHICLE, B9Q – FUNERAL COACH, V4U –  
LIMOUSINE, OR W30 – SHORT STRETCH LIVERY

**SEE STATEMENTS REGARDING CMVSS AND FMVSS ON PAGES THAT FOLLOW**

CMVSS NO.	FMVSS NO.	TITLE	B05 Armored Vehicle	B9Q Funeral Coach	V4U Limousine	W30 Short Stretch
1106	-	Exterior noise	1	1	1	1
ICES-002	-	Canada interference causing equipment standard	1	1	1	1
101	101	Controls and displays	1	1	1	1
102	102	Transmission shift position sequence, starter interlock and transmission braking effect	1	1	1	1
103	103	Windshield defrosting and defogging systems	1	1	1	1
104	104	Windshield wiping and washing systems	1	1	1	1
106	106	Brake hoses, hydraulic, air and vacuum	1	1	1	1
108	-	Daytime running lamps	1	1	1	1
108	108	Lamps, reflective devices and associated equipment	2	2,3	2	2

CMVSS NO.	FMVSS NO.	TITLE	B05 Armored Vehicle	B9Q Funeral Coach	V4U Limousine	W30 Short Stretch
110	110	Tire selection and rims for motor vehicles with a GVWR of 4536 kg (10,000 lb) or less	2	2	2	2
111	111	Rearview mirrors	3	3	3	3
113	113	Hood latch system	1	1	1	1
114	114	Theft protection and rollaway prevention	1	1	1	1
115	-	Vehicle identification number	1	1	1	1
116	116	Motor vehicle brake fluids	1	1	1	1
118	118	Power operated window, partition and roof panel systems	1	1	1	1
124	124	Accelerator control systems	1	1	1	1
126	126	Electronic stability control systems	2	2	2	2
135	135	Light vehicle brake systems	2	2	2	2
-	138	Tire pressure monitoring systems	2	2	2	2
201	201	Occupant protection in interior impact	3	3	3	3
202	202A	Head restraints	1	1,3	1	1
203	203	Impact protection for the driver from the steering control system	1	1	1	1
204	204	Steering control rearward displacement	1	1	1	1
205	205	Glazing materials	1	1	1	1
206	206	Door locks and door retention components	1	3	1	1
207	207	Seating systems	1,3	1,3	1,3	1,3
208	208	Occupant crash protection	2,3	2,3	2,3	2,3
209	209	Seat belt assemblies	1,3	1,3	1,3	1,3
210	210	Seat belt assembly anchorages	1,3	1,3	1,3	1,3
210.1	-	Tether anchorages for restraint systems	1,3	1,3	1,3	1,3
210.2	-	Lower universal anchorage systems for restraint systems and booster cushions	1,3	1,3	1,3	1,3
212	212	Windshield mounting	2	2	2	2
213.4	213	Built-in child restraint systems and built-in booster cushions	3	3	3	3
214	214	Side impact protection	2	2	2	2
216	216a	Roof crush resistance	3	3	3	3
219	219	Windshield zone intrusion	2	2	2	2
220	220	School bus rollover protection	3	3	3	3
	225	Child restraint anchorage system	1,3	1,3	1,3	1,3
301	301	Fuel system integrity	2	3	2	2
302	302	Flammability of interior materials	1,3	1,3	1,3	1,3
401	401	Internal Trunk Release	1	3	1	1
-	403	Platform Lift Systems	3	3	3	3
-	404	Platform Lift Systems Installations in Motor Vehicles	3	3	3	3

- TYPE 1, 2 or 3 numbers to the right-hand side of the table above designate the statement TYPE(S) associated with the CMVSS and/or FMVSS standards that follow.

# Statements Regarding Canada Motor Vehicle Safety Standards (CMVSS), and Federal Motor Vehicle Safety Standards (FMVSS)

## CMVSS 1106 – EXTERIOR NOISE

### Applies to all types of Incomplete Vehicles Contained in this Document

**TYPE 1** The following statement is applicable to all types of incomplete vehicles contained in this document (unless otherwise noted on the cover).

- A. This incomplete vehicle, when completed, will conform to the above standard providing no alterations are made which affect the function, physical, chemical, or mechanical properties, environment, location or vital spatial clearances of the components, assemblies or systems, as manufactured by General Motors, including but not limited to those listed below (if equipped):

Air Induction System (tuning elements)	Intake system (Air Induction System (i.e. Air filter, Mass Air flow (MAF) sensor, ducts))
Alternator	Power steering pump
Axles/halfshafts/propshaft	Powertrain control and logic
Components for AWD system (axle, propshaft, PTU)	Powertrain cooling fan and motor assemblies
Engine assembly	Radiator/condenser assembly to body seals
Exhaust System	Tires (including correct tire pressure)
Exterior noise generating devices	Transmission/Transaxle assembly
Exterior rearview mirror assemblies	Underbody shields including air deflector
Front of dash sound deadening material	Wheelhouse liners and shields
Hood assembly including sound deadening material and seals	

- B. Final compliance with CMVSS 1106 is the responsibility of the final stage manufacturer for any modifications, added material, components, or systems.

## INTERFERENCE CAUSING EQUIPMENT STANDARD (CANADA ONLY) – ICES-002

### Applies to all types of Incomplete Vehicles Contained in this Document

**TYPE 1** The following statement is applicable to all types of incomplete vehicles with spark ignition engines contained in this document (unless otherwise noted on the cover).

This incomplete vehicle, when completed, will conform to the performance requirements of the above standard provided no alterations are made which affect the function, physical, chemical, or mechanical properties, environment, location or vital spatial clearances of the components, assemblies or systems, as manufactured by General Motors, including but not limited to those listed below:

Ignition coil(s)	Spark plug wires
Ignition wires & plugs	VCM/PCM/ECM/TCM

The final stage manufacturer must provide a statement of compliance on the Final Stage Manufacturer's Compliance Label with the following bilingual information in order to comply with Industry Canada's Interference Causing Equipment Standard ICES/NMB-002:

ICES/NMB-002

## FMVSS 101 – CONTROLS AND DISPLAYS

### Applies to all types of Incomplete Vehicles Contained in this Document

## CMVSS 101– CONTROLS AND DISPLAYS

### Applies to all types of Incomplete Vehicles Contained in this Document with a GVWR of 4536 kg (10,000 lb) or less

**TYPE 1** The following statement is applicable to all types of Incomplete Vehicles contained in this document as noted above (unless otherwise noted on the cover).

This incomplete vehicle, when completed, will conform to CMVSS 101 and FMVSS 101 providing no alterations are made which affect the size, location, identification or illumination of the controls and displays or the location, travel and type of driver's seat, as manufactured by General Motors.

The following controls must be operable, and the following displays for the following functions and malfunctions shall be fitted in such a manner that they are identifiable, by the driver while the driver is seated in the driver's designated seating position with the driver's seat belt fastened around the driver in accordance with the manufacturer's instructions:

Hand operated controls (if equipped):

Automatic vehicle speed (cruise control)	Horn
Clearance lamps (switch)	Identification lamps (switch) Ignition (switch)
Clutch	Illumination intensity
Driver's sun visor	Manual choke
Engine start	Master lighting switch
Engine stop	Position, side marker, end-outline marker, identification or clearance lamps
Electric park brake switch	Rear window defogging and defrosting systems
Electronic stability control system "off"	Steering wheel
Hand throttle	Tail lamps
Hazard warning signal	Transaxle/transmission shifter (except transfer case)
Hazard warning switch	Turn signal
Headlamps	Windshield defogging and defrosting systems
Headlamp high or low beam switch	Windshield washer (washing system)
Heating and air conditioning fan	Windshield wiper (wiping system)
Heating and air conditioning system	

Foot operated controls (if equipped):

Accelerator	Tail lamp
Clutch	Windshield washer (washing system)
Headlamp high or low beam switch	Windshield wiper (wiping system)
Service brake pedal	

Displays (if equipped):

Air brake low pressure	Headlamp high beam
Air bag system readiness	Low brake air pressure telltale
Antilock brake system malfunction	Low brake fluid condition
Battery charging condition	Low tire pressure indication (see MVSS 138)
Brake lining wear-out condition	Odometer (Canada must be metric)
Brake system malfunction (Canada - ISO symbol)	Passenger air bag Status
Brake Pressure (system loss)	Parking brake applied
Electrical charge	Regenerative brake system malfunction
Electronic stability control system "off"	Seat belt (unfastened telltale)
Electronic stability control system malfunction	Speedometer (Canada must be metric)
Engine coolant temperature	Tire pressure monitoring system malfunction
Engine oil pressure	Transmission control position
Fuel level	Turn signal(s)
Gross loss of brake pressure condition	Variable brake proportioning system malfunction
Hazard warning signal	

If the intermediate or final stage manufacturer installs any of the above controls and displays, they must also meet the requirements of this standard.

**CMVSS 102 and FMVSS 102 – TRANSMISSION SHIFT POSITION SEQUENCE,  
STARTER INTERLOCK AND TRANSMISSION BRAKING EFFECT**  
**Applies to all types of Incomplete Vehicles Contained in this Document**

**TYPE 1** The following statement is applicable to all incomplete vehicle types contained in this document (unless otherwise noted on the cover).

This incomplete vehicle, when completed, will conform to CMVSS 102 and FMVSS 102 providing no alterations are made which affect the function, physical, chemical, or mechanical properties, environment, location or vital spatial clearances of the components, assemblies or systems, as manufactured by General Motors, including but not limited to those listed below (if equipped):

Automatic (AT) or Manual (MT) Transaxle/Transmission control and identification system, including but not limited to:

- |   |  |
|---|--|
| AT floor shift mechanism  | Automatic transmission/transaxle assembly              |
| AT gear ratios and final drive ratio                                | Brake - AT interlock controls                          |
| AT gear shift sequence and control logic (electrical or mechanical) | Engine starter interlock controls                      |
| AT neutral safety switch assembly and wire                          | MT clutch-starter interlock system                     |
| AT position indicator linkage and display                           | AT or MT shift position pattern (knob, plate or label) |
| AT steering column assembly   | Vehicle wiring harnesses                               |

**CMVSS 103 and FMVSS 103 – WINDSHIELD DEFROSTING AND DEFOGGING SYSTEMS**  
**Applies to all types of Incomplete Vehicles contained in this Document**

**TYPE 1** The following statement is applicable to all types of incomplete vehicles contained in this document (unless otherwise noted on the cover).

This incomplete vehicle, when completed, will conform to CMVSS 103 and FMVSS 103 providing no alterations are made which affect the function, physical, chemical, or mechanical properties, environment, location or vital spatial clearances of the components, assemblies or systems, as manufactured by General Motors, including but not limited to those listed below (if equipped):

Windshield defrosting and defogging systems, including but not limited to:

- |  |   |
|--|---|
| Chassis and instrument panel wiring harness assembly                           | Engine wiring harness   |
| Defroster air distributor assembly (manifold)                                  | Heater and air conditioning wiring harness                    |
| Defroster air duct assembly  | Heater and defroster assembly (including motor and blower)    |
| Defroster air hoses (distributor to nozzle)                                    | Heater and defroster control (electrical, mechanical, vacuum) |
| Defroster air to windshield outlet assembly (nozzle) (it affects blower speed) | Heater and radiator hoses/hose assemblies                     |
| Defroster outlet to heater assembly adapter                                    | Heater blower motor speed control                             |
| Engine control, software and calibration                                       | Side window defroster ducts                                   |
| Engine coolant pump  | Vacuum control hoses and electric actuators                   |
| Engine water outlet thermostat assembly  | Windshield assembly   |

**CMVSS 104 and FMVSS 104 - WINDSHIELD WIPING AND WASHING SYSTEMS**  
**Applies to all types of Incomplete Vehicles contained in this Document**

**TYPE 1** The following statement is applicable to all types of incomplete vehicles contained in this document (unless otherwise noted on the cover).

This incomplete vehicle, when completed, will conform to CMVSS 104 and FMVSS 104 providing no alterations are made which affect the function, physical, chemical, or mechanical properties, environment, location or vital spatial clearances of the components, assemblies or systems, as manufactured by General Motors, including but not limited to those listed below (if equipped):

Windshield wiping and washing systems, including but not limited to:

Vehicle wiring harness and electrical controls	Windshield washing system hoses
Washer reservoir cap	Windshield wiper arm assembly
Water reservoir filler assembly	Windshield wiper blade assembly
Windshield assembly	Windshield wiper linkage assembly
Windshield module attachments	Windshield wiper/washer control
Windshield washer fluid reservoir	Windshield wiper/washer motor/pump assembly
Windshield washer nozzle	

### **CMVSS 106 and FMVSS 106 – BRAKE HOSES, HYDRAULIC, AIR AND VACUUM Applies to all types of Incomplete Vehicles contained in this Document**

**TYPE 1** The following statement is applicable to all types of incomplete vehicles contained in this document (unless otherwise noted on the cover).

This incomplete vehicle, when completed, will conform to CMVSS 106 and FMVSS 106 providing no alterations are made which affect the function, physical, chemical, or mechanical properties, environment, location or vital spatial clearances of the components, assemblies or systems, as manufactured by General Motors, including but not limited to those listed below:

Hydraulic, Air, and Vacuum Brake Hoses and assemblies	Labeling requirements
---	-----------------------

### **CMVSS 108 – DAYTIME RUNNING LAMPS Applies to all types of Incomplete Vehicles contained in this Document**

**TYPE 1** The following statement is applicable to all types of incomplete vehicles contained in this document (unless otherwise noted on the cover).

This incomplete vehicle, when completed will conform to the Daytime Running Lamps (DRL) requirements of CMVSS 108 providing no alterations are made to the ignition switch, DRL system components or wiring, and any vehicle forward lighting as manufactured by General Motors.

### **CMVSS 108 and FMVSS 108 – LAMPS, REFLECTIVE DEVICES AND ASSOCIATED EQUIPMENT Applies to all types of Incomplete Vehicles contained in this Document**

**TYPE 2** The following statement is applicable to B05 – Armored Vehicle, B9Q – Funeral Coach front lamps, V4U – Limousine, or W30 – Short Stretch Livery types of incomplete vehicles contained in this document (unless otherwise noted on the cover).

This incomplete vehicle, when completed, will conform to CMVSS 108 and FMVSS 108 **IF** it is completed with a body less than 203.2 cm (80 in) in width, and a GVWR of 4536 kg (10,000 lb.) or less provided the following conditions are met:

Each of these devices must be properly installed on the completed vehicle and meet all requirements of CMVSS 108 and FMVSS 108:

A. The following devices when provided, located and/or wired by General Motors meet the requirements of CMVSS 108 and FMVSS 108:

Back-up lamps	Headlamp dimmer switch
Body control module (BCM)	Headlamp high beam indicator
Center high mounted stop lamp	License plate lamp
Daytime running lamps controls & wiring (Canada)	Owner Manual instructions
Fog lamps (if equipped)	Park lamps



Front side marker lamps  
Front side marker reflex reflectors  
Front turn signal lamps  
Hazard warning flasher  
Hazard warning signal operating unit  
Headlamps

Rear side marker lamps  
Rear side reflex reflectors  
Rear reflex reflectors  
Rear turn signal lamps  
Stop lamps  
Tail lamps  
Turn signal control

- B. No part of the completed vehicle shall be installed to prevent any of the devices listed above from meeting their required photometric output at the specified test points. If such interference exists, the applicable devices may have to be relocated or additional devices added to meet the requirements of CMVSS 108 and FMVSS 108. Any CMVSS 108 or FMVSS 108 part shall not be painted.
- C. No alterations are made which affect the function, physical, chemical, or mechanical properties, environment, location or vital spatial clearances of the components, assemblies or systems including but not limited to those listed in A above.

**TYPE 3 The following statement is applicable to the rear lamps on the B9Q - Funeral Coach incomplete vehicle type contained in this document (unless otherwise noted on the cover).**

For rear lamps, rear reflex reflectors, center high mount stop lamp, license plate mounting and turn signal lamp signal failure feature, conformity with CMVSS 108 and FMVSS 108 cannot be determined based upon the components supplied on the incomplete vehicle, and General Motors makes no representation to conformity with the standard.

**CMVSS 110 and FMVSS 110 – TIRE SELECTION AND RIMS FOR MOTOR VEHICLES  
WITH A GVWR OF 4536 kg (10,000 lb) OR LESS  
Applies to all types of Incomplete Vehicles contained in this Document**

**TYPE 2 The following statement is applicable to all types of incomplete vehicles contained in this document (unless otherwise noted on the cover).**

This incomplete vehicle, when completed, will conform to CMVSS 110 and FMVSS 110, providing:

- A. No alterations are made which affect the function, physical or mechanical properties, environment, location or vital spatial clearances of the components, assemblies or systems, as manufactured by General Motors, including but not limited to:

Owner Manual instructions  
Tires

Wheels

- B. GVWR, GAWR front and rear weight ratings as listed in the **Cadillac Master Coachbuilders (CMC) Guidelines Manual** and the Incomplete Vehicle document are not exceeded.
- C. The tire and wheel information shown at the end of this document must be transferred to the final stage manufacturer's Certification Label and the Tire Information Placard, providing no equipment or tire pressure changes are made, and the final stage manufacturer labels the vehicle in compliance with CMVSS 110 and FMVSS 110.

NOTE: Incomplete Vehicles referenced in this document may be shipped with reduced tire pressures for shipping purposes only.

**CMVSS 111 and FMVSS 111 – REARVIEW MIRRORS  
Applies to all types of Incomplete Vehicles contained in this Document**

**TYPE 3 The following statement is applicable to all types of incomplete vehicles contained in this document (unless otherwise noted on the cover).**

Conformity with CMVSS 111 and FMVSS 111 cannot be determined based upon the components supplied on the incomplete vehicle, and General Motors makes no representation to conformity with the standard.

**CMVSS 113 and FMVSS 113 – HOOD LATCH SYSTEM**  
**Applies to all types of Incomplete Vehicles contained in this Document**

**TYPE 1** The following statement is applicable to all types of incomplete vehicles contained in this document (unless otherwise noted on the cover).

This incomplete vehicle, when completed, will conform to CMVSS 113 and FMVSS 113 providing no alterations are made which affect the function, physical, chemical, or mechanical properties, environment, location or vital spatial clearances of the components, assemblies or systems, as manufactured by General Motors, including but not limited to those listed below:

Hood latch systems, which may include but are not limited to:

Hood latch (catch) assembly	Hood latch striker plate (hook) and reinforcements
Hood latch cable release system including controls	Hood latch support assembly
Hood latch pilot	

**CMVSS 114 and FMVSS 114 – THEFT PROTECTION AND ROLLAWAY PREVENTION**  
**Applies to all types of Incomplete Vehicles Contained in this Document**  
**4536 kg (10,000 lb) GVWR or less**

**TYPE 1** The following statement is applicable to all types of incomplete vehicles contained in this document, 4536 kg (10,000 lb) GVWR or less (unless otherwise noted on the cover).

This incomplete vehicle, when completed, will conform to CMVSS 114 and FMVSS 114 providing no alterations are made which affect the function, physical, chemical, or mechanical properties, environment, location or vital spatial clearances of the components, assemblies or systems, as manufactured by General Motors, including but not limited to those listed below:

Brake-transaxle/transmission interlock controls	Owner Manual Instructions
Electronic Immobilizer	Steering column lock assembly
Engine electronics (ECM/PCM/VCM)	Transaxle/Transmission assembly
Engine starter interlock controls	Transaxle/Transmission assembly neutral start switch and wiring
Ignition key	
Ignition key warning chime system	

**CMVSS 115 – VEHICLE IDENTIFICATION NUMBER**  
**Applies to all types of Incomplete Vehicles contained in this Document**

**TYPE 1** The following statement is applicable to all types of incomplete vehicles contained in this document (unless otherwise noted on the cover).

This incomplete vehicle, when completed, will conform to CMVSS 115 providing no alterations are made which affect the function, physical, chemical, or mechanical properties, environment, location or vital spatial clearances of the components, assemblies or systems, as manufactured by General Motors, including but not limited to those listed below:

The Vehicle Identification Number (VIN)	VIN plate fasteners
VIN label or plate	

**CMVSS 116 and FMVSS 116 – MOTOR VEHICLE BRAKE FLUIDS**  
**Applies to all types of Incomplete Vehicles contained in this Document**

**TYPE 1 The following statement is applicable to all types of incomplete vehicles contained in this document (unless otherwise noted on the cover).**

The hydraulic brake fluid in this incomplete vehicle, as manufactured by General Motors, will conform to CMVSS 116 and FMVSS 116 providing no alterations are made which affect the physical or chemical properties of the brake fluid.

**CMVSS 118 and FMVSS 118 – POWER OPERATED WINDOW, PARTITION  
AND ROOF PANEL SYSTEMS**  
**Applies to all types of Incomplete Vehicles Contained in this Document**  
**4536 kg (10,000 lb) GVWR or less**

**TYPE 1 The following statement is applicable to all types of incomplete vehicles contained in this document, 4536 (10,000 lb) GVWR or less (unless otherwise noted on the cover).**

This incomplete vehicle, if equipped by General Motors with power windows, when completed, will conform to CMVSS 118 and FMVSS 118 providing no alterations are made which affect the function, physical, chemical, or mechanical properties, environment, location or vital spatial clearances of the components, assemblies or systems, as manufactured by General Motors, including but not limited to those listed below (if equipped):

- |                                |   |
|--------------------------------|---|
| Power window electrical system | Power window operating system control logic |
| Power window operating system  | Window glazing material                     |

Final compliance with CMVSS 118 and FMVSS 118 is the responsibility of the final stage manufacturer for any modifications, or added material, components, or systems.

**CMVSS 124 and FMVSS 124 – ACCELERATOR CONTROL SYSTEMS**  
**Applies to all types of Incomplete Vehicles contained in this Document**

**TYPE 1 The following statement is applicable to all types of incomplete vehicles contained in this document (unless otherwise noted on the cover).**

This incomplete vehicle, when completed, will conform to CMVSS 124 and FMVSS 124 providing no alterations are made which affect the function, physical, chemical, or mechanical properties, environment, location or vital spatial clearances of the components, assemblies or systems, as manufactured by General Motors, including but not limited to those listed below:

Accelerator/throttle control systems, including but not limited to:

- |  |   |
|--|---|
| Attachment pin, hole or ball stud to fuel injection unit throttle lever    | Floor covering material must not be installed under pedal or within 25.4 mm (1 in) of side of pedal |
| Cable or rod, throttle or accelerator, and support bracket including seals | Lever, throttle or accelerator and supporting bracket   |
| Cruise control module, wiring and cable (if equipped)                      | Pedal-throttle or accelerator and attachments   |
| Electronic throttle control assembly and related wiring                    | Spring(s) - throttle or accelerator return  |

**CMVSS 126 and FMVSS 126 – ELECTRONIC STABILITY CONTROL SYSTEMS**  
**Applies to all types of Incomplete Vehicles Contained in this Document**  
**4536 kg (10,000 lb) GVWR or less**

**TYPE 2 The following statement is applicable to all types of incomplete vehicles contained in this document, 4536 kg (10,000 lb) GVWR or less (unless otherwise noted on the cover).**

This incomplete vehicle when completed will conform to CMVSS 126 and FMVSS 126 provided it is completed in accordance with the following specific conditions by the (intermediate and) final stage manufacturer:

- A. Providing no alterations are made which affect the function, physical, chemical, or mechanical properties, environment, location or vital spatial clearances of the components, assemblies or systems, as manufactured by General Motors, including but not limited to those listed below:

Anti-Lock Brake, Traction Control and Electronic Stability control system, including sensors and control module	Hydraulic brake valves and components
Brake assemblies and components (service/parking) - (i.e. power boosters, master cylinder, wheel cylinder, calipers, rotors, wheel speed sensor, wheel speed sensor wiring, brake lining etc.)	Master cylinder-warning statement
Brake pedal, brake switch, parking brake hand lever or park brake switch and related mechanical components	Owner Manual instructions
Brake system electrical controls and logic	Parking brake actuator and related mechanical components
Gauges and warning devices, and statements	Power steering or vacuum lines and routing
Hydraulic brake fluid and reservoirs	Power steering or vacuum pump
Hydraulic brake lines, fittings and routings	Tires and Wheels
	Stability control system, including control module, sensors and software calibrations
	Steering control system including related hardware
	Suspension components (i.e. bushings, control arms, shocks, springs, sway bars)
	Vacuum brake lines, fittings and routings
	Vehicle wiring harnesses

- B. The GVWR, GAWR front and rear weight ratings as listed on the Incomplete Vehicle Label affixed to the front cover of this document must not be exceeded.
- C. The Tire Pressures as listed on the Incomplete Vehicle Label affixed to the front cover of this document must be followed
- D. The Maximum Allowable Curb Weight kg (lb) (no passengers) of the completed vehicle cannot exceed the restrictions as shown in the table below:
- E. The maximum vertical Center of Gravity (CG) of the completed vehicle cannot exceed the Maximum “Z - Vertical CG Height Restriction Values” at the corresponding “Y - Lateral Center of Gravity Locations” as shown in the table below:

<b>Cadillac XTS, RGS - 235/55R18XL Continental ContiPro Contact Tire            CMVSS 126 and FMVSS 126 Compliance Certification            “X = Longitudinal, Y = Lateral and Z = Vertical Center of Gravity (CG) Restrictions”</b>							
Model Identification	Completed Vehicle Wheelbase in mm (in)	Maximum Allowable Completed Vehicle Curb Weight kg (lb) (no passengers)	Front/Rear Tire Pressures in kpa (psi)	@ X – allowable Longitudinal location (determined by weighing completed vehicle)	@ Y – Lateral CG Offset Location mm (in)		
					-50 (-1.97)	0 (0)	50 (1.97)
V4U	3294 (129.7) - 4615 (181.7)	2699 (5,950)	290 (42) / 290 (42)	% front axle weight restricted to range from 50 to 60%	675 (26.5)	700 (27.6)	675 (26.5)
B9Q	3751 (147.7) - 4107 (161.7)	2699 (5,950)	290 (42) / 290 (42)	% front axle weight restricted to range from 50 to 60%	675 (26.5)	700 (27.6)	675 (26.5)
W30	2964 (116.7) - 3015 (118.7)	2351 (5,185)	250 (36) / 250 (36)	% front axle weight restricted to range from 50 to 60%	625 (24.6)	650 (25.6)	625 (24.6)
B05	2837 (111.7), OR 2964 (116.7) - 3015 (118.7)	2699 (5,950)	290 (42) / 290 (42)	% front axle weight restricted to range from 50 to 60%	625 (24.6)	650 (25.6)	625 (24.6)
					<b>^^^ Maximum Z - Vertical CG Height Restriction Values ^^^</b>		

Note: Regarding the table above “The Maximum Z – Vertical CG Height Restriction Values” are reduced by 1mm (0.039 in.) for every 2mm (0.079 in.) of “ @ Y – Lateral CG Offset ... “ A V4U example follows: a Y – Lateral offset of +/- 10 mm (0.394 in.) equals a Z – Vertical restriction of 695 mm (27.36 in.)

- F. The lateral, longitudinal and vertical vehicle center of gravity locations can be approximated by following the three (3) formulas shown below:

### **Lateral Center of Gravity from Center Line of Vehicle Determination**

1. Position the vehicle such that all four wheels are resting in the center of the weight scales on a hard and flat horizontal surface as shown.
2. Record the weight at all four corners.

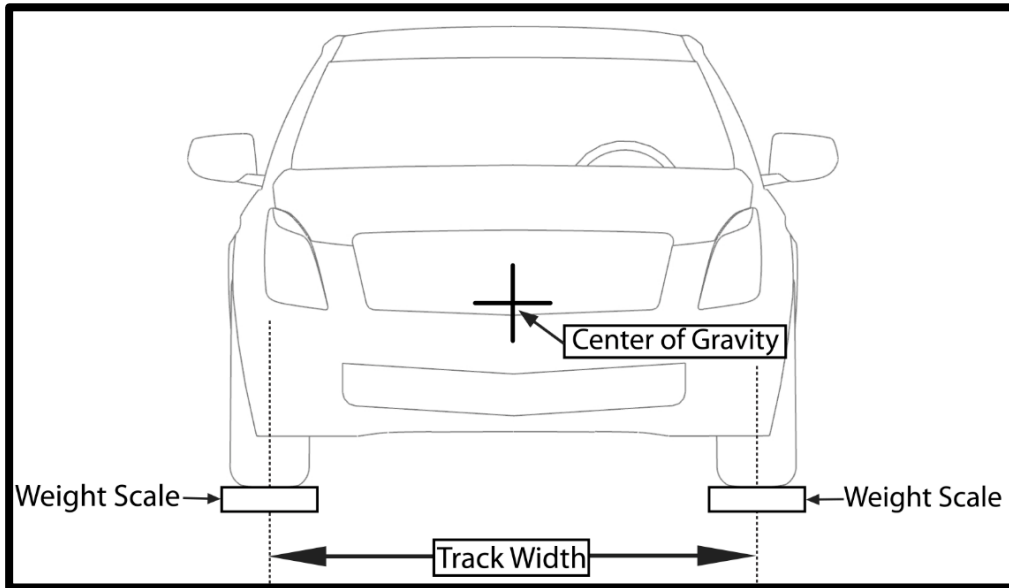

3. For all types of incomplete vehicles contained in this document with an average front track of 1587 mm (62.47 in), the **lateral** center of gravity location is determined by:

$$\frac{\text{Track Width} - \text{Track Width} \times (W_{RF} + W_{RR})}{2 W_T} = C_L \text{ cg}$$

Where:

- $W_T$  = Total vehicle weight =  $W_{LF} + W_{RF} + W_{LR} + W_{RR}$
- $W_{LR}$  = Weight at left rear wheel kg (lb)
- $W_{RR}$  = Weight at right rear wheel kg (lb)
- $W_{LF}$  = Weight at left front wheel kg (lb)
- $W_{RF}$  = Weight at right front wheel kg (lb)

### **Longitudinal Center of Gravity from Center Line of Vehicle Determination**

1. Position the vehicle such that all four wheels are resting in the center of the weight scales on a hard and flat horizontal surface as shown.
2. Record the weight at all four corners.

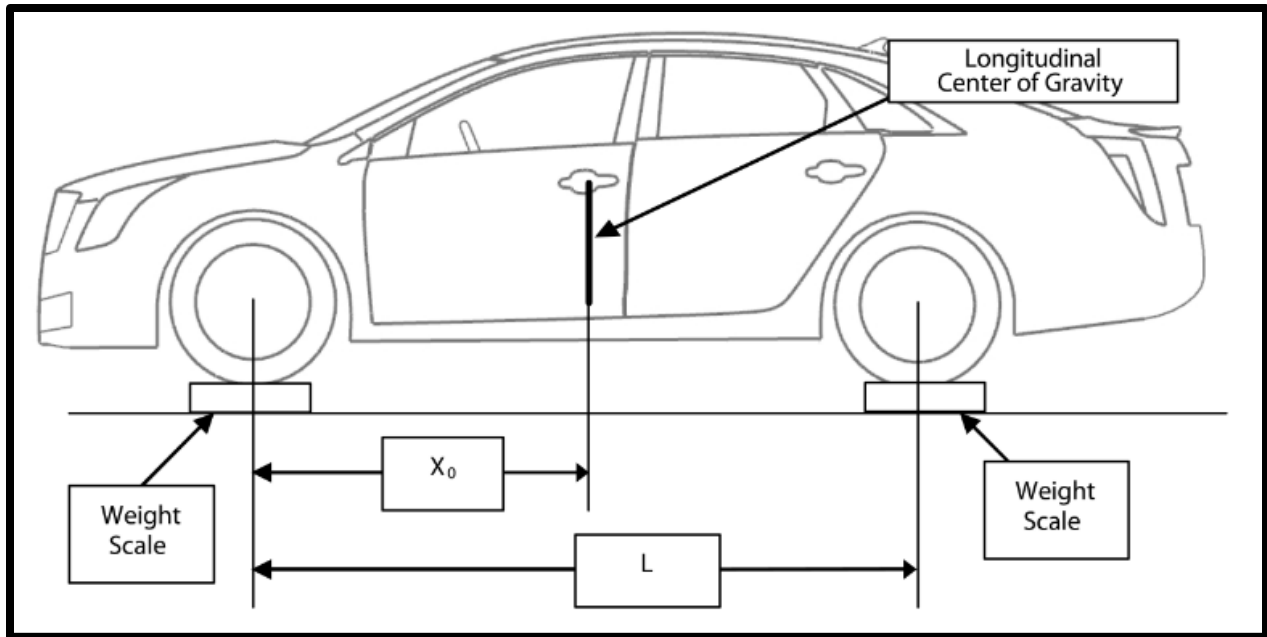

3. The **longitudinal** center of gravity location,  $X_0$ , is determined by:

$$X_0 = (L) \times (W_R/W_T)$$

Where:

- $X_0$  = Longitudinal center of gravity from front wheel center line mm (in)
- $L$  = Vehicle wheelbase mm (in)
- $W_R$  = Rear axle weight =  $W_{LR} + W_{RR}$
- $W_T$  = Total vehicle weight =  $W_{LF} + W_{RF} + W_{LR} + W_{RR}$
- $W_{LR}$  = Weight at left rear wheel kg (lb)
- $W_{RR}$  = Weight at right rear wheel kg (lb)
- $W_{LF}$  = Weight at left front wheel (kg (lb)
- $W_{RF}$  = Weight at right front wheel kg (lb)

### Vertical Center of Gravity Determination

1. Position the vehicle with the front tires raised to an incline of at least  $20^\circ$ , as shown below. An overhead or floor hoist is recommended to elevate the front of the vehicle. It must be able to support the weight of the vehicle and be structurally stable. Weight scales are needed under the rear tires only and must be horizontal so that true vertical weight is measured. The rear weight scales must be elevated approximately 381 mm (15 in) to provide sufficient ground clearance to the rear bumper and tail pipe.
2. Record the weight readings of the rear scales.

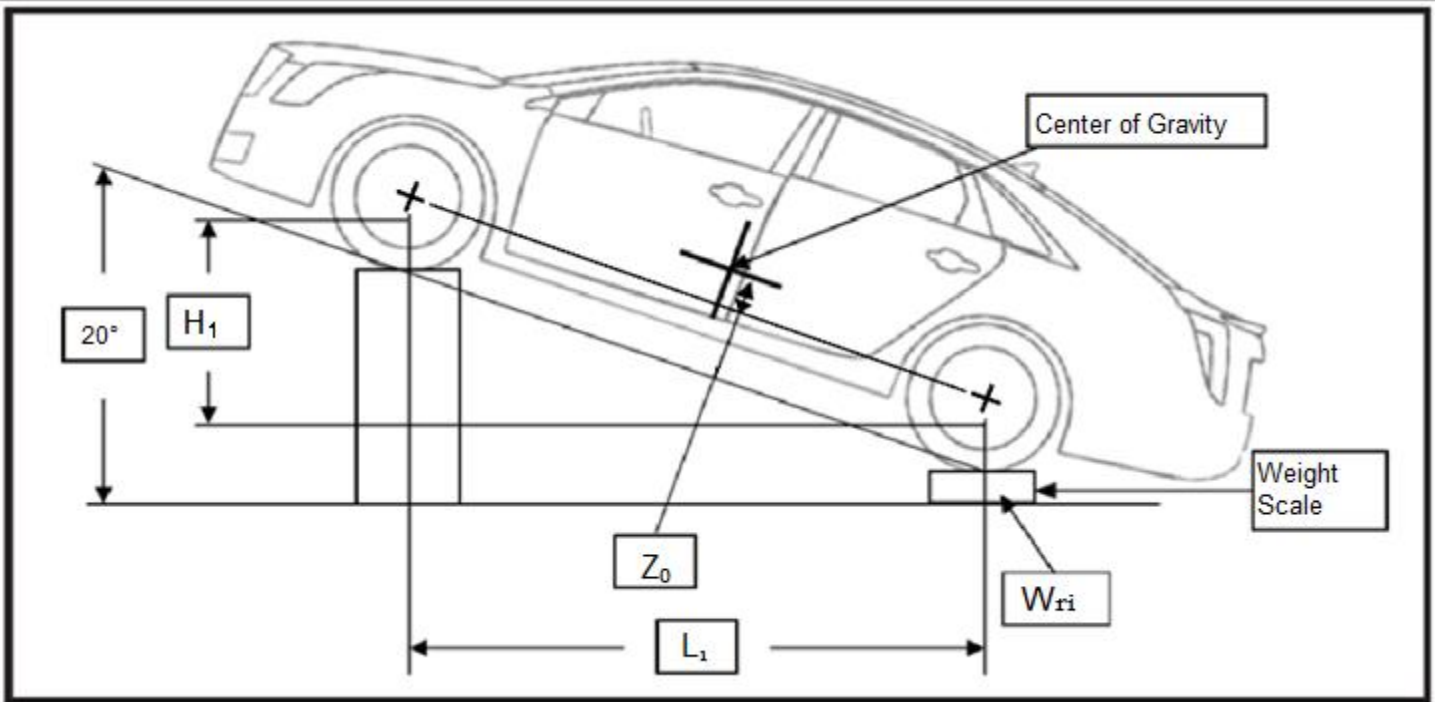

3. The vertical center of gravity location  $Z_0$  is determined by:

$$Z_0 = (L_1/H_1) \times (L \cdot W_{RI}/W_T - X_0)$$

Where:

- $L_1$  = Horizontal distance between front and rear wheels on incline mm (in)
- $H_1$  = Vertical distance between front and rear wheels on incline mm (in)
- $L$  = Vehicle wheelbase mm (in)
- $W_{RI}$  = Rear axle weight on incline =  $W_{LRI} + W_{RRI}$
- $W_{LRI}$  = Left rear weight on incline kg (lb)
- $W_{RRI}$  = Right rear weight on incline kg (lb)
- $W_T$  = Total vehicle weight (as previously determined)
- $X_0$  = Longitudinal center of gravity location (as previously determined)

**CMVSS 135 and FMVSS 135 – LIGHT VEHICLE BRAKE SYSTEMS**  
**Applies to all types of Incomplete Vehicles Contained in this Document**  
**with a 3500 kg (7,716 lb) GVWR or less**

**TYPE 2** The following statement is applicable to all types of incomplete vehicles contained in this document with a 3500 kg (7,716 lb) GVWR or less (unless otherwise noted on the cover).

This incomplete vehicle when completed will conform to CMVSS 135 and FMVSS 135 provided the intermediate or final stage manufacturer complete it in accordance with the following specific conditions:

A. Provided no alterations are made which affect the function, physical, chemical, or mechanical properties, environment, location or vital spatial clearances of the components, assemblies or systems including but not limited to those listed below:

Anti-Lock Brake System  
 Brake assemblies and components (service/parking) (i.e. power boosters, master cylinder, wheel cylinder, calipers, rotors, wheel speed sensor, wheel speed, sensor wiring, brake lining etc.)

Hydraulic brake lines, fittings and routings  
 Hydraulic brake valves and components  
 Master cylinder-warning statement  
 Owner Manual instructions

Brake pedal, brake switch, parking brake hand lever or park brake switch and related mechanical components  
 Brake system electrical controls and logic  
 Gauges and warning devices, and statements  
 Hydraulic brake fluid and reservoirs

Parking brake actuator and related mechanical components  
 Power steering or vacuum lines and routing  
 Power steering or vacuum pump  
 Tires and Wheels  
 Vacuum brake lines, fittings and routings  
 Vehicle wiring harnesses

- B. The percent front weight at GVWR and percent front weight in CMVSS 135 and FMVSS 135 lightly loaded condition are met as tabulated below per completed vehicle wheel base and vehicle type. NOTE: The wheelbase as shipped from General Motors is 2837 mm (111.7 in).

**CMVSS 135 and FMVSS 135 BRAKE TABLE**

Completed Vehicle Wheelbase		Vehicle Type	Percent of Front Weight at GVWR (percent)	Percent of Front Weight in Standard 135 Lightly Loaded Condition (percent)
mm	inches			
2837 OR 2964 - 3015	111.7 OR 116.7 - 118.7	B05	48.0 - 52.0	53.8 - 58.0
2964 - 3015	116.7 - 118.7	W30	48.0 - 52.0	53.8 - 58.0
3294 - 4615	129.7 - 181.7	V4U	48.0 - 52.0	53.8 - 58.0
3751 - 4107	147.7 - 161.7	B9Q	48.0 - 52.0	53.8 - 58.0

- C. The completed vehicle wheelbase does not exceed the maximum completed vehicle wheelbase as noted in the CMVSS 135 and FMVSS 135 BRAKE TABLE above.
- D. The GVWR, GAWR front and rear weight ratings as listed on the Incomplete Vehicle Label affixed to the front cover of this document must not be exceeded.
- E. The maximum vertical center of gravity cannot exceed the Z = Vertical Center of Gravity (CG) Restrictions at the 0 mm (in) Y – Lateral CG Offset Location shown in the “ ... CMVSS 126 and FMVSS 126 Compliance Certification ... Restrictions,” table.

**FMVSS 138 – TIRE PRESSURE MONITORING SYSTEM (If Equipped)**  
**Applies to all types of Incomplete Vehicles Contained in this Document**  
**with a 4536 kg (10,000 lb) GVWR or less**

**TYPE 2** The following statement is applicable to all types of incomplete vehicles contained in this document with a 4536 kg (10,000 lb) GVWR or less (unless otherwise noted on the cover).

This incomplete vehicle, when completed, will conform to FMVSS 138, providing the vehicle is equipped with a Tire Pressure Monitoring System (TPMS) installed by General Motors, and no alterations are made which affect the function, physical, chemical, or mechanical properties, environment, location or vital spatial clearances of the components, assemblies or systems including but not limited to those listed below:

Body control module  
 Instrument panel cluster  
 Owner Manual Instructions  
 Remote start coax antennae (if equipped)

Tires and Wheels  
 TPMS receiver module  
 TPMS sensors integral to the valve stems  
 Vehicle wiring harness

All incomplete vehicles shipped from the General Motors assembly plant may have tire pressures set for shipping purposes only. It is the responsibility of the final stage manufacturer to label the vehicle in compliance to FMVSS 138. In addition, it is the responsibility of the final stage manufacturer to ensure the TPMS system is calibrated to the values printed on the final stage manufacturer’s Tire Certification Label or Tire Information Label.



Wheelbase alteration, and/or addition of components may interfere with the TPMS radio frequency signal that may result in a malfunction warning displayed in the Driver Information Center (DIC). If this condition is observed, **go to the GM Upfitter Integration website located at [www.gmupfitter.com](http://www.gmupfitter.com)**

NOTE: The TPMS is not required to monitor the spare tire, either when it is stowed or when it is installed on the vehicle.

**CMVSS 201 and FMVSS 201 – OCCUPANT PROTECTION IN INTERIOR IMPACTS**  
**Applies to all types of Incomplete Vehicles Contained in this Document**  
**with a 4536 kg (10,000 lb) GVWR or less**

**TYPE 3** The following statement is applicable to all types of incomplete vehicles contained in this document, with a 4536 kg (10,000 lb) GVWR or less (unless otherwise noted on the cover).

Conformity with CMVSS 201 and FMVSS 201 cannot be determined based upon the components supplied on the incomplete vehicle, and General Motors makes no representation to conformity with the standard.

**CMVSS 202 and FMVSS 202A – HEAD RESTRAINTS**  
**Applies to all types of Incomplete Vehicles Contained in this Document**  
**4536 kg (10,000 lb) GVWR or less**

**TYPE 1** The following statement is applicable ALL seating positions in the B05 – Armored Vehicle, V4U – Limousine, or W30 – Short Stretch Livery types of incomplete vehicles contained in this document (unless otherwise noted on the cover).

This incomplete vehicle, when completed, will conform to CMVSS 202 and FMVSS 202A providing no alterations are made which affect the function, physical, chemical, or mechanical properties, environment, location or vital spatial clearances of the components, assemblies or systems, as manufactured by General Motors, including but not limited to those listed below

Seat assemblies equipped with head restraints                      Owner Manual instructions

**TYPE 1** The following statement is applicable to FRONT seating positions in the B9Q - Funeral Coach incomplete vehicle type contained in this document (unless otherwise noted on the cover).

This incomplete vehicle, when completed, will conform to CMVSS 202 and FMVSS 202A providing no alterations are made which affect the function, physical, chemical, or mechanical properties, environment, location or vital spatial clearances of the components, assemblies or systems, as manufactured by General Motors, including but not limited to those listed below

Seat assemblies including head restraints                      Owner Manual instructions

**TYPE 3** The following statement is applicable to REAR seating positions in the B9Q - Funeral Coach incomplete vehicle type contained in this document (unless otherwise noted on the cover).

Conformity with CMVSS 202 and FMVSS 202A cannot be determined based upon the components supplied on the incomplete vehicle, and General Motors makes no representation to conformity with the standard.

NOTE: If the intermediate or final stage manufacturer adds or modifies seats as manufactured by General Motors, they are also responsible to provide an addendum to the Owner Manual in order to meet CMVSS 202 and FMVSS 202A requirements.

**CMVSS 203 and FMVSS 203 – IMPACT PROTECTION FOR THE DRIVER FROM THE STEERING CONTROL SYSTEM**  
**Applies to all types of Incomplete Vehicles Contained in this Document**  
**with a 4536 kg (10,000 lb) GVWR or less**

**TYPE 1 The following statement is applicable to all types of incomplete vehicles contained in this document (unless otherwise noted on the cover).**

This incomplete vehicle, when completed, will conform to CMVSS 203 and FMVSS 203 provided the Maximum Completed Vehicle Curb Weight shown in the FUEL ECONOMY AND EMISSIONS TABLE located within section PART II found later in this document are not exceeded, and no alterations are made which affect the function, physical, chemical, or mechanical properties, environment, location or vital spatial clearances of the components, assemblies or systems including but not limited to those listed below:

Driver's seat assembly  
Instrument panel

Steering control system including related hardware  
Steering wheel, column, and shaft

**CMVSS 204 and FMVSS 204 – STEERING CONTROL REARWARD DISPLACEMENT**  
**Applies to all types of Incomplete Vehicles Contained in this Document**  
**with a 4536 kg (10,000 lb) GVWR or less and**  
**an unloaded vehicle weight of 2495 kg (5,500 lb) or less**

**TYPE 1 The following statement is applicable to all types of incomplete vehicles contained in this document (unless otherwise noted on the cover), with a 4536 kg (10,000 lb) GVWR or less and an unloaded vehicle weight of 2495 kg (5,500 lb) or less (unless otherwise noted on the cover).**

This incomplete vehicle, when completed, will conform to CMVSS 204 and FMVSS 204 provided the applicable maximum GVWR and GAWR's that appear on the Incomplete Vehicle Label affixed to the front cover of this document are not exceeded, and no alterations are made which affect the function, physical, chemical, or mechanical properties, environment, location or vital spatial clearances of the components, assemblies or systems including but not limited to those listed below that would affect the steering control system displacement in a 48 kph (30 mph) fixed barrier impact:

Front impact bar assembly and mounting system  
Hood and hinge assemblies  
Powertrain and powertrain mounting system  
Steering control system including related hardware

Steering wheel, column, and shaft assembly  
Tires and wheels  
Vehicle/body front-end sheet metal components  
Vehicle/body front-end structural components  
Vehicle/body roof structure and components

**CMVSS 205 and FMVSS 205 – GLAZING MATERIALS**  
**Applies to all types of Incomplete Vehicles contained in this Document**

**TYPE 1 The following statement is applicable to all types of incomplete vehicles contained in this document (unless otherwise noted on the cover).**

This incomplete vehicle, when completed, will conform to CMVSS 205 and FMVSS 205 providing no alterations are made which affect the function, physical, chemical, or mechanical properties, environment, location or vital spatial clearances of the components, assemblies or systems, as manufactured by General Motors, including but not limited to those listed below:

Glazing material  
Monogram

Visibility of the monogram  
Windshield shade banding

Final compliance with CMVSS 205 and FMVSS 205 is the responsibility of the final stage manufacturer for any modifications, or added material, parts, components, or systems.

**CMVSS 206 and FMVSS 206 – DOOR LOCKS AND DOOR RETENTION COMPONENTS**  
**Applies to all types of Incomplete Vehicles contained in this Document**  
**with a 4536 kg (10,000 lb) GVWR or less**

**TYPE 1 The following statement is applicable to B05 – Armored Vehicle, V4U – Limousine, or W30 – Short Stretch Livery types of incomplete vehicles contained in this document, with a 4536 kg (10,000 lb) GVWR or less (unless otherwise noted on the cover).**

This incomplete vehicle, when completed, will conform to CMVSS 206 and FMVSS 206 provided no alterations are made which affect the function, physical, chemical, or mechanical properties, environment, location or vital spatial clearances of the components, assemblies or systems including but not limited to those listed below:

Door and pillar systems, including but not limited to:

Body rear end upper and lower panel	Doors
Door hinges	Exterior door handles
Door latch strikers and striker plates	Inside lock control linkages
Door latches	Rear compartment latch and striker assembly
Door locks	Rear compartment lid assembly
Door pillars	Rear compartment lid hinge assembly
Door wedges	

Final compliance with CMVSS 206 and FMVSS 206 is the responsibility of the final stage manufacturer for any modifications, or added material, parts, components, or systems.

**TYPE 3 The following statement is applicable to the B9Q - Funeral Coach incomplete vehicle type contained in this document (unless otherwise noted on the cover).**

Conformity with CMVSS 206 and FMVSS 206 cannot be determined based upon the components supplied on the incomplete vehicle, and General Motors makes no representation to conformity with the standard.

### **CMVSS 207 and FMVSS 207 – SEATING SYSTEMS** **Applies to all types of Incomplete Vehicles Contained in this Document**

**TYPE 1 The following statement is applicable to all types of incomplete vehicles contained in this document (unless otherwise noted on the cover).**

This incomplete vehicle, when completed, will conform to CMVSS 207 and FMVSS 207 providing no alterations are made which affect the function, physical, chemical, or mechanical properties, environment, location or vital spatial clearances of the components, assemblies or systems, as manufactured by General Motors, including but not limited to those listed below:

Floor pan assemblies	Seat assembly
Folding seat or seat back latch assembly	Seat or seat back latch assembly
Seat adjuster assembly	Seat or seat back latch release control
Seat anchorage brackets, reinforcements, attachment hardware, etc.	Seat or seat back latch striker
	Seat riser

Final compliance with CMVSS 207 and FMVSS 207 is the responsibility of the final stage manufacturer for any modifications, or added material, parts, components, or systems.

**TYPE 3 The following statement is applicable to any type of incomplete vehicle contained in this document, with any seat delete option that is applicable to any seating position (unless otherwise noted on the cover).**

Conformity with CMVSS 207 and FMVSS 207 cannot be determined based upon the components supplied on the incomplete vehicle, and General Motors makes no representation to conformity with the standard.

### **CMVSS 208 and FMVSS 208 – OCCUPANT CRASH PROTECTION** **Applies to all types of Incomplete Vehicles Contained in this Document** **with a 3856 kg (8,500 lb) GVWR or less and** **an unloaded vehicle weight of 2495 kg (5,500 lb) or less**

**TYPE 2 The following statement is applicable to all seating positions in all types of incomplete vehicles contained in this document with the General Motors allowable unloaded vehicle weight of 2495 kg (5,500 lb) or less and a GVWR of 3856kg (8,500 lb) or less (unless otherwise noted on the cover).**

- A. The front seating positions provided by General Motors will conform to the requirements of CMVSS 208 and FMVSS 208, providing the “Vehicle Test Weight” specified in the table that appears in section Part II toward the end of this document is not exceeded, and no alterations are made which affect the function, physical, chemical, or mechanical properties, environment, location or vital spatial clearances of the components, assemblies or systems including but not limited to those listed below:
1. The number, location or configuration of the designated seating positions.
  2. The number, placement, installation or model number of the seat belt assemblies provided.
  3. The owner manual instructions, the instrument panel or its mounting, the steering column/shaft or its mounting, the knee bag or its mounting, the steering wheel, horn pad, driver air bag module or its mounting and covering, passenger airbag module or its mounting or covering (if equipped), air bag crash sensors.  
**Note: For the “Passenger Sensing System” (if equipped), modifying or putting a padded cover on the passenger seat can affect the performance of this system.**
  4. Sensor Diagnostic Module (SDM) and all air bag system wiring. Do not relocate or move the SDM, or airbag crash sensors. Do not obstruct the path of air bag deployment. Do not mount any components that produce more than a 20 Gauss magnetic field as measured at the SDM. Speakers/*magnets* must be located at least 12.7 cm (5 in) from the SDM. You must disconnect the SDM before doing any welding on the vehicle, otherwise do not disconnect the SDM. **Caution: To help avoid Personal Injury Due to unwanted air bag inflation, observe the following precautions!** Do not weld, solder, braze, hammer, machine, drill, heat, electrical splice, add onto, remove, relocate, test, paint, loosen or in any way alter air bag components or wiring or fuses. Carpet may be put over the SDM if an appropriate moisture barrier (such as a rubber matted backing) is supplied. When performing any operation around air bag components or wiring, including but not limited to any operations around the instrument panel, electrical wiring and fuse block, steering column/wheel, and the engine compartment, you must disable the air bag system prior to the operation. If the vehicle is equipped with an SDM, you must disable the air bag system prior to installing intermediate or final stage manufacturer components. *Note: Striking or dropping a powered SDM may cause air bag deployment.* The air bag system must be enabled after operation completion. This must be verified before shipping the vehicle. Instructions for disabling and enabling the air bag system can be found in the GM service manual. **Note: All connectors that have wiring routed between the SDM and an air bag inflator module have yellow connectors.**
  5. If the sun visor is removed or altered, or if the intermediate or final stage manufacturer installs the sun visor, a new Inflatable Restraints System Caution label must be installed per CMVSS 208 and FMVSS 208 requirements. In order to be in compliance with CMVSS 208 and FMVSS 208 no other label shall be installed on the same side of the sun visor as the Air Bag Caution label. The instrument panel temporary warning label must not be removed.
  6. The vehicle frame, front bumper system, front sheet metal or other front structure, roof structure, doors, floor pan, dash panel, cowl structure, driveline or contents of the engine compartment by any incomplete or final stage manufacturer which would result in any difference from the modified vehicle’s deceleration if the modified vehicle were to be subjected to barrier impact tests conducted per CMVSS 208 and FMVSS 208.
- B. The rear seating positions provided by General Motors will conform to CMVSS 208 and FMVSS 208 providing no alterations are made to the number, location or configuration of the designated seats/seating positions or to the number, placement, installation or model number of the seat belt assemblies of this incomplete vehicle.
1. Intermediate or final stage manufacturers are advised that mounting hardware ahead of the bumper/radiator, such as, but not limited to, plows, winches, brush guards, etc., may affect airbag sensing and resultant performance.

**TYPE 3 The following statement is applicable to all types of incomplete vehicles contained in this document with respect to any seats, seat belt assemblies or seat belt assembly anchorages installed by the intermediate or final stage manufacturer (unless otherwise noted on the cover).**

Conformity with CMVSS 208 and FMVSS 208 cannot be determined based upon the components supplied on the incomplete vehicle, and General Motors makes no representation to conformity with the standard.

**CMVSS 209 and FMVSS 209 – SEAT BELT ASSEMBLIES**  
**Applies to all types of Incomplete Vehicles Contained in this Document**

**TYPE 1** The following statement is applicable to all types of incomplete vehicles contained in this document (unless otherwise noted on the cover).

The seat belt assembly provided by General Motors when mounted to its original attachments locations at any designated seating position, will conform to CMVSS 209 and FMVSS 209 providing no alterations are made which affect the function, physical, chemical, or mechanical properties, environment, location or vital spatial clearances of the components, assemblies or systems, as manufactured by General Motors, including but not limited to those listed below:

Owner Manual instructions	Seat belt anchorages
Seat anchorages	Seat belt assemblies
Seat assemblies	

**TYPE 3** The following statement is applicable to all types of incomplete vehicles contained in this document with respect to any seats, seat belt assemblies or seat belt assembly anchorages installed by the intermediate or final stage manufacturer (unless otherwise noted on the cover).

Conformity with CMVSS 209 and FMVSS 209 cannot be determined based upon the components supplied on the incomplete vehicle, and General Motors makes no representation to conformity with the standard.

**CMVSS 210 and FMVSS 210 – SEAT BELT ASSEMBLY ANCHORAGES**  
**Applies to all types of Incomplete Vehicles Contained in this Document**

**TYPE 1** The following statement is applicable to all types of incomplete vehicles contained in this document (unless otherwise noted on the cover).

This incomplete vehicle, when completed, will conform to CMVSS 210 and FMVSS 210 providing no alterations are made which affect the function, physical, chemical, or mechanical properties, environment, location or vital spatial clearances of the components, assemblies or systems, as manufactured by General Motors, including but not limited to those listed below:

B, C, and D-pillar structures	Seat assemblies
Child restraint system including lower and top tether anchorages, seat brackets, plates and reinforcements	Seat belt assemblies
Floor pan assembly	Seat belt anchorage brackets, plates, and reinforcements
Owner Manual instructions	Seat belt routing
Roof structure	Seat position/adjustment capability

**TYPE 3** The following statement is applicable to all types of incomplete vehicles contained in this document with respect to any seats, seat belt assemblies or seat belt assembly anchorages installed by the intermediate or final stage manufacturer (unless otherwise noted on the cover).

Conformity with CMVSS 210 and FMVSS 210 cannot be determined based upon the components supplied on the incomplete vehicle, and General Motors makes no representation to conformity with the standard.

**CMVSS 210.1 – TETHER ANCHORAGES FOR RESTRAINT SYSTEMS**  
**Applies to all types of Incomplete Vehicles Contained in this Document to be completed as a Multipurpose Passenger Vehicle or Truck with a 3856 kg (8,500 lb) GVWR or less and an Unloaded Vehicle Weight of 2495 kg (5,500 lb) or less**

**TYPE 1** The following statement is applicable to all multipurpose passenger vehicle or truck types of incomplete vehicles contained in this document with a 3856 kg (8,500 lb) GVWR or less and an Unloaded Vehicle Weight of 2495 kg (5,500 lb) or less (unless otherwise noted on the cover).

This incomplete vehicle, when completed, will conform to CMVSS 210.1 provided the original equipment seats are not replaced, no seating positions are removed or added, and no alterations are made which affect the function, physical, chemical, or mechanical properties, environment, location or vital spatial clearances of the components, assemblies or systems, as manufactured by General Motors, including but not limited to those listed below:

Child restraint system including lower and top tether anchorages, seat brackets, plates and reinforcements	Owner Manual instructions
Access to lower anchorage system	Seat assemblies
Floor pan assembly	Seat belt assemblies
Labeling requirements	Seat belt anchorage brackets, plates, and reinforcements
Head restraints/head rests	Seat belt routing
	Seat position/adjustment capability

**TYPE 3** The following statement is applicable to all types of incomplete vehicles contained in this document with respect to any seats, seat belt assemblies or seat belt assembly anchorages installed by the intermediate or final stage manufacturer (unless otherwise noted on the cover).

Conformity with CMVSS 210.1 cannot be determined based upon the components supplied on the incomplete vehicle, and General Motors makes no representation to conformity with the standard.

**CMVSS 210.2 – LOWER UNIVERSAL ANCHORAGE SYSTEMS  
FOR RESTRAINT SYSTEMS AND BOOSTER CUSHIONS**  
**Applies to all types of Incomplete Vehicles Contained in this Document**  
**with a 3856 kg (8,500 lb) GVWR or less**  
**and an Unloaded Vehicle Weight of 2495 kg (5,500 lb) or less**

**TYPE 1** The following statement is applicable to all types of incomplete vehicles contained in this document (unless otherwise noted on the cover).

This incomplete vehicle, when completed, will conform to CMVSS 210.2 provided the original equipment seats are not replaced, no seating positions are removed or added, and no alterations are made which affect the function, physical, chemical, or mechanical properties, environment, location or vital spatial clearances of the components, assemblies or systems, as manufactured by General Motors, including but not limited to those listed below:

Child restraint system including lower and top tether anchorages, seat brackets, plates and reinforcements	Owner Manual instructions
Access to lower anchorage system	Seat assemblies
Floor pan assembly	Seat belt assemblies
Head restraints/head rests	Seat belt anchorage brackets, plates, and reinforcements
Labeling requirements	Seat belt routing
	Seat position/adjustment capability

**TYPE 3** The following statement is applicable to all types of incomplete vehicles contained in this document with respect to any seats, seat belt assemblies or seat belt assembly anchorages installed by the intermediate or final stage manufacturer (unless otherwise noted on the cover).

Conformity with CMVSS 210.2 cannot be determined based upon the components supplied on the incomplete vehicle, and General Motors makes no representation to conformity with the standard.

**CMVSS 212 and FMVSS 212 – WINDSHIELD MOUNTING**  
**Applies to all types of Incomplete Vehicles Contained in this Document**

**TYPE 2** The following statement is applicable to all types of incomplete vehicles contained in this document with a 4536 kg (10,000 lb) GVWR or less (unless otherwise noted on the cover).

This incomplete vehicle, when completed, will conform to CMVSS 212 and FMVSS 212 if no alterations are made which affect the function, physical, chemical, or mechanical properties, environment, location or vital spatial clearances of the components, assemblies or systems including but not limited to those listed below:

Air bag crash sensors  
 Air bag system including covers and module  
 Air bag system wiring harnesses, connectors, and fuses/relays  
 Dash panel and cowl assembly  
 Doors and hinge assemblies  
 Frame assembly and mounting system  
 Front impact bar assembly and mounting system  
 Hood and hinge assemblies  
 Powertrain and powertrain mounting system  
 Seat anchorages  
 Seat assemblies  
 Seat belt anchorages

Seat belt assemblies  
 Sensor Diagnostic Module (SDM) and retainers/brackets  
 Steering control system including related hardware  
 Steering wheel, column, and shaft assembly  
 Sun visor assemblies  
 Vehicle/body front sheet metal components/reinforcements  
 Vehicle/body front structural components/reinforcements  
 Vehicle/body roof structure and components  
 Windshield and windshield mounting system  
 Windshield frame/frame reinforcement

During a 48 kph (30 mph) frontal barrier impact test, no component installed by any intermediate or final stage manufacturer shall move forward from its permanently mounted position.

**CMVSS 213.4 and FMVSS 213 – BUILT-IN CHILD RESTRAINT SYSTEMS  
 AND BUILT-IN BOOSTER CUSHIONS**  
**Applies to all types of Incomplete Vehicles contained in this Document**

**TYPE 3** The following statement is applicable to all types of incomplete vehicles contained in this document (unless otherwise noted on the cover).

Conformity with CMVSS 213.4 and FMVSS 213 cannot be determined based upon the components supplied on the incomplete vehicle, and General Motors makes no representation to conformity with the standard.

**CMVSS 214 and FMVSS 214 – SIDE IMPACT PROTECTION**  
**Applies to all types of Incomplete Vehicles contained in this Document**  
**4536 kg (10,000 lb) GVWR or less – Static**  
**4536 kg (10,000 lb) GVWR or less – Dynamic (Oblique Vehicle to Pole Impact)**  
**2722 kg (6,000 lb) GVWR or less – Dynamic (Side Moving Deformable Barrier)**

**TYPE 2** The following statement is applicable to all types of incomplete vehicles contained in this document with the General Motors allowable unloaded vehicle weight of 2400 kg (5,290 lb) or less (unless otherwise noted on the cover).

This incomplete vehicle, when completed, will conform to CMVSS 214 and FMVSS 214, provided the General Motors supplied Tunnel Brace and Fasteners are installed per the directions in the **Cadillac Master Coachbuilders Guidelines Manual** and the applicable maximum GVWR and GAWR's are not exceeded, and no alterations are made which affect the function, physical, chemical, or mechanical properties, environment, location or vital spatial clearances of the components, assemblies or systems including but not limited to those listed below:

Air bag crash sensors  
 Air bag system including covers and module  
 Air bag system wiring harnesses, connectors, and fuses/relays  
 Body roof structure and components  
 Body sheet metal components/reinforcements  
 Door assemblies  
 Door hinges  
 Door latch mechanisms  
 Door latch strikers and striker plates  
 Door latches  
 Door pillars  
 Door trim panels

Door wedges  
 Door window mechanisms  
 Frame  
 Seat airbags  
 Seat anchorages  
 Seat assemblies and adjusters  
 Seat belt anchorages  
 Seat belt assemblies  
 Sensor Diagnostic Module (SDM) and retainers/brackets  
 Side curtain airbag system (if equipped)  
 Upper interior trim including headliner

**CMVSS 216 and FMVSS 216a – ROOF CRUSH RESISTANCE**  
**Applies to all types of Incomplete Vehicles contained in this Document**  
**with a 2722 kg (6,000 lb) GVWR or less**

**TYPE 3** The following statement is applicable to all types of incomplete vehicles contained in this document (unless otherwise noted on the cover).

Conformity with CMVSS 216 and FMVSS 216/216a cannot be determined based upon the components supplied on the incomplete vehicle, and General Motors makes no representation to conformity with the standard.

**CMVSS 219 and FMVSS 219 – WINDSHIELD ZONE INTRUSION**  
**Applies to all types of Incomplete Vehicles contained in this Document**  
**with a 4536 kg (10,000 lb) GVWR or less**

**TYPE 2** The following statement is applicable to all types of incomplete vehicles contained in this document (unless otherwise noted on the cover).

This incomplete vehicle, when completed, will conform to CMVSS 219 and FMVSS 219 providing:

A. No alterations are made which affect the function, physical, chemical, or mechanical properties, environment, location or vital spatial clearances of the components, assemblies or systems including but not limited to those listed below:

Antennae	Hood assembly
Body roof structure and components/reinforcements	Hood mounts
Body sheet metal components/reinforcements	Motor compartment structure and components
Body structural components/reinforcements	Windshield wiper
Dash panel and cowl structure	Windshield wiper motor
Front, rear and side glazing materials and mounting	

B. The vehicle does not exceed the vehicle test weight specified in the FUEL ECONOMY AND EMISSIONS TABLE located within section PART II found later in this document.

C. During a 48 kph (30 mph) frontal barrier impact test:

1. No component installed by any intermediate or final stage manufacturer shall prevent the hood from folding in its designed folding pattern; and
2. No component installed by any intermediate or final stage manufacturer shall penetrate the windshield or protected zone.

**CMVSS 220 and FMVSS 220 – SCHOOL BUS ROLLOVER PROTECTION**  
**For all types of Incomplete Vehicles Contained in this Document using CMVSS 220 or FMVSS**  
**220 as an Alternative Compliance procedure for CMVSS 216 or FMVSS 216a**

**TYPE 3** The following statement is applicable to all types of incomplete vehicles contained in this document (unless otherwise noted on the cover).

Conformity with CMVSS 220 and FMVSS 220 cannot be determined based upon the components supplied on the incomplete vehicle, and General Motors makes no representation to conformity with the standard.

**FMVSS 225 – CHILD RESTRAINT ANCHORAGE SYSTEMS**  
**Applies to all types of Incomplete Vehicles Contained in this Document**  
**3855 kg (8,500 lb) GVWR or less**



**TYPE 1 The following statement is applicable to all types of incomplete vehicles contained in this document with seats installed by General Motors (unless otherwise noted on the cover).**

This incomplete vehicle, when completed, will conform to FMVSS 225 provided the original equipment seats are not replaced, no seating positions are removed or added, and no alterations are made which affect the function, physical, chemical, or mechanical properties, environment, location or vital spatial clearances of the components, assemblies or systems, as manufactured by General Motors, including but not limited to those listed below:

- |  |  |
|--|--|
| Child restraint system including lower and top tether anchorages, seat brackets, plates and reinforcements | Owner Manual instructions                                |
| Access to top tether and lower anchorage systems   | Seat assemblies  |
| Floor pan assembly   | Seat belt assemblies                                     |
| Head restraints/head rests   | Seat belt anchorage brackets, plates, and reinforcements |
|  | Seat belt routing  |
|  | Seat position/adjustment capability                      |

**TYPE 3 The following statement is applicable to all types of incomplete vehicles contained in this document with seat or seat belt delete options in any seating position (unless otherwise noted on the cover).**

Conformity with FMVSS 225 cannot be determined based upon the components supplied on the incomplete vehicle, and General Motors makes no representation to conformity with the standard.

**CMVSS 301 and FMVSS 301 – FUEL SYSTEM INTEGRITY**  
**Applies to all types of Incomplete Vehicles contained in this Document**  
**with a 4536 kg (10,000 lb) GVWR or less**

**TYPE 2 The following statement is applicable to B05 – Armored Vehicle, V4U – Limousine, or W30 – Short Stretch Livery types of incomplete vehicles contained in this document with a 4536 kg (10,000 lb) GVWR or less and a General Motors allowable unloaded vehicle weight of 2400 kg (5,290 lb)–or less (unless otherwise noted on the cover).**

This incomplete vehicle, when completed, including the installation of all General Motors supplied reinforcements per the **Cadillac Master Coachbuilders Guidelines Manual**, will conform to CMVSS 301 and FMVSS 301 provided it is completed in accordance with the following specific conditions by the (intermediate and) final stage manufacturer:

A. The following items when installed by General Motors will conform provided no alterations are made which affect the function, physical, chemical, or mechanical properties, environment, location or vital spatial clearances of the components, assemblies or systems including but not limited to those listed below:

- |   |  |
|---|--|
| Fuel filler door assembly                     | Fuel tank filler neck/pipe fasteners                 |
| Fuel filter                                   | Fuel tank filler neck/pipe hose clamp/clamp assembly |
| Fuel hose shields                             | Fuel tank filler neck/pipe housing assembly          |
| Fuel pipes and hose assemblies                | Fuel tank filler neck/pipe plate                     |
| Fuel system                                   | Fuel tank filler neck/pipe vent hose                 |
| Fuel system attaching or protective structure | Fuel tank filler neck/pipe vent hose clamp/strap     |
| Fuel system fasteners and retainers           | Fuel tank meter assembly                             |
| Fuel tank assembly                            | Fuel tank shields                                    |
| Fuel tank cap assembly                        | Fuel vapor lines and canister assembly               |
| Fuel tank filler neck hose                    |  |
| Fuel tank filler neck/pipe assembly           |  |

B. This incomplete vehicle, when completed, will conform to CMVSS 301 and FMVSS 301 Fuel System Integrity if:

1. No alterations are made to the fuel system and attaching or protective structure, the body structure, the chassis structure, the tires and wheels.
2. During all barrier impact tests:

- a. No component installed by any intermediate or final stage manufacturer impinges or causes distortion to the fuel system with sufficient energy to puncture or separate the fuel system.
- b. No vehicle modification by any intermediate or final stage manufacturer results in any portion of the vehicle impinging upon or causing distortion to the fuel system with sufficient energy to puncture or separate the fuel system. Care should be taken that the structural integrity of the vehicle is restored following any modification of the structure.
- c. Any body installed by an intermediate or final stage manufacturer is mounted securely to absorb loads and prevent movement relative to the frame which could cause any fuel system component to be punctured, separated or otherwise damaged when tested to applicable procedures of CMVSS 301 or FMVSS 301.

**TYPE 3 The following statement is applicable to option B9Q - Funeral Coach (unless otherwise noted on the cover).**

Conformity with CVMSS 301 and FMVSS 301 cannot be determined based upon the components supplied on the incomplete vehicle, and General Motors makes no representation to conformity with the standard.

**CMVSS 302 and FMVSS 302 - FLAMMABILITY OF INTERIOR MATERIALS**  
**Applies to all types of Incomplete Vehicles contained in this Document**

**TYPE 1 The following statement is applicable to all types of incomplete vehicles contained in this document (unless otherwise noted on the cover).**

This incomplete vehicle, when completed will conform to CMVSS 302 and FMVSS 302 providing no alterations are made which affect the function, physical, chemical, or mechanical properties, environment, location or vital spatial clearances of the components, assemblies or systems, as manufactured by General Motors, including but not limited to those listed below:

- |   |                      |
|---|----------------------|
| All trim panels including door, front, rear and side panels | Instrument panel     |
| Arm rests   | Seat assemblies      |
| Compartment shelves   | Seat backs           |
| Console   | Seat belts           |
| Engine compartment covers                                   | Seat cushions        |
| Floor coverings   | Shades               |
| Head restraints   | Sun visors           |
| Headlining  | Wheel housing covers |

NOTE: The list above also includes any other interior materials, such as padding and crash-deployed elements that are designed to absorb energy on contact by occupants in the event of a crash.

**TYPE 3 The following statement is applicable to all types of incomplete vehicles contained in this document (unless otherwise noted on the cover). If the intermediate or final stage manufacturer installs any items but not limited to those listed above (examples: Curtains, Engine compartment cover, Mattress covers, Shades and Wheel housing covers, etc.), they must also meet the requirements of this CMVSS 302 and FMVSS 302.**

Conformity with CMVSS 302 and FMVSS 302 cannot be determined based upon the components supplied on the incomplete vehicle, and General Motors makes no representation to conformity with the standard.

**CMVSS 401 and FMVSS 401 – INTERNAL TRUNK RELEASE**  
**Applies to all types of Incomplete Vehicles contained in this Document**

**TYPE 1 The following statement is applicable to B05 – Armored Vehicle, V4U – Limousine or W30 – Short Stretch types of incomplete vehicles contained in this document (unless otherwise noted on the cover).**

This incomplete vehicle, when completed will conform to CMVSS 401 and FMVSS 401 provided no alterations are made which affect the **function**, physical, chemical, or mechanical properties, environment, location or vital spatial

clearances of the components, assemblies or systems including but not limited to those listed below, and installed by General Motors:

Internal trunk release luminescent label	Remote trunk release system
Internal trunk release manual release mechanism	Trunk latch and striker system
Rear deck lid hinge and counterbalance mechanisms	

**TYPE 3** The following statement is applicable to B9Q – Funeral Coach type of incomplete vehicle contained in this document (unless otherwise noted on the cover).

Conformity with CMVSS 401 and FMVSS 401 cannot be determined based upon the components supplied on the incomplete vehicle, and General Motors makes no representation to conformity with the standard.

**FMVSS 403 – PLATFORM LIFT SYSTEMS**  
**Applies to all types of Incomplete Vehicles contained in this Document**

**TYPE 3** The following statement is applicable to all types of incomplete vehicles contained in this document (unless otherwise noted on the cover).

Conformity with FMVSS 403 cannot be determined based upon the components supplied on the incomplete vehicle, and General Motors makes no representation to conformity with the standard.

**FMVSS 404 – PLATFORM LIFT INSTALLATIONS IN MOTOR VEHICLES**  
**Applies to all types of Incomplete Vehicles contained in this Document**

**TYPE 3** The following statement is applicable to all types of incomplete vehicles contained in this document (unless otherwise noted on the cover).

Conformity with FMVSS 404 cannot be determined based upon the components supplied on the incomplete vehicle, and General Motors makes no representation to conformity with the standard.

## PART II

### U.S. EPA, CALIFORNIA, AND CANADIAN EXHAUST & EVAPORATIVE EMISSION REQUIREMENTS AND EPA/NHTSA GREENHOUSE GAS EMISSIONS/FUEL ECONOMY REGULATIONS

Incomplete vehicles come in three major classifications: (1) Light Duty Vehicles, Light Duty Trucks, and Heavy Duty Vehicles (Including Medium Duty in California) are certified by the primary manufacturer and the vehicle is labeled as being in compliance with emission and fuel economy requirements. (2) Heavy Duty Vehicles are required to have an engine certified by the engine manufacturer and bear an engine emissions label, and if a gasoline vehicle, bear an evaporative emissions label. (3) Light Duty Vehicles certified and labeled by the intermediate or final stage vehicle manufacturer as being in compliance with emission and fuel economy requirements.

In addition, all gasoline/gasoline-ethanol blend powered Federal/California Light Duty, Medium Duty and Heavy Duty Vehicles are required to have an approved fuel evaporative emission control system. Vehicles certified to Heavy Duty gasoline emission standards also require special evaporative emission labeling. In order to assure that Environmental Protection Agency (EPA), National Highway Traffic Safety Administration (NHTSA), California and Canada Emission Certification and/or Greenhouse Gas/Fuel Economy regulations are met, this vehicle must be completed in strict accordance with all instructions contained in this manual, especially the following instructions which relate to:

#### EMISSION RELATED COMPONENTS

**TYPE 1 The following statement is applicable to all types of incomplete vehicles contained in this document (unless otherwise noted on the cover).**

- A. This incomplete vehicle, when completed, will conform to U.S. EPA, CALIFORNIA, AND CANADIAN EXHAUST & EVAPORATIVE EMISSION REQUIREMENTS AND EPA/NHTSA GREENHOUSE GAS EMISSIONS/FUEL ECONOMY REGULATIONS providing the vehicle is completed in strict accordance with all statements included in this document, especially those that relate to: "EMISSION RELATED COMPONENTS, and no alterations are made which affect the function, physical, chemical, or mechanical properties, environment, location or vital spatial clearances of the components, assemblies or systems, as manufactured by General Motors, including but not limited to those listed below (if equipped):

Air Injection Reaction (AIR) System

Axle

Brake System

Catalytic Converter

Components for All Wheel Drive (AWD) System:

axle, Power Take-Off Unit (PTU), propshaft

Diesel Exhaust Emission Reduction Fluid (DEF)

system, including, but not limited to: associated plumbing, fill neck assembly heated delivery line, heater, injector, level sensor, pump, sensors, tank temperature sensor

Diesel Exhaust System, including, but not limited to:

NOx Sensors, NOx Sensor Control Module, Diesel Exhaust (HCI) Direct Fuel Injector System, associated plumbing, injectors, injector controller and calibrations

Diesel/Bio-Diesel blend Particulate Filter (DPF)

system, including, but not limited to: diesel/bio-diesel blend particulate filter assembly diesel/bio-diesel blend oxidation catalyst assembly, exhaust system pressure differential assembly and/or plumbing, exhaust temperature sensor

Engine Assembly, including, but not limited to:

cooling fan and drive system, crankcase emission control system, evaporative emission control system, Exhaust Gas Recirculation (EGR) system, fuel delivery and injection system, glow plugs, Glow Plug Control Module (GPCM), ignition system, Positive Crankcase Ventilation (PCV) system

Engine Electronics, including, but not limited to:

coolant temperature sensor, ECM/GPCM/PCM/VCM, engine speed sensor, mass air flow sensor, calibrations/software

Exhaust oxygen sensors

Exhaust system

Intake System, including, but not limited to: air induction components/system ducts, filter, mass air flow sensor, intake air heater

Onboard Diagnostics Emission System

Tires and Wheels

Transaxle/Transmission Assembly

Transaxle/Transmission Electronics, including, but not limited to: calibrations/software Transmission Control Module (TCM)

Turbo Charging System, associated equipment and controls

- B. The front and rear tires pressures must be inflated to the values shown in the FUEL ECONOMY AND EMISSIONS TABLE that appears below.
- C. The Frontal Area and Vehicle Test Weight shown in the FUEL ECONOMY AND EMISSIONS TABLE that appears below must not be exceeded.

NOTES: All Federal/California gasoline/gasoline-ethanol blend powered heavy duty vehicles (except those equipped with option NJ2, Temporary Fuel Tank) will have an evaporative emission control system that is certified for a fuel tank capacity not to exceed the amount shown on the Vehicle Emission Control Information Label. Intermediate or Final Stage Manufacturers wishing to add fuel tank capacity beyond the original equipment fuel tank capacity must contact California Air Resources Board and/or submit a written statement to the EPA Administrator that the Hydrocarbon Storage System has been upgraded according to the requirements of 40 CFR 86.095-35 (g) (2).

Vehicles equipped with option NJ2 - Temporary Fuel Tank do not have an evaporative emission control system.

- D. Further compliance with applicable fuel evaporative emission regulations will be maintained if no alterations are made to the fuel filler neck

Compliance with applicable fuel evaporative emission regulations will be maintained if no alterations are made to change material or increase the size or length or position of the following non-metallic fuel and evaporative emission hoses:

- |                                       |   |
|---------------------------------------|---|
| Fuel feed hoses front and rear        | Fuel vapor lines at canister                  |
| Fuel return hoses front and rear      | Fuel vapor lines from engine to chassis pipes |
| Fuel tank filler hoses to filler neck | Fuel vapor lines from fuel tank sender        |
| Fuel tank vent hoses to filler neck   | to chassis pipes                              |

- E. This incomplete vehicle, when completed, will have an estimated fuel economy value determined in accordance with 40 CFR Part 600. This value is displayed on a fuel economy label prepared in accordance with the United States Environmental Protection Agency's fuel economy regulations by General Motors and furnished with this vehicle.

This incomplete vehicle, when completed, must not exceed the "Maximum Completed Vehicle Curb Weight" in the FUEL ECONOMY AND EMISSIONS TABLE shown below. To do so will invalidate the fuel economy value determined by the GM Powertrain – Emission Compliance and Certification Group, General Motors, and the emissions certification issued by the United States Environmental Protection Agency or the state of California, where applicable.

This incomplete vehicle, when completed, must not exceed the maximum body frontal area, listed below (specific per vehicle), and must not exceed the total Road Load Horsepower (RLHP) setting, listed below (per vehicle and weight class). To do so will invalidate the fuel economy value determined by the GM Powertrain – Emission Compliance and Certification Group, General Motors and the emissions certification issued by the United States Environmental Protection Agency or the state of California where applicable. RLHP setting and measuring procedures are described in Mobile Source Air Pollution Control Advisory Circular number 55c, for twin roll dynamometer procedures and EPA's Dear Manufacturer guidance letter VPCD-98-16 for single roll procedures, both of which are available from the United States Environmental Protection Agency.

### FUEL ECONOMY AND EMISSIONS TABLE

Incomplete Vehicle Type	GM Tire Size	Cold Tire Pressure Front		Cold Tire Pressure Rear		Frontal Area		RLHP Setting		Vehicle Test Weight Class		Maximum Completed Vehicle Curb Weight	
		psi	kpa	psi	kpa	ft <sup>2</sup>	m <sup>2</sup>	hp	kw	kg	lb	kg	lb
W30	235-55-R18 Extra Load	36	250	36	250	25.8	2.398	14.9	11.0	2041	4,500	1957	4,325
W30	235-55-R18 Extra Load	36	250	36	250	25.8	2.398	15.2	11.2	2155	4,750	2075	4,575

Incomplete Vehicle Type	GM Tire Size	Cold Tire Pressure Front		Cold Tire Pressure Rear		Frontal Area		RLHP Setting		Vehicle Test Weight Class		Maximum Completed Vehicle Curb Weight	
		psi	kpa	psi	kpa	ft <sup>2</sup>	m <sup>2</sup>	hp	kw	kg	lb	kg	lb
W30	235-55-R18 Extra Load	36	250	36	250	25.8	2.398	15.5	11.4	2268	5,000	2188	4,825
W30	235-55-R18 Extra Load	36	250	36	250	25.8	2.398	15.7	11.5	2381	5,250	2302	5,075
W30	235-55-R18 Extra Load	36	250	36	250	25.8	2.398	16.1	11.8	2495	5,500	2468	5,450
B05	235-55-R18 Extra Load	42	290	42	290	25.8	2.398	16.3	12.0	2722	6,000	2699	5,950
V4U	235-55-R18 Extra Load	42	290	42	290	25.8	2.398	14.9	11.0	2155	4,750	2075	4,575
V4U	235-55-R18 Extra Load	42	290	42	290	25.8	2.398	15.2	11.2	2268	5,000	2188	4,825
V4U	235-55-R18 Extra Load	42	290	42	290	25.8	2.398	15.4	11.3	2381	5,250	2302	5,075
V4U	235-55-R18 Extra Load	42	290	42	290	25.8	2.398	15.8	11.6	2495	5,500	2472	5,450
V4U	235-55-R18 Extra Load	42	290	42	290	25.8	2.398	16.3	12.0	2722	6,000	2699	5,950
B9Q	235-55-R18 Extra Load	42	290	42	290	30.3	2.816	17.2	12.7	2155	4,750	2075	4,575
B9Q	235-55-R18 Extra Load	42	290	42	290	30.3	2.816	17.4	12.8	2268	5,000	2188	4,825
B9Q	235-55-R18 Extra Load	42	290	42	290	30.3	2.816	17.7	13.0	2381	5,250	2302	5,075
B9Q	235-55-R18 Extra Load	42	290	42	290	30.3	2.816	18.0	13.2	2495	5,500	2472	5,450
B9Q	235-55-R18 Extra Load	42	290	42	290	30.3	2.816	18.5	13.6	2722	6,000	2699	5,950

NOTES: The "Vehicle Test Weight" (shown above) includes the weight of a vehicle with standard equipment, oil, lubricants, coolant and a full tank of fuel also including 136 kg (300 lb) to allow for the weight of two 68 kg (150 lb) passengers.

"Vehicle Curb Weight" (shown above) is defined as the weight of a "completed vehicle" with standard equipment, oil, lubricants, coolant and a full tank of fuel. Note: This definition may differ from definitions used by governmental regulatory agencies.

**SPECIFICATION FOR FILL PIPES AND OPENINGS OF 2016 AND SUBSEQUENT MODEL MOTOR VEHICLE FUEL TANKS (APPLICABLE ONLY TO CALIFORNIA GASOLINE/GASOLINE-ETHANOL BLEND POWERED VEHICLES)**

**TYPE 2** The following statement is applicable to all types of incomplete vehicles contained in this document (unless otherwise noted on the cover).

This incomplete vehicle, when completed, will conform to Title 13, California Code of Regulations Section 2235, and the "Specifications for Fill Pipes and Openings of 2015 and subsequent Model Year Motor Vehicle Fuel Tanks", dated March 22, 2012, providing no alterations are made which affect the function, physical, chemical, or mechanical properties, environment, location or vital spatial clearances of the fuel filler neck.

**LABELS**

**TYPE 2** The following statement is applicable to all types of incomplete vehicles contained in this document (unless otherwise noted on the cover).

This incomplete vehicle, when completed, will conform to U.S. EPA, CALIFORNIA, AND CANADIAN EXHAUST & EVAPORATIVE EMISSION REQUIREMENTS AND EPA/NHTSA GREENHOUSE GAS EMISSIONS/FUEL ECONOMY REGULATION labeling requirements providing no alterations are made which affect the function,

physical, chemical, or mechanical properties, environment, location or vital spatial clearances of the Emission Control related Information Labels that are permanently affixed. The labels are required by government regulation and must not be obstructed from view or defaced to impair their visibility or legibility. In addition, an EPA/DOT Fuel Economy and Environment Label may be affixed to the window glass of the incomplete vehicle as manufactured by General Motors. If equipped, the label must remain in place until this vehicle is received by the ultimate customer.

# NOTES

---