



Subject: Removal/Deletion - Rear Fuel Tank

Models Years Affected: 2015 - 2019

Models Affected: Chevrolet Silverado/GMC Sierra
3500 HD Chassis Cabs

Origination Date: June 7, 2018

Revision Date: N/A

ADVISORY:

Condition/Concern:

Some vehicle upfits of the Chevrolet Silverado and GMC Sierra 3500HD Chassis Cabs required the removal/deletion of the rear fuel tank to install upfit equipment. The following will provide instructions on the removal/addition of the necessary hardware to reconfigure the vehicle's fuel system from a dual (N2N) to a single front/side mounted (N2M) fuel tank system. Be advised that following the fuel system reconfiguration certain modules on the vehicle must be reprogram for the fuel system components to function properly.

Repair/Recommendation:

Gasoline (L96/LC8) Engine Applications – Rear Fuel Tank Removal (2015-2019MY)

1. Relieve the fuel system pressure.
 - a. Remove the fuel pump fuse.
 - b. Loosen the fuel fill cap to relieve the fuel tank vapor pressure.
 - c. Remove the engine cover, if required.
 - d. Remove the fuel rail service port cap.
 - e. Wrap a shop towel around the fuel rail service port and using a small flat-bladed tool, depress (open) the fuel rail test port valve.
 - f. Remove the shop towel from around the fuel rail service port, and place in an approved gasoline container.
 - g. Install the fuel rail service port cap.
 - h. Install the engine cover, if required.
 - i. Tighten the fuel fill cap.
2. Raise the vehicle.

For lifting the vehicle, various lift points are recommended. Before you begin any lifting procedure, place the vehicle on a clean, hard, level surface. Verify that all the lifting equipment meets weight standards and is in good working order. Verify that all of the vehicle loads are equally distributed and secure. If you are only supporting the vehicle at the frame side rails, verify that the lifting equipment does not put too much stress on, or weaken, the frame side rails.

General Motors Upfitter Integration

<http://www.gmupfitter.com>

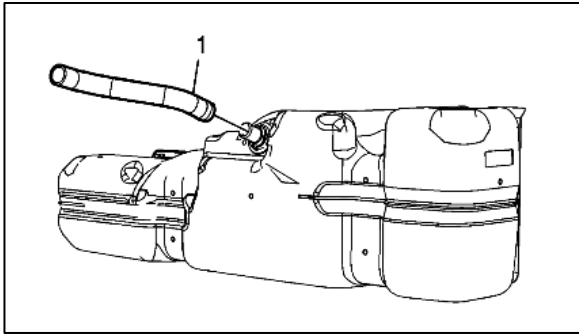

3. Drain the fuel tank.
 - a. Loosen the fuel fill hose clamp (1).
 - b. Remove the fuel fill hose from the fuel tank.
 - c. Remove the flame arrester screen from the tank opening, if required.
 - d. Insert the hose from the pump device into the fuel tank.
 - e. Using a hand or air operated pump device, drain as much fuel from the tank as possible.

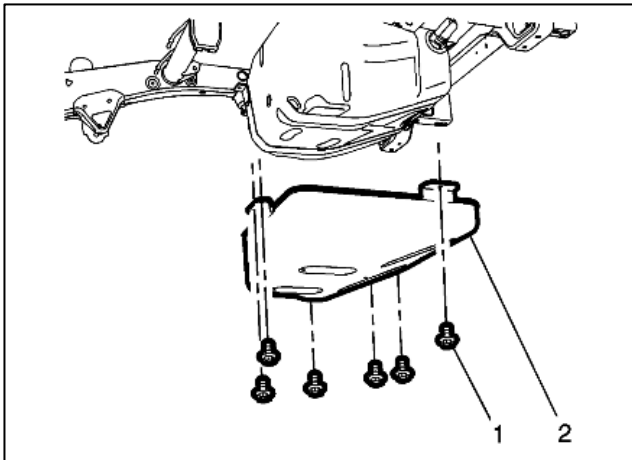

4. Remove the fuel tank shield bolts (1) and the fuel tank shield (2).

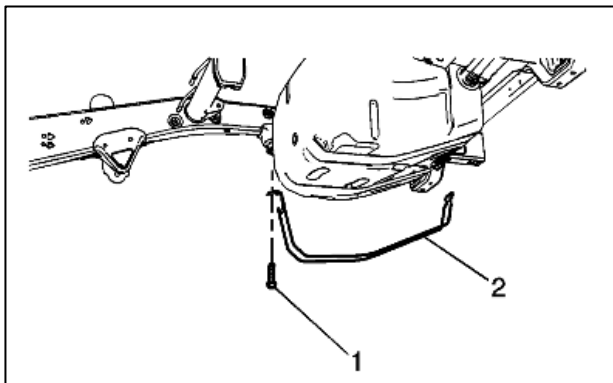

5. Support the fuel tank with a suitable jack.
6. Remove the fuel tank strap fastener (1).

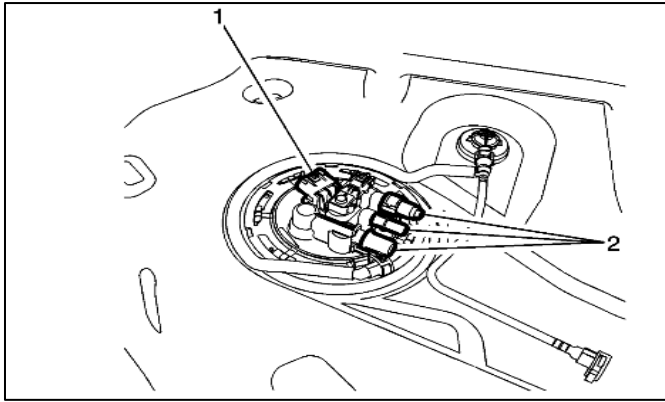

7. Lower the tank enough to access the fuel pump module.
8. Disconnect the electrical connector (1) and the evaporative emissions lines and the fuel lines (2). Properly secure the wires as they will no longer be used.
9. Lower the fuel tank.

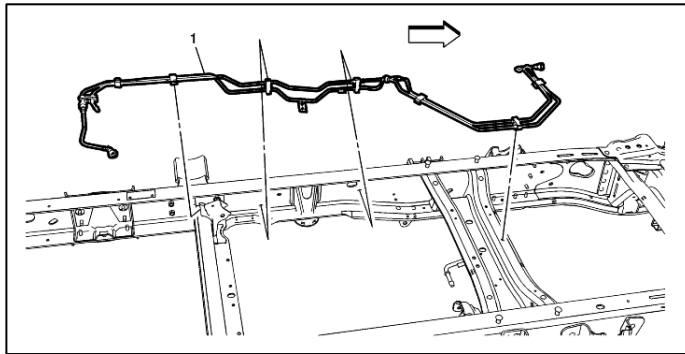

10. Disconnect the quick connect fittings and remove the fuel lines from the rear fuel tank to front/side fuel tank.

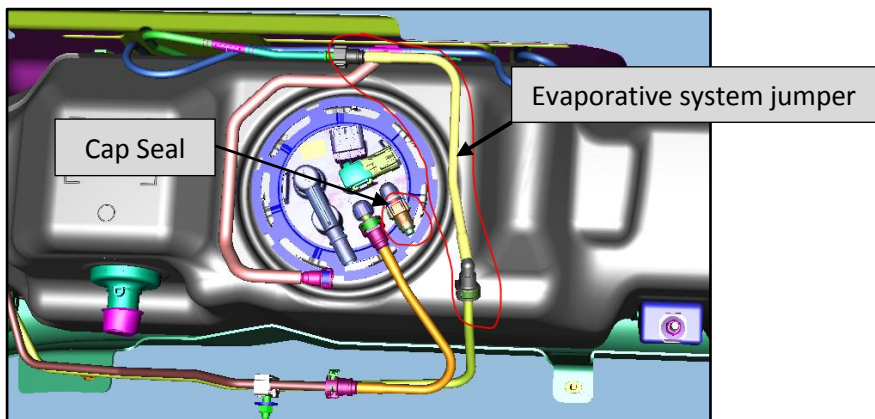

11. Install evaporative system jumper P/N 25989389
12. Install fuel port cap P/N 23287870 or equivalent cap seal.



**Diesel Engine Applications – Rear Fuel Tank Removal
2015-2016 Model Years (LML).**

1. Drain the fuel tank.
 - a. Disconnect the negative battery cable.
 - b. Remove the fuel fill cap.
 - c. Raise and suitably support the vehicle. Refer to Lifting and Jacking the Vehicle.
 - d. Insert a hose into the tank.
 - e. Attach the hose to a hand or air operated pump device.
 - f. Using a hand or air operated pump drain as much fuel from the tank as possible.

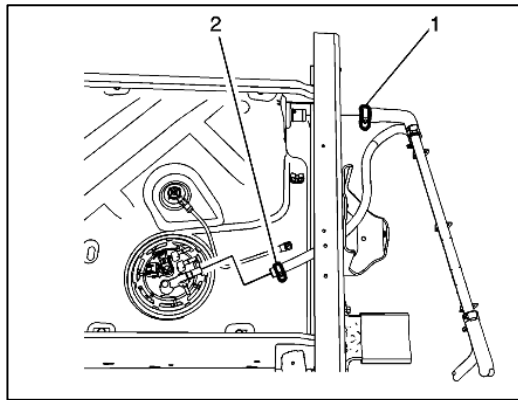

2. Loosen the fuel fill and vent hose clamps (1, 2) at the tank.
3. Remove the fuel fill and vent hose from the tank.

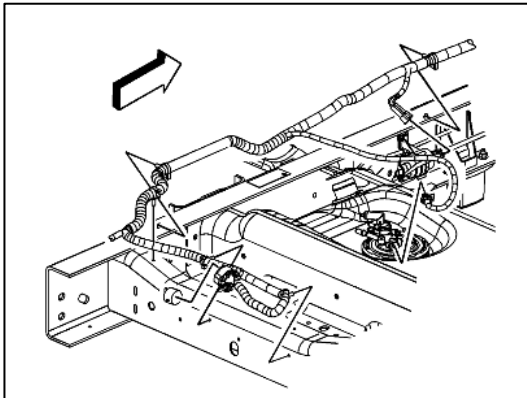

4. Disconnect the sending unit electrical connector

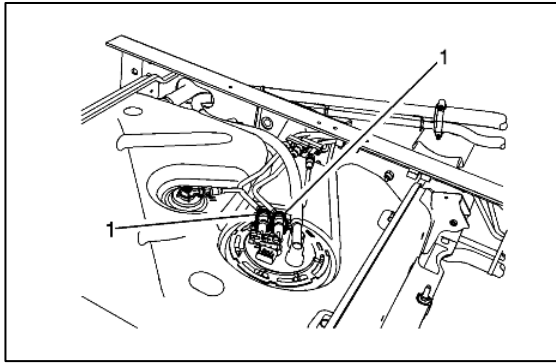

5. Disconnect the fuel feed and return lines (1) from the sending unit.
6. Raise and suitably support the vehicle.

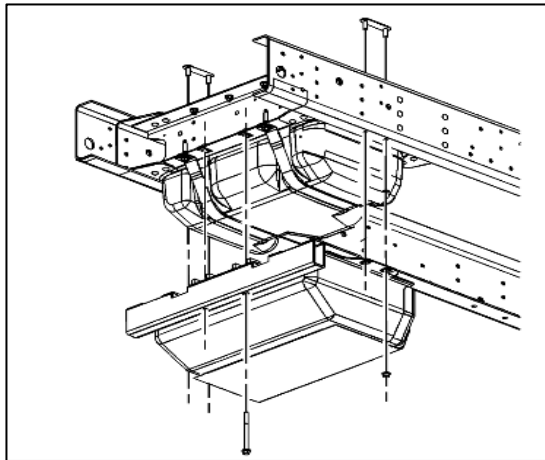

7. Remove the fuel tank shield bolts.
8. Remove the fuel tank shield.

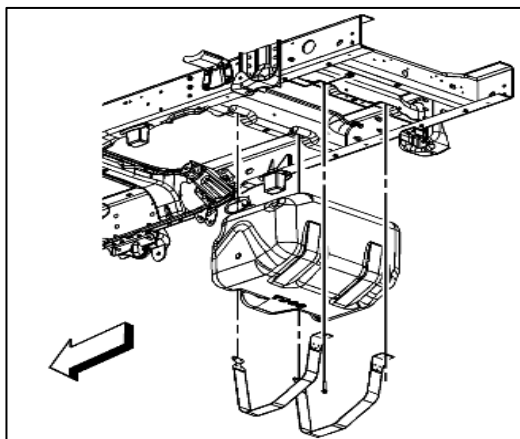

9. Remove the fuel tank strap bolts.
10. Remove the fuel tank straps.
11. Lower the fuel tank.
12. With the aid of an assistant, place the fuel tank in a suitable work area.
13. Cap the fuel lines to prevent possible fuel system contamination.

General Motors Upfitter Integration

<http://www.gmupfitter.com>

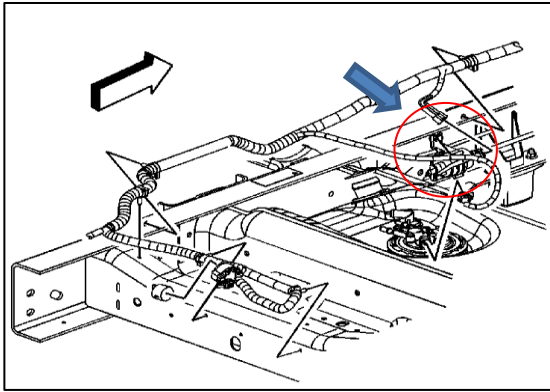

14. Disconnect the pressure balance pump electrical connector

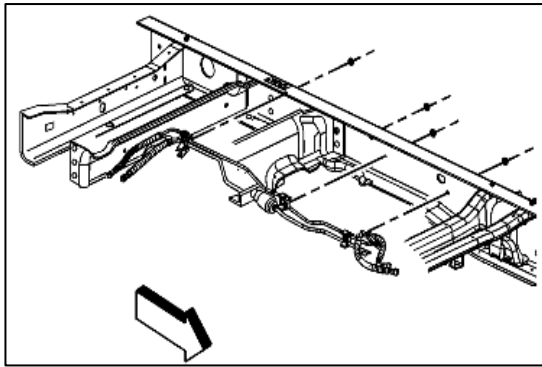

15. Remove the fuel bundle nuts.

16. Remove the fuel bundle and pressure balance pump.

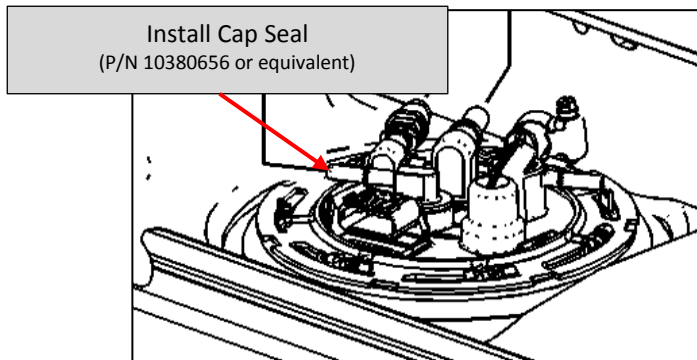

17. Install a cap seal on the fuel inlet port from rear tank.



2017-2019 Model Years (L5P).

1. Drain the fuel tank.
 - a. Disconnect the negative battery cable.
 - b. Remove the fuel fill cap.
 - c. Raise and suitably support the vehicle. Refer to Lifting and Jacking the Vehicle.
 - d. Insert a hose into the tank.
 - e. Attach the hose to a hand or air operated pump device.
 - f. Using a hand or air operated pump drain as much fuel from the tank as possible.
2. Raise and support the vehicle

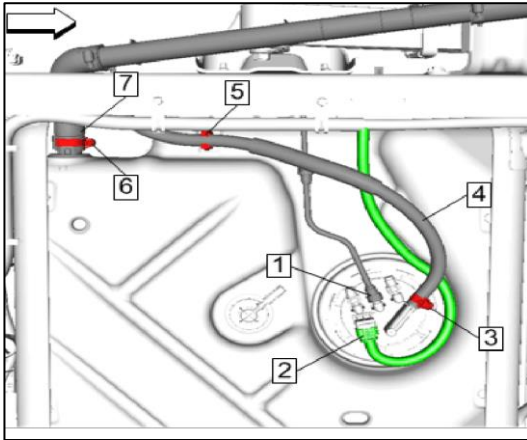

3. Disconnect Fuel Feed Rear Hose (1)
4. Disconnect Electrical Connector (2)
5. Remove Fuel Tank Filler Vent Hose Clamp (3)
6. Remove Fuel Tank Filler Vent Hose (4)
7. Remove Fuel Tank Filler Vent Hose (4) @ Retainer (5)
8. Remove Fuel Tank Filler Hose Clamp (6)
9. Remove Fuel Tank Filler Hose (7)

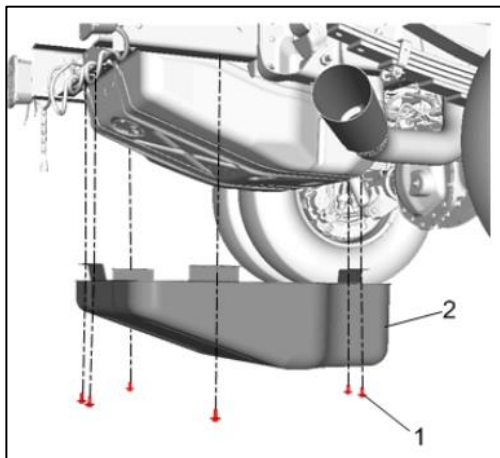

10. Remove [6x] Fuel Tank Shield Auxiliary Bolts (1)
11. Remove Fuel Tank Auxiliary Shield (2)

General Motors Upfitter Integration

<http://www.gmupfitter.com>

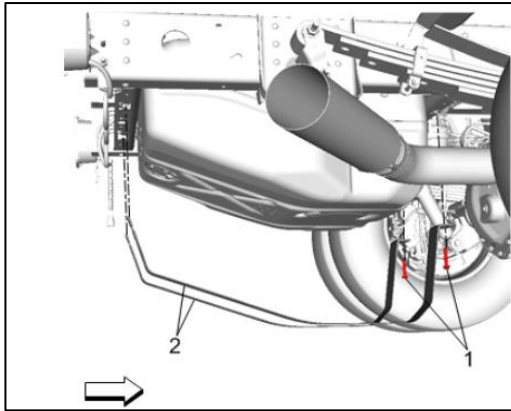

- 12. Place a suitable adjustable jack under the fuel tank.
- 13. Remove the Auxiliary Fuel Tank Strap Bolts (1).
- 14. Remove the Auxiliary Fuel Tank Straps (2).

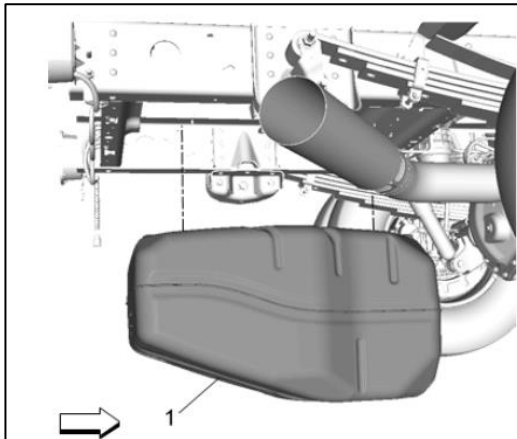

- 15. Remove Auxiliary Fuel Tank(1)

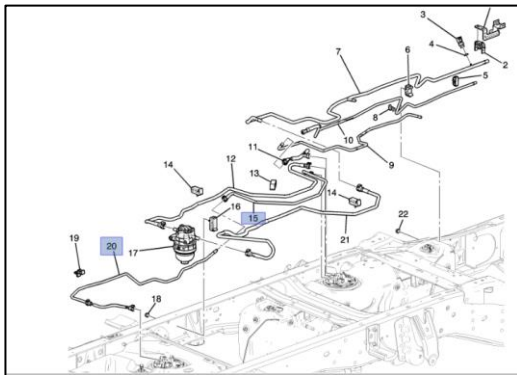

- 16. Remove the lines (15 & 20) from the rear tank to the front tanks.

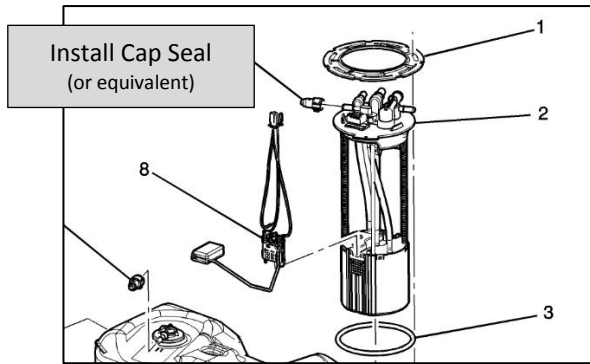

17. Cap the fuel inlet port which the fuel line from the rear tank was connected with a suitable cap and clamp.

Additional Information:

Upon completion of the fuel system hardware reconfiguration, it is necessary to reprogram the vehicle's **Engine Control Module (ECM)** by a GM dealer to enable proper fuel gauge operation and level indication.

GM DEALERS:

Contact Techline Customer Support and request the vehicle configuration string be modified, replacing the dual fuel tank option (N2N) with the single front/side fuel tank option (N2M). Be sure to check for and clear any DTCs that may be present following the vehicle reconfiguration.

FOR TCSC USE:

| Free Flow RPO | Ref. Only RPO | Description | Work Truck | LT |
|---------------|---------------|--|------------------|------------------|
| | | | 1WT ¹ | 1LT ¹ |
| | | 1 - Available on all models. | | |
| | N2N | Fuel tank, front and rear, 63.5 gallon | S | S |
| N2L | | Fuel tank, rear only, 40 gallon 1 - Requires Duramax 6.6L Turbo-Diesel Engine | A ¹ | A ¹ |
| N2M | | Fuel tank, front only, 23.5 gallon | A | A |