



UI Bulletin #122b

Subject: CHMSL/Cargo Lamp Wiring For Aftermarket Bed Cap Topper

Models Affected: 2014 Chevrolet Silverado 1500
2015-2018 Chevrolet Silverado
2014 GMC Sierra 1500
2015-2018 GMC Sierra

Date: December 4, 2014

Revision Date: April 20, 2018

ADVISORY:

Reference: GM Service Information - PIT5314b

Condition/Concern:

Some owners that have installed an aftermarket bed cap or topper may question where they can wire in the Center High Mount Stop Lamp (CHMSL) for the cap or topper. Provisions for the CHMSL have been provided in the following locations:

2016-2018 model years - Connector X400 terminal 4 circuit 1054.

2014-2015 model years - Rear Body Junction Block (X63A) connector X6 terminal 1 circuit 1054.

Repair/Recommendation:

Follow the recommendations listed below based on the model year of the vehicle.

2016-2018 model years

Perform the following recommendations based on vehicle configuration:

1. For vehicles built WITH Under-rail Bed Lighting Option:

Trucks equipped with the under-rail bed lighting option will already have the female side of the X400 connector. Obtain an appropriate length of 18g. wire to run from the X400 connector up to the CHMSL wiring for the cap or topper. Use terminal part # 60012931 in AFL Tray 21, along with wire seal part # 60994015 in AFL Tray 21 and connect it to one end of the wire. Disconnect the X400 connector and remove the rubber cavity plug in pin position 4 and discard. Install the terminated lead that was just made into the X400 connector pin 4. Run the wire up to the CHMSL for the cap or topper and connect. The ground for the cap or topper CHMSL will need to be made to an appropriate ground.

2. For vehicles built WITHOUT Under-rail Bed Lighting Option:

Trucks not equipped with the under-rail bed lighting option will have a dummy X400 female connector, which will be removed and discarded. The female side of the X400 connector is not available separately, but can be obtained by ordering the under-rail bed lighting harness GM part number 23327843. The harness will come with terminals/wiring in pin positions 1 and 6. Remove the wiring and terminal from pin location 1 and discard. Move the rubber cavity plug from pin position 4 and reinstall it into pin position 1. Obtain an appropriate length of 18g wire to run from the X400 up to the CHMSL wiring for the cap or topper. Use terminal part # 60012931 in AFL Tray 21, along with wire seal part # 60994015 in AFL Tray 21 and connect it to one end of the wire. Install the terminated lead that was just made into the X400 connector pin location 4. Pin 6 is a ground circuit that is

General Motors Upfitter Integration

<http://www.gmupfitter.com>



UI Bulletin #122b

used for the under-rail bed lighting and it can also be used to ground the CHMSL for the cap or topper if the wire gauge size in the connector is of the proper size for the CHMSL in the cap or topper. If the wire gauge size is too small, any of the following can be done:

- Make a second wire as described above. Then, remove the wiring from pin 6 and discard. Install the new terminated wire in position 6 for the ground and run it up to the CHMSL for the cap or topper and connect.
- Remove the wire and terminal from pin 6 and install a rubber cavity plug.
- Cut the wire for terminal 6, leaving a couple inches of wire, and seal the end of the wire.
- Note: The terminal removal tool for the female side of the X400 connector is J-38125-212.

2014-2015 model years

Perform the following recommendations based on vehicle configuration:

1. For vehicles built WITH Under-rail Bed Lighting Option:

Trucks equipped with the under-rail bed lighting option will already have an X6 connector at the rear body junction block X63A, which will be removed and discarded. Obtain an appropriate length of 14g wire to run from the rear body junction block up to the CHMSL wiring for the cap or topper. Use terminal part # 1-968857-3 in Lear Tray 7, along with wire seal part # 828905-1 in Lear Tray 16 and connect to one end of the wire. Disconnect the X6 connector at the Rear Body Junction Block and remove the rubber cavity plug in terminal position 1 and discard. Install the terminated lead you just made into the X6 connector terminal 1. Run the wire up to the CHMSL for the cap or topper and connect. The ground for the cap or topper CHMSL will need to be made to an appropriate ground.

2. For vehicles built WITHOUT Under-rail Bed Lighting Option:

Trucks not equipped with the under-rail bed lighting option will have a dummy connector at the X6 position of the rear body junction block. The X6 connector body is not available separately, but can be obtained by ordering the under-rail bed lighting harness GM part number 22878806. The harness will come with terminals/wiring in positions 4 and 7. You will need to remove the wiring from terminal 4 and discard. Move the rubber cavity plug from terminal position 1 into terminal position 4. Obtain an appropriate length of 14 ga wire to run from the rear body junction block up to the CHMSL wiring for the cap or topper. Use terminal part # 1-968857-3 in Lear Tray 7, along with wire seal part # 828905-1 in Lear Tray 16 and connect to one end of the wire. Install the terminated lead you just made into the X6 connector terminal 1. Terminal 7 is a ground circuit used for the under-rail bed lighting and it can be used to ground the CHMSL for the cap or topper, if desired. If terminal 7 is not used remove the terminal and install a rubber cavity plug or cut off the additional wiring, leaving a couple inches of wire and seal the end of the wire.



UI Bulletin #122b

X400 Accessory Cargo Kit Harness to Chassis Harness (2016-2018)

<p>Connector Part Information</p> <ul style="list-style-type: none"> • Harness Type: Accessory Cargo Kit • OEM Connector: Not Available • Service Connector: Service by Harness - See Part Catalog • Description: 6-Way F 	<p>Connector Part Information</p> <ul style="list-style-type: none"> • Harness Type: Chassis • OEM Connector: 10865189 • Service Connector: 93185233 • Description: 6-Way M 2.8 Series, Sealed (BK)

Terminal Part Information							
Terminal Type ID	Terminated Lead	Diagnostic Test Probe	Terminal Removal Tool	Service Terminal	Tray Name	Core Crimp	Insulation Crimp
I	Not Required	J-35616-4A (PU)	No Tool Required	Not Required	Not Required	Not Required	Not Required
II	Not Required	J-35616-5 (PU)	No Tool Required	Not Required	Not Required	Not Required	Not Required

X400 Accessory Cargo Kit Harness to Chassis Harness													
Pin	Size	Color	Circuit	Terminal Type ID	Option	Function	Pin	Size	Color	Circuit	Terminal Type ID	Option	
1	0.75	WH/VT	1430	I	—	Exterior Courtesy Lamp Control	1	0.75	WH/VT	1430	II	—	
2-3	—	—	—	—	—	Not Occupied	2-3	—	—	—	—	—	
4	0.5	VT/GY	1054	I	—	Stop Lamp Control	4	0.5	VT/GY	1054	II	—	
5	—	—	—	—	—	Not Occupied	5	—	—	—	—	—	
6	1	BK	1750	I	—	Ground	6	1	BK	1750	II	—	



UI Bulletin #122b

X63A- Rear Junction Block – Connector X6 (2014-2015)

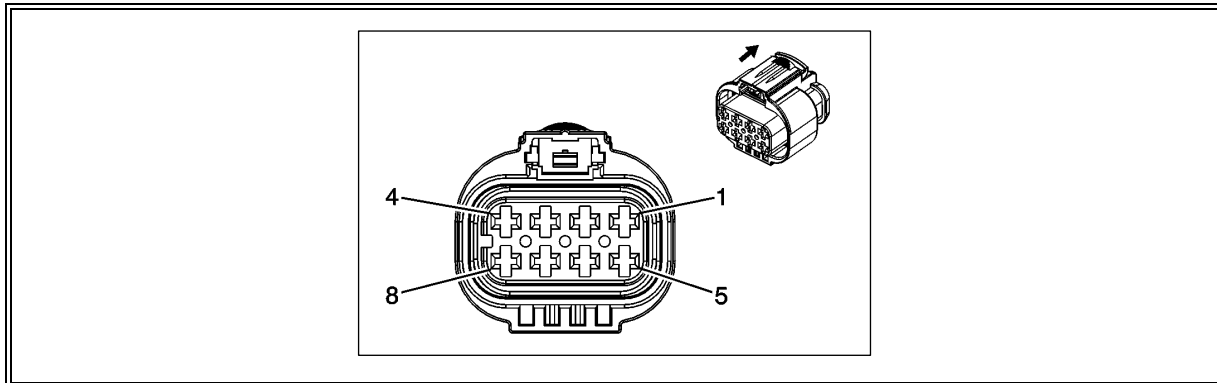

Connector Part Information

- Harness Type: Pending
- OEM Connector: 13581768
- Service Connector: **Not yet available**
- Service by Harness - See Part Catalog
- Description: Rear Bed Cargo Lamp

X63A Junction Block - Rear Body X6						
Pin	Size	Color	Circuit	Function	Terminal Type ID	Option
1	0.75	VT/GY	1054	Stop Lamp Supply Voltage	I	-
2-3	-	-	-	Not Occupied	-	-
4	0.5	RED	1430	Exterior Courtesy Lamp Supply Voltage	I	-
5-6	-	-	-	Not Occupied	-	-
7	0.5	BLK	1750	Ground	I	-