

Subject: Rear Spring Shackle Bolt Length
Models Years Affected: 2007 and beyond
Models Affected: Chevrolet Silverado
GMC Sierra
w/ZW9 or Pick Up Box Removal
Origination Date: September 7, 2016
Revision Date: N/A

ADVISORY:

Condition/Concern:

Upfitter/Service body and equipment installers have often expressed concerns regarding the “extra” length of the rear leaf spring shackle bolts interfering with the installation of the body or equipment.

Repair/Recommendation:

The bolts for rear spring shackles have a hold & drive feature requirement for vehicle assembly. This feature adds extra length to the bolt required for the vehicle assembly process and cannot be eliminated.

IMPORTANT NOTICE: Body Builders/Upfitters can cut the extra length off this bolt, however they **MUST** maintain at least 3 threads **visible** on the end of the bolt after the joint is clamped.

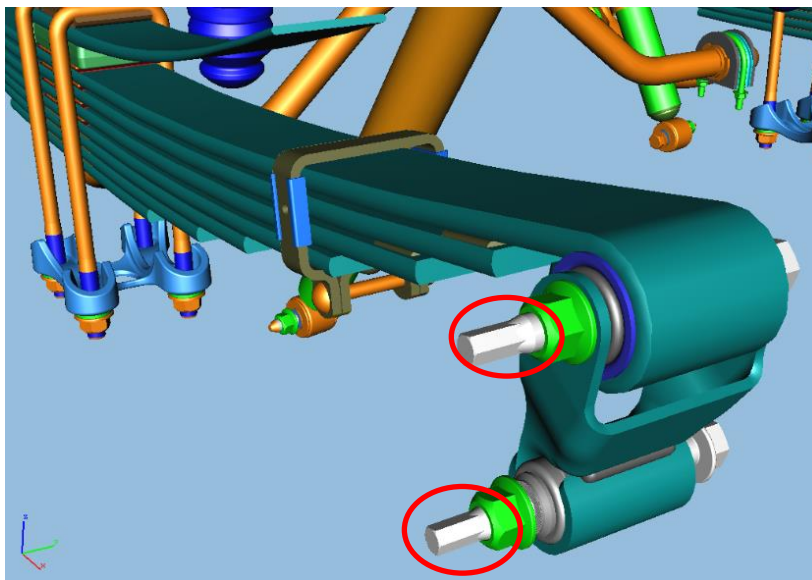

General Motors Upfitter Integration

<http://www.gmupfitter.com>