



Subject Installation of Upfitter (AUX) Switches
 (9L7) components
Model Years 2019 - 2023
Affected
Models Chevrolet Silverado
Affected GMC Sierra
Origination 6/10/2019
Date
Revision June 2, 2023
Date

ADVISORY:

Condition/Concern:

Beginning with the 2019 New Body Light Duty Full Size Pickup Trucks, the Upfitter (AUX) Switch option (9L7) will require, depending on model, some or all components will need to be installed to make the feature fully functional.

The 9L7 upfitter (AUX) switch components consist of the following:

- Knee Bolster
- Switch Bank
- Fuse Kit
- Fasteners (2)
- Aux Fuse Block
- Under Hood Wiring harness
- Retainers

Light Duty models (1500)

These models will require all the listed components to be installed. The components are shipped in various locations within the cab of the truck.

NOTE: Model Year 2022i (VIN 5 digit = A or D) and 2023 Vehicles NOT ordered with the 9L7 option cannot be retrofitted using the kits outlined in this document.

Heavy Duty Models (2500/3500)

These models are currently being manufactured with the switches and appropriate knee bolster yet require remaining components in the list to be installed.

Service Parts Retrofit Kits

The retrofit kits, like the light duty models, will require all components to be installed. The kit part numbers and the list of components within each kit are noted below. The kits are unique as to the interior trim color and to whether the vehicle has a keyed or push to start (BTM) ignition system.

General Motors Upfitter Integration

<http://www.gmupfitter.com>



Kit Usage:

- 84942071 for use with Jet Black interior and keyed ignition (-BTM)
- 84942072 for use with Very Dark Atmosphere Interior and keyed ignition (-BTM)
- 84942073 for use with Jet Black interior and with push button ignition (+BTM)
- 84942074 for use with Very Dark Atmosphere interior and with push button ignition (+BTM)

Kit Components:

Kit #	84942071	84942072	84942073	84942074
Knee Bolster	84487351	84487352	84487354	84487355
Switch Bank	84688687	84688686	84688687	84688686
Fuse Kit	84669070	84669070	84669070	84669070
Fasteners	11589015 (2)	11589015 (2)	11589015 (2)	11589015 (2)
Aux Fuse Block	84645397	84645397	84645397	84645397
Under Hood Wiring harness	84794790	84794790	84794790	84794790
Retainers	11589290	11589290	11589290	11589290

NOTICE:

Installation of the Upfitter (AUX) Switches and supporting components are NOT a GM Warranty or PDI covered labor cost. The installation of the switches/components are intended to be performed by the upfitter as a part of the overall vehicle upfit and the labor cost associated with that installation be covered in the upfitter's estimate to its customer. Installation, when performed by a GM dealer, the labor charges associated with that install are the responsibility of the customer/vehicle purchaser.



Figure 1

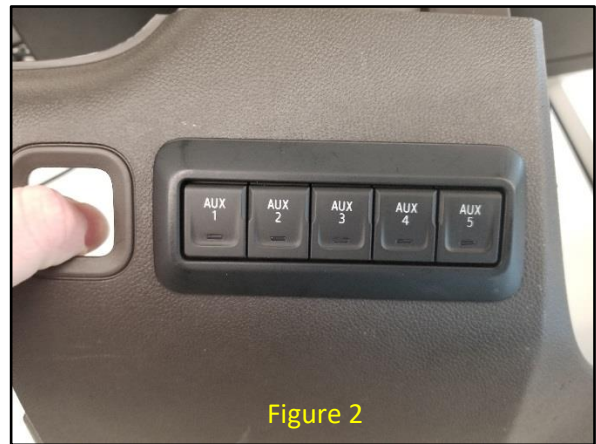

Figure 2



Repair/Recommendation:

To install the Aux switches, the knee bolster may require replacement or may simply need to have a few fasteners removed (if switches are installed during vehicle assembly refer to the vehicle model sections below for details. **NOTE:** Prior to reinstalling the replacement Knee Bolster (if applicable) follow the instructions in bulletin.

Light Duty(1500)/Service Parts Kit

For these vehicle installations the first step is to remove the knee bolster trim panel using the combined service information procedures outlined in the link below, do NOT install the new knee bolster until after performing the steps below.

[Instrument Panel Knee Bolster Replacement](#)

While the knee bolster is removed, the Instrument Panel Auxiliary Fuse Block should be mounted, the connector for the switch bank assembly routed and secured, the gray connector to the IP harness connected, the power cable from the battery ran and secured (not yet connected to the battery) and lastly the fuse kit installed in the Battery Fuse Block. The installation of these components is outline in the steps/sections below.

Electrical Center mounting/connections:

1. Mount the IP Aux. Fuse block using the 2 screws in the locations circled in RED as shown in figure 3

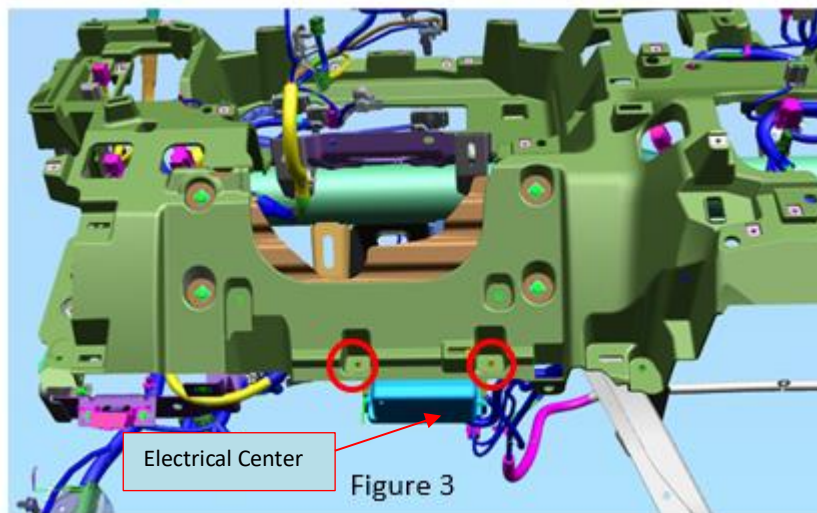



Connect the 14-pin connector Aux Fuse Block to the connector shown in figure 4 (note vehicle is shipped from the assembly plant with a blank connector in place to protect the terminals in the IP Harness. Remove this prior to connecting the connector from the fuse block)

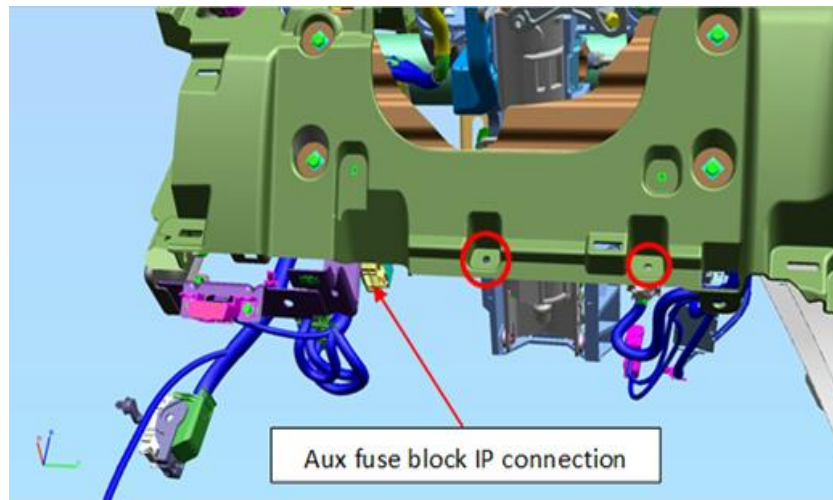

Figure 4

2. Route the 16-pin switch bank connector through the opening in the Instrument Panel as shown in figure 5

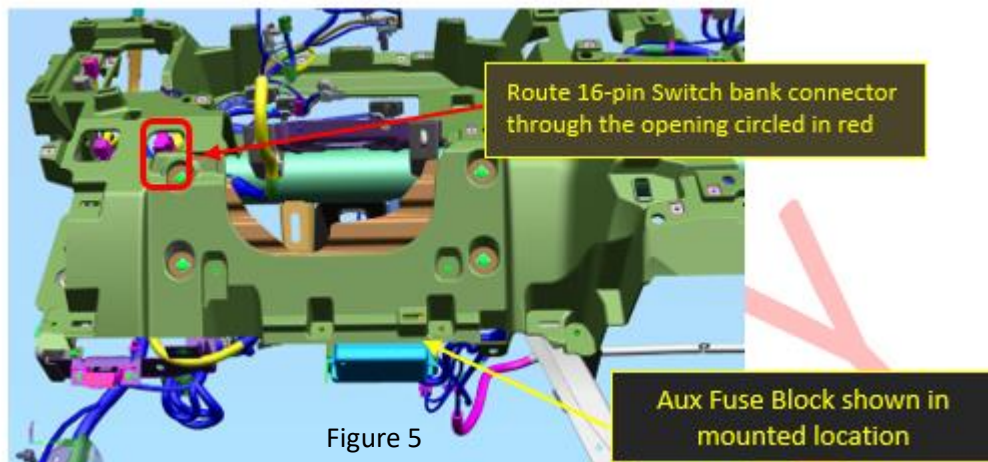

Figure 5

Power Cable installation/routing:

3. Remove the 4 (circled in red) retaining push pins (only) for the Air Inlet Grill as shown in figure 6
4. Secure the power cable using the new supplied push pins by inserting the push pin through the eyelets on the power cable and into the securing locations for the air inlet grill that were previously removed. The power cable end with ring terminal should be routed (**but not yet connected**) to the Battery Distribution Unit (BDU) (the fuse block mount to the top of the primary battery).
5. Route the power cable into the cabin as shown in figure 7 (note do not install wire terminal into connector body until after the cable is routed into the cabin)

General Motors Upfitter Integration

<http://www.gmupfitter.com>

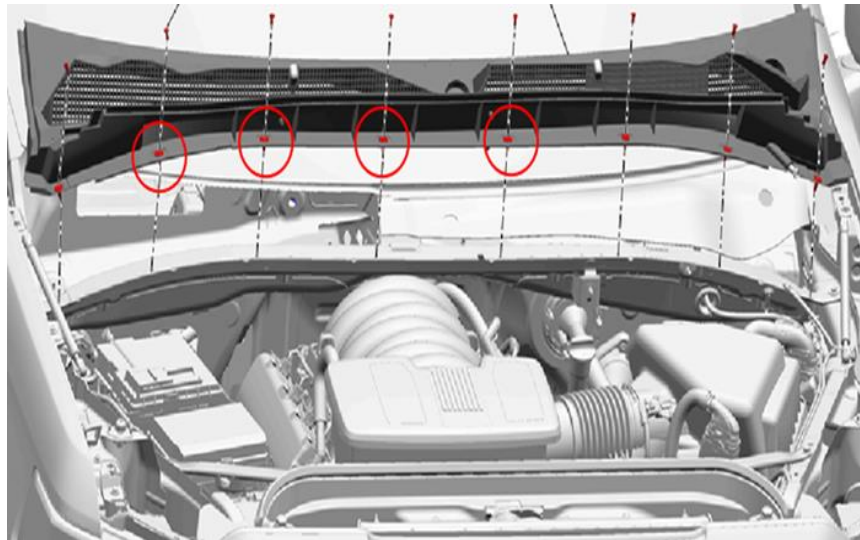

Figure 6

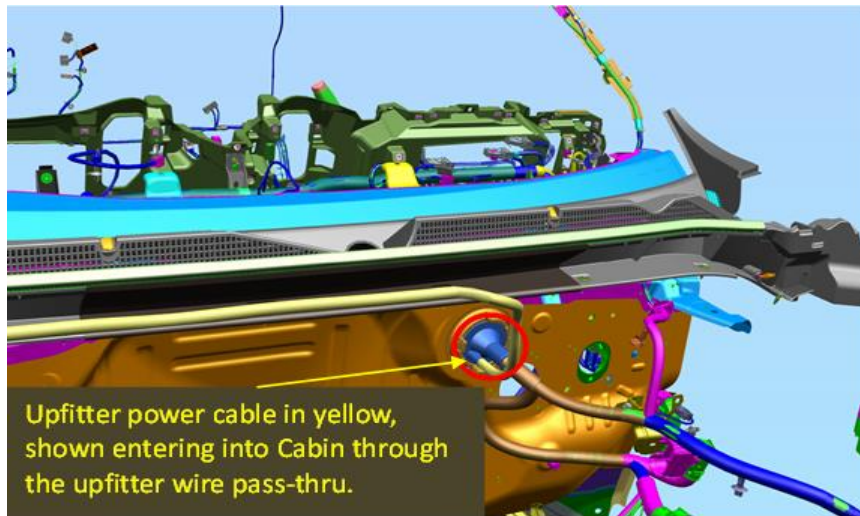

Figure 7

6. Insert terminal on the power cable into the supplied connector body and connect the connector to the Aux. Fuse block
7. Secure any loose wires under the IP/Steering Column area with nylon wire ties to prevent squeaks/rattle and harness rubbing/chaffing conditions

Install switches installed into the new knee bolster trim in the provided cut-out. Connect the switch connector/harness and any other electrical connections – Installed knee bolster and reassemble the removed components per the GM service procedure used to remove the knee bolster



Instrument Panel Knee Bolster Replacement

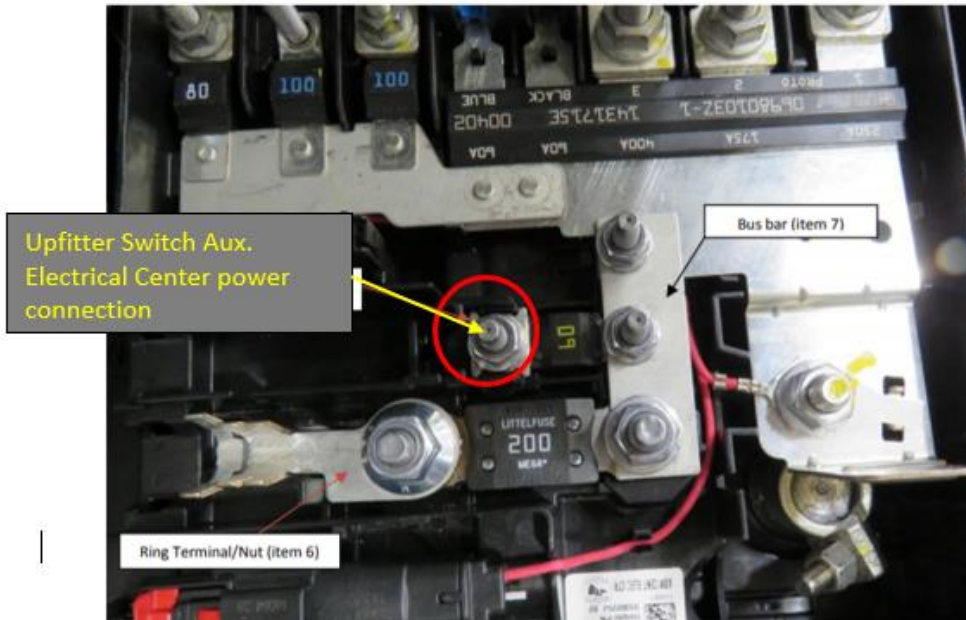

Adding Fuse Kit:

1. Once all “kit” components have been installed, the Aux Fuse Block can now be powered, for detailed instructions on adding the fuses to the battery mounted electrical center refer to the latest revision of UI Bulletin #147. (<http://www.gmupfitter.com/pages/technical-bulletins>)
2. Following the installation of the fuse kit to the battery mounted electrical center, connect the power cable ring terminal to the 60-amp fuse output side stud.

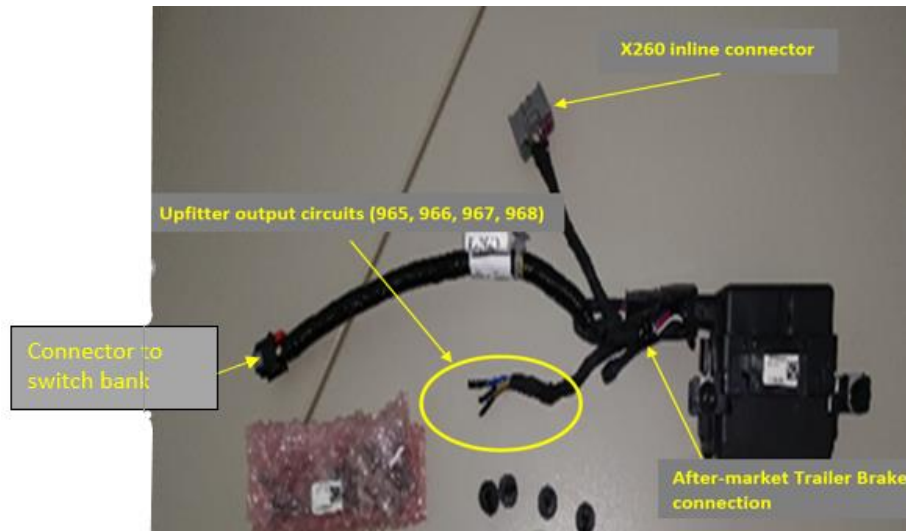



Upfitter Provisions - 1 of 2 (9L7)

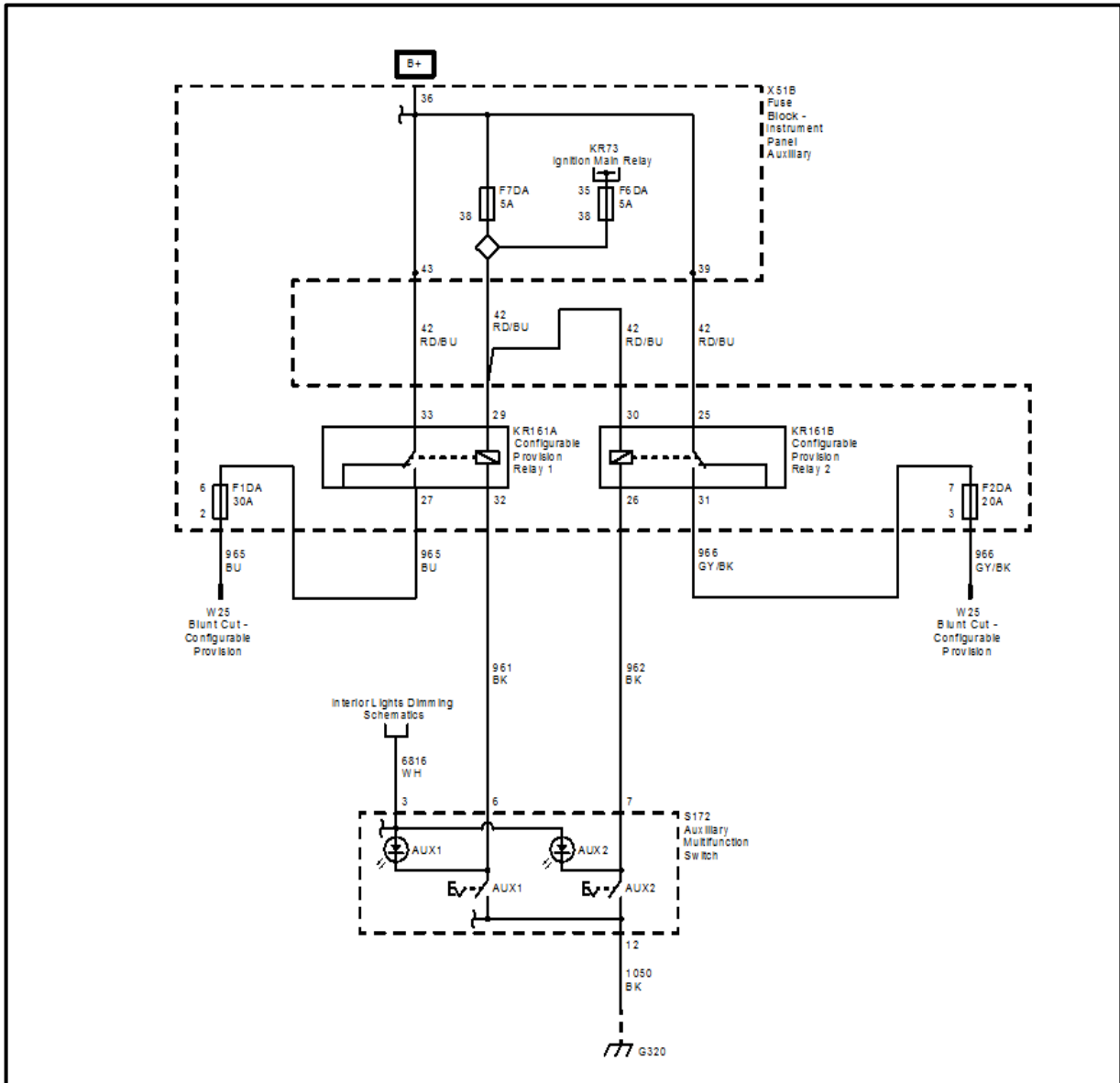



Upfitter Provisions - 2 of 2 (9L7)

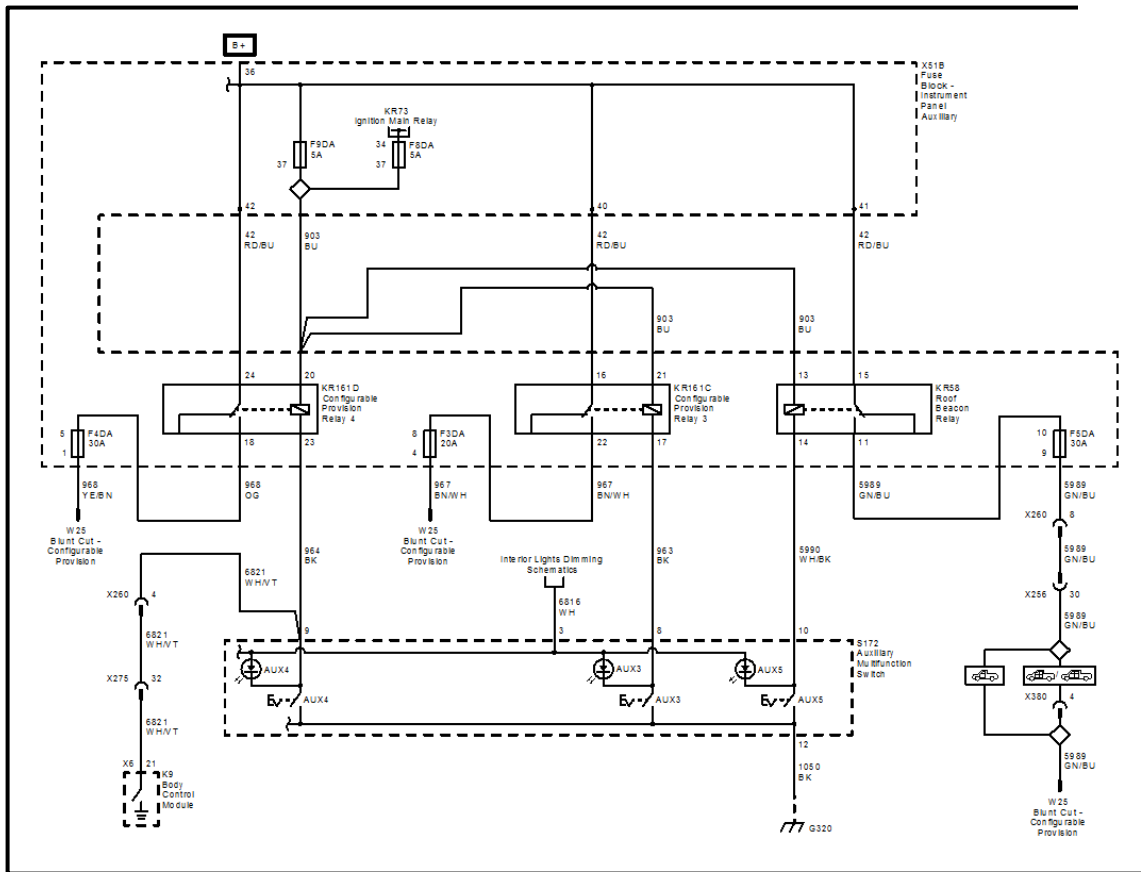



X260 Auxiliary Instrument Panel Harness to Instrument Panel Harness

(For 2019-2022 1500 (LTD) Light Duty models. For 2022i and newer 1500 series refer to the X213 connector pinout table)

<p>Connector Part Information</p> <ul style="list-style-type: none"> • Harness Type: Auxiliary Instrument Panel • OEM Connector: 10847017 • Service Connector: 13513605 • Description: 14-Way F 1.5, 2.8 Series (L-GY) 	<p>Connector Part Information</p> <ul style="list-style-type: none"> • Harness Type: Instrument Panel • OEM Connector: 10846900 • Service Connector: 88956523 • Description: 14-Way M 1.5, 2.8 Series (L-GY)

Terminal Part Information							
Terminal Type ID	Terminated Lead	Diagnostic Test Probe	Terminal Removal Tool	Service Terminal	Tray Name	Core Crimp	Insulation Crimp
I	13587516	J-35616-2A (GY)	No Tool Required	Not Required	Not Required	Not Required	Not Required
II	13575708	J-35616-4A (PU)	No Tool Required	Not Required	Not Required	Not Required	Not Required
III	13575818	J-35616-3 (GY)	J-38125-553	Not Available	Not Available	Not Available	Not Available
IV	13575824	J-35616-5 (PU)	J-38125-11A	7114-4112-02	Yazaki 9	C	D



X260 Auxiliary Instrument Panel Harness to Instrument Panel Harness												
Pin	Size	Color	Circuit	Terminal Type ID	Option	Function	Pin	Size	Color	Circuit	Terminal Type ID	Option
1	0.75	BK	1050	I	—	Ground	1	2	BK	1250	IV	—
2	—	—	—	II	—	Not Occupied	2	—	—	—	—	—
3	0.35	YE	6817	II	—	LED Backlight Dimming Control	3	0.5	YE	6817	III	—
4	0.35	WH/VT	6821	II	—	Surveillance Switch Signal	4	0.35	WH/VT	6821	III	—
5	0.5	WH/BU	3691	II	—	Trailer Brake Apply Signal	5	0.5	WH/BU	3691	III	—
6	—	—	—	II	—	Accessory Voltage	6	0.35	VY/YE	43	IV	—
7	2	RD/VT	1242	I	—	Battery Positive Voltage	7	2	RD/VT	1242	IV	—
8	2.5	GN/BU	5989	I	—	Emergency Lamp Relay Contact Control	8	2.5	GN/BU	5989	IV	—
9	—	—	—	II	—	Out of Park Signal	9	0.35	YE	6812	IV	—
10	—	—	—	II	---	Vehicle Speed Signal	10	0.35	GN/GY	817	IV	—
11	0.35	WH	6816	II	—	Indicator Dimming Control	11	0.35	WH	6816	III	—
12	—	—	—	II	—	Not Occupied	12	—	—	—	—	—
13	0.5	VT/GN	39	II	—	Run/Crank Ignition 1 Voltage	13	0.35	VT/WH	239	III	—
14	2	BU	47	I	—	Trailer Auxiliary Control	14	2	BU	47	IV	—



X213A Auxiliary Fuse Block Wiring Harness to Instrument Panel Wiring Harness (9L7)

For Model Year 2022i (VIN 5 digit = A or D) and 2023 Vehicles

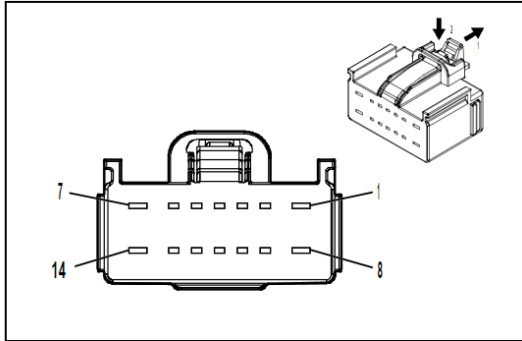

Connector Part Information

Harness Type: Auxiliary Fuse Block Wiring Harness
 OEM Connector: 33366376
 Service Connector: Service by Harness - See Part Catalog
 Description: 14-Way F 1.5, 2.8 YESC Series(GY)

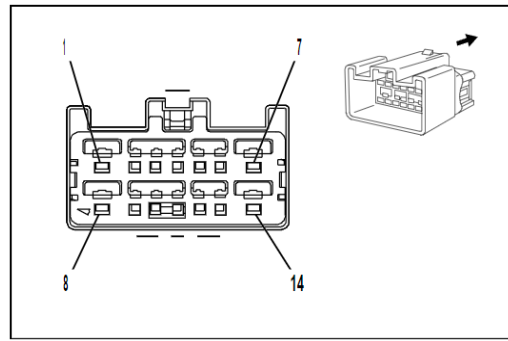

Connector Part Information

Harness Type: Instrument Panel Wiring Harness
 OEM Connector: 10846900
 Service Connector: 88956523
 Description: 14-Way M 1.5, 2.8 YESC Series(L-GY)

Terminal Part Information			
Terminal Type ID	Terminated Lead	Diagnostic Test Probe	Terminal Removal Tool
I	Not required	J-35616-2A (GY)	No Tool Required
II	Not required	J-35616-4A (PU)	No Tool Required
III	13578907	J-35616-3 (GY)	J-38125-215A
IV	13578908	J-35616-5 (PU)	J-38125-11A

X213A Auxiliary Fuse Block Wiring Harness to Instrument Panel Wiring Harness (9L7)

Pin	Size	Color	Circuit	Terminal Type ID	Option	Function	Pin	Size	Color	Circuit	Terminal Type ID	Option
1	0.75	BK / WH	851	II	—	Signal Ground	1	2.5	WH	22	IV	—
2	—	—	—	—	—	Not Occupied	2	—	—	—	—	—
3	0.35	YE	6817	I	—	LED Backlight Dimming Control 1	3	0.35	YE	6817	III	—
4	—	—	—	—	—	Not Occupied	4	—	—	—	—	—
5	0.5	WH / BU	3691	I	—	Trailer Brake Apply Signal	5	0.35	WH / BU	3691	III	—
6	—	—	—	—	—	Not Occupied	6	—	—	—	—	—



7	2.5	RD / BN	4142	II	—	Primary Fused Battery Positive Voltage	7	2.5	RD / BN	4142	IV	—
8	2.5	VT / BU	10735	II	—	Upfitter Accessory 5 Supply Voltage	8	2.5	VT / BU	10735	IV	—
9	—	—	—	—	—	Out of Park Signal	9	0.35	YE	6812	III	—
10	—	—	—	—	—	Vehicle Speed Signal	10	0.35	GN / GY	817	III	—
11	0.35	WH	6816	I	—	Indicator Dimming Control	11	0.35	WH	6816	III	—
12	—	—	—	—	—	Not Occupied	12	—	—	—	—	—
13	0.5	VT / BK	339	I	—	Run/Crank Ignition 1 Voltage	13	0.5	VT / BK	339	III	—
14	2	BU	47	II	—	Trailer Auxiliary Control	14	2	BU	47	IV	—

Additional Information:

The upfitter switches are defaulted to being battery powered, but can be reconfigured in pairs to operate only when in accessory/ignition ON by relocating one or two fuses as shown below

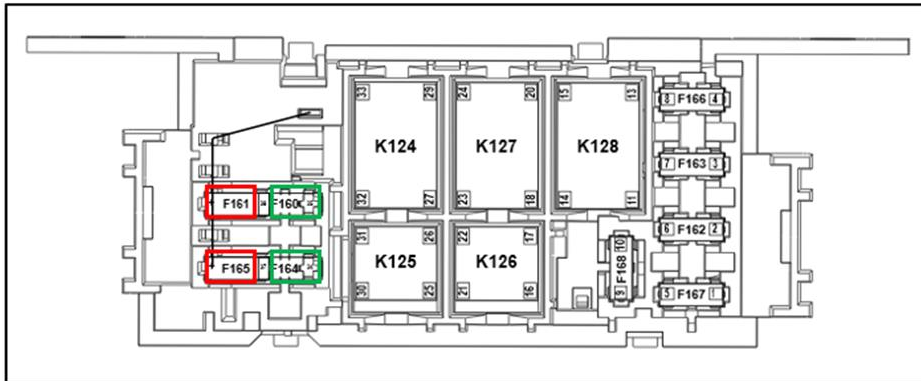

Red = Battery Powered
 Green = Ign. Run/Crank Powered
 Fuse Position 160/161 = Switches 1 and 2
 Fuse Position 164/165 = Switches 3 and 4

Disclaimer: GM Upfitter Integration Technical Bulletins are intended for use by professional technicians, NOT a "do-it-yourselfer". They are written to inform these technicians of conditions that may occur on some vehicles, or to provide information that could assist in the proper service and/or modification of a vehicle. These properly trained technicians have the equipment, tools, safety instructions, and know-how to do a job properly and safely. If a condition is described, DO NOT assume that the bulletin applies to your vehicle, or that your vehicle will have that condition. Contact GM Upfitter Integration for information on whether the information is applicable your vehicle.

