



Subject Installation of Upfitter (AUX) Switches (9L7) components
Model Years Affected 2022i - 2024 - Current
Models Affected Chevrolet Silverado
 GMC Sierra
 Refer to the UI Bulletin Usage table below
Origination Date October 27, 2025
Revision Date N/A

ADVISORY:

<u>UI Bulletin Usage Table</u>			
<u>Model Year(s)</u>	<u>Brand</u>	<u>Model</u>	<u>Bulletin #</u>
2019-2022* (*With VIN Digit 5 = W or Y)	Chevrolet	1500	153e
2019-2022* (*With VIN Digit 5 = 8 or 9)	GMC	1500	153e
2020-2023	Chevrolet	2500/3500	153e
2020-2023	GMC	2500/3500	153e
2022i*- 2024-Current (*With VIN Digit 5 = W or Y)	Chevrolet	1500	193
2022i*- 2024-Current (*With VIN Digit 5 = 8 or 9)	GMC	1500	193
2024 - Current	Chevrolet	2500/3500	193
2024 - Current	GMC	2500/3500	193

Condition/Concern:

Beginning with the 2022i the Full-Size Pickup Trucks, the Upfitter (AUX) Switch option (9L7) will require, depending on model, some or all components will need to be installed to make the feature fully functional. The installation instructions vary by vehicle trim levels and those instructions are broken down by trim option codes.

Install Procedure #1 = Chevy WT (GF5), Custom (GF2), Custom TB (GPZ), and GMC Pro (GFF)

Install Procedure #2 = LT (GG0/GF3), LT TB (GF4), RST (GFC), ZR2 (GRZ), LTZ (GF9), HC (GFD), SLE (GFI), Elevation (GFS/GFJ), SLT (GFU)

Install Procedure #3 = AT4 (GFG), AT4X (GA4), Denali (GFW), Denali Ult (GFY)

Coming soon in later revision

The 9L7 upfitter (AUX) switch components consist of the following:
(components vary based on trim level)

- Knee Bolster or Lower Center Stack Trim Panel (console cover on premium models)
- Switch Bank (first or second design)
- Fuse Kit
- Fasteners (2)
- Aux Fuse Block
- Under Hood Wiring harness
- Retainers

Light Duty models (1500)

These models will require all the listed components to be installed. The components are shipped in various locations within the cab of the truck.

Heavy Duty Models (2500/3500)

These models are currently being manufactured with the switches and appropriate knee bolster/trim panels installed yet require remaining components in the list to be installed.

Service Parts Retrofit Kits

~~The retrofit kits (when available) will require all components to be installed. The kit part numbers and the list of components within each kit are noted below. The kits are unique as to the interior trim color and to whether the vehicle has a keyed or push to start (BTM) ignition system~~

KITS NO LONGER AVAILABLE: ALL PARTS UNDER KIT NUMBERS, RESPECTIVE TO TRIM-LEVEL, IN TABLES BELOW MUST BE ORDERED SEPARATELY.

Kit Usage:

- ~~84942071 for use with Jet Black interior and keyed ignition (-BTM)~~
- ~~84942072 for use with Very Dark Atmosphere Interior and keyed ignition (-BTM)~~
- 84942073 for use with Jet Black interior and with push button ignition (+BTM)
- 84942074 for use with Very Dark Atmosphere interior and with push button ignition (+BTM)

General Motors Upfitter Integration

<http://www.gmupfitter.com>

Kit Components:

Kit #	84942071	84942072	84942073	84942074
Knee Bolster	Not used on 2022i and newer vehicles – Keyed Ign. no longer available	Not used on 2022i and newer vehicles – Keyed Ign. no longer available	84487354	84487355
Switch Bank			84688687	84688686
Fuse Kit			84669070	84669070
Fasteners			11589015 (2)	11589015 (2)
Aux Fuse Block + Switch harness			84645397	84645397
Under Hood Wiring harness			84794790	84794790
Retainers			11589290	11589290

NOTICE:

Installation of the Upfitter (AUX) Switches and supporting components are NOT a GM Warranty or PDI covered labor cost. The installation of the switches/components are intended to be performed by the upfitter as a part of the overall vehicle upfit and the labor cost associated with that installation be covered in the upfitter's estimate to its customer. Installation, when performed by a GM dealer, the labor charges associated with that install are the responsibility of the customer/vehicle purchaser.

Power Cable installation/routing (all trim levels)

To route the power wire harness into the cabin the RH inner wheelhouse liner must be removed to gain access to the "service" port where the wire will be passed though. Select the appropriate removal procedure by vehicle application within the linked document below.

[Combined Front Wheelhouse Liner Replacement procedures](#)

Prior to attempting to pass the wire/harness into the cabin the silver-colored insulation and plastic conduit must be removed, leaving only fabric like tape wrapping on the wire.



The "service port" or wire pass-thru is located at the 6 o'clock position on the wire harness grommet as shown below. The rubber seal inside of the service port will need to have an "X" cut into to provide for the wire to be passed.

General Motors Upfitter Integration
<http://www.gmupfitter.com>

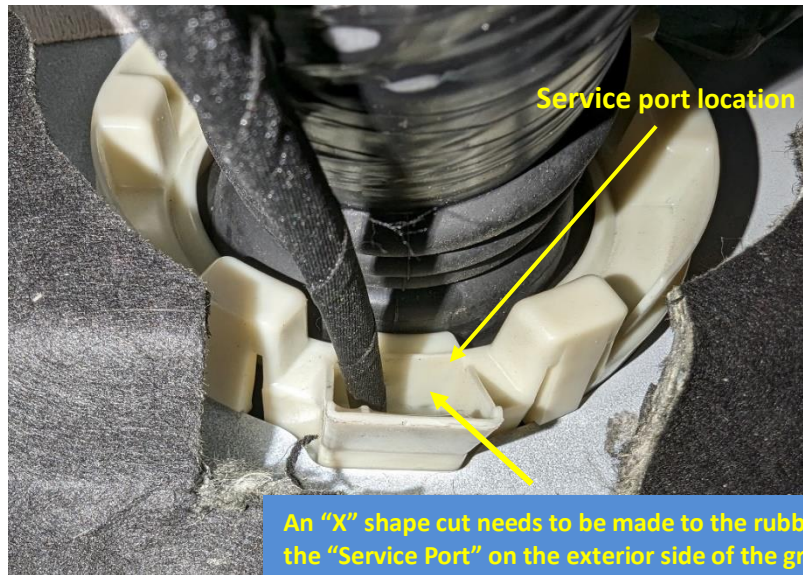

A similar "X" shape cut must be made to the interior cabin side of the grommet located under the IP on the RH side just below the HVAC module— see below

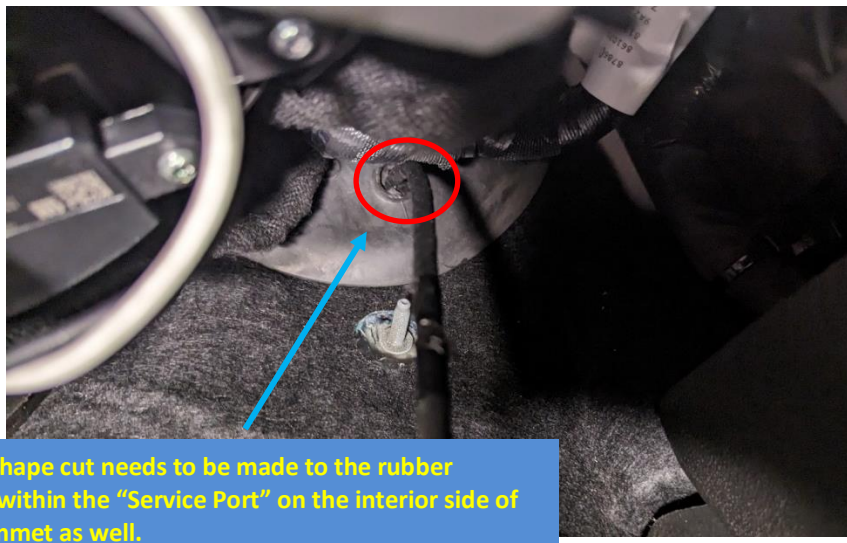

Generously lubricate the exterior area of the service port with glass cleaner. Using a 6" to 8" rigid feeder wire (metal hanger type wire) taped the terminated end (non-ring terminal) of the harness. Feed the rigid feeder wire through the exterior service port using care to ensure the feeder wire exits inside the cab through the X cut. While applying support pressure to the inside X cut area, pull the feeder wire, and harness terminal through the X cut into the cabin. Once the terminated end of the harness is inside the cabin, continue to pull the harness into the cabin and route behind the HVAC duct as shown below. You will need to leave enough of the harness Underhood to route up to the Battery Electrical Center (BEC) as you will adding content to the BEC to power the AUX Electrical Center that will be added in upcoming steps.

General Motors Upfitter Integration
<http://www.gmupfitter.com>

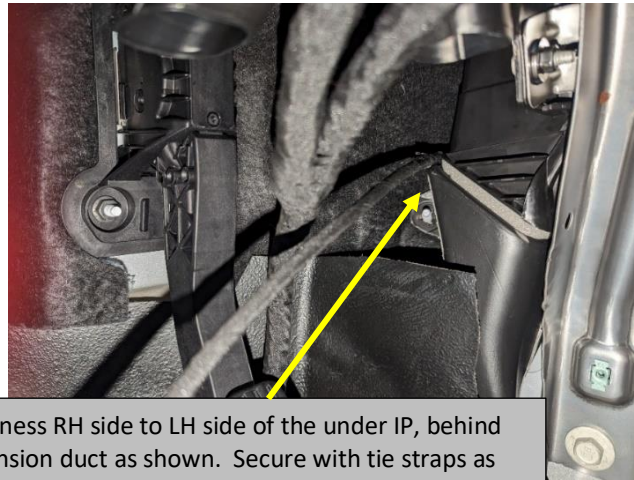

Route wire harness RH side to LH side of the under IP, behind the HVAC extension duct as shown. Secure with tie straps as needed to prevent rattles and drooping down below the IP.

NOTE: For all vehicle trim level applications the components shown below will need to be installed



Install Procedure #1 = Chevrolet WT (GF5), Custom (GF2), Custom TB (GPZ), and GMC Pro (GFF) (Note for the new IP design kits are not yet available use P/Ns for obtaining parts for retrofitting a vehicle not ordered with the 9L7 option)

	Knee Bolster	Switch Bank	Fuse kit	Aux. Fuse Block + Switch harness	Wire Harness	Fasteners
P/N	84487354	85080553	84669070	86812138	84794790	11589015

Note: because these trim levels are carry-over IP from the previous generation of trucks you can use kit part number 84942073 which will include the components shown in the image above. You will not use the retainers as the harness routing has changed and they are no longer needed.

Repair/Recommendation:

To install the Aux switches, the knee bolster may require replacement or may simply need to have a few fasteners removed (if switches are installed during vehicle assembly refer to the

General Motors Upfitter Integration
<http://www.gmupfitter.com>

vehicle model sections below for details. **NOTE:** Prior to reinstalling the replacement Knee Bolster (if applicable) follow the instructions in bulletin.

For these vehicle installations the first step is to remove the knee bolster trim panel using the combined service information procedures outlined in the link below, do NOT install the new knee bolster until after performing the steps below.

[Instrument Panel Knee Bolster Replacement](#)

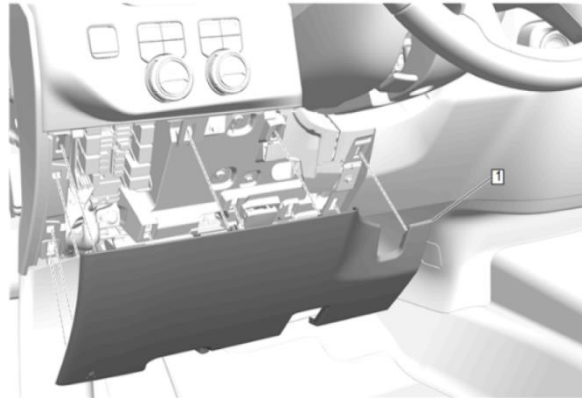

While the knee bolster is removed, the Instrument Panel Auxiliary Fuse Block should be mounted, the connector for the switch bank assembly routed and secured, the gray connector to the IP harness connected, the power cable from the battery ran and secured (not yet connected to the battery) and lastly the fuse kit installed in the Battery Fuse Block. The installation of these components is outline in the steps/sections below.

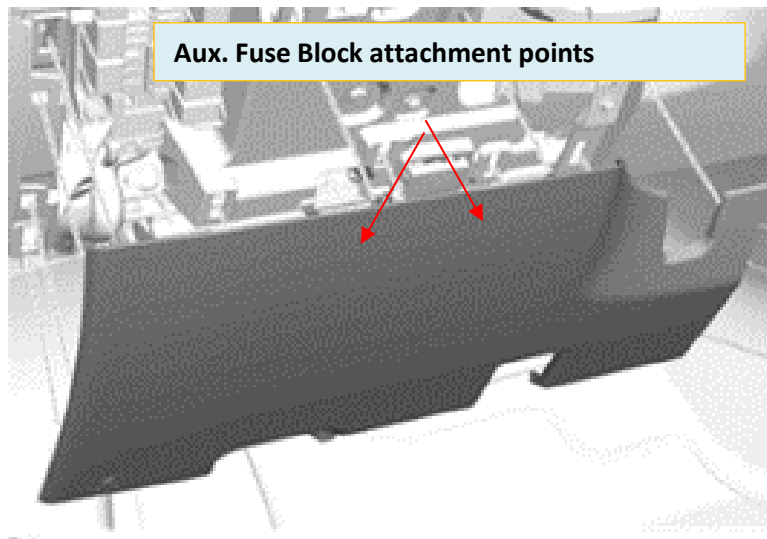



Electrical Center mounting/connections:

1. Mount the IP Aux. Fuse block using the 2 screws in the locations circled in RED as shown in figure 3

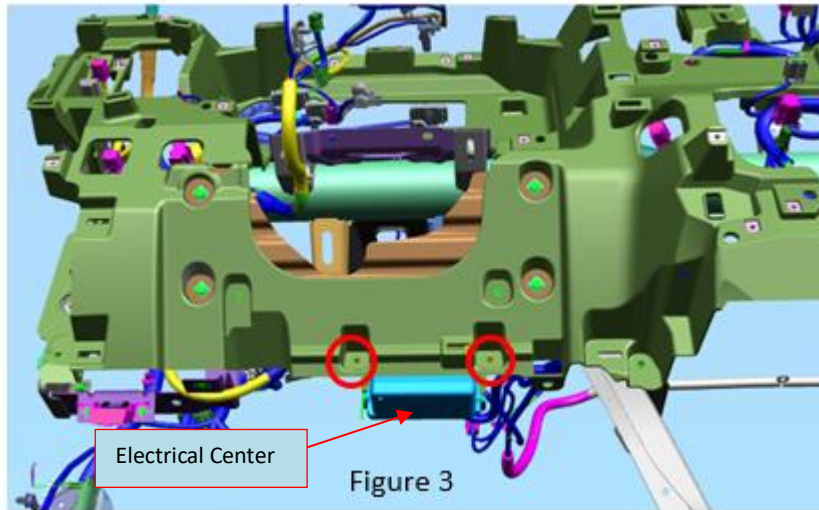

Connect the 14-pin connector Aux Fuse Block to the connector shown in figure 4 (note vehicle is shipped from the assembly plant with a blank connector in place to protect the terminals in the IP Harness. Remove this prior to connecting the connector from the fuse block)

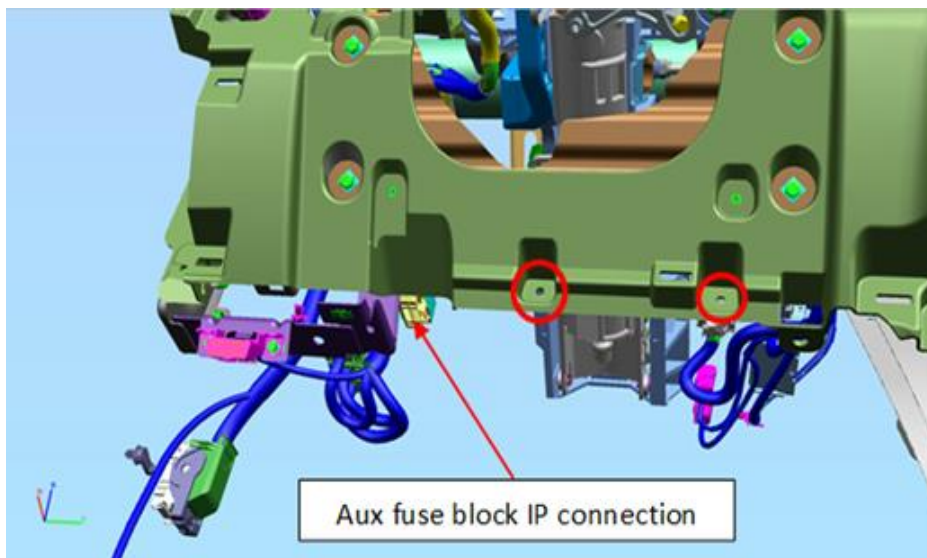

2. Route the 16-pin switch bank connector through the opening in the Instrument Panel as shown in figure 5

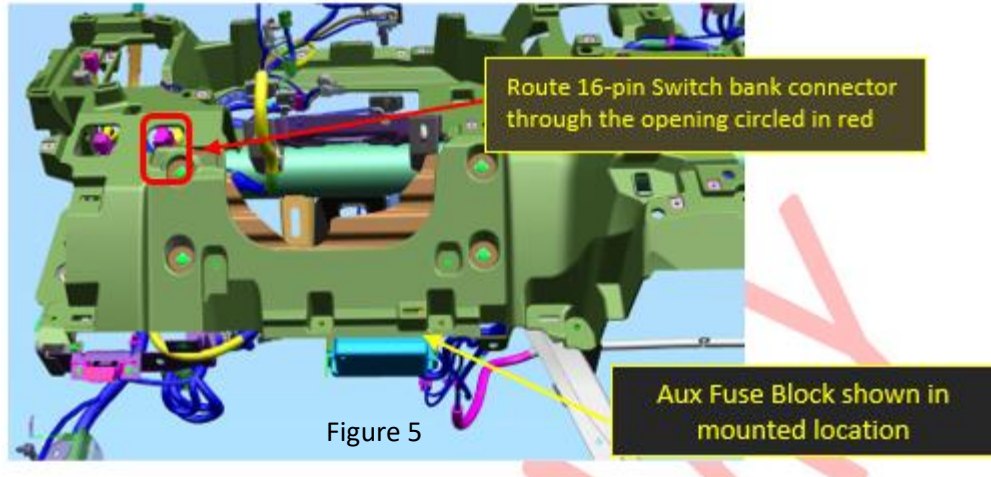

Figure 5

With switches installed into the new knee bolster trim in the provided cut-out. Connect the switch connector/harness and any other electrical connections – Installed knee bolster and reassemble the removed components per the GM service procedure used to remove the knee bolster.

[Instrument Panel Knee Bolster Replacement/Reinstallation Procedure](#)

Install Procedure #2 = Chevrolet LT (GG0/GF3), LT TB (GF4), RST (GFC), ZR2 (GRZ), LTZ (GF9), HC (GFD) and GMC SLE (GFI), Elevation (GFS/GFJ), SLT (GFU)

Color/Console(D07)	Jet Black (-D07)	VY DK ATMOS* (-D07)	Jet Black (&D07)	VY DK ATMOS* (&D07)
Lower IP Trim Panel	87863276	87863278	87863270	87863272
Switch Bank	85080555	85080555	85080555	85080555
Fuse Kit	84669070	84669070	84669070	84669070
Fasteners (2)	11589015	11589015	11589015	11589015
Aux Fuse Block + Switch Harness	86812139	86812139	86812139	86812139
Under Hood Wiring harness	84794790	84794790	84794790	84794790

*VY DK ATMOS= Very Dark Atmosphere Interior color.

1. Remove the Knee Bolster trim panel using the procedure in the link below

[Instrument Panel Knee Bolster Replacement Non 1WT or 1CX trims](#)

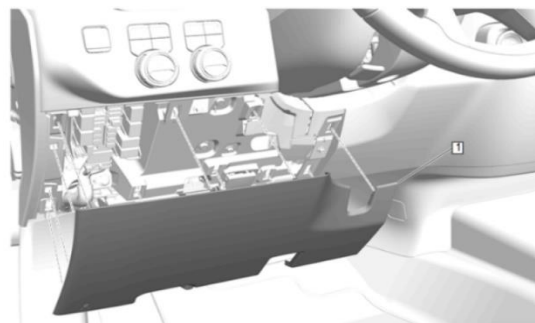

General Motors Upfitter Integration

<http://www.gmupfitter.com>

2. Remove the Instrument Panel Lower Trim Panel using the procedure outlined in the link below. Select the procedure based on if the vehicle is equipped with or without console.

[Lower Trim Panel Replacement w/o console \(-D07\)](#)

[Lower Trim Panel Replacement w/o console \(&D07\)](#)

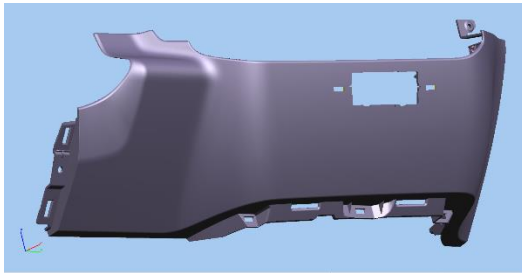

Lower Trim Panel without console (-D07)



Lower Trim Panel with console (&D07)

3. Using the listed fasteners, install the Aux Electrical Center using the mounting holes locations shown in the figure above.
4. Install switches (if not already installed from the factory) in the lower trim panel extension (using new trim panel if adding the 9L7 option) as shown in the figures below

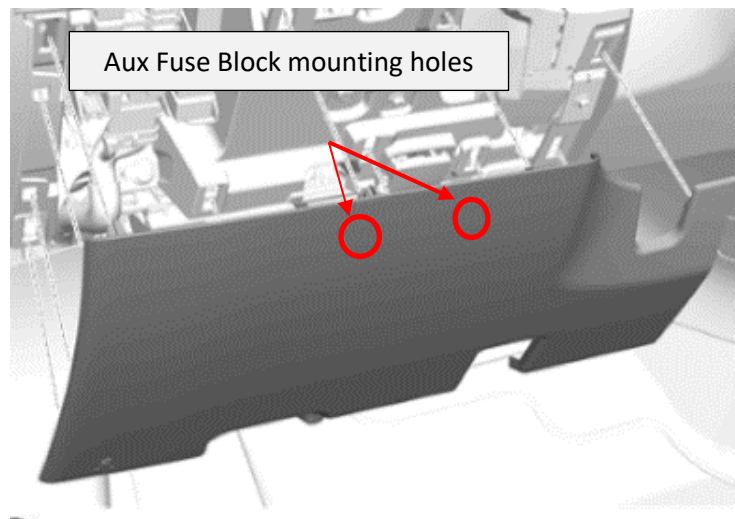

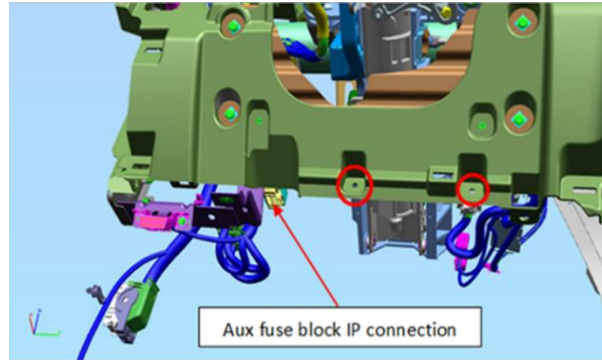

5. Connect 16-cavity connector from Aux Electrical Center to switch assembly
6. (re) Install the lower trim panel with switches.
7. Connect the 14-cavity connector from the Aux Electrical Center to the provisional connector (X213) located under the IP left of the steering column (figure below)
8. Install the provided connector body onto the power wire harness routed earlier from under-hood into the passenger compartment and connect to the Aux Electrical Center mating connector.
9. Reinstall the Knee Bolster trim panel
[Instrument Panel Knee Bolster Replacement Non 1WT or 1CX trims](#)

Adding Fuse Kit:

1. Once all “kit” components have been installed, the Aux Fuse Block can now be powered, for detailed instructions on adding the fuses to the battery mounted electrical center refer to the latest revision of UI Bulletin #147. (<http://www.gmupfitter.com/pages/technical-bulletins>)
2. Following the installation of the fuse kit to the battery mounted electrical center, connect it side stud.

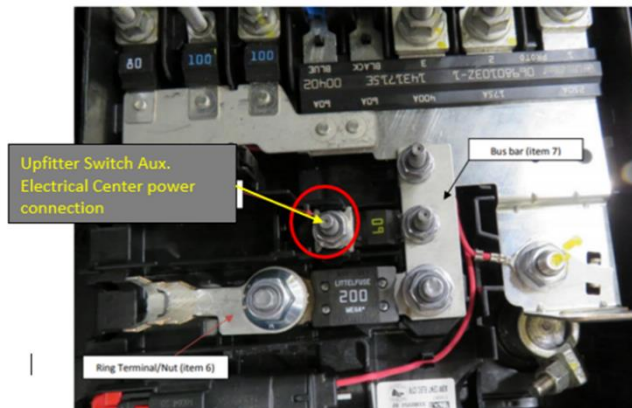

General Motors Upfitter Integration
<http://www.gmupfitter.com>

Upfitter Provisions - 1 of 2 (9L7)

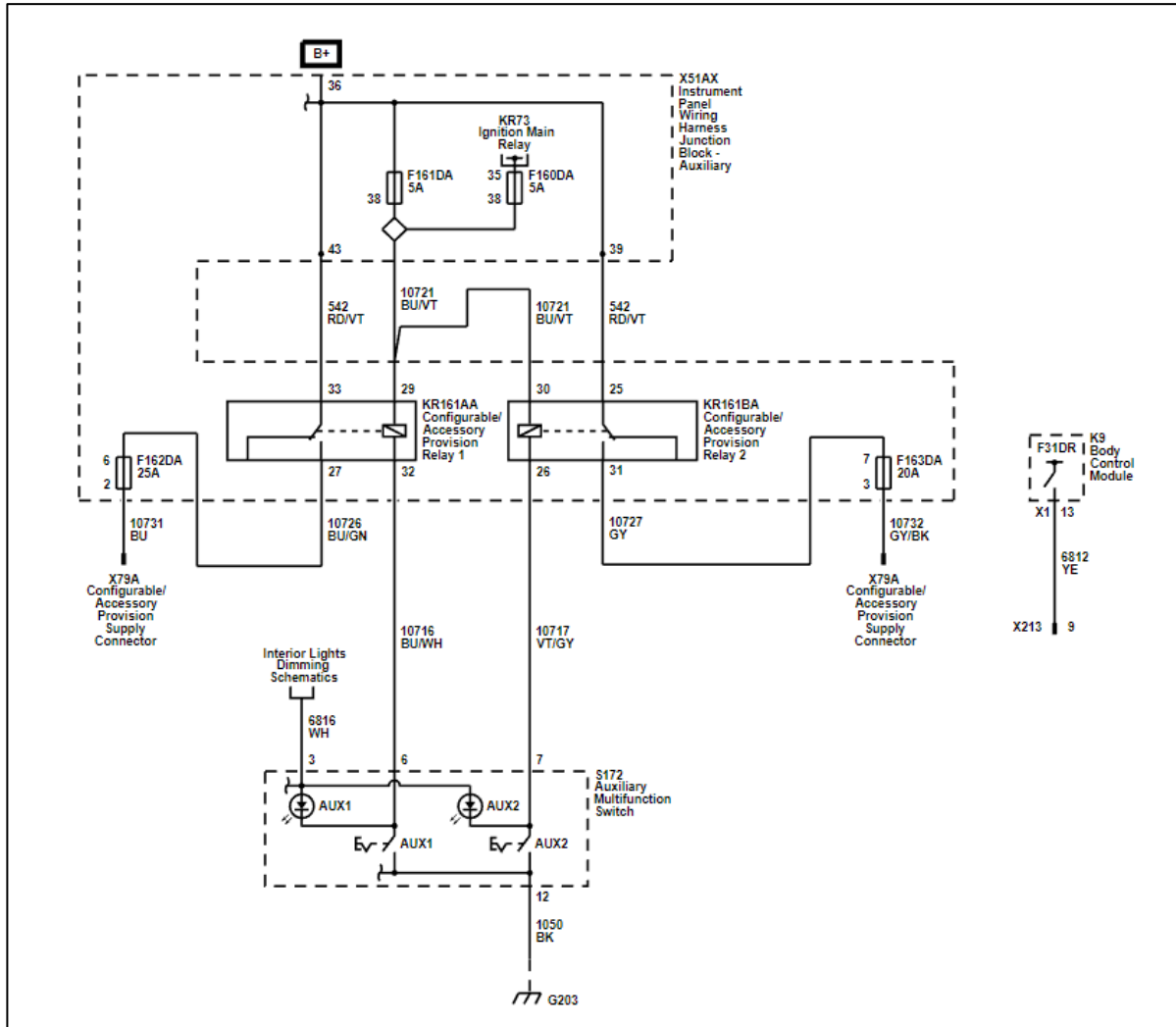



Upfitter Provisions - 2 of 2 (9L7)

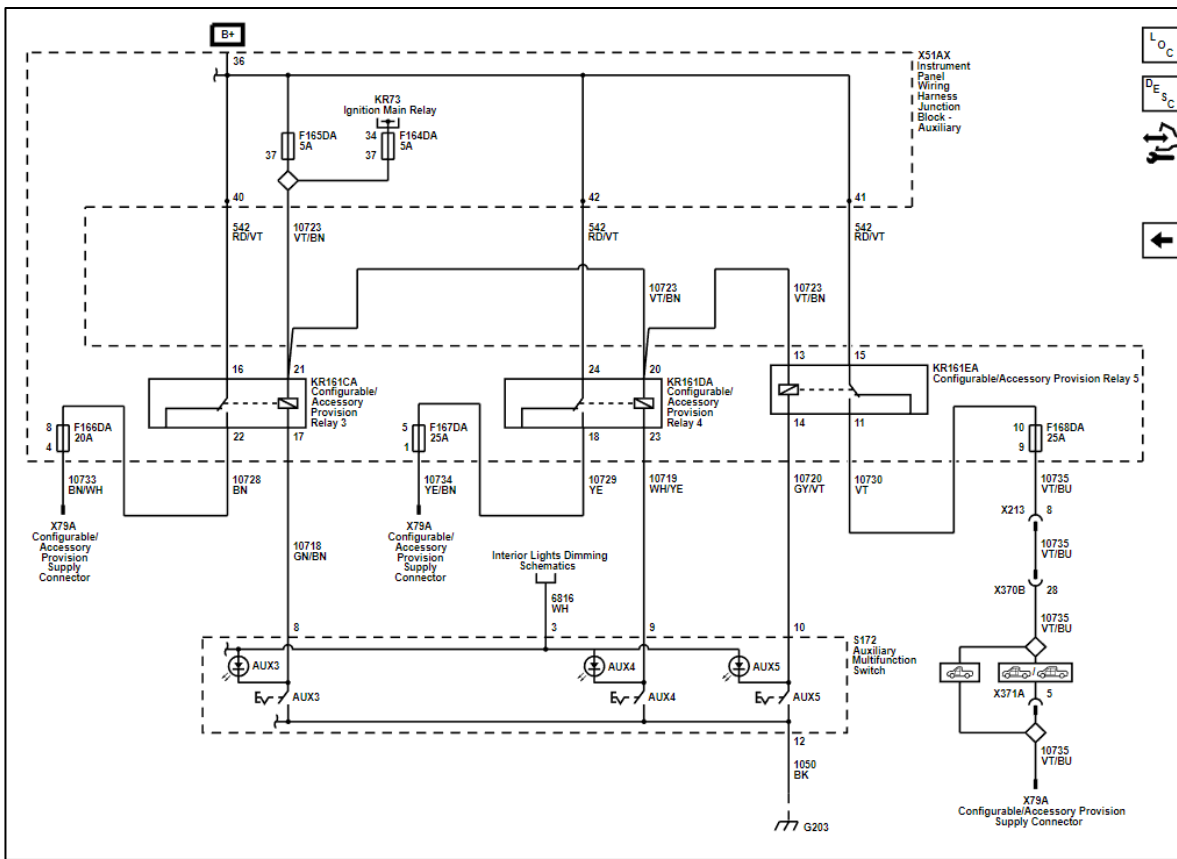

X213 Auxiliary Instrument Panel Harness to Instrument Panel Harness

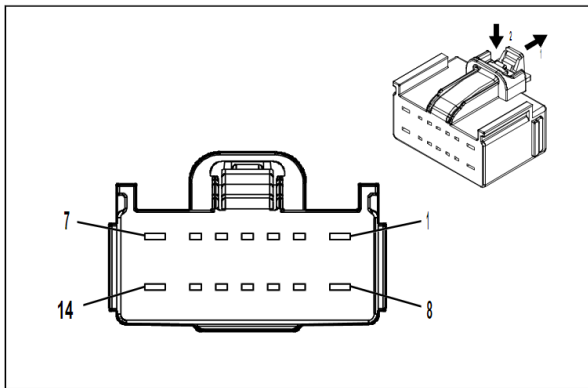

Connector Part Information

Harness Type: Auxiliary Fuse Block Wiring Harness
 OEM Connector: 33366376
 Service Connector: Service by Harness - See Part Catalog
 Description: 14-Way F 1.5, 2.8 YESC Series(GY)

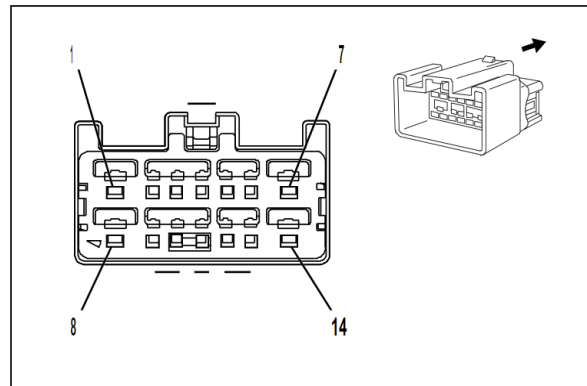

Connector Part Information

Harness Type: Instrument Panel Wiring Harness
 OEM Connector: 10846900
 Service Connector: 88956523
 Description: 14-Way M 1.5, 2.8 YESC Series(L-GY)

Terminal Part Information

Terminal Type ID	Terminated Lead	Diagnostic Test Probe	Terminal Removal Tool
I	Not required	J-35616-2A (GY)	No Tool Required
II	Not required	J-35616-4A (PU)	No Tool Required
III	13578907	J-35616-3 (GY)	J-38125-215A
IV	13578908	J-35616-5 (PU)	J-38125-11A

X213 Auxiliary Fuse Block Wiring Harness to Instrument Panel Wiring Harness (9L7)

Pin	Size	Color	Circuit	Terminal Type ID	Option	Function	Pin	Size	Color	Circuit	Terminal Type ID	Option
1	0.75	BK / WH	851	II	—	Signal Ground	1	2.5	BK	1050	IV	—
2	—	—	—	—	—	Not Occupied	2	—	—	—	—	—
3	0.35	YE	6817	I	—	LED Backlight Dimming Control 1	3	0.35	YE	6817	III	—
4	—	—	—	—	—	Not Occupied	4	—	—	—	—	—
5	0.5	WH / BU	3691	I	—	Trailer Brake Apply Signal	5	0.35	WH / BU	3691	III	—
6	—	—	—	—	—	Not Occupied	6	—	—	—	—	—
7	2.5	RD / BN	4142	II	—	Primary Fused Battery Positive Voltage	7	2.5	RD / BN	4142	IV	—
8	2.5	VT / BU	10735	II	—	Upfitter Accessory 5 Supply Voltage	8	2.5	VT / BU	10735	IV	—
9	—	—	—	—	—	Out of Park Signal	9	0.35	YE	6812	III	—
10	—	—	—	—	—	Vehicle Speed Signal	10	0.35	GN / GY	817	III	—
11	0.35	WH	6816	I	—	Indicator Dimming Control	11	0.35	WH	6816	III	—
12	—	—	—	—	—	Not Occupied	12	—	—	—	—	—
13	0.5	VT / BK	339	I	—	Run/Crank Ignition 1 Voltage	13	0.5	VT / BK	339	III	—
14	2	BU	47	II	—	Trailer Auxiliary Control	14	2	BU	47	IV	—

Additional Information:

The upfitter switches are defaulted to being battery powered but can be reconfigured in pairs to operate only when in accessory/ignition ON by relocating one or two fuses as shown below.

