

MEDIUM DUTY GENERAL INFORMATION (CHEVROLET & GMC, C & T SERIES) (ISUZU, F SERIES)

PROCEDURE FOR HANDLING CHASSIS/DEALER CLAIMS	1
General	1
Shipments Received from Truckaway or Driveaway Company	1
If Received from Railroad	1
Filing a Claim	2
Disposition of Damaged Parts	2
GOVERNMENT REGULATIONS	2
Introduction	2
Responsibility for Complete Vehicle Performance	2
Noise Emission Standards for Transportation Equipment – Medium and Heavy Trucks	3
40 CFR Part 205	3
METHOD OF CERTIFICATION	4
Incomplete Vehicles	4
VEHICLE CLASSIFICATION AND GM APPLICATION	5
FEDERAL REGULATIONS – TIRES	6
GM FLEET & COMMERCIAL OPERATIONS	7
WEIGHTS AND MEASURES	8
Standard Weights and Measures	8
Metric Weights and Measures	9
Equivalent Weights and Measures	9
Decimal Equivalents of Parts of an Inch	10
Approximate Weight of Materials	11
METRIC/U.S. CUSTOMARY CONVERSION TABLE	20
CENTER OF GRAVITY CALCULATIONS	21
Center of Gravity (CG) Definition and Discussion	21
Actual CG Calculation: Chassis, Body and Payload	21

MEDIUM DUTY GENERAL INFORMATION (CHEVROLET & GMC, C & T SERIES) (ISUZU, F SERIES)

BODY MOUNTING INFORMATION	24
Bodies with Wood or Metal Sill Construction (Stake, Platform and Some Types of Van Bodies)	24
Torsionally Rigid Bodies (Tank Bodies and Some Types of Van Bodies)	27
Dump Bodies	28
Fifth Wheel Mounting	29
GENERAL INSTRUCTIONS	See General Instructions Section
FAMILY 2	See Family 2 Section
FAMILY 3	See Family 3 Section

PROCEDURE FOR HANDLING CHASSIS/DEALER CLAIMS

General

All chassis tendered for delivery by the Transportation Company are to be accepted by the Body Company. If a chassis has been damaged or is short certain parts when received by the Body Company, they will repair or replace missing parts, if possible, with their own or other local facilities and promptly forward the claim to the dealer.

If the Body Company or other local facilities are not adequate for replacing missing or damaged parts, the Body Company will promptly notify the Dealer and hold damaged chassis awaiting his instructions. The Dealer must be notified promptly upon receipt of a chassis on which a claim is in order giving the "model," "engine number," and "serial number" and what the damage or shortage consisted of. This is important since Chevrolet/GMC Truck cannot accept claims from the Dealer unless filed within thirty days from date of delivery or unless, within the thirty-day period, the Dealer has advised Chevrolet/GMC Truck that a claim will be filed. Delivery to the Body Company constitutes delivery to the Dealer, since the Body Company is the Dealer's agent.

Completed vehicles that are to be driven to the Dealer or the Dealer's customer must first be serviced by the Body Company at the Body Company's location in accordance with Chevrolet/GMC Truck new vehicle conditioning procedures. Expenses incurred for this condition are the responsibility of the selling Dealer.

Shipments Received from Truckaway or Driveaway Company

The Body Company will inspect condition of chassis and call driver's attention to damage or missing parts and make a detailed notation of both copies of Transportation Company's delivery receipt of the nature and extent of the existing damage and/or shortage and have driver sign such notation on the Dealer's copy. If chassis are received after business hours and cannot, therefore, be adequately inspected, the delivery receipt (both copies) is to carry notation "Received subject to inspection" and show the time and date. On such chassis, a detailed inspection must be made within 24 hours or on the first working day after receipt of chassis and immediately furnish to the Dealer. Any exceptions are to be noted on both copies of the delivery receipt by the Body Company.

If Received from Railroad

Freight car should be opened and contents inspected in presence of railroad representative before starting to unload, and any existing damage or shortage recorded by the railroad representative on his standard inspection report. Body Company must secure from railroad agent, a copy of his inspection report detailing nature and extent of the damage and/or shortage.

If the railroad representative does not comply with consignee's request to make an inspection, then the Body Company will immediately confirm his request (in writing) to the railroad agent, outlining the nature and extent of damage and/or shortage disclosed by consignee's inspection, prior to starting any unloading operations, sending a copy of his letter to the Dealer.

(Procedures continued on next page)

(Procedures continued from previous page)

Filing a Claim

Upon completion of repairs or replacements of missing parts, the Body Company will promptly bill the Dealer for the cost involved, supporting such debit with a detailed statement showing how the amount is arrived at and either the original delivery receipt with notation if received from a truckaway company or the carrier's inspection report if received from a railroad.

Disposition of Damaged Parts

Damaged parts removed from chassis by the Body Company must be held for disposition orders from the Dealer.

Dealer claims will not be allowed unless above instructions are fully complied with.

GOVERNMENT REGULATIONS

Introduction

The Federal Government has established Motor Vehicle Safety Standards for various categories of motor vehicles and motor vehicle equipment under the provisions of the National Traffic and Motor Vehicle Safety Act of 1966. The Act imposes important legal responsibilities on manufacturers, dealers, body builders and others engaged in the manufacturing and marketing of motor vehicles and motor vehicle equipment.

Questions dealing with the specific application of the Act or the standards to your business should be discussed with your legal counsel. This is particularly so because the standards and other requirements or interpretations are subject to change by the government agency in charge, the National Highway Traffic Safety Administration.

New standards and amendments issued by the National Highway Traffic Safety Administration will appear in the Federal Register from time to time. You may obtain the Federal Register, through the Superintendent of Documents, U.S. Government Printing Office, Washington, D.C. 20402.

Responsibility for Complete Vehicle Performance

General Motors performs extensive testing on all trucks described in this book. Major changes to a complete vehicle or the installation of a body on an incomplete truck chassis will, however, affect vehicle performance.

(Government Regulations continued on next page)

MEDIUM DUTY GENERAL INFORMATION (CHEVROLET & GMC, C & T SERIES) (ISUZU, F SERIES)

(Government Regulations continued from previous page)

It is the responsibility of the body and equipment manufacturers to validate final completed vehicle performance. Total vehicle system performance tests may be required. The test schedule must reflect the type of vehicle system loading to which the completed vehicle will be subjected, and must also include consideration of all aspects of performance, e.g., durability, ride, handling, etc.

Noise Emission Standards for Transportation Equipment – Medium and Heavy Trucks

40 CFR Part 205

The U.S. Environmental Protection Agency (EPA) has established noise emission standards applicable to vehicles (in general vehicles in excess of 10,000 pounds GVWR capable of transportation of property on a street or highway) manufactured after January 1, 1978, under the provisions of the Noise Control Act of 1972. The standards provide that vehicles manufactured after January 1, 1978, when tested pursuant to EPA's prescribed test procedure, must conform to an 83 dBA level and vehicles manufactured after January 1, 1988 must conform to an 80 dBA level.

The Act and the standards impose legal obligations on vehicle manufacturers and subsequent manufacturers. Questions dealing with what is covered under the definition of a "vehicle" in the standards and the specific application of the Act or the standards to your business should be discussed with your legal counsel. This is particularly so in light of EPA's broad definition of a "vehicle."

The standards or interpretations of such standards are subject to change by EPA. New standards or amendments issued by the Environmental Protection Agency appear in the Federal Register from time to time. You may obtain the Federal Register through the Superintendent of Documents, U.S. Government Building Office, Washington, D.C. 20402.

NOTE: Model and option weight information is available in the GM Medium Duty Data Book. Contact your local GM dealer for assistance.

METHOD OF CERTIFICATION

Incomplete Vehicles

Will have a label affixed to the Document for Incomplete Vehicles. This is placed in a clear container and shipped with the incomplete vehicle from the factory.

**DOCUMENT
FOR
INCOMPLETE VEHICLE**

**PLACE
LABEL
HERE**

This document is furnished as required by government regulation to aid intermediate and final stage manufacturers in determining conformity to applicable Federal Motor Vehicle Safety Standards. Also included are instructions which must be followed in order to assure that Environmental Protection Agency (EPA) and California emission certification requirements and NHTSA Fuel Economy Regulations are met. As a result of certifying Heavy Duty Vehicles with GVW's up to 10,000 pounds by Federal Light Duty Emission Standards, Part II of this document – U.S. EPA and California Exhaust & Evaporative Emission Requirements and NHTSA Fuel Economy Regulations—has been significantly revised and should be reviewed. This document is not a substitute for knowledge and understanding of the requirements of these standards and regulations. Intermediate and final stage manufacturers should be familiar with all Federal Motor Vehicle Safety Standards and Emission Regulations to be aware of their specific responsibilities as manufacturers.

Any manufacturer making material alterations to this incomplete vehicle during the process of manufacturing the complete vehicle should be constantly vigilant to recognize all the effects, either direct or indirect, on other components, assemblies or systems caused by each such alteration. No alteration should be made to the incomplete vehicle which either directly or indirectly results in any component, assembly or system being in nonconformance with any applicable Federal Motor Vehicle Safety Standard or Emission Regulation.

CANADA MOTOR VEHICLE SAFETY STANDARDS

The following statement, which is required by Section 6.(4) (a) of the Canada Motor Vehicle Safety Regulations is applicable only to incomplete vehicles manufactured in or imported to Canada:

THIS INCOMPLETE VEHICLE CONFORMS TO THE APPLICABLE CANADA MOTOR VEHICLE SAFETY STANDARDS IN EFFECT ON THE DATE OF ITS MANUFACTURE SHOWN ABOVE. THE STANDARDS TO WHICH THIS INCOMPLETE VEHICLE CONFORMS IN FULL ARE DESIGNATED IN THE LIST OF FEDERAL MOTOR VEHICLE SAFETY STANDARDS ON PAGE 3 BY AN ASTERISK (*) IN THE COLUMN FOR THE BASIC TYPE OF INCOMPLETE VEHICLE.



Printed in U.S.A. □ □

MEDIUM DUTY GENERAL INFORMATION (CHEVROLET & GMC, C & T SERIES) (ISUZU, F SERIES)

VEHICLE CLASSIFICATION AND GM APPLICATION

Model	Application	Vehicle Classification	
		MPV	Truck**
W3S042	All models		X
W4S042	All models		X
W5R042	All models		X
(C6H-C7H)042	All models		X
C7H064	All models		X
(F6B-F7B)042	All models		X
F7B064	All models		X

* MPV is a vehicle with 2 or 3 rows of seats.

^ MPV Classification may apply only when unit is completed as a Recreation Vehicle (Camper).

** It is assumed that Cab and Chassis only will be completed as a truck. Chassis only with RPO B3D or B3M will be completed into a school bus.

FEDERAL REGULATIONS – TIRES

The National Highway Traffic Safety Administration has issued regulations dealing with tire identification and record keeping which became effective May 22, 1971. Under these regulations important legal responsibilities are imposed upon tire manufacturers, brand name owners, retreaders, distributors and dealers, and motor vehicle manufacturers and dealers, to maintain and/or report certain information concerning tires. This information will be used to facilitate interest of safety. If you have any questions concerning the application of these regulations to your business, we suggest you consult with your attorney.

In order for GM to meet its responsibility under these tire regulations we have a record of the tires on each vehicle we shipped to you. If you do not change a tire on a GM vehicle, it is important that you make sure that it is reshipped with the same tires that were on it when the vehicle was received by you. This will mean that any tires which you remove from a vehicle during the course of your work should be put back on the same vehicle.

If you do change a tire on a GM vehicle, it is necessary that you furnish us with such information on vehicles which are returned to us after you have completed your work. It is important that you report to us the full tire identification number (TIN) for each tire you install and the full vehicle identification number (VIN) of the vehicle on which the tire is installed.

If you change a tire on a GM vehicle which is not returned to us, you may be responsible for maintaining records of the vehicle identification number (VIN) and the vehicle owner to allow notification, through your records, if tire problems are found.

In case you should receive a defect notification from a tire manufacturer concerning tires which you installed on a vehicle returned to us, you may forward it to us so that we can send it to the vehicle owner whose name will appear on our records.

GM FLEET & COMMERCIAL OPERATIONS

NOTE: For general customer assistance, please call the following Toll-Free Phone numbers or go to the Web Sites listed below:

Chevrolet and GMC Truck Business Center Toll-Free Phone Number:

1-800-862-4389 (prompt #3)

ISUZU Commercial Trucks Toll-Free Phone Number:

1-866-441-9638

Web sites:

www.gmfleet.com

Chevrolet: www.chevrolet.com

GMC: www.gmc.com

Isuzu: www.isuzucv.com

WEIGHTS AND MEASURES

Standard Weights and Measures		
Length		
12 inches	=	1 foot
3 feet	=	1 yard
5 1/2 yards	=	16 1/2 feet
	=	1 rod
1760 yards	=	5820 feet
	=	1 mile
Area		
144 square inches	=	1 square foot
9 square feet	=	1 square yard
30 1/2 sq. yards	=	1 square rod
160 sq. rods	=	43,560 sq. feet or 1 acre
640 acres	=	27,878,400 sq. feet or 1 sq. mile
1 circular inch	=	Area of circle 1 in diameter
1 square inch	=	1.2732 circular inches
Volume		
1728 cubic inches	=	1 cubic foot
27 cubic feet	=	1 cubic yard
1 cord wood	=	128 cubic feet. One cord is 8 feet long, 4 feet wide and 4 feet high
1 board foot	=	144 cubic inches or volume of board 1 foot square and 1 inch thick
1 cylindrical inch	=	Volume of cylinder 1 inch in diameter and 1 inch long or 0.7854 cubic inch
1 cubic inch	=	1.2732 cylindrical inches

Liquid or Fluid Measures		
4 gills (16 fluid ounces)	=	1 pint
2 pints	=	1 quart
4 quarts	=	1 gallon
31 11/32 gallons	=	1 barrel (there is no standard liquid 'barrel')
1 U.S. gallon	=	231 cubic inches or 0.13373 cubic feet
7.4805 gallons	=	1 cubic foot
When water is at its maximum density, 1 cubic foot weighs 62.428 pounds and 1 gallon weighs 8.345 pounds. For approximations, 1 cubic foot of water equals 7 1/2 gallons.		
Dry Measure		
2 pints	=	1 quart
8 quarts	=	1 peck
4 pecks	=	1 bushel
1 U.S. bushel	=	2150.42 cubic inches
	=	1.2445 cubic feet
1 cubic yard	=	21.7 U.S. bushels (approximate)
Measures of Angles or Arcs		
60 seconds (")	=	1 minute (')
60 minutes (')	=	1 degree (°)
90 degrees (°)	=	1 right angle or quadrant
360 degrees (°)	=	1 circle
Avoirdupois Weight (U.S.)		
437.5 grains (16 drams)	=	1 ounce
16 ounces	=	1 pound
100 pounds	=	1 hundred weight

MEDIUM DUTY GENERAL INFORMATION (CHEVROLET & GMC, C & T SERIES) (ISUZU, F SERIES)

2000 pounds	=	1 ton
2240 pounds	=	1 long ton

1000 kilograms (kg.)	=	1 ton (metric)
1000 cubic centimeters (cu. cm.)	=	1 cubic decimeter
1000 cubic decimeters (cu. dm.)	=	1 cubic meter

Metric Weights and Measures		
Length		
10 millimeters (mm.)	=	1 centimeter
10 centimeters (cm.)	=	1 decimeter
10 decimeters (dm.)	=	100 centimeters
	=	1 meter
1000 meters (m.)	=	1 kilometer (km.)
Area		
100 square millimeters (sq. mm.)	=	1 square centimeter
100 square centimeter (sq. cm.)	=	1 square decimeter
100 square decimeters (sq. dm.)	=	1 square meter
Volume		
1000 cubic millimeters (cu. mm.)	=	1 cubic centimeter
1000 cubic centimeters (cu. cm.)	=	1 cubic decimeter
1000 cubic decimeters (cu. dm.)	=	1 cubic meter
Capacity		
10 milliliters (ml.)	=	1 centiliter
10 centiliters (cl.)	=	1 deciliter
10 deciliters (dl.)	=	100 centiliter or 1 liter
1000 liters (l.)	=	1 kiloliter
Weight		
10 milligrams (mg.)	=	1 centigram
10 centigrams (cg.)	=	1 decigram
10 decigrams (dg.)	=	100 centigrams or 1 gram
1000 grams (g.)	=	1 kilogram

Equivalent Weights and Measures		
Length		
1 inch	=	2.54 centimeters
1 foot	=	30.48 centimeters
1 yard	=	0.9144 meters
1 mile	=	1.609 kilometers
1 centimeter	=	0.3937 inches
1 meter	=	39.37 inches or 3.281 feet
1 kilometer	=	0.6214 mile or 1093.3 yards
Area		
1 square inch	=	6.452 square centimeters
1 square foot	=	0.093 square meters
1 square yard	=	0.836 square meters
1 acre	=	4047 square meters
1 square mile	=	2.59 square kilometers
1 square centimeter	=	0.155 square inches
1 square meter	=	10.76 square feet
1 square kilometer	=	0.3861 square miles
Volume		
1 cubic inch	=	16.39 cubic centimeters
1 cubic foot	=	0.0283 cubic meters
1 cubic yard	=	0.7646 cubic meters
1 (U.S.) gallon	=	3.785 liters
1 cubic centimeter	=	0.061 cubic inches

MEDIUM DUTY GENERAL INFORMATION (CHEVROLET & GMC, C & T SERIES) (ISUZU, F SERIES)

1 cubic meter	=	35.31 cubic feet
1 liter	=	61.02 cubic inches or 0.2642 gallons
Weight		
1 ounce	=	28.35 grams
1 pound	=	0.4536 kilograms
1 ton	=	907.2 kilograms
1 gram	=	15.43 grains
1 kilogram	=	2.205 pounds
1 metric ton	=	2205 pounds

Decimal Equivalents of Parts of an Inch			
1/64	0.015625	33/64	0.515625
1/32	0.03125	17/32	0.53125
3/64	0.046875	35/64	0.546875
1/16	0.0625	9/16	0.5625
5/64	0.078125	37/64	0.578125
3/32	0.09375	19/32	0.59375
7/64	0.109375	39/64	0.609375
1/8	0.125	5/8	0.625
9/64	0.140625	41/64	0.640625
5/32	0.15625	21/32	0.65626
11/64	0.171875	43/64	0.671875
3/16	0.1875	11/16	0.6875
13/64	0.203125	45/64	0.703125
7/32	0.21875	23/32	0.71875
15/64	0.234375	47/64	0.734375
1/4	0.25	3/4	0.75
17/64	0.265625	49/64	0.765625

9/32	0.28125	25/32	0.781255
19/64	0.296875	51/64	0.796875
5/16	0.3125	13/16	0.8125
21/64	0.328125	53/64	0.828125
11/32	0.34375	27/32	0.84375
23/64	0.359375	55/64	0.859375
3/8	0.375	7/8	0.875
25/64	0.390625	57/64	0.890625
13/32	0.40625	29/32	0.90625
27/64	0.421875	59/64	0.921875
7/16	0.4375	15/16	0.9375
29/64	0.453125	61/64	0.953125
15/32	0.46875	31/32	0.96875
31/64	0.484375	63/64	0.984375
1/2	0.5	1	1.0

MEDIUM DUTY GENERAL INFORMATION (CHEVROLET & GMC, C & T SERIES) (ISUZU, F SERIES)

Approximate Weight of Materials		
Most materials and commodities vary in weight and containers vary in shape and size. Therefore it is impossible to list any but average weights per cubic foot or per unit of measurement and the following weights should be used only for approximation purposes. When it is necessary to figure weights accurately for recommendation of truck or tractor-trailer equipment, exact weights and dimensions should be obtained from local sources. This is particularly true of fruits and vegetables, containers for which vary widely in type, size and shape according to commodity and locality.		
Building Supplies, other than lumber and stone		
	Pounds per	
	Cu. Ft.	Cu. Yd.
Asbestos	153	4130
Asphalt		
Brick	125	3375
Lumps	85	2300
Paving	100	2700
Cinders	50	1350
Clay (dry lumps)	85	2300
Wet lumps	110	2970
Wet packed	135	3650
Fire	125	3375
Concrete		
Cinder or slag	120	3250
Gravel or stone	150	4050
Ave. wet mix	138	3730
Crushed stone, ave.	100	2700
Earth (loam), Loose	76	2050
Shaken	87	2350
Packed	95	2565
Moist	100	2700
Wet	125	3375
Gravel, Dry	95	2565
Wet	125	3375

	Pounds per	
	Cu. Ft.	Cu. Yd.
Motor-lime	110	2970
Rubble-dry	138	3730
Wet	154	4160
Pitch	70	1900
Plaster of Paris (gypsum)	150	4050
Quicklime, Solid	95	2550
Ground-loose	55	1485
Shaken	75	2030
Rock crushed, ave.	100	2700
Sand, Fine-dry	110	2970
Wet	125	3735
Course-dry	95	2565
Wet	120	3240
Tar	65	1755
Terra Cotta	110	2970
Tile, Solid	115	3100
Construction	40	1080
Brick		Thousand
Soft, 2.5 x 4 x 8.25		4320
Common, 2.25 x 4 x 8.25		5400
Hard, 2.25 x 4.25 x 8.5		6480
Pressed, 2.375 x 4 x 8.375		7500
Paving, 2.5 x 4 x 8.5		6750
Paving block, 3.5 x 4.5 x 8.5		8750
Fire, 2.5 x 4.5 x 9		7000
Cement block		
8 x 8 x 16	42	each
8 x 12 x 16	58	each
Cinder block		
8 x 8 x 16	35	each
8 x 12 x 16	45	each

MEDIUM DUTY GENERAL INFORMATION (CHEVROLET & GMC, C & T SERIES) (ISUZU, F SERIES)

	Pounds per	
	Cu. Ft.	Cu. Yd.
Glass Common window Plate, 1/4" thick	162 3.3	cu. ft. sq. ft.
Lime Small barrel Large barrel	210 320	barrel barrel
Farm and Dairy Products, except Fruits and Vegetables		
	Pounds	Per
Alfalfa seed	60	bushel
Barley	48	bushel
Bran	20	bushel
Buckwheat	49	bushel
Butter, 15 dia. x 15 15 dia. x 15 10.25 x 8.75 x 10.5 (30 lb.) bricks 9 lb. pail	25 70 32 10	tub tub case each
Calf, Live (avg.)	150	head
Cheese, 15 dia. x 5.25 15 dia. x 7.5 15 dia. x 15	25 35 70	box box box
Chickens Live broilers (20 avg.) Fowl (12 avg.) Std. crate, empty 24 x 35 x 13	58 78 18	crate crate each
Clover seed	60	bushel
Corn, Ear Shelled Sweet corn (green)	35 56 43	bushel bushel bushel

	Pounds	Per
Corn Meal	44	bushel
Cotton Gin bale, 20 x 48 x 54 Std. bale, 24 x 28 x 56 Comp bale, 20 x 24 x 56	515 515 515	each each each
Cotton seed	32	bushel
Cow, Live, Feeder (avg.) Butcher (avg.) Heavy steer (avg.)	600 800 1000	head head head
Eggs, 30 doz. 12 x 12 x 26	55	crate
Flax seed	56	bushel
Flour, 19 1/8 head, 30 stave	215	barrel
Hay, Baled 17 x 22 x 40 14 x 16 x 43	60 85	bale bale
Hemp seed	44	bushel
Hog, Live (avg.)	235	head
Horse, Live (avg.)	1350	head
Ice Cream 2.5 gal., 9 dia. x 11 5 gal., 9 dia. x 21	18 35	can can
Lamb, Live (avg.)	80	head
Malt, Barley Rye Brewer's grain	28 32 40	bushel bushel bushel
Millet	50	bushel
Oats	32	bushel
Popcorn, Ear Shelled	35 56	bushel bushel

MEDIUM DUTY GENERAL INFORMATION (CHEVROLET & GMC, C & T SERIES) (ISUZU, F SERIES)

	Pounds	Per
Rice, Unhulled	43	bushel
Rye	56	bushel
Sheep, Live (avg.)	138	each
Shorts	20	bushel
Soy beans	60	bushel
Straw, Baled 17 x 22 x 40	45	bale
Tallow	60	cu. ft.
Timothy seed	45	bushel
Vetch seed	60	bushel
Wheat, Bulk	60	bushel
Bag	90	1.5 bushel
Wool, Pressed	82	cu. ft.

Fruits, Vegetables and Nuts (in bulk, unless container specified)		
	Size Container	Lbs. Per Bushel or Container
Apples, Fresh	bushel	48
Western box	11.5 x 12 x 20	50
New England box	11.25 x 14.25 x 17.5	56
Standard barrel	17hc. 28.5 stone	160
Apricots, Fresh	bushel	48
Western box	5.5 x 12 x 20	23
Artichokes, Box	10 x 11.5 x 22	44
Asparagus, Pr. Crate	11.5 high 19.375 long,	
Loose	9.75 wide top,	38
Bunches	11 bottom	31
Avocados, Box	5.75 x 11.25 x 17.5	16

	Size Container	Lbs. Per Bushel or Container
Bananas, Carton	4.25 x 14.25 x 30	38
Single stem	bunch	55
Beans, Dry castor	bushel	46
White	bushel	60
Lima	bushel	56
Fresh lima	bushel	39
String	bushel	36
(Hamper) string	5 peck	45
Beets (avg.)	bushel	55
Small crate	9.75 x 13.25 x 24	50
Western crate	14 x 19 x 24.5	95
Berries, Crate 24 pt.	9.75 x 9.75 x 20	25
24 qt.	11.75 x 11.75 x 24	48
32 at.	15.5 x 11.75 x 24	63
Broccoli, Bushel Crate	12.75 x 12.75 x 17	30
Brussels sprouts, Crate	7.75 x 10.75 x 21.375	26
Cabbage, Hamper	1.5 bushel	58
Crate	12.75 x 18.5 x 19	60
Western crate	14 x 19 x 24.5	85
Bbl. crate	12.75 x 18.75 x 37.375	110
Cantaloupe, Crate		
Pony	11.75 x 11.75 x 23.5	58
Standard	12.75 x 12.75 x 23.5	68
Jumbo	13.75 x 13.75 x 23.5	78
Pony flat	4.75 x 12.75 x 23.5	26
Standard flat	5.25 x 14.25 x 23.5	28
Jumbo flat	5.75 x 15.25 x 23.5	32
Carrots, Topped	bushel	55
With tops	bushel	40
Crate	11.75 x 14.125 x 24	60

MEDIUM DUTY GENERAL INFORMATION (CHEVROLET & GMC, C & T SERIES) (ISUZU, F SERIES)

	Size Container	Lbs. Per Bushel or Container
Cauliflower	bushel	30
Crate	9.375 x 19 x 24	50
Celery, Std. Crate	11.625 x 22 x 22.625	70
1/2 crate	10.75 x 13 x 20.375	35
Northern crate	16.5 x 21.25 x 22	85
Cherries, Unstemmed	bushel	56
Stemmed	bushel	64
Lug box	5.625 x 11.875 x 19.75	17
Chestnuts	bushel	50
Cranberries		
1/4 bbl. box	9.5 x 11 x 14	28
1/2 bbl. box	12.5 x 14.75 x 22	60
Cucumbers	bushel	55
Crate	9.75 x 13.75 x 24	75
Case	5 x 13.25 x 19	26
Eggplant, Hamper	bushel	40
Crate	14 x 11.75 x 24	54
Endive, Basket	bushel	25
Hamper	1.5 bushel	36
Grapefruit, Western box	11.5 x 11.5 x 24	68
Southern box	12.75 x 12.75 x 27	90
Grapes, Basket	bushel	48
Lug box	5.375 x 16.375 x 17.5	30
Western box	15.5 x dia. x 14	45
Basket	12 quarts	18
Greens	bushel	25
Hickory nuts	bushel	45
Horseradish roots	bushel	35
Kale	bushel	25

	Size Container	Lbs. Per Bushel or Container
Lemons, Limes, Western box	10 x 13 x 25	80
Southern box	12.75 x 12.75 x 27	90
Lentils	bushel	60
Lettuce, Hamper	bushel	25
Hamper	1.5 bushel	38
Basket	8.5 x 11.75 x 21.375	17
Crate	13.75 x 17.5 x 24.5	75
1/2 crate	9.5 x 13.5 x 24.5	40
Okra, Hamper	.5 bushel	18
Hamper	bushel	34
Onions, Dry, Basket	bushel	55
Bag	17 x 32	50
Crate	20.5 x 11.5 x 10.5	58
Green with tops	bushel	32
Oranges, Western box	11.5 x 11.5 x 24	80
Southern box	12.75 x 12.75 x 27	90
Bushel box	10.75 x 10.75 x 23.5	65
Parsley, Bushel Crate	12.75 x 12.75 x 17	30
Parsnips	bushel	48
Peaches, Basket	bushel	48
Basket	.5 bushel	25
Crate	10.5 x 11.25 x 24	50
Western box	5.5 x 11.25 x 24	22
Peanuts, Unshelled	bushel	22
Bag		100
Pears, Basket	bushel	50
Western box	9.625 x 12.125 x 19.75	51
Peas, Dry	bushel	60
Fresh hamper	bushel	35
Hamper	40 quarts	45

MEDIUM DUTY GENERAL INFORMATION (CHEVROLET & GMC, C & T SERIES) (ISUZU, F SERIES)

	Size Container	Lbs. Per Bushel or Container
Pecans, Large bag		100
Small bag		50
Peppers, Basket	bushel	25
Crate	14.125 x 11.75 x 24	45
Pineapples, Crate	11 x 12.5 x 36	85
Plums, Basket	bushel	56
Western box	5.625 x 16.375 x 17.5	25
Potatoes, Sweet	bushel	55
White or Irish	bushel	60
Bag	1 2/3 bushel	102
Barrel	barrel	185
Prunes, Box	5.625 x 16.375 x 17.5	25
Quinces	bushel	50
Radishes, Basket	bushel	34
Crate	9.75 x 13.75 x 24	40
Rhubarb, Box	5.125 x 11.5 x 22	24
Romaine, Crate	13.875 x 18.875 x 24.5	64
Crate	12.25 x 13 x 15.25	27
Rutabagas	bushel	56
Spinach	bushel	27
Squash	bushel	46
Sweet Corn, Basket	bushel	45
Crate	13 x 13 x 24	60
Tomatoes, Basket	bushel	55
Lug box	7.25 x 14 x 17.5	35
Crate	10.5 x 11.25 x 24	48
Basket	8.5 x 8.75 x 20	18
Turnips	bushel	54

	Size Container	Lbs. Per Bushel or Container
Walnuts, Bulk	bushel	50
Bag		100

Liquids		
	Pounds per	
	Cu. Ft.	Gallon
Acetone	50	6.6
Alcohol, commercial	51	6.8
Asphalt, hot oil	71	9.5
Carbolic acid	60	8.0
Castor oil	61	8.1
Chloroform	95	12.7
Coconut oil	58	7.8
Corn oil	58	7.8
Corn syrup	86	11.5
Cotton seed oil	58	7.8
Cream	64	8.5
Creosote	69	9.2
Crude oil	56	7.5
Ether	46	6.2
Fuel oil-Diesel	52	7.0
Fuel oil-Furnace	56	7.5
Gasoline	45	6.0
Glycerine	79	10.5
Honey	90	12.0
Kerosene	50	6.6

MEDIUM DUTY GENERAL INFORMATION (CHEVROLET & GMC, C & T SERIES) (ISUZU, F SERIES)

	Pounds per	
	Cu. Ft.	Gallon
Linseed oil	59	7.9
Lubricating	52	7.0
Maple syrup	82	11.0
Milk, bulk	64	8.6
Molasses	90	12.0
Muriatic acid, 40%	40	10.0
Naphtha, petroleum	42	5.6
Nitric acid, 91%	94	12.5
Olive oil	58	7.7
Peanut oil	57	7.6
Petroleum	56	7.5
Sorghum syrup	86	11.5
Soybean oil	58	7.7
Sugar cane syrup	85	11.3
Sulfuric acid, 87%	112	15.0
Turpentine	54	7.3
Vinegar	64	8.5
Water, fresh	63	8.4

	Size Container	Lbs. Per Container
Beer, Wood barrel	.25 barrel	
Steel barrel	.25 barrel	
Wood barrel	.25 barrel	
Steel barrel	.25 barrel	
Carton, 24 12oz.		
Regular bottles	17.25 x 11.5 x 9.875	
Steinie bottles	18.375 x 12.125 x 7.375	

	Size Container	Lbs. Per Container
Tin cans	16.25 x 11 x 5.125	
Wood case, 24 12oz.		
Regular bottles	21 x 13.5 x 10	
Steinie bottles	22 x 13.75 x 7.5	
Note: Beer cases are of many types with variable size and weight. Cases shown are average for popular full depth type with partitions.		
	Size Container	Lbs. Per Container
Milk, 5 gal. can	10.25 dia. x 19	62
10 gal. can	13 dia. x 23	115
Crate, 21.5 pt. bottles		33
20 pt. bottles		54
12 qt. bottles		64
Note: Milk bottle crates vary widely in dimensions and weights. Those shown are average weights.		
	Size Container	Lbs. Per Container
Molasses, 50 gal. bbl.	20.25 hd. 34 stave	675
	Size Container	Lbs. Per Container
Soft drinks		
Half depth bottle box		
24, 6 to 8 oz. bottles	12.25 x 18.75 x 8.5	39
Full depth bottle box		
12, 24 to 32 oz. bottles	13.375 x 18.5 x 12.25	60

MEDIUM DUTY GENERAL INFORMATION (CHEVROLET & GMC, C & T SERIES) (ISUZU, F SERIES)

Lumber, Air Dried		
Kiln dried lumber averages 10% to 15% lighter, and green lumber 40% to 50% heavier than air dried.		
	Pounds per	
	Cu. Ft.	Thousand Board Ft.
Ash, Black or Red	40	3330
White	46	3830
Bamboo	22	
Basswood	30	2500
Beech	30	2500
Birch	48	4000
Butternut	30	2500
Cedar	30	2500
Cherry	44	3670
Chestnut	37	3080
Cottonwood	37	3080
Cypress	30	2500
Elm, Soft	38	3170
Rock	45	3750
Fir, Douglas	32	2670
Eastern	25	2080
Gum	40	3330
Hemlock	29	2420
Hickory	54	4500
Locust	42	3500
Mahogany	42	3500
Maple, Hard	44	3670
Soft	34	2830

	Pounds per	
	Cu. Ft.	Thousand Board Ft.
Oak, Black	42	3500
Red	42	3500
White	48	4080
Pine, Long Leaf	44	3670
North Carolina	36	3000
Oregon	32	2670
Red	30	2500
White	26	2170
Yellow, Northern	34	2830
Southern	45	3750
Short leaf	38	3170
Long leaf	44	3670
Poplar	27	2250
Redwood	30	2500
Spruce	28	2330
Sycamore	37	3080
Walnut	43	3580
Willow	31	2580
Lath, Standard length 29 in. Put up in bundles of 50. Avg. bundle; dia. 9 in., weight 25 lbs.		
Shingles, Bundles contains the equivalent of 250 shingles, measures 24 x 20 x 10, avg. weight 50 lbs.		

Metals, Minerals, Ores, Rock, Stone, Coal		
	Pounds Per	
	Cu. Ft.	Cu. Yd.
Alabaster, gypseous	160	4320
Aluminum, pure	165	4450

MEDIUM DUTY GENERAL INFORMATION (CHEVROLET & GMC, C & T SERIES) (ISUZU, F SERIES)

	Pounds Per	
	Cu. Ft.	Cu. Yd.
Andesita stone	180	4850
Antimony	420	11650
Asbestos	153	4130
Babbit	440	11900
Barytes, mineral	280	7560
Basalt rock	185	5000
Bauxite	160	4320
Bluestone	120	3240
Borax	110	2970
Brass, Cast	525	14175
Rolled	534	14420
Drawn	542	14635
Bronze	550	14850
Chalk	137	3700
Charcoal, oak	33	890
pine	23	620
Coal, broken		
Anthracite	60	1600
Bituminous	45	1200
Pocahontas	50	1350
Cannel	50	1350
Coke	27	730
Copper, Cast	550	14850
Rolled	560	15120
Diabase	185	5000
Dolomite	181	4890
Emery	250	6750
Feldspar	160	4320

	Pounds Per	
	Cu. Ft.	Cu. Yd.
Flint	185	5000
Gneiss, Solid	160	4320
Crushed	95	2565
Granite, Solid	175	4725
Crushed	96	2590
Graphite	170	4590
Greenstone, Solid	187	5050
Crushed	107	2900
Gypsum	150	4050
Iron, Cast	450	12150
Wrought	485	13100
Hornblende	187	5050
Lead, Cast	710	19170
Limestone, Solid	166	4480
Crushed	95	2565
Magnesite	187	5050
Manganese	475	12825
Marble, Solid	165	4455
Crushed	95	2565
Marl	140	3800
Mercury	850	
Mica	185	5000
Nickel	537	14500
Ore: Most ores are 15% to 20% heavier than the rock which forms the bulk of the ore.		
Peat	50	1350
Phosphate rock	200	5400
Porcelain	150	4050

MEDIUM DUTY GENERAL INFORMATION (CHEVROLET & GMC, C & T SERIES) (ISUZU, F SERIES)

	Pounds Per	
	Cu. Ft.	Cu. Yd.
Porphyry	172	4645
Pumice	40	1080
Pyrites	315	8500
Quartz	165	4455
Rip-rap stone	65	1750
Salt, Rock, Solid	136	3670
Very coarse	35	950
Coarse	45	1215
Fine	50	1350
Barrel	280	per bbl.
Salt peter	69	1860
Sandstone, Solid	147	3970
Crushed	86	2325
Shale, Solid	172	4645
Crushed	92	2485
Silica	135	3650
Slag, Solid	175	4750
Crushed	75	2025
Screenings	100	2700
Slate	175	4725
Soapstone	169	4565
Steel, Cast	490	13250
Rolled	495	13365
Stone, Crushed, avg.	100	2700
Sulphur	125	3375
Talc	170	4600
Tin	460	12400
Trap rock	187	5050

	Pounds Per	
	Cu. Ft.	Cu. Yd.
Zinc	440	11880
Miscellaneous		
	Pounds Per	
	Cu. Ft.	Cu. Yd.
Ashes, cool (packed)	45	1215
Bone	115	3110
Cork	15	405
Furniture	6	160
Garbage		
Dry, paper wrapped	15-30	400-800
Wet	50	1240
Groceries, misc.	30	810
Ice	57	1540
Paper, Solid, avg.	58	1565
Rubber goods	94	2540
Snow, moist-packed	50	1350
Street sweepings	32	865

METRIC/U.S. CUSTOMARY CONVERSION TABLE

	Multiply	By	To Get/Multiply	By	To Get
Linear	inches inches feet	x 25.4 x 2.54 x 0.3048	millimeters (mm) centimeters (cm) meters (m)	x 0.03937 x 0.3937 x 3.281	inches inches feet
Area	square inches square inches square feet	x 645.16 x 6.452 x 0.0929	square millimeters (sq. mm) square centimeters (sq. cm) square meters (sq. m)	x 0.00155 x 0.155 x 10.764	square inches square inches square feet
Volume	cubic inches cubic inches cubic inches quarts gallons cubic feet cubic feet fluid oz.	x 16387.0 x 16.387 x 0.01639 x 0.94635 x 3.7854 x 28.317 x 0.02832 x 29.57	cubic millimeters (cu. mm) cubic centimeters (cu. cm) liters (l) liters (l) liters (l) liters (l) cubic meters (cu. m) milliliters (ml)	x 0.000061 x 0.06102 x 61.024 x 1.0567 x 0.2642 x 0.03531 x 35.315 x 0.03381	cubic inches cubic inches cubic inches quarts gallons cubic feet cubic feet fluid oz.
Mass	ounces (av) pounds (av) tons (2000 lb) tons (2000 lb)	x 28.35 x 0.4536 x 907.18 x 0.90718	grams (g) kilograms (kg) kilograms (kg) tonne (t)	x 0.03527 x 2.2046 x 0.001102 x 1.1023	ounces (av) pounds (av) tons (2000 lb) tons (2000 lb)
Fuel Economy	miles/gal gal/mile gal/mile	x 0.42514 x 2.3522 x 235.22	kilometers/liters (km/l) liters/kilometer (l/km) liters/100 kilometers (l/100 km)	x 2.3522 x 0.42514 x 0.004251	miles/gal gal/mile gal/mile
Power	horsepower ft.-lb./min	x 0.746 x 0.0226	kilowatts (kW) watts (W)	x 1.34 x 44.25	horsepower ft.-lb./min
Torque	pound-inches pound-feet	x 0.11298 x 1.3558	newton-meters (N-m) newton-meters (N-m)	x 8.851 x 0.7376	pound-inches pound-feet
Velocity	miles/hour kilometers/hour miles/hour	x 1.6093 x 0.27778 x 0.4470	kilometers/hour (km/h) meters/sec (m/s) meters/sec (m/s)	x 0.6214 x 3.600 x 2.237	miles/hour kilometers/hour miles/hour

Common Metric Prefixes

mega (M) = 1,000,000
kilo (k) = 1,000

centi (c) = 0.01
milli (m) = 0.001

hecto (h) = 100
micro (μ) = 0.000001

U.S. Imperial Gallon Comparison

1 U.S. Gallon = 0.833 Imperial Gallon
1 Imperial Gallon = 1.201 U.S. Gallon

CENTER OF GRAVITY CALCULATIONS

A. Center of Gravity (CG) Definition and Discussion

Vertical center of gravity (CG) is a criteria used to evaluate the weight transfer of a vehicle. In simple terms, the center of gravity (CG) of an object is a straight line which divides the object's weight, half above the line and half below the line. Obviously, the higher the load is stacked, the higher its CG will be.

For our discussion, we must define two terms:

1. Vehicle "Maximum Vertical CG" is the allowable center of gravity which the vehicle is designed to accommodate.
2. "Actual CG" is the combined center of gravity for the chassis, body and payload required.

The Maximum Vertical CG of the vehicle is the maximum CG height which can be utilized for the completed vehicle, including payload. For Tandem rear axle vehicles, this is a maximum of 75 in. from the ground and for Single rear axles a 70 in. maximum from the ground. For all vehicles, the wheelbase to CG height ratio is 0.45. The maximum vertical CG of a vehicle is printed on the Incomplete Vehicle Document (IVD) cover label.

NOTE: If the actual CG exceeds the 75 in. Tandem axle model or 70 in. Single axle model, please contact the Sales Engineering Department for assistance.

If the vehicle ordered is changed after the order confirmation is received, maximum vertical CG may be affected. In all cases, the CG imprinted on the IVD is the maximum vertical CG.

B. Actual CG Calculation: Chassis, Body and Payload

Once the maximum vertical CG is known, it is a relatively simple matter to determine if a particular body and payload will stay within the CG criteria.

(Center of Gravity continued on next page)

MEDIUM DUTY GENERAL INFORMATION (CHEVROLET & GMC, C & T SERIES) (ISUZU, F SERIES)

(Center of Gravity continued from previous page)

In order to determine the actual CG of the chassis, body and payload, each component's CG must be known. The chassis CG for each model is at the top of the unladen frame rail. This figure is conservative, so variances due to optional suspensions, rear axles and tires need not be taken into account. The firm supplying the body will be able to provide the CG dimension of this body, measured from the top of the frame rail. The customer, in conjunction with the Body Builder, can discuss the loading characteristics of the payload and determine the CG of the payload itself.

Since all CG heights must be measured from the ground, it is necessary to add the loaded frame height to any CG figure measured from the top of the rail.

Once the CG of the chassis, body and payload are known, the combination actual CG is determined by the following formula:

For calculation purposes, the vehicle should be loaded to rated GVWR (if possible). If the CG obtained by the following formula is lower than the maximum vertical CG at GVWR, the vehicle will meet the requirements. If the actual CG at GVWR is higher than the maximum, the vehicle is unsatisfactory as specified and some change must be made before ordering the trucks. Changes which affect the maximum vertical CG of the truck are GVWR and wheelbase.

$$\begin{array}{rcl} & (\text{Weight} \times \text{CG}) & \dots \text{ Chassis} \\ + & (\text{Weight} \times \text{CG}) & \dots \text{ Body} \\ + & \underline{(\text{Weight} \times \text{CG})} & \dots \text{ Payload} \\ = & \text{Total} & \text{Chassis} + \text{Body} + \text{Payload} \\ , & \underline{(\text{Weight})} & \text{GVWR} \\ = & \text{Total} & \text{Actual CG Height} \end{array}$$

Let's now look at a number of examples which will demonstrate the proper method of checking orders. For our first example, let's use a C7H042 with a van box to haul assorted groceries.

Recall that in order to figure the actual CG of the completed vehicle we need to know the weight and CG of the chassis, the body and the payload. The chassis was found to weigh 7,400 lbs. after all options had been added, and the CG (unloaded from weight) was 37.35 in. A Van box that is 14.5 feet would give perfect weight distribution, and according to the body manufacturer, the Van body weighs 2,000 lbs. and has a CG of 28 in. above the frame or 65.35 in. from the ground. When fully loaded, the payload would weigh 18,100 lbs. and have a CG of 44.3 from the top of the frame rail, 81.65 in. from the ground. Remember that the manner in which the load is distributed in the body must be obtained from the user, so as to properly determine the payload CG.

(Center of Gravity continued on next page)

MEDIUM DUTY GENERAL INFORMATION (CHEVROLET & GMC, C & T SERIES) (ISUZU, F SERIES)

(Center of Gravity continued from previous page)

Taking the three major components into consideration, we are now ready to determine the actual CG. The numbers are as follows:

	Weight	CG
Chassis	7,400 lbs.	37.35 in.
Body	2,000 lbs.	65.35 in.
Payload	18,100 lbs.	81.65 in.

The equation now looks like this:

$$\begin{array}{rcl} & (7,400 \times 37.35) & \dots \text{ Chassis} \\ + & (2,000 \times 65.35) & \dots \text{ Body} \\ + & \underline{(18,100 \times 81.65)} & \dots \text{ Payload} \\ = & \text{Total} & \text{Chassis + Body + Payload} \\ , & \underline{\text{(Weight)}} & \text{GVWR} \\ = & \text{Total} & \text{Actual CG Height} \end{array}$$

It was shown that this model has a maximum vertical CG of 70 in. The actual CG was found to be 68.54 in., a figure lower than the 70 in. allowed; therefore, the body and payload combination is acceptable.

BODY MOUNTING INFORMATION

The methods and practices of body mounting are typical and of importance to prevent frame side rail or body damage caused by unevenly distributed stresses and strains due to load and chassis movement.

Proper body mounting and/or vehicle specifications can also be critical to maintaining vehicle ride and handling characteristics.

Bodies with Wood or Metal Sill Construction (Stake, Platform and Some Types of Van Bodies)

The following points are important in mounting these torsionally flexible bodies:

1. Sills should rest directly and squarely on frame side rails. Wood sills must be chamfered 0.5 in. (13 mm) at the front end, tapering to meet the frame approximately 12 in. (300 mm) from front end of sill.
2. Sills must not overhang outside of frame. If wood sill is not as wide as frame flange, install spacer blocks at hold-down. Wood grain of blocks should be parallel (up and down) with hold-down.

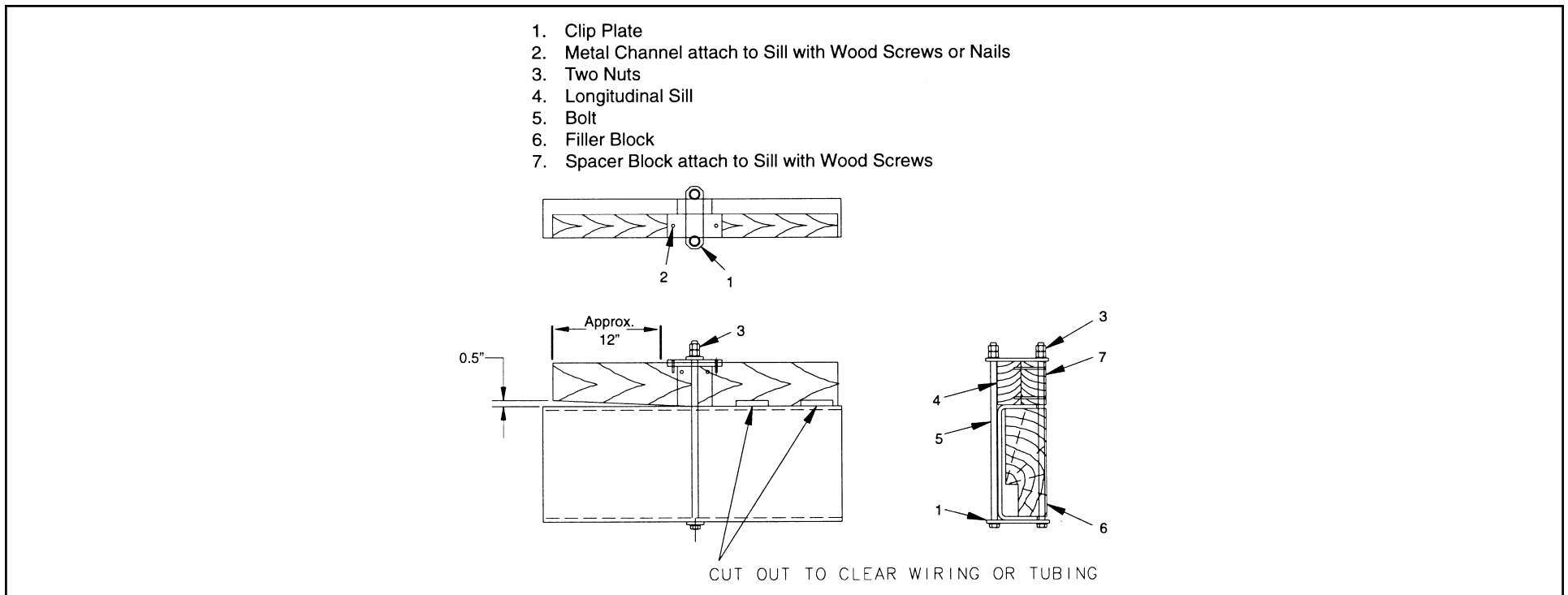

MEDIUM DUTY GENERAL INFORMATION (CHEVROLET & GMC, C & T SERIES) (ISUZU, F SERIES)

(Body Mounting Information continued from previous page)

3. Shear bolts (0.5 in. or 13 mm diameter minimum) must be located near rear of body sills. On bodies with wood sill constructed, upper and lower shear bolt brackets must have a clearance of 0.18-0.25 in. (5-6 mm) before final attachment of shear bolt. On bodies constructed with steel sills, upper shear bolt bracket may be bolted or welded to sill. Clearance between upper and lower brackets to be 0.06-0.12 in. (1.5-3 mm) before final attachment of shear bolt. Optional shear bolt installation is acceptable when steel body sills are used.

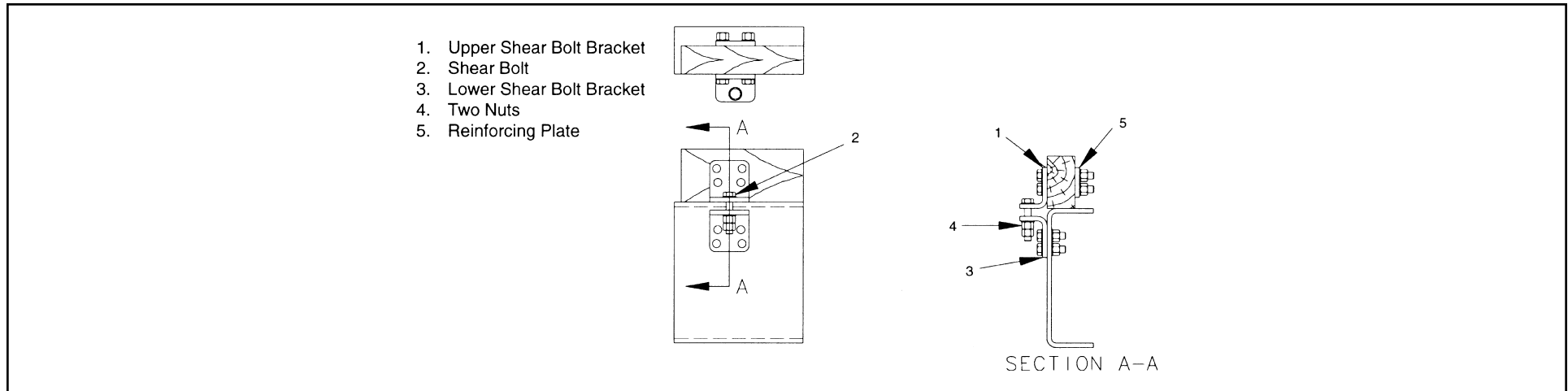

4. Rabbet grooves at top of longitudinal wood sills to permit use of sheet metal channels (1.7 mm or #14 gauge minimum) at each mounting or optional method using 0.25 in. (6 mm) minimum flat plate. Metal channels or flat plate should extend approximately 1 in. (25 mm) beyond clip plate.

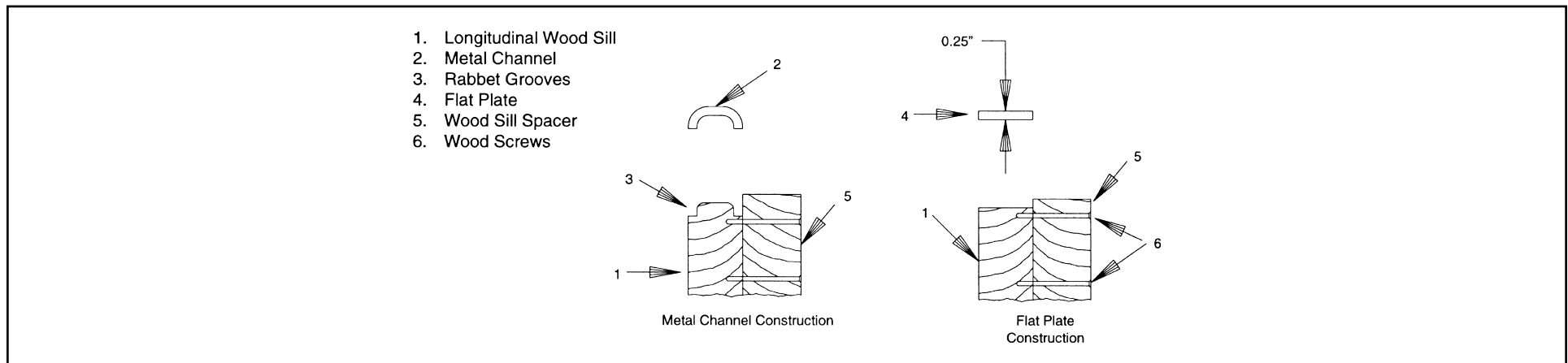

(Body Mounting Information continued on next page)

(Body Mounting Information continued from previous page)

5. On bodies with steel sills, a hardwood spacer not less than 0.75 in. (19 mm) thick (chamfered 0.5 in. (13 mm) at front end and tapering to meet frame 12 in. (300 mm) from front end of spacer) must be used between sill and frame side rail (wood spacer is not necessary if body steel sill has required taper).
6. Mountings must be spaced to clear suspension and any other parts attached to frame side rail. Use two long bolts, studs or "U" bolts 0.5 in. (13 mm) minimum diameter for each mounting. One mounting should be located at the front end of sill (at or as close to rear end of taper as possible), one near rear end of sill and others should be spaced as nearly equal as possible between front and rear mountings. In no instance should frame side rails or crossmembers be mutilated in any way to accommodate mountings.
7. Use clip plates (same thickness as mounting bolt diameter) at top and bottom of mounting bolts. When "U" bolts are used, contour at top of "U" bolt should fit flat against clip plate. Plate may be notched instead of using holes.
8. Use a block of hard, dry wood with grain running up and down between flanges of frame side rail at each mounting. Block should extend beyond width of frame flanges and should be grooved. Mounting bolt fitted into groove will hold block in place. Where steel body sill are used, a similar block is required between sill flanges.
9. Two nuts or one self-locking nut must be used at each threaded end of mounting bolts. **Single nut and lockwasher is not sufficient.** (In optional tapped plate installation, heavy-duty lockwashers must be used under bolt heads.)

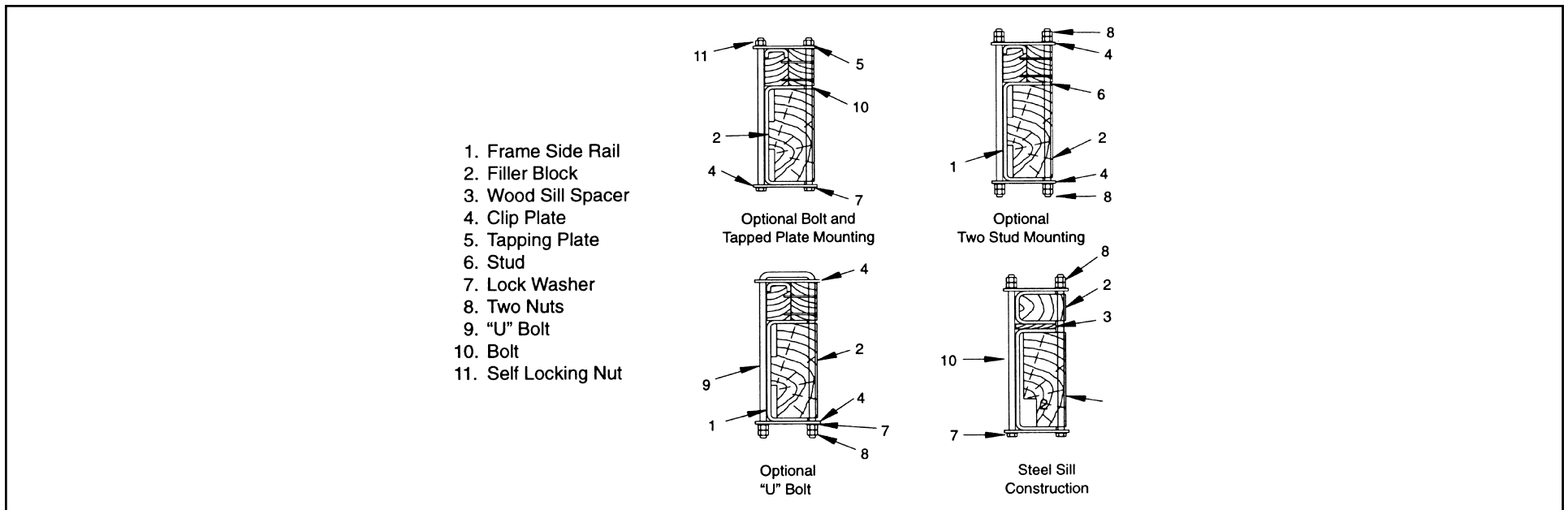

(Body Mounting Information continued on next page)

(Body Mounting Information continued from previous page)

Torsionally Rigid Bodies (Tank Bodies and Some Types of Van Bodies)

Due to solid construction, this type of body requires a more flexible mounting. Spring loading of body mountings provides the optimum frame and body life. For this reason the following principles should be followed in mounting a body of this type:

1. A hardwood spacer, not less than 0.75 in. (19 mm) thick, chamfered 0.5 in. (13 mm) at front end and tapering to meet frame approximately 12 in. (300 mm) from front end of spacer, must be used between body sill and frame side rail. (Wood spacer is not necessary if metal body sill has required taper.)
2. A body guide, ribbed for extra strength, should be bolted or welded to body sill near front end of body. It should extend below body sill and contact wear plate bolted to frame side rail. This guide restricts lateral movement of body and thus relieves shear stress on mountings.
3. Mountings are spring-loaded angle type, as illustrated. These may be bolted or welded to body sill but must be bolted to frame side rail. **No welding must be done directly on frame side rail.** Position mountings to allow a clearance of 0.25-0.31 in. (6-8 mm) between upper and lower brackets. Use SAE Grade 8 English or 10.9 Metric bolts with either self-locking nuts (huglock, flex-lock, shakeproof, elastic or equal) or nuts and heavy-duty lockwashers. Spring-loaded mounting bolts require two nuts if self-locking nut is not used. Springs to be as short as practical to allow pre-loading to prevent excessive "Body Roll" in operation and a minimum of 1-1.5 in. (25-38 mm) at front of body before becoming solid. Trunnion type of body mounting which provides flexibility is acceptable or in place of spring-loaded type.
4. Shear bolts (0.5 in. or 13 mm diameter minimum) must be located near rear of body sills. Clearance between upper and lower shear bolt brackets must be 0.06-0.12 in. (1.5-3 mm) before final attachment of shear bolt.

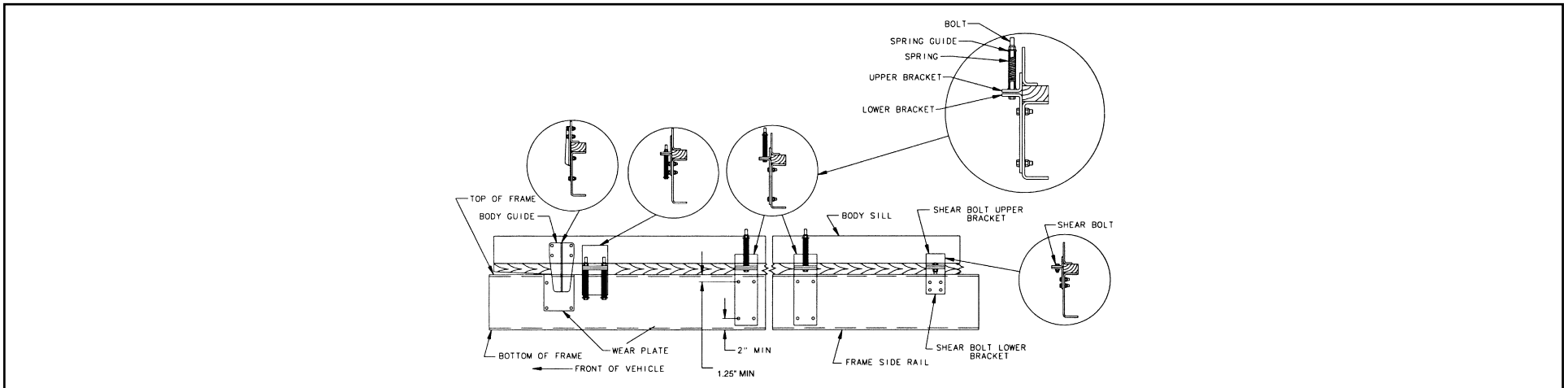

(Body Mounting Information continued on next page)

(Body Mounting Information continued from previous page)

Dump Bodies

The following points are important in Dump Body Mounting:

1. A hardwood spacer not less than 0.75 in. (19 mm) thick, chamfered 0.5 in. (13 mm) at front end and tapering to meet frame approximately 12 in. (300 mm) from front end of spacer, must be used between body sub-frame and frame side rail. Spacer must also be notched to fit over angle fishplate.
2. Weld a small metal angle to body sub-frame near end of taper to hold wood spacer in place.
3. A body guide, ribbed for extra strength, should be bolted or welded to sub-frame near front end of body. It should extend above sub-frame to receive and stabilize front end of dump body, and extend below sub-frame to help control lateral movement of body and thus relieves shear stress on mountings. When chassis is not fishplate equipped, body guide should contact a wear plate bolted to frame side rails.
4. Other mountings are simple angle mounts as illustrated. These may be bolted or welded to body sub-frame but must be bolted to side frame rail. **No welding must be done directly on frame side rail.**
5. Body hinge and rear mounting bracket of body manufacturer's design securely attaches body sub-frame to frame side rail. All mounting brackets to have sufficient clearance before final attachment to insure positive contact of sill to side rail upper flange. This is extremely important since load must be distributed along frame instead of localized on mounting brackets.
6. Use SAE Grade 8 English or 10.9 Metric bolts with either self-locking nuts (huglock, flex-lock, shakeproof, elastic or equal) or nuts and heavy-duty washers for attachment of mounting brackets.

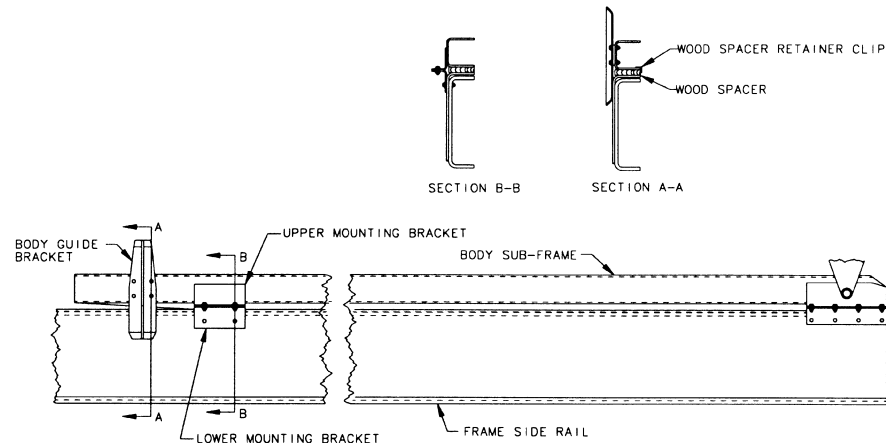

(Body Mounting Information continued on next page)

(Body Mounting Information continued from previous page)

Fifth Wheel Mounting

The proper methods of fifth wheel mounting are essential in minimizing stress concentrations that cause damage to frame rails. Welding fifth wheel mounting brackets to frame side rails and altering crossmembers will void warranty on frames.

“U” bolts are not a recommended method in mounting fifth wheels.

Guidelines for mounting:

1. The mounting bracketry absorbs stress and spreads the trailer load that transfers through the fifth wheel into the frame rails. Angles and other fabricated mountings should extend ahead of the leading edge of the fifth wheel to help accomplish this.
2. Cutouts in the side mounting angles should be held to a minimum. All cutouts that are required should have a generous corner radius 1 in. (25.0 mm) (minimum). A plate mount is recommended for all liquid load applications.
3. Fasteners used to mount the bracketry and fifth wheel should be SAE grade 8 bolts, prevailing torque nuts and a thru-hardened washer against both seats. A minimum of five 0.625 in. (16 mm) diameter bolts should be used per side for attaching the angle bracket to the frame.
4. Positioning of the fifth wheel is determined by axle distribution load requirements and minimum cab/trailer swing clearance for a given tractor trailer combination. The fifth wheel position should be calculated so that the axle loads do not exceed the GAWRs specified by General Motors.
5. Fifth wheel height, from top of frame side rail, is related to fifth wheel location and type of semi-trailer used to obtain desired tire clearance. This height should provide sufficient clearance with the trailer loaded plus allowance for “Body Roll”. At this time, it is recommended that clearance between the landing gear and outer tire be checked with the trailer in a jackknife position, again allowing sufficient clearance for “Body Roll” when performed on uneven terrain.

