

# DOCUMENT FOR INCOMPLETE VEHICLE, APPLICABLE TO THE 2021 MODEL YEAR CADILLAC XT5 B9Q – FUNERAL COACH, OR V4U – LIMOUSINE

General Motors, Renaissance Center  
P.O. Box 300  
Detroit, Michigan 48265-3000  
www.gm.com

**DO NOT REMOVE**  
THIS DOCUMENT MUST REMAIN WITH THIS VEHICLE UNTIL IT  
IS CERTIFIED AS A COMPLETED VEHICLE

## PLACE LABEL HERE

The Label affixed here includes the following information:

- the name of the incomplete vehicle manufacturer;
- the month and year the incomplete vehicle manufacturer performed its last manufacturing operation on the incomplete vehicle;
- the vehicle identification number (VIN);
- the Gross Vehicle Weight Rating (GVWR) expressed in kg (lb), intended for the vehicle when it is a completed vehicle;
- The Gross Axle Weight Rating (GAWR) expressed in kg (lb), intended for each axle of the vehicle when it is a completed vehicle, listed in order from front to rear.

This document is furnished as required by the Canada Motor Vehicle Safety Act and United States (U.S.) Federal Motor Vehicle Safety Regulations (FMVSR) to aid intermediate and final stage manufacturers in their determination of conformity of the completed vehicle with applicable Canada Motor Vehicle Safety Standards (CMVSS) and U.S. Federal Motor Vehicle Safety Standards (FMVSS). Also included are instructions which must be followed in order to assure that Environmental Protection Agency (EPA) and California Air Resources Board (CARB) emission certification requirements, U.S. National Highway Traffic Safety Administration (NHTSA) Fuel Economy Regulations and Environmental Protection Agency (EPA) Greenhouse Gas Regulations are met.

This document is not a substitute for knowledge and understanding of the requirements of the Canada Motor Vehicle Safety Act, Federal Motor Vehicle Safety Regulations (FMVSR), or applicable Canada Motor Vehicle Safety Standards (CMVSS) and Federal Motor Vehicle Safety Standards (FMVSS). Intermediate and final stage manufacturers should be familiar with the Regulations and Standards referred to above to be aware of their specific responsibilities as they relate to the final destination and sale of each incomplete vehicle.

Any intermediate or final stage manufacturer making material alterations to this incomplete vehicle during the process of manufacturing the complete vehicle should be constantly vigilant to recognize all the effects, either direct or indirect, on other components, assemblies or systems caused by any alteration. No alteration should be made to the incomplete vehicle that directly or indirectly results in any component, assembly or system being in nonconformance with any applicable Canada Motor Vehicle Safety Standard or Federal Motor Vehicle Safety Standard or Emission Regulation or Fuel Economy/Greenhouse Gas Regulation.

The statements contained in this Incomplete Vehicle Document are accurate as of the date of manufacture of the Incomplete Vehicle and can be relied on by any intermediate and/or final stage manufacturer as a basis for certification.

## INTRODUCTION

This document contains information relative to conformance of this incomplete vehicle with the following:

- Part I - **FEDERAL MOTOR VEHICLE SAFETY STANDARDS AND CANADA MOTOR VEHICLE SAFETY STANDARDS**
- Part II - **U.S. ENVIRONMENTAL PROTECTION AGENCY, STATE OF CALIFORNIA, AND CANADIAN EMISSION REQUIREMENTS AND NHTSA FUEL ECONOMY REQUIREMENTS**

### PART I

This section contains a list of Canada Motor Vehicle Safety Standards (CMVSS), and Federal Motor Vehicle Safety Standards (FMVSS), followed by a section entitled "Statements Regarding Canada Motor Vehicle Safety Standards (CMVSS), and Federal Motor Vehicle Safety Standards (FMVSS)". In the latter section, an appropriate statement of applicability is made for each standard, and by vehicle type, as it relates to the incomplete vehicle.

The identifiers TYPE 1, TYPE 2 or TYPE 3 prefix the statements (of applicability) regarding Canada Motor Vehicle Safety Standards (CMVSS), and Federal Motor Vehicle Safety Standards (FMVSS). "Examples" of these statements follow:

- TYPE 1** A statement that the vehicle when completed will conform to the standard if no alterations are made in identified components of the incomplete vehicle. **EXAMPLE:** This vehicle when complete will conform to CMVSS 104 and FMVSS No. 104, Windshield Wiping and Washing Systems, if no alterations are made in the windshield wiper components.
- TYPE 2** A statement of specific conditions of final manufacture under which the manufacturer specifies that the completed vehicle will conform to the standard. **EXAMPLE:** This vehicle when completed will conform to CMVSS 121 and FMVSS 121, Air Brake Systems, if it does not exceed any of the gross axle weight ratings, if the center of gravity at GVWR is not higher than ## feet above the ground, and if no alterations are made to any brake system component.
- TYPE 3** A statement that conformity with the standard cannot be determined based upon the components supplied on the incomplete vehicle, and that the incomplete vehicle manufacturer makes no representation to conformity with the standard.

In accordance with the requirements of Canada Motor Vehicle Safety Regulations, and Federal Motor Vehicle Safety Regulations Part 568.4, the following information is included on the label affixed to the front cover of this document:

- the name of the incomplete vehicle manufacturer;
- the month and year the incomplete vehicle manufacturer performed its last manufacturing operation on the incomplete vehicle;
- the vehicle identification number (VIN);
- The Gross Vehicle Weight Rating (GVWR) expressed in kg (lb): The GVWR on the label on the cover of this document is for the incomplete vehicle itself. It is NOT necessarily the maximum GVWR of the completed vehicle. The maximum GVWR of the completed vehicle depends on whether option B9Q or V4U was ordered. The maximum GVWR is shown in the GVWR TABLE that follows. The actual completed vehicle GVWR should be shown on the final stage manufacturer's certification label.
- The Gross Axle Weight Rating (GAWR) expressed in kg (lb): The GAWRs on the label on the cover of this document are for the incomplete vehicle. They are NOT necessarily the maximum GAWRs of the completed vehicle. The maximum GAWRs of the completed vehicle depends on whether B9Q or V4U was ordered. The maximum GAWRs are shown in the GVWR/GAWR TABLE that follows. The actual completed vehicle GVWR/GAWRs should be shown on the final stage manufacturer's certification label.

In addition, the final stage manufacturer is responsible under Canada Motor Vehicle Safety Regulations, and Federal Motor Vehicle Safety Regulations and Part 567.5, to place the GVWR and the GAWR of each axle, on the Final Vehicle Certification Label. Required on the label is the "Gross Vehicle Weight Rating" or "GVWR" followed by the appropriate value in kilograms and (pounds), which shall not be less than the sum of the unloaded vehicle weight, rated cargo load, and 68 kg (150 lb) times the number of the vehicle's designated seating positions, if known. However, for school buses the minimum occupant weight allowance shall be 54.4 kg (120 lb) per passenger and 68 kg (150 lb) for the driver.

Unloaded Vehicle Weight means the weight of a vehicle with maximum capacity of all fluids necessary for operation of the vehicle, but without cargo, occupants or accessories that are ordinarily removed from the vehicle when they are not in use.

During the completion of this vehicle, GVWR and GAWR may be affected in various ways, including but not limited to the following:

- The installation of a body or equipment that exceeds the rated capacities of the Incomplete Vehicle.
- The addition of designated seating positions that exceed the rated capacities of the Incomplete Vehicle.
- Alterations or substitution of any components such as axles, springs, tires, wheels, frames, steering and brake systems that may affect the rated capacities of the Incomplete Vehicle.
- **For options B9Q – Funeral Coach, the incomplete vehicle is to be manufactured into a Truck. Type: Truck**
- **For options V4U – Limousine, the incomplete vehicle is to be manufactured into a Multipurpose Passenger Vehicle. Type: MPV**

**GVWR/GAWR TABLE**

Option	GVWR		GAWR FRT		GAWR RR	
	lb	kg	lb	kg	lb	kg
B9Q	6,001	2,722	2,976	1,350	3,196	1,450
V4U	6,369	2,875	3,196	1,450	3,406	1,545

**PART I – CHART A**

LIST OF CANADA MOTOR VEHICLE SAFETY STANDARDS (CMVSS) AND FEDERAL MOTOR VEHICLE SAFETY STANDARDS (FMVSS), APPLICABLE TO THE CADILLAC XT5 B9Q – FUNERAL COACH OR V4U – LIMOUSINE

**SEE STATEMENTS REGARDING CMVSS AND FMVSS ON PAGES THAT FOLLOW**

CMVSS NO.	FMVSS NO.	TITLE	B9Q Funeral Coach	V4U Limousine
1106	-	Exterior noise	1	1
ICES-002	-	Canada interference causing equipment standard	1	1
101	101	Controls and displays	1	1
102	102	Transmission shift position sequence, starter interlock and transmission braking effect	1	1
103	103	Windshield defrosting and defogging systems	1	1
104	104	Windshield wiping and washing systems	1	1
106	106	Brake hoses, hydraulic, air and vacuum	1	1
108	-	Daytime running lamps	1	1
108	108	Lamps, reflective devices and associated equipment	2,3	2
110	110	Tire selection and rims for motor vehicles with a GVWR of 4536 kg (10,000 lb) or less	2	2
111	111	Rear visibility	1,2,3	1,2,3
113	113	Hood latch system	1	1
114	114	Theft protection and rollaway prevention	1	1
115	-	Vehicle identification number	1	1
116	116	Motor vehicle brake fluids	1	1
118	118	Power operated window, partition and roof panel systems	1	1
124	124	Accelerator control systems	1	1
126	126	Electronic stability control systems	2	2
135	135	Light vehicle brake systems	2	2
-	138	Tire pressure monitoring systems	2	2
201	201	Occupant protection in interior impact	3	3
202	202A	Head restraints	1,3	1,3
203	203	Impact protection for the driver from the steering control system	1	1
204	204	Steering control rearward displacement	1	1
205	205	Glazing materials	1	1
206	206	Door locks and door retention components	3	1
207	207	Seating systems	1,3	1,3
208	208	Occupant crash protection	2,3	2,3
209	209	Seat belt assemblies	1,3	1,3
210	210	Seat belt assembly anchorages	1,3	1,3
210.1	-	Tether anchorages for restraint systems	3	3
210.2	-	Lower universal anchorage systems for restraint systems and booster cushions	3	3
212	212	Windshield mounting	2	2
213.4	213	Built-in child restraint systems and built-in booster cushions	3	3
214	214	Side impact protection	3	3
216	216a	Roof crush resistance	3	3
219	219	Windshield zone intrusion	2	2
220	220	School bus rollover protection	3	3
	225	Child restraint anchorage system	3	3
226	226	Ejection Mitigation	3	3
301	301	Fuel system integrity	3	3
302	302	Flammability of interior materials	1,3	1,3
-	403	Platform Lift Systems	3	3
-	404	Platform Lift Systems Installations in Motor Vehicles	3	3

- TYPE 1, 2 or 3 numbers to the right-hand side of the table above designate the statement TYPE(S) associated with the CMVSS and/or FMVSS standards that follow.

# Statements Regarding Canada Motor Vehicle Safety Standards (CMVSS), and Federal Motor Vehicle Safety Standards (FMVSS)

## CMVSS 1106 – EXTERIOR NOISE

### Applies to all types of Incomplete Vehicles Contained in this Document

**TYPE 1** The following statement is applicable to all types of incomplete vehicles contained in this document (unless otherwise noted on the cover).

- A. This incomplete vehicle, when completed, will conform to the above standard providing no alterations are made which affect the function, physical, chemical, or mechanical properties, environment, location or vital spatial clearances of the components, assemblies or systems, as manufactured by General Motors, including but not limited to those listed below (if equipped):

Air Induction System (tuning elements)	Intake system (Air Induction System (i.e. Air filter, Mass Air flow (MAF) sensor, ducts))
Alternator	Power steering pump
Axles/halfshafts/propshaft	Powertrain control and logic
Components for AWD system (axle, propshaft, PTU)	Powertrain cooling fan and motor assemblies
Engine assembly	Radiator/condenser assembly to body seals
Exhaust System	Tires (including correct tire pressure)
Exterior noise generating devices	Transmission/Transaxle assembly
Exterior rearview mirror assemblies	Underbody shields including air deflector
Front of dash sound deadening material	Wheelhouse liners and shields
Hood assembly including sound deadening material and seals	

- B. Final compliance with CMVSS 1106 is the responsibility of the final stage manufacturer for any modifications, added material, components, or systems.

## INTERFERENCE CAUSING EQUIPMENT STANDARD (CANADA ONLY) – ICES-002

### Applies to all types of Incomplete Vehicles Contained in this Document

**TYPE 1** The following statement is applicable to all types of incomplete vehicles propelled by an internal combustion engine, electrical means or both contained in this document. (unless otherwise noted on the cover).

This incomplete vehicle, when completed, will conform to the performance requirements of the above standard provided no alterations are made which affect the function, physical, chemical, or mechanical properties, environment, location or vital spatial clearances of the components, assemblies or systems, as manufactured by General Motors, including but not limited to those listed below:

Low voltage battery	Charging System
High voltage battery	Ignition system
Electric propulsion system	BCM/SDM

Each vehicle propelled by an internal combustion engine, electrical means or both shall bear a bilingual label that represents the manufacturer's Self-Declaration of Compliance (SDoC) to Innovation, Science and Economic Development Canada ICES-002. This label shall be permanently affixed to the vehicle propelled by an internal combustion engine, electrical means or both or displayed electronically and its text must be clearly legible.

The final stage manufacturer must provide a statement of compliance on the Final Stage Manufacturer's Compliance Label or an additional label with the following bilingual information in order to comply with Industry Canada's Interference Causing Equipment Standard ICES/NMB-002:

ICES/NMB-002

**CMVSS and FMVSS 101 – CONTROLS AND DISPLAYS**  
**Applies to all types of Incomplete Vehicles Contained in this Document**

**TYPE 1** The following statement is applicable to all types of Incomplete Vehicles contained in this document as noted above (unless otherwise noted on the cover).

This incomplete vehicle, when completed, will conform to CMVSS 101 and FMVSS 101 providing no alterations are made which affect the size, location, identification or illumination of the controls and displays or the location, travel and type of driver's seat, as manufactured by General Motors.

The following controls must be operable, and the following displays for the following functions and shall be fitted in such a manner that they are identifiable, by the driver while the driver is seated in the driver's designated seating position with the driver's seat belt fastened around the driver in accordance with the manufacturer's instructions:

Hand operated controls (if equipped):

Automatic vehicle speed (cruise control)	Horn
Clearance lamps (switch)	Identification lamps (switch) Ignition (switch)
Clutch	Illumination intensity
Driver's sun visor	Manual choke
Engine start	Master lighting switch
Engine stop	Position, side marker, end-outline marker, identification or clearance lamps
Electric park brake switch	Rear window defogging and defrosting systems
Electronic stability control system "off"	Steering wheel
Hand throttle	Tail lamps
Hazard warning signal	Transaxle/transmission shifter (except transfer case)
Hazard warning switch	Turn signal
Headlamps	Windshield defogging and defrosting systems
Headlamp high or low beam switch	Windshield washer (washing system)
Heating and air conditioning fan	Windshield wiper (wiping system)
Heating and air conditioning system	

Foot operated controls (if equipped):

Accelerator	Tail lamp
Clutch	Windshield washer (washing system)
Headlamp high or low beam switch	Windshield wiper (wiping system)
Service brake pedal	

Displays (if equipped):

Air brake low pressure	Headlamp high beam
Air bag system readiness	Low brake air pressure telltale
Antilock brake system malfunction	Low brake fluid condition
Battery charging condition	Low tire pressure indication (see MVSS 138)
Brake lining wear-out condition	Odometer (Canada must be metric)
Brake system malfunction (Canada - ISO symbol)	Passenger air bag Status
Brake Pressure (system loss)	Parking brake applied
Electrical charge	Regenerative brake system malfunction
Electronic stability control system "off"	Seat belt (unfastened telltale)
Electronic stability control system malfunction	Speedometer (Canada must be metric)
Engine coolant temperature	Tire pressure monitoring system malfunction
	Transmission control position

Engine oil pressure  
Fuel level  
Gross loss of brake pressure condition  
Hazard warning signal

Turn signal(s)  
Variable brake proportioning system malfunction

If the intermediate or final stage manufacturer installs any of the above controls and displays, they must also meet the requirements of this standard.

**CMVSS 102 and FMVSS 102 – TRANSMISSION SHIFT POSITION SEQUENCE,  
STARTER INTERLOCK AND TRANSMISSION BRAKING EFFECT**  
**Applies to all types of Incomplete Vehicles Contained in this Document**

**TYPE 1 The following statement is applicable to all incomplete vehicle types contained in this document (unless otherwise noted on the cover).**

This incomplete vehicle, when completed, will conform to CMVSS 102 and FMVSS 102 providing no alterations are made which affect the function, physical, chemical, or mechanical properties, environment, location or vital spatial clearances of the components, assemblies or systems, as manufactured by General Motors, including but not limited to those listed below (if equipped):

Automatic (AT) or Manual (MT) Transaxle/Transmission control and identification system, including but not limited to:

AT floor shift mechanism	Automatic transmission/transaxle assembly
AT gear ratios and final drive ratio	Brake - AT interlock controls
AT gear shift sequence and control logic (electrical or mechanical)	Engine starter interlock controls
AT neutral safety switch assembly and wire	AT shift position pattern (knob, plate or label)
AT position indicator linkage and display	Vehicle wiring harnesses
AT steering column assembly	

**CMVSS 103 and FMVSS 103 – WINDSHIELD DEFROSTING AND DEFOGGING SYSTEMS**  
**Applies to all types of Incomplete Vehicles contained in this Document**

**TYPE 1 The following statement is applicable to all types of incomplete vehicles contained in this document (unless otherwise noted on the cover).**

This incomplete vehicle, when completed, will conform to CMVSS 103 and FMVSS 103 providing no alterations are made which affect the function, physical, chemical, or mechanical properties, environment, location or vital spatial clearances of the components, assemblies or systems, as manufactured by General Motors, including but not limited to those listed below (if equipped):

Windshield defrosting and defogging systems, including but not limited to:

Chassis and instrument panel wiring harness assembly	Engine wiring harness
Defroster air distributor assembly (manifold)	Heater and air conditioning wiring harness
Defroster air duct assembly	Heater and defroster assembly (including motor and blower)
Defroster air hoses (distributor to nozzle)	Heater and defroster control (electrical, mechanical, vacuum)
Defroster air to windshield outlet assembly (nozzle) (it affects blower speed)	Heater and radiator hoses/hose assemblies
Defroster outlet to heater assembly adapter	Heater blower motor speed control
Engine control, software and calibration	Side window defroster ducts
Engine coolant pump	Vacuum control hoses and electric actuators
Engine water outlet thermostat assembly	Windshield assembly

**CMVSS 104 and FMVSS 104 - WINDSHIELD WIPING AND WASHING SYSTEMS**  
**Applies to all types of Incomplete Vehicles contained in this Document**

**TYPE 1 The following statement is applicable to all types of incomplete vehicles contained in this document (unless otherwise noted on the cover).**

This incomplete vehicle, when completed, will conform to CMVSS 104 and FMVSS 104 providing no alterations are made which affect the function, physical, chemical, or mechanical properties, environment, location or vital spatial clearances of the components, assemblies or systems, as manufactured by General Motors, including but not limited to those listed below (if equipped):

Windshield wiping and washing systems, including but not limited to:

Vehicle wiring harness and electrical controls	Windshield washing system hoses
Washer reservoir cap	Windshield wiper arm assembly
Water reservoir filler assembly	Windshield wiper blade assembly
Windshield assembly	Windshield wiper linkage assembly
Windshield module attachments	Windshield wiper/washer control
Windshield washer fluid reservoir	Windshield wiper/washer motor/pump assembly
Windshield washer nozzle	

**CMVSS 106 and FMVSS 106 – BRAKE HOSES, HYDRAULIC, AIR AND VACUUM  
Applies to all types of Incomplete Vehicles contained in this Document**

**TYPE 1 The following statement is applicable to all types of incomplete vehicles contained in this document (unless otherwise noted on the cover).**

This incomplete vehicle, when completed, will conform to CMVSS 106 and FMVSS 106 providing no alterations are made which affect the function, physical, chemical, or mechanical properties, environment, location or vital spatial clearances of the components, assemblies or systems, as manufactured by General Motors, including but not limited to those listed below:

Hydraulic, Air, and Vacuum Brake Hoses and assemblies	Labeling requirements
---	-----------------------

**CMVSS 108 – DAYTIME RUNNING LAMPS  
Applies to all types of Incomplete Vehicles contained in this Document**

**TYPE 1 The following statement is applicable to all types of incomplete vehicles contained in this document (unless otherwise noted on the cover).**

This incomplete vehicle, when completed will conform to the Daytime Running Lamps (DRL) requirements of CMVSS 108 providing no alterations are made to the ignition switch, DRL system components or wiring, and any vehicle forward lighting as manufactured by General Motors.

**CMVSS 108 and FMVSS 108 – LAMPS, REFLECTIVE DEVICES  
AND ASSOCIATED EQUIPMENT  
Applies to all types of Incomplete Vehicles contained in this Document**

**TYPE 2 The following statement is applicable to B9Q – Funeral Coach front lamps or V4U – Limousine types of incomplete vehicles contained in this document (unless otherwise noted on the cover).**

This incomplete vehicle, when completed, will conform to CMVSS 108 and FMVSS 108 **IF** it is completed with a body less than 203.2 cm (80 in) in width, and a GVWR of 4536 kg (10,000 lb.) or less provided the following conditions are met:

Each of these devices must be properly installed on the completed vehicle and meet all requirements of CMVSS 108 and FMVSS 108:



- A. The following devices when provided, located and/or wired by General Motors meet the requirements of CMVSS 108 and FMVSS 108:

Back-up lamps	Headlamp dimmer switch
Body control module (BCM)	Headlamp high beam indicator
Center high mounted stop lamp	License plate lamp
Daytime running lamps controls & wiring (Canada)	Owner Manual instructions
Fog lamps (if equipped)	Park lamps
Front side marker lamps	Rear side marker lamps
Front side marker reflex reflectors	Rear side reflex reflectors
Front turn signal lamps	Rear reflex reflectors
Hazard warning flasher	Rear turn signal lamps
Hazard warning signal operating unit	Stop lamps
Headlamps	Tail lamps
	Turn signal control

- B. No part of the completed vehicle shall be installed to prevent any of the devices listed above from meeting their required photometric output at the specified test points. If such interference exists, the applicable devices may have to be relocated or additional devices added to meet the requirements of CMVSS 108 and FMVSS 108. Any CMVSS 108 or FMVSS 108 part shall not be painted.
- C. No alterations are made which affect the function, physical, chemical, or mechanical properties, environment, location or vital spatial clearances of the components, assemblies or systems including but not limited to those listed in A above.

**TYPE 3 The following statement is applicable to the rear lamps on the B9Q - Funeral Coach incomplete vehicle type contained in this document (unless otherwise noted on the cover).**

For rear lamps, rear reflex reflectors, center high mount stop lamp, license plate mounting and turn signal lamp signal failure feature, conformity with CMVSS 108 and FMVSS 108 cannot be determined based upon the components supplied on the incomplete vehicle, and General Motors makes no representation to conformity with the standard.

**CMVSS 110 and FMVSS 110 – TIRE SELECTION AND RIMS FOR MOTOR VEHICLES  
WITH A GVWR OF 4536 kg (10,000 lb) OR LESS  
Applies to all types of Incomplete Vehicles contained in this Document**

**TYPE 2 The following statement is applicable to all types of incomplete vehicles contained in this document (unless otherwise noted on the cover).**

This incomplete vehicle, when completed, will conform to CMVSS 110 and FMVSS 110, providing:

- A. No alterations are made which affect the function, physical or mechanical properties, environment, location or vital spatial clearances of the components, assemblies or systems, as manufactured by General Motors, including but not limited to:

Owner Manual instructions	Wheels
Tires	

- B. GVWR, GAWR front and rear weight ratings as listed in the GVWR/GAWR Table at the beginning of this document are not exceeded.
- C. The tire and wheel information shown in the Fuel Economy and Emissions Table at end of this document must be transferred to the final stage manufacturer's Certification Label and the Tire Information Placard, providing no equipment or tire pressure changes are made, and the final stage manufacturer labels the vehicle in compliance with CMVSS 110 and FMVSS 110.

NOTE: Incomplete Vehicles referenced in this document may be shipped with reduced tire pressures for shipping purposes only.

**CMVSS 111 and FMVSS 111 – REARVIEW MIRRORS**  
**Applies to all types of Incomplete Vehicles contained in this Document**

**TYPE 3** The following statement is applicable to all types of incomplete vehicles contained in this document (unless otherwise noted on the cover).

Conformity with CMVSS 111 and FMVSS 111 cannot be determined based upon the components supplied on the incomplete vehicle, and General Motors makes no representation to conformity with the standard.

**CMVSS 111 and FMVSS 111 – REAR VISIBILITY CAMERA SYSTEMS**  
**Applies to all types of Incomplete Vehicles contained in this Document with a GVWR less than or equal to 4536 kg (10,000 lb.)**

**TYPE 1** The following statement is applicable to the V4U Limousine and B9Q Funeral Coach incomplete vehicles contained in this document, 4536 (10,000 lb) GVWR or less (unless otherwise noted on the cover).

This incomplete vehicle, when completed, will conform to with CMVSS/FMVSS 111 S6.2.3 (response time), S6.2.4 (linger time), S6.2.5 (deactivation) and S6.2.6 (default view) providing no alterations are made which affect the function, physical, chemical, or mechanical properties, environment, location or vital spatial clearances of the components, assemblies or systems, as manufactured by General Motors, including but not limited to those listed below:

Body Control Module (BCM)

Video display

Wiring for video display

**TYPE 2** The following statement is applicable to the V4U Limousine and B9Q Funeral Coach incomplete vehicles contained in this document, 4536 (10,000 lb) GVWR or less (unless otherwise noted on the cover).

This incomplete vehicle, when completed, will conform to with CMVSS/FMVSS 111 S14.3 (durability requirements) provided the GM supplied camera is mounted in a location protected from the spray of water, mud and other substances onto the camera.

**TYPE 3** The following statement is applicable to the V4U Limousine and B9Q Funeral Coach incomplete vehicles contained in this document, 4536 (10,000 lb) GVWR or less (unless otherwise noted on the cover).

Conformity with CMVSS/FMVSS 111 S6.2.1 (field of view) and S6.2.2 (size) cannot be determined based upon the components supplied on the incomplete vehicle, and General Motors makes no representation to conformity with the standard.

**CMVSS 113 and FMVSS 113 – HOOD LATCH SYSTEM**  
**Applies to all types of Incomplete Vehicles contained in this Document**

**TYPE 1** The following statement is applicable to all types of incomplete vehicles contained in this document (unless otherwise noted on the cover).

This incomplete vehicle, when completed, will conform to CMVSS 113 and FMVSS 113 providing no alterations are made which affect the function, physical, chemical, or mechanical properties, environment, location or vital spatial clearances of the components, assemblies or systems, as manufactured by General Motors, including but not limited to those listed below:

Hood latch systems, which may include but are not limited to:

Hood latch (catch) assembly	Hood latch striker plate (hook) and reinforcements
Hood latch cable release system including controls	Hood latch support assembly
Hood latch pilot	

## **CMVSS 114 and FMVSS 114 – THEFT PROTECTION AND ROLLAWAY PREVENTION**

### **Applies to all types of Incomplete Vehicles Contained in this Document**

#### **4536 kg (10,000 lb) GVWR or less**

**TYPE 1** The following statement is applicable to all types of incomplete vehicles contained in this document, 4536 kg (10,000 lb) GVWR or less (unless otherwise noted on the cover).

This incomplete vehicle, when completed, will conform to CMVSS 114 and FMVSS 114 providing no alterations are made which affect the function, physical, chemical, or mechanical properties, environment, location or vital spatial clearances of the components, assemblies or systems, as manufactured by General Motors, including but not limited to those listed below:

Brake-transaxle/transmission interlock controls	Owner Manual Instructions
Electronic Immobilizer	Steering column lock assembly
Engine electronics (ECM/PCM/VCM)	Transaxle/Transmission assembly
Engine starter interlock controls	Transaxle/Transmission assembly neutral start switch and wiring
Ignition key	
Ignition key warning chime system	

## **CMVSS 115 – VEHICLE IDENTIFICATION NUMBER**

### **Applies to all types of Incomplete Vehicles contained in this Document**

**TYPE 1** The following statement is applicable to all types of incomplete vehicles contained in this document (unless otherwise noted on the cover).

This incomplete vehicle, when completed, will conform to CMVSS 115 providing no alterations are made which affect the function, physical, chemical, or mechanical properties, environment, location or vital spatial clearances of the components, assemblies or systems, as manufactured by General Motors, including but not limited to those listed below:

The Vehicle Identification Number (VIN)	VIN plate fasteners
VIN label or plate	

## **CMVSS 116 and FMVSS 116 – MOTOR VEHICLE BRAKE FLUIDS**

### **Applies to all types of Incomplete Vehicles contained in this Document**

**TYPE 1** The following statement is applicable to all types of incomplete vehicles contained in this document (unless otherwise noted on the cover).

The hydraulic brake fluid in this incomplete vehicle, as manufactured by General Motors, will conform to CMVSS 116 and FMVSS 116 providing no alterations are made which affect the physical or chemical properties of the brake fluid.

## **CMVSS 118 and FMVSS 118 – POWER OPERATED WINDOW, PARTITION AND ROOF PANEL SYSTEMS**

### **Applies to all types of Incomplete Vehicles Contained in this Document**

#### **4536 kg (10,000 lb) GVWR or less**

**TYPE 1** The following statement is applicable to all types of incomplete vehicles contained in this document, 4536 (10,000 lb) GVWR or less (unless otherwise noted on the cover).

This incomplete vehicle, if equipped by General Motors with power windows, when completed, will conform to CMVSS 118 and FMVSS 118 providing no alterations are made which affect the function, physical, chemical, or mechanical properties, environment, location or vital spatial clearances of the components, assemblies or systems, as manufactured by General Motors, including but not limited to those listed below (if equipped):

Power window electrical system  
Power window operating system

Power window operating system control logic  
Sunroof operating system  
Sunroof electrical system  
Window glazing material

Final compliance with CMVSS 118 and FMVSS 118 is the responsibility of the final stage manufacturer for any modifications, or added material, components, or systems.

## **CMVSS 124 and FMVSS 124 – ACCELERATOR CONTROL SYSTEMS** **Applies to all types of Incomplete Vehicles contained in this Document**

**TYPE 1 The following statement is applicable to all types of incomplete vehicles contained in this document (unless otherwise noted on the cover).**

This incomplete vehicle, when completed, will conform to CMVSS 124 and FMVSS 124 providing no alterations are made which affect the function, physical, chemical, or mechanical properties, environment, location or vital spatial clearances of the components, assemblies or systems, as manufactured by General Motors, including but not limited to those listed below:

Accelerator/throttle control systems, including but not limited to:

Attachment pin, hole or ball stud to fuel injection unit  
throttle lever  
Cable or rod, throttle or accelerator, and support  
bracket including seals  
Cruise control module, wiring and cable (if equipped)  
Electronic throttle control assembly and related  
wiring

Floor covering material must not be installed under  
pedal or within 25.4 mm (1 in) of side of pedal  
Lever, throttle or accelerator and supporting bracket  
Pedal-throttle or accelerator and attachments  
Spring(s) - throttle or accelerator return

## **CMVSS 126 and FMVSS 126 – ELECTRONIC STABILITY CONTROL SYSTEMS** **Applies to all types of Incomplete Vehicles Contained in this Document** **4536 kg (10,000 lb) GVWR or less**

**TYPE 2 The following statement is applicable to all types of incomplete vehicles contained in this document, 4536 kg (10,000 lb) GVWR or less (unless otherwise noted on the cover).**

This incomplete vehicle when completed will conform to CMVSS 126 and FMVSS 126 provided it is completed in accordance with the following specific conditions by the (intermediate and) final stage manufacturer:

A. Providing no alterations are made which affect the function, physical, chemical, or mechanical properties, environment, location or vital spatial clearances of the components, assemblies or systems, as manufactured by General Motors, including but not limited to those listed below:

Anti-Lock Brake, Traction Control and Electronic  
Stability control system, including sensors and  
control module  
Brake assemblies and components (service/  
parking) - (i.e. power boosters, master cylinder,  
wheel cylinder, calipers, rotors, wheel speed  
sensor, wheel speed sensor wiring, brake lining  
etc.)

Hydraulic brake valves and components  
Master cylinder-warning statement  
Owner Manual instructions  
Parking brake actuator and related mechanical  
components  
Power steering or vacuum lines and routing  
Power steering or vacuum pump  
Tires and Wheels

Brake pedal, brake switch, parking brake hand lever or park brake switch and related mechanical components  
 Brake system electrical controls and logic  
 Gauges and warning devices, and statements  
 Hydraulic brake fluid and reservoirs  
 Hydraulic brake lines, fittings and routings

Stability control system, including control module, sensors and software calibrations  
 Steering control system including related hardware  
 Suspension components (i.e. bushings, control arms, shocks, springs, sway bars)  
 Vacuum brake lines, fittings and routings  
 Vehicle wiring harnesses

- B. The GVWR, GAWR front and rear weight ratings as listed in the GVWR/GAWR Table at the beginning of this document are not exceeded.
- C. The Tire Pressures as listed the Fuel Economy and Emissions Table located at the end of this document must be followed.
- D. The Maximum Allowable Curb Weight kg (lb) (no passengers) of the completed vehicle cannot exceed the restrictions as shown in the table below:
- E. The maximum vertical Center of Gravity (CG) of the completed vehicle cannot exceed the Maximum “Z - Vertical CG Height Restriction Values” at the corresponding “Y - Lateral Center of Gravity Locations” as shown in the table below:

<b>Cadillac XT5, QMV – 235/65R18 Michelin Primacy Tour A/S</b> <b>CMVSS 126 and FMVSS 126 Compliance Certification</b> <b>“X = Longitudinal, Y = Lateral and Z = Vertical Center of Gravity (CG) Restrictions”</b>								
Model Identification	Completed Vehicle Wheelbase in mm (in)	Maximum Allowable Completed Vehicle Curb Weight kg (lb) (no passengers)	Front/Rear Tire Pressures in kpa (psi)	@ X – allowable Longitudinal location (determined by weighing completed vehicle)	@ Y – Lateral CG Offset Location mm (in)			
					-50 (-1.97)	0 (0)	50 (1.97)	
V4U	3972 (156.4) - 4022 (158.4)	TBD	240 (35) / 240 (35)	% front axle weight restricted to range from 50 to 60%	TBD	TBD	TBD	
B9Q	3743 (147.4) - 2895 (153.4)	2425	240 (35) / 240 (35)	% front axle weight restricted to range from 50 to 60%	700	725	700	
					<b>^^^ Maximum Z - Vertical CG Height Restriction Values ^^^</b>			

Note: Regarding the table above “The Maximum Z – Vertical CG Height Restriction Values” are reduced by 1mm (0.039 in.) for every TBDmm (TBD in.) of “@ Y – Lateral CG Offset ... “ A V4U example follows: a Y – Lateral offset of +/-10 mm (0.394 in.) equals a Z – Vertical restriction of TBD mm (TBD in.)

- F. The lateral, longitudinal and vertical vehicle center of gravity locations can be approximated by following the three (3) formulas shown below:

## Lateral Center of Gravity from Center Line of Vehicle Determination

1. Position the vehicle such that all four wheels are resting in the center of the weight scales on a hard and flat horizontal surface as shown.
2. Record the weight at all four corners.

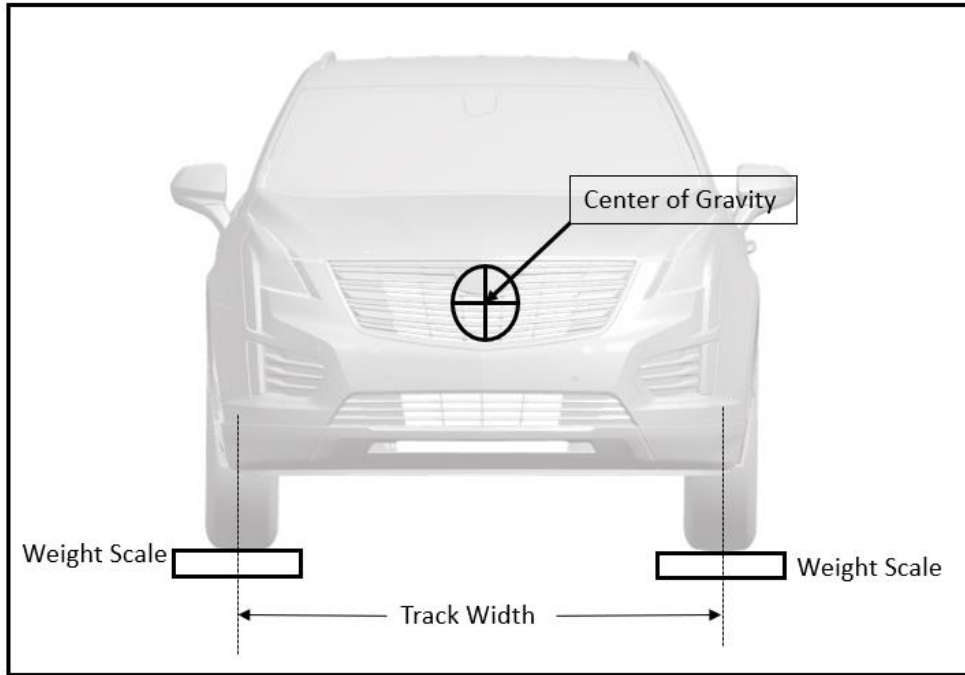

3. For all types of incomplete vehicles contained in this document with an average front track of 1587 mm (62.47 in), the **lateral** center of gravity location is determined by:

$$\frac{\text{Track Width} - \text{Track Width} \times (W_{RF} + W_{RR})}{2 W_T} = C_L \text{ cg}$$

Where:

$W_T$	=	Total vehicle weight = $W_{LF} + W_{RF} + W_{LR} + W_{RR}$
$W_{LR}$	=	Weight at left rear wheel kg (lb)
$W_{RR}$	=	Weight at right rear wheel kg (lb)
$W_{LF}$	=	Weight at left front wheel kg (lb)
$W_{RF}$	=	Weight at right front wheel kg (lb)

## Longitudinal Center of Gravity from Center Line of Vehicle Determination

1. Position the vehicle such that all four wheels are resting in the center of the weight scales on a hard and flat horizontal surface as shown.
2. Record the weight at all four corners.

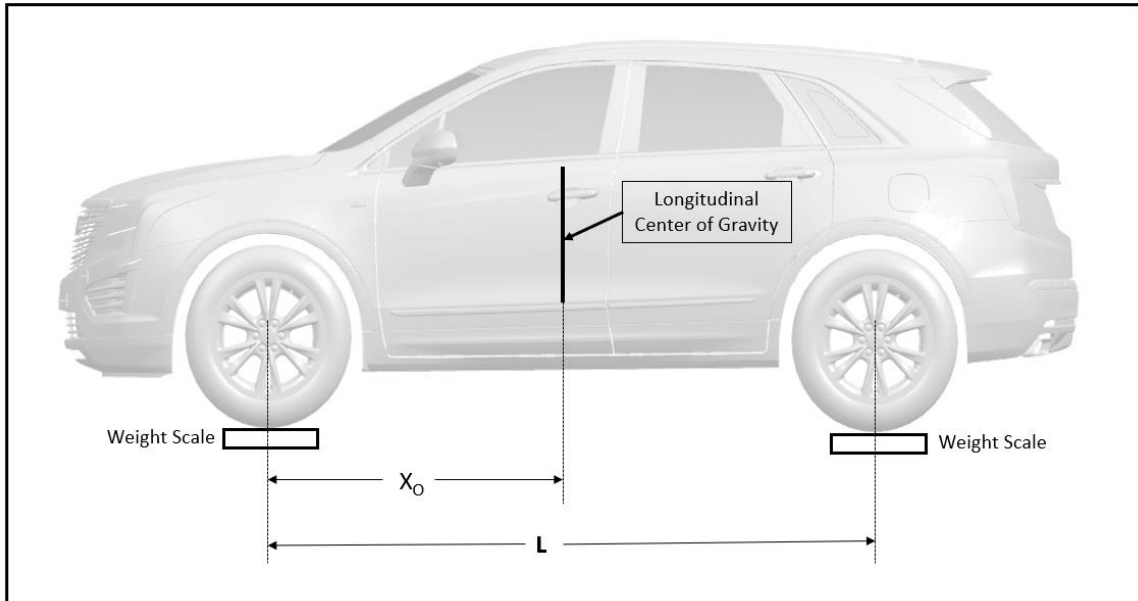

3. The **longitudinal** center of gravity location,  $X_0$ , is determined by:

$$X_0 = (L) \times (W_R/W_T)$$

Where:

$X_0$  = Longitudinal center of gravity from front wheel center line mm (in)

$L$  = Vehicle wheelbase mm (in)

$W_R$  = Rear axle weight =  $W_{LR} + W_{RR}$

$W_T$  = Total vehicle weight =  $W_{LF} + W_{RF} + W_{LR} + W_{RR}$

$W_{LR}$  = Weight at left rear wheel kg (lb)

$W_{RR}$  = Weight at right rear wheel kg (lb)

$W_{LF}$  = Weight at left front wheel kg (lb)

$W_{RF}$  = Weight at right front wheel kg (lb)

### **Vertical Center of Gravity Determination**

1. Position the vehicle with the front tires raised to an incline of at least  $20^\circ$ , as shown below. An overhead or floor hoist is recommended to elevate the front of the vehicle. It must be able to support the weight of the vehicle and be structurally stable. Weight scales are needed under the rear tires only and must be horizontal so that true vertical weight is measured. The rear weight scales must be elevated approximately 381 mm (15 in) to provide sufficient ground clearance to the rear bumper and tail pipe.
2. Record the weight readings of the rear scales.

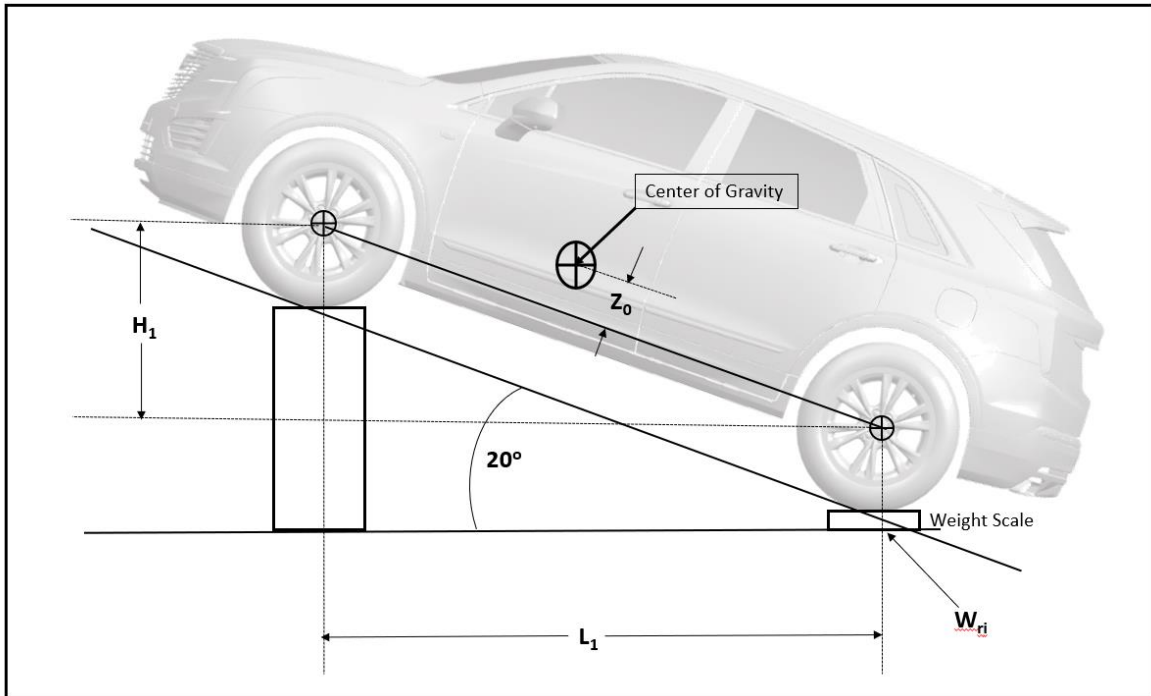

3. The **vertical** center of gravity location  $Z_0$  is determined by:

$$Z_0 = (L_1/H_1) \times (L \cdot W_{RI}/W_T - X_0)$$

Where:

- $L_1$  = Horizontal distance between front and rear wheels on incline mm (in)
- $H_1$  = Vertical distance between front and rear wheels on incline mm (in)
- $L$  = Vehicle wheelbase mm (in)
- $W_{RI}$  = Rear axle weight on incline =  $W_{L_{RI}} + W_{R_{RI}}$
- $W_{L_{RI}}$  = Left rear weight on incline kg (lb)
- $W_{R_{RI}}$  = Right rear weight on incline kg (lb)
- $W_T$  = Total vehicle weight (as previously determined)
- $X_0$  = Longitudinal center of gravity location (as previously determined)



**CMVSS 135 and FMVSS 135 – LIGHT VEHICLE BRAKE SYSTEMS**  
**Applies to all types of Incomplete Vehicles Contained in this Document**  
**with a 3500 kg (7,716 lb) GVWR or less**

**TYPE 2** The following statement is applicable to all types of incomplete vehicles contained in this document with a 3500 kg (7,716 lb) GVWR or less (unless otherwise noted on the cover).

This incomplete vehicle when completed will conform to CMVSS 135 and FMVSS 135 provided the intermediate or final stage manufacturer complete it in accordance with the following specific conditions:

A. Provided no alterations are made which affect the function, physical, chemical, or mechanical properties, environment, location or vital spatial clearances of the components, assemblies or systems including but not limited to those listed below:

- |   |  |
|---|--|
| Anti-Lock Brake System  | Hydraulic brake lines, fittings and routings             |
| Brake assemblies and components (service/parking) (i.e. power boosters, master cylinder, wheel cylinder, calipers, rotors, wheel speed sensor, wheel speed, sensor wiring, brake lining etc.) | Hydraulic brake valves and components                    |
| Brake pedal, brake switch, parking brake hand lever or park brake switch and related mechanical components  | Master cylinder-warning statement                        |
| Brake system electrical controls and logic  | Owner Manual instructions                                |
| Gauges and warning devices, and statements  | Parking brake actuator and related mechanical components |
| Hydraulic brake fluid and reservoirs  | Power steering or vacuum lines and routing               |
|   | Power steering or vacuum pump                            |
|   | Tires and Wheels   |
|   | Vacuum brake lines, fittings and routings                |
|   | Vehicle wiring harnesses                                 |

B. The percent front weight at GVWR and percent front weight in CMVSS 135 and FMVSS 135 lightly loaded condition are met as tabulated below per completed vehicle wheel base and vehicle type. NOTE: The wheelbase as shipped from General Motors is 2854 mm (112.4 in).

**CMVSS 135 and FMVSS 135 BRAKE TABLE**

Completed Vehicle Wheelbase		Vehicle Type	Percent of Front Weight at GVWR (percent)	Percent of Front Weight in Standard 135 Lightly Loaded Condition (percent)
mm	inches			
3972 - 4022	156.4 – 158.4	V4U	44.3 - 48.7	47.0 – 57.0
3743 - 3895	147.4 – 153.4	B9Q	48.7	47.0 – 57.0

C. The completed vehicle wheelbase does not exceed the maximum completed vehicle wheelbase as noted in the CMVSS 135 and FMVSS 135 BRAKE TABLE above.

D. The GVWR, GAWR front and rear weight ratings as listed in the GVWR/GAWR Table at the beginning of this document must not be exceeded.

E. The maximum vertical center of gravity cannot exceed the Z = Vertical Center of Gravity (CG) Restrictions at the 0 mm (in) Y – Lateral CG Offset Location shown in the "... CMVSS 126 and FMVSS 126 Compliance Certification ... Restrictions," table.

**FMVSS 138 – TIRE PRESSURE MONITORING SYSTEM**  
**Applies to all types of Incomplete Vehicles Contained in this Document**  
**with a 4536 kg (10,000 lb) GVWR or less**

**TYPE 2 The following statement is applicable to all types of incomplete vehicles contained in this document with a 4536 kg (10,000 lb) GVWR or less (unless otherwise noted on the cover).**

This incomplete vehicle, when completed, will conform to FMVSS 138, providing the vehicle is equipped with a Tire Pressure Monitoring System (TPMS) installed by General Motors, and no alterations are made which affect the function, physical, chemical, or mechanical properties, environment, location or vital spatial clearances of the components, assemblies or systems including but not limited to those listed below:

Body control module	Tires and Wheels
Instrument panel cluster	TPMS receiver module
Owner Manual Instructions	TPMS sensors integral to the valve stems
Remote start coax antennae (if equipped)	Vehicle wiring harness

All incomplete vehicles shipped from the General Motors assembly plant may have tire pressures set for shipping purposes only. It is the responsibility of the final stage manufacturer to label the vehicle in compliance to FMVSS 138. In addition, it is the responsibility of the final stage manufacturer to ensure the TPMS system is calibrated to the values printed on the final stage manufacturer's Tire Certification Label or Tire Information Label.

Wheelbase alteration, and/or addition of components may interfere with the TPMS radio frequency signal that may result in a malfunction warning displayed in the Driver Information Center (DIC). If this condition is observed, **go to the GM Upfitter Integration website located at [www.gmupfitter.com](http://www.gmupfitter.com)**

NOTE: The TPMS is not required to monitor the spare tire, either when it is stowed or when it is installed on the vehicle.

**CMVSS 201 and FMVSS 201 – OCCUPANT PROTECTION IN INTERIOR IMPACTS**  
**Applies to all types of Incomplete Vehicles Contained in this Document**  
**with a 4536 kg (10,000 lb) GVWR or less**

**TYPE 3 The following statement is applicable to all types of incomplete vehicles contained in this document, with a 4536 kg (10,000 lb) GVWR or less (unless otherwise noted on the cover).**

Conformity with CMVSS 201 and FMVSS 201 cannot be determined based upon the components supplied on the incomplete vehicle, and General Motors makes no representation to conformity with the standard.

**CMVSS 202 and FMVSS 202A – HEAD RESTRAINTS**  
**Applies to all types of Incomplete Vehicles Contained in this Document**  
**4536 kg (10,000 lb) GVWR or less**

**TYPE 1 The following statement is applicable ALL seating positions in the V4U – Limousine incomplete vehicle type contained in this document (unless otherwise noted on the cover).**

This incomplete vehicle, when completed, will conform to CMVSS 202 and FMVSS 202A providing no alterations are made which affect the function, physical, chemical, or mechanical properties, environment, location or vital spatial clearances of the components, assemblies or systems, as manufactured by General Motors, including but not limited to those listed below

Seat assemblies equipped with head restraints	Owner Manual instructions
---	---------------------------

**TYPE 1 The following statement is applicable to FRONT seating positions in the B9Q - Funeral Coach incomplete vehicle type contained in this document (unless otherwise noted on the cover).**

This incomplete vehicle, when completed, will conform to CMVSS 202 and FMVSS 202A providing no alterations are made which affect the function, physical, chemical, or mechanical properties, environment, location or vital spatial clearances of the components, assemblies or systems, as manufactured by General Motors, including but not limited to those listed below

**TYPE 3** The following statement is applicable to REAR seating positions in the B9Q - Funeral Coach incomplete vehicle type or any additional seats installed by the upfitter contained in this document (unless otherwise noted on the cover).

Conformity with CMVSS 202 and FMVSS 202A cannot be determined based upon the components supplied on the incomplete vehicle, and General Motors makes no representation to conformity with the standard.

NOTE: If the intermediate or final stage manufacturer adds or modifies seats as manufactured by General Motors, they are also responsible to provide an addendum to the Owner Manual in order to meet CMVSS 202 and FMVSS 202A requirements.

**CMVSS 203 and FMVSS 203 – IMPACT PROTECTION FOR THE DRIVER FROM  
THE STEERING CONTROL SYSTEM**  
**Applies to all types of Incomplete Vehicles Contained in this Document**  
**with a 4536 kg (10,000 lb) GVWR or less**

**TYPE 1** The following statement is applicable to all types of incomplete vehicles contained in this document (unless otherwise noted on the cover).

This incomplete vehicle, when completed, will conform to CMVSS 203 and FMVSS 203 provided the Maximum Completed Vehicle Curb Weight shown in the FUEL ECONOMY AND EMISSIONS TABLE located within section PART II found later in this document are not exceeded, and no alterations are made which affect the function, physical, chemical, or mechanical properties, environment, location or vital spatial clearances of the components, assemblies or systems including but not limited to those listed below:

Driver's seat assembly  
Instrument panel

Steering control system including related hardware  
Steering wheel, column, and shaft

**CMVSS 204 and FMVSS 204 – STEERING CONTROL REARWARD DISPLACEMENT**  
**Applies to all types of Incomplete Vehicles Contained in this Document**  
**with a 4536 kg (10,000 lb) GVWR or less and**  
**an unloaded vehicle weight of 2495 kg (5,500 lb) or less**

**TYPE 1** The following statement is applicable to all types of incomplete vehicles contained in this document (unless otherwise noted on the cover), with a 4536 kg (10,000 lb) GVWR or less and an unloaded vehicle weight of 2495 kg (5,500 lb) or less (unless otherwise noted on the cover).

This incomplete vehicle, when completed, will conform to CMVSS 204 and FMVSS 204 provided the applicable maximum GVWR and GAWR's shown in the FUEL ECONOMY AND EMISSIONS TABLE located at the end of this document are not exceeded, and no alterations are made which affect the function, physical, chemical, or mechanical properties, environment, location or vital spatial clearances of the components, assemblies or systems including but not limited to those listed below that would affect the steering control system displacement in a 48 kph (30 mph) fixed barrier impact:

Front impact bar assembly and mounting system  
Hood and hinge assemblies  
Powertrain and powertrain mounting system  
Steering control system including related hardware

Steering wheel, column, and shaft assembly  
Tires and wheels  
Vehicle/body front-end sheet metal components  
Vehicle/body front-end structural components  
Vehicle/body roof structure and components

**CMVSS 205 and FMVSS 205 – GLAZING MATERIALS**  
**Applies to all types of Incomplete Vehicles contained in this Document**

**TYPE 1 The following statement is applicable to all types of incomplete vehicles contained in this document (unless otherwise noted on the cover).**

The glazing installed on this incomplete vehicle will conform to CMVSS 205 and FMVSS 205 providing no alterations are made which affect the function, physical, chemical, or mechanical properties, environment, location or vital spatial clearances of the components, assemblies or systems, as manufactured by General Motors, including but not limited to those listed below:

Glazing material  
Monogram

Visibility of the monogram  
Windshield shade banding

The final stage manufacturer is responsible for compliance with CMVSS 205 and FMVSS 205 for any additional glazing installed.

## **CMVSS 206 and FMVSS 206 – DOOR LOCKS AND DOOR RETENTION COMPONENTS** **Applies to all types of Incomplete Vehicles contained in this Document** **with a 4536 kg (10,000 lb) GVWR or less**

**TYPE 1 The following statement is applicable to V4U – Limousine incomplete vehicle type contained in this document, with a 4536 kg (10,000 lb) GVWR or less (unless otherwise noted on the cover).**

This incomplete vehicle, when completed, will conform to CMVSS 206 and FMVSS 206 provided no alterations are made which affect the function, physical, chemical, or mechanical properties, environment, location or vital spatial clearances of the components, assemblies or systems including but not limited to those listed below:

Door and pillar systems, including but not limited to:

Body rear end upper and lower panel  
Door hinges  
Door latch strikers and striker plates  
Door latches  
Door locks  
Door pillars  
Door wedges

Doors  
Exterior door handles  
Inside lock control linkages  
Rear compartment latch and striker assembly  
Rear compartment lid assembly  
Rear compartment lid hinge assembly

Final compliance with CMVSS 206 and FMVSS 206 is the responsibility of the final stage manufacturer for any modifications, or added material, parts, components, or systems.

**TYPE 3 The following statement is applicable to the B9Q - Funeral Coach incomplete vehicle type contained in this document (unless otherwise noted on the cover).**

Conformity with CMVSS 206 and FMVSS 206 cannot be determined based upon the components supplied on the incomplete vehicle, and General Motors makes no representation to conformity with the standard.

## **CMVSS 207 and FMVSS 207 – SEATING SYSTEMS** **Applies to all types of Incomplete Vehicles Contained in this Document**

**TYPE 1 The following statement is applicable to all types of incomplete vehicles contained in this document (unless otherwise noted on the cover).**

This incomplete vehicle, when completed, will conform to CMVSS 207 and FMVSS 207 providing no alterations are made which affect the function, physical, chemical, or mechanical properties, environment, location or vital spatial clearances of the components, assemblies or systems, as manufactured by General Motors, including but not limited to those listed below:

Floor pan assemblies  
Folding seat or seat back latch assembly

Seat assembly  
Seat or seat back latch assembly

Seat adjuster assembly  
Seat anchorage brackets, reinforcements,  
attachment hardware, etc.

Seat or seat back latch release control  
Seat or seat back latch striker  
Seat riser

Final compliance with CMVSS 207 and FMVSS 207 is the responsibility of the final stage manufacturer for any modifications, or added material, parts, components, or systems.

**TYPE 3** The following statement is applicable to all types of incomplete vehicles contained in this document with respect to any seats, seat belt assemblies or seat belt assembly anchorages installed by the intermediate or final stage manufacturer (unless otherwise noted on the cover).

Conformity with CMVSS 207 and FMVSS 207 cannot be determined based upon the components supplied on the incomplete vehicle, and General Motors makes no representation to conformity with the standard.

**CMVSS 208 and FMVSS 208 – OCCUPANT CRASH PROTECTION**  
**Applies to all types of Incomplete Vehicles Contained in this Document**  
**with a 3856 kg (8,500 lb) GVWR or less and**  
**an unloaded vehicle weight of 2495 kg (5,500 lb) or less**

**TYPE 2** The following statement is applicable to the front seating positions in all types of incomplete vehicles contained in this document with the General Motors allowable unloaded vehicle weight of 2495 kg (5,500 lb) or less and a GVWR of 3856kg (8,500 lb) or less (unless otherwise noted on the cover).

A. The front seating positions provided by General Motors will conform to the requirements of CMVSS 208 and FMVSS 208, providing the Unloaded Vehicle Weight does not exceed 2081 kg (4587 lbs) and no alterations are made which affect the function, physical, chemical, or mechanical properties, environment, location or vital spatial clearances of the components, assemblies or systems including but not limited to those listed below:

1. The number, location or configuration of the designated seating positions.
2. The number, placement, installation or model number of the seat belt assemblies provided.
3. The owner manual instructions, the instrument panel or its mounting, the steering column/shaft or its mounting, the knee bag or its mounting, the steering wheel, horn pad, driver air bag module or its mounting and covering, passenger airbag module or its mounting or covering (if equipped), air bag crash sensors. **Note: For the “Passenger Sensing System” (if equipped), modifying or putting a padded cover on the passenger seat can affect the performance of this system.**
4. Sensor Diagnostic Module (SDM) and all air bag system wiring. Do not relocate or move the SDM, or airbag crash sensors. Do not obstruct the path of air bag deployment. Do not mount any components that produce more than a 20 Gauss magnetic field as measured at the SDM. Speakers/*magnets* must be located at least 12.7 cm (5 in) from the SDM. You must disconnect the SDM before doing any welding on the vehicle, otherwise do not disconnect the SDM. **Caution: To help avoid Personal Injury Due to unwanted air bag inflation, observe the following precautions!** Do not weld, solder, braze, hammer, machine, drill, heat, electrical splice, add onto, remove, relocate, test, paint, loosen or in any way alter air bag components or wiring or fuses. Carpet may be put over the SDM if an appropriate moisture barrier (such as a rubber-matted backing) is supplied. When performing any operation around air bag components or wiring, including but not limited to any operations around the instrument panel, electrical wiring and fuse block, steering column/wheel, and the engine compartment, you must disable the air bag system prior to the operation. If the vehicle is equipped with an SDM, you must disable the air bag system prior to installing intermediate or final stage manufacturer components. *Note: Striking or dropping a powered SDM may cause air bag deployment.* The air bag system must be enabled after operation completion. This must be verified before shipping the vehicle. Instructions for disabling and enabling the air bag system can be found in the GM service manual. **Note: All connectors that have wiring routed between the SDM and an air bag inflator module have yellow connectors.**

5. If the sun visor is removed or altered, or if the intermediate or final stage manufacturer installs the sun visor, a new Inflatable Restraints System Caution label must be installed per CMVSS 208 and FMVSS 208 requirements. In order to be in compliance with CMVSS 208 and FMVSS 208 no other label shall be installed on the same side of the sun visor as the Air Bag Caution label. The instrument panel temporary warning label must not be removed.
6. The vehicle frame, front bumper system, front sheet metal or other front structure, roof structure, doors, floor pan, dash panel, cowl structure, driveline or contents of the engine compartment by any incomplete or final stage manufacturer which would result in any difference from the modified vehicle's deceleration if the modified vehicle were to be subjected to barrier impact tests conducted per CMVSS 208 and FMVSS 208.

**TYPE 3 The following statement is applicable to all types of incomplete vehicles contained in this document with respect to any seats, seat belt assemblies or seat belt assembly anchorages installed by the intermediate or final stage manufacturer (unless otherwise noted on the cover).**

Conformity with CMVSS 208 and FMVSS 208 cannot be determined based upon the components supplied on the incomplete vehicle, and General Motors makes no representation to conformity with the standard.

**CMVSS 209 and FMVSS 209 – SEAT BELT ASSEMBLIES**  
**Applies to all types of Incomplete Vehicles Contained in this Document**

**TYPE 1 The following statement is applicable to all types of incomplete vehicles contained in this document (unless otherwise noted on the cover).**

The seat belt assembly provided by General Motors when mounted to its original attachments locations at any designated seating position, will conform to CMVSS 209 and FMVSS 209 providing no alterations are made which affect the function, physical, chemical, or mechanical properties, environment, location or vital spatial clearances of the components, assemblies or systems, as manufactured by General Motors, including but not limited to those listed below:

- |                           |                      |
|---------------------------|----------------------|
| Owner Manual instructions | Seat belt anchorages |
| Seat anchorages           | Seat belt assemblies |
| Seat assemblies           |                      |

**TYPE 3 The following statement is applicable to all types of incomplete vehicles contained in this document with respect to any seats, seat belt assemblies or seat belt assembly anchorages installed by the intermediate or final stage manufacturer (unless otherwise noted on the cover).**

Conformity with CMVSS 209 and FMVSS 209 cannot be determined based upon the components supplied on the incomplete vehicle, and General Motors makes no representation to conformity with the standard.

**CMVSS 210 and FMVSS 210 – SEAT BELT ASSEMBLY ANCHORAGES**  
**Applies to all types of Incomplete Vehicles Contained in this Document**

**TYPE 1 The following statement is applicable to all types of incomplete vehicles contained in this document (unless otherwise noted on the cover).**

This incomplete vehicle, when completed, will conform to CMVSS 210 and FMVSS 210 providing no alterations are made which affect the function, physical, chemical, or mechanical properties, environment, location or vital spatial clearances of the components, assemblies or systems, as manufactured by General Motors, including but not limited to those listed below:

- |  |  |
|--|--|
| B, C, and D-pillar structures  | Seat assemblies  |
| Child restraint system including lower and top tether anchorages, seat brackets, plates and reinforcements | Seat belt assemblies                                     |
| Floor pan assembly   | Seat belt anchorage brackets, plates, and reinforcements |
| Owner Manual instructions  | Seat belt routing  |
|  | Seat position/adjustment capability                      |

Roof structure

**TYPE 3** The following statement is applicable to all types of incomplete vehicles contained in this document with respect to any seats, seat belt assemblies or seat belt assembly anchorages installed by the intermediate or final stage manufacturer (unless otherwise noted on the cover).

Conformity with CMVSS 210 and FMVSS 210 cannot be determined based upon the components supplied on the incomplete vehicle, and General Motors makes no representation to conformity with the standard.

### **CMVSS 210.1 – TETHER ANCHORAGES FOR RESTRAINT SYSTEMS**

**Applies to all types of Incomplete Vehicles Contained in this Document to be completed as a Multipurpose Passenger Vehicle or Truck with a 3856 kg (8,500 lb) GVWR or less and an Unloaded Vehicle Weight of 2495 kg (5,500 lb) or less**

**TYPE 3** The following statement is applicable to all multipurpose passenger vehicle or truck types of incomplete vehicles contained in this document with a 3856 kg (8,500 lb) GVWR or less and an Unloaded Vehicle Weight of 2495 kg (5,500 lb) or less (unless otherwise noted on the cover).

Conformity with CMVSS 210.1 cannot be determined based upon the components supplied on the incomplete vehicle, and General Motors makes no representation to conformity with the standard.

### **CMVSS 210.2 – LOWER UNIVERSAL ANCHORAGE SYSTEMS FOR RESTRAINT SYSTEMS AND BOOSTER CUSHIONS**

**Applies to all types of Incomplete Vehicles Contained in this Document with a 3856 kg (8,500 lb) GVWR or less and an Unloaded Vehicle Weight of 2495 kg (5,500 lb) or less**

**TYPE 3** The following statement is applicable to all multipurpose passenger vehicle or truck types of incomplete vehicles contained in this document with a 3856 kg (8,500 lb) GVWR or less and an Unloaded Vehicle Weight of 2495 kg (5,500 lb) or less (unless otherwise noted on the cover).

Conformity with CMVSS 210.2 cannot be determined based upon the components supplied on the incomplete vehicle, and General Motors makes no representation to conformity with the standard.

### **CMVSS 212 and FMVSS 212 – WINDSHIELD MOUNTING**

**Applies to all types of Incomplete Vehicles Contained in this Document**

**TYPE 2** The following statement is applicable to all types of incomplete vehicles contained in this document with a 4536 kg (10,000 lb) GVWR or less (unless otherwise noted on the cover).

This incomplete vehicle, when completed, will conform to CMVSS 212 and FMVSS 212 if no alterations are made which affect the function, physical, chemical, or mechanical properties, environment, location or vital spatial clearances of the components, assemblies or systems including but not limited to those listed below:

Air bag crash sensors	Seat belt assemblies
Air bag system including covers and module	Sensor Diagnostic Module (SDM) and retainers/brackets
Air bag system wiring harnesses, connectors, and fuses/relays	Steering control system including related hardware
Dash panel and cowl assembly	Steering wheel, column, and shaft assembly
Doors and hinge assemblies	Sun visor assemblies
Frame assembly and mounting system	Vehicle/body front sheet metal components/reinforcements
Front impact bar assembly and mounting system	Vehicle/body front structural components/reinforcements
Hood and hinge assemblies	
Powertrain and powertrain mounting system	
Seat anchorages	

Seat assemblies  
Seat belt anchorages

Vehicle/body roof structure and components  
Windshield and windshield mounting system  
Windshield frame/frame reinforcement

During a 48 kph (30 mph) frontal barrier impact test, no component installed by any intermediate or final stage manufacturer shall move forward from its permanently mounted position.

**CMVSS 213.4 and FMVSS 213 – BUILT-IN CHILD RESTRAINT SYSTEMS  
AND BUILT-IN BOOSTER CUSHIONS**  
**Applies to all types of Incomplete Vehicles contained in this Document**

**TYPE 3** The following statement is applicable to all types of incomplete vehicles contained in this document (unless otherwise noted on the cover).

Conformity with CMVSS 213.4 and FMVSS 213 cannot be determined based upon the components supplied on the incomplete vehicle, and General Motors makes no representation to conformity with the standard.

**CMVSS 214 and FMVSS 214 – SIDE IMPACT PROTECTION**  
**Applies to all types of Incomplete Vehicles contained in this Document**  
**4536 kg (10,000 lb) GVWR or less – Static**  
**4536 kg (10,000 lb) GVWR or less – Dynamic (Oblique Vehicle to Pole Impact)**  
**2722 kg (6,000 lb) GVWR or less – Dynamic (Side Moving Deformable Barrier)**

**TYPE 3** The following statement is applicable to all types of incomplete vehicles contained in this document. (unless otherwise noted on the cover).

Conformity with CMVSS 214 and FMVSS 214 cannot be determined based upon the components supplied on the incomplete vehicle, and General Motors makes no representation to conformity with the standard.

**CMVSS 216 and FMVSS 216a – ROOF CRUSH RESISTANCE**  
**Applies to all types of Incomplete Vehicles contained in this Document**  
**with a 4536 kg (10,000 lb) GVWR or less**

**TYPE 3** The following statement is applicable to all types of incomplete vehicles contained in this document (unless otherwise noted on the cover).

Conformity with CMVSS 216 and FMVSS 216a cannot be determined based upon the components supplied on the incomplete vehicle, and General Motors makes no representation to conformity with the standard.

**CMVSS 219 and FMVSS 219 – WINDSHIELD ZONE INTRUSION**  
**Applies to all types of Incomplete Vehicles contained in this Document**  
**with a 4536 kg (10,000 lb) GVWR or less**

**TYPE 2** The following statement is applicable to all types of incomplete vehicles contained in this document (unless otherwise noted on the cover).

This incomplete vehicle, when completed, will conform to CMVSS 219 and FMVSS 219 providing:

- A. No alterations are made which affect the function, physical, chemical, or mechanical properties, environment, location or vital spatial clearances of the components, assemblies or systems including but not limited to those listed below:



Antennae	Hood assembly
Body roof structure and components/reinforcements	Hood mounts
Body sheet metal components/reinforcements	Motor compartment structure and components
Body structural components/reinforcements	Windshield wiper
Dash panel and cowl structure	Windshield wiper motor
Front, rear and side glazing materials and mounting	

- B. The vehicle does not exceed the vehicle test weight specified in the FUEL ECONOMY AND EMISSIONS TABLE located within section PART II found later in this document.
- C. During a 48 kph (30 mph) frontal barrier impact test:
1. No component installed by any intermediate or final stage manufacturer shall prevent the hood from folding in its designed folding pattern; and
  2. No component installed by any intermediate or final stage manufacturer shall penetrate the windshield or protected zone.

**CMVSS 220 and FMVSS 220 – SCHOOL BUS ROLLOVER PROTECTION**  
**For all types of Incomplete Vehicles Contained in this Document using CMVSS 220 or FMVSS 220 as an Alternative Compliance procedure for CMVSS 216 or FMVSS 216a**

**TYPE 3** The following statement is applicable to all types of incomplete vehicles contained in this document (unless otherwise noted on the cover).

Conformity with CMVSS 220 and FMVSS 220 cannot be determined based upon the components supplied on the incomplete vehicle, and General Motors makes no representation to conformity with the standard.

**FMVSS 225 – CHILD RESTRAINT ANCHORAGE SYSTEMS**  
**Applies to all types of Incomplete Vehicles Contained in this Document**  
**3855 kg (8,500 lb) GVWR or less**

**TYPE 3** The following statement is applicable to all types of incomplete vehicles contained in this document with seats installed by General Motors (unless otherwise noted on the cover).

Conformity with FMVSS 225 cannot be determined based upon the components supplied on the incomplete vehicle, and General Motors makes no representation to conformity with the standard.

**CMVSS 226 and FMVSS 226 – EJECTION MITIGATION**  
**Applies to all types of Incomplete Vehicles Contained in this Document**  
**4536 kg (10,000 lb.) GVWR or less**

**TYPE 3** The following statement is applicable to all types of incomplete vehicles contained in this document, 4536 kg (10,000 lb.) GVWR or less (unless otherwise noted on the cover).

Conformity with CMVSS 226 and FMVSS 226 cannot be determined based upon the components supplied on the incomplete vehicle, and General Motors makes no representation to conformity with the standard.

**CMVSS 301 and FMVSS 301 – FUEL SYSTEM INTEGRITY**  
**Applies to all types of Incomplete Vehicles contained in this Document**  
**with a 4536 kg (10,000 lb) GVWR or less**

**TYPE 3** The following statement is applicable all types of incomplete vehicles contained in this document with a 4536 kg (10,000 lb) GVWR or less. (unless otherwise noted on the cover).

Conformity with CVMSS 301 and FMVSS 301 cannot be determined based upon the components supplied on the incomplete vehicle, and General Motors makes no representation to conformity with the standard.

### **CMVSS 302 and FMVSS 302 - FLAMMABILITY OF INTERIOR MATERIALS** **Applies to all types of Incomplete Vehicles contained in this Document**

**TYPE 1** The following statement is applicable to all types of incomplete vehicles contained in this document (unless otherwise noted on the cover).

This incomplete vehicle, when completed will conform to CMVSS 302 and FMVSS 302 providing no alterations are made which affect the function, physical, chemical, or mechanical properties, environment, location or vital spatial clearances of the components, assemblies or systems, as manufactured by General Motors, including but not limited to those listed below:

All trim panels including door, front, rear and side panels	Instrument panel
Arm rests	Seat assemblies
Compartment shelves	Seat backs
Console	Seat belts
Engine compartment covers	Seat cushions
Floor coverings	Shades
Head restraints	Sun visors
Headlining	Wheel housing covers

NOTE: The list above also includes any other interior materials, such as padding and crash-deployed elements that are designed to absorb energy on contact by occupants in the event of a crash.

**TYPE 3** The following statement is applicable to all types of incomplete vehicles contained in this document (unless otherwise noted on the cover). If the intermediate or final stage manufacturer installs any items but not limited to those listed above (examples: Curtains, Engine compartment cover, Mattress covers, Shades and Wheel housing covers, etc.), they must also meet the requirements of this CMVSS 302 and FMVSS 302.

Conformity with CMVSS 302 and FMVSS 302 cannot be determined based upon the components supplied on the incomplete vehicle, and General Motors makes no representation to conformity with the standard.

### **FMVSS 403 – PLATFORM LIFT SYSTEMS** **Applies to all types of Incomplete Vehicles contained in this Document**

**TYPE 3** The following statement is applicable to all types of incomplete vehicles contained in this document (unless otherwise noted on the cover).

Conformity with FMVSS 403 cannot be determined based upon the components supplied on the incomplete vehicle, and General Motors makes no representation to conformity with the standard.

### **FMVSS 404 – PLATFORM LIFT INSTALLATIONS IN MOTOR VEHICLES** **Applies to all types of Incomplete Vehicles contained in this Document**

**TYPE 3** The following statement is applicable to all types of incomplete vehicles contained in this document (unless otherwise noted on the cover).

Conformity with FMVSS 404 cannot be determined based upon the components supplied on the incomplete vehicle, and General Motors makes no representation to conformity with the standard.

## PART II

### U.S. EPA, CALIFORNIA, AND CANADIAN EXHAUST & EVAPORATIVE EMISSION REQUIREMENTS AND EPA/NHTSA GREENHOUSE GAS EMISSIONS/FUEL ECONOMY REGULATIONS

Incomplete vehicles come in three major classifications: (1) Light Duty Vehicles, Light Duty Trucks, and Heavy Duty Vehicles (Including Medium Duty in California) are certified by the primary manufacturer and the vehicle is labeled as being in compliance with emission and fuel economy requirements. (2) Heavy Duty Vehicles are required to have an engine certified by the engine manufacturer and bear an engine emissions label, and if a gasoline vehicle, bear an evaporative emissions label. (3) Light Duty Vehicles certified and labeled by the intermediate or final stage vehicle manufacturer as being in compliance with emission and fuel economy requirements.

In addition, all gasoline/gasoline-ethanol blend powered Federal/California Light Duty, Medium Duty and Heavy Duty Vehicles are required to have an approved fuel evaporative emission control system. Vehicles certified to Heavy Duty gasoline emission standards also require special evaporative emission labeling. In order to assure that Environmental Protection Agency (EPA), National Highway Traffic Safety Administration (NHTSA), California and Canada Emission Certification and/or Greenhouse Gas/Fuel Economy regulations are met, this vehicle must be completed in strict accordance with all instructions contained in this manual, especially the following instructions which relate to:

#### EMISSION RELATED COMPONENTS

**TYPE 1 The following statement is applicable to all types of incomplete vehicles contained in this document (unless otherwise noted on the cover).**

- A. This incomplete vehicle, when completed, will conform to U.S. EPA, CALIFORNIA, AND CANADIAN EXHAUST & EVAPORATIVE EMISSION REQUIREMENTS AND EPA/NHTSA GREENHOUSE GAS EMISSIONS/FUEL ECONOMY REGULATIONS providing the vehicle is completed in strict accordance with all statements included in this document, especially those that relate to: "EMISSION RELATED COMPONENTS, and no alterations are made which affect the function, physical, chemical, or mechanical properties, environment, location or vital spatial clearances of the components, assemblies or systems, as manufactured by General Motors, including but not limited to those listed below (if equipped):

Air Injection Reaction (AIR) System

Axle

Brake System

Catalytic Converter

Components for All Wheel Drive (AWD) System:

axle, Power Take-Off Unit (PTU), propshaft

Diesel Exhaust Emission Reduction Fluid (DEF)

system, including, but not limited to:

associated plumbing, fill neck assembly

heated delivery line, heater, injector, level

sensor, pump, sensors, tank temperature

sensor

Diesel Exhaust System, including, but not

limited to: NOx Sensors, NOx Sensor Control

Module, Diesel Exhaust (HCI) Direct Fuel

Injector System, associated plumbing,

injectors, injector controller and calibrations

Diesel/Bio-Diesel blend Particulate Filter (DPF)

system, including, but not limited to:

diesel/bio-diesel blend particulate filter

assembly diesel/bio-diesel blend oxidation

catalyst assembly, exhaust system pressure

differential assembly and/or plumbing, exhaust

temperature sensor

Engine Assembly, including, but not limited to:

cooling fan and drive system, crankcase

emission control system, evaporative

emission control system, Exhaust Gas

Recirculation (EGR) system, fuel delivery and

injection system, glow plugs, Glow Plug

Control Module (GPCM), ignition system,

Positive Crankcase Ventilation (PCV) system

Engine Electronics, including, but not limited to:

coolant temperature sensor,

ECM/GPCM/PCM/VCM, engine speed

sensor, mass air flow sensor,

calibrations/software

Exhaust oxygen sensors

Exhaust system

Intake System, including, but not limited to: air

induction components/system ducts, filter,

mass air flow sensor, intake air heater

Onboard Diagnostics Emission System

Tires and Wheels

Transaxle/Transmission Assembly

Transaxle/Transmission Electronics, including,

but not limited to: calibrations/software

Transmission Control Module (TCM)

Turbo Charging System, associated equipment and controls

- B. The front and rear tires pressures must be inflated to the values shown in the FUEL ECONOMY AND EMISSIONS TABLE that appears below.
- C. The Frontal Area and Vehicle Test Weight shown in the FUEL ECONOMY AND EMISSIONS TABLE that appears below must not be exceeded.

NOTES: All Federal/California gasoline/gasoline-ethanol blend powered heavy duty vehicles (except those equipped with option NJ2, Temporary Fuel Tank) will have an evaporative emission control system that is certified for a fuel tank capacity not to exceed the amount shown on the Vehicle Emission Control Information Label. Intermediate or Final Stage Manufacturers wishing to add fuel tank capacity beyond the original equipment fuel tank capacity must contact California Air Resources Board and/or submit a written statement to the EPA Administrator that the Hydrocarbon Storage System has been upgraded according to the requirements of 40 CFR 86.095-35 (g) (2).

Vehicles equipped with option NJ2 - Temporary Fuel Tank do not have an evaporative emission control system.

- D. Further compliance with applicable fuel evaporative emission regulations will be maintained if no alterations are made to the fuel filler neck

Compliance with applicable fuel evaporative emission regulations will be maintained if no alterations are made to change material or increase the size or length or position of the following non-metallic fuel and evaporative emission hoses:

Fuel feed hoses front and rear	Fuel vapor lines at canister
Fuel return hoses front and rear	Fuel vapor lines from engine to chassis pipes
Fuel tank filler hoses to filler neck	Fuel vapor lines from fuel tank sender
Fuel tank vent hoses to filler neck	to chassis pipes

- E. This incomplete vehicle, when completed, will have an estimated fuel economy value determined in accordance with 40 CFR Part 600. This value is displayed on a fuel economy label prepared in accordance with the United States Environmental Protection Agency's fuel economy regulations by General Motors and furnished with this vehicle.

This incomplete vehicle, when completed, must not exceed the "Maximum Completed Vehicle Curb Weight" in the FUEL ECONOMY AND EMISSIONS TABLE shown below. To do so will invalidate the fuel economy value determined by the GM Powertrain – Emission Compliance and Certification Group, General Motors, and the emissions certification issued by the United States Environmental Protection Agency or the state of California, where applicable.

This incomplete vehicle, when completed, must not exceed the maximum body frontal area, listed below (specific per vehicle), and must not exceed the total Road Load Horsepower (RLHP) setting, listed below (per vehicle and weight class). To do so will invalidate the fuel economy value determined by the GM Powertrain – Emission Compliance and Certification Group, General Motors and the emissions certification issued by the United States Environmental Protection Agency or the state of California where applicable. RLHP setting and measuring procedures are described in Mobile Source Air Pollution Control Advisory Circular number 55c, for twin roll dynamometer procedures and EPA's Dear Manufacturer guidance letter VPCD-98-16 for single roll procedures, both of which are available from the United States Environmental Protection Agency.

## FUEL ECONOMY AND EMISSIONS TABLE

Incomplete Vehicle Type	GM Tire Size	Cold Tire Pressure Front		Cold Tire Pressure Rear		Frontal Area		RLHP Setting		Vehicle Test Weight Class		Maximum Completed Vehicle Curb Weight	
		psi	kpa	psi	kpa	ft <sup>2</sup>	m <sup>2</sup>	hp	kw	kg	lb	kg	lb
V4U	235-65-R18	35	240	35	240	33.7	3.13	18.1	13.5	2495	5500	2232	5119
B9Q	235-65-R18	35	240	35	240	33.7	3.13	18.1	13.5	2495	5500	2427	5350

NOTES: The “Vehicle Test Weight” (shown above) includes the weight of a vehicle with standard equipment, oil, lubricants, coolant and a full tank of fuel also including 136 kg (300 lb) to allow for the weight of two 68 kg (150 lb) passengers.

“Vehicle Curb Weight” (shown above) is defined as the weight of a “completed vehicle” with standard equipment, oil, lubricants, coolant and a full tank of fuel. Note: This definition may differ from definitions used by governmental regulatory agencies.

### **SPECIFICATION FOR FILL PIPES AND OPENINGS OF 2016 AND SUBSEQUENT MODEL MOTOR VEHICLE FUEL TANKS (APPLICABLE ONLY TO CALIFORNIA GASOLINE/GASOLINE-ETHANOL BLEND POWERED VEHICLES)**

**TYPE 2 The following statement is applicable to all types of incomplete vehicles contained in this document (unless otherwise noted on the cover).**

This incomplete vehicle, when completed, will conform to Title 13, California Code of Regulations Section 2235, and the “Specifications for Fill Pipes and Openings of 2015 and subsequent Model Year Motor Vehicle Fuel Tanks”, dated March 22, 2012, providing no alterations are made which affect the function, physical, chemical, or mechanical properties, environment, location or vital spatial clearances of the fuel filler neck.

### **LABELS**

**TYPE 2 The following statement is applicable to all types of incomplete vehicles contained in this document (unless otherwise noted on the cover).**

This incomplete vehicle, when completed, will conform to U.S. EPA, CALIFORNIA, AND CANADIAN EXHAUST & EVAPORATIVE EMISSION REQUIREMENTS AND EPA/NHTSA GREENHOUSE GAS EMISSIONS/FUEL ECONOMY REGULATION labeling requirements providing no alterations are made which affect the function, physical, chemical, or mechanical properties, environment, location or vital spatial clearances of the Emission Control related Information Labels that are permanently affixed. The labels are required by government regulation and must not be obstructed from view or defaced to impair their visibility or legibility. In addition, an EPA/DOT Fuel Economy and Environment Label may be affixed to the window glass of the incomplete vehicle as manufactured by General Motors. If equipped, the label must remain in place until the ultimate customer receives this vehicle.

# NOTES

---