

Table of Contents

PICKUP BOX REMOVAL PROGRAM	3
Alterations to Complete Vehicles	3
Areas of Modification:.....	5
CMVSS and FMVSS	5
C/K Light Duty Pickup Fuel Fill System Modifications for Gasoline & Diesel fueled Vehicles	6
C/K Heavy Duty Pickup Fuel Fill System Modifications for Gasoline & Diesel fueled Vehicles	7
C/K LD ZW9/Box Removal Fuel Filler Positioning	8
C/K LD ZW9/Box Removal PU Fuel Filler	9
K LD ZW9 Fuel Filler Shipping Location	10
CK HD ZW9/Box Removal PU Fuel Fillers (Carry-Over Body Style)	11
CK HD ZW9/Box Removal PU Fuel Filler (Carry Over Body Style)	12
CK HD ZW9 PU Fuel Filler Shipping Location	13
CK HD `Pickup` ZW9/Box Removal DIESEL Fuel Filler Shipping Location (All New Body Style)	14
CK HD `Pickup` ZW9/Box Removal DIESEL Fuel Filler Positioning (All New Body Style).....	15
CK HD `Pickup` ZW9/Box Removal GAS Fuel Filler Shipping Location (All New Body Style)	16
CK HD `Pickup` ZW9/Box Removal GAS Fuel Filler Positioning (All New Body Style).....	17
CK HD `Cab Chassis` ZW9 DIESEL Fuel Filler Shipping Location (All New Body Style)	18
CK HD `Cab Chassis` ZW9 DIESEL Fuel Filler Positioning (All New Body Style)	19
CK HD `Cab Chassis` ZW9 GAS Fuel Filler Shipping Location (All New Body Style)	20
CK HD `Cab Chassis` ZW9 GAS Fuel Filler Positioning (All New Body Style)	21
CK HD ZW9 Cab Chassis Filler/Upfit Body Attachment	22

CK LD/HD ZW9 Gas Vapor Sensor (Shipped Loose)	23
CK HD ZW9 rear axle vent shipping location	24
CK HD ZW9 rear axle vent attachment.....	25
CK HD `Pickup` ZW9/Box Removal DEF Tank & Fill `In the Gap` Positioning (All New Body Style).....	26
CK HD `Cab Chassis` ZW9 DEF Tank Outboard Frame Rail Location (All New Body Style)	27
CK HD `Cab Chassis` ZW9 DEF Tank Inboard Frame Rail Relocation (All New Body Style).....	28
CK HD `Cab Chassis` ZW9 DEF Tank Inboard Frame Rail Relocation Kit (All New Body Style).....	29
CK HD `Cab Chassis` ZW9 DEF Tank Inboard Frame Rail Relocation Kit(All New Body Style).....	29
CK HD `Cab Chassis` ZW9 DEF Tank Fill `In the Gap` Positioning (All New Body Style)	30
CK HD `Cab Chassis` ZW9 DEF Tank Fill `Wheel House` Positioning (All New Body Style).....	31

PICKUP BOX REMOVAL PROGRAM

Alterations to Complete Vehicles

Important: GM Validates & Certifies the 8 foot or 'Long Box' 56" CA (Cab to Axle) Chassis models for RPO-ZW9 Factory Box Delete and Pickup Box Removal. Other additional model Box/CA combinations require the Second Stage Manufacturer/Upfitter to complete any FMVSS/CMVSS etc. certification related compliance.

Please refer to corresponding specific vehicle/model as equipped IVD (Incomplete Vehicle Document) RPO-ZW9 Metrics & FMVSS/CMVSS Certification information for Pickup Box Removal upfits. For 'Available Rear Upfit Body Weight' (with payload) use IVD 'Table A ' chart Maximum Unloaded Vehicle Weight (Completed Vehicle Maximum Weight) metrics, minus Rear Curb.

Persons who alter complete (certified) Pickup Trucks by removal of the Pickup box should be aware that this type of activity would impose upon them the corresponding responsibility for ensuring that the units as sold are in compliance with all applicable safety and/or emissions (including noise and RFI) requirements. Specific questions concerning compliance or certification to these requirements should be directed to the vehicle modifier's legal counsel or the National Highway Traffic Safety Administration, the Environmental Protection Agency, the California Air Resources Board, or in Canada, the Ministry of Transport or the Canadian Department of Commerce.

The Environmental Protection Agency has provided an explanation of the policy they will follow regarding the modification by the secondary manufacturers of complete Light Duty Trucks prior to sale and delivery to the ultimate purchaser. This explanation is contained in a letter from C.

N. Freed of the EPA to M.H. McBride of the Recreation Vehicle Industry Association, dated July 13, 1979. A portion of this letter states: "...Secondary manufacturers are not manufacturers under the [Clean Air] Act when the following conditions are met:

1. The vehicles produced by a secondary manufacturer conform in all material respects to the design specification in the original manufacturer's application for certification (hereafter 'Application'); and
2. The weight of the vehicles produced by a secondary manufacturer, including the weight of fuel at nominal tank capacity, is no more than 500 lbs. above the maximum vehicle weight."

No frontal area restrictions will apply to secondary manufacturers who comply with the conditions above. However, every vehicle sold to an ultimate purchaser must be covered by emission warranty mandated by section 207(a) of the Act. Secondary manufacturers who do not meet the above conditions will be considered manufacturers under the Act and will be required to ensure that the vehicles they produce are covered by a certificate of conformity.

The Maximum vehicle weight for a given vehicle is determined by:

- A) Subtracting 300 lbs. from the highest loaded vehicle weight (see 40 CFR 86.082-2 for loaded vehicle weight definition and the table at 40 CFR 86.129-94) associated with the test weight listed in the application for the vehicle, and
- B) Adding the weight of all options that are offered by the original manufacturer for the applicable truck line that were not included in the curb weight reported in the application.

In the case of mutually exclusive options, only the weight of the heavier option is to be used when computing the maximum vehicle weight.
(Alterations – continued from previous page)

In addition, the California Air Resources Board has provided an explanation of the policy they will follow regarding the modification by the secondary manufacturers of complete Light Duty Trucks prior to sale and delivery to the ultimate purchaser. This explanation is contained in the California Exhaust Emission Standards and Test Procedures for Passenger Cars, Light Duty Trucks and Medium Duty Vehicles, adopted March 22, 2012 and dated December 6, 2012.

A portion of this document states:

“Certification, if granted, is effective only for the vehicle/test group described in the original manufacturer’s certification application.

Modifications by a secondary manufacturer to vehicles/engines shall be deemed not to increase emissions above the standards under which those vehicles/engines were certified and to be within the original certification if such modifications do not: (1) increase vehicle weight more than 10 percent above the curb weight, increase frontal area more than 10 percent, or result in a combination increase of weight plus frontal area of more than 14 percent; or (2) include changes in axle ratio, tire size, or tire type resulting in changes in the drive train ratio of more than 5 percent; or (3) include any modification to the emission control system. No originally certified vehicle/engine which is modified by a secondary manufacturer in a manner described in items (1) through (3) of the preceding sentence may be sold to an ultimate purchaser, offered or delivered for sale to an ultimate purchaser, or registered in California unless the modified vehicle/engine is certified by the state board in accordance with applicable test procedures to meet emission standards for the model year for which the vehicle/engine was originally certified. For the purposes of this subsection, “secondary manufacturer” means any person, other than the original manufacturer, who modifies a new motor vehicle prior to sale to the ultimate purchaser.”

Those who wish to remove the Pickup box from a Pickup Truck for the purpose of installing special equipment or another type of body should be further advised that a Pickup may require modification in one of the following areas. Before a decision is made to alter a C/K Pickup Model, please be advised of the following considerations:

Vehicle:

Analyze the vehicle specifications for product content. The option content of a particular vehicle will determine which if any of the five areas of modification might not be applicable to the vehicle alterations contemplated.

Service Parts:

The service parts and related service part number as outlined in the five areas of modification may be ordered through your local Chevrolet/GMC Dealer. Contact your Dealer’s Service Parts Representative for availability and price.

Areas of Modification:

1. Fuel filler neck assembly, housing, and ground strap.
2. Rear axle vent hose.
3. Tail lamp, tail lamp wiring harness and license plate bracket assembly.
4. Spare tire mounting.
5. Body pressure relief valve (see UI Bulletin #44).

CMVSS and FMVSS

Compliance of Canadian and Federal Motor Vehicle Safety Standards will be affected by Upfitters removing Pickup Box and Rear Bumper to install a second unit body:

MVSS 105 – Hydraulic brake (Vehicles greater than 3500 kg (7716 lb) GVWR)

MVSS 108 – Lighting Equipment

MVSS 111 – Rear View Mirrors

MVSS 135 – Light Vehicle Brakes, applies to vehicles 3500 kg (7716 lb) GVWR or less

MVSS 204 – Steering Control Rear Displacement

MVSS 208 – Occupant Crash Protection

MVSS 219 – Windshield Zone Intrusion 4536 kg (10,000 lb) or less

MVSS 301 – Fuel System Integrity, trucks

Note: Generic copies of the General Motor Incomplete Vehicle Documents can be obtained from the website (www.qmupfitter.com) and can be used as a reference guide in the compliance to these standards.

C/K Light Duty Pickup Fuel Fill System Modifications for Gasoline & Diesel fueled Vehicles

Certain guidelines must be adhered to in modifying the fuel fill and vent system to ensure that the completed product meets the manufacturer's requirements.

- 1.** The fuel fill and vent system, including rear differential vent, must be installed such that there is adequate clearance between the fuel fill vent system and the tires under all operating conditions, including protection from road debris. Shielding the fuel pipe is recommended to adequately protect from damage that may occur under conditions of tread and or belt separation from the tire. Shielding must have friendly, non-sharp surfaces and no fasteners shall be facing in the direction of the fuel filler pipe assembly. Upfit Body attachment brackets must also be located such that there is adequate clearance to all fuel system components, such as the fuel lines and the fuel level sending unit, under all operating conditions.
- 2.** The fuel fill/vent pipe system attached to the vehicle frame upon delivery must be positioned in the location shown in this document in order to meet vehicle Federal US EPA and California emission and certification requirements. Fill hose, vent hose, and fill pipe must not be altered.
- 3.** Both the fill and the vent hoses must be routed and supported, if needed, such that there are no sags or kinks. Routing and location shown in this document are required in order to meet vehicle Federal US EPA and California emission and certification requirements.
- 4.** The fuel fill and vent system should be restrained in the upfit vehicle. This is necessary to avoid chaffing, fretting, rubbing etc. which may cause wear to pipes and hoses.
- 5.** The fuel fill pipe inlet area of the fill pipe assembly maintained at 35 degrees from ground (horizontal).
- 6.** Fuel fill hose clamp between the fuel tank inlet check valve and the fill pipe hose is to be tightened to 4 Nm +/-0.5Nm (dynamic) torque (as assembled from the GM Assembly Plant). The clamp between the fuel fill pipe inlet and the fill pipe hose is to be tightened to 4.5Nm +/-0.5 Nm (dynamic) torque (as assembled at the fill pipe supplier).

C/K Heavy Duty Pickup Fuel Fill System Modifications for Gasoline & Diesel fueled Vehicles

Certain guidelines must be adhered to in modifying the fuel fill and vent system to ensure that the completed product meets the manufacturer's requirements.

- 1.** The fuel fill and vent system, including rear differential vent, must be installed such that there is adequate clearance between the fuel fill vent system and the tires under all operating conditions, including protection from road debris. Body attachment brackets must also be located such that there is adequate clearance to all fuel system components, such as the fuel lines and the fuel level sending unit, under all operating conditions.
- 2.** The fuel fill and vent system should be restrained in the upfit vehicle. This is necessary to avoid chaffing, fretting, rubbing etc. which may cause wear to pipes and hoses.
- 3.** The fuel fill/vent pipe system hoses can be trimmed to adjust for the various chassis lengths and body widths. Pipes should not be modified, alterations could be detrimental to satisfactory assembly and/or function.
- 4.** A minimum of 8.0 inches of fill hose must be maintained between the filler neck and the fuel tank as measured in an outboard direction from the tank surface (at the fill hose nipple) to the outlet end of the filler neck.
- 5.** Both the fill and the vent hoses must be routed (and supported, if needed) such that there are no sags or kinks. Excess hose length may be removed as required provided hose does not kink. As viewed from the filler neck, pipes and hoses must have a min downward slope of 4° of downward slope at any location.
- 6.** Fuel fill hose clamp between the fuel tank inlet check valve and the fill pipe hose is to be tightened to 4 Nm GAS, 5NmDIESEL +/-0.5Nm (dynamic) torque (as assembled from the GM Assembly Plant). The clamp between the fuel fill pipe inlet and the fill pipe hose is to be tightened to 4.5Nm +/-0.5 Nm (dynamic) torque (as assembled at the fill pipe supplier).

C/K LD ZW9/Box Removal Fuel Filler Positioning

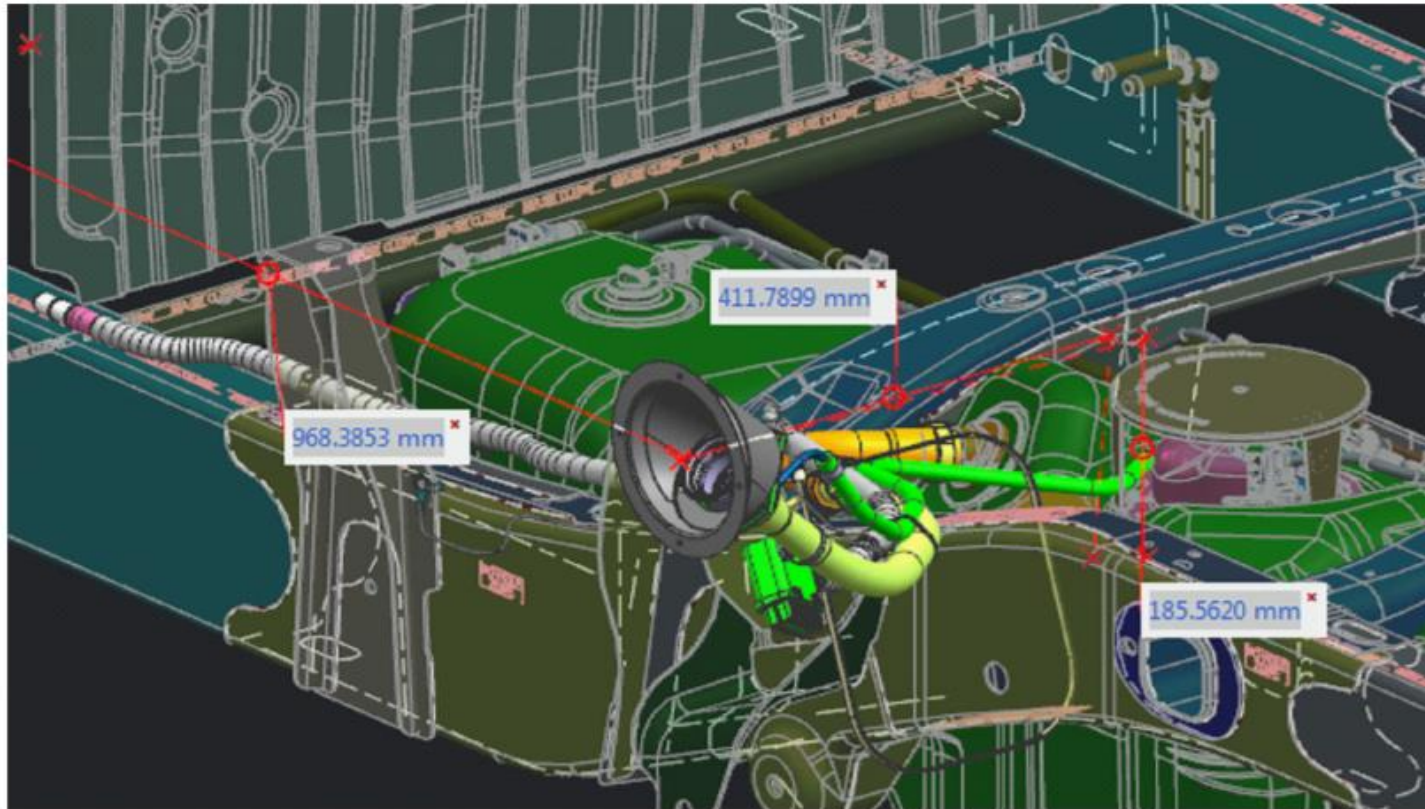

P/N: 84663534 – CK LD 10903 (New Body Style) w/ZW9 Fuel Fill Assembly

Dim. A (Back of Cab)	968.39	(+/-25.4)
Dim. C (Side of Rail)	411.79	(+/-13.0)
Dim. D (Top of Rail)	185.56	(+/-13.0)

C/K LD ZW9/Box Removal PU Fuel Filler

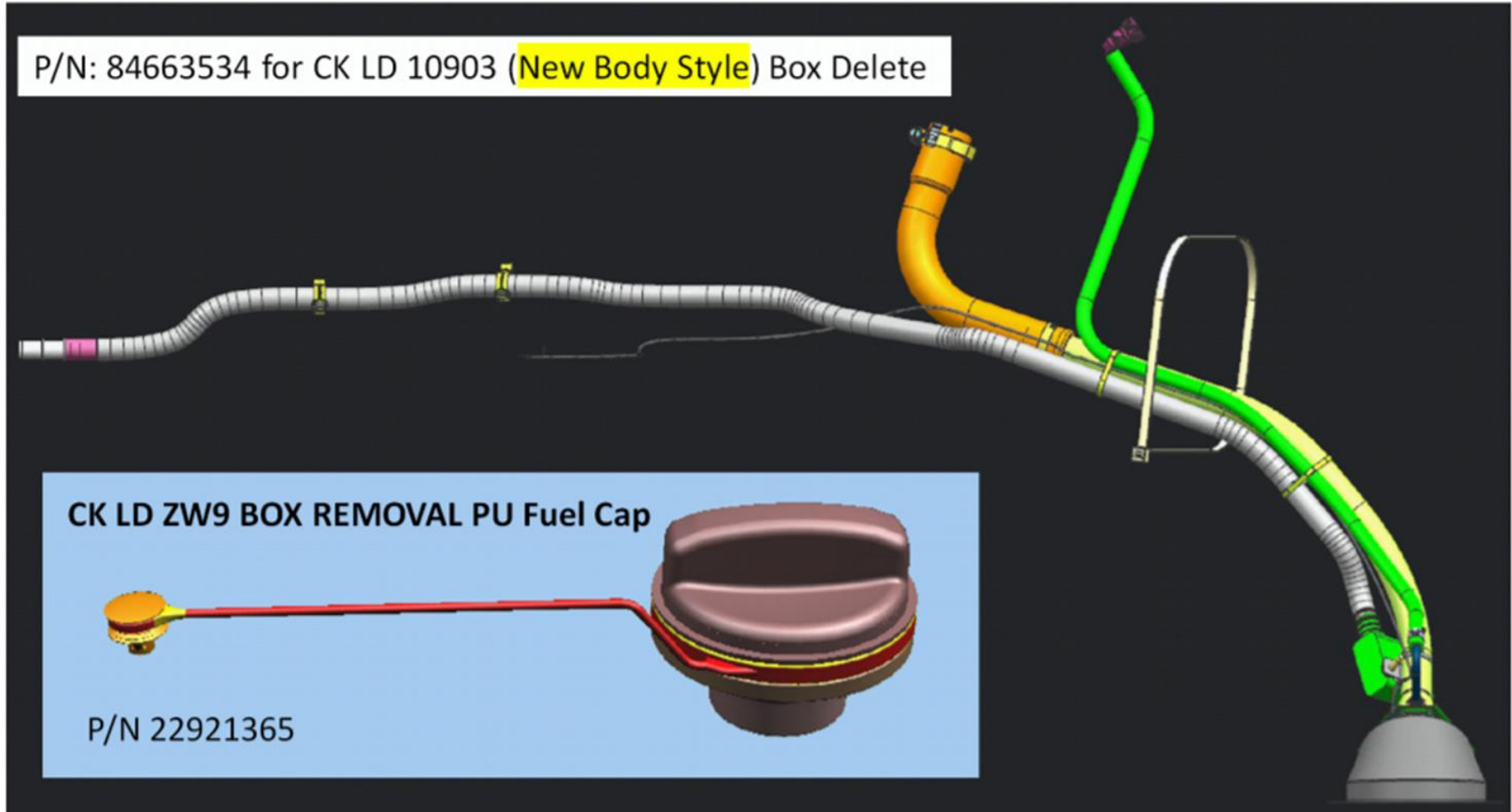

K LD ZW9 Fuel Filler Shipping Location



CK HD ZW9/Box Removal PU Fuel Fillers (Carry-Over Body Style)

Part No.	Description	Series	Body Style	Options
15169365	Hose-Elbow Kit F/Fill	100,200,300	03,43,53	BJA
22774522	Pipe Asm. F/Tank Fill	360,364	03,43	&FHO&N2M/N2N
23114055	Pipe Asm. F/Tank Fill	100,200,300	03,43,53	&FHO&ZW9
22807908	Pipe Asm. F/Tank Fill	359	03,43,53	&E65&FHS-SRW
22788094	Pipe Asm. F/Tank Fill	200,359	00	&FHX&ZW9
22786540	Pipe Asm. F/Tank Fill	360,364	03,43	&FHX&N2M/N2N
22786541	Pipe Asm. F/Tank Fill	360,364	03,43	&FHX&N2L
22774521	Pipe Asm. F/Tank Fill	360,364	03,43	&FHO&N2L

Body Style:

03 Regular Cab, 43 Crew Cab, 53 Extended Cab

Option Key:

FHO-Gas, FH5-E85, FHX-Diesel, ZW9-Box Delete, N2N- Dual Tank (CC), N2L Rear Tank Only (CC), N2m Front Tank Only (CC), BJA-Includes Elbows/Service body usage.

CK HD ZW9/Box Removal PU Fuel Filler (Carry Over Body Style)

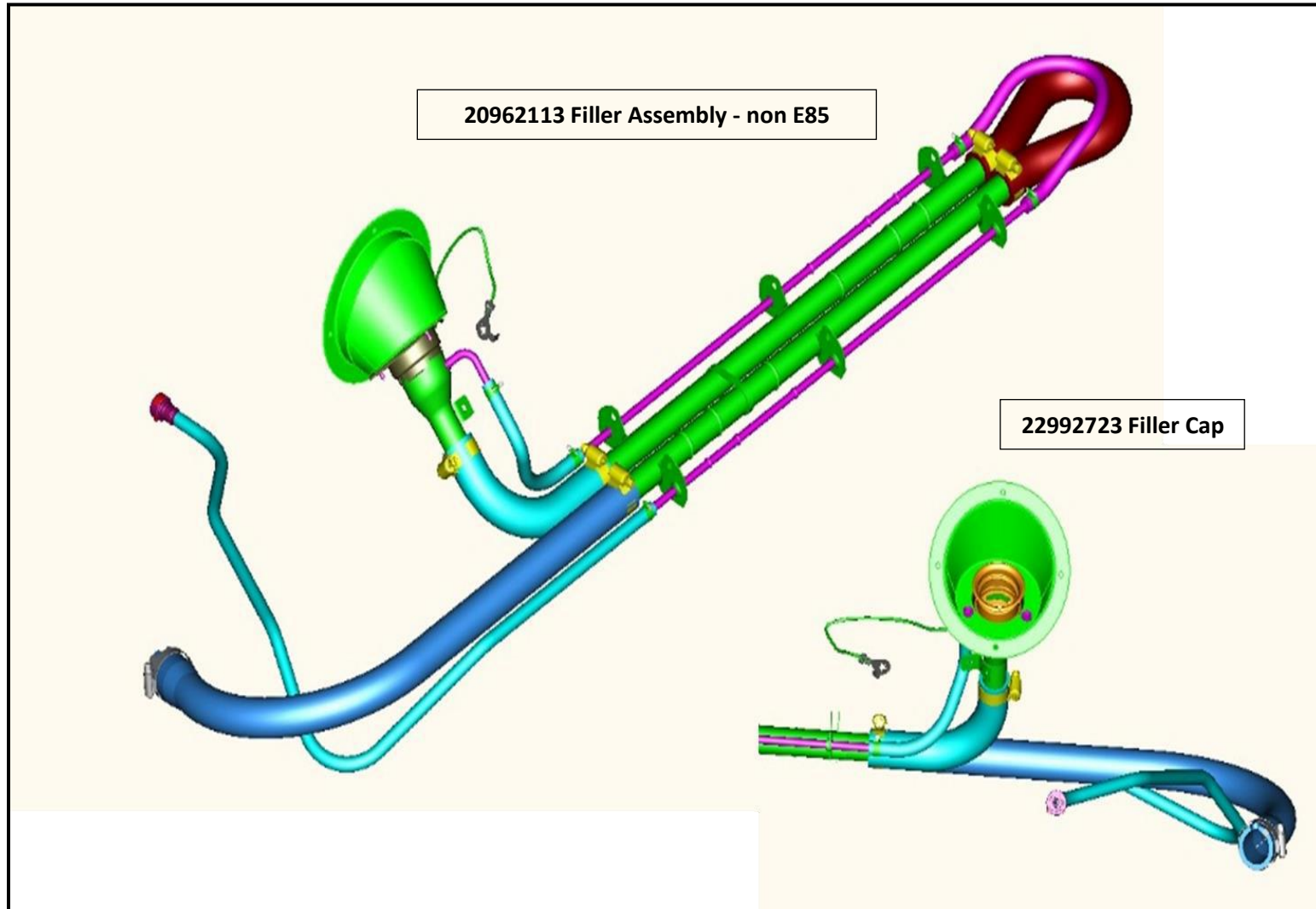

CK HD ZW9 PU Fuel Filler Shipping Location

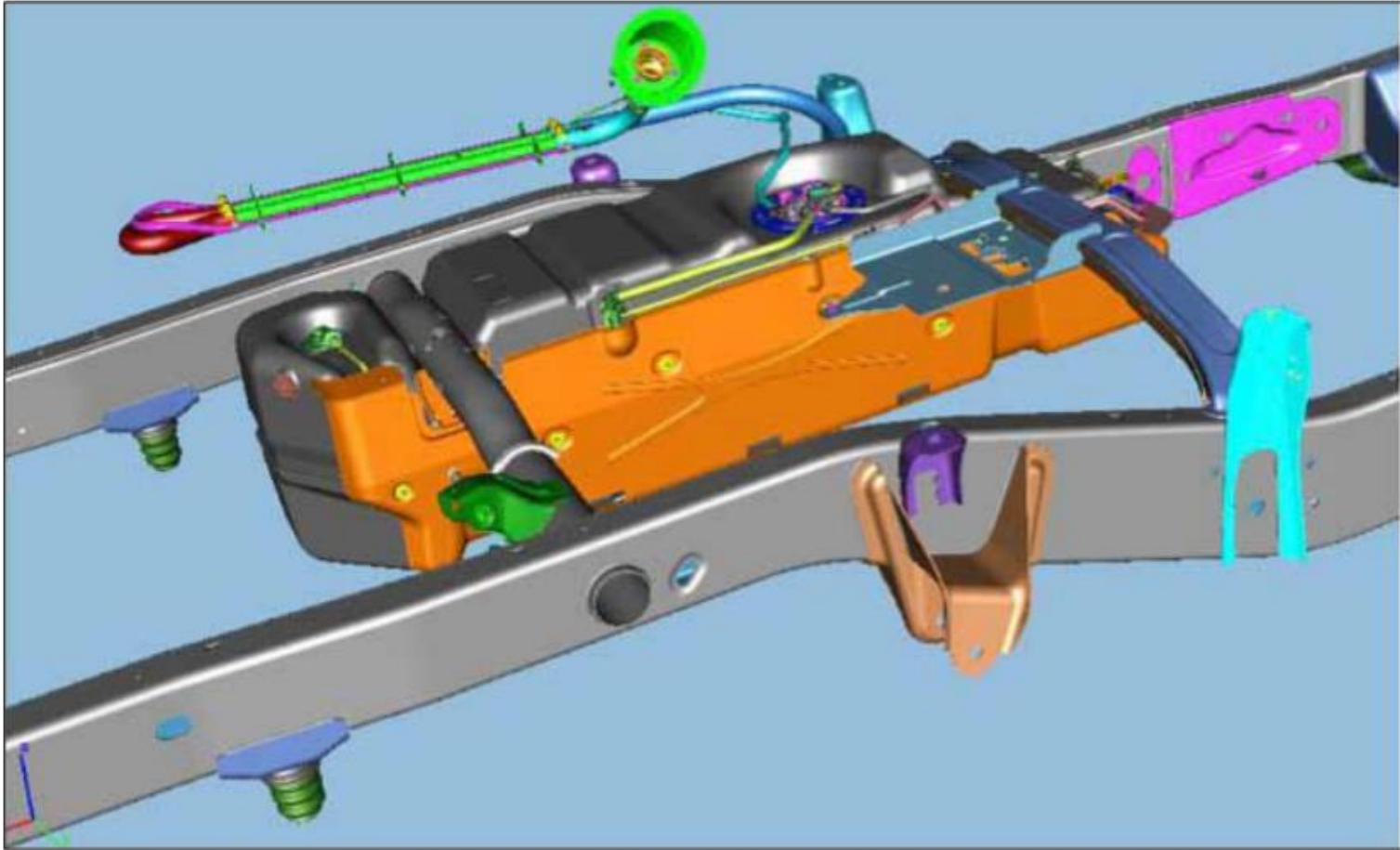

CK HD `Pickup` ZW9/Box Removal DIESEL Fuel Filler Shipping Location (All New Body Style)

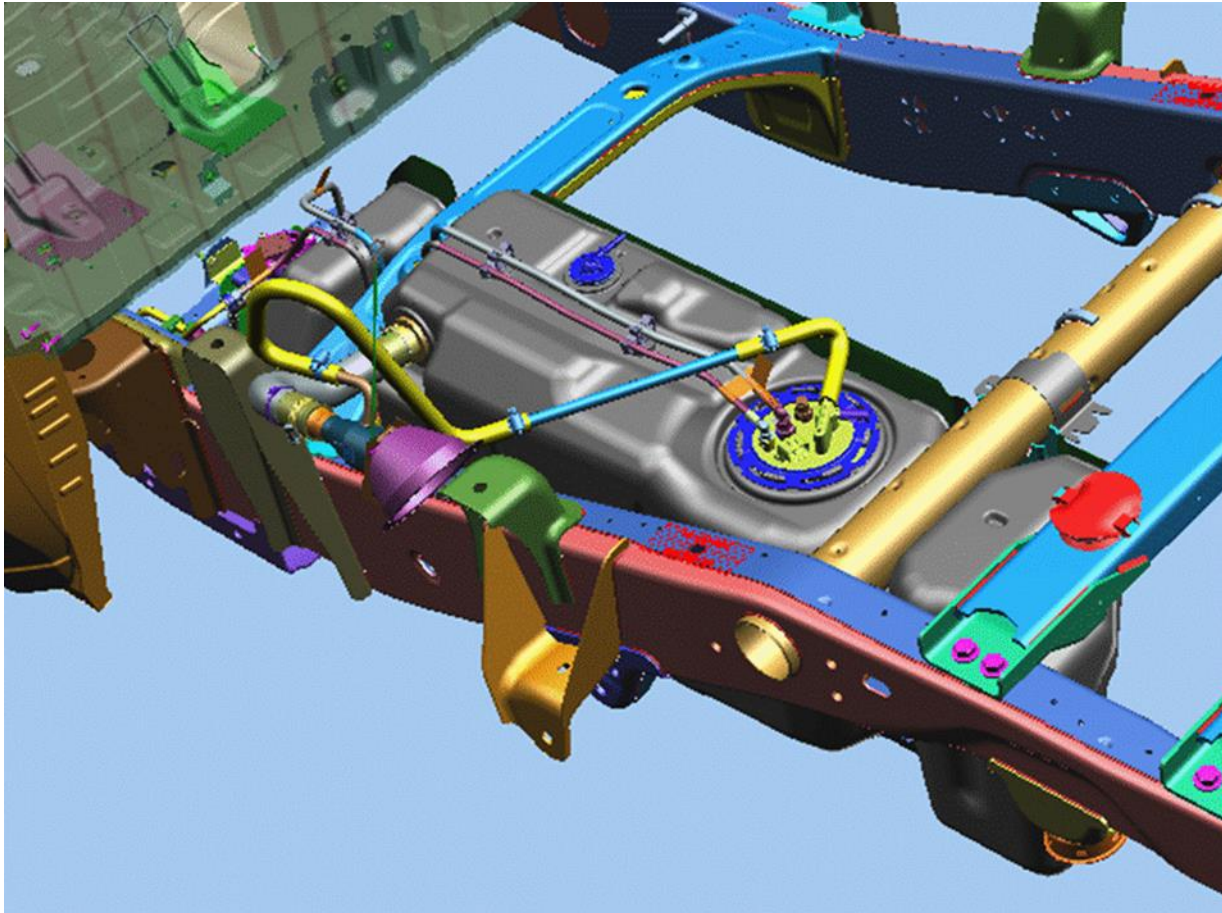

- Shortened Fuel Fill Assembly as delivered from assembly plant. Use `Fuel Filler parts kit` (bag in Cab) to complete upfit body installation.
- Also available through GM Service Parts.
- Follow GM UI BBM Special Application Fuel Filler Installation and Routing recommendations on page PB-6.

CK HD `Pickup` ZW9/Box Removal DIESEL Fuel Filler Positioning (All New Body Style)

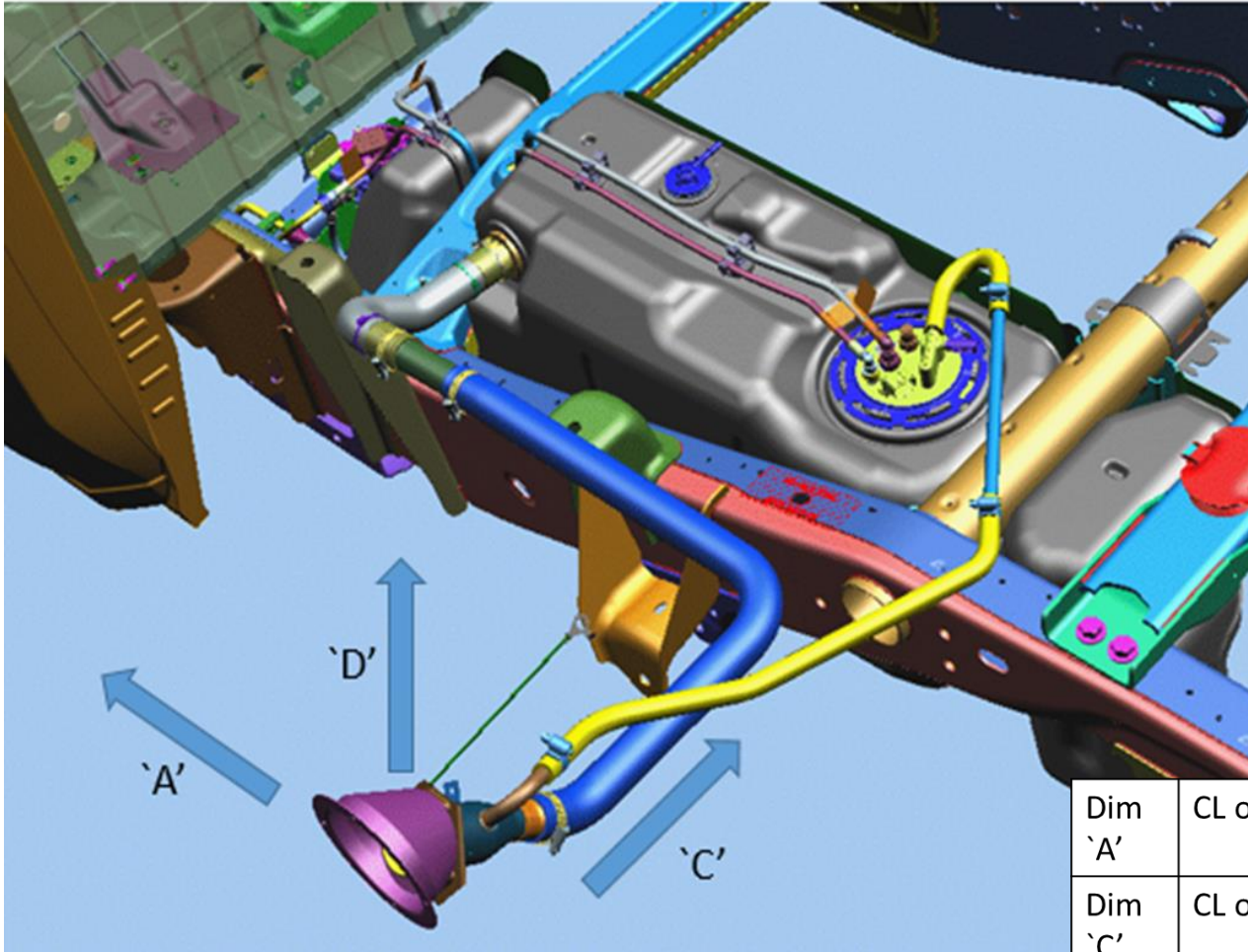

Use `Fuel Filler parts kit` (bag in cab) to complete upfit body installation. Also available through GM Service Parts. Follow GM UI BBM Special Application Fuel Filler Installation and Routing recommendations on page PB-6.

Diesel (FHX) Fill Assembly P/N 84861894

Diesel (FHX) Bag Fill Hose Kit P/N 84818644

Diesel (FHX) Cap P/N 20971566

Dim `A`	CL of Fill to Back of Cab	985.15	+/- 25mm
Dim `C`	CL of Fill to Outside Rail	640.67	+/- 13mm
Dim `D`	CL of Fill to Top of Rail	208.69	+/- 13mm

CK HD `Pickup` ZW9/Box Removal GAS Fuel Filler Shipping Location (All New Body Style)

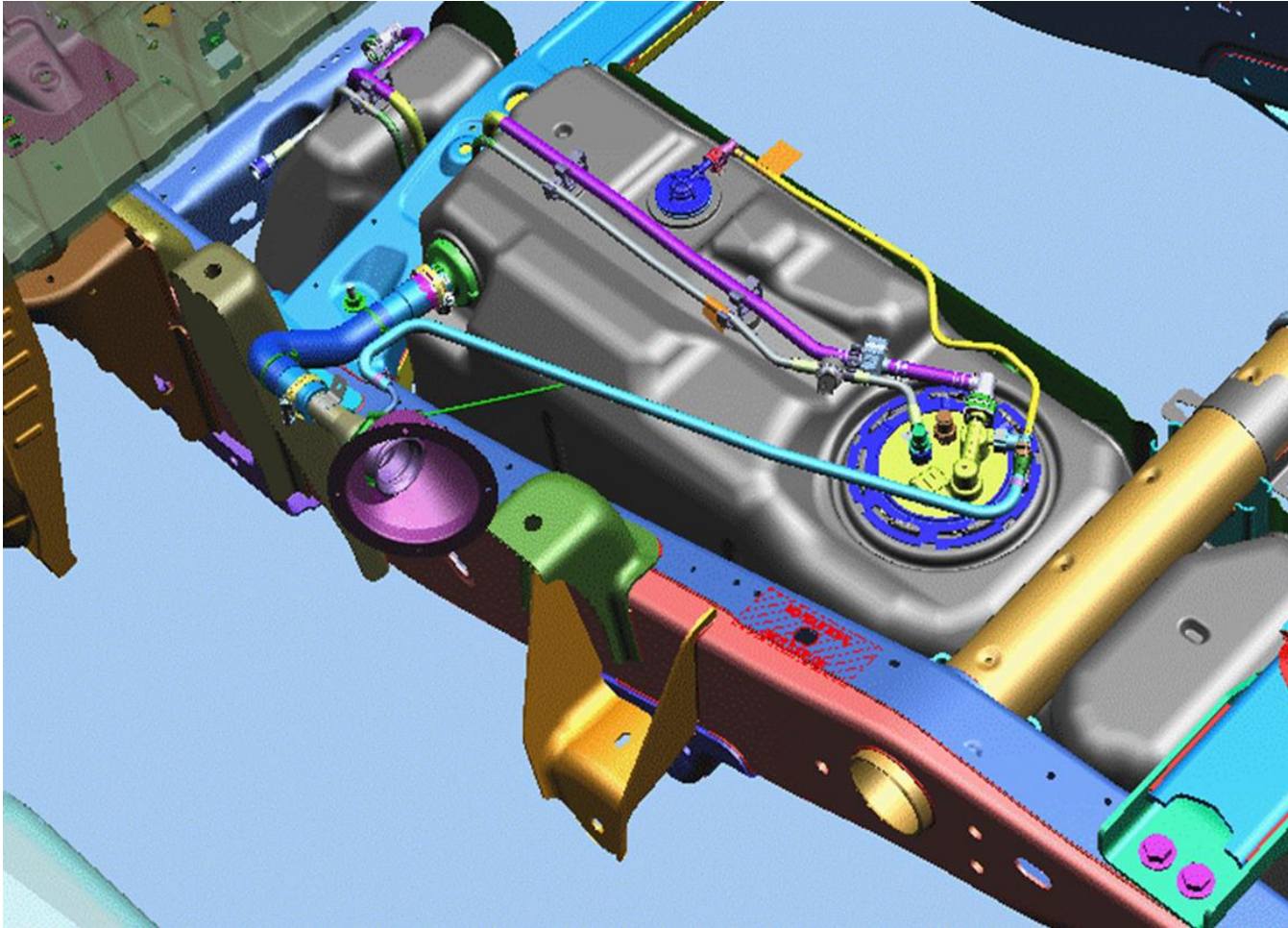

Shortened Fuel Fill Assembly as delivered from assembly plant. Use `Fuel Filler parts kit` (bag in Cab) to complete upfit body installation. Also available through GM Service Parts.

Follow GM UI BBM Special Application Fuel Filler Installation and Routing recommendations on page PB-6.

CK HD `Pickup` ZW9/Box Removal GAS Fuel Filler Positioning (All New Body Style)

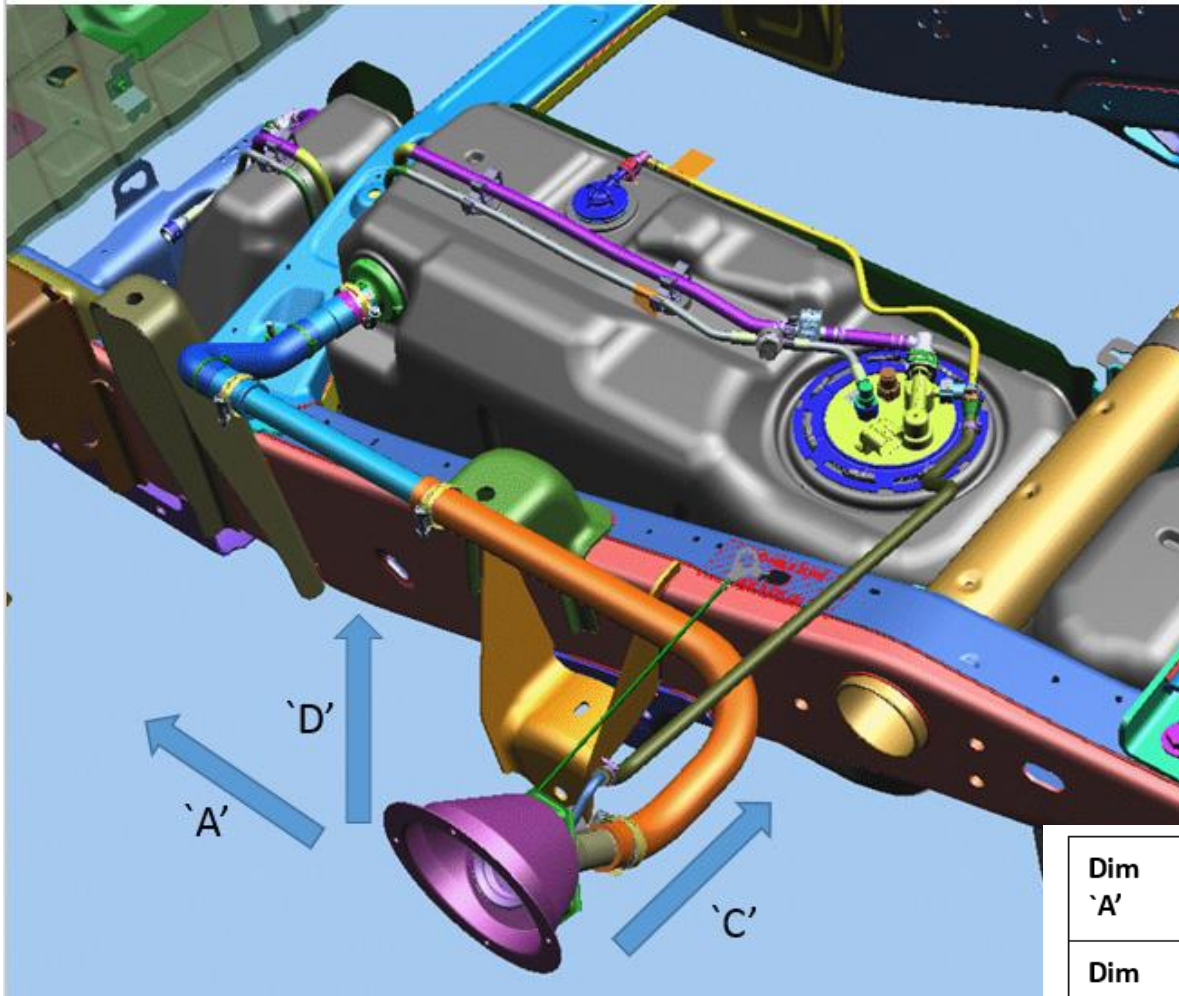

Use `Fuel Filler parts kit` (bag in Cab) to complete upfit body installation. Also available through GM Service Parts.

Follow GM UI BBM Special Application Fuel Filler Installation and Routing recommendations on page PB-6.

Gas (FJW) Fill Assembly P/N 84709155

Gas (FJW) Bag Fill Hose Kit P/N 84818645

Gas (FJW) Cap P/N 22921365

Dim `A`	CL of Fill to Back of Cab	985.15	+/- 25mm
Dim `C`	CL of Fill to Outside Rail	640.67	+/- 13mm
Dim `D`	CL of Fill to Top of Rail	208.69	+/- 13mm

CK HD `Cab Chassis' ZW9 DIESEL Fuel Filler Shipping Location (All New Body Style)

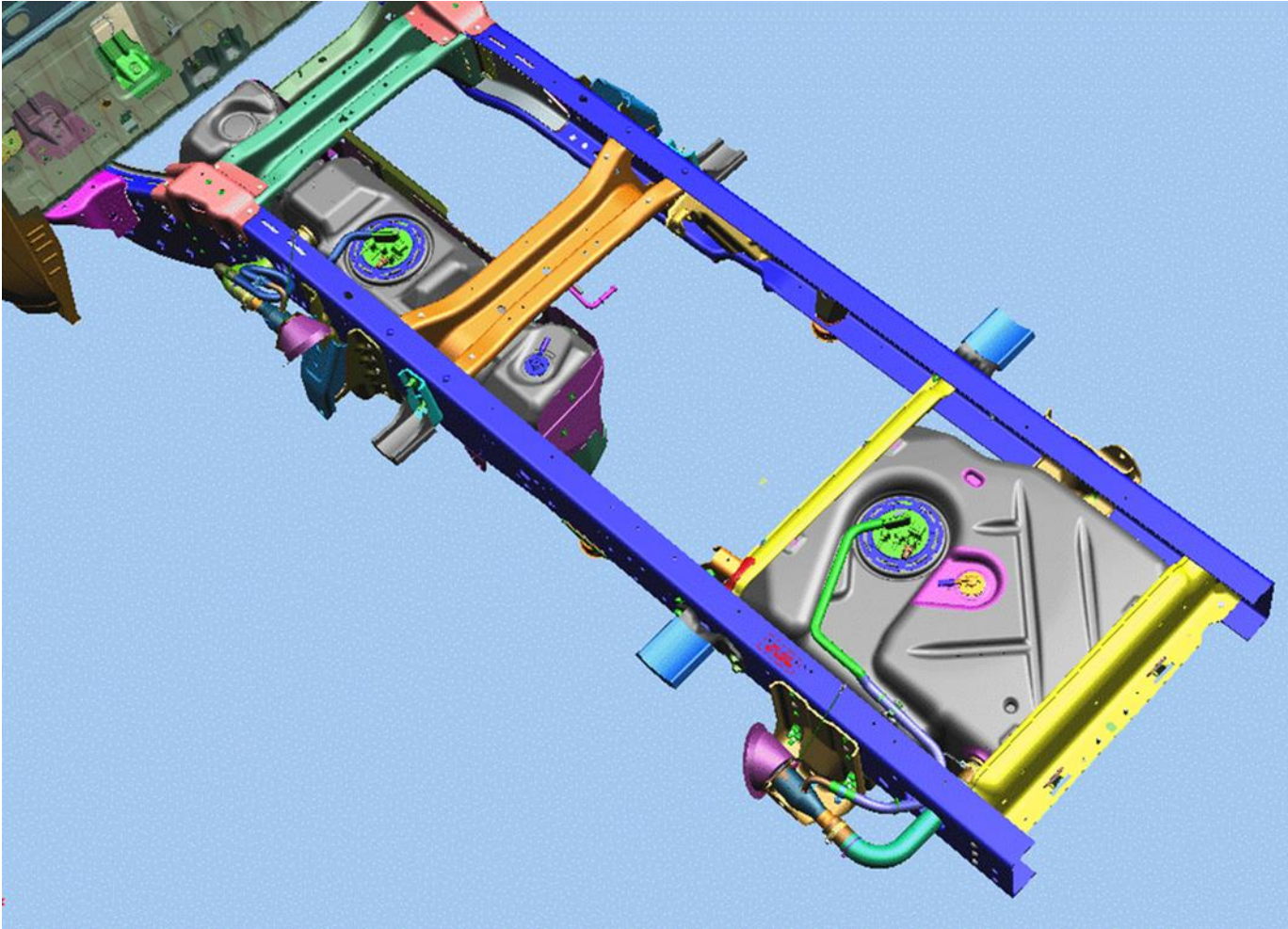

Shortened Fuel Fill Assembly as delivered from assembly plant. Use `Fuel Filler parts kit' (bag in Cab) to complete upfit body installation. Also available through GM Service Parts.

Follow GM UI BBM Special Application Fuel Filler Installation and Routing recommendations on page PB-6.

CK HD `Cab Chassis` ZW9 DIESEL Fuel Filler Positioning (All New Body Style)

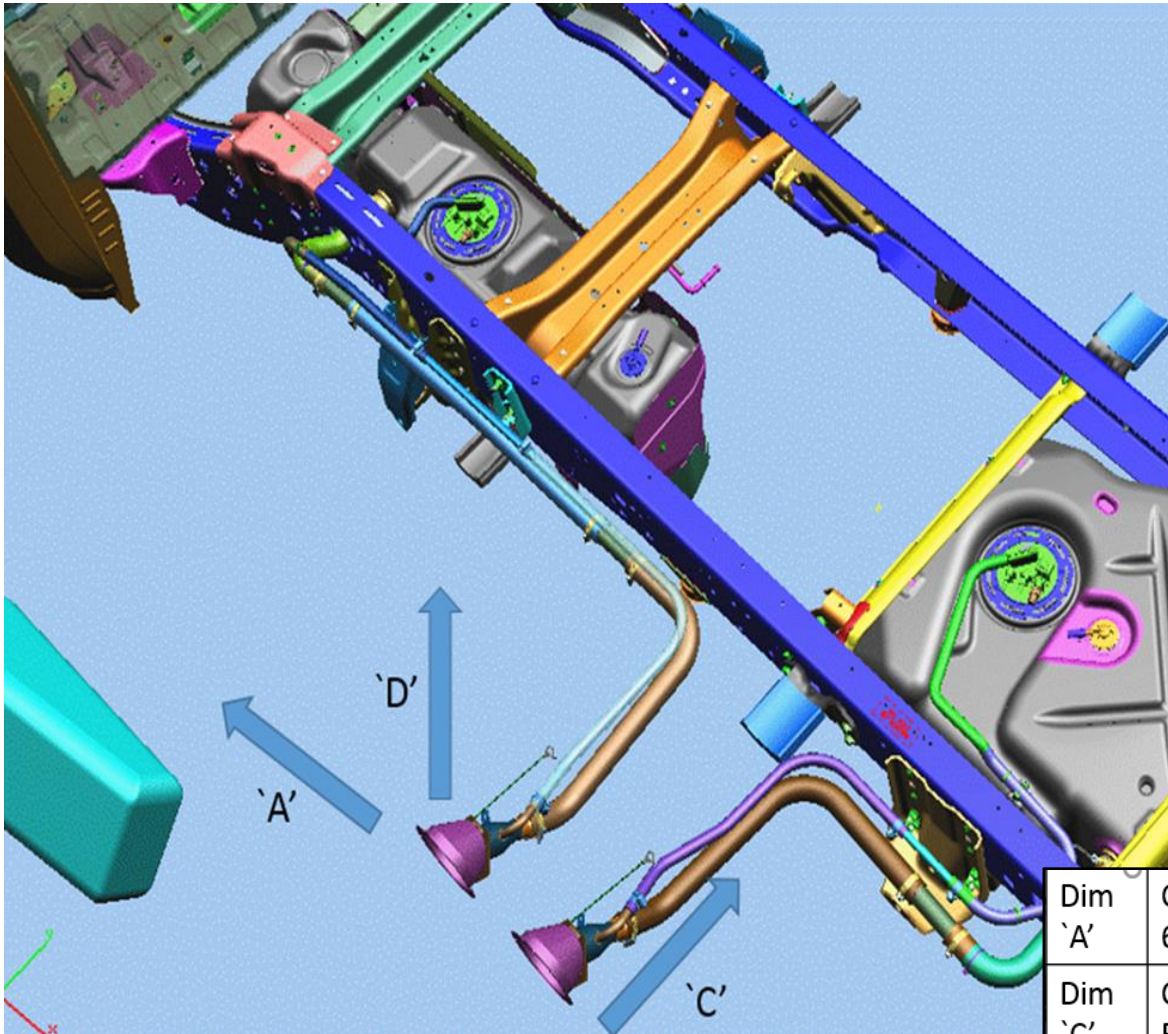

Use `Fuel Filler parts kit` (bag in Cab) to complete upfit body installation. Also available through GM Service Parts.

Follow GM UI BBM Special Application Fuel Filler Installation and Routing recommendations on page PB-6.

Diesel (FHX) Front Fill Assembly P/N 84861898

Diesel (FHX) Bag Fill Hose Kit P/N 84818648

Diesel (FHX) Rear Fill Assembly P/N 84861896

Diesel (FHX) Bag Fill Hose Kit P/N 84818649

Diesel (FHX) Cap P/N 20971566

Dim `A`	CL of Fill to Back of Cab 60"CA(-24.5")/ 84"CA	/1894.25 Frt /2784.85 Rr	+/- 25mm
Dim `C`	CL of Fill to Outside Rail	700.24 Frt 700.24 Rr	+/- 13mm
Dim `D`	CL of Fill to Top of Rail	194.58 Frt 194.58 Rr	+/- 13mm

CK HD `Cab Chassis' ZW9 GAS Fuel Filler Shipping Location (All New Body Style)

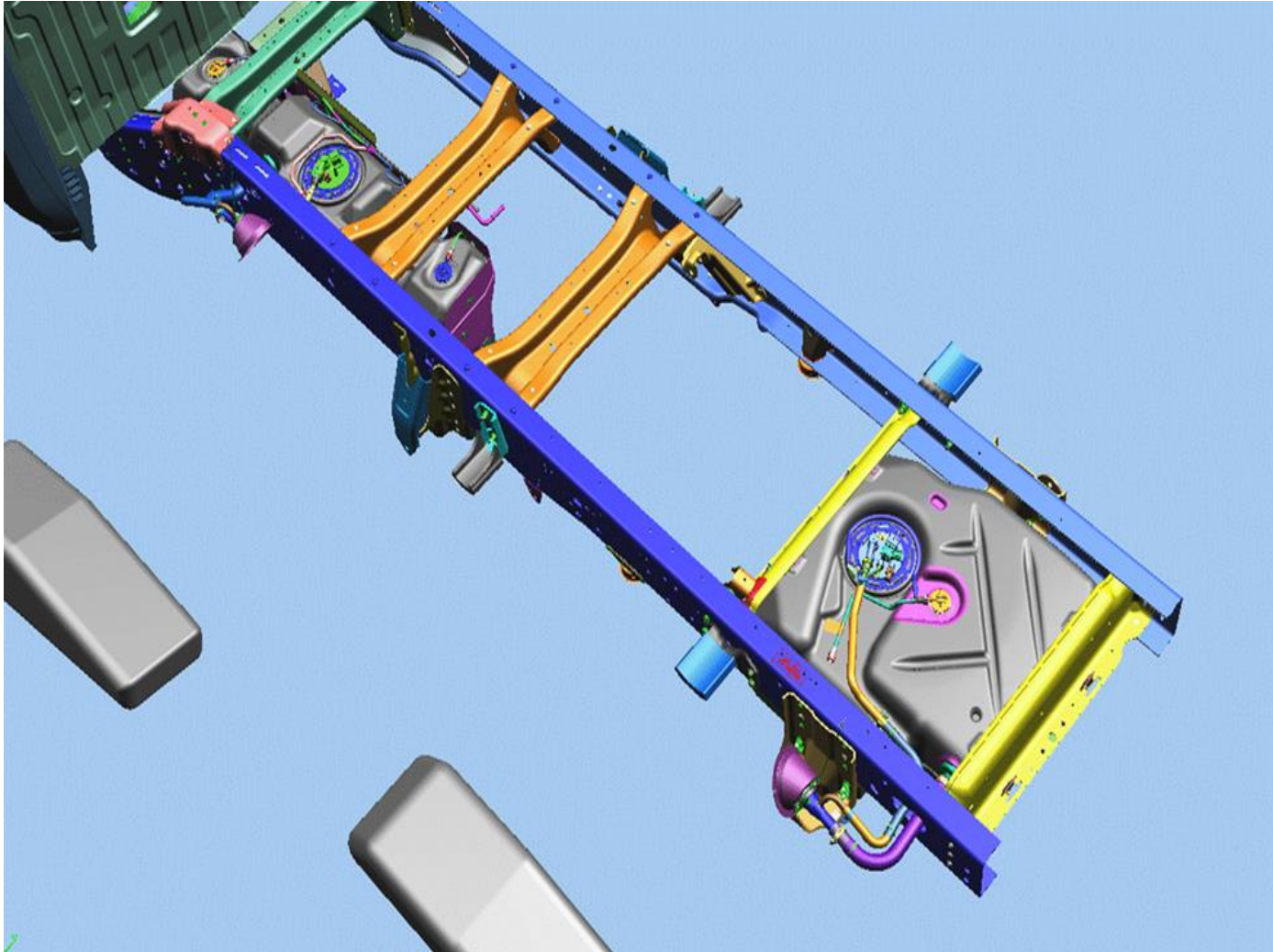

Shortened Fuel Fill Assembly as delivered from assembly plant. Use `Fuel Filler parts kit' (bag in Cab) to complete upfit body installation. Also available through GM Service Parts.

Follow GM UI BBM Special Application Fuel Filler Installation and Routing recommendations on page PB-6.

CK HD `Cab Chassis` ZW9 GAS Fuel Filler Positioning (All New Body Style)

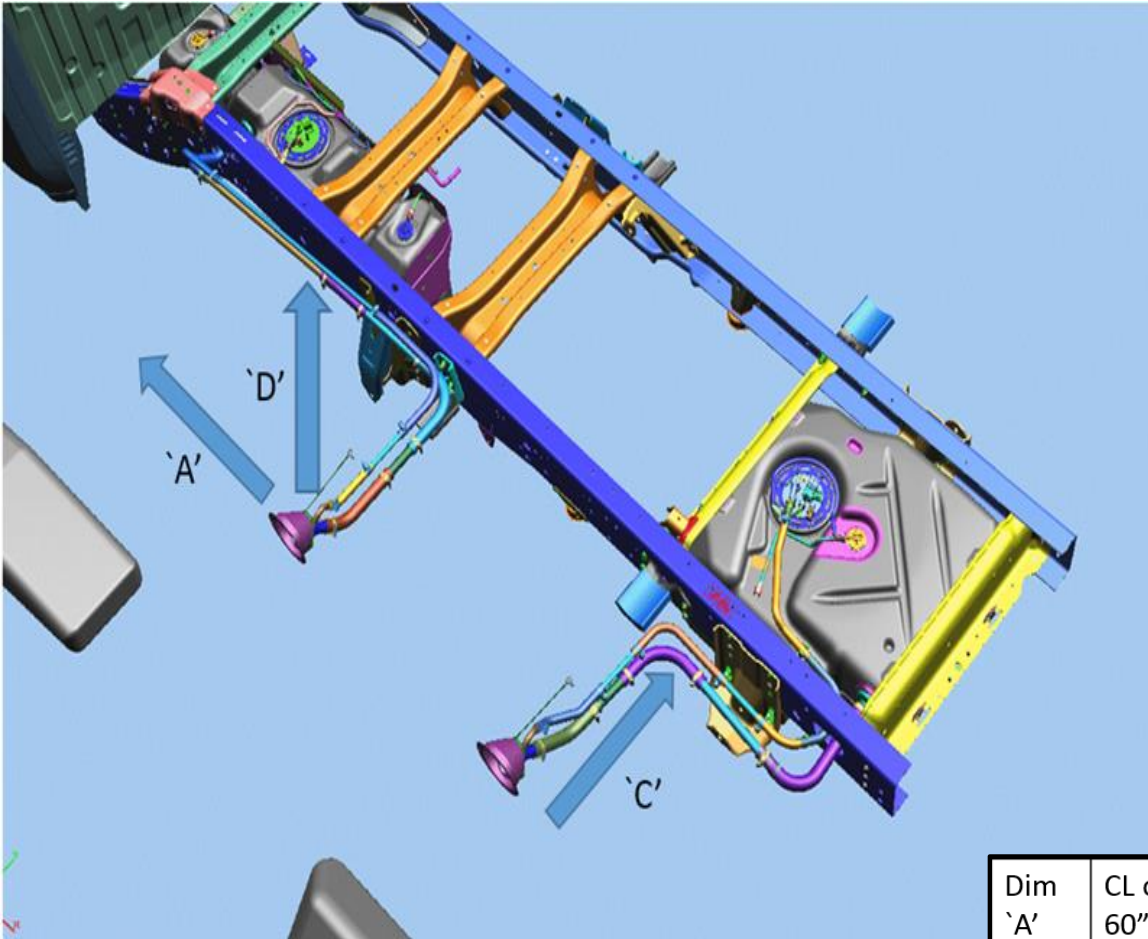

Shortened Fuel Fill Assemblies as delivered from assembly plant. Use `Fuel Filler parts kit'(bag in Cab) to complete upfit body installation. Also available through GM Service Parts.

Follow GM UI BBM Special Application Fuel Filler Installation and Routing recommendations on page PB-6.

- Gas (FJW) Front Single Fill Assembly P/N 84822390
- Gas (FJW) Front Dual Tank Fill Assembly P/N 84822391
- Gas (FJW) Front Bag Fill Hose Kit P/N 84818646
- Gas (FJW) Rear Fill Assembly P/N 84709156
- Gas (FJW) Rear Bag Fill Hose Kit P/N 84818647
- Gas (FJW) Cap P/N 22921365

Dim `A`	CL of Fill to Back of Cab 60"CA(-24.5")/ 84"CA	/1894.25 Frt /2784.85 Rr	+/- 25mm
Dim `C`	CL of Fill to Outside Rail	700.24 Frt 700.24 Rr	+/- 13mm
Dim `D`	CL of Fill to Top of Rail	194.58 Frt 194.58 Rr	+/- 13mm

CK HD ZW9 Cab Chassis Filler/Upfit Body Attachment

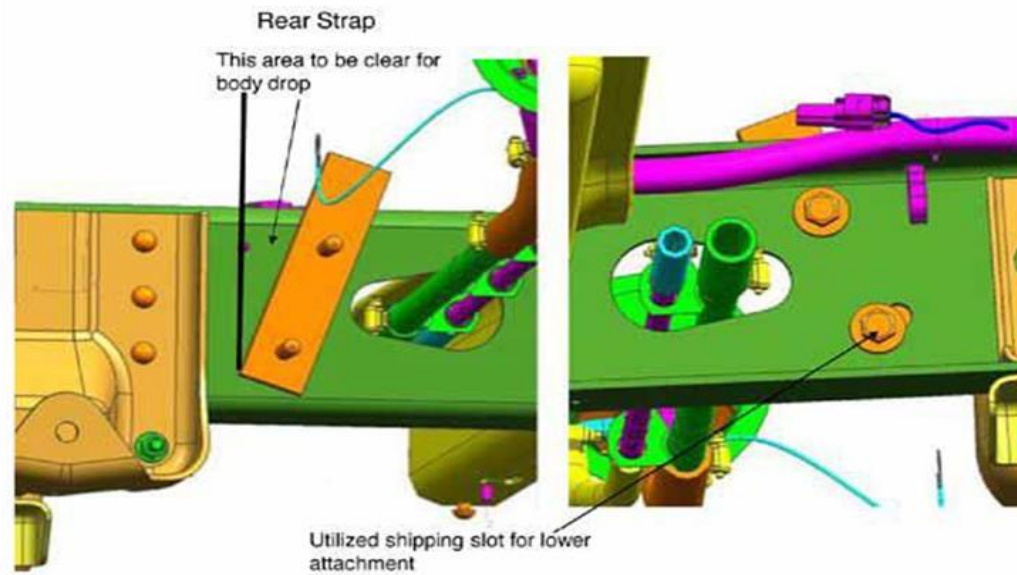
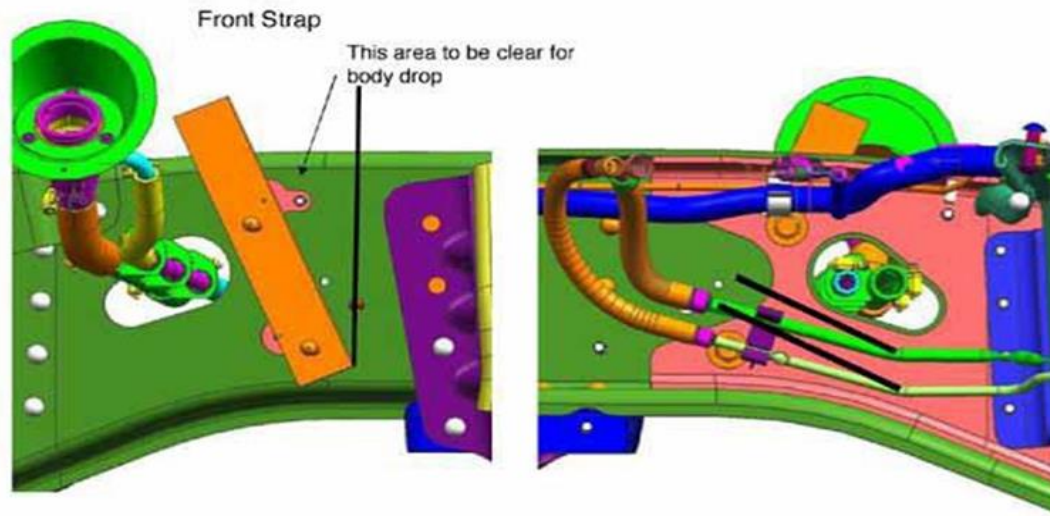

CK LD/HD ZW9 Gas Vapor Sensor (Shipped Loose)

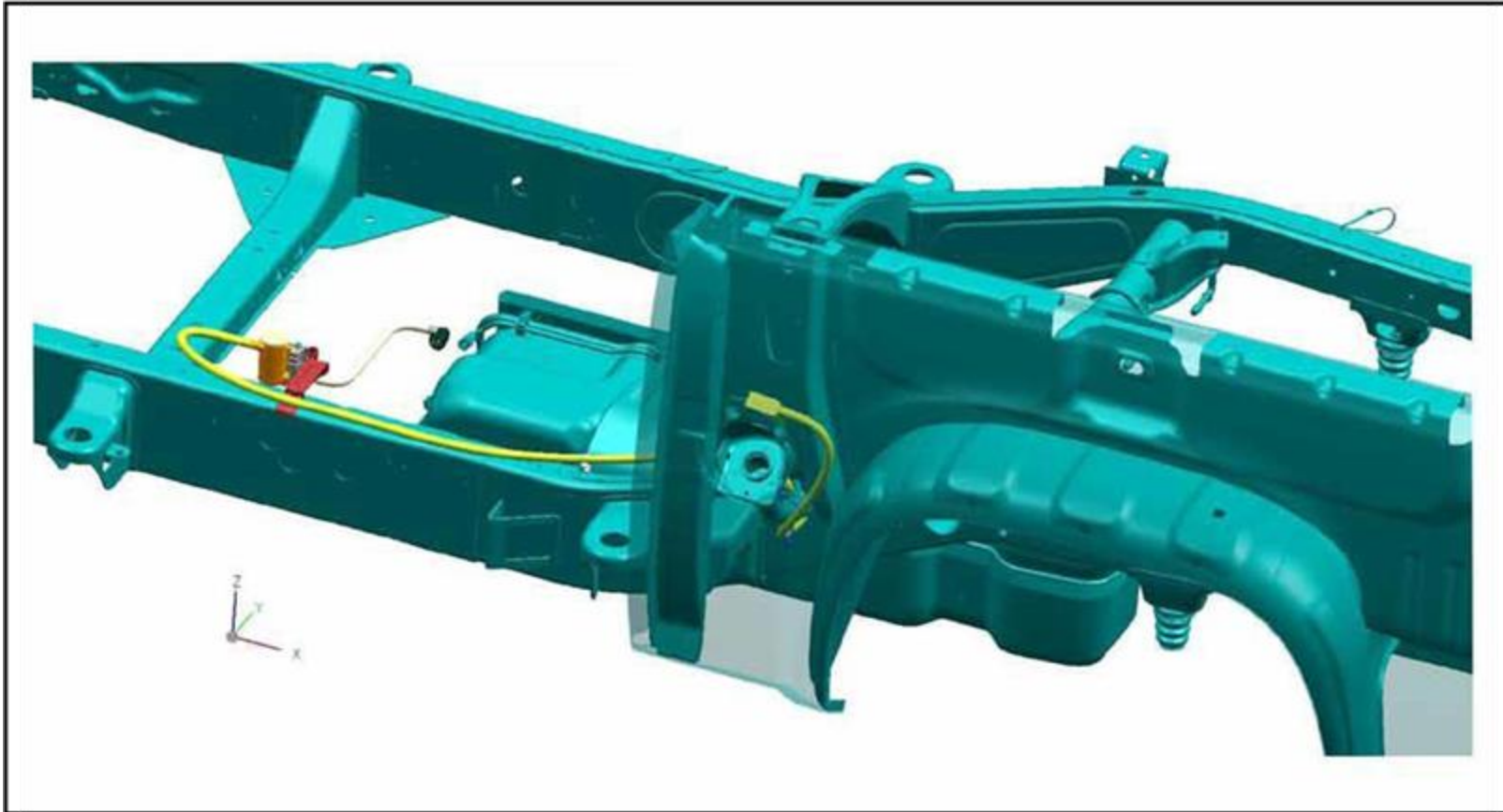

Note:

Gas Models require Upfitter to permanently mount Vapor Pressure Sensor Unit in a sheltered environment. Sensor wire harness should also be secured properly. Harness and Sensor should be clear of moving and or heat generating chassis components.

CK HD ZW9 rear axle vent shipping location

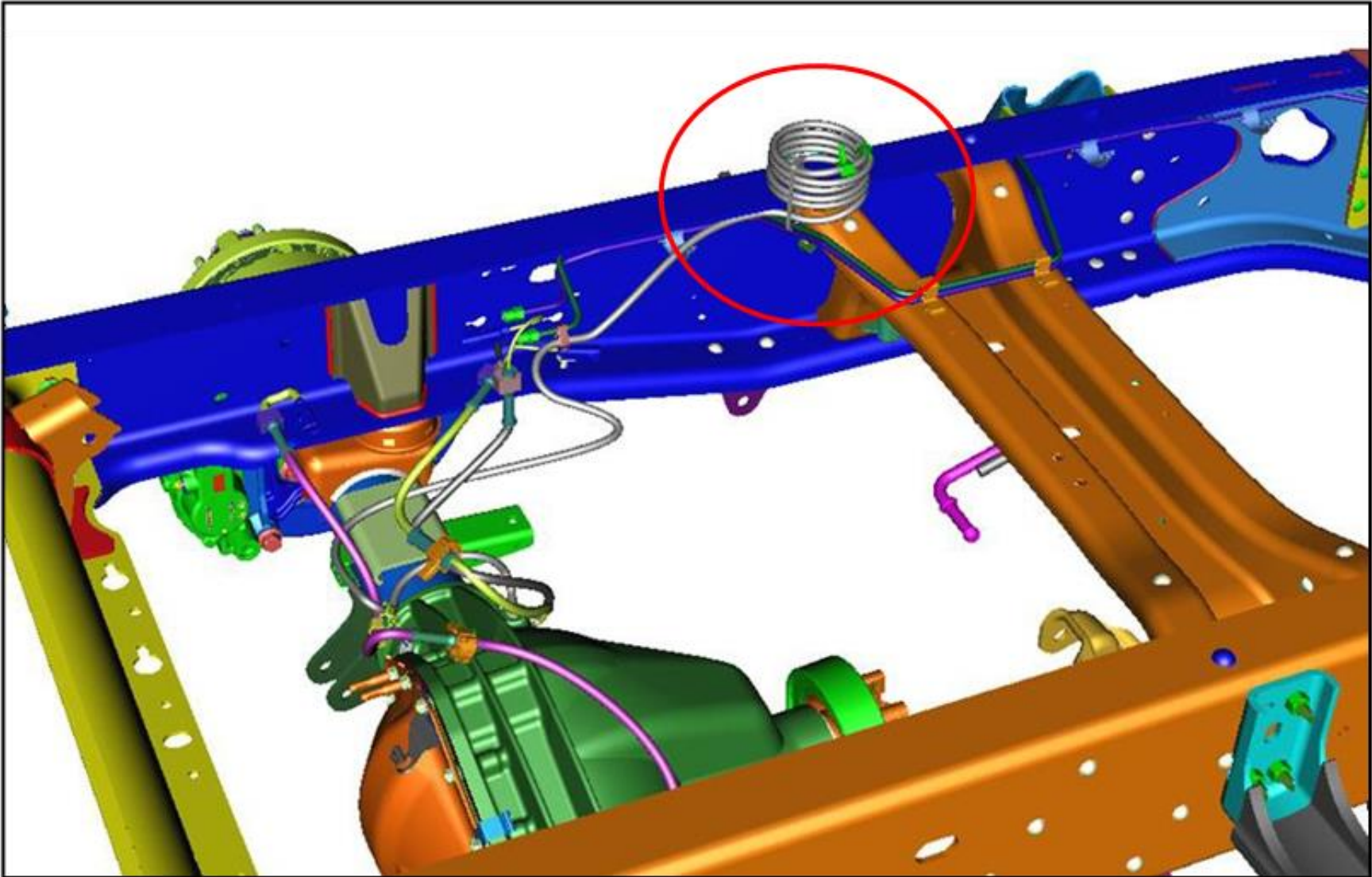

CK HD ZW9 rear axle vent attachment

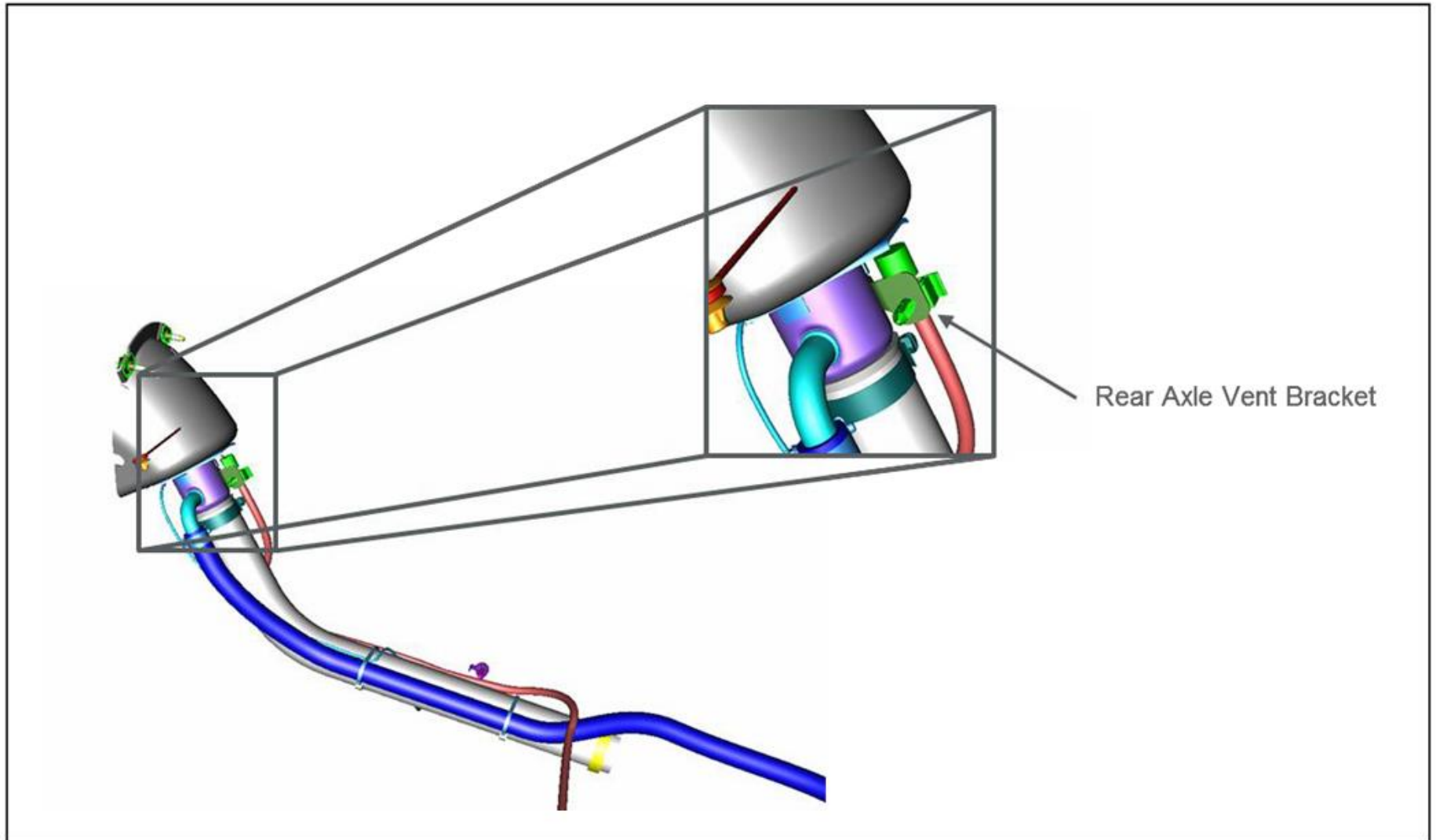

* Note: The Final Stage Manufacturer must evaluate the Vent Hose location per their specification to ensure proper function. Relocation / orientation and / or shielding may be required.

CK HD `Pickup` ZW9/Box Removal DEF Tank & Fill `In the Gap` Positioning (All New Body Style)

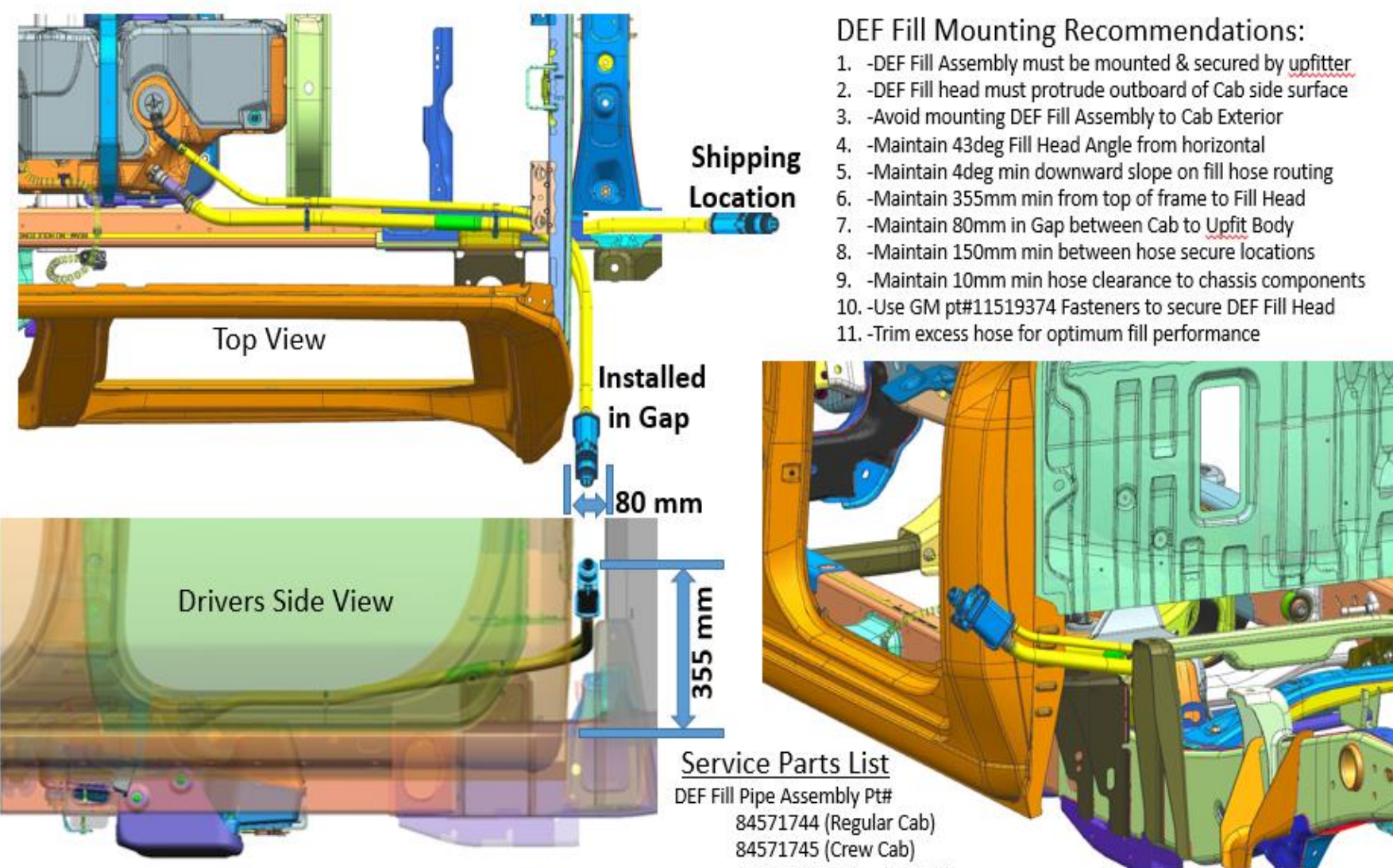

Shipping Location

Top View

Installed in Gap

80 mm

355 mm

Drivers Side View

DEF Fill Mounting Recommendations:

1. -DEF Fill Assembly must be mounted & secured by upfitter
2. -DEF Fill head must protrude outboard of Cab side surface
3. -Avoid mounting DEF Fill Assembly to Cab Exterior
4. -Maintain 43deg Fill Head Angle from horizontal
5. -Maintain 4deg min downward slope on fill hose routing
6. -Maintain 355mm min from top of frame to Fill Head
7. -Maintain 80mm in Gap between Cab to Upfit Body
8. -Maintain 150mm min between hose secure locations
9. -Maintain 10mm min hose clearance to chassis components
10. -Use GM pt#11519374 Fasteners to secure DEF Fill Head
11. -Trim excess hose for optimum fill performance

Service Parts List

- DEF Fill Pipe Assembly Pt#
 - 84571744 (Regular Cab)
 - 84571745 (Crew Cab)
 - 84579127 (Extended Cab)
- DEF Cap – Pt# 23138955

CK HD `Cab Chassis` ZW9 DEF Tank Outboard Frame Rail Location (All New Body Style)

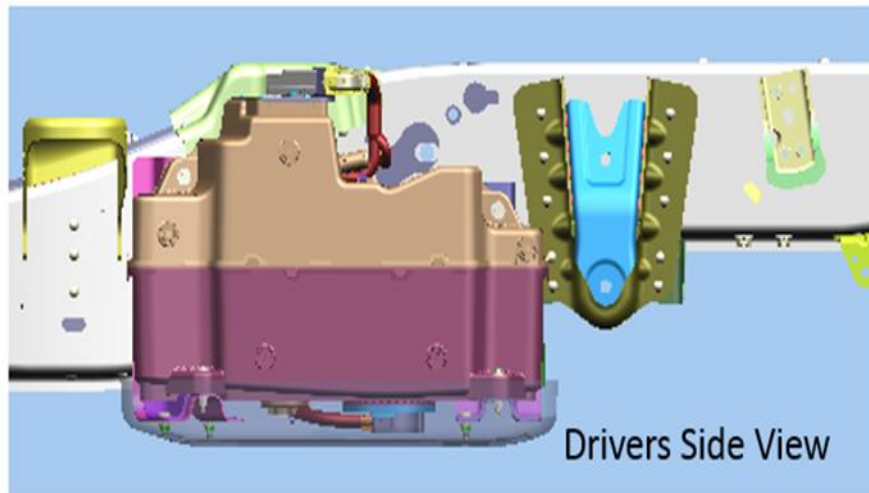

DEF Tank shown in factory built outboard frame rail location. Compatible with all fuel tank options RPO-N2N(dual),N2M(front), N2L(rear).

See Special Apps page for DEF Fill routing and location info.

Service Parts List

1. Supply Line Assembly (31403/31003) – 84590626
2. Supply Line Assembly (31043) – 84590627
3. Fill Pipe Assembly – 84605515
4. Fill Pipe Cap - 23138955

CK HD `Cab Chassis` ZW9 DEF Tank Inboard Frame Rail Relocation (All New Body Style)

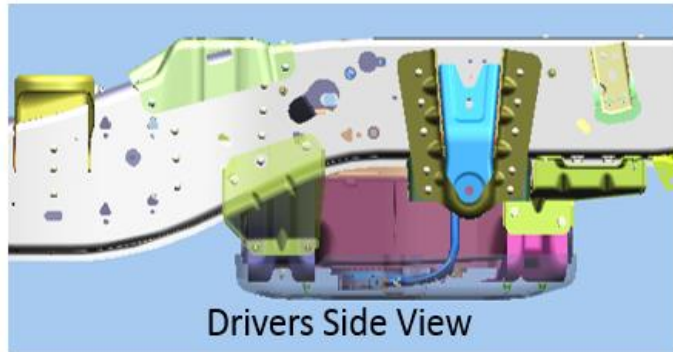
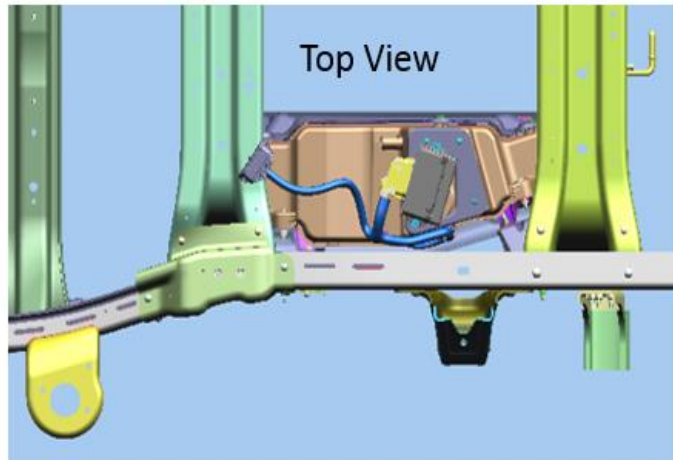

DEF Tank upfitter relocated for `Service Body` type applications to Inboard rail position. Compatible with RPO-N2L `Rear Fuel Tank` only applications. Use included `DEF Tank relocation parts kit` (bag in Cab) when RPO-N2L(Diesel) is ordered. Also available through GM Service Parts.

Follow GM UI UI Bulletin #XXX for step-by-step DEF Tank Relocation instruction.

GM Service Parts List

1. Supply Line Assembly (31403/31003) – 84590626
2. Supply Line Assembly (31043) – 84590627
3. Fill Pipe Assembly – 84605515
4. Fill Pipe Cap - 23138955

CK HD `Cab Chassis` ZW9 DEF Tank Inboard Frame Rail Relocation Kit (All New Body Style)

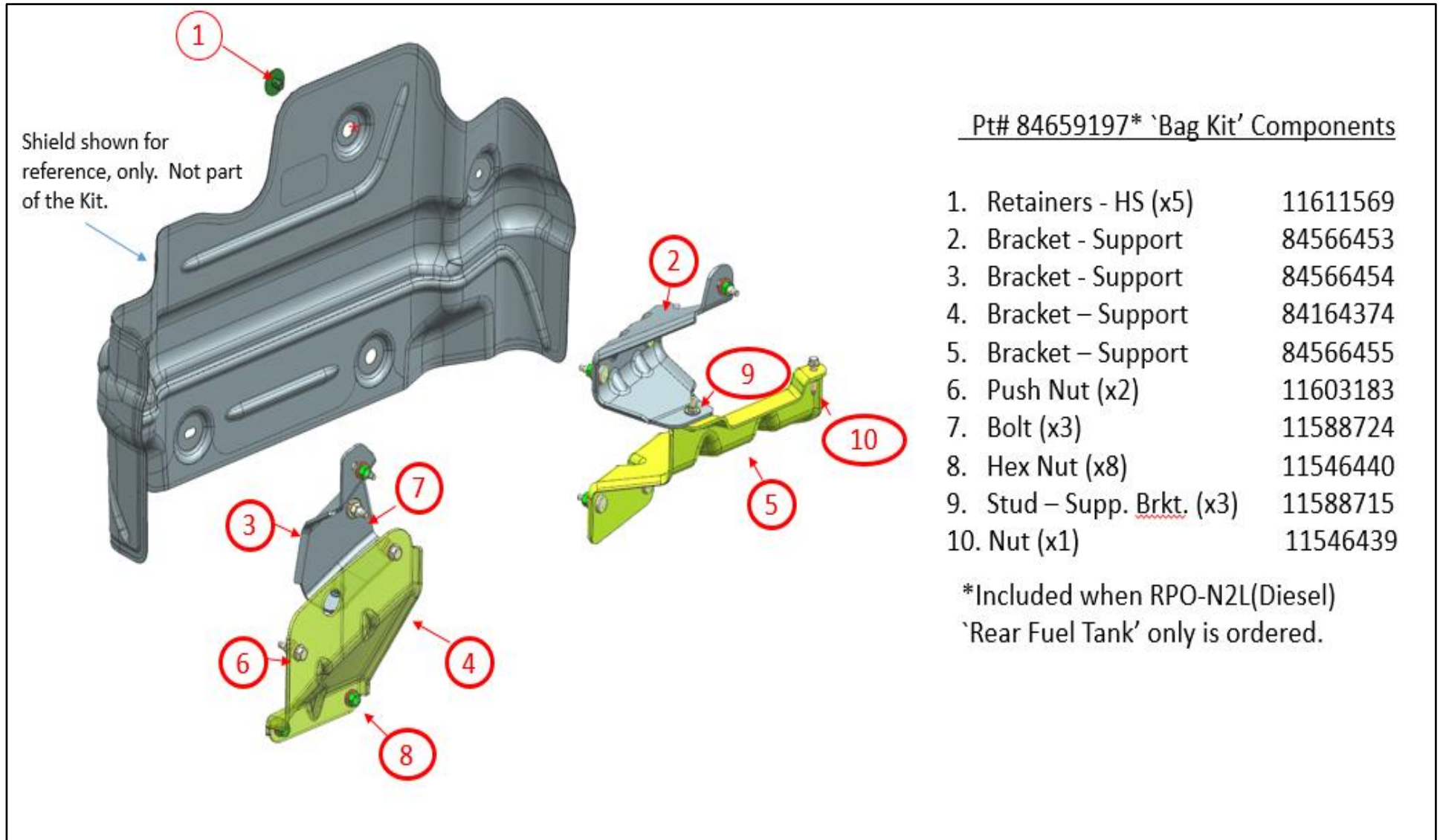

CK HD `Cab Chassis` ZW9 DEF Tank Fill `In the Gap` Positioning (All New Body Style)

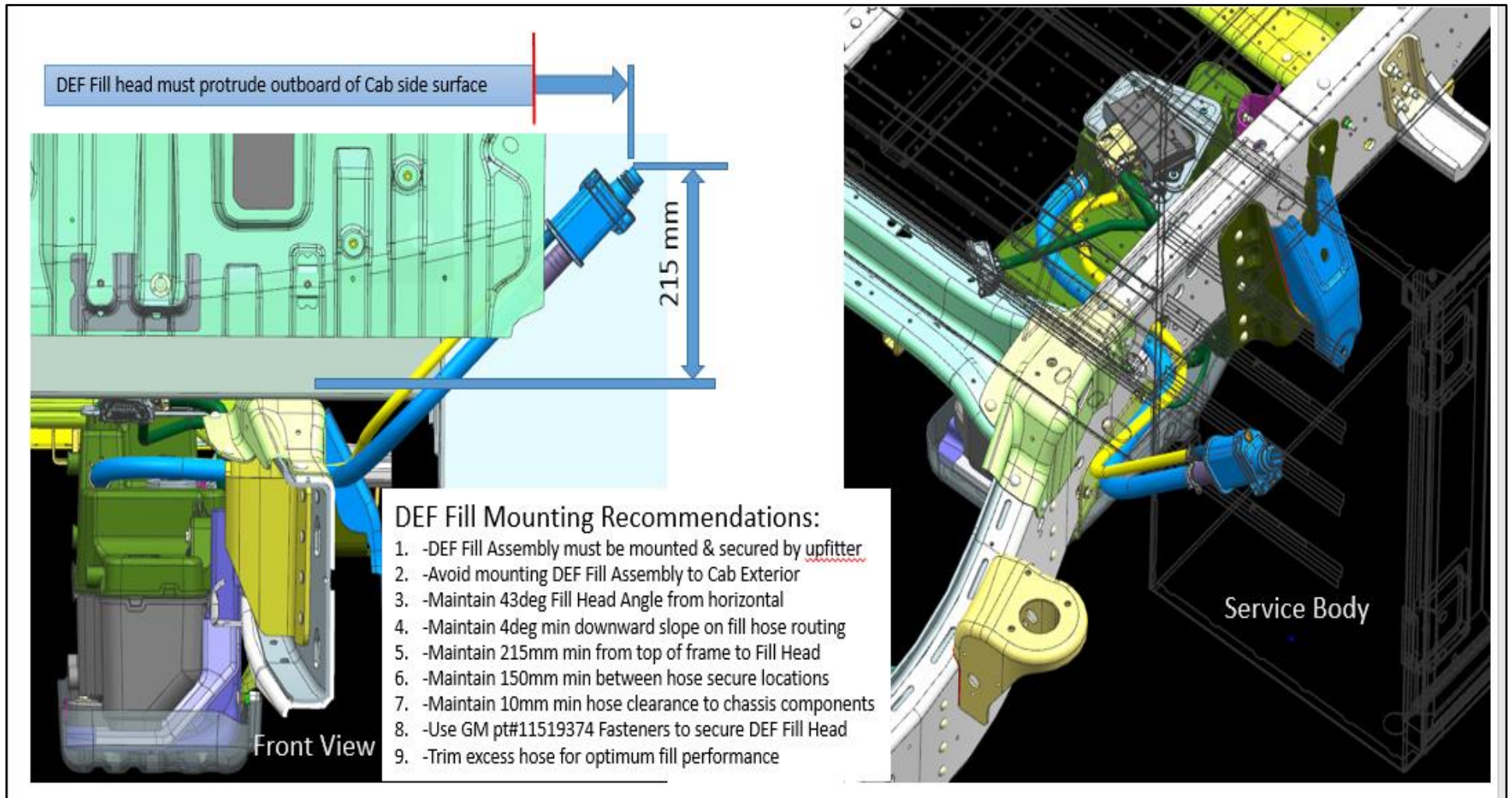

CK HD `Cab Chassis` ZW9 DEF Tank Fill `Wheel House` Positioning (All New Body Style)

DEF Fill Mounting Recommendations:

1. -DEF Fill Assembly must be mounted & secured by upfitter
2. -Avoid mounting DEF Fill Assembly to Cab Exterior
3. -Maintain 43deg Fill Head Angle from horizontal
4. -Maintain 4deg min downward slope on fill hose routing
5. -Maintain 215mm min from top of frame to Fill Head
6. -Maintain 150mm min between hose secure locations
7. -Maintain 10mm min hose clearance to chassis components
8. -Use GM pt#11519374 Fasteners to secure DEF Fill Head
9. -Trim excess hose for optimum fill performance

