

# Table of Contents

<b>General Information</b> .....	<a href="#">1-1</a>	<b>HVAC</b> .....	<a href="#">5-1</a>
General Information .....	<a href="#">1-3</a>	Heating, Ventilation, and Air Conditioning .....	<a href="#">5-3</a>
<b>Body Systems</b> .....	<a href="#">2-1</a>	HVAC - Automatic .....	<a href="#">5-17</a>
Fixed and Moveable Windows .....	<a href="#">2-3</a>	HVAC - Manual .....	<a href="#">5-28</a>
Horns and Pedestrian Alerts .....	<a href="#">2-12</a>	<b>Power and Signal Distribution</b> .....	<a href="#">6-1</a>
Lighting .....	<a href="#">2-15</a>	Data Communications .....	<a href="#">6-3</a>
Mirrors .....	<a href="#">2-44</a>	Electrical Component and Inline Harness	
Trailer Systems .....	<a href="#">2-57</a>	Connector End Views .....	<a href="#">6-30</a>
Vehicle Access .....	<a href="#">2-69</a>	Electrical Component Locator and Harness	
<b>Driver Information and Entertainment</b> .....	<a href="#">3-1</a>	Routing Views .....	<a href="#">6-914</a>
Image Display Cameras .....	<a href="#">3-3</a>	Power Outlets .....	<a href="#">6-961</a>
<b>Engine/Propulsion</b> .....	<a href="#">4-1</a>	Wiring Systems and Power	
Starting, Charging, and Low Voltage Energy		Management .....	<a href="#">6-976</a>
Storage .....	<a href="#">4-3</a>	<b>Transmission</b> .....	<a href="#">7-1</a>
		Shift Lock Control .....	<a href="#">7-3</a>
		<b>INDEX</b> .....	<a href="#">INDEX-1</a>

**BLANK**

## Section 1

# General Information

<b>General Information</b> .....	<a href="#">1-3</a>
<b>Introduction</b> .....	<a href="#">1-3</a>
Training .....	<a href="#">1-3</a>
Vehicle, Engine and Transmission ID and VIN Location, Derivative and Usage .....	<a href="#">1-4</a>
Vehicle Certification, Tire Placard, and Anti-Theft Label .....	<a href="#">1-6</a>
RPO Code List .....	<a href="#">1-8</a>

**BLANK**



# General Information

## Introduction Training

### Dealers

All U.S. GM Dealers participating in the Center of Learning / GM Service Technical College (STC) Programs can enroll through the Center of Learning website at <https://www.centerlearning.com>. Within the website, there are individual training paths that are designed to assist in planning the training needs for each individual and their job role. Dealers who have questions about Center of Learning Training should contact the Center of Learning help desk at 1-888-748-2687. The help desk is available Monday through Friday, 8:00 am – 9:00 pm Eastern Standard Time, excluding holidays. For GM Access support, contact the GM Access Help Desk at 1-888-337-1010.

### Fleets

GM Fleet customers with GM Warranty In-Shop agreements are able to participate in service technical training through the Center of Learning/GM Service Technical College (STC).

Assistance for GM fleet registered customers using GM STC training is provided by the Center of Learning help desk at 1-888-748-2687. The help desk is available Monday through Friday, 8:00 am–9:00 pm Eastern Standard Time, excluding holidays. For GM Access support, contact the GM Access Help Desk at 1-888-337-1010.

Most GM STC course materials have associated charges.

To purchase authentic GM STC Training Materials, contact the GM Training Materials Headquarters at 1-800-393-4831.

### Non-GM Dealer Technicians

Technician training for non-GM dealers is available through ACDelco. This training is for ACDelco PSC and Fleet program members employed in the automotive or truck service industry.

ACDelco courses are available at approved GM STC Training Centers. Availability and schedules can be obtained by calling 1-800-825-5886 (prompt 1) or contact us via the web at [www.acdelcotechconnect.com](http://www.acdelcotechconnect.com) and select the Training tab. Seminars are also offered through the ACDelco Warehouse Distribution channel. Contact your Local ACDelco representative or distributor directly for more information.

## 1-4 General Information

### Vehicle, Engine and Transmission ID and VIN Location, Derivative and Usage



5028742

The vehicle identification number (VIN) plate (1) is the legal identifier of the vehicle. The VIN plate is located on the upper left corner of the instrument panel. The VIN number can be seen through the windshield from the outside of the vehicle:

#### Vehicle Identification Number (VIN) System

Position	Definition	Character	Description
1	Country of Origin	1	United States
		2	Canada
		3	Mexico
2	Manufacturer	G	General Motors
3	Vehicle Brand/Type	B	Chevrolet Incomplete
		C	Chevrolet Truck
4	GVWR/Brake System/Body Style	N	6,001–7,000 lbs/Hydraulic/Standard Cab
		P	6,001–7,000 lbs/Hydraulic/Crew Cab
		R	6,001–7,000 lbs/Hydraulic/Extended Cab
		U	7,001–8,000 lbs/Hydraulic/Crew Cab
		V	7,001–8,000 lbs/Hydraulic/Extended Cab

**Vehicle Identification Number (VIN) System (cont'd)**

Position	Definition	Character	Description
5/6	Line Chassis/Series	A/A	4x2, 1500 Chevrolet Silverado, Work Truck
		A/B	4x2, 1500 Chevrolet Silverado, Custom
		A/C	4x2, 1500 Chevrolet Silverado, LT
		A/D	4x2, 1500 Chevrolet Silverado, RST
		A/E	4x2, 1500 Chevrolet Silverado, LTZ
		A/F	4x2, 1500 Chevrolet Silverado, High Country
		A/9	4x2, 1500 Chevrolet Silverado, (Non-US, Non-Canada)
		D/A	4x4, 1500 Chevrolet Silverado, Work Truck
		D/B	4x4, 1500 Chevrolet Silverado, Custom
		D/C	4x4, 1500 Chevrolet Silverado, Trail Boss Custom
		D/D	4x4, 1500 Chevrolet Silverado, LT
		D/E	4x4, 1500 Chevrolet Silverado, RST
		D/F	4x4, 1500 Chevrolet Silverado, Trail Boss - LT
		D/G	4x4, 1500 Chevrolet Silverado, LTZ
		D/H	4x4, 1500 Chevrolet Silverado ZR2
		D/J	4x4, 1500 Chevrolet Silverado High Country
		D/K	4x4, 1500 Chevrolet Silverado LTD LT-L
D/9	4x4, 1500 Chevrolet Silverado, (Non-US, Non-Canada)		
7	Restraint System	E	RPO AY0 – Active Manual Belts, Airbags – Driver and Passenger – Front (1st row), Front Seat Side (1st row), Roof Side (all seating rows)
8	Engine Type	D	RPO L84, Engine Gas, 8 Cylinder, 5.3L, DI, DFM*, Aluminum, GEN 5, VAR 2
		K	RPO L3B, Engine Gas, 4 Cylinder, L4, 2.7L, SIDI VVT, Turbo, DOHC, Aluminum
		L	RPO L87, Engine Gas, 8 Cylinder, V8, 6.2L, DI AFM, Aluminum, GEN 5
		8	LZ0 - ENGINE DIESEL, 6CYL, 3.0L, CRI, L6, DOHC, TURBO, VGT, ALUM, CSS50V, VAR 2
9	Check Digit	—	Check Digit
10	Model Year	R	2024
11	Plant Location	Z	Fort Wayne, Indiana, USA
		1	Oshawa, Canada
		G	Silao, Mexico
12–17	Plant Sequence Number	—	Plant Sequence Number

**2.7L (L3B) Engine ID and VIN Derivative Location**

Engine Identification

**3.0L (LZO) Diesel Engine ID and VIN Derivative Location**

Engine Identification

**5.3L (L84) or 6.2L (L87) Engine ID and VIN Derivative Location**

Engine Identification

**10L80 (MQB) Transmission ID and VIN Derivative Location**

Transmission Identification Information

**8L90 (MQE) Transmission ID and VIN Derivative Location**

Transmission Identification Information

## 1-6 General Information

### Vehicle Certification, Tire Placard, and Anti-Theft Label

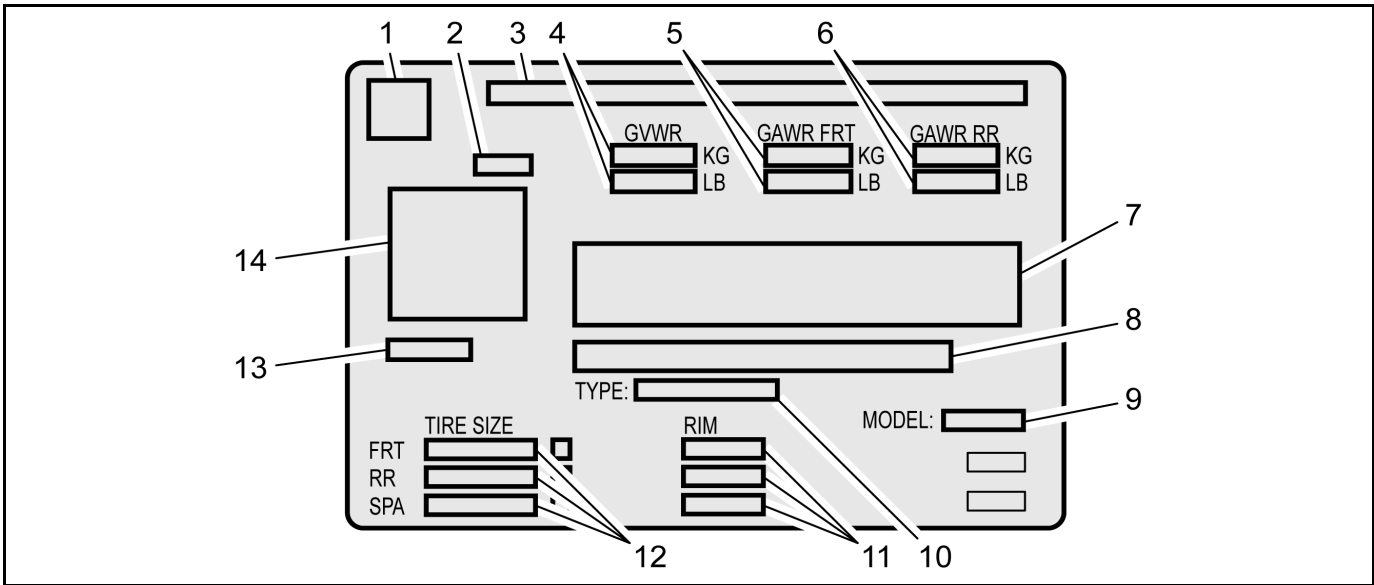

4992823

### Vehicle Certification Label

Callout	Description
A vehicle-specific Certification label is attached to the vehicle's center pillar (B-pillar) and displays the following assessments:	
1	Logo
2	Final Date of Manufacture (Month and Year MM/YY) Date of manufacture is to reflect the date that the vehicle is counted as built. In those cases where a replacement label is needed, the replacement label should reflect the actual build date not the date of replacement.
3	Name of Manufacturer
4	Maximum Gross Vehicle Weight Rating (GVWR)
5	Maximum Gross Axle Weight Rating (GAWR) - Front
6	Maximum Gross Axle Weight Rating (GAWR) - Rear
7	Certification Statement
8	Vehicle Identification Number (VIN)
9	Engineering Model Number
10	Vehicle Class Type (Pass Car, etc.)
11	Original Equipment Rim Size
12	Original Equipment Tire Size
13	Paint Code
14	QR Code Once the QR code is scanned, the information will appear in this order on your smartphone or laptop: VIN, Model Year, Model, Build Month, Year, Engineering Book, Vehicle Order Number, 3 Digit RPO Codes sorted alphanumerically and the Paint Code (same code appears the lower left of the QR code)

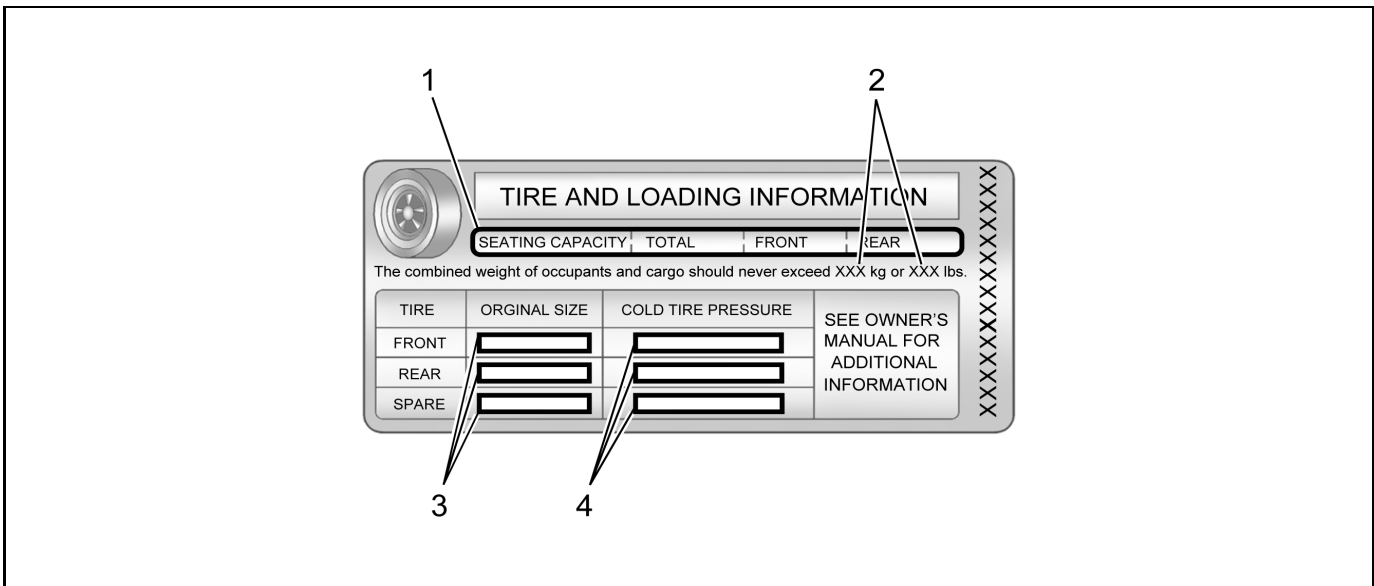

4962282

### Tire Placard

Callout	Description
A vehicle-specific Tire and Loading Information label is attached to the vehicle's center pillar (B-pillar) and displays the following assessments:	
1	Specified Occupant Seating Positions
2	Maximum Vehicle Capacity Weight
3	Original Equipment Tire Size
4	Tire Pressure, Front, Rear, and Spare (Cold)

## 1-8 General Information

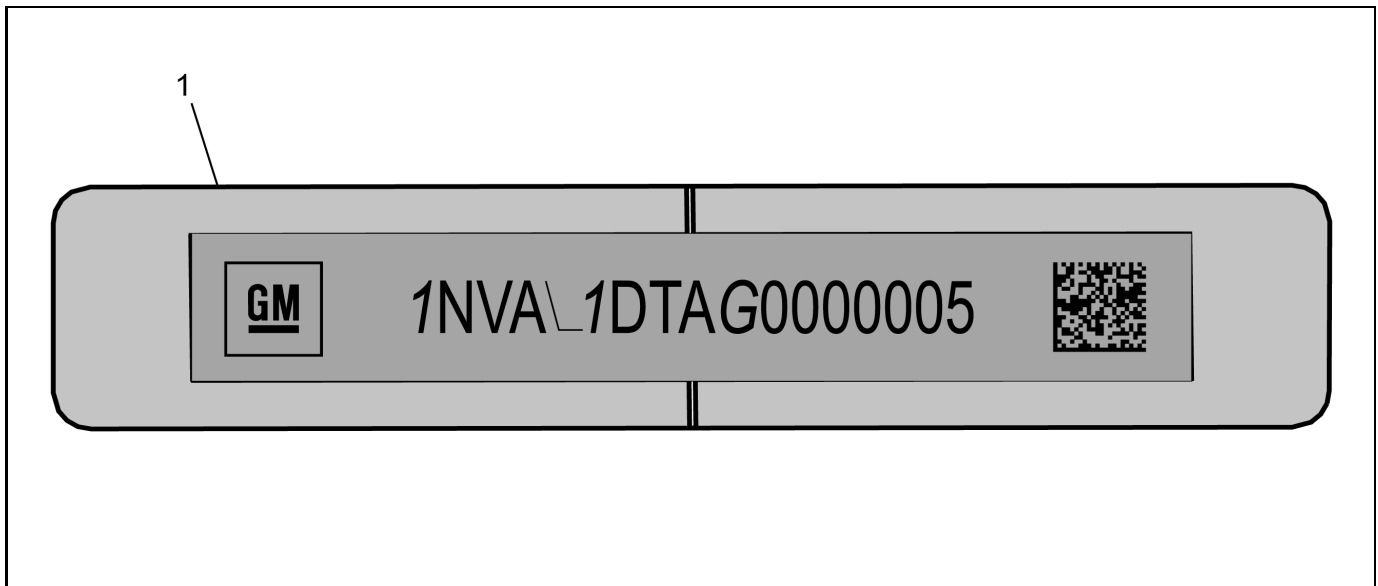

4962289

### Anti-Theft Label

Callout	Description
	This legal identifier is in the front corner of the instrument panel, on the driver side of the vehicle. It can be seen through the windshield from outside. The Vehicle Identification Number (VIN) also appears on the Vehicle Certification and certificates of title and registration.
1	Vehicle Identification Number (VIN)

### RPO Code List

The following table provides the description of the Regular Production Option (RPO) codes that are available on the vehicle. The vehicle's RPO list is printed on the Service Parts Identification Label.

RPO	Description
00C	IDENTIFICATION - NOT EQUIPPED WITH WIRELESS CHARGING MODULE
00H	IDENTIFICATION - EQUIPPED WITH HVAC MODULE WITH BRUSHED MOTOR
00J	IDENTIFICATION - EQUIPPED WITH SENSING DIAGNOSTIC MODULE DESIGN 2
00S	IDENTIFICATION - NOT EQUIPPED WITH SIDE BLIND ZONE ALERT
1CX	PACKAGE - CX OPTION 1
1LT	PACKAGE - LT OPTION 1
1LZ	PACKAGE - LZ OPTION 1
1SP	PACKAGE - OPTION 14
1WT	PACKAGE - WT OPTION 1
2CX	PACKAGE - CX OPTION 2
2FL	PACKAGE - FL OPTION 2
2LT	PACKAGE - LT OPTION 2
3LT	PACKAGE - LT OPTION 3
3LZ	PACKAGE - LZ OPTION 3
4AA	INTERIOR TRIM - JET BLACK
4AK	INTERIOR TRIM - JET BLACK/ CAPTAIN BLUE

RPO	Description
4JJ	INTERIOR TRIM - GIDEON/VY DK ATMOSPHERE
4JS	INTERIOR TRIM - JET BLACK/UMBER
4KW	INTERIOR TRIM - JET BLACK / ARTEMIS
5A7	WHEEL SPARE - NONE
5J9	CALIBRATION - TAILLAMP FLASHER, RED/WHITE (SEO)
5JL	ACCESSORY - BRAKE UPGRADE PKG 1 - COMPLETE
5JY	ACCESSORY - TONNEAU - RR COMPT - SOFT FOLDING
5LE	ACCESSORY - GARAGE DOOR OPENER
5LL	ACCESSORY - DECAL PACKAGE - BODYSIDE - DESIGN 10
5LM	ACCESSORY - DECAL PACKAGE - BODYSIDE - DESIGN 11
5LO	CALIBRATION - TAILLAMP FLASHER, RED/RED (SEO)
5VE	ACCESSORY - EXHAUST TIP - DESIGN 5
5VF	ACCESSORY - EXHAUST TIP - DESIGN 3
5VG	ACCESSORY - EXHAUST TIP - DESIGN 4
5VI	ACCESSORY - TIE DOWN RINGS - CARGO AREA
5W4	AIR CLEANER - HIGH CAPACITY
5W4	CALIBRATION - TAILLAMP FLASHER, RED/RED (SEO)
5W4	CALIBRATION - TAILLAMP FLASHER, RED/WHITE (SEO)

RPO	Description
5W4	FLASHER - HEADLAMP (SEO)
5W4	GENERATOR - 220 AMP
5W4	HITCH ASSIST - GUIDELINES
5W4	RECEPTACLE I/P - ELECTRICAL, 110 VOLT
5W4	TRAILER PROVISIONS - SPECIAL EQUIPMENT, H.D.
5W4	SALES PACKAGE - SPECIAL SERVICE, MUNICIPAL
5W7	ACCESSORY - AIR FILTER - PERFORMANCE
63G	ACCESSORY - TAILGATE ASSIST LIGHTING
65C	LABEL, WARNING - CALIFORNIA, PROP 65 COMPLIANT
6J7	FLASHER - HEADLAMP (SEO)
6K5	BRK APL CTRL FEATURE - INTEGRATED TRAILER BRAKE
6K5	IMAGE ADJUSTMENT - HITCH VIEW
6K5	INDICATOR - SMART TRAILER INTEGRATION
6K5	OPENER - GARAGE DOOR, UNIVERSAL
6K5	SPEAKER SYSTEM - PREMIUM AUDIO, BRANDED AMPLIFIER
6K5	WINDOW RR - FULL WIDTH, SLIDING, POWER
6K5	SALES PACKAGE - CONVENIENCE II
9C1	AIR CLEANER - HIGH CAPACITY
9C1	AXLE POSITRACTION - LIMITED SLIP
9C1	BRAKE SYSTEM - HEAVY DUTY
9C1	BRK APL CTRL FEATURE - HILL DESCENT, GEAR HOLD
9C1	CALIBRATION - SPEEDOMETER A
9C1	CALIBRATION - TAILLAMP FLASHER, RED/RED (SEO)
9C1	CALIBRATION - TAILLAMP FLASHER, RED/WHITE (SEO)
9C1	CRUISE CONTROL - AUTOMATIC, ELECTRONIC
9C1	ENGINE - GAS, 8 CYL, 5.3L, V8, DI, DFM, ALUM, GEN 5
9C1	FLASHER - HEADLAMP (SEO)
9C1	GENERATOR - 220 AMP
9C1	HITCH ASSIST - GUIDELINES
9C1	RECEPTACLE I/P - ELECTRICAL, 110 VOLT
9C1	RECEPTACLE PUBX - ELECTRICAL, 110 VOLT
9C1	SALES PACKAGE - SKID PLATE, "OFF ROAD" SPORT
9C1	TIRE ALL - 275/60R20 SL 115S BW AT
9C1	TIRE SPARE - 275/60R20 SL 115S BW AT

RPO	Description
9C1	TRAILER PROVISIONS - SPECIAL EQUIPMENT, H.D.
9C1	TRANSFER CASE - ACTIVE, TWO SPEED, SWITCH ACTIVATED, ALUM
9C1	WHEEL - 20 X 9.0, J, STEEL, DESIGN 1
9C1	WHEEL SPARE - 20 X 9.0, J, STEEL, DESIGN 1
9C1	SALES PACKAGE - POLICE VEHICLE
9J4	BUMPER RR - (NONE)
9L3	TIRE SPARE - NONE
9L7	EQUIPMENT - ACSRY WRG JUNC BLK
A2S	ADJUSTER DRIVER SEAT - 4WAY, DISCONT MAN RECLINE, MAN FORE/AFT
A2X	ADJUSTER DRIVER SEAT - 8WAY, PWR RECLINE, PWR FORE/AFT, PWR HEIGHT, PWR TILT
A45	MEMORY - SEAT ADJUSTER, MIRROR, POWER, DRIVER, PERSONALIZATION
A48	WINDOW RR - FULL WIDTH, SLIDING, POWER
A4H	HANDLING CHARGE - SHIP THROUGH TO GROUND EFFECT, OSHAWA, CANADA
A50	SEAT - FRT BKT
A60	LOCK CONTROL RR CMPT - LID, TAILGATE, KEY ACTIVATED
A68	SEAT RR - SPLIT, FOLDING
A7E	ADJUSTER PASS ST - 4WAY, DISCONT MAN RECLINE, MAN FORE/AFT
A7K	ADJUSTER PASS ST - 8WAY, PWR RECLINE, PWR FORE/AFT, PWR HEIGHT, PWR TILT
AAK	ACCESSORY - FLOOR LINER - CONTOURED - ALT DESIGN 1
AAO	ACCESSORY - FLOOR LINER - CONTOURED - ALT DESIGN 2
AED	WINDOW REG PASS DR - POWER OPERATED, EXPRESS DOWN
AEF	WINDOW REG PASS DR - POWER OPERATED, EXPRESS UP/DOWN
AEQ	WINDOW REG REAR DR - POWER OPERATED, EXPRESS DOWN
AKO	WINDOW TYPE - PRIVACY
AKP	WINDOW TYPE - SOLAR ABSORBING
AL0	SENSOR INDICATOR - INFLATABLE RESTRAINT, FRT PASS/CHILD PRESENCE DETECTOR
AMF	LOCK CONTROL - ADDITIONAL, PROGRAMMABLE, REMOTE ENTRY, MULTIPLE UNITS
AQQ	LOCK CONTROL, ENTRY - REMOTE ENTRY, EXTENDED RANGE (MY 09 AND FUTURE)
ASV	EQUIPMENT - SENSOR AIR MOISTURE & W/S TEMP
AU3	LOCK CONTROL - SIDE DR, ELEC
AU7	KEY - COMMON, FLEET



## 1-10 General Information

RPO	Description
AVI	RESTRAINT PROVISIONS - ADJUSTABLE GUIDE LOOP
AVJ	LOCK CONTROL, ENTRY - REMOTE ENTRY, EXTENDED RANGE, PASSIVE ENTRY, FRONT DOORS
AXG	WINDOW REG DRVR DR - POWER OPERATED, EXPRESS UP/DOWN
AXK	VEHICLE TYPE - TRUCK
AY0	RESTRAINT SYSTEM - SEAT, INFLATABLE, DRIVER & PASS FRT, SEAT SIDE, ROOF SIDE
AZ3	SEAT - FRT SPLIT, DRIVER, PASS, FULL FEATURE CENTER
B1J	LINER - RR WHEELHOUSE
B26	ALERT - SAFETY HAPTIC SEAT
B26	PARK ASSIST - FRONT AND REAR
B26	REAR CROSS TRAFFIC - ALERT, BRAKING
B26	SENSOR INDICATOR - PEDESTRIAN DETECTION - REAR
B26	SIDE ACTIVE SAFETY - OBSTACLE DETECTION ENHANCED
B26	SIDE ACTIVE SAFETY - OBSTACLE DETECTION ENHANCED, EXTENDED TRAILER VIEW
B26	VISION - 360 VIEW, MONO, HD DIGITAL
B26	VISION TRAILER - INSIDE VIEW, REAR VIEW
B26	SALES PACKAGE - SAFETY PACKAGE VAR. 1
B30	COVERING FLOOR - CARPET
B32	COVERING FRT - FLOOR MATS, AUX
B33	COVERING REAR - FLOOR MATS, AUX
B34	COVERING FRT - FLOOR MATS, CARPETED INSERT
B35	COVERING REAR - FLOOR MATS, CARPETED INSERT
B3L	STEPS, RUNNINGBOARD - SIDE, RETRACTABLE, POWER, BLACK
B59	DEFOGGER - RR WINDOW, ELECTRIC
B59	REMOTE START - VEHICLE
B59	THEFT DETERENT - ELECTRICAL, UNAUTHORIZED ENTRY
B59	SALES PACKAGE - FUNCTIONAL PACKAGE
BAQ	AIR CLEANER - HIGH CAPACITY
BAQ	SALES PACKAGE - SKID PLATE, "OFF ROAD" SPORT
BAQ	SALES PACKAGE - STYLE VAR 1
BCN	LOCK CONTROL - RETAIL LOCKING FEATURE (SEO)
BG9	COVERING FLOOR - RUBBER
BKE	COVERING REAR - FLOOR MATS, FLOOR LINER CARPET INSERT

RPO	Description
BKF	COVERING FRT - FLOOR MATS, FLOOR LINER CARPET INSERT
BN2	PARK ASSIST - FRONT AND REAR
BN2	REAR CROSS TRAFFIC - ALERT, BRAKING
BN2	SIDE ACTIVE SAFETY - OBSTACLE DETECTION ENHANCED
BN2	SALES PACKAGE - SAFETY PACKAGE VAR. 3
BPH	AIR CLEANER - HIGH CAPACITY
BPH	AXLE POSITRACTION - LIMITED SLIP
BPH	BRK APL CTRL FEATURE - HILL DESCENT, GEAR HOLD
BPH	CHASSIS PACKAGE - "OFF ROAD"
BPH	CHASSIS PACKAGE - "OFF ROAD" 2 INCH LIFT
BPH	EXHAUST SYSTEM - DUAL
BPH	EXHAUST SYSTEM - PERFORMANCE
BPH	SALES PACKAGE - SKID PLATE, "OFF ROAD" SPORT
BPH	TRANSFER CASE - ACTIVE, TWO SPEED, SWITCH ACTIVATED, ALUM
BPH	APPEARANCE PACKAGE - CHEVROLET "OFF ROAD"
BRS	STEPS, RUNNINGBOARD - SIDE, RETRACTABLE, POWER, BRIGHT
BTM	SWITCH - START, KEYLESS
BTV	REMOTE START - VEHICLE
BVT	STEPS, RUNNINGBOARD - SIDE, CHROME
BWN	STEPS - CORNER ASSIST, BUMPER
C32	HEATER AIR SYSTEM - HEATING/ DEFROSTER SYSTEM, REINFORCED, ELECTRIC
C49	DEFOGGER - RR WINDOW, ELECTRIC
C59	VENT - AIR, CONSOLE, RR
C67	HVAC SYSTEM - AIR CONDITIONER FRT, ELECTRONIC CONTROLS
CE1	WIPER SYS WINDSHIELD - PULSE, MOISTURE SENSITIVE
CF5	ROOF - SUN, GLASS, SLIDING, ELEC
CGN	LINER - PUBX, SPRAY ON
CJ2	HVAC SYSTEM - AIR CONDITIONER FRT, AUTO TEMP CONT, AUX TEMP CONT
CTT	HITCH ASSIST - GUIDELINES
CWK	ACCESSORY - EXHAUST TIP - DESIGN 2
CWK	EXHAUST SYSTEM - DUAL
CWK	EXHAUST SYSTEM - PERFORMANCE
CWK	HOOK - TOW
CWK	LINER - PUBX, SPRAY ON
CWK	WHEEL - 18 X 8.5, J, ALUMINUM, DESIGN 11



RPO	Description
CWK	WHEEL - 20 X 9.0, J, ALUMINUM, DESIGN 5
CWK	SALES PACKAGE - BLACK-OUT
CWM	CRUISE CONTROL - AUTOMATIC, ADAPTIVE, WITH STOP/GO
CWM	HEAD UP DISPLAY - WINDSHIELD
CWM	MIRROR I/S R/V - LT SENSITIVE, FULL VIDEO DISPLAY
CWM	STEERING COLUMN - TILT, TELESCOPING, POWER
CWM	VISION AUXILIARY - CARGO BED
CWM	SALES PACKAGE - TECHNOLOGY
CXH	INTERIOR TRIM CONFIG - LEATHER, LEVEL 1, GIDEON/VY DK ATMOSPHERE
CXH	INTERIOR TRIM CONFIG - LEATHER, LEVEL 1, JET BLACK
CXH	SEAT RR - SPLIT, FOLDING, DELUXE STORAGE
CXH	SALES PACKAGE - INTERIOR LEATHER PACKAGE
D07	CONSOLE - FRT COMPT, FLOOR, CUSTOM
D31	MIRROR I/S R/V - TILT
D72	HANDLE O/S DOOR - BLACK
D75	HANDLE O/S DOOR - BODY COLOR
DD8	MIRROR I/S R/V - LT SENSITIVE
DEN	MIRROR O/S - LH & RH, MANUAL, MANUAL FOLD, FLAT/DRVR, CNVX/PASS
DEZ	MIRROR O/S - LH & RH, ELEC REMOTE, POWER FOLD, HEAT, PERM LIGHT, LT SENSITIVE DRVR, FLAT/DRVR, CNVX/PASS
DH6	MIRROR I/S FRT VAN - LH & RH, SUNSHADE, ILLUM
DLF	MIRROR O/S - LH & RH, RC, ELEC, HEAT, MAN FOLD, FLAT/DRVR, CNVXPASS
DNS	EQUIPMENT - SUPPLIER INSTALLED
DP6	MIRROR PROVISIONS - HOUSING, PAINTED
DP9	MIRROR PROVISIONS - HOUSING, CHROME
DPO	MIRROR O/S - LH & RH, WIDE FIELD OF VIEW, MAN EXTEND, MAN FOLD, HEATED, REMOTE CONT, AUX CARGO LMP, AUX CLEAR LMP
DQS	MIRROR O/S - LH & RH, WIDE LOAD, VERT GLS,MAN EXT,PWR FLD,HTD,TURN SIG IND,R/CON,MEMORY,AUX CLEAR LP, AUX CARGO LP
DRZ	MIRROR I/S R/V - LT SENSITIVE, FULL VIDEO DISPLAY
E20	HANDLE O/S DOOR - CHROME
E35	PICKUP BOX INNER - STEEL
E63	BODY EQUIPMENT - FLEETSIDE PICK-UP BOX

RPO	Description
EF7	COUNTRY - UNITED STATES OF AMERICA (USA)
ENL	ENG CONTROL DISABLE - STOP/START, NON-LATCHING
EPH	TRANS RANGE SEL SYS - ELECTRONIC
EU2	ACCESSORY - WHEEL - 18" X 8.0 - J - ALUMINUM - DESIGN 2
F48	CHASSIS DRIVE LINE - ALL WHEEL DRIVE (AWD)/FOUR WHEEL DRIVE(4WD), DRIVER SELECT
FE9	CERTIFICATION - EMISSION, FEDERAL
FHS	VEHICLE FUEL - GASOLINE E85
FHX	VEHICLE FUEL - DIESEL B20
FJW	VEHICLE FUEL - GASOLINE E15
FWI	PLANT CODE - FT WAYNE, IN, USA
G0S	SALES PACKAGE - CAMO EDITION
G1W	PRIMARY COLOR - EXTERIOR, ABALONE WHITE TRICOAT(140X)
G6M	PRIMARY COLOR - EXTERIOR, RUSH MET-1 (618G)
G7C	PRIMARY COLOR - EXTERIOR, PULL ME OVER RED SOLID (130X)
G80	AXLE POSITRACTION - LIMITED SLIP
G93	AXLE - FRT ELECTRONIC LOCKING DIFFERENTIAL, DRIVER SELECT
G94	AXLE - RR ELECTRONIC LOCKING DIFFERENTIAL, DRIVER SELECT
GAZ	PRIMARY COLOR - EXTERIOR, SUMMIT WHITE (G) 8624
GBA	PRIMARY COLOR - EXTERIOR, BLACK (G) 8555
GEY	HANDLING CHARGE - FROM FT WAYNE ASM, TO GROUND EFFECTS LTD., FT WAYNE, IN, BACK TO FT WAYNE ASM.
GF2	TRIM PACKAGE - CUSTOM
GF3	TRIM PACKAGE - LT
GF4	TRIM PACKAGE - TRAIL BOSS LT
GF5	TRIM PACKAGE - WORK TRUCK
GF9	TRIM PACKAGE - LTZ
GFC	TRIM PACKAGE - RST
GFD	TRIM PACKAGE - HIGH COUNTRY
GG0	TRIM PACKAGE - LT-L
GLT	PRIMARY COLOR - EXTERIOR, POW ZINGA MET-1 (327E)
GNO	PRIMARY COLOR - EXTERIOR, BARB WIRE MET -1 (633D)
GNT	PRIMARY COLOR - EXTERIOR, RADIANT RED TINT MET-1 (170H)
GPZ	TRIM PACKAGE - TRAIL BOSS CUSTOM
GRZ	TRIM PACKAGE - ZR2
GT4	AXLE REAR - 3.73 RATIO
GU5	AXLE REAR - 3.23 RATIO
GU6	AXLE REAR - 3.42 RATIO

## 1-12 General Information

RPO	Description
GXD	PRIMARY COLOR - EXTERIOR, SHARKSKIN MET-1 (130H)
GXN	PRIMARY COLOR - EXTERIOR, RETROGRADE MET-1 (135H)
GXP	PRIMARY COLOR - EXTERIOR, COSMONAUT MET-1 (136H)
H0U	INTERIOR TRIM CONFIG - CLOTH, LEVEL 2, JET BLACK
H0Y	INTERIOR TRIM CONFIG - LEATHER, LEVEL 1, JET BLACK
H1T	INTERIOR TRIM CONFIG - CLOTH, LEVEL 1, JET BLACK
H1Y	INTERIOR TRIM CONFIG - LEATHER, LEVEL 2, JET BLACK
H2G	INTERIOR TRIM CONFIG - VINYL, LEVEL 1, JET BLACK
H37	INTERIOR TRIM CONFIG - LEATHER, LEVEL 7, JET BLACK / ARTEMIS
H38	INTERIOR TRIM CONFIG - LEATHER, LEVEL 8, JET BLACK / CAPTAIN BLUE
HF0	INTERIOR TRIM CONFIG - LEATHER, LEVEL 8, JET BLACK / UMBER
HS1	ALERT - SAFETY HAPTIC SEAT
HV5	INTERIOR TRIM CONFIG - CLOTH, LEVEL 2, GIDEON/VY DK ATMOSPHERE
HVC	INTERIOR TRIM CONFIG - LEATHER, LEVEL 1, GIDEON/VY DK ATMOSPHERE
HVE	INTERIOR TRIM CONFIG - LEATHER, LEVEL 2, GIDEON/VY DK ATMOSPHERE
HXC	INTERIOR TRIM CONFIG - LEATHER, LEVEL 8, JET BLACK
IOK	RADIO - INFOTAINMENT SYSTEM - 3.X MID/HIGH HMI, ENHANCED CONNECTIVITY 2.0, VOICE RECOGNITION
IOR	RADIO - INFOTAINMENT SYSTEM - 3.X LOW HMI, MIDLEVEL CONNECTIVITY 3.X
J24	ENGINEERING YEAR - 2024
J55	BRAKE SYSTEM - HEAVY DUTY
J61	BRAKE SYSTEM - POWER, FRT & RR DISC, ABS, 17"
JBP	BRAKE LINING WEAR SY - LIFE SPAN PROGNOSTIC INDICATOR
JHD	BRK APL CTRL FEATURE - HILL DESCENT, GEAR HOLD
JL1	BRK APL CTRL FEATURE - INTEGRATED TRAILER BRAKE
K05	HEATER ENG - BLOCK
K34	CRUISE CONTROL - AUTOMATIC, ELECTRONIC
K47	AIR CLEANER - HIGH CAPACITY
K4C	CHARGER - INDUCTIVE PORTABLE WIRELESS DEVICE
KA1	HEATER SEAT FRT - DRVR & PASS
KA6	HEATER SEAT - REAR
KC4	COOLING SYSTEM - ENG OIL

RPO	Description
KC5	RECEPTACLE - ELECTRICAL, ACCESSORY
KC9	RECEPTACLE PUBX - ELECTRICAL, 110 VOLT
KGU	MODULE - UPFITTER, SERIAL DATA GATEWAY
KI3	STEERING WHEEL HEAT - AUTOMATIC
KI4	RECEPTACLE I/P - ELECTRICAL, 110 VOLT
KL9	ENG CONTROL - STOP/START SYS, CONVENTIONAL AT, CONVENTIONAL MT OR BRAKE RELEASE LATE RESTART
KLF	ENG CONTROL - STOP/START SYS, DISABLE FUNCTION
KNP	COOLING SYSTEM - TRANS, HD
KQV	HEATER - SEAT, VENTED, FRT
KSG	CRUISE CONTROL - AUTOMATIC, ADAPTIVE, WITH STOP/GO
KW5	GENERATOR - 220 AMP
KW7	GENERATOR - 170 AMP
L3B	ENGINE - GAS, 4 CYL, L4, 2.7L, SIDI, VVT, TURBO, DOHC, ALUM
L84	ENGINE - GAS, 8 CYL, 5.3L, V8, DI, DFM, ALUM, GEN 5
L87	ENGINE - GAS, 8 CYL, V8, 6.2L, DI, DFM, ALUM, GEN 5
LZ0	ENGINE - DIESEL, 6 CYL, 3.0L, CRI, L6, DOHC, TURBO, VGT, ALUM, CSS50V, VAR. 2
MAH	MARKETING AREA - US, PUERTO RICO/USVI
MFC	TRANSMISSION - AUTO 8 SPD, 8L80, GEN 2, ATSS, CPA
MHS	TRANSMISSION - AUTO 10 SPD, 10L80, GRX, GEN 1, ATSS, ETRS, VAR 1
MHT	TRANSMISSION - AUTO 10 SPD, 10L80, GRX, GEN 1, ATSS, VAR 1
MI2	TRANSMISSION - AUTO 10 SPD, 10L80, GRX, VAR 1, GEN 1
MQB	TRANSMISSION - AUTO 10 SPD, 10L80, ATSS, CPA, GEN 2
MQC	TRANSMISSION - AUTO 10 SPD, 10L80, ATSS, ETRS, CPA, GEN 2
MSL	PLANT CODE - SILAO, MEXICO
N06	STEERING COLUMN LOCK - ELECTRICAL
N10	EXHAUST SYSTEM - DUAL
N33	STEERING COLUMN - TILT TYPE
N37	STEERING COLUMN - TILT, TELESCOPING
N38	STEERING COLUMN - TILT, TELESCOPING, POWER
N57	STEERING WHEEL - SYNTHETIC, 4 SPOKE, THIN, ROUND
N5G	STEERING WHEEL - SYNTHETIC, 4 SPOKE, SPORT, ROUND

RPO	Description
NAA	ACCESSORY - ROCKER GUARD - TUBULAR
NB5	EXHAUST SYSTEM - SINGLE
NE1	CERTIFICATION - EMISSION, GEOGRAPHICALLY RESTRICTED REGISTRATION
NHT	AXLE POSITRACTION - LIMITED SLIP
NHT	AXLE REAR - 3.42 RATIO
NHT	AXLE REAR - 3.73 RATIO
NHT	BRK APL CTRL FEATURE - INTEGRATED TRAILER BRAKE
NHT	PERFORMANCE PACKAGE - ENHANCED TOWING
NK5	STEERING WHEEL - STANDARD
NP0	TRANSFER CASE - ACTIVE, SINGLE SPEED, SWITCH ACTIVATED, ALUM
NPP	EXHAUST SYSTEM - PERFORMANCE
NQH	TRANSFER CASE - ACTIVE, TWO SPEED, SWITCH ACTIVATED, ALUM
NTB	EMISSION SYSTEM - FEDERAL, TIER 3
NUB	EMISSION SYSTEM - CALIFORNIA, ULEV70
NUC	EMISSION SYSTEM - CALIFORNIA, ULEV50
NUG	EMISSION SYSTEM - CALIFORNIA, SULEV30
NZN	WHEEL - 20 X 9.0, J, ALUMINUM, DESIGN 11
NZP	WHEEL - 20 X 9.0, J, ALUMINUM, DESIGN 12
NZV	WHEEL - 20 X 9.0, J, ALUMINUM, DESIGN 21
NZZ	SALES PACKAGE - SKID PLATE, "OFF ROAD" SPORT
OST	PLANT CODE - OSHAWA 2, ONT, CANADA
PPW	PHONE PROJECTION - PHONE PROJECTION WIRELESS
PTT	TRAILER TIRE PRESSUR - MANUAL LEARN
PXT	WHEEL - 20 X 9.0, J, STEEL, DESIGN 1
PZ8	IMAGE ADJUSTMENT - HITCH VIEW
PZ9	PLATE - SKID, FUEL TANK
PZG	PLATE - SKID FRT
PZL	PLATE - SKID RR DIFFERENTIAL
PZN	PLATE - SKID TRANSFER CASE
Q5U	WHEEL - 17 X 8.0, J, ALUMINUM, DESIGN 2
Q81	WHEEL - 18 X 8.5, J, ALUMINUM, DESIGN 17
QAB	TIRE ALL - 275/60R20 SL 115S BW AL2
QAE	TIRE ALL - 275/60R20 SL 115S BW AT
QAQ	TIRE SPARE - 255/80R17 SL 115S BW SPR

RPO	Description
QBN	TIRE ALL - 255/70R17 SL 112S BW ALS VAR 1
QBR	TIRE SPARE - 255/70R17 SL 112S BW ALS VAR1
QDF	TIRE ALL - 265/65R18 SL 114T BW ALS VAR 1
QDS	TIRE ALL - 265/65R18 SL 114T WOL AT VAR 1
QDV	TIRE ALL - 265/70R17 SL 115S BW AT VAR 1
QFL	TIRE ALL - LT275/70R18 C 115/112Q BW OOR, VAR1
QFV	TIRE ALL - LT265/60R20 C 110/107S BW OOR, VAR 1
QK1	GATE TYPE - PUBX END STANDARD
QK2	GATE TYPE - PUBX END ENHANCED
QT2	GATE FUNCTION - MANUAL
QT5	GATE FUNCTION - MANUAL ASSIST POWER RELEASE
QT6	GATE FUNCTION - POWER
R3O	TIRE ALL - LT275/65R18 C 113/110Q BW OOR, VAR1
R7O	SEAT RR - SPLIT, FOLDING, BASE STORAGE
R88	ACCESSORY - ILLUMINATED EMBLEM - EXTERIOR - DESIGN 2
RBR	WHEEL - 22 X 9.0, J, STEEL, DESIGN 1
RC5	TIRE ALL - LT265/70R17 C 112Q BW AT
RCP	ACCESSORY TIRE - TIRE ALL - LT275/65R18 C 113/110Q BW OOR VAR1
RCV	WHEEL - 18 X 8.5, J, ALUMINUM, DESIGN 4
RCW	WHEEL - 18 X 8.5, J, ALUMINUM, DESIGN 5
RD1	WHEEL - 18 X 8.5, J, ALUMINUM, DESIGN 6
RD5	WHEEL - 20 X 9.0, J, ALUMINUM, DESIGN 5
RD6	WHEEL - 17 X 8.0, J, STEEL, DESIGN 2
RDI	ACCESSORY - KEYLESS ENTRY
RHF	TIRE SPARE - LT275/70R18 C 115/112Q BW OOR
RHM	TIRE SPARE - LT265/70R17 C 112Q BW AT
RHO	WHEEL - 20 X 9.0, J, ALUMINUM, DESIGN 19
RIA	ACCESSORY - FLOOR LINER - CONTOURED
RIK	ACCESSORY - BADGE - EXTERIOR, PACKAGE, DESIGN 1
RM7	WHEEL SPARE - 17 X 8.0, J, STEEL, DESIGN 1
RMW	TIRE SPARE - 275/60R20 SL 115S BW AT
RN2	ACCESSORY - ILLUMINATED EMBLEM - EXTERIOR - DESIGN 1

## 1-14 General Information

RPO	Description
RNQ	WHEEL SPARE - 20 X 9.0, J, STEEL, DESIGN 1
RO1	ACCESSORY - GRILLES/GRILLE INSERT - ALTERNATE DESIGN 3
RPP	WHEEL - 17 X 8.0, J, STEEL, DESIGN 4
RPS	WHEEL - 20 X 9.0, J, ALUMINUM, DESIGN 13
RPT	WHEEL - 22 X 9.0, J, ALUMINUM, DESIGN 14
RQL	WHEEL - 18 X 8.5, J, ALUMINUM, DESIGN 11
RSR	OCCUPANT DETECT SYS - REAR SEAT, DOOR ACTIVATED
RVG	ACCESSORY - ADAPTER - TRAILER HARNESS
RVP	ACCESSORY - ASSIST STEPS - REMOVABLE
RVQ	ACCESSORY - ASSIST STEPS - TUBULAR - OVAL - BLACK
RVS	ACCESSORY - ASSIST STEPS - TUBULAR - ROUND - BLACK
RW9	ACCESSORY - BED STORAGE BOX - SIDE FULL LENGTH - COMPOSITE
RWA	ACCESSORY - BED STORAGE BOX - FOAM
RWL	CHASSIS DRIVE LINE - REAR WHEEL DRIVE (RWD)
RWS	ACCESSORY - FLOOR MATS - CARPET
RXC	ACCESSORY - AIR, POLLUTANT, ODOR, FINE DUST, ALLERGEN
RXH	ACCESSORY - CENTER CAP - WHEEL - DESIGN 1
RXJ	ACCESSORY - CENTER CAP - WHEEL - DESIGN 2
RXQ	ACCESSORY - CONVENIENCE NET - BED MOUNTED
RYT	ACCESSORY - FIRST AID KIT
S08	ACCESSORY - HIGHWAY SAFETY KIT
S0M	ACCESSORY - ILLUMINATED DOOR SILLS
S0T	ACCESSORY - INTERIOR TRIM KIT - ALTERNATE FINISH 1
S0Y	ACCESSORY - LAMPS - CARGO AREA
S1H	ACCESSORY - OFF-ROAD RECOVERY KIT
S1O	ACCESSORY - CONTAINER - LOCKABLE STORAGE - INTERIOR
S1W	WHEEL SPARE - 18 X 8.5, J, ALUMINUM, DESIGN 1
S2B	WHEEL SPARE - 17 X 7.0, J, ALUMINUM, DESIGN 1
S2E	WHEEL SPARE - 18 X 8.5, J, ALUMINUM, DESIGN 3
S3I	ACCESSORY - LAMPS - PERIMETER ILLUMINATION
S3U	ACCESSORY - LAMP KIT - FRONT FOG
S41	ACCESSORY - LINER - WHEEL HOUSE

RPO	Description
S47	ACCESSORY - LUG NUTS
S4C	WHEEL SPARE - 18 X 8.5, J, ALUMINUM, DESIGN 4
S4W	ACCESSORY - LUG NUT AND WHEEL LOCK KIT DESIGN 2
S4X	ACCESSORY - MIRROR COVERS/SKULL CAPS - ALTERNATE FINISH - PAINTED
S4Z	ACCESSORY - MIRRORS - TRAILER EXTENSION
S6L	ACCESSORY - PROTECTOR - ROCKER PANEL
S6N	ACCESSORY - RECEIVER COVER - TRAILER HITCH
S6P	ACCESSORY - REMOTE START KIT
S6Z	ACCESSORY - SEAT COVER - TAILORED - ALTERNATE MATERIAL
SAF	LOCK - SPARE TIRE, HOIST SHAFT
SAM	ACCESSORY - SKID PLATES
SB1	ACCESSORY - SPLASH GUARDS - FLAT
SB7	ACCESSORY - DECAL PACKAGE - DESIGN 1
SB9	ACCESSORY - DECAL PACKAGE - DESIGN 2
SBY	ACCESSORY - SPORT BAR - BED MOUNTED - DESIGN 1
SBZ	ACCESSORY - SPORT PEDAL KIT
SC1	ACCESSORY - STABILIZER BAR KIT
SD5	ACCESSORY - TIRE PRESSURE MONITOR
SDA	ACCESSORY - TOW HOOKS
SDE	ACCESSORY - TRAILER HITCH - REMOVABLE
SEM	ACCESSORY - WHEEL - 20" - ALUMINUM - DESIGN 5
SET	ACCESSORY - WHEEL - 22" - ALUMINUM - DESIGN 10
SEU	ACCESSORY - WHEEL - 22 X 9.0 - J - ALUMINUM - DESIGN 2
SEV	ACCESSORY - WHEEL - 22 X 9.0 - J - ALUMINUM - DESIGN 3
SEZ	ACCESSORY - WHEEL - 22 X 9.0 - J - ALUMINUM - DESIGN 6
SF5	ACCESSORY - WHEEL FLARES - ALTERNATE DESIGN - MOLDED COLOR
SF8	ACCESSORY - DECAL PACKAGE - DESIGN 3
SFE	ACCESSORY - WHEEL LOCKS
SFJ	ACCESSORY - WINDOW SHADES - REFLECTIVE
SFZ	ACCESSORY - EMBLEM - EXTERIOR - DESIGN 1
SG3	ACCESSORY - SPRINGS - SPORT SUSPENSION
SGM	ACCESSORY - WHEEL - 22 X 9.0 - J - ALUMINUM - DESIGN 9

RPO	Description
SIE	ACCESSORY - PUBX TIERED STORAGE
SIL	ACCESSORY - RSE - PORTABLE MEDIA CONNECTIVITY PKG - W/INTEGRATED POWER
SL7	ACCESSORY - PUBX LADDER / UTILITY RACK STANCHIONS
SMZ	ACCESSORY - OFF ROAD DRIVE SHAFT
SNR	SEAT RR - SPLIT, FOLDING, DELUXE STORAGE
SNS	ACCESSORY - DECAL PACKAGE - DESIGN 28
SPY	ACCESSORY - LUG NUTS - ALT FINISH
SPZ	ACCESSORY - WHEEL LOCKS - ALT FINISH
SRL	ACCESSORY - WHEEL - 22 X 9.0 - J - ALUMINUM - DESIGN 13
SRV	ACCESSORY - WHEEL - 22 X 9.0 - J - ALUMINUM - DESIGN 14
SSI	ACCESSORY - WHEEL - 22 X 9.0 - J - ALUMINUM - DESIGN 15
SSW	ACCESSORY - WHEEL - 22 X 9.0 - J - ALUMINUM - DESIGN 17
STH	SALES PACKAGE - RALLY 2
SUR	ACCESSORY - TRAILER TIRE PRESSURE MONITOR
T3U	LAMP FRT FOG - FRT FOG
T4Z	SEAT BELT SAFETY SYS - SHIFTER INTERLOCK, GEN 1, NON-CUSTOMIZABLE
T8Z	SEAT BELT SAFETY SYS - SHIFTER INTERLOCK, GEN 3, INFOTAINMENT CUSTOMIZABLE
TDM	MODE DRIVER SETTINGS - TEEN DRIVER, INFOTAINMENT
TQ5	HEADLAMP HIGH BEAM - AUTO CONTROL
TRG	VISION TRAILER - INSIDE VIEW, REAR VIEW
TRO	ACCESSORY - CAMERA PKG - TRAILERING AUX MOUNTED
TT0	ACCESSORY - TRAILERING HOOKUP ASSIST
TUF	ORNAMENTATION - EMBLEM, "TEXAS EDITION"
U12	LAMP - EXTR, OSRV MIRROR, TASK
U2J	DIGITAL AUDIO SYSTEM - S-BAND - NONE
U2K	DIGITAL AUDIO SYSTEM - S-BAND
U73	ANTENNA - FIXED, RADIO
U95	SPEAKER SYSTEM - 2, BASE
UBC	RECPT USB ARMREST - DUAL, CHARGE, DATA
UBI	RECPT USB FLR CNSL R - DUAL, CHARGE
UBJ	RECPT USB IP LWR - DUAL, CHARGE, DATA

RPO	Description
UD5	PARK ASSIST - FRONT AND REAR
UD7	PARK ASSIST - REAR
UDC	DISPLAY INSTRUMENT - DRIVER INFO ENHANCED (ONE COLOR GRAPHIC)
UDU	PROVISIONS - REAR CAMERA PREP
UDV	DISPLAY INSTRUMENT - DRIVER INFO ENHANCED, FULL CLUSTER (MULTI COLOR GRAPHIC)
UE1	COMMUNICATION SYSTEM - VEHICLE, ONSTAR
UE4	SENSOR INDICATOR - FOLLOWING DISTANCE
UET	INDICATOR - SMART TRAILER INTEGRATION
UEU	SENSOR INDICATOR - FORWARD COLLISION ALERT
UF2	LAMP - CARGO
UFB	REAR CROSS TRAFFIC - ALERT, BRAKING
UG1	OPENER - GARAGE DOOR, UNIVERSAL
UGA	HOOK - TOW, RED
UGN	COLL IMMINENT BRK - ALL SPEED, VEH FWD MOVEMENT, BRAKE PREFILL, INTEGRATED BRAKE ASSIST
UH5	INDICATOR - SEAT BELT WARNING, REAR SEAT
UHL	VEHICLE - U-HAUL
UHX	LANE ACTIVE SAFETY - KEEP ASSIST
UHY	COLL IMMINENT BRK - LOW SPEED, VEH FWD MOVEMENT, BRAKE PREFILL, INTEGRATED BRAKE ASSIST
UIR	INFOTAINMENT DISPLAY - NORMALLY BLACK COLOR (TFT), 7", WVGA 800X480P
UJN	TIRE PRESS INDICATOR - AUTO LEARN
UK3	CONTROL - STEERING WHEEL, ACCESSORY
UKC	SIDE ACTIVE SAFETY - OBSTACLE DETECTION ENHANCED
UKJ	PED DETECTION FRT - BASIC, PEDESTRIANS
UKK	SENSOR INDICATOR - PEDESTRIAN DETECTION - REAR
UKL	LANE ACTIVE SAFETY - KEEP ASSIST, HANDS FREE LANE FOLLOWING(ENTIRE SPEED RANGE)
UKV	SIDE ACTIVE SAFETY - OBSTACLE DETECTION ENHANCED, EXTENDED TRAILER VIEW
ULK	ACCESSORY - TOW HOOKS - RED
ULV	BUMPER FRT - SPORT
ULV	BUMPER RR - SPORT
ULV	GATE TYPE - PUBX END ENHANCED
ULV	PLATE - SKID FRT
ULV	PLATE - SKID RR DIFFERENTIAL
ULV	PLATE - SKID TRANSFER CASE



## 1-16 General Information

RPO	Description
ULV	PLATE - SKID, FUEL TANK
ULV	WHEEL - 18 X 8.5, J, ALUMINUM, DESIGN 17
ULV	WHEEL - 18 X 8.5, J, ALUMINUM, DESIGN 19
ULV	SALES PACKAGE - CHEVROLET BISON
UMN	SPEEDOMETER - INST, MILES & KILO, MILES ODOMETER
UQA	SPEAKER SYSTEM - PREMIUM AUDIO, BRANDED AMPLIFIER
UQF	SPEAKER SYSTEM - STANDARD AUDIO
URC	SWITCH - FLEXRIDE MODE SYSTEM
URD	INFOTAINMENT DISPLAY - NORMALLY BLACK COLOR (TFT) ,13.4", 2400X960
UTJ	THEFT DETERENT - ELECTRICAL, UNAUTHORIZED ENTRY
UV2	VISION - 360 VIEW, MONO, HD DIGITAL
UV6	HEAD UP DISPLAY - WINDSHIELD
UVB	VISION - REAR VIEW, MONO, HD DIGITAL
UVN	VISION AUXILIARY - CARGO BED
V46	BUMPER FRT - CHROME
V76	HOOK - TOW
V8D	VEHICLE STATEMENT - VEHICLE LABEL CONTENT - U.S. FMVSS
VAV	ACCESSORY - FLOOR MATS - ALL WEATHER
VB5	BUMPER FRT - COLOR
VBJ	ACCESSORY - UNDERSEAT STORAGE
VBN	ACCESSORY - PUBX CARPET
VBR	ACCESSORY - PUBX RUBBER MAT
VGC	PROTECTOR - FILM, PAINT ETCH PREVENTIVE
VH6	BUMPER FRT - BLACK
VHU	BUMPER FRT - SPORT
VJG	BUMPER RR - BLACK
VJH	BUMPER RR - CHROME
VK3	LICENSE PLATE FRONT - FRT MOUNTING PKG
VKU	ACCESSORY - MIRROR CAPS - CHROME
VLQ	HOOK - TOW, CHROME
VMK	ACCESSORY - CARGO MANAGEMENT SYSTEM RAILS
VNI	ACCESSORY - REAR FASCIA APPLIQUE - ALTERNATIVE FINISH 1
VOZ	ACCESSORY - TONNEAU - RR COMPT - HARD FOLDING - ALT DESIGN
VPB	ACCESSORY - TONNEAU - RR COMPT - VINYL W/ INTEGRAL CROSSBOW SUPPORTS
VPS	BUMPER RR - SPORT
VQE	PROTECTOR - FILM, EXTERIOR FRT PANEL, VAR 2

RPO	Description
VQK	ACCESSORY - SPLASH GUARDS - CUSTOM MOLDED
VQM	ACCESSORY - ASSIST STEPS - CHROME
VQO	ACCESSORY - ASSIST STEPS - BLACK
VQV	PROTECTOR - FILM, DOOR GUARDS, DOOR CUPS
VQY	ACCESSORY - TOW HOOKS - CHROME
VQZ	ACCESSORY - EXHAUST TIP - DESIGN 1
VST	ACCESSORY - SILL PLATES - ALTERNATE DESIGN 1
VSX	LABEL - TOWING
VT2	ACCESSORY - ASSIST STEPS - ALTERNATE FINISH
VT5	BUMPER RR - COLOR KEYED
VT7	OWNERS MANUAL - ENGLISH LANGUAGE
VTA	ACCESSORY - EXHAUST TIP - DESIGN 2
VTI	SHUTTERS - FRONT GRILLE, ACTIVE, UPR
VUK	ACCESSORY - TAILGATE LINER - PUBX
VV4	COMMUNICATION EQUIP - MOBILE INTERNET CONNECTIVITY
VW9	ACCESSORY - CENTER CAP - WHEEL - DESIGN 3
VWD	ACCESSORY - CENTER CAP - WHEEL - DESIGN 4
VXH	ACCESSORY - ASSIST STEPS - TUBULAR - CHROME - OVAL
VXJ	ACCESSORY - ASSIST STEPS - TUBULAR - CHROME - ROUND
VXT	VEHICLE TYPE - INCOMPLETE
VXW	ACCESSORY - ASSIST STEPS - MOLDED
VYN	ACCESSORY - WHEEL TRIM RING DESIGN 1
VYP	ACCESSORY - WHEEL TRIM RING DESIGN 2
VYU	PROVISIONS - SNOW PLOW PREP
VZ2	CALIBRATION - SPEEDOMETER A
VZX	ACCESSORY - PUBX BEDLINER
W09	ACCESSORY - TAILGATE GAP COVER
W1V	ACCESSORY - FLOOR MATS - PREMIUM CARPET - ALT DESIGN
W2D	ACCESSORY - CARGO NET
WBC	ACCESSORY - EXHAUST UPGRADE
WBP	BUMPER FRT - COLOR
WBP	BUMPER RR - COLOR KEYED
WBP	CHASSIS PACKAGE - "OFF ROAD" 2 INCH LIFT
WBP	COVERING FLOOR - CARPET
WBP	DIGITAL AUDIO SYSTEM - S-BAND
WBP	REMOTE START - VEHICLE
WBP	THEFT DETERENT - ELECTRICAL, UNAUTHORIZED ENTRY

RPO	Description
WBP	WHEEL - 18 X 8.5, J, ALUMINUM, DESIGN 3
WBP	WHEEL - 20 X 9.0, J, ALUMINUM, DESIGN 3
WGQ	ACCESSORY - ASSIST STEPS - TUBULAR - ROUND - BLACK
WGQ	EXHAUST SYSTEM - DUAL
WGQ	EXHAUST SYSTEM - PERFORMANCE
WGQ	WHEEL - 20 X 9.0, J, ALUMINUM, DESIGN 13
WGQ	SALES PACKAGE - REDLINE
WJP	BUMPER FRT - COLOR
WJP	BUMPER RR - COLOR KEYED
WJP	HANDLE O/S DOOR - BODY COLOR
WJP	HOOK - TOW
WJP	INTERIOR TRIM CONFIG - LEATHER, LEVEL 8, JET BLACK
WJP	MIRROR PROVISIONS - HOUSING, PAINTED
WJP	STEPS, RUNNINGBOARD - SIDE, RETRACTABLE, POWER, BLACK
WJP	TIRE ALL - 275/60R20 SL 115S BW AT
WJP	WHEEL - 20 X 9.0, J, ALUMINUM, DESIGN 5
WJP	SALES PACKAGE - MIDNIGHT EDITION
WLD	WINDOW CONTROL - REMOTE EXPRESS DOWN, ALL WINDOWS
WMI	SHUTTERS - FRONT GRILLE, ACTIVE, UPR AND LWR
WMY	VIN MODEL YEAR - 2024
WPC	CRUISE CONTROL - AUTOMATIC, ADAPTIVE, WITH STOP/GO
WPC	HEATER SEAT - REAR
WPC	OPENER - GARAGE DOOR, UNIVERSAL
WPC	WINDOW RR - FULL WIDTH, SLIDING, POWER
WPC	SALES PACKAGE - COMFORT AND CONVENIENCE
WPQ	LINER - PUBX, SPRAY ON
WPQ	LINER - RR WHEELHOUSE
WPQ	SALES PACKAGE - PROTECTION
X31	AIR CLEANER - HIGH CAPACITY
X31	AXLE POSITRACTION - LIMITED SLIP
X31	BRK APL CTRL FEATURE - HILL DESCENT, GEAR HOLD
X31	CHASSIS PACKAGE - "OFF ROAD"
X31	EXHAUST SYSTEM - DUAL
X31	EXHAUST SYSTEM - PERFORMANCE
X31	SALES PACKAGE - SKID PLATE, "OFF ROAD" SPORT
X31	TRANSFER CASE - ACTIVE, TWO SPEED, SWITCH ACTIVATED, ALUM

RPO	Description
X88	MARKET BRAND - CHEVROLET
XCE	TIRE ALL - 275/50R22 SL 111T BW AL2 VAR 1
XCK	TIRE ALL - 265/65R18 SL 114T BW AT VAR1
XCQ	TIRE SPARE - 265/70R17 SL 115S BW SPR VAR1
XD5	ACCESSORY TIRE - TIRE ALL-275/50R22 SL 111T BW AL2
XDF	ACCESSORY TIRE - TIRE ALL - 275/60R20 SL 115S BW AT
YD9	LEAF SPRING - COMPOSITE MONO LEAF
YF5	CERTIFICATION - EMISSION, CALIFORNIA
Z45	CHASSIS PACKAGE - CONTINUOUS DAMPING CONTROL
Z60	CHASSIS PACKAGE - HIGH PERFORMANCE
Z71	CHASSIS PACKAGE - "OFF ROAD"
Z7X	CHASSIS PACKAGE - "OFF ROAD" 2 INCH LIFT
Z82	TRAILER PROVISIONS - SPECIAL EQUIPMENT, H.D.
Z85	CHASSIS PACKAGE - INCREASED CAPACITY
ZL3	ADJUSTER DRIVER SEAT - 8WAY, PWR RECLINE, PWR FORE/AFT, PWR HEIGHT, PWR TILT
ZL3	CHARGER - INDUCTIVE PORTABLE WIRELESS DEVICE
ZL3	CONSOLE - FRT COMPT, FLOOR, CUSTOM
ZL3	CRUISE CONTROL - AUTOMATIC, ADAPTIVE, WITH STOP/GO
ZL3	CRUISE CONTROL - AUTOMATIC, ELECTRONIC
ZL3	DEFOGGER - RR WINDOW, ELECTRIC
ZL3	HEATER - SEAT, VENTED, FRT
ZL3	HVAC SYSTEM - AIR CONDITIONER FRT, AUTO TEMP CONT, AUX TEMP CONT
ZL3	LAMP - CARGO
ZL3	MIRROR O/S - LH & RH, RC, ELEC, HEAT, MAN FOLD, FLAT/DRVR, CNVXPASS
ZL3	MIRROR O/S - LH & RH, WIDE FIELD OF VIEW, MAN EXTEND, MAN FOLD, HEATED, REMOTE CONT, AUX CARGO LMP, AUX CLEAR LMP
ZL3	RECEPTACLE I/P - ELECTRICAL, 110 VOLT
ZL3	RECEPTACLE PUBX - ELECTRICAL, 110 VOLT
ZL3	RECPT USB FLR CNSL R - DUAL, CHARGE
ZL3	SEAT - FRT BKT
ZL3	SPEAKER SYSTEM - PREMIUM AUDIO, BRANDED AMPLIFIER

## 1-18 General Information

---

RPO	Description
ZL3	STEERING COLUMN - TILT, TELESCOPING
ZL3	STEERING COLUMN - TILT, TELESCOPING, POWER
ZL3	WINDOW TYPE - PRIVACY
ZL3	SALES PACKAGE - CONVENIENCE
ZL6	BRK APL CTRL FEATURE - INTEGRATED TRAILER BRAKE
ZL6	IMAGE ADJUSTMENT - HITCH VIEW
ZL6	INDICATOR - SMART TRAILER INTEGRATION
ZLQ	CRUISE CONTROL - AUTOMATIC, ADAPTIVE, WITH STOP/GO
ZLQ	CRUISE CONTROL - AUTOMATIC, ELECTRONIC
ZLQ	MIRROR O/S - LH & RH, RC, ELEC, HEAT, MAN FOLD, FLAT/DRVR, CNVXPASS
ZLQ	MIRROR O/S - LH & RH, WIDE FIELD OF VIEW, MAN EXTEND, MAN FOLD, HEATED, REMOTE CONT, AUX CARGO LMP, AUX CLEAR LMP
ZLQ	SALES PACKAGE - LS FLEET
ZM9	HEATER SEAT FRT - DRVR & PASS
ZM9	STEERING WHEEL HEAT - AUTOMATIC
ZM9	SALES PACKAGE - COMFORT & CONVENIENCE
ZRX	CHASSIS PACKAGE - HIGH PERFORMANCE LIFTED
ZW9	BODY EQUIPMENT - BASE BODY OR CHASSIS



## Section 2

# Body Systems

<p><b>Fixed and Moveable Windows</b> ..... <a href="#">2-3</a></p> <p>  <b>Schematic and Routing Diagrams</b> ..... <a href="#">2-3</a></p> <p>    Moveable Window Schematics ..... <a href="#">2-4</a></p> <p>    Defogger Schematics ..... <a href="#">2-10</a></p> <p>  <b>Description and Operation</b> ..... <a href="#">2-11</a></p> <p>    Power Windows Description and Operation .... <a href="#">2-11</a></p> <p>    Rear Window Defogger Description and     Operation ..... <a href="#">2-11</a></p> <p><b>Horns and Pedestrian Alerts</b> ..... <a href="#">2-12</a></p> <p>  <b>Schematic and Routing Diagrams</b> ..... <a href="#">2-12</a></p> <p>    Horn Schematics ..... <a href="#">2-13</a></p> <p>  <b>Description and Operation</b> ..... <a href="#">2-14</a></p> <p>    Horns System Description and Operation ..... <a href="#">2-14</a></p> <p><b>Lighting</b> ..... <a href="#">2-15</a></p> <p>  <b>Schematic and Routing Diagrams</b> ..... <a href="#">2-15</a></p> <p>    Headlights/Daytime Running Lights (DRL)     Schematics ..... <a href="#">2-16</a></p> <p>    Fog Lights Schematics ..... <a href="#">2-20</a></p> <p>    Exterior Lights Schematics ..... <a href="#">2-21</a></p> <p>    Interior Lights Schematics ..... <a href="#">2-34</a></p> <p>    Interior Lights Dimming Schematics ..... <a href="#">2-36</a></p> <p>  <b>Description and Operation</b> ..... <a href="#">2-40</a></p> <p>    Exterior Lighting Systems Description and     Operation ..... <a href="#">2-40</a></p> <p>    Interior Lighting Systems Description and     Operation ..... <a href="#">2-43</a></p> <p><b>Mirrors</b> ..... <a href="#">2-44</a></p> <p>  <b>Schematic and Routing Diagrams</b> ..... <a href="#">2-44</a></p> <p>    Inside Rearview Mirror Schematics ..... <a href="#">2-45</a></p> <p>    Outside Rearview Mirror Schematics ..... <a href="#">2-46</a></p> <p>  <b>Repair Instructions</b> ..... <a href="#">2-49</a></p> <p>    Inside Rearview Mirror Replacement ..... <a href="#">2-49</a></p> <p>  <b>Description and Operation</b> ..... <a href="#">2-54</a></p> <p>    Automatic Day-Night Mirror Description and     Operation ..... <a href="#">2-54</a></p> <p>    Outside Mirror Description and Operation ..... <a href="#">2-55</a></p> <p><b>Trailer Systems</b> ..... <a href="#">2-57</a></p> <p>  <b>Schematic and Routing Diagrams</b> ..... <a href="#">2-57</a></p> <p>    Trailer Systems Schematics ..... <a href="#">2-58</a></p> <p>  <b>Description and Operation</b> ..... <a href="#">2-63</a></p> <p>    Trailer Description and Operation ..... <a href="#">2-63</a></p> <p><b>Vehicle Access</b> ..... <a href="#">2-69</a></p> <p>  <b>Schematic and Routing Diagrams</b> ..... <a href="#">2-69</a></p>	<p>    Door Lock/Indicator Schematics ..... <a href="#">2-70</a></p> <p>    Release Systems Schematics ..... <a href="#">2-76</a></p> <p>    Endgate Schematics ..... <a href="#">2-77</a></p> <p>    Hood Latch Schematics ..... <a href="#">2-81</a></p> <p>  <b>Description and Operation</b> ..... <a href="#">2-82</a></p> <p>    Door Ajar Indicator Description and     Operation ..... <a href="#">2-82</a></p> <p>    Endgate Description and Operation (QT6) ..... <a href="#">2-82</a></p> <p>    Endgate Description and Operation (QT5     Without MultiPro Tailgate) ..... <a href="#">2-83</a></p> <p>    Endgate Description and Operation (QT5 With     MultiPro Tailgate) ..... <a href="#">2-84</a></p> <p>    Hood Ajar Indicator Description and     Operation ..... <a href="#">2-84</a></p> <p>    Power Door Locks Description and     Operation ..... <a href="#">2-84</a></p>
--	---

**BLANK**

# Fixed and Moveable Windows

## Schematic and Routing Diagrams

Moveable Window Schematics (Driver Window (AXG))

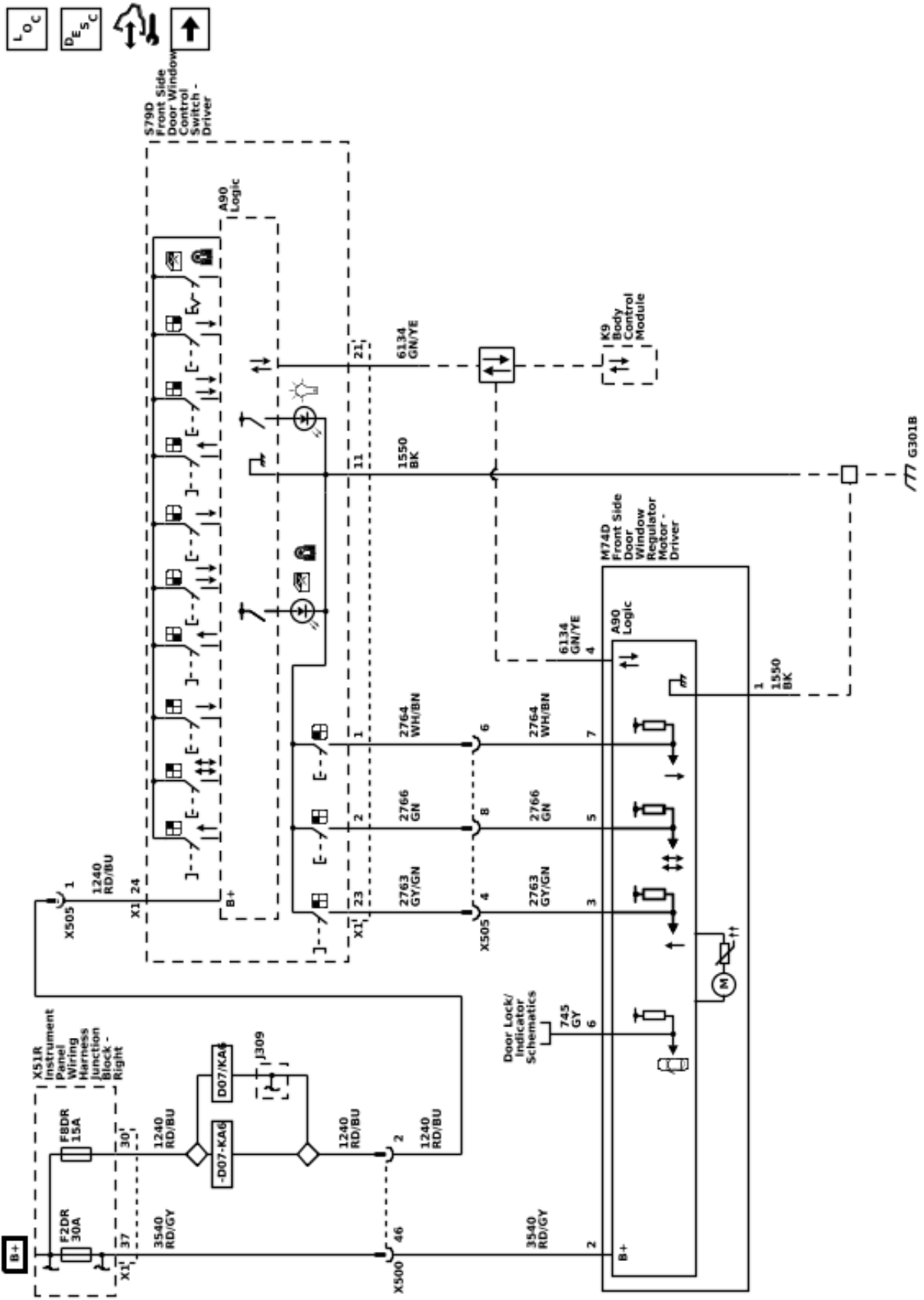

Moveable Window Schematics (Passenger Window (AEF))

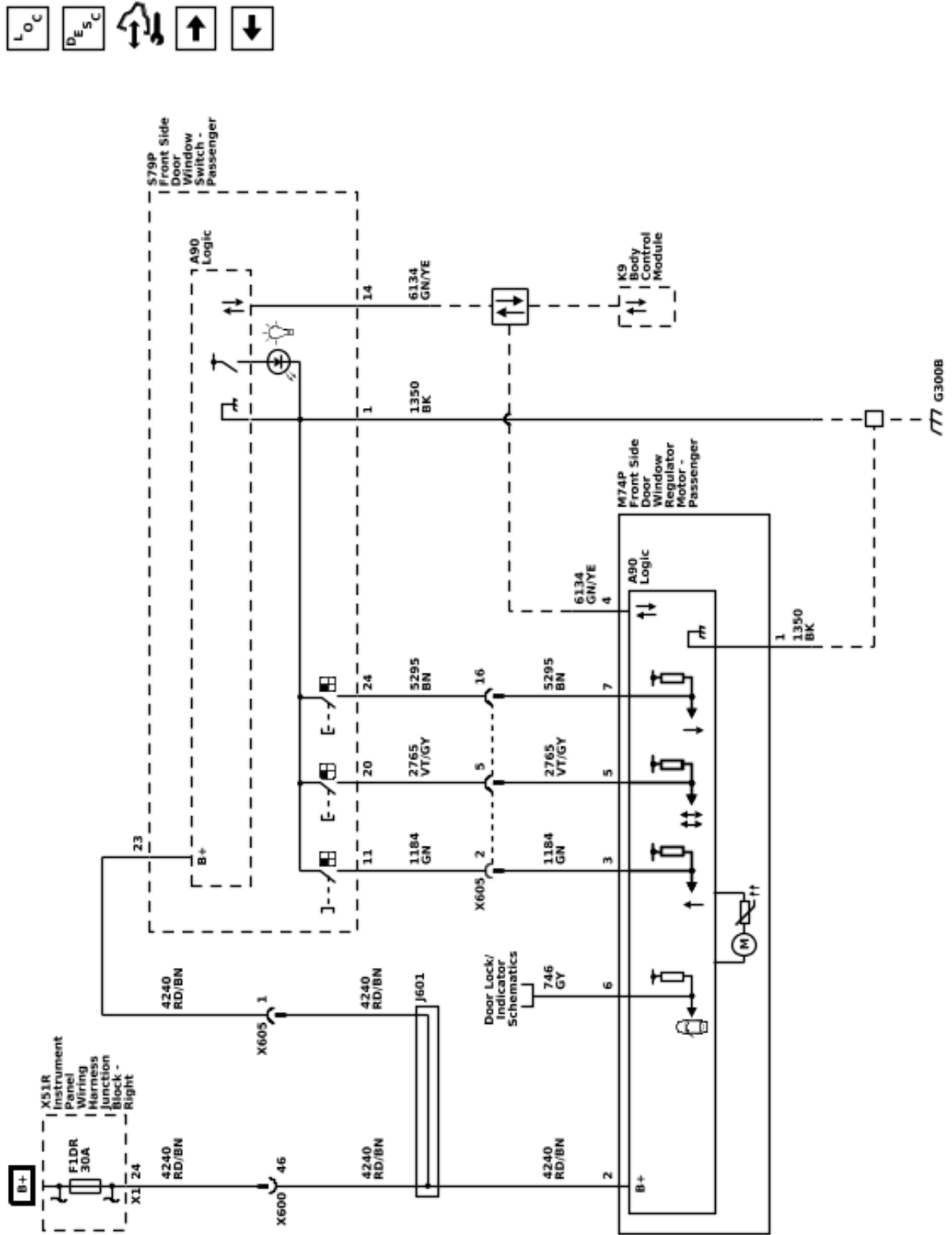

Moveable Window Schematics (Passenger Window (AED))

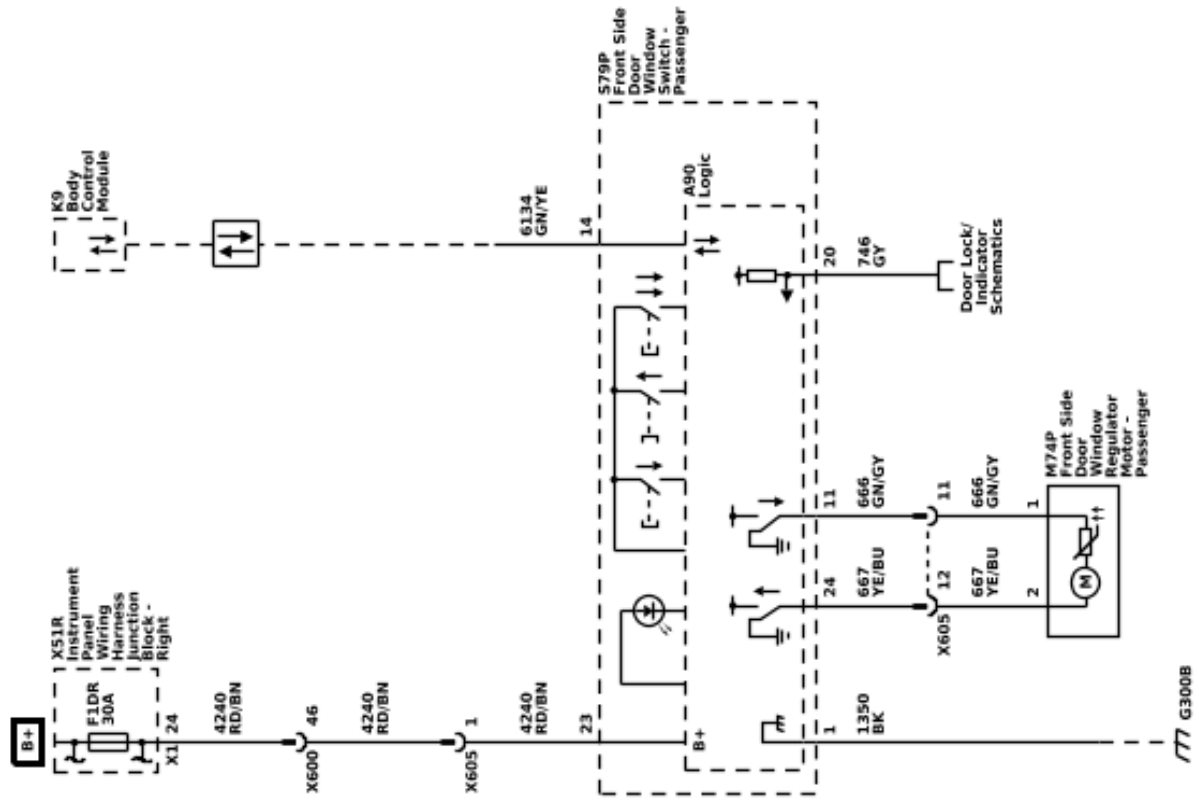

Moveable Window Schematics (Rear Windows (AEQ))

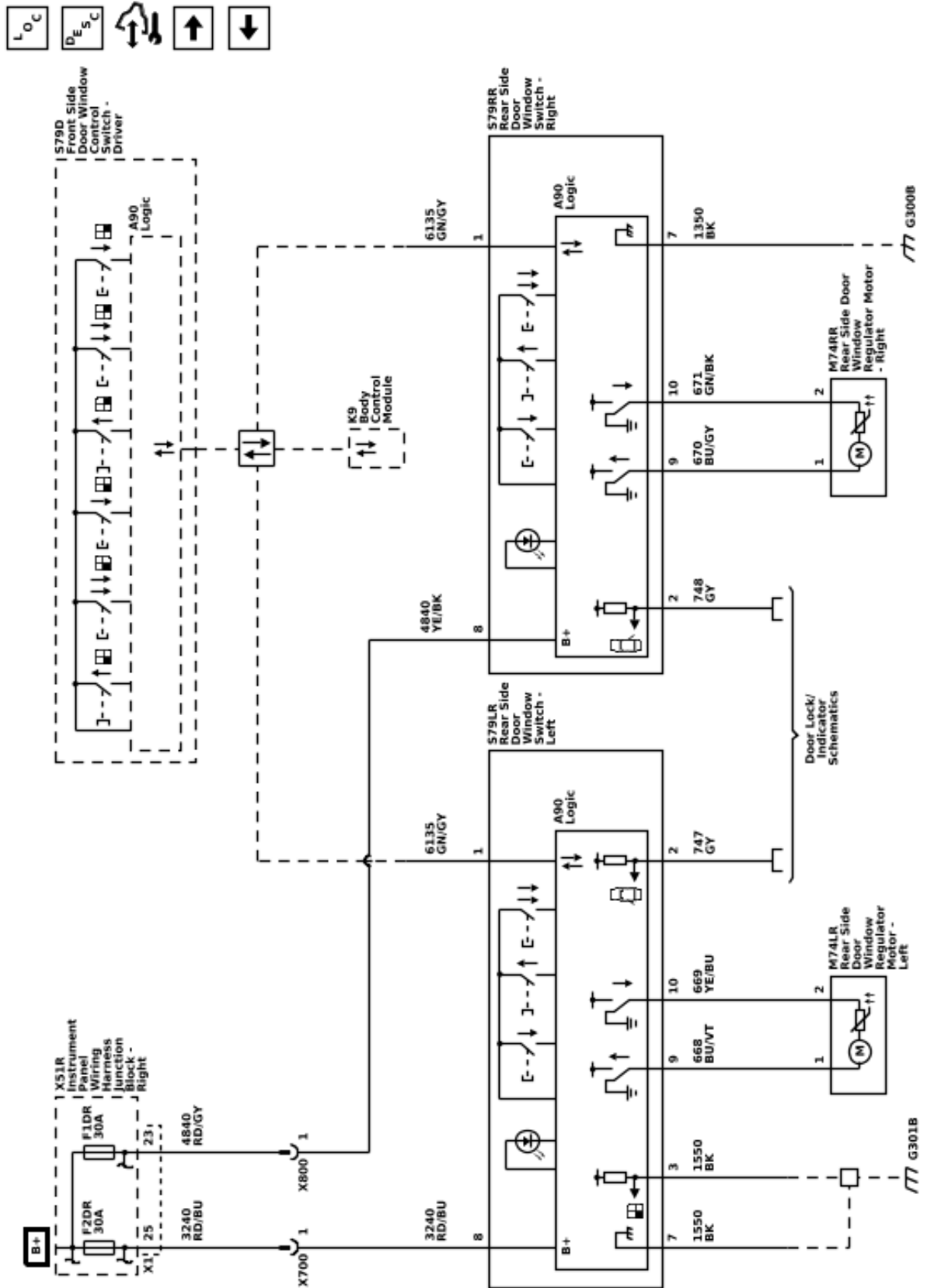

Moveable Window Schematics (Global Window Express Down Switch (WLD))

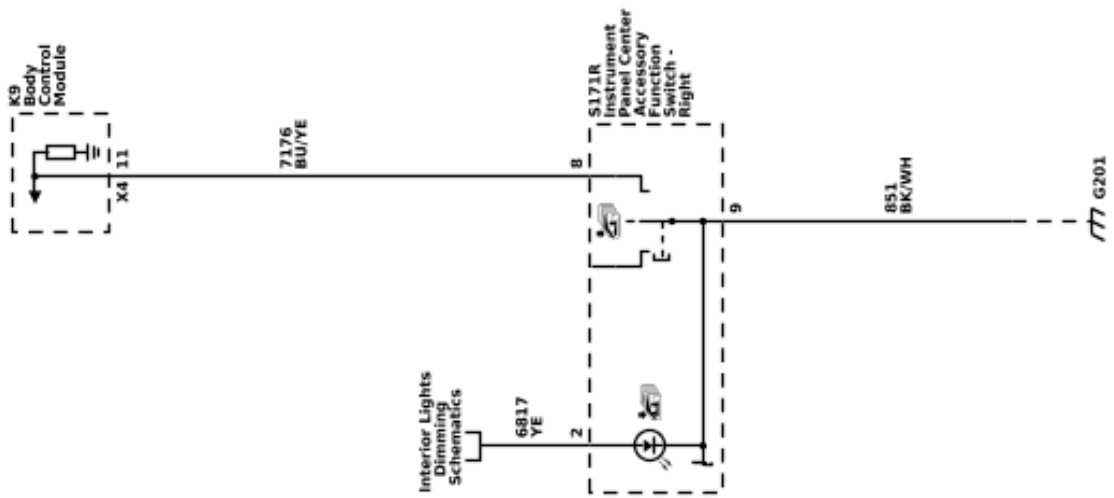



Moveable Window Schematics (Rear Sliding Window (A48))

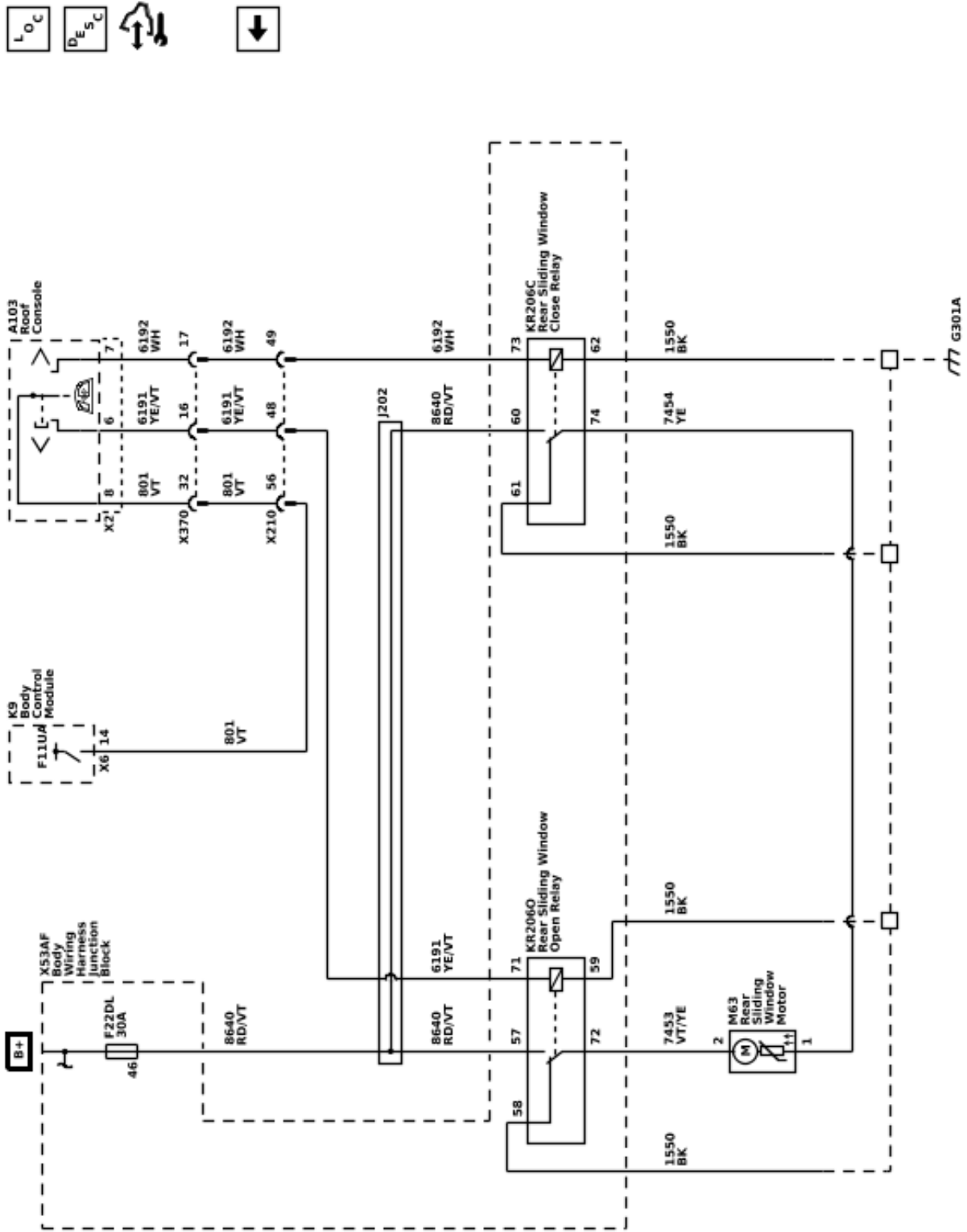

Defogger Schematics (Defogger)

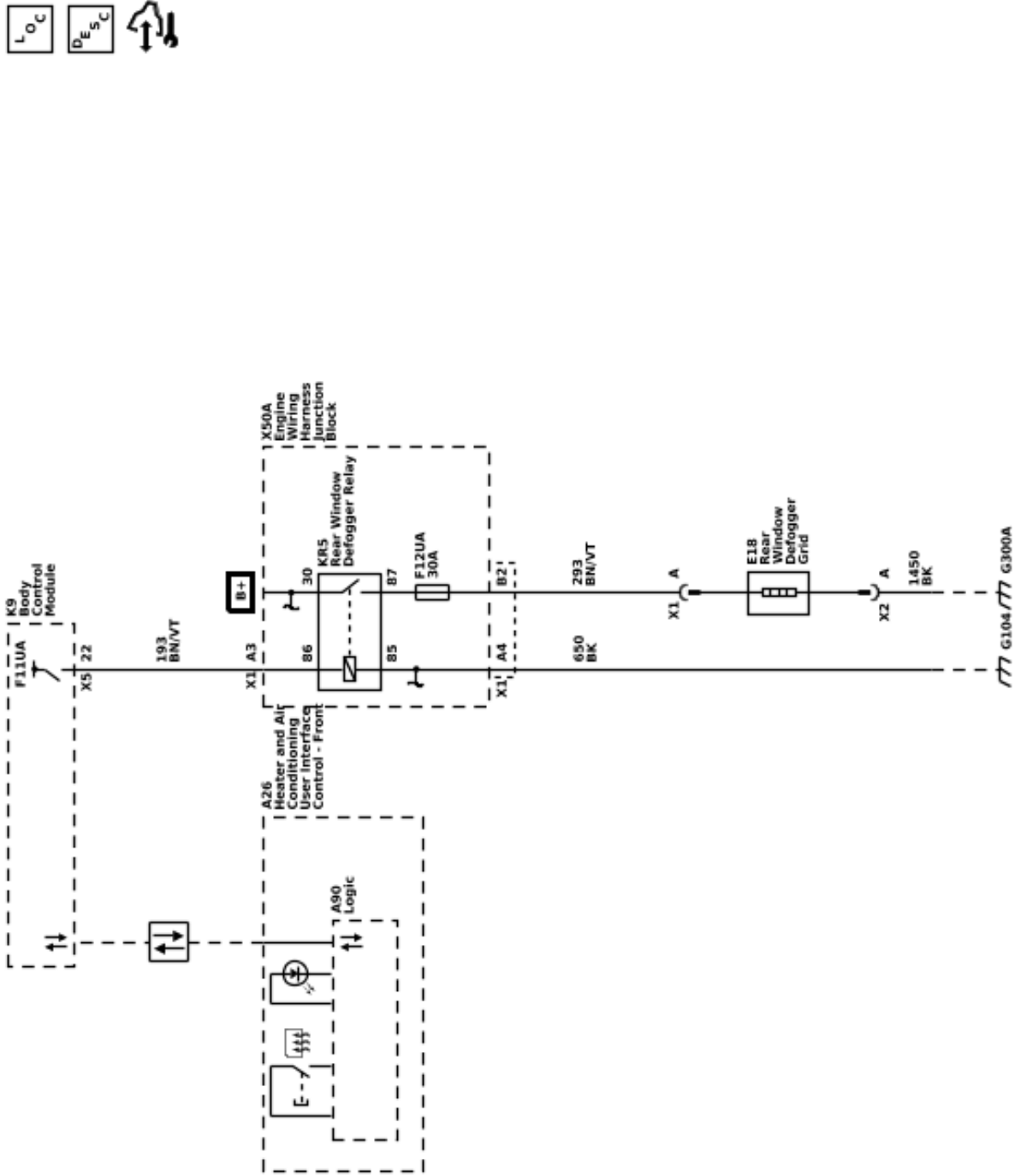

## Description and Operation

### Power Windows Description and Operation

#### Power Windows System Components

The power window system consists of the following components:

- Driver front side door window control switch
- Passenger front side door window control switch
- Left rear side door window switch
- Right rear side door window switch
- Window motors in each of the doors
- Body control module (BCM)

#### Driver and Passenger Express Up and Express Down Power Window Motors

The driver and passenger doors contains a window motor is smart motor that will detect excessive resistance while performing the express up function and automatically reverse direction to prevent injury to any occupants that may become trapped between the closing window and the door frame. The automatic reverse safety feature can be overridden by pulling and holding the window switch.

The logic circuit within the window motor monitors the up, down and express signal circuits which are normally equal to B+ voltage. When a switch is used on the front side door window control switch, the contacts close causing a voltage drop within the appropriate signal circuit. The window motor will detect the voltage drop and will command the window to move in the direction requested.

The driver front side door window control switch communicates to the BCM by a serial data circuit. When the driver wishes to control the passenger window, the driver will use the appropriate switch on the driver front side door window control switch. When this switch is used, a serial data message is sent to the BCM requesting the passenger window motor command, the BCM will then send a serial data message to the passenger window motor which will then move in the direction requested.

#### Left Rear, Right Rear Express Down Window Motors

For the right rear and left rear doors, when their window switch is pressed in the down position, battery positive voltage is applied to their respective window motor control circuit and ground to the other window motor control circuit causing that window to open. When the individual window switch is pulled in the up position, voltage and ground is applied to the window motor in the opposite direction causing that window to close. The return path to ground is supplied through the inactive control circuit being normally grounded through the window switch.

Each rear side door window switch communicates to the BCM by a serial data circuit. When the driver wishes to control the left rear or right rear window, the driver will use the appropriate switch on the driver front side door window control switch. When this switch is used, a serial data message is sent to the BCM

requesting a window motor command, the BCM will then send a serial data message to the appropriate rear side door window switch which will then command that window to move in the direction requested.

#### Lockout Switch Feature

The driver front side door window control switch contains a window lockout switch, when the driver presses the window lockout switch, a serial data message is sent to the BCM which will send a disable command to the rear side door window switches, deactivating them. The rear windows will still function normally from the switches on the driver front side door window control switch.

#### Rear Window Defogger Description and Operation

##### Rear Window Defogger System Components

The rear window defogger system consists of the following components:

- Body Control Module
- Front Heater and Air Conditioning User Interface Control
- Rear Body Wiring Harness Junction Block (Contains PCB Rear Defogger Relay)
- Rear Defogger Grid
- 40A Fuse

##### Rear Window Defogger Operation

The rear defog control system utilizes a single zone backlight design, driven with a single relay configuration. A switch for the customer to control the system is provided within the front heater and air conditioning user interface control. Also included in the front heater and air conditioning user interface control is an indicator to inform the customer with the current state of the system. The system is only operational when engine is running or during remote start.

Pressing the heated rear window switch causes the front heater and air conditioning user interface control to send a serial data message to the body control module requesting rear window defog operation. The body control module upon receipt of the serial data message will provide voltage to the coil side of the rear defogger relay, this will energize the relay causing the relay switch contacts to close allowing B+ voltage to flow through the rear defogger grid control circuit to the rear defogger grid.

When the rear heated rear window switch is pressed and the engine is running, the rear window defogger grid will activate and will turn off automatically depending upon the vehicle speed (refer to owner's manual for rear window defogger operation cycles)

## Horns and Pedestrian Alerts

### Schematic and Routing Diagrams

Horn Schematics (Horn)

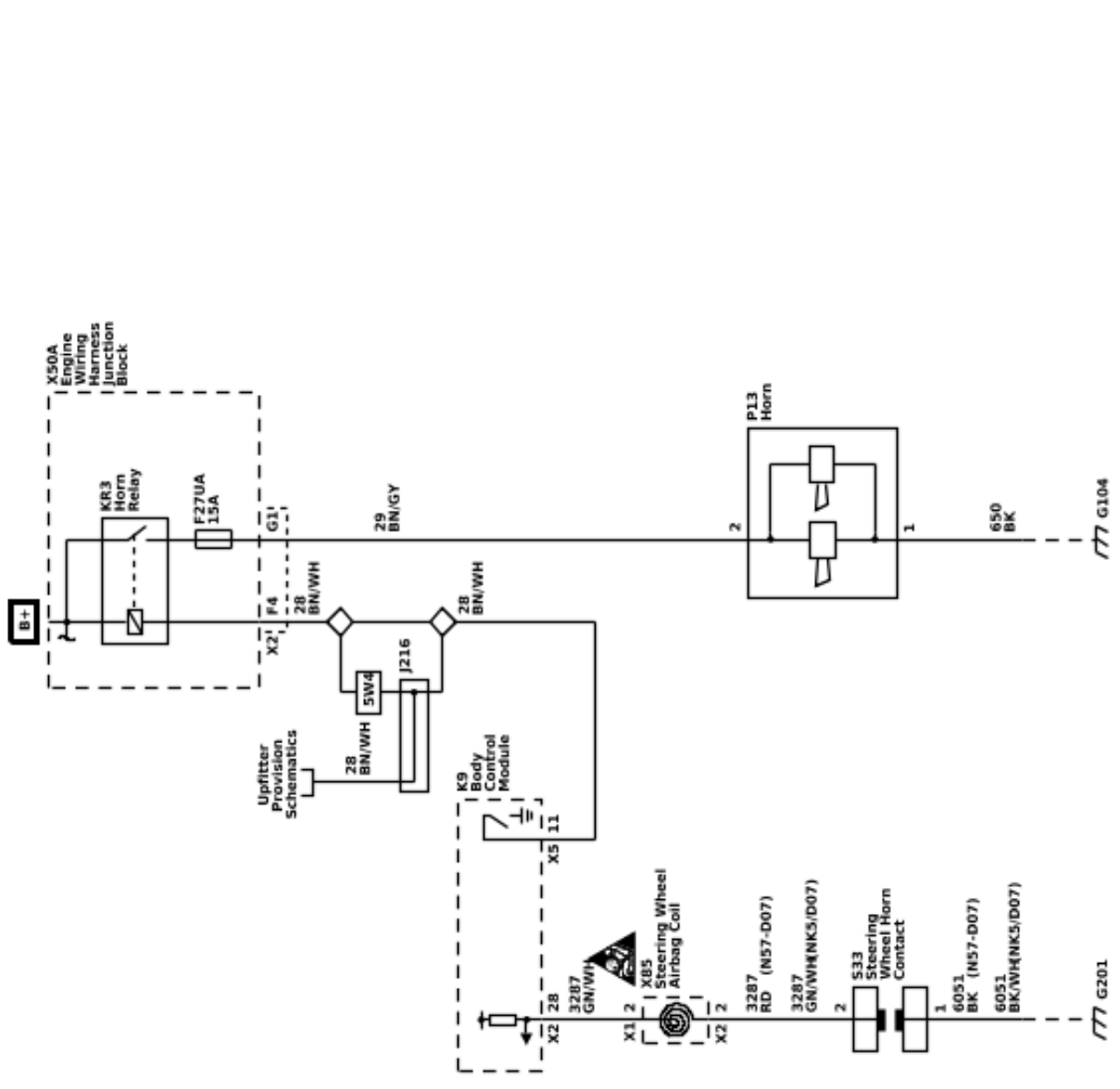

## Description and Operation

### Horns System Description and Operation

#### System Description

The horn system consists of the following components:

- HORN fuse
- Engine wiring harness junction block (contains horn PCB relay)
- Steering wheel horn contact
- Steering wheel airbag coil
- Horn
- Body control module (BCM)

#### System Operation

The vehicle horn system is activated under the following conditions:

- When the horn switch is depressed
- The BCM commands the horns ON under any of the following conditions:
  - When the content theft deterrent system detects a vehicle intrusion.
  - When the panic button is depressed on the remote control door lock transmitter—For further information refer to Keyless Entry System Description and Operation.
  - When the keyless entry system is used to lock the vehicle, a horn chirp may sound to notify the driver that the vehicle has been locked. The notification feature may be enabled or disabled through personalization. For further information refer to Keyless Entry System Description and Operation.
  - When the OnStar<sup>®</sup> system is used to sound the horns if equipped—For further information, refer to OnStar Description and Operation.

#### Circuit Operation

Battery positive voltage is applied at all times to the horn relay coil and the horn relay switch. Pressing either of the horn switches applies ground to the horn relay control circuit. The BCM may also apply ground to the horn relay control circuit as described above. When the horn relay control circuit is grounded, the horn relay is energized and battery positive voltage is applied to the horns through the horn control circuit. The horns sound as long as ground is applied to the horn relay control circuit.

# Lighting

## Schematic and Routing Diagrams

Headlights/Daytime Running Lights (DRL) Schematics (Controls and Indicators)

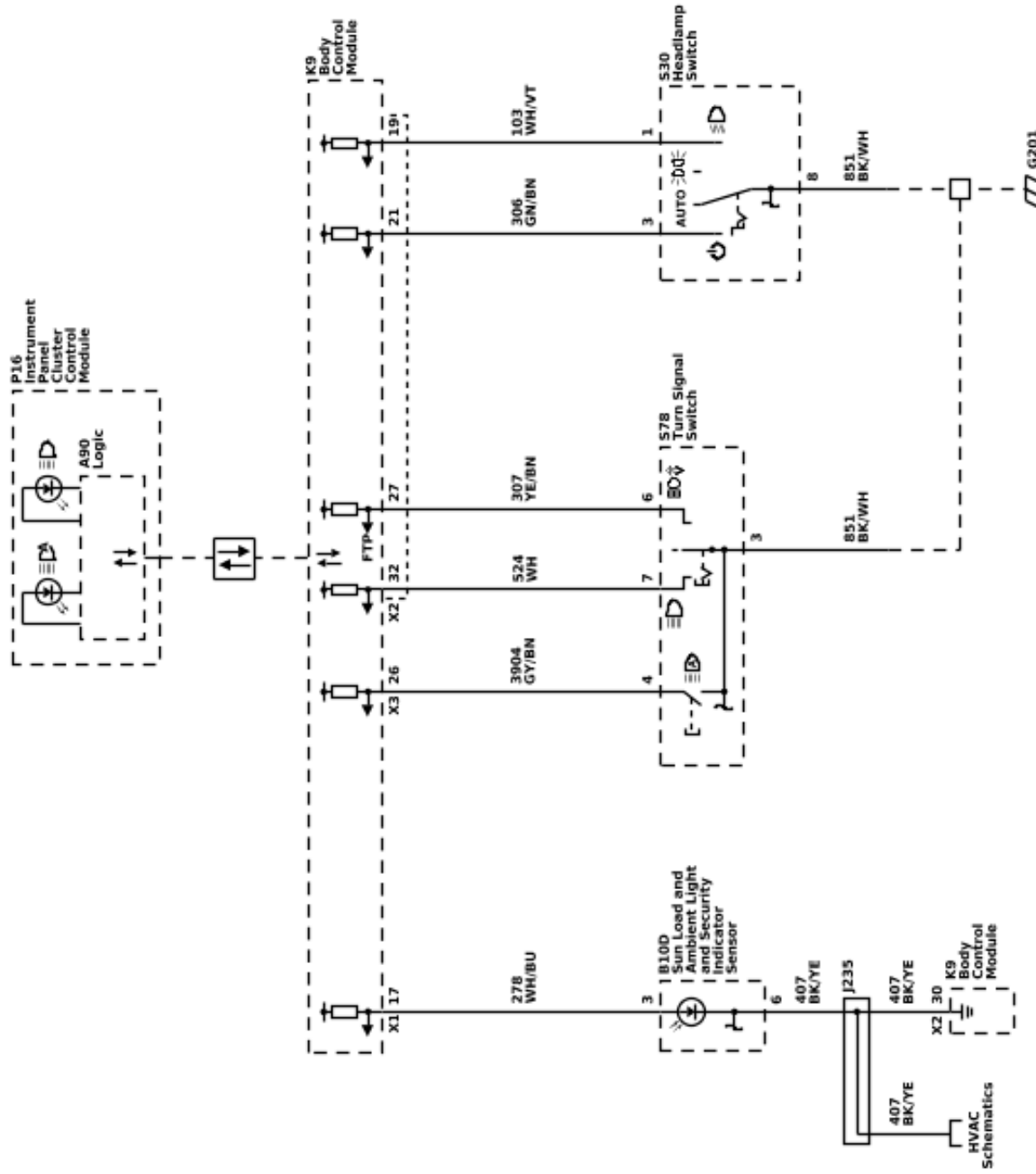
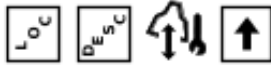

6278752



Headlights/Daytime Running Lights (DRL) Schematics (Headlamps (GF2 / GF5 / GPZ))

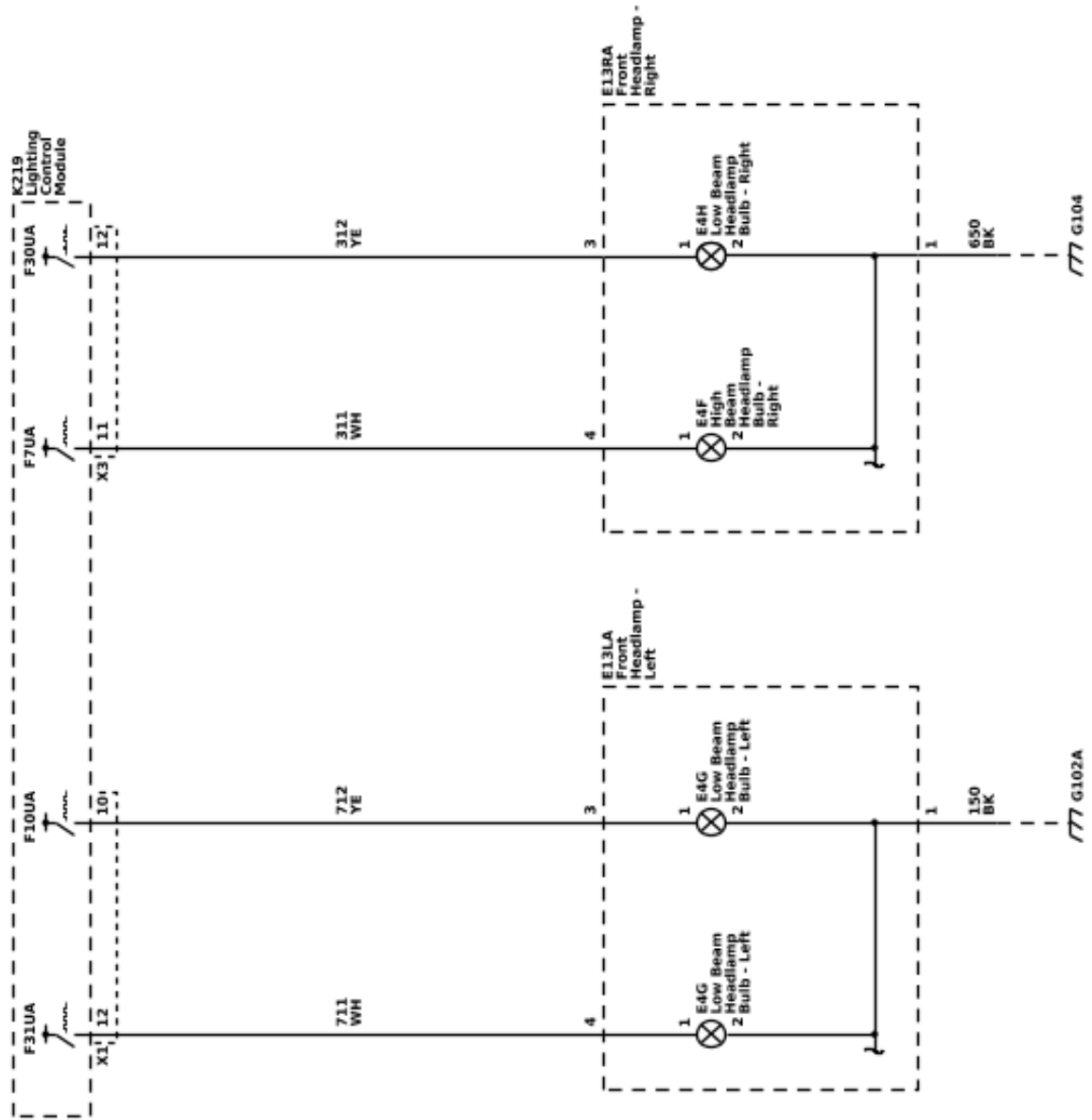



Headlights/Daytime Running Lights (DRL) Schematics (Headlamps and Daytime Running Lamps - Right (GF3 / GF4 / GF9 / GF9 / GFC / GFD / GG0 / GRZ))

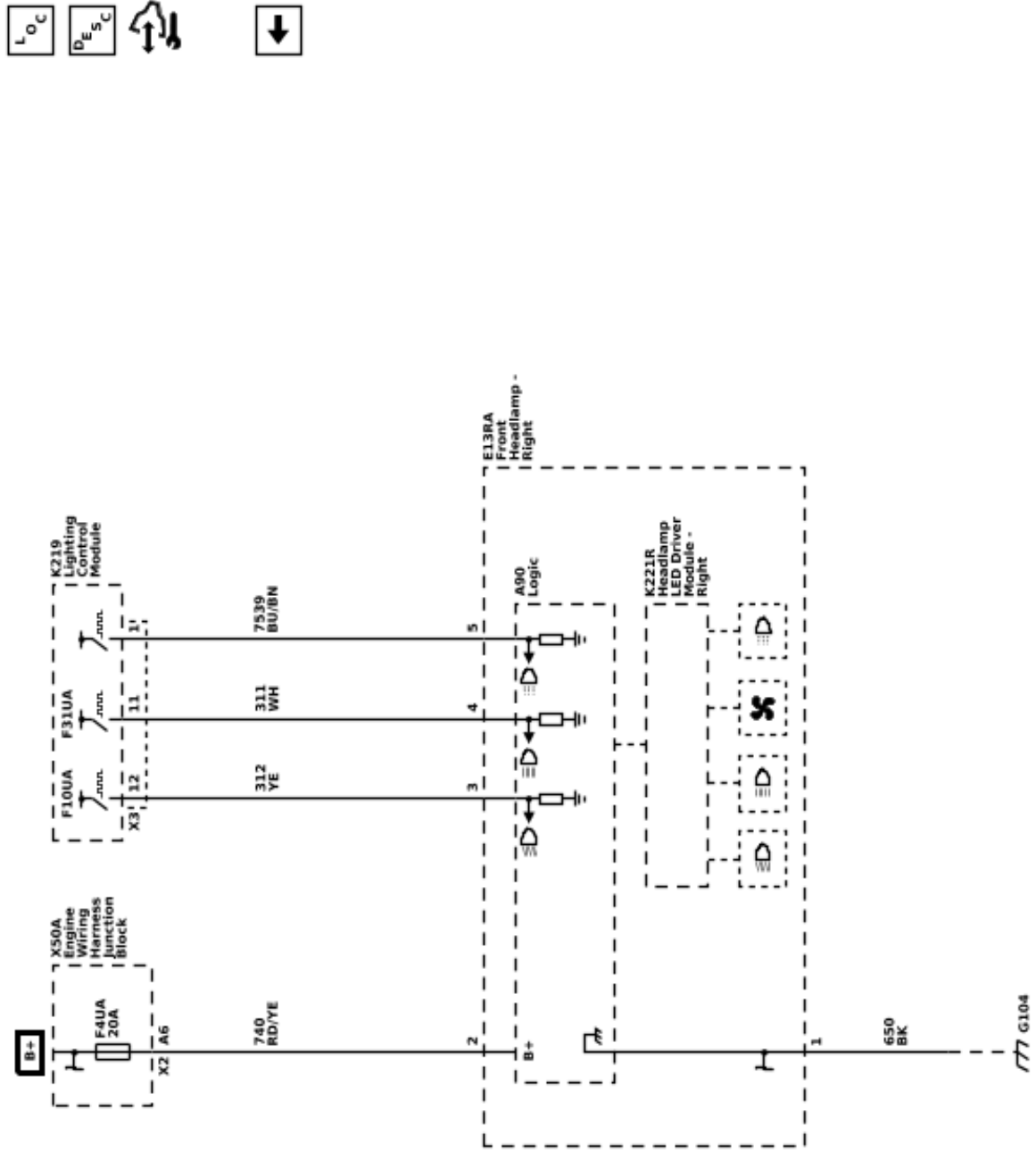

6278755

Fog Lights Schematics (Fog Lamps (T3U))

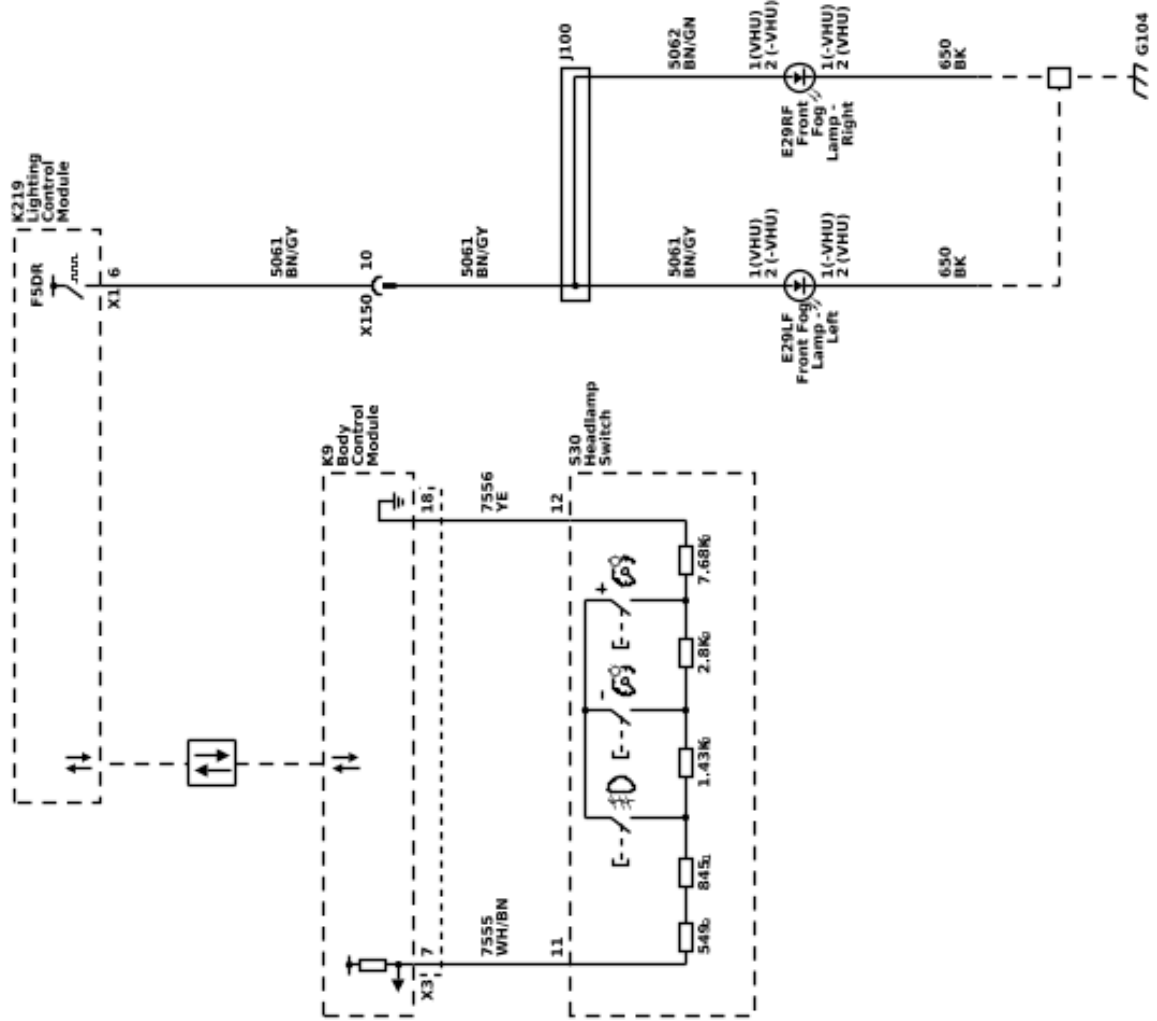



Exterior Lights Schematics (Lighting Control Module Subsystem References)

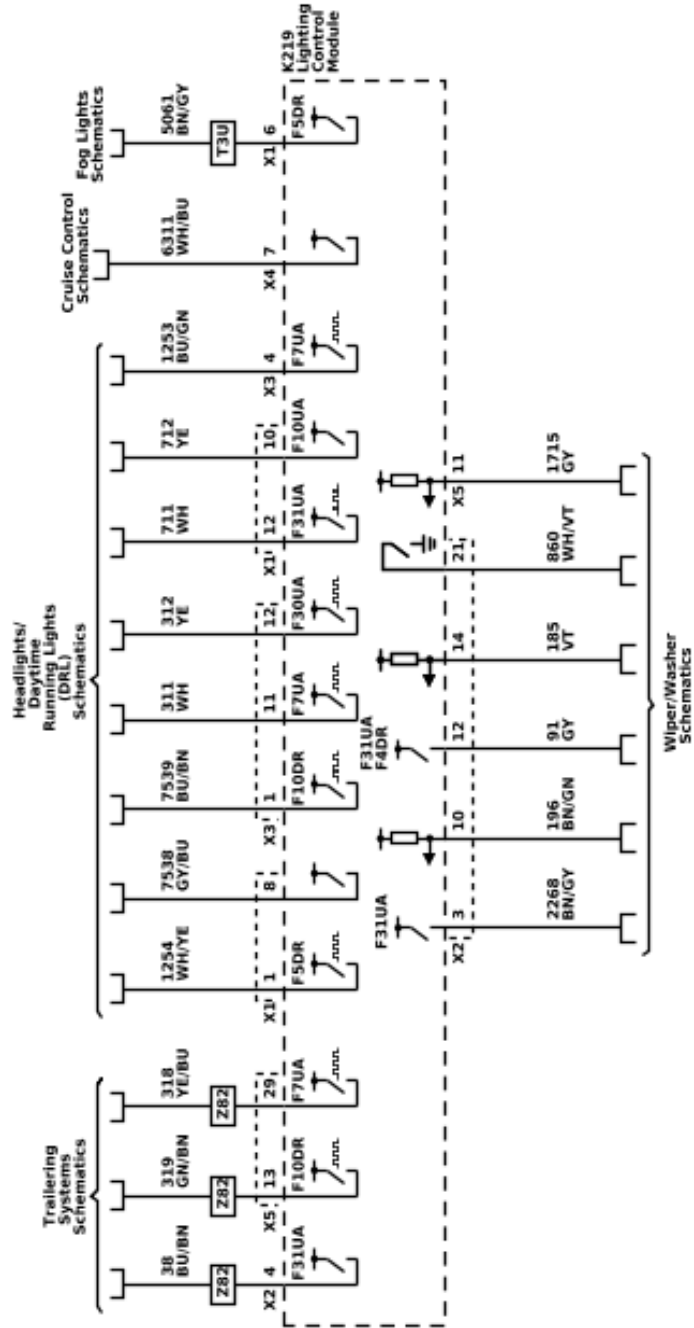

Exterior Lights Schematics (Controls and Indicators)

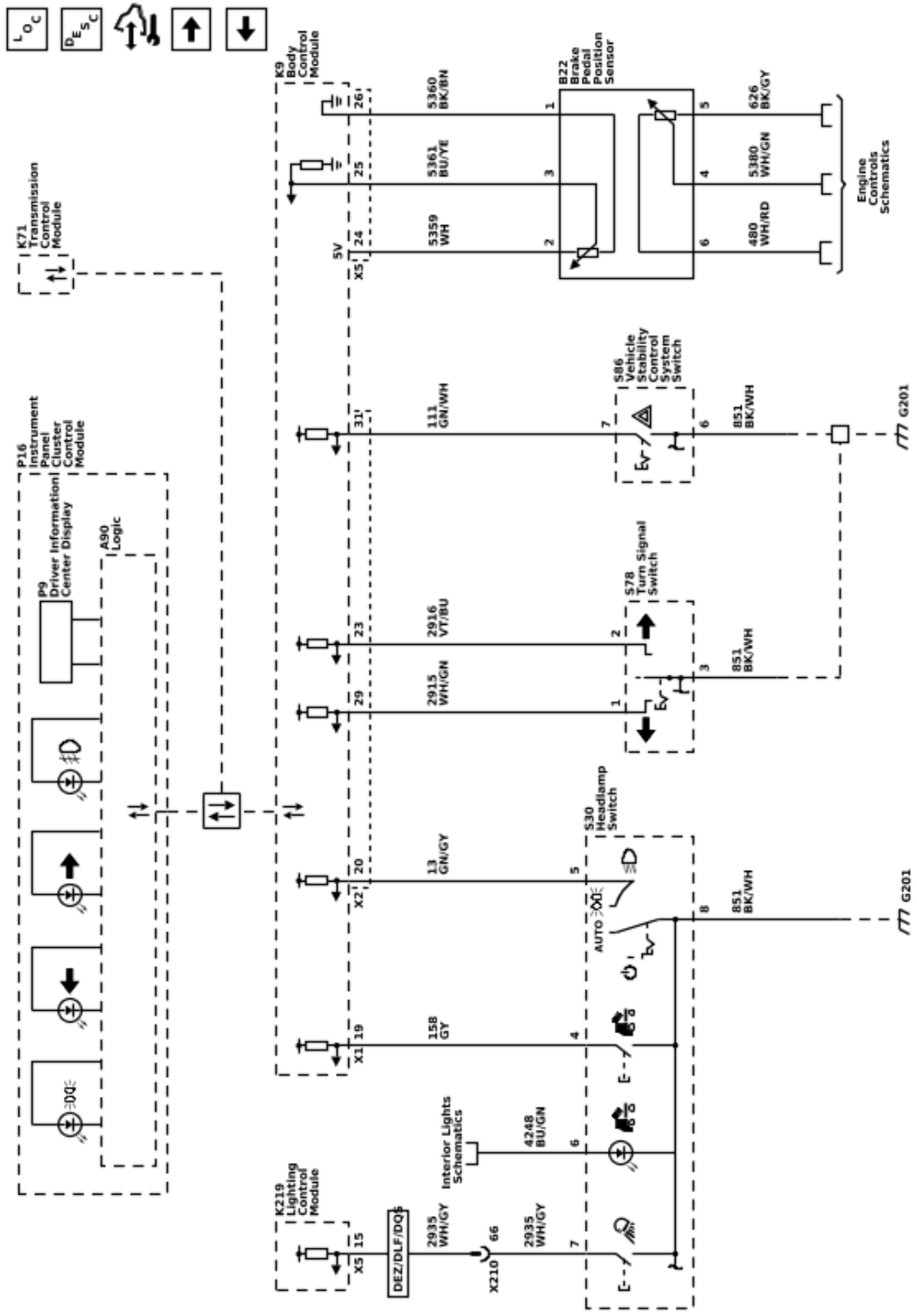

Exterior Lights Schematics (Front Lights)

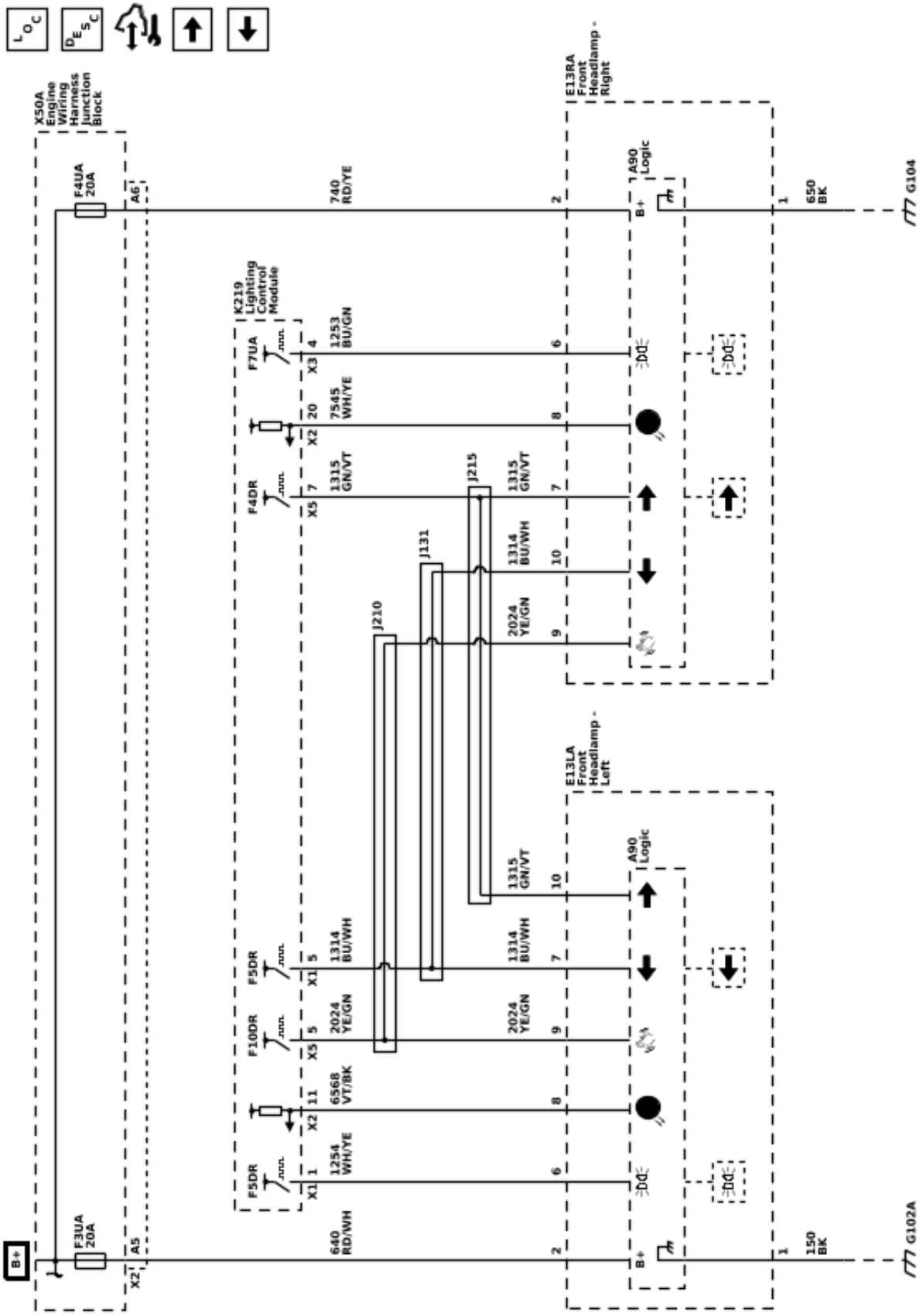

6278760





Exterior Lights Schematics (Right Rear Body Structure Stop Lamp and Right Cargo Box Lamp (GF2 / GF3 / GF5 / GG0 / GPZ))

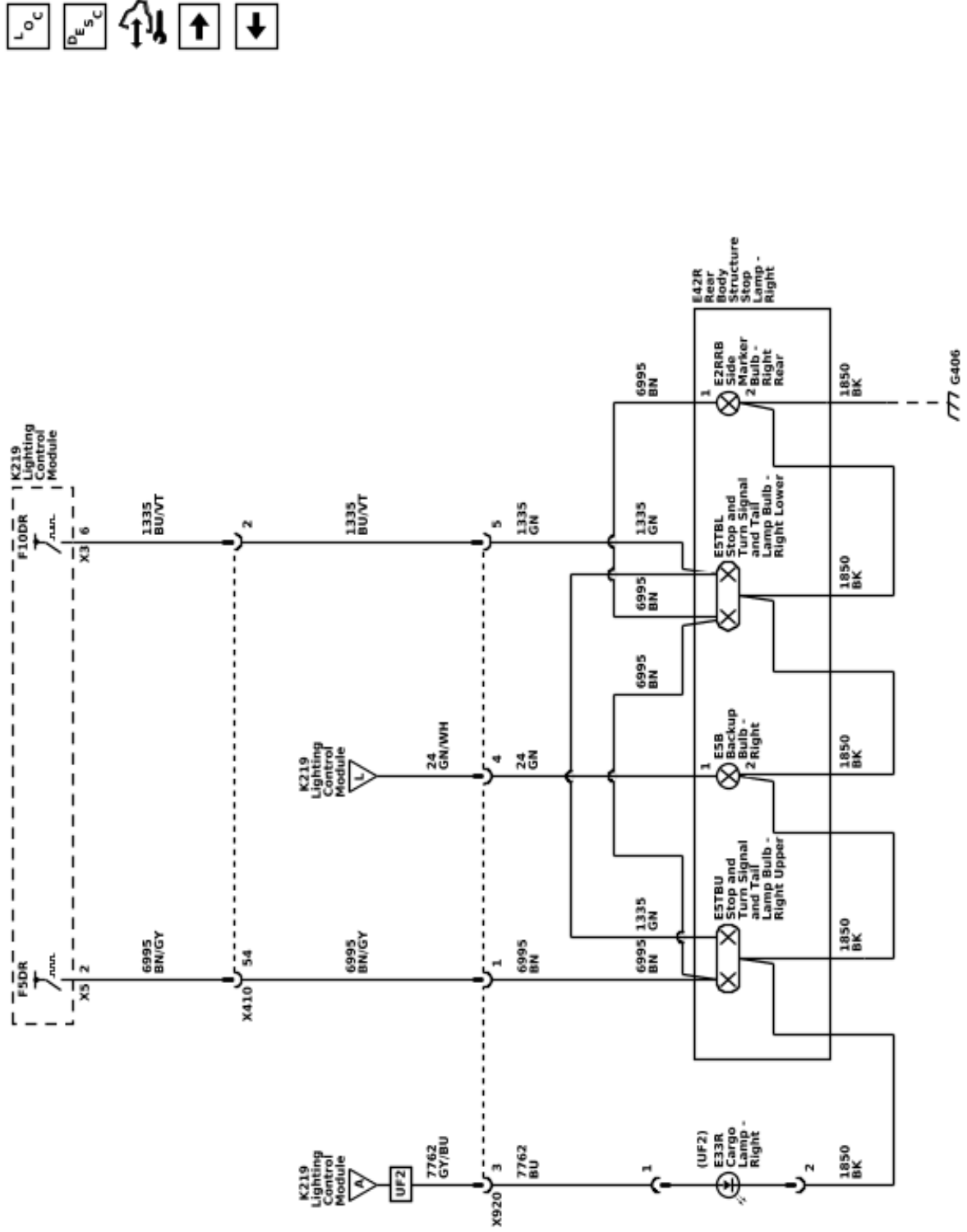

6278762

Exterior Lights Schematics (Left Rear Body Structure Stop Lamp, Left Cargo Box Lamp, and Backup Signal (GF4 / GF9 / GFC / GFD / GRZ))

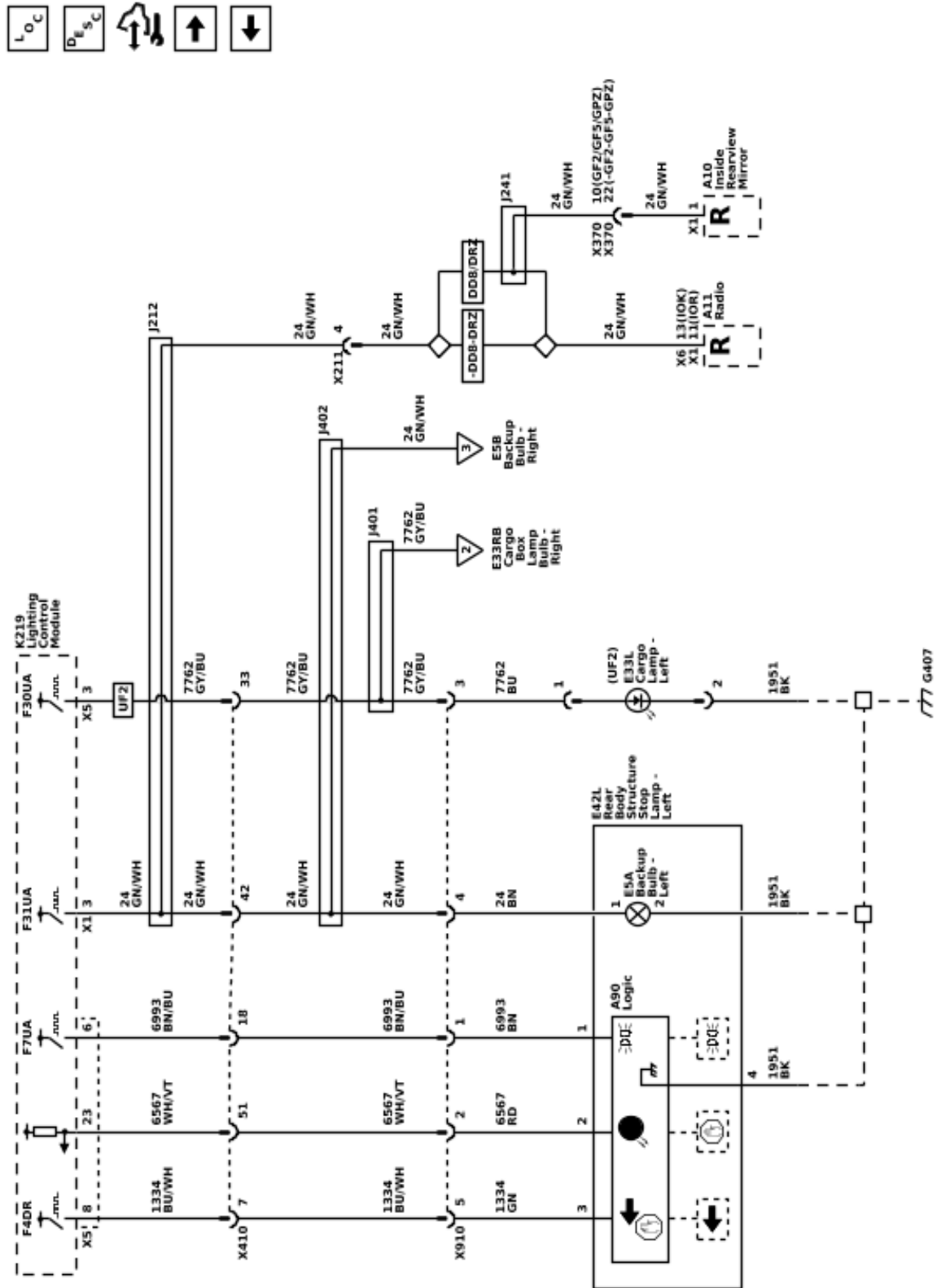

Exterior Lights Schematics (Right Rear Body Structure Stop Lamp and Right Cargo Box Lamp (GF4 / GF9 / GFC / GFD / GRZ))

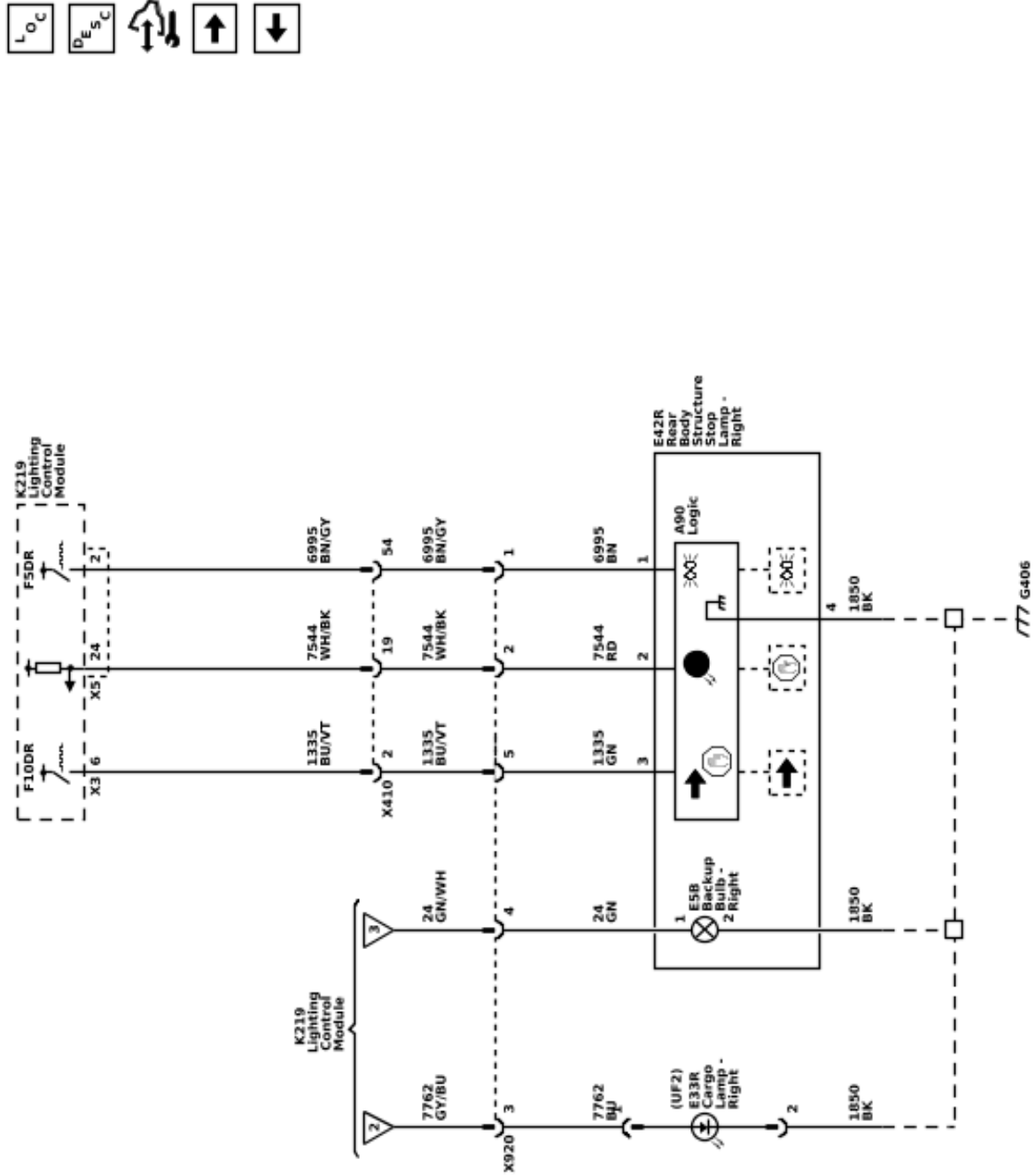

Exterior Lights Schematics (Center High Mount Stop and Exterior Courtesy Lights - Regular Cab)

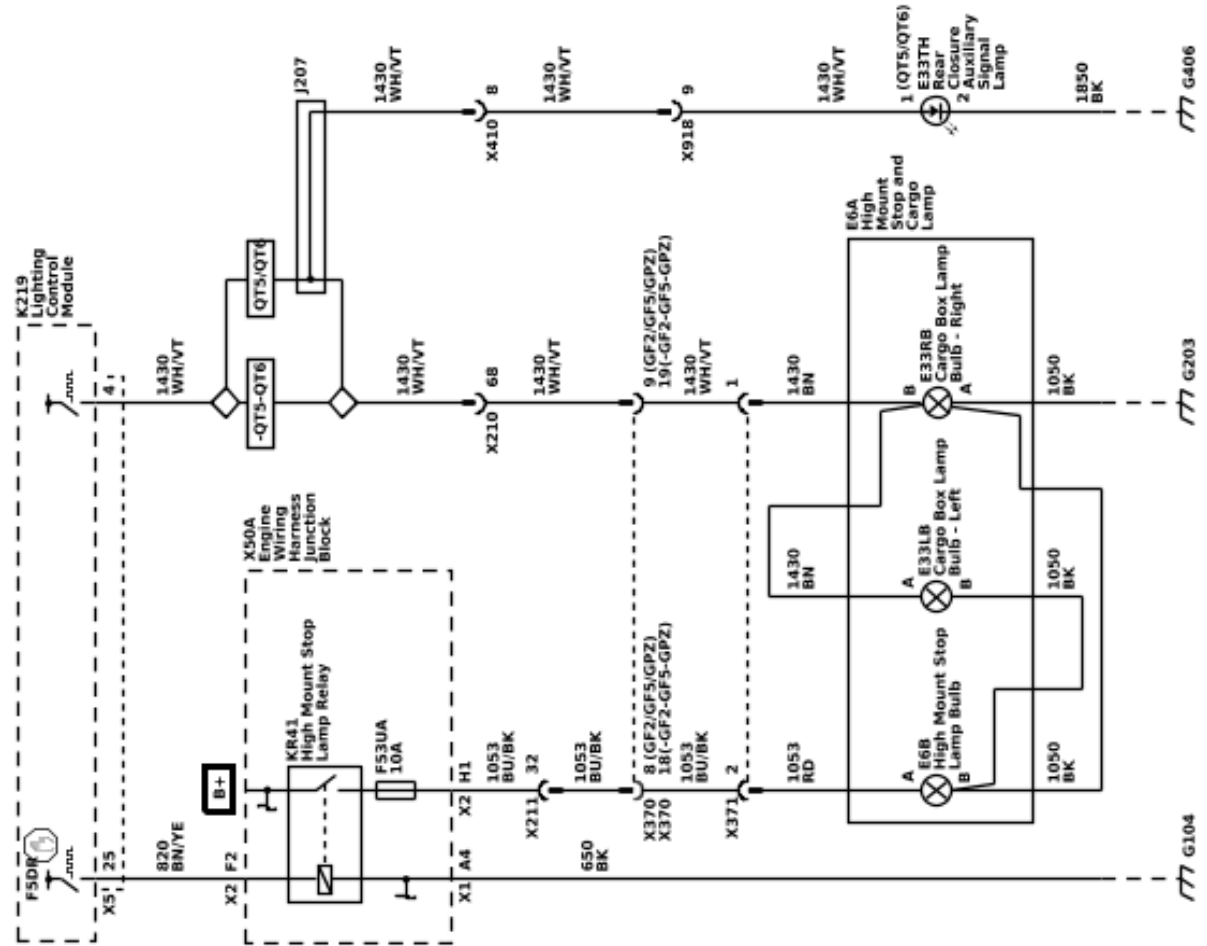

Exterior Lights Schematics (Center High Mount Stop and Exterior Courtesy Lights - Extended Cab/Crew Cab)

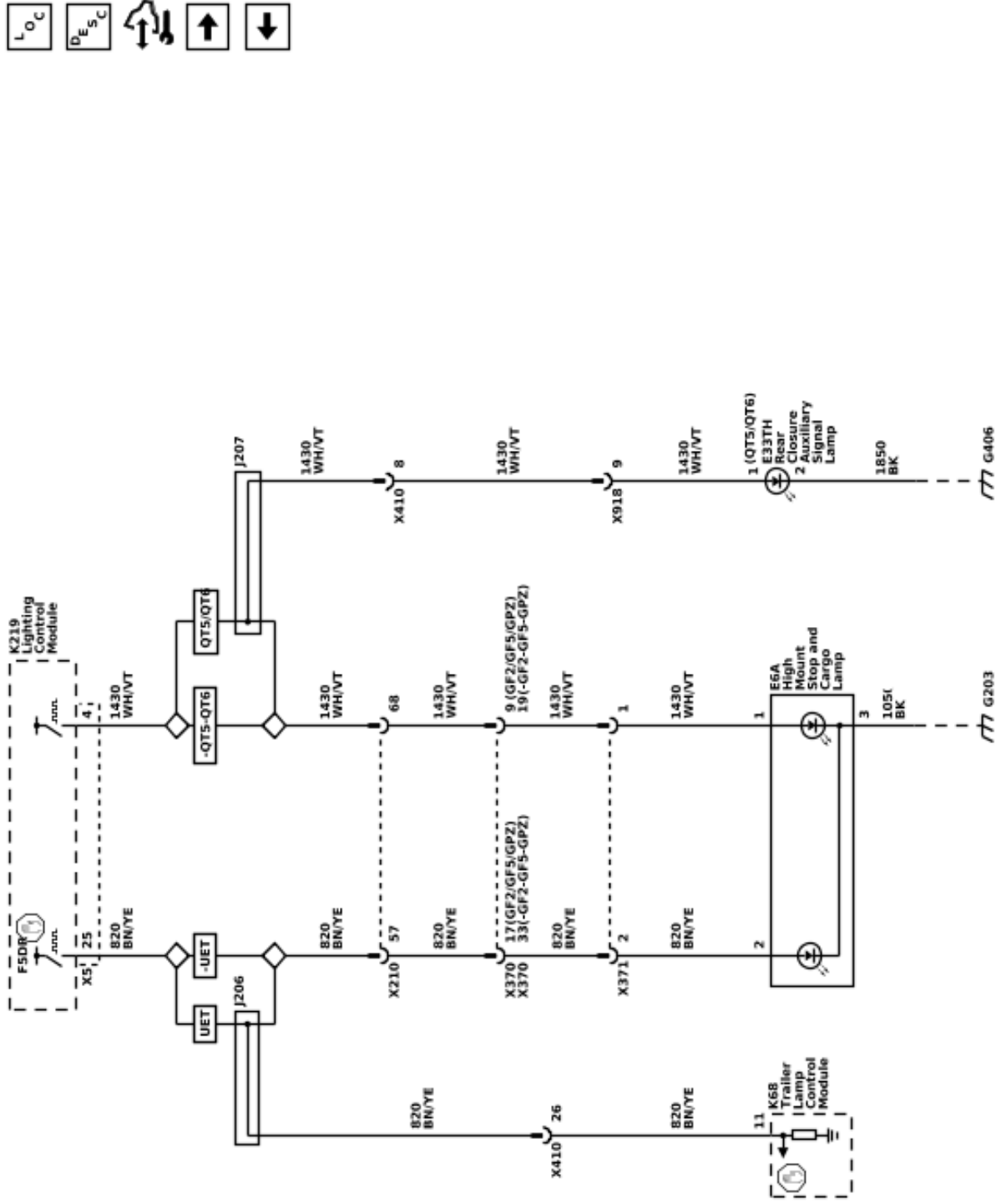

Exterior Lights Schematics (Outside Rearview Mirror Task, Turn, Approach, and Flood Lights (DEZ / DLF / DPO / DQS))

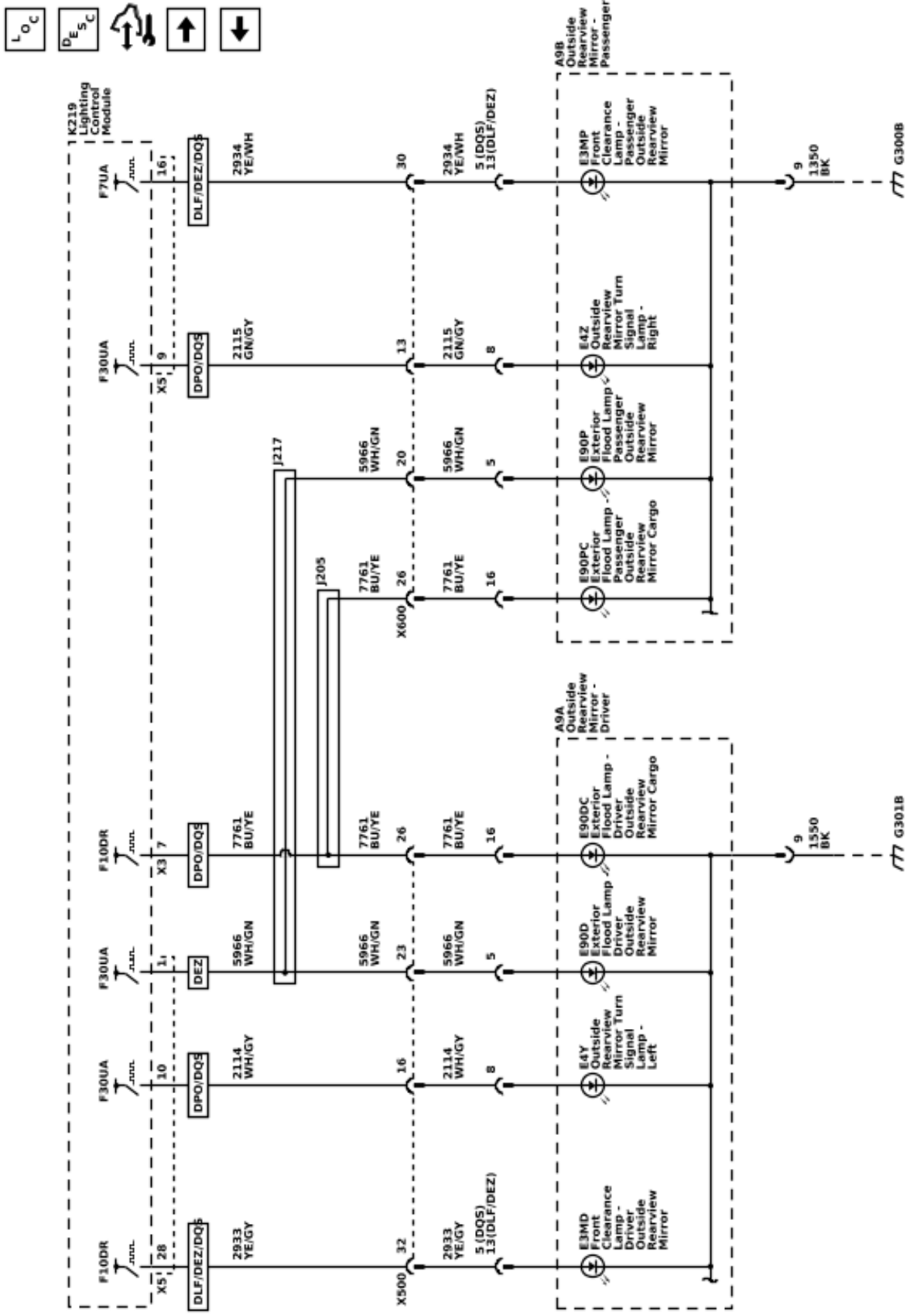

6278767

Exterior Lights Schematics (Identification Lights (DPO / DQS / GRZ))

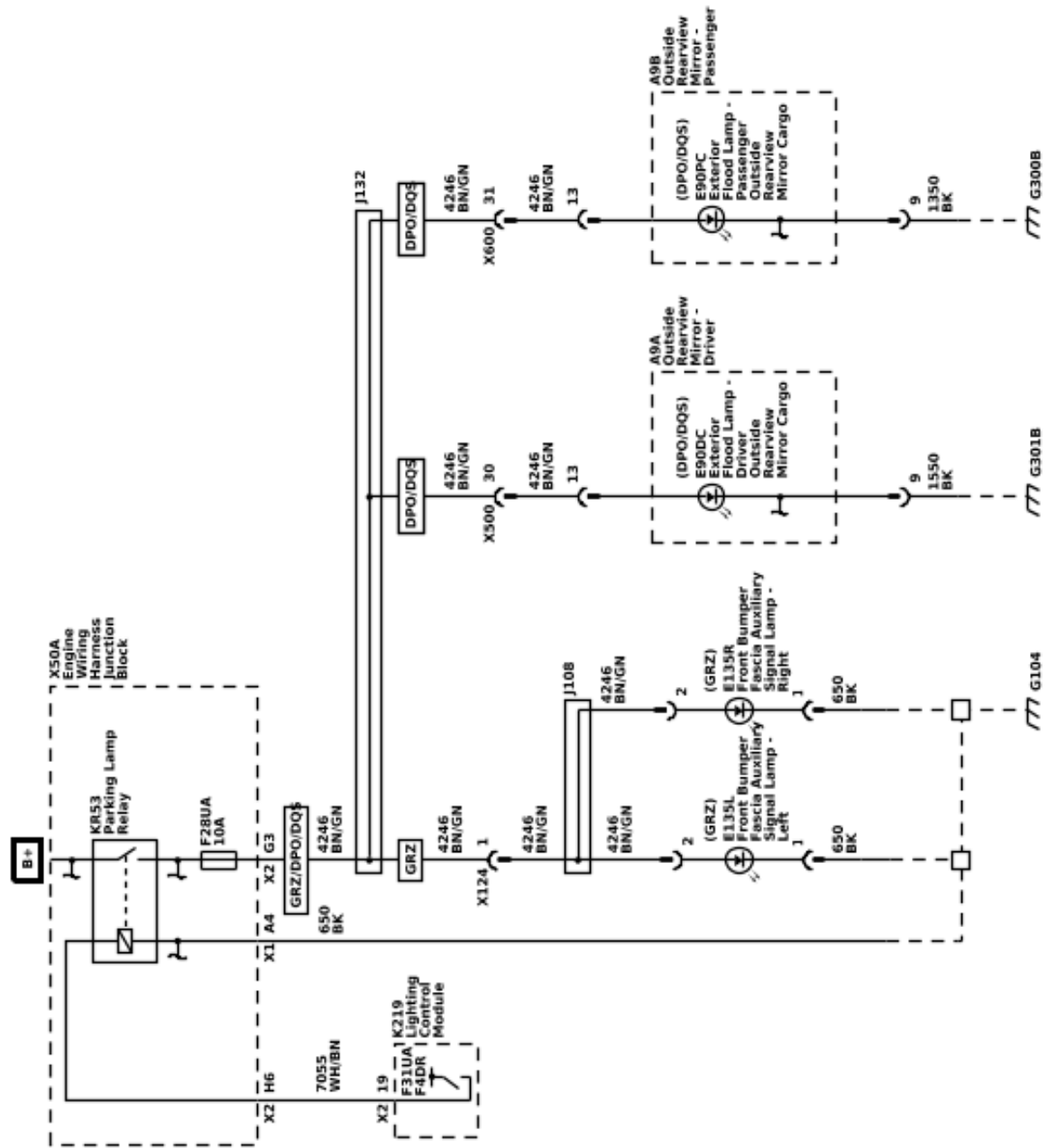



Exterior Lights Schematics (License Plate Lamps)

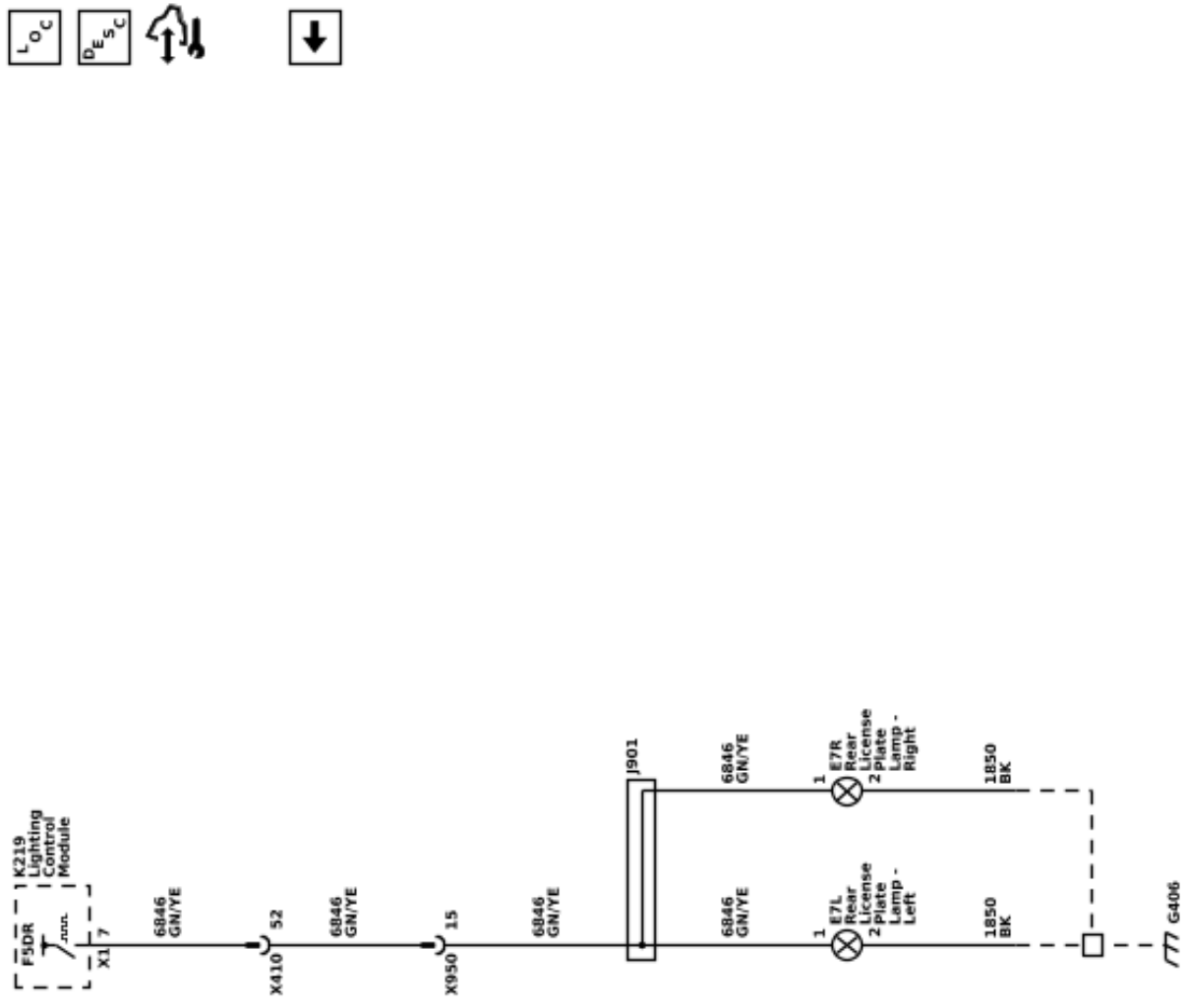





Interior Lights Dimming Schematics (Controls and Front Door Backlights)

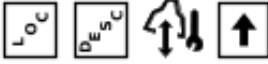
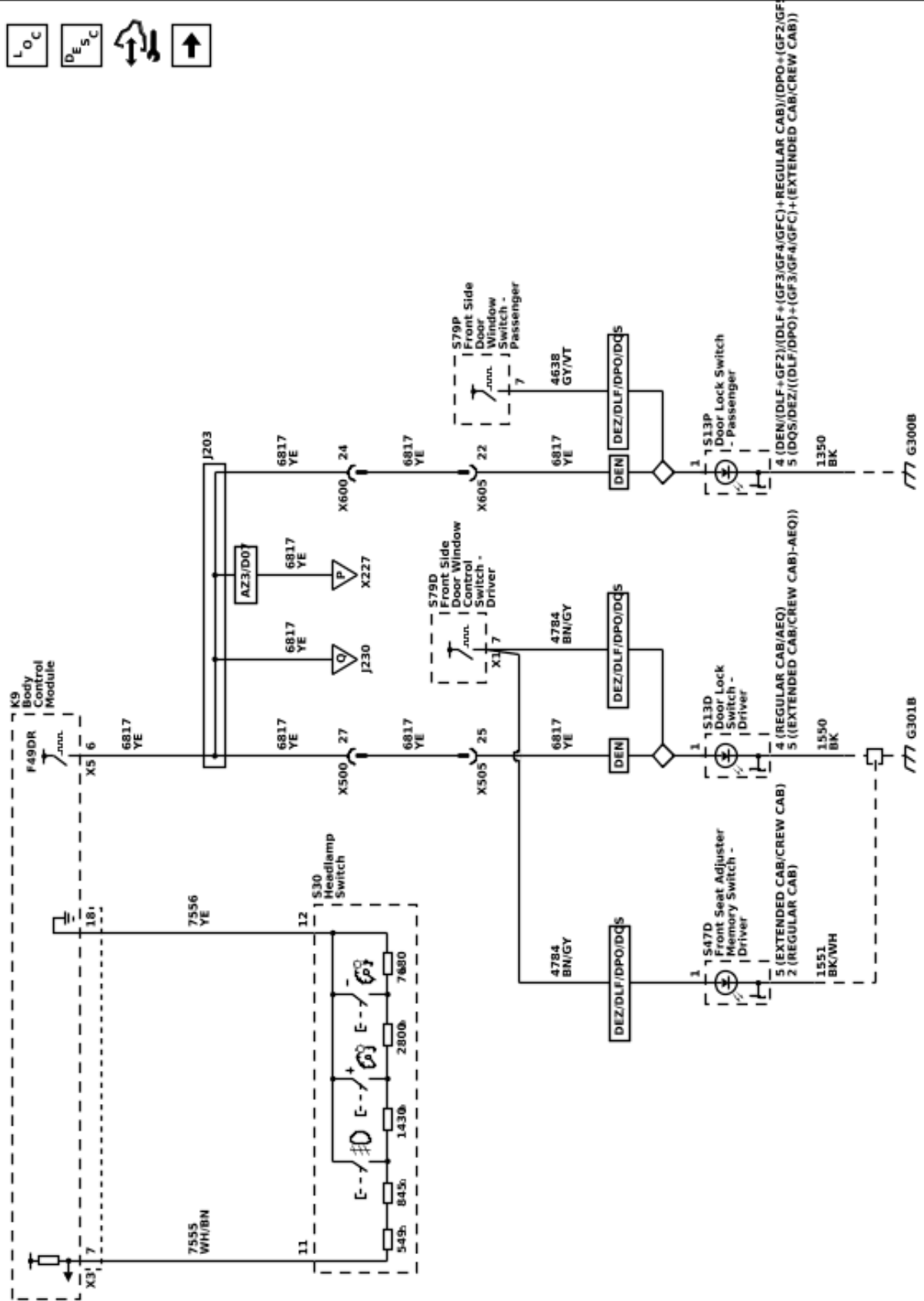



Interior Lights Dimming Schematics (Instrument Panel Backlights)

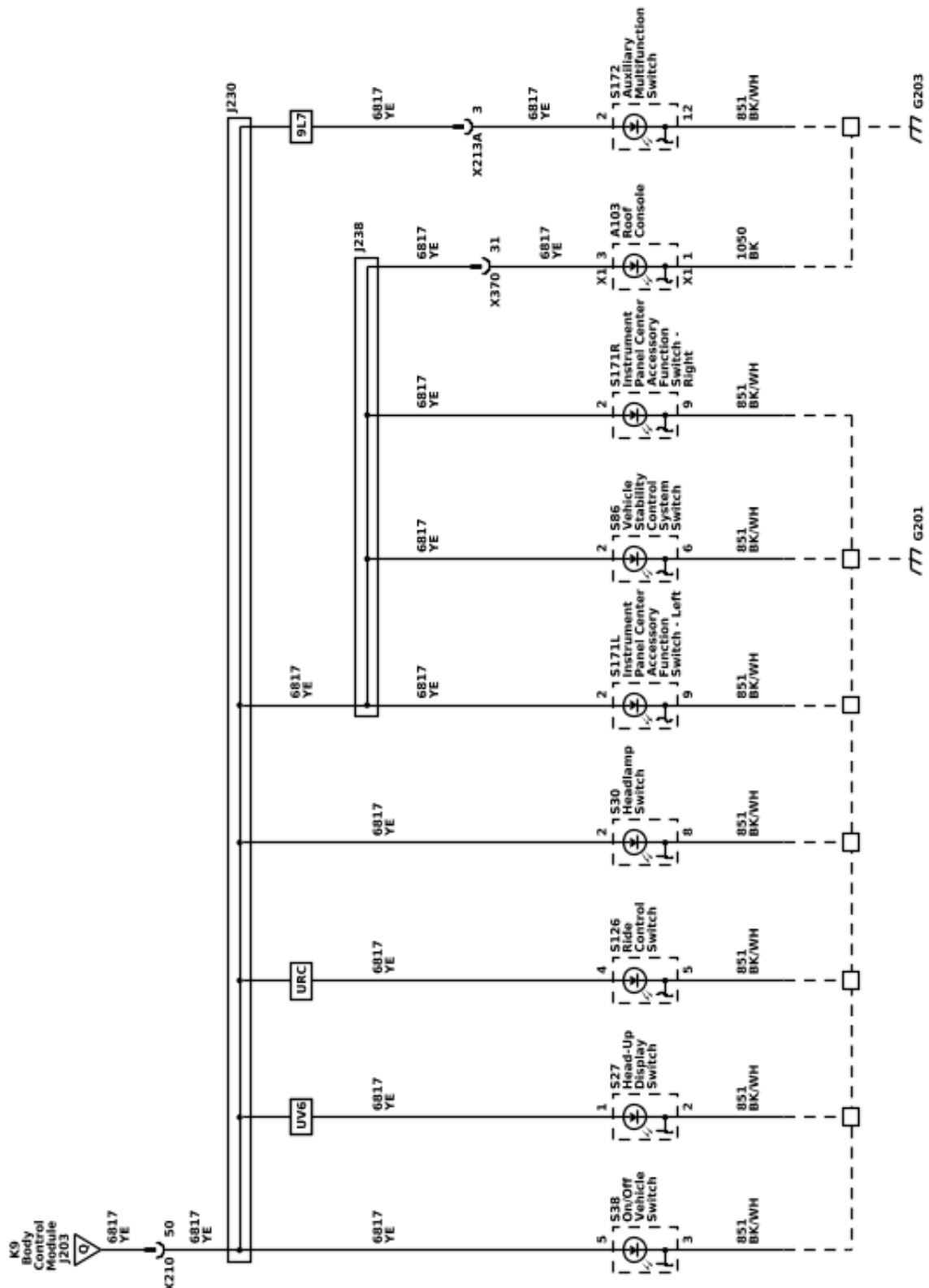



## Description and Operation

### Exterior Lighting Systems

#### Description and Operation

The exterior lighting system consist of the following lamps:

- Backup lamps
- Cargo lamps
- Daytime running lamps (DRL)
- Exterior courtesy lamps
- Hazard warning lamps
- Headlamps
- Park, tail, license, and marker lamps
- Front fog lamps (T3U)
- Stop lamps
- Task lamps
- Turn signal lamps
- Trailer lighting, refer to [Trailer Description and Operation on page 2-63](#) for more information.

#### Low Beam Headlamps

The headlamps may be turned ON in 3 different ways:

- When the headlamp switch is placed in the ON position, for normal operation
- When the headlamp switch is placed in the AUTO position, for automatic lamp control during low ambient light conditions
- When the headlamp switch is placed in the AUTO position, with the windshield wipers ON in daylight conditions, after a 6 second delay

The K9 Body Control Module (BCM) monitors three signal circuits from the S30 Headlamp Switch. When the headlamp switch is in the AUTO position, the three signal circuits are unaffected (open) and the BCM relies on the B10D Sun Load and Ambient Light and Security Indicator Sensor input to determine if headlamps are required or if daytime running lamps will be activated based on outside lighting conditions. When the headlamp switch is placed in the headlamp OFF position, the headlamp switch headlamps OFF signal circuit is grounded, indicating to the BCM that the exterior lamps should be turned OFF. With the headlamp switch in the PARK LAMPS position, the headlamp switch park lamps ON signal circuit is grounded, indicating that the park lamps have been requested. When the headlamp switch is in the HEADLAMP position, both the headlamp switch park lamps ON signal circuit and the headlamps ON signal circuit are grounded. The BCM responds to these inputs by sending a serial data message to the K219 Lighting Control Module. The Lighting Control Module responds by applying pulse width modulated (PWM) voltage to both headlamp low beam control circuits, illuminating the low beam headlamps. When the Lighting Control Module commands the low beam headlamps ON, the operator will notice the interior backlighting for the instrument cluster and the various other switches dim to the level of brightness selected by the instrument panel dimmer switch.

#### High Beam Headlamps

The high beam and flash to pass (FTP) functions are contained within the S78 Turn Signal Switch. The K9 Body Control Module (BCM) provides the turn signal/multifunction switch with two signal circuits, the high beam signal circuit and the FTP signal circuit. When the low beam headlamps are ON, and the turn signal/multifunction switch is placed in either the high beam position or FTP position, ground is applied to the BCM through the high beam/FTP signal circuit. The BCM responds to the high beam request by sending a serial data message to the K219 Lighting Control Module. The Lighting Control Module responds by applying pulse width modulated (PWM) voltage to both headlamp high beam control circuits, illuminating the high beam headlamps. The status of the high beam lamps is shown by a blue indicator located on the instrument cluster. When high beams are commanded on, the indicator will be illuminated continuously. If the driver turns the high beams off, the indicator will also turn off.

#### Flash to Pass

When the S78 Turn Signal Switch is momentarily placed in the flash to pass position, ground is applied to the turn signal/multifunction switch. The turn signal/multifunction switch applies ground to the K9 Body Control Module (BCM) through the flash to pass switch signal circuit. The BCM responds to the flash to pass request by sending a serial data message to the K219 Lighting Control Module. The Lighting Control Module responds by applying pulse width modulated (PWM) voltage to both headlamp high beam control circuits, illuminating the high beam headlamps. This causes the high beam headlamps to illuminate at full brightness until the turn signal/multifunction switch is returned to the at rest position.

#### Automatic Headlamp Control

The K9 Body Control Module (BCM) monitors three signal circuits from the S30 Headlamp Switch. When the headlamp switch is in the AUTO position, the three signal circuits are unaffected (open) and the BCM relies on the B10D Sun Load and Ambient Light and Security Indicator Sensor input to determine if headlamps are required or if daytime running lamps will be activated based on outside lighting conditions. During automatic lamp control, the headlamps will be off during daylight conditions but will turn on when the ambient light sensor detects low ambient light conditions. The ambient light sensor is a light sensitive transistor that varies the voltage signal to the BCM. The BCM provides a 5 volt reference signal and a low reference ground to the ambient light sensor. During low light conditions the BCM will request the low beam headlamps ON by sending a serial data message to the K219 Lighting Control Module. The Lighting Control Module responds by applying pulse width modulated (PWM) voltage to both headlamp low beam control circuits, illuminating the low beam headlamps.

#### IntelliBeam – Automatic High Beam Assist (TQ5)

The IntelliBeam system is activated by pressing the auto high beam assist button on the turn signal switch while the exterior lamp control is in AUTO mode and



the engine running. The AHBA system consists of a front camera module that detects light, and is able to identify approaching vehicles on an even, straight road at a distance of greater than 0.4 km (0.25 mi). The front camera module analyzes light color, intensity, and movement. The AHBA system will turn OFF the high beam headlamps when approaching vehicle headlamps or preceding vehicle taillights are detected by the front camera module. The AHBA system is turned off anytime the headlamp switch is moved out of the AUTO position.

### AHBA System Activation

- Vehicle ON
- Headlamp switch placed in the AUTO position
- Outside lighting conditions must be dark
- Vehicle speed greater than 25 mph (40 km/h)

### AHBA System Operation

The following are conditions that the AHBA system will turn the high beam headlamps off during operation:

- The system detects approaching traffic headlamps
- The system detects preceding traffic tail lamps
- Ambient light level too high due to towns or twilight situations
- The vehicle's speed drops below 13 mph (22 km/h)
- Delay

**Note:** AHBA may not operate properly if any of the following conditions exist:

- Approaching and preceding vehicles lamps are undetectable due to dirt, snow, road spray, smoke, fog, or any other airborne conditions.
- The front camera module is covered with ice, dirt, snow, haze, or is obstructed.
- The vehicle is being driven on winding or hilly road conditions which would make any on coming vehicle headlamps undetectable by the AHBA.

### AHBA System Deactivation

- Manually operating the headlamp switch from neutral to high beam position
- AHBA is deactivated automatically when the front or rear fog lamps are turned ON

### AHBA System Indicator

The status of the AHBA system is shown by a green indicator located on the instrument panel cluster. When AHBA is active, the indicator will be illuminated continuously. If the operator deactivates the AHBA system, the indicator will turn off.

## Daytime Running Lamps

The daytime running lamps (DRL) will illuminate continuously when the following conditions are met:

- Engine running
- The headlamp switch is in the AUTO position
- Ambient light conditions are daytime conditions

The B10D Sun Load and Ambient Light and Security Indicator Sensor is used to monitor outside lighting conditions. The ambient light sensor provides a voltage signal that will vary between 0.2 and 4.9 volts

depending on outside lighting conditions. The K9 Body Control Module (BCM) provides a 5 volt reference signal and a low reference ground to the ambient light sensor. The BCM monitors the ambient light sensor signal circuit to determine if outside lighting conditions are correct for either daytime running lamps (DRL) or automatic lamp control when the headlamp switch is in the AUTO position. In daylight conditions the BCM will send a serial data message to the K219 Lighting Control Module to command the DRLs ON, the Lighting Control Module responds by applying pulse width modulated (PWM) voltage to both DRL control circuits, illuminating the DRLs. During low light conditions the Lighting Control Module will command the low beam headlamps ON.

## Hazard Lamps

The hazard flashers may be activated in any power mode. The Hazard Warning Switch signal circuit is momentarily grounded when the hazard switch is pressed. The K9 Body Control Module (BCM) responds to the hazard switch signal input by sending a serial data message to the K219 Lighting Control Module. The Lighting Control Module responds by supplying battery voltage to all turn signal lamps in an ON and OFF duty cycle. When the hazard switch is activated, the BCM also sends a serial data message to the instrument cluster requesting both turn signal indicators to be cycled ON and OFF.

## Park, Tail, and License Lamps

When the S30 Headlamp Switch is placed in the HEAD or PARK position, ground is applied to the park lamp switch ON signal circuit to the K9 Body Control Module (BCM). The BCM responds to the park lamp switch signal input by sending a serial data message to the K219 Lighting Control Module. The Lighting Control Module responds by applying battery voltage to the park lamps, tail lamps, and license lamps control circuits illuminating the park, tail, and license lamps.

## Stop Lamps

The B22 Brake Pedal Position Sensor is used to sense the action of the driver application of the brake pedal. The K9 Body Control Module (BCM) provides the brake pedal position sensor with low reference, signal, and 5 volt reference circuits. When the variable signal reaches a voltage threshold indicating the brakes have been applied, the BCM will respond by sending a serial data message to the K219 Lighting Control Module requesting the stop lamps to be turned ON. The Lighting Control Module responds by applying battery voltage to the left and right stop lamp control circuits as well as the center high mounted stop lamp control circuit illuminating the left and right stop lamps and the center high mounted stop lamp. If serial data communication is lost between the BCM and the Lighting Control Module, the Lighting Control Module will receive a serial data message from the Electronic Brake Control Module indicating that the brakes have been applied. If serial data communication is lost between all three modules, the Lighting Control Module also receives a hard wired voltage signal from the BCM to signal the brake lamps ON.

## Turn Signal Lamps

### Turn Signals

The K9 Body Control Module (BCM) provides the S78 Turn Signal Switch with left and right turn signal switch signal circuits. Ground is applied at all times to the turn signal/multifunction switch. The turn signal lamps may only be activated with the ignition switch in the ON or START positions. When the turn signal/multifunction switch is placed in either the turn right or turn left position, ground is applied to the BCM through either the right turn or left turn signal switch signal circuit. The BCM responds to the turn signal switch input by sending a serial data message to the K219 Lighting Control Module. The Lighting Control Module responds by applying a pulsating voltage to the turn signal lamps through their respective control circuits. When a turn signal request is received by the BCM, a serial data message is also sent to the instrument cluster requesting the respective turn signal indicator be pulsed ON and OFF.

### Turn Signal Outage Detection

Vehicles with LED turn signals require additional turn signal outage detection circuits that provide turn signal feedback to the K219 Lighting Control Module. The Lighting Control Module uses the feedback information to send a serial data message to the instrument cluster to alert the driver anytime a turn signal fault is detected. If a fault is detected on a turn signal circuit or a turn signal feedback circuit, the turn signals will flash in a rapid manner to alert the driver of the fault.

### Turn Signal Animation

When the K219 Lighting Control Module receives a serial data message from the K9 Body Control Module (BCM) that the turn signals are being commanded on, the lighting control module responds by applying a pulsating voltage to the front, mirror, and rear turn signal lamps through their respective control circuits. Both front turn signal control circuits are connected to each headlamp assembly, this is for animation purposes. When a headlamp assembly only receives one turn signal input, an animation effect takes place as a “swiping” motion for the front turn signals. When a headlamp assembly receives both turn signal inputs as part of the hazard lamps becoming active, the turn signals do not exhibit the animation effect and will flash without the “swiping” motion.

## Backup Lamps

With the engine running and the transmission in the reverse position, the transmission control module (TCM) sends a serial data message to the multiple control modules. The message indicates that the gear selector is in the reverse position. The K9 Body Control Module (BCM) responds to the reverse position message by sending a serial data message to the K219 Lighting Control Module to request the backup lamps on. The Lighting Control Module responds by applying battery voltage to the backup lamps control circuit(s) illuminating the backup lamps. The applied voltage is also sent to the A11 Radio and A10 Inside Rearview Mirror for rearview camera purposes. Once the driver moves the gear selector out of the reverse position, a serial data message is sent by the TCM that the transmission is no longer in the reverse position.

The BCM responds to the reverse position message by sending a serial data message to the Lighting Control Module to request the backup lamps off. The Lighting Control Module responds by removing battery voltage from the backup lamp circuits. The engine must be running for the backup lamps to operate.

## Cargo Lamps

### Cargo Lamps

When the K9 Body Control Module (BCM) receives a task lamp switch input from the S30 Headlamp Switch, the BCM responds by sending a serial data message to the K219 Lighting Control Module. The lighting control module responds by applying pulse width modulated (PWM) voltage to the cargo lamp control circuits illuminating the cargo lamps. In the event that the cargo lamps were to remain illuminated for more than 10 minutes with the ignition switch in the OFF position, the lighting control module will deactivate the cargo lamp control circuits to prevent total battery discharge.

### Task Lamps

When the K9 Body Control Module (BCM) receives a task lamp switch input from the S30 Headlamp Switch, the BCM responds by sending a serial data message to the K219 Lighting Control Module. The lighting control module responds by applying pulse width modulated (PWM) voltage to the task lamp control circuits illuminating the task lamps in each outside rearview mirror assembly. When the task lamp switch is pressed a second time, the left task lamp control circuit will stay illuminated while the right side will be turned off. When the task lamp switch is pressed a third time, the left task lamp control circuit will be turned off while the right side will be turned back on. When the task lamp switch is pressed a fourth time, both task lamps will be turned off. In the event that the task lamps were to remain illuminated for more than 10 minutes with the ignition switch in the OFF position, the lighting control module will deactivate the cargo lamp control circuit to prevent total battery discharge.

## Approach Lighting

Approach lighting is commanded ON when the unlock button is pressed on the keyless entry transmitter during dark ambient light conditions. When the keyless entry transmitter unlock button is pressed, a serial data message is sent by the K9 Body Control Module (BCM) that the vehicle is being unlocked. The K219 Lighting Control Module responds to the serial data message by applying voltage to the approach lamp control circuit illuminating the LED lighting located under each outside rearview mirror as part of approach lighting.

## Battery Run Down Protection/ Inadvertent Power

To provide battery run down protection, the exterior lamps will be deactivated automatically under certain conditions. The K9 Body Control Module (BCM) monitors the state of the S30 Headlamp Switch. If the headlamp switch is in the park or headlamp position when the ignition switch is ON and then the ignition switch is placed in the OFF position, the BCM initiates a 10 minutes timer. At the end of the 10 minutes, the BCM will send a serial data message to the K219 Lighting

Control Module to deactivate the exterior lamps to prevent total battery discharge. This feature will be cancelled if any power mode other than OFF becomes active.

The BCM will disable battery run down protection if any of the following conditions exist:

- The park or headlamp switch is changed from the ON to OFF position, and back to the ON position during battery run down protection.
- The BCM determined that the park or headlamp switch was not active when the ignition was turned OFF.

## Interior Lighting Systems Description and Operation

### Interior Lamps

#### Dome Lamps

The dome lamps are controlled by door ajar inputs to the K9 Body Control Module (BCM). When any door is opened, the door ajar switch contacts close and the BCM receives a door-open input. The BCM responds by sending a serial data message to the A103 Roof Console. The Roof Console responds by applying battery voltage to the dome lamps illuminating the dome lamps. The BCM will also send a serial data message to request the dome lamps on when a door lock/unlock request is activated with the key fob. After all doors have been closed, the dome lamp will remain illuminated approximately 3 seconds after the last door closes. In the event that the dome lamp were to remain illuminated for more than 10 minutes with the ignition switch in the OFF position, the BCM will deactivate the dome lamp control circuit to prevent total battery discharge. The dome lamps will turn OFF using the theater dimming feature when controlled by the BCM.

#### Center Console Compartment Lamp

The K9 Body Control Module (BCM) supplies battery voltage to the center console lamp through control circuit 4786 anytime the ignition/vehicle is turned on or the dome lamps are requested on through the dome lamp control switch on the A103 Roof Console. In the event that the center console lamp were to remain illuminated for more than 10 minutes with the ignition/vehicle off, the BCM will deactivate the courtesy lamp control circuit to prevent total battery discharge.

#### Keyless Entry Interior Illumination

When the operator uses the keyless entry transmitter in order to unlock the doors, the K9 Body Control Module (BCM) receives a door-unlock signal. The BCM must receive inputs from various systems that indicate that the ignition switch is OFF, the courtesy lamp switch is OFF, and all doors are closed before the BCM will activate the interior lamps. After all doors have been closed, the courtesy lamps will turn OFF immediately if the ignition switch is turned to the ON position, the door locks are LOCKED, or approximately 20 seconds after the last door closes. The BCM will turn off the courtesy lamps through the theater dimming feature. The BCM keeps the courtesy lamps on for 40 seconds after an alarm event is completed.

### Reading Lamps

When a reading lamp button is pressed, the switch contacts close providing a path to ground for the signal circuit from the A103 Roof Console. The roof console responds by applying battery voltage to the appropriate reading lamp control circuit illuminating the reading lamp. If the operator inadvertently leaves a reading lamp ON, the BCM will send a serial data message to turn all interior lighting off after 10 minutes has passed to prevent total battery discharge.

### Sunshade Mirror Lamp

The inadvertent power supply voltage circuit from the K9 Body Control Module (BCM) provides battery voltage to the passenger side sunshade mirror lamp. When the sunshade mirror cover is opened, a switch closes providing ground and the sunshade lamp illuminates. If the operator inadvertently leaves the sunshade mirror cover open with the lamp ON, the BCM will turn all interior lamps OFF after 10 minutes has passed to prevent total battery discharge.

### Interior Lamps Dimming

With the S30 Headlamp Switch in the PARK or HEAD position, the park lamp switch signal circuit provides an input to the K9 Body Control Module (BCM). The BCM responds by applying voltage to the backlight dimming control circuits illuminating all components with interior backlighting. All interior backlighting turns on at the dimming level set by the dimmer buttons within the headlamp switch. The headlamp switch is used to increase and decrease the brightness of the interior backlighting components. The BCM provides a signal circuit and a low reference circuit to the headlamp switch for backlight dimming. When a dimming button is pressed, the signal circuit becomes grounded through the appropriate resistor internal to the headlight switch and voltage from the BCM will decrease accordingly. The BCM interprets the signal and responds in two ways. The BCM applies a pulse width modulated (PWM) voltage through the LED dimming control circuits illuminating the interior backlighting to the requested level of brightness. The BCM also sends a serial data message to the appropriate control modules requesting all dimming components to be illuminated to the same level of brightness.

### Battery Rundown Protection/ Inadvertent Power

The K9 Body Control Module (BCM) inadvertent power supply voltage circuit provides battery voltage to all of the interior courtesy lamps. In the event that any of these lamps were to remain illuminated for a period of more than 10 minutes with the ignition switch in the OFF position, the BCM will deactivate the inadvertent power supply voltage circuit to prevent total battery discharge. If the ignition switch is turned to any position other than OFF, or if a lamp switch is activated during this 10 minute period, the timer resets for another 10 minutes.

# Mirrors

## Schematic and Routing Diagrams

Inside Rearview Mirror Schematics (Inside Rearview Mirror (DD8 / DRZ))

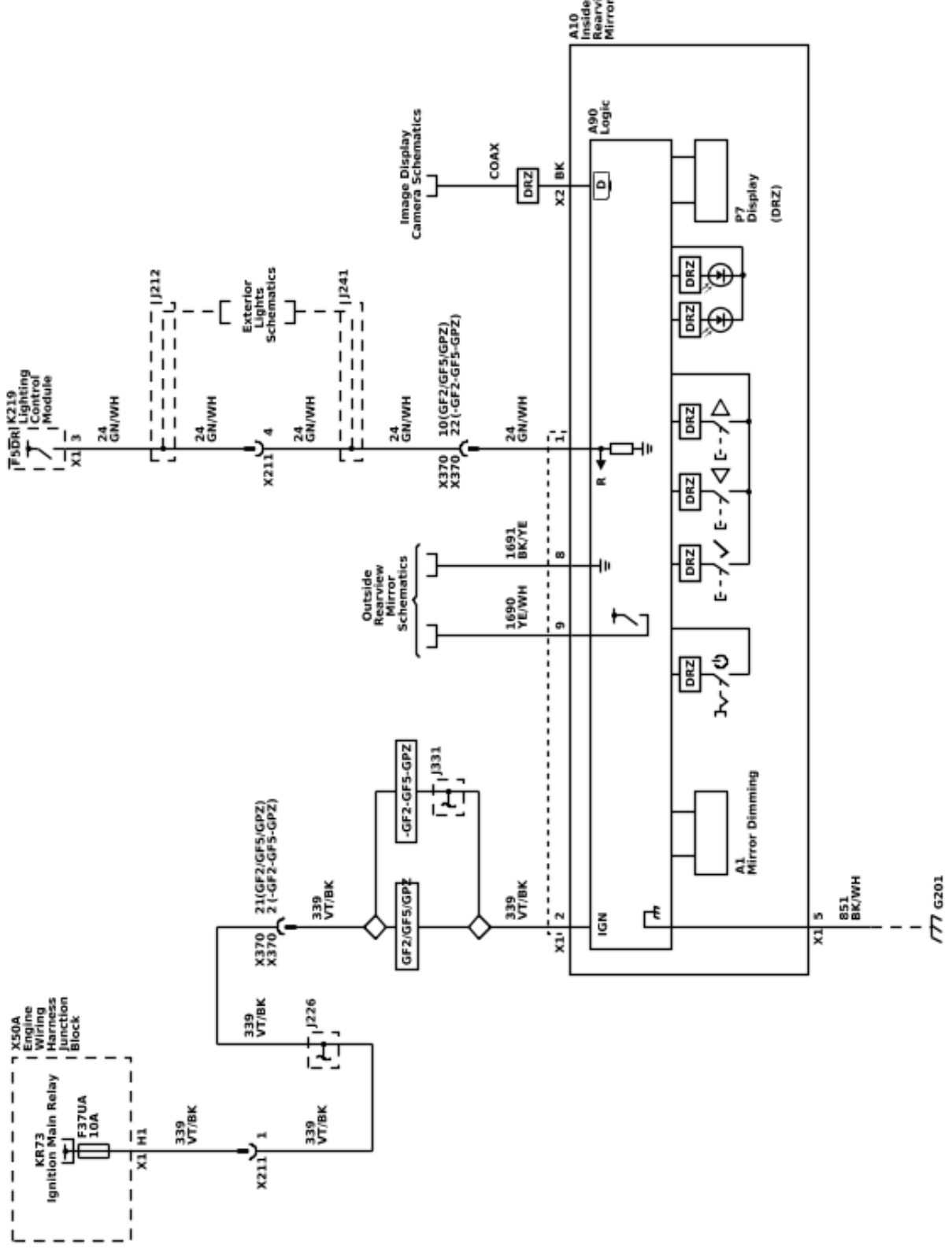



Outside Rearview Mirror Schematics (Driver Controls, Position, and Folding)

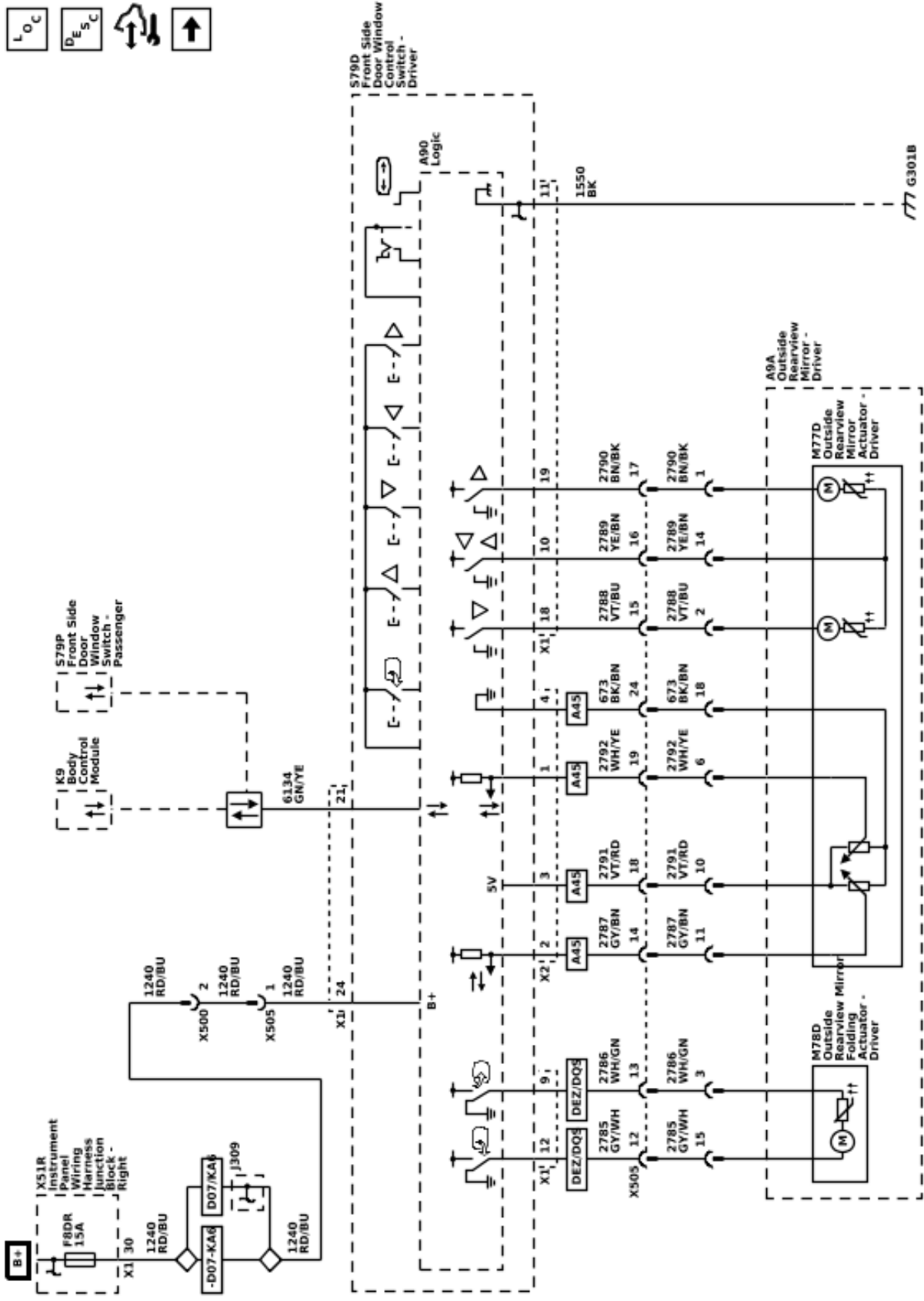
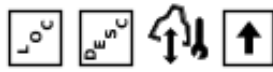

6278777



Outside Rearview Mirror Schematics (Dimming and Heating (DEZ))

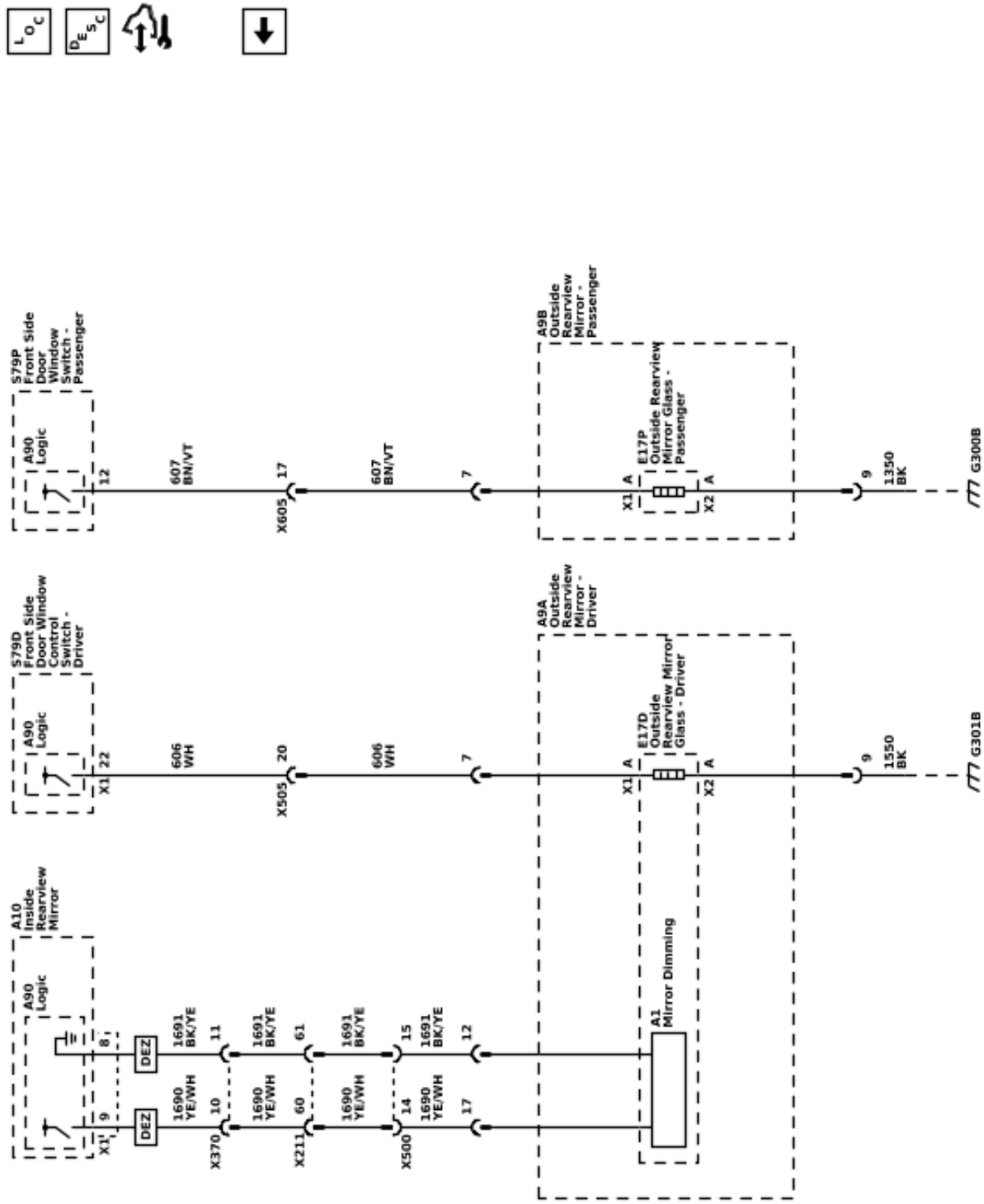

LOC

DES





## Repair Instructions

### Inside Rearview Mirror Replacement

**Warning:** Refer to Glass and Sheet Metal Handling Warning.

#### Removal Procedure

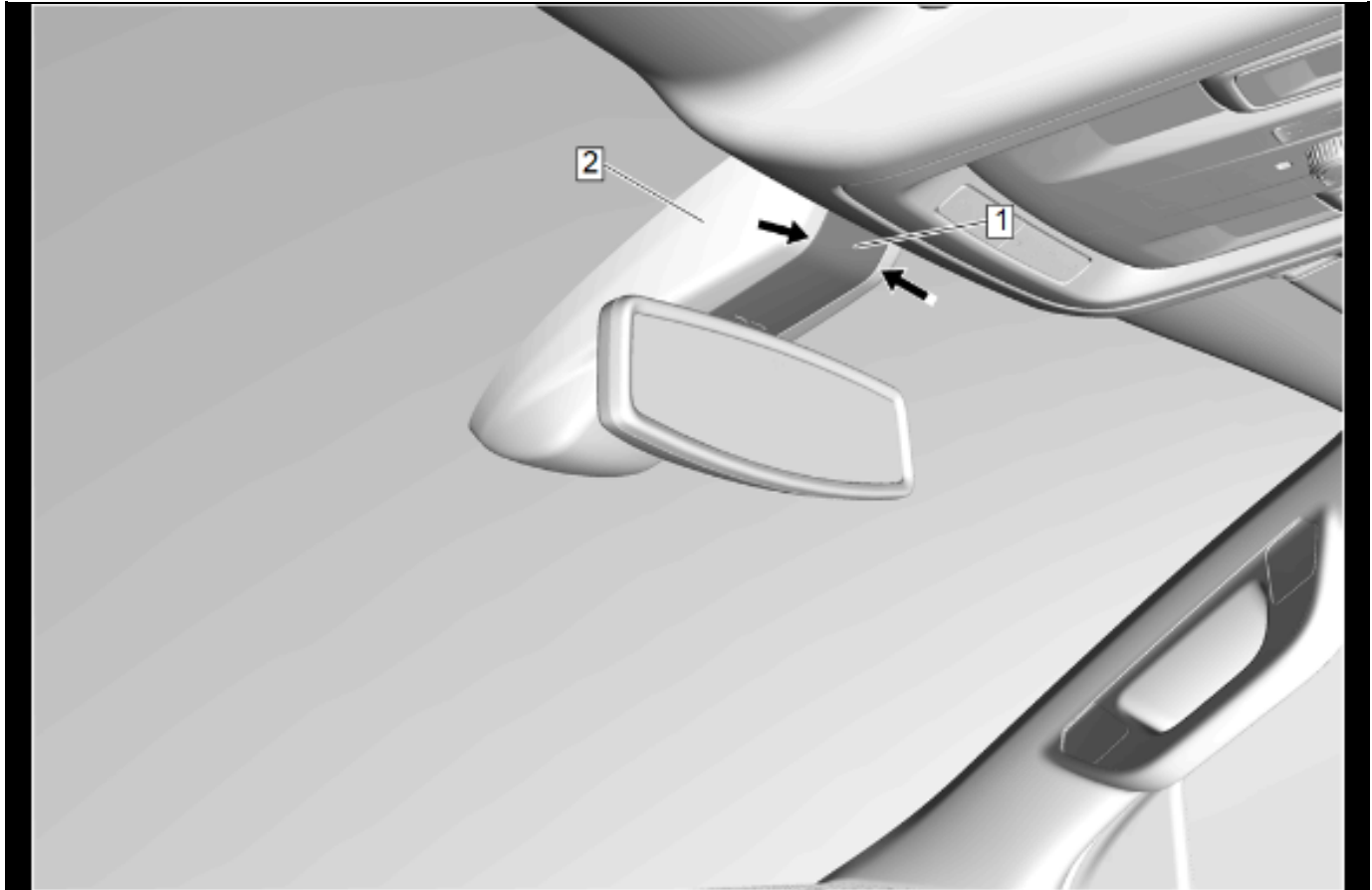

5579672

**Warning:** While operating, electrical control modules can produce heat and become hotter than their surroundings. To prevent burns allow sufficient time for the module to cool before removal.

1. Insert a suitable flat-bladed plastic trim tool between the windshield multifunction sensor mount bracket cover insert (1) and windshield multifunction sensor mount bracket cover (2).
2. Separate the windshield multifunction sensor mount bracket cover insert (1) from the windshield multifunction sensor mount bracket cover (2).

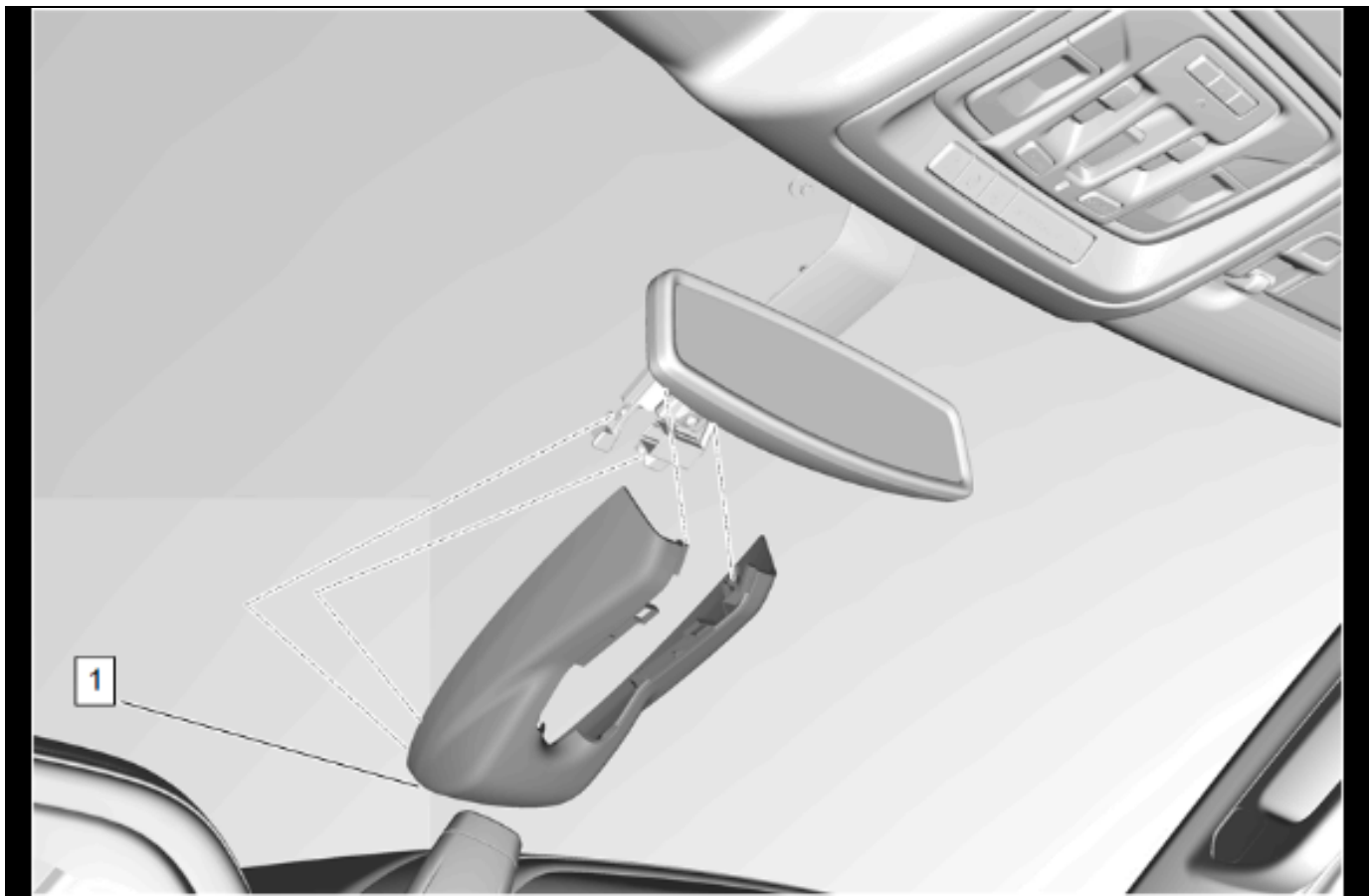

5641084

3. Using a suitable plastic trim tool, carefully pry downward on the windshield multifunction sensor mount bracket cover (1) to release it from the windshield.

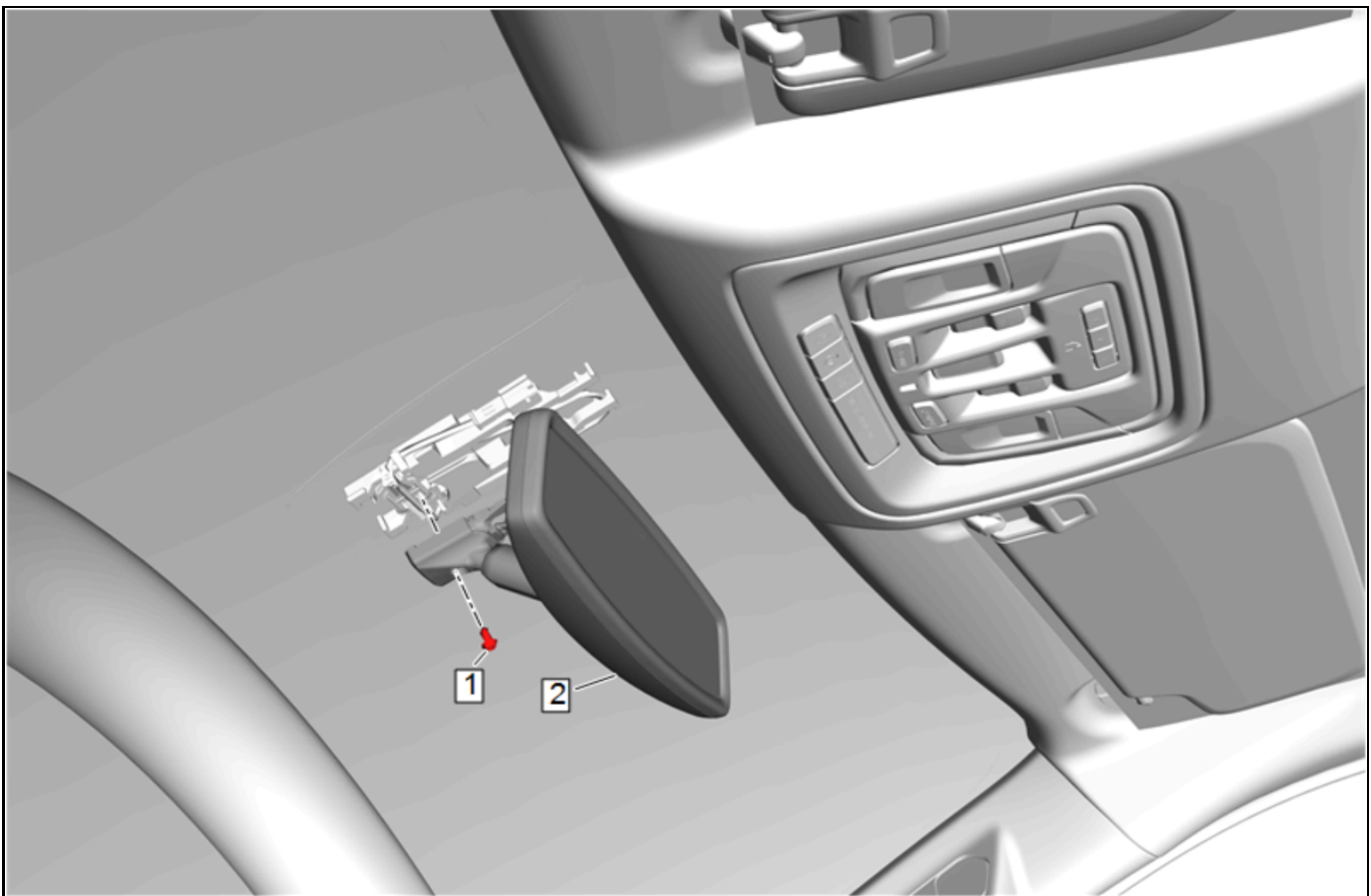

5044157

4. { If equipped } Disconnect all electrical connectors.
5. Inside Rearview Mirror Bolt (1) » Loosen  
**Note:** Slide the inside rearview mirror off the mirror mount.
6. Inside Rearview Mirror (2) » Remove

## Installation Procedure

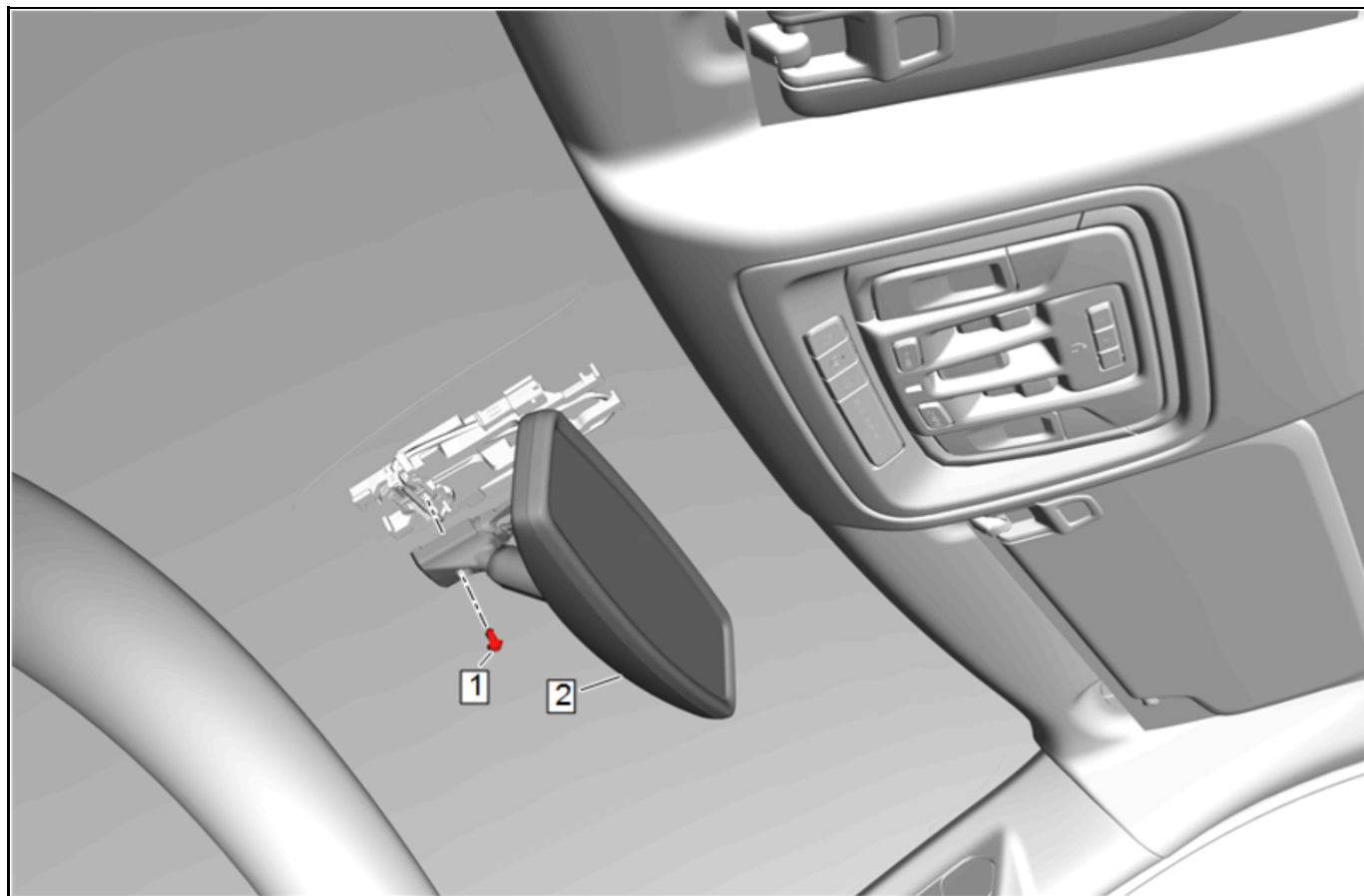

5044157

**Note:** Slide the inside rearview mirror onto the mirror mount.

1. Inside Rearview Mirror (2) » Install

**Caution:** Refer to Fastener Caution.

2. Inside Rearview Mirror Bolt (1) » Tighten — Fastener Specifications
3. { If equipped } Connect all electrical connectors.

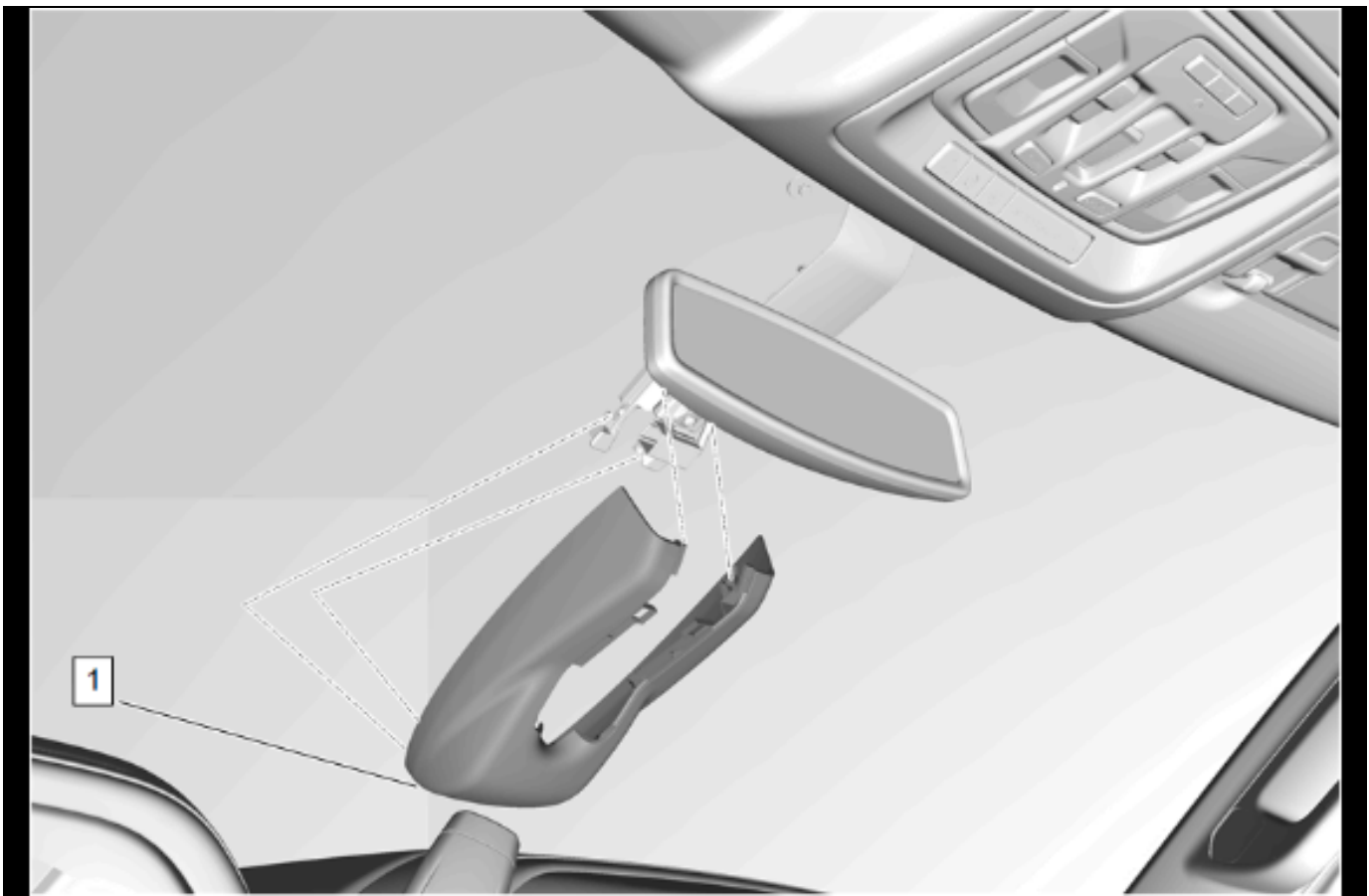

5641084

4. Install the windshield multifunction sensor mount bracket cover (1) ensuring the retaining tabs are fully seated.

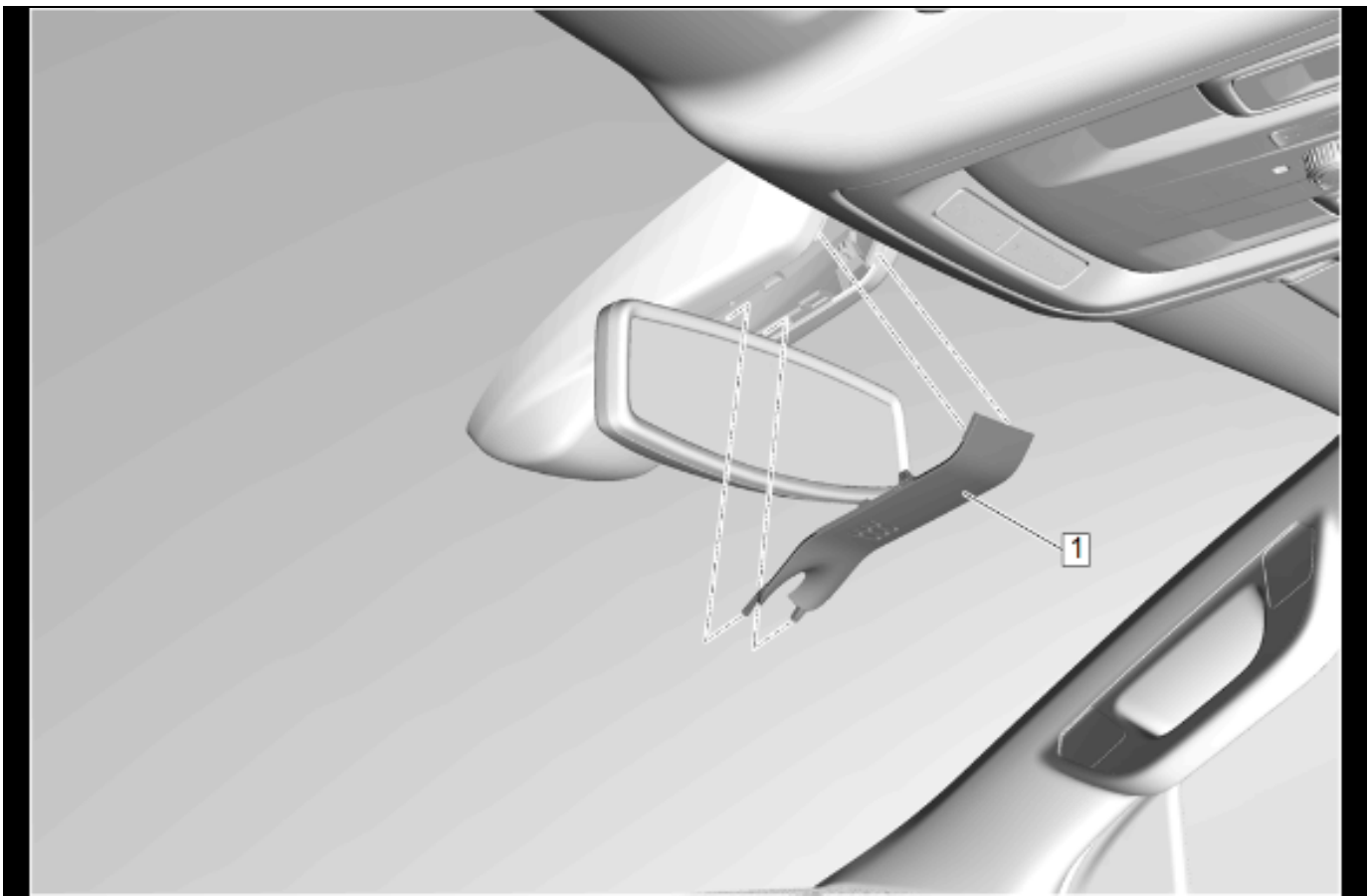

5579675

5. Windshield Multifunction Sensor Mount Bracket Cover Insert (1) » Install

## Description and Operation Automatic Day-Night Mirror Description and Operation

### Inside Rearview Mirror with the Automatic Day-Night Feature System Operation

The inside rearview mirror uses 2 photocell sensors. One sensor is the headlight sensor, located on the face side of the mirror. The headlight sensor is used to determine light conditions present at the mirror face. The other sensor is the ambient light sensor, located on the rear of the mirror or windshield side. The ambient light sensor is used to determine the exterior light conditions. With a low exterior light condition detected, and a high light condition from behind the car, at the headlight sensor, the inside rearview mirror will automatically darken the face of the mirror.

In the daytime, the mirror is in a normal state because of the high exterior light condition that is indicated by the ambient light sensor. With the gear selector lever in the REVERSE position and the Ignition ON/Vehicle in Service Mode, backup lamp supply voltage is supplied as an input to the inside rearview mirror. The mirror monitors this input to disable the automatic day-night feature. This allows the driver to see objects in the mirror clearly when backing up, even during the night.

### Driver Outside Rearview Mirror with Automatic Day-Night System Operation (If Equipped)

The automatic day-night feature of the driver outside rearview mirror is controlled by the inside rearview mirror. The inside rearview mirror supplies control and low reference to the driver outside rearview mirror. At night, with the automatic day-night feature enabled, the driver outside rearview mirror will automatically darken with the inside rearview mirror to reduce glare from headlamps behind the vehicle.

### Inside Rearview Camera Full Display Mirror System Operation

The inside rearview camera full display mirror is connected to the outside rearview camera via a shielded coaxial cable. When the tab under the inside rearview mirror is pulled rearward, a view of the area behind the vehicle displays on the mirror. Adjust the rearview mirror for a clear view of the area behind the vehicle before turning on full display mirror. Use the button on the back of the mirror to adjust the brightness of the display. Make sure the light sensor is not covered when adjusting the brightness.

The inside rearview camera full display mirror may not work properly or display a clear image if:

- It is dark.
- The sun or the beam of headlamps are shining directly into the camera lens.
- Ice, snow, mud, or anything else builds up on the camera lens. Clean the lens, rinse it with water, and wipe it with a soft cloth.

When the mirror detects that the camera is not sending a valid video signal, it “blue screens” with a “no video” decal for 3 seconds, then reverts back to the mirror. Meanwhile, if a blue screen keeps on displaying instead of the camera view, take the vehicle to your dealer for service.

### Rearview Camera Full Display Mirror Block Diagram

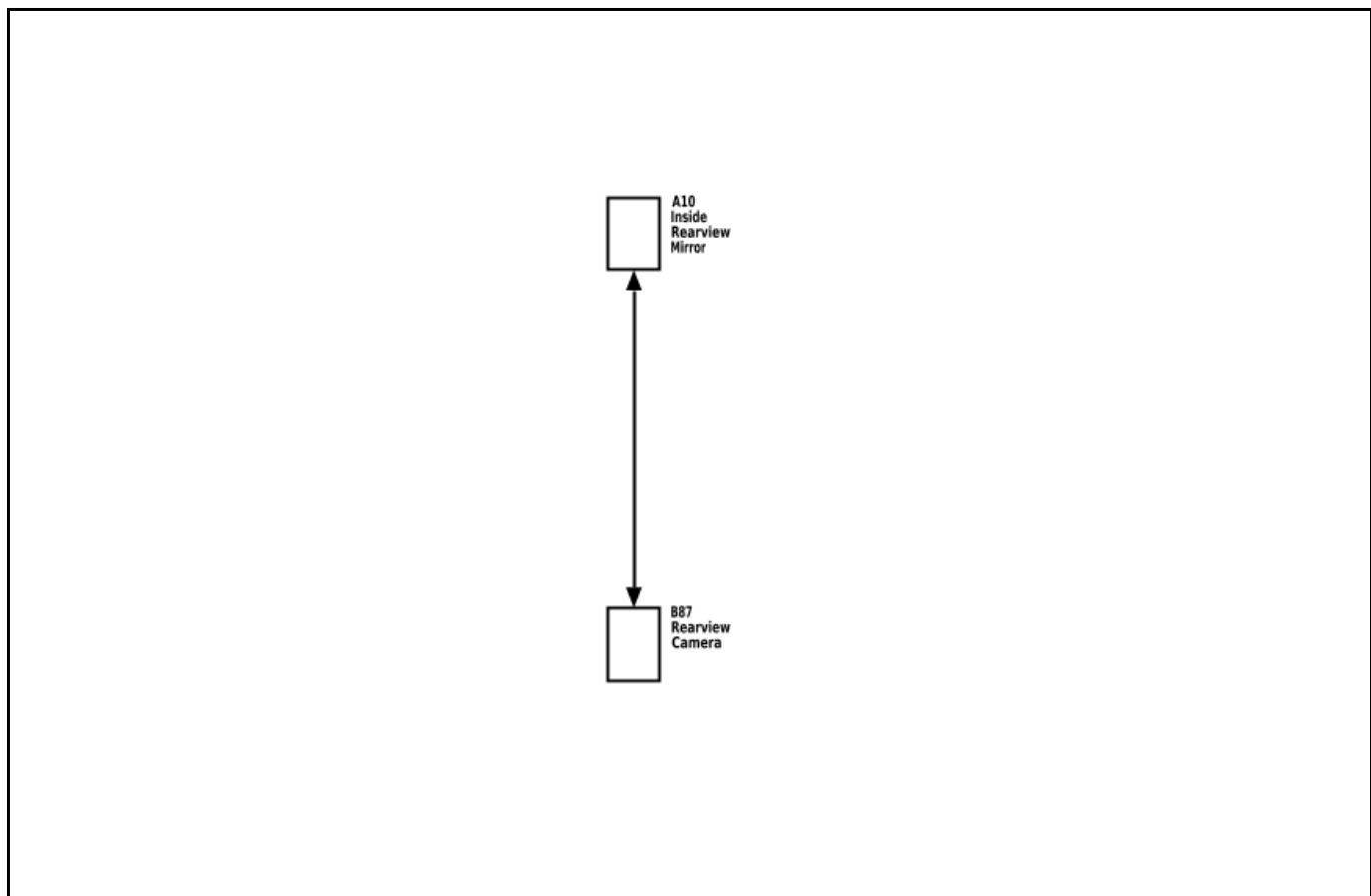

4433072

## Outside Mirror Description and Operation

### Power Mirror System Components

The power mirror system consists of the following components:

- Body Control Module
- Driver Seat Adjuster Memory Module
- Outside Mirror Switch
- Passenger Window Switch
- Left Outside Rearview Mirror
- Right Outside Rearview Mirror

### Power Mirror System Controls

The outside rearview mirror switch is part of the S79D Driver Front Side Door Window Control Switch and uses serial data to control the passenger mirror through the S79P Passenger Front Side Door Window Control Switch. Each S79 Side Door Window Control Switch has its own 12V, ground and data communications circuit along with mirror directional control and mirror fold circuits.

### Driver Mirror Controls

The S79D Driver Front Side Door Window Control Switch has internal connections for the driver mirror. When the mirror position switch is active the driver mirror is commanded to move through bi-directional

motor control circuits. The motor control circuits are floating while in an inactive state and the switches will apply power and ground to the control circuits as necessary to move the mirror in the commanded direction.

### **Passenger Mirror Controls**

The S79D Driver Front Side Door Window Control Switch uses serial data circuits to communicate the active states for the passenger mirror switch to the S79P Passenger Front Side Door Window Control Switch. The S79P Passenger Front Side Door Window Control Switch has internal connections for the passenger mirror. When the mirror position switch is active the passenger mirror is commanded to move through bi-directional motor control circuits. The motor control circuits are floating while in an inactive state and the switches will apply power and ground to the control circuits as necessary to move the mirror in the commanded direction.

### **Mirror Position**

Mirror position is determined by both horizontal and vertical position sensors in each of the power mirrors. Each S79 Front Side Door Window Control Switch supplies a 5 V reference, low reference, and horizontal and vertical position signal circuits to these sensors. The signal circuits are referenced from 5 V by the S79 Front Side Door Window Control Switch and the signal circuit voltage levels represent the mirror positions. The mirror positions are stored in each S79 Front Side Door Window Control Switch for memory mirror operation. When the memory seat module receives a memory recall command, the memory seat control module will send the go to position to the S79 Front Side Door Window Control Switch. The S79 Front Side Door Window Control Switches will then drive the appropriate mirror motors to the commanded position sensor settings.

### **Mirror Select**

The S79D Driver Front Side Door Window Control Switch has internal connections for the mirror select switch. When the mirror select switch is active the S79 Front Side Door Window Control Switch will either control the driver mirror or send a serial data message to control the passenger mirror.

### **Folding Mirrors**

The S79D Driver Front Side Door Window Control Switch sends the mirror fold/unfold inputs to the K9 Body Control Module (BCM) through serial data. When the BCM receives a fold/unfold signal it will send a fold/unfold command to the S79 Driver Front Side Door Window Control Switch which will send a serial data message to the S79P Passenger Front Side Door Window Control Switch. The outside mirrors will fold or unfold depending on their current state. The BCM will also send a serial data message to unfold the mirrors when the vehicle reaches 20 km/h (12 mph). The S79 Front Side Door Window Control Switches control the fold/unfold motors through bi-directional control circuits

### **Heated Mirrors**

The heated mirrors are controlled through each S79 Front Side Door Window Control Switch. When the vehicle is running and the HVAC control module receives a rear window defog request from the radio/HVAC controls, the HVAC control module will send a serial data message to the S79D Driver Front Side Door Window Control Switch and S79P Passenger Front Side Door Window Control Switch. Each S79 Front Side Door Window Control Switch provide B + voltage to the driver and passenger outside rearview mirror heating elements.



# Trailer Systems

## Schematic and Routing Diagrams

Trailing Systems Schematics (Trailer Lighting Control Module (UET))

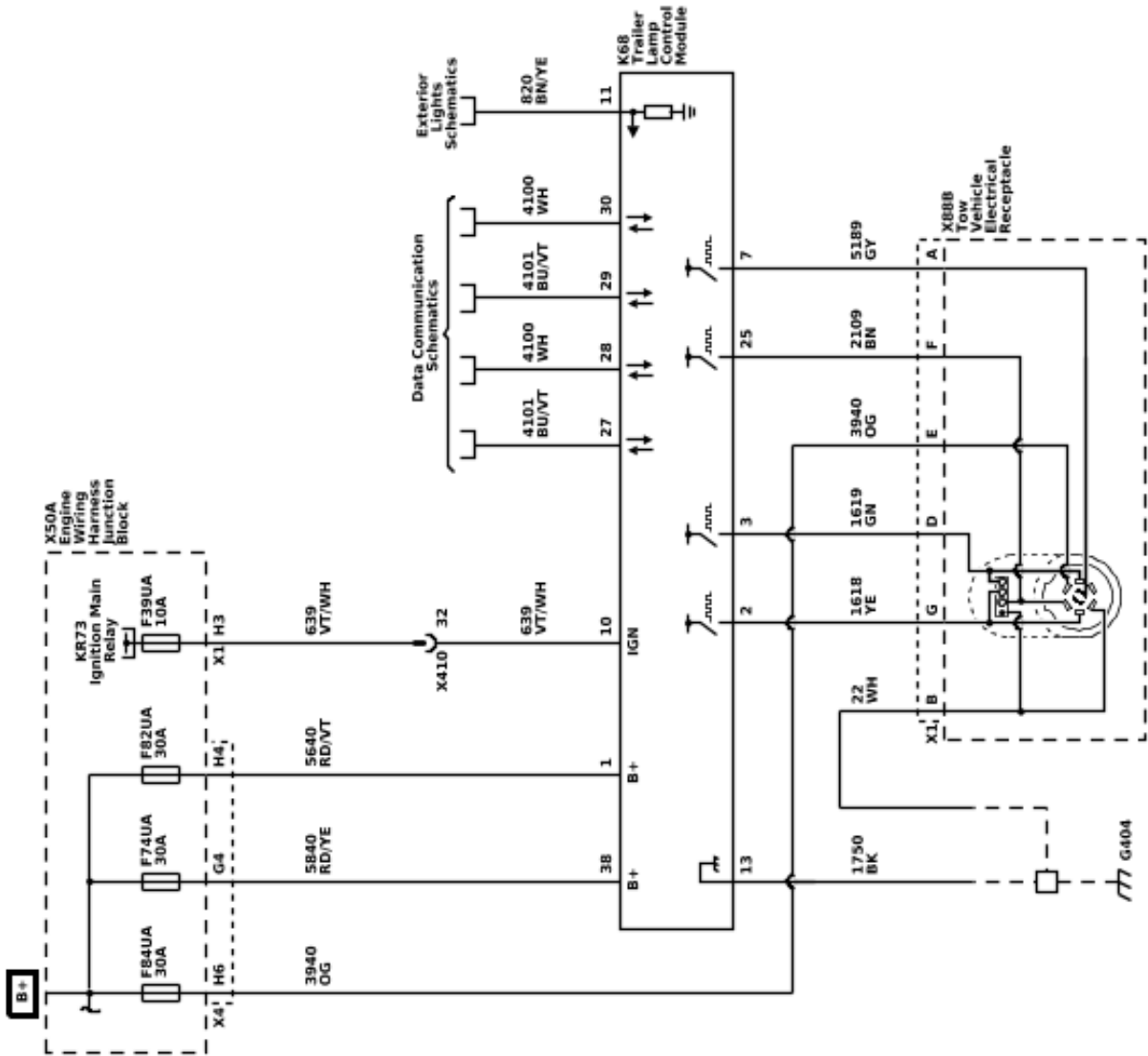
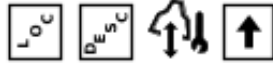

Trailer Systems Schematics (Trailer Connector Pins: A, B, D, E, F, G (Z82 & - UET))

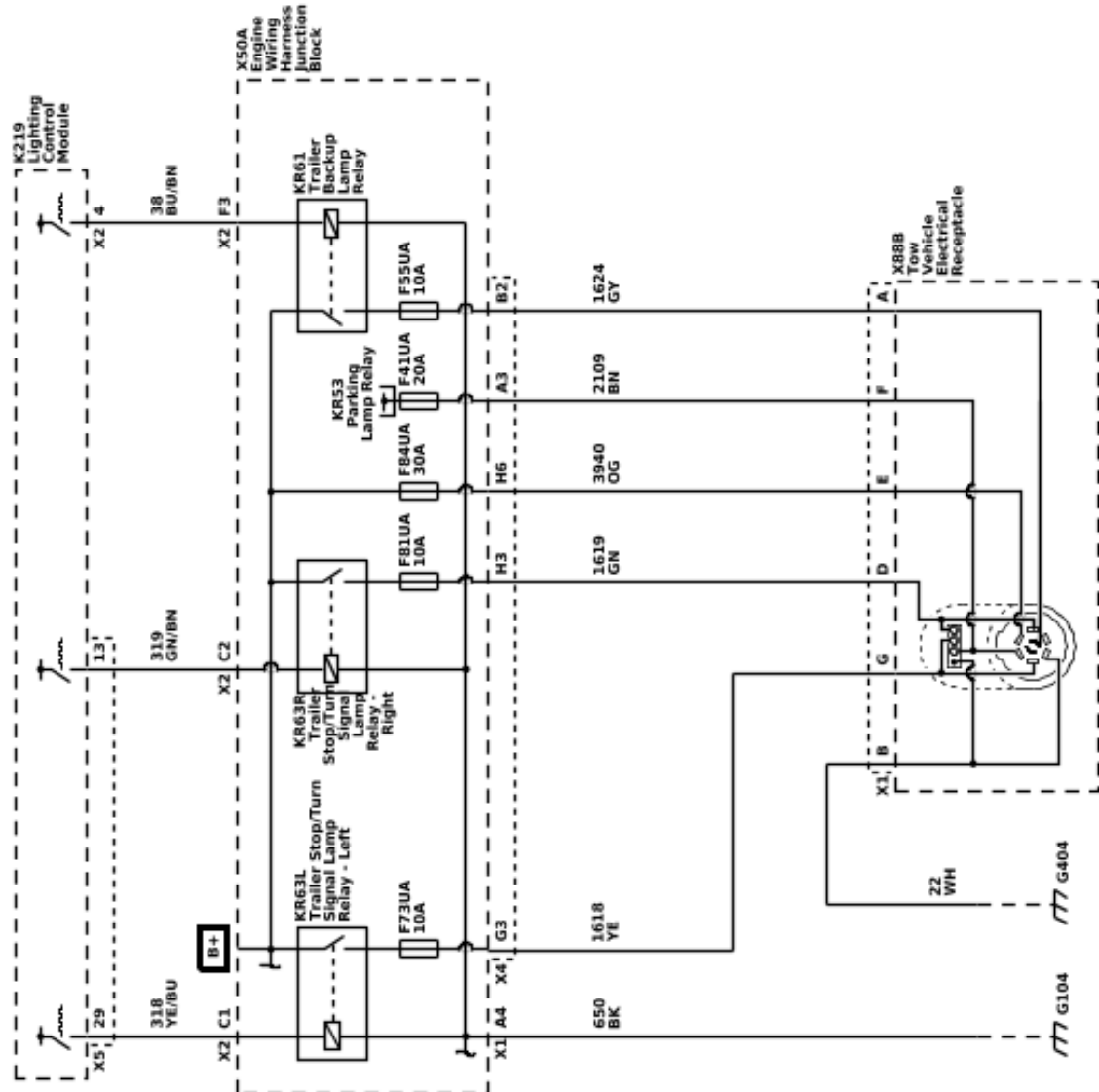
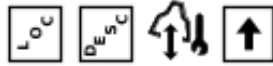

Trailing Systems Schematics (Trailer Brake Provisions (Z82 & - JL1))

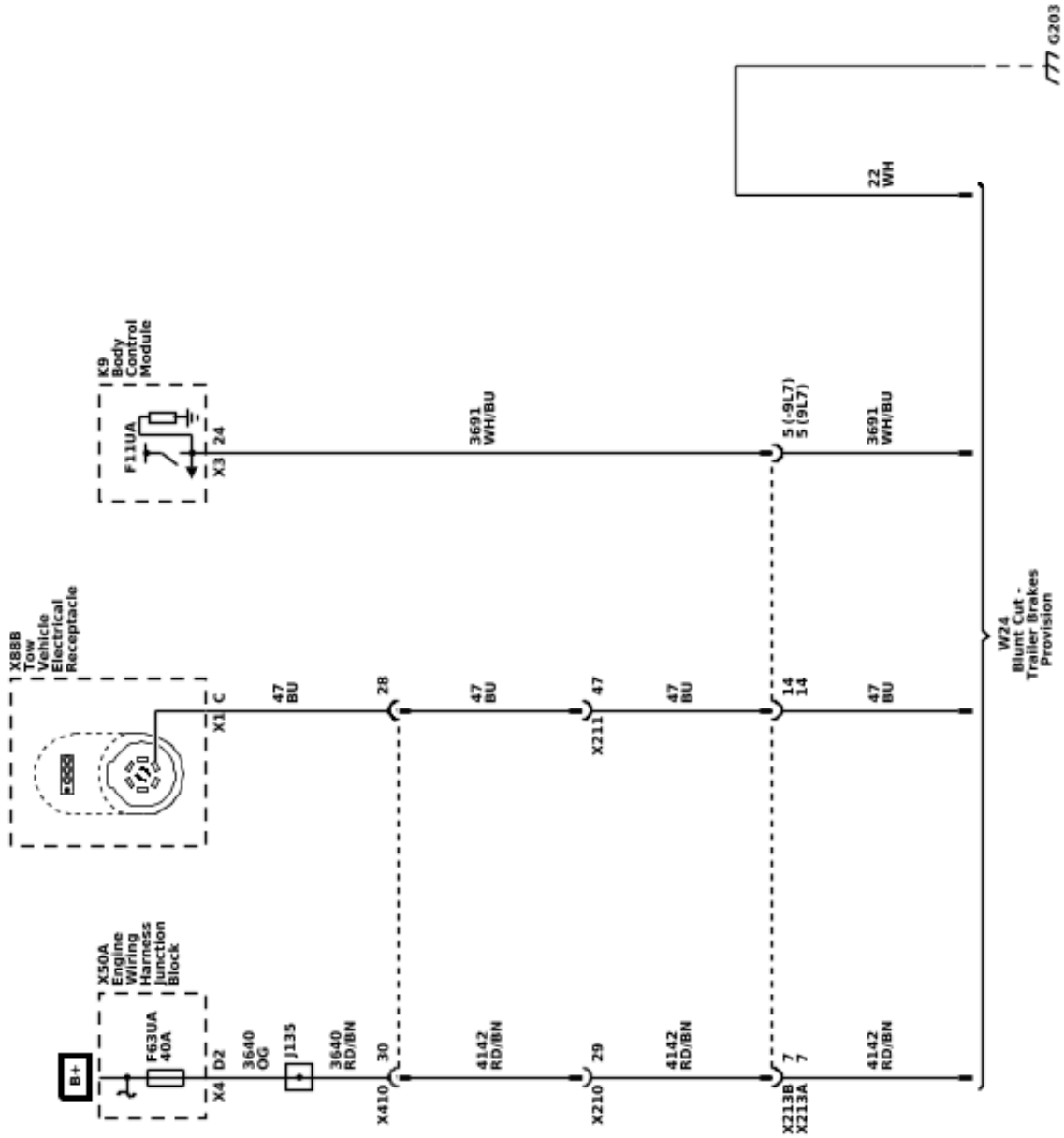

Trailing Systems Schematics (Trailer Brake (JL1))

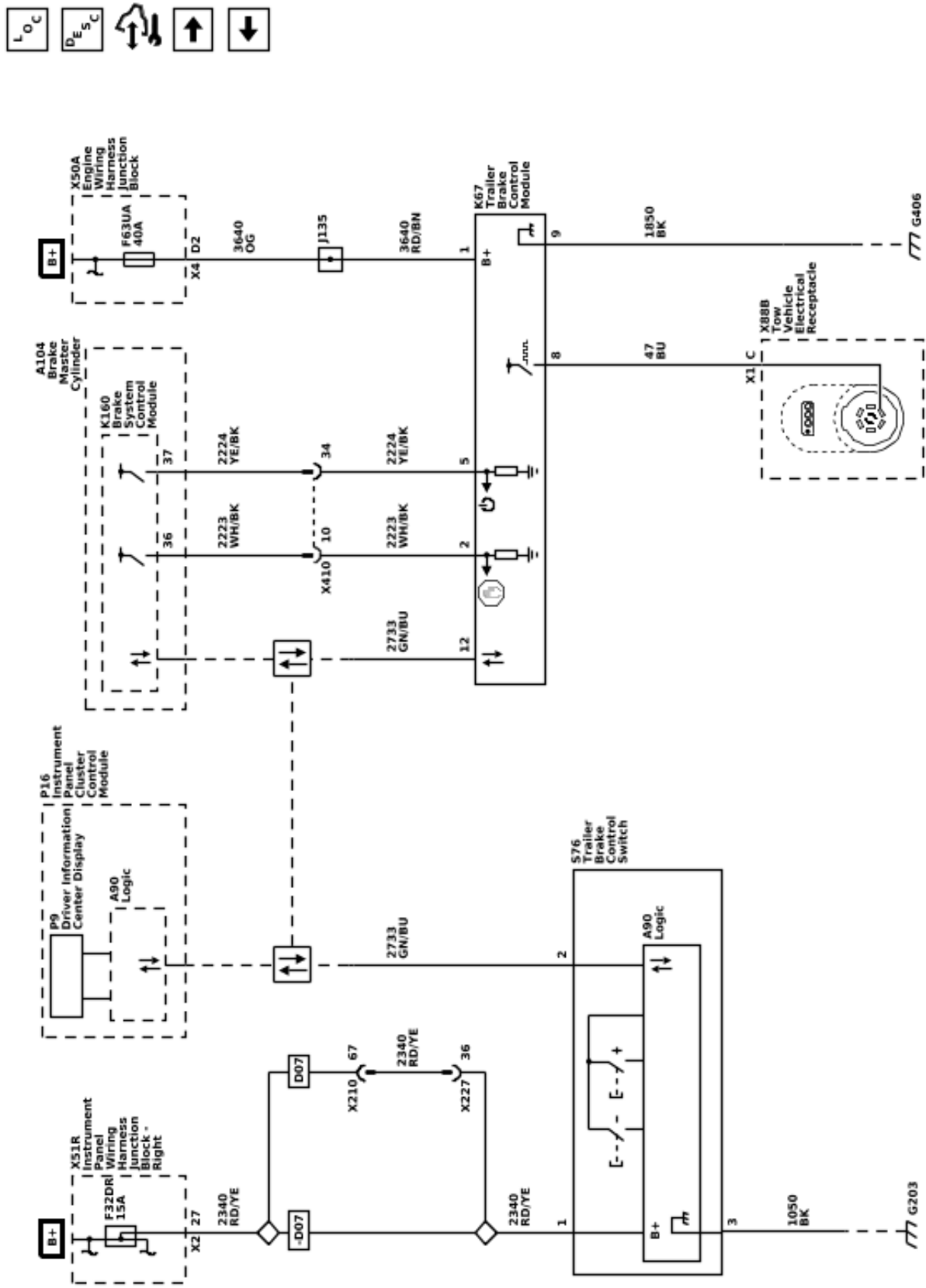

Trailing Systems Schematics (Trailer Tire Pressure (UET))

LOC

DES

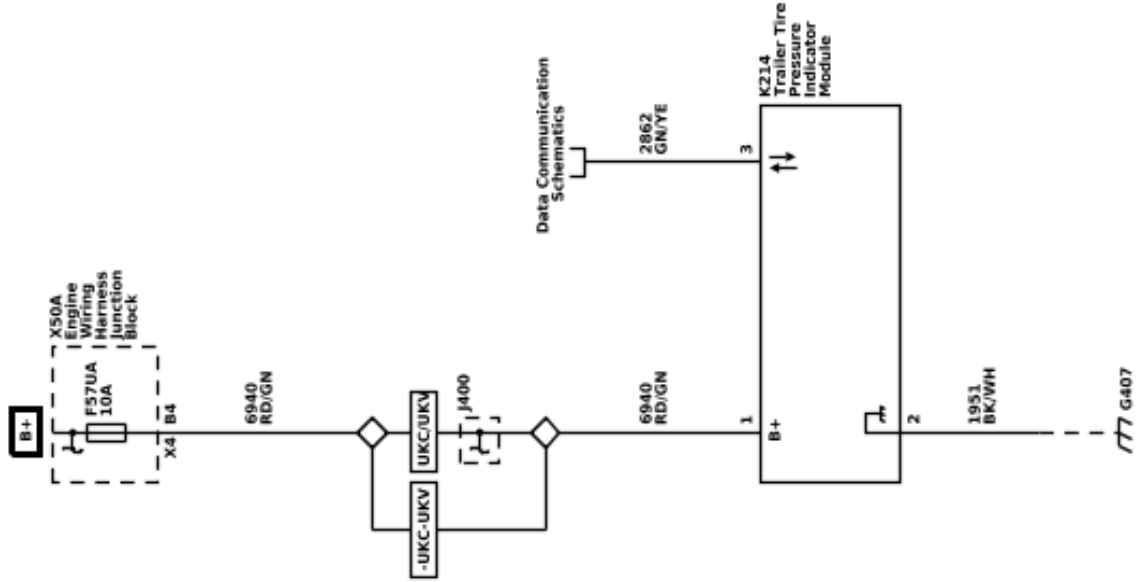

## Description and Operation

### Trailer Description and Operation

#### Trailer System Overview

Begin the trailering system diagnosis with Diagnostic System Check - Trailering. The Diagnostic System Check - Trailering will provide a complete strategy to locate and repair a vehicle trailering electrical fault. Not following this strategy may cause additional diagnostic time and/or misdiagnosis.

The trailering system consists of the following:

- Trailer Lighting, refer to Trailer Lamps Malfunction for additional diagnostic information.
- {JL1} Trailer Brakes, refer to Trailer Brake Malfunction for additional diagnostic information.
- Trailer Battery Charging System, refer to Trailer Battery Charging Malfunction for additional diagnostic information.
- Trailer Detection, refer to Trailer Detection Malfunction for additional diagnostic information.
- Trailer Tire Pressure Monitoring System, refer to Trailer Tire Pressure Monitoring Malfunction for additional diagnostic information.
- Trailer Theft Detection.

#### 7-Terminal Tow Vehicle Electrical Receptacle Pinout

- Terminal A – Trailer Backup Lamp Control
- Terminal B – Ground
- Terminal C – Trailer Brake Control
- Terminal D – Right Trailer Stop/Turn Signal Lamp Control
- Terminal E – B+
- Terminal F – Trailer Park Lamp Control
- Terminal G – Left Trailer Stop/Turn Signal Lamp Control

#### Connecting Aftermarket Accessories

- Some aftermarket accessories that connect to the X88B Tow Vehicle Electrical Receptacle will be recognized by the vehicle as a trailer connected, even if the accessory is not a trailer. As a result, side blind zone detection, rear park assist, and/or rear cross traffic alert will be turned off anytime the vehicle detects a trailer/accessory is connected.
- Vehicles equipped with U1D/UET have trailer theft detection that constantly monitors trailer connected status when enabled. This is done by randomly pulsing the lighting circuits of the trailer when the vehicle is parked. As a result, some aftermarket accessories may be turned ON/OFF when connected to the vehicle with theft detection enabled.
- Vehicles equipped with U1D/UET use pulse width modulation voltage (PWM) for trailer lighting functions. Some aftermarket accessories are incompatible with PWM and may not function correctly when connected to the trailer lighting circuits of the vehicle.

#### Trailer Battery Charging System

Trailer battery charging is accomplished through constant battery voltage from the X50A Engine Wiring Harness Junction Block to the X88B Tow Vehicle Electrical Receptacle. Battery voltage is supplied to terminal E at the X88B Tow Vehicle Electrical Receptacle at all times. If equipped, the trailer battery will constantly be charged by the vehicle's electrical system anytime the trailer is connected. Some trailers require the B+ circuit to the X88B Tow Vehicle Electrical Receptacle for the trailer brakes to function.

#### Trailer Lighting and Detection With U1D/UET

##### Note:

- Some trailers utilize a trailer mounted control module to operate some or all of the trailer lights. These trailers may use the B+ circuit from the trailer connector to power the trailer lighting circuits. These trailers may not always be detected by the Trailer Lighting Control Module and may set faults.
- When a trailer is detected on a vehicle equipped with side blind zone detection, rear park assist, and/or rear cross traffic alert, the vehicle will automatically turn these features off. These features are turned off to prevent false detections due to the trailer obstructing the view of the sensors.
- Vehicles equipped with IOR/1FL do not come equipped with the trailering APP however may still be equipped with a K68 trailer Lamp Control Module.

The K68 Trailer Lamp Control Module is responsible for controlling the trailer lighting on vehicles with U1D/UET. The combined trailer stop/turn signal lamps of the trailer must draw at least 55mA of total current to be detected as a trailer or the Trailer Lamp Control Module will not control the lighting circuits. The Trailer Lamp Control Module receives serial data messages from the K9 Body Control Module (BCM) indicating what lamps have been activated on the vehicle. The Trailer Lamp Control Module responds by applying pulse width modulated voltage (PWM) to the appropriate control circuits for the requested lamps illuminating the lamps on the attached trailer. The Trailer Lamp Control Module constantly monitors for trailer connection status, trailer lighting faults, and trailer theft deterrent purposes. This is accomplished through the lighting circuits of the trailer to determine if a trailer is connected. When a trailer is connected, the Trailer Lamp Control Module senses the trailer connection and alerts the driver by requesting a trailer profile setup through the Trailering App, which is displayed on the infotainment screen. If a trailer is disconnected with the ignition ON, the vehicle will display multiple trailer lighting messages until a trailer is reconnected or the message is dismissed by the user. With the key OFF, the Trailer Lamp Control Module will periodically pulse the lighting circuits of the trailer to verify it is still connected. The lights on the trailer may flash at different intervals with the key OFF depending on which type of lights the trailer is built with. If a trailer is

## 2-64 Trailing Systems

disconnected with the key ON, the vehicle will display a trailer disconnected message until a trailer is reconnected or the ignition is cycled.

### Trailer Lighting Without U1D/UET

The K219 Lighting Control Module is responsible for controlling the trailer lighting on vehicles without U1D/UET. The lighting control module receives serial data messages from the K9 Body Control Module (BCM) indicating what lamps have been activated on the vehicle. The lighting control module responds by applying voltage to the appropriate relay control circuits for the requested lamps anytime the vehicle lamps are commanded ON. With the relay coil energized, the relay contacts close and allow voltage to flow through the relay illuminating the appropriate lamps on the attached trailer.

### Trailing Messages

The Infotainment Display may display one or more of the following messages to the user related to trailing:

#### Trailing Messages

Trailing Message	Description
Check Trailer Left Turn Signal Lamp	The K68 Trailer Lighting Control Module detects a fault on the left trailer stop/turn lamp control circuit
Check Trailer Right Turn Signal Lamp	The K68 Trailer Lighting Control Module detects a fault on the right trailer stop/turn lamp control circuit
Check Trailer Rear Lamp	The K68 Trailer Lighting Control Module detects a fault on the trailer park lamp control circuit.
Check Trailer Reversing Lamp	The K68 Trailer Lighting Control Module detects a fault on the trailer backup lamp control circuit.
Check Trailer Brake Lamps	The K68 Trailer Lighting Control Module detects a fault on the left and/or right trailer stop/turn lamp control circuits
{JL1} Check Trailer Wiring	The K67 Trailer Brake Control Module detects a fault on the trailer brake control circuit or the trailer was disconnected.
Lane Change Alert Off	Reminder to the user that lane change alerts are turned off anytime a trailer is detected.
Rear Cross Traffic Alert Off	Reminder to the user that rear cross traffic alerts are turned off anytime a trailer is detected.
Rear Park Assist Off	Reminder to the user that rear park assist is turned off anytime a trailer is detected.
Remember to turn On Tow/Haul Mode	Reminder to the user to turn ON Tow/Haul Mode when towing.
{JL1} Service Trailer Brake System	The K67 Trailer Brake Control Module detects a fault on the trailer brake control circuit.
Service Trailer Tire Monitor System	The K214 Trailer Tire Pressure Indicator Module detects one or more issues with the trailer tire pressure monitoring system.
Trailer Detected	The K68 Trailer Lighting Control Module detects a trailer has been connected to the X88B Tow Vehicle electrical Receptacle.
{JL1} Trailer Brakes Detected	The K67 Trailer Brake Control Module detects a trailer with trailer brakes has been connected to the X88B Tow Vehicle electrical Receptacle.
Trailer Disconnected Check Connection	The K68 Trailer Lighting Control Module detects a trailer has been disconnected from the X88B Tow Vehicle electrical Receptacle.
Trailer Tire Pressure High	The K214 Trailer Tire Pressure Indicator Module detects one or more of the trailer tire pressures is high.
Trailer Tire Pressure Low	The K214 Trailer Tire Pressure Indicator Module detects one or more of the trailer tire pressures is low.
Trailer Tire Sensor Fault	The K214 Trailer Tire Pressure Indicator Module detects one or more of the trailer tire pressure sensors has a fault.



## Trailer Messages (cont'd)

Trailer Message	Description
Trailer Tire Temperature High	The K214 Trailer Tire Pressure Indicator Module detects one or more of the trailer tire temperatures is too high.

## Trailer Theft Detection (With U1D/ UET Only)

Trailer theft monitoring can be turned ON and OFF through the vehicle Trailer App. When enabled, any time the trailer theft deterrent system is armed, the trailer lighting circuits are constantly monitored to determine if a trailer is connected for trailer theft deterrent purposes. With the key OFF, the K68 Trailer Lamp Control Module will randomly pulse the lighting circuits of the trailer to verify it is still connected by monitoring the voltage drop of the circuit. Depending on the configuration of the trailer lights, the trailer lights may randomly flash as part of the trailer theft deterrent function. These flashes correspond to when the K68 Trailer Lamp Control Module pulses the lighting circuits to ensure the trailer is still connected and is considered normal. If the trailer is disconnected while the trailer theft deterrent system is armed, the vehicle will flash the exterior lights and cycle the horn to alert of a trailer theft event. Refer to Theft Systems Description and Operation for more information on the content theft deterrent system.

## Trailer Brakes (JL1)

The vehicle is equipped with the following trailer braking components:

- K160 Brake System Control Module
- K67 Trailer Brake Control Module
- S76 Trailer Brake Control Switch
- Trailer Brake Driver Information Center Display

### Trailer Brake Circuits

- Circuit 2223 is the trailer brake apply signal circuit. The K160 Brake System Control Module receives vehicle braking force data and/or data from the application of the manual trailer brake slide lever. The brake system control module responds by applying the appropriate amount of pulse width modulated (PWM) voltage based on the amount of trailer brake application desired. The K67 Trailer Brake Control Module responds to the signal circuit by applying the appropriate amount of PWM voltage to the trailer auxiliary control circuit 47.
- Circuit 2224 is the trailer brake enable signal circuit. The K160 Brake System Control Module applies voltage to the enable circuit anytime a LIN data communication fault is not present, a trailer is connected, and the vehicle brakes are being applied. The enable circuit must have voltage applied to it before the K67 Trailer Brake Control Module applies the appropriate amount of pulse width modulated (PWM) voltage to the trailer auxiliary control circuit 47.
- Circuit 2733 is the brake system control module LIN bus 2 circuit. The K160 Brake System Control Module, K67 Trailer Brake Control Module, and the S76 Trailer Brake Control Switch all communicate through the brake system control

module LIN bus 2 circuit. If the LIN bus has a fault on the circuit, trailer braking will be disabled until the fault is repaired.

- Circuit 47 is the trailer auxiliary control circuit. The K67 Trailer Brake Control Module responds to signal circuit 2223 and enable circuit 2224 by applying the appropriate amount of PWM voltage to the trailer auxiliary control circuit. A properly functioning trailer will apply the appropriate amount of braking force to the brakes of the trailer.

**The Trailer Brake Control System is compatible with two types of Trailer Brake Systems as listed below:**

1. **Electric Brakes** A controlled electrical output signal energizes an electric-magnet/lever arm assembly that directly actuates the brake mechanism. The GDS name for this system is "Electromagnetic Brakes".
2. **Electric Over Hydraulic Brakes** A controlled electrical output signal energizes a remote, trailer mounted hydraulic pump to build brake pressure in a closed hydraulic system on the trailer. The hydraulic fluid pressure actuates the brake mechanism. The GDS name for this system is "Electrohydraulic Brakes".

### Trailer Brake Output Versus Trailer Brake Type

- The trailer brake system characterizes the trailer brakes as either Electric Brake or Electric Over Hydraulic Brake automatically. This characterization may be affected by the number, type, and age of the trailer brake magnets, as well as any other devices installed on the trailer brakes (i.e. adapters for Electric Over Hydraulic brake functionality).
- The trailer brake system is fully operational with either characterization.
- Sliding the manual trailer brake apply lever will produce output at zero speed for either characterization.

The user gain allows the driver to adjust the amount of trailer brake output to match the trailer load and road surface. The controller determines the desired trailer brake output and provides a control signal to the K67 Trailer Brake Control Module (TBPM). The K67 Trailer Brake Control Module amplifies the signal and provides the output required to activate the Electric or Electric Over Hydraulic trailer brakes.

The trailer brake control can support up to a maximum of four axles with electric trailer brakes (8 brake magnets).

Connecting a trailer that is not compatible with the trailer brake system may result in reduced or complete loss of trailer braking. There may be an increase in stopping distance or trailer instability which could result in personal injury or damage to the vehicle, trailer or other property. An aftermarket controller may be available for use with incompatible trailer brake systems.

To determine the type of brakes on your trailer and the availability of controllers, check with your trailer manufacturer or dealer. Do not power up an aftermarket controller with the factory brake controller at the same time.

### Trailer Brake Control Panel

The S76 Trailer Brake Control Switch contains the trailer gain and manual apply switches. It is located in the vehicle center stack. Refer to the owner's manual for more information on the location. The control panel and switches allows you to adjust the amount of output, referred to as trailer gain, available to the Electric or Electric Over Hydraulic brakes. It also allows you to manually apply the trailer brakes. The trailer brake control switch is used along with the trailer brake display page on the driver information center to adjust and display power output to the trailer brakes.

### Manual Trailer Brake Apply

The manual trailer brake apply lever is located on the S76 Trailer Brake Control Switch and is used to apply the trailer's Electric or Electric Over Hydraulic brakes independent of the vehicle's brakes. This lever is used in the trailer gain adjustment procedure to properly adjust the power output to the trailer brakes.

Sliding the lever will apply only the trailer brakes. The power output to the trailer is indicated in the trailer brake display page in the Driver Information Center (DIC). If the vehicle's service brakes are applied while using the manual trailer brake apply lever, the trailer brake control output power will be the greater of the two.

The trailer and the vehicle's brake lamps will come on when either the vehicle's braking or manual trailer brakes are applied.

### Trailer Brake Gain Adjustment

Trailer gain should be set for a specific trailering condition and must be adjusted any time vehicle loading, trailer loading or road surface conditions change. It is important to re-adjust trailer gain any time the tow vehicle, trailer loading or road surface conditions change or if you notice trailer wheel lock-up at any time while you are towing.

Setting the trailer gain properly is needed for the best trailer stopping performance. A trailer that is over-gained may result in locked trailer brakes. A trailer that is under-gained may result in not enough trailer braking. Both of these conditions may result in poor stopping and stability of the vehicle and trailer.

### Trailer Gain Adjustment Procedure

- Adjust trailer gain in 0.5 step increments up to 10 gain setting by using the gain adjustment +/- buttons on the trailer brake control panel switch. Pressing and holding a gain button will cause the trailer gain to continuously increment or decrement. To turn the output to the trailer off, set the gain to zero.
- Drive the tow vehicle and trailer combination on a level surface representative of the towing condition and free of traffic at approximately 32–40 km/h (20–25 mph) and fully apply the manual trailer brake apply lever mechanism located on the

trailer brake control panel switch. Adjusting the trailer gain at slower speeds may result in an incorrect gain setting.

- Adjust the trailer gain to just below the threshold of trailer wheel lock-up. Trailer wheel lock-up may not occur if towing a heavily loaded trailer. In this case, adjust the trailer gain to the highest allowable setting for the towing condition.

### Trailer Brake Gain and Output Display

This display menu can be accessed by scrolling through the DIC menu, or any time the trailer gain +/- button is depressed, or the manual trailer brake apply lever is actuated. The trailer output is displayed from 0 to full output and indicates the output power provided to the trailer brakes, relative to the gain setting.

After the electrical connection is made to a trailer equipped with electric brakes or electric over hydraulic brakes, the TRAILER CONNECTED message will be displayed momentarily on the DIC. The Trailer Brake Display Page can be selected on the DIC showing TRAILER GAIN and OUTPUT, after all vehicle related service messages are acknowledged by the driver. Depending on which instrument panel cluster is in the vehicle, the DIC may display dashed lines, a greyed out display, or it may be blank signifying a disconnected trailer or a trailer brake fault condition.

### Trailer Brake Driver Information Center Indicators and Messages

#### Trailer Brake Detection

The K67 Trailer Brake Control Module constantly monitors the trailer auxiliary control circuit from Terminal C at the X88B Tow Vehicle electrical Receptacle. When a trailer is connected with trailer brakes, the K67 Trailer Brake Control Module senses the connection and alerts the driver with a Trailer Connected message. If the K67 Trailer Brake Control Module senses a fault, or the trailer becomes disconnected, the vehicle will alert the driver with a Check Trailer Wiring message.

The following indicators are used to inform the driver of several different conditions:

#### Trailer Connected

This message will be briefly displayed when a trailer with Electric or Electric Over Hydraulic brakes is first connected to the vehicle. This message will automatically turn off in about ten seconds. The driver can also acknowledge this message before it automatically turns off.

#### Check Trailer Wiring

This message will be displayed if:

- The system detects that a trailer with Electric or Electric Over Hydraulic brakes is connected to the vehicle and then the trailer harness becomes disconnected from the vehicle.
- The trailer connection is recognized initially and then a disconnect occurs while the vehicle is stationary. This message will automatically turn off in about thirty seconds. This message will also turn off if the driver selects to turn this message off or if the trailer harness is reconnected.

- A disconnect of the trailer wiring harness occurs while the vehicle is moving. The Check Trailer Wiring message will continue until the ignition is turned off. The message will also turn off if the driver selects to turn this message off or if the trailer harness is re-connected.
- There is an electrical fault in the wiring to the electric trailer brakes. The Check Trailer Wiring message will continue as long as there is an electrical fault in the trailer wiring. This message will also turn off if the driver acknowledges this message off.
- A poor connection at the 7-way connector may cause the Check Trailer Wiring message. Some aftermarket 7-way trailer side connector adapters or plugs may cause deformation or excessive wear to the vehicle's trailer terminals. It is recommended that you use an OEM or Pollak heavy duty 7-way trailer side connector adapter.

**Service Trailer Brake System**

This message will be displayed when there is a problem with the trailer brake control system. The trailer brake system may not be fully functional, or may not be functioning at all. The trailer brake system is designed to provide trailer braking, if possible, even when faults prevent it from being fully functional. This reduced functionality includes:

1. Providing trailer braking when the master cylinder pressure or brake pedal switch are faulted.
2. Providing trailer braking when hill start assist and trailer sway control communication is faulted.
3. Providing trailer braking when certain manual trailer brake apply lever faults are present.

**Trailer Tire Pressure Monitoring**

**Special Tools**

- EL-46079/J-46079 Tire Pressure Monitor Diagnostic Tool
- EL-50448 Tire Pressure Monitor Sensor Activation Tool
- EL-52641 Trailer Presence Simulator Tool

For equivalent regional tools, refer to Special Tools.

The Trailer Tire Pressure Monitor System is designed to monitor the pressure of the trailer tires, and warn the driver when a low pressure condition exists. Four Trailer Tire Pressure Monitor System sensors may be provided in the vehicle's glove box as an accessory when equipped. The system can accommodate a trailer with up to (6) tires if additional sensors are purchased from the dealership. Also, the system can be paired with up to (5) individual trailers. The sensors must be mounted onto each tire and wheel assembly, and the sensors must be learned by the vehicle by following the learning procedure as shown in the Trailing App section of this manual. For sensor installation assistance, please contact your trailer service center or tire service center. The Trailer Tire Pressure Monitor System sensors monitor the air pressure in the trailer tires and transmit the trailer tire pressure readings to a receiver located in the vehicle. The trailer tire pressure sensors can transmit up to 23 feet (7 meters) from the

hitch receiver of the vehicle. The tire pressure values can be viewed in the trailing app in the vehicle's center stack.

**Trailing Diagnostic Tools**

In some situations when diagnosing trailer tire pressure monitoring, trailer lighting, or integrated trailer brakes, it may be necessary to connect the vehicle to a trailer to confirm proper operation. Performing this activity may prove difficult in the service environment since trailers are not often available for diagnostic use, may have existing electrical issues outside of the issues a technician is attempting to diagnose, or simply may be too unwieldily to connect for diagnosis.

With all this in mind, it may be helpful to build or create a tool that can be plugged into the vehicle's trailer connector and simulate a connected trailer. This tool would include park lamps, stop lamps, and a reverse lamp for lighting and trailer tire pressure monitoring diagnosis. It can be expanded to include trailer brake magnets to diagnose integrated trailer brake concerns. Also, an additional lamp can be included to diagnose the B+ circuit to the trailer.

Trailer issues are NOT covered under warranty, but these tools may be used to verify the vehicle is functioning properly and to help the customer understand and correct any trailer related issues if they so choose.

**Available Trailer Presence Simulator Tool**

Illustration	Tool Number/Description
 <p style="text-align: right; font-size: small;">5166189</p>	<p style="text-align: center;">EL-52641 Trailer Presence Simulator Tool</p>

**Simulated Trailer Lighting**

Creating a tool to simulate a connected trailer can be used to diagnose issues with trailer lighting, trailer brake (if equipped), the Trailing App (if equipped), and trailer tire pressure monitoring system (if equipped).

If the vehicle is equipped with a K68 Trailer Lamp Control Module (U1D/UET), the module monitors the current on the lighting circuits to determine a trailer has been connected. The Trailer Lamp Control Module pulses current on the trailer lighting circuits every 42 minutes to monitor for a connected trailer. If a current draw greater than 55mA is detected, the Trailer Lamp Control Module recognizes this as a connected trailer. This will enable any trailer lighting controlled by the Trailer Lamp Control Module. The Center Stack Module will also use this trailer detection as a cue to enable the Trailing App and trailer tire pressure monitoring functions.



### Creating a Simulated Trailer Lighting Tool

Parts needed:

- 7-way RV trailer connector Qty: 1
- Note:** The combination trailer stop/turn, and backup lamps must draw at least 55mA of total current to be detected as a trailer. Some LED combination lamps will not draw enough current. If an LED combination lamp is used, make sure it draws at least 55mA. A load resistor can be added to the circuit if necessary to obtain the correct load.
- Combination trailer park/stop/turn lamp (greater than 55mA drawn when on) Qty: 2
  - Reverse lamp Qty: 1
  - 12 gauge wire and terminals/connectors Qty: As needed
  - 18 gauge wire and terminals/connectors Qty: As needed
  - Mounting board Qty: 1
1. Connect a 12 gauge wire to the ground terminal of the 7-way trailer connector and the ground circuit of each combination trailer park/stop/turn lamp and the reverse lamp in parallel.
  2. Connect an 18 gauge wire between the park lamp terminal of the 7-way trailer connector and the park lamp circuit of each combination trailer park/stop/turn lamp in parallel.
  3. Connect an 18 gauge wire between the left turn/stop lamp terminal of the 7-way trailer connector and the turn/stop lamp circuit of left trailer park/stop/turn lamp.
  4. Connect an 18 gauge wire between the right turn/stop lamp terminal of the 7-way trailer connector and the turn/stop lamp circuit of right trailer park/stop/turn lamp.
  5. Connect an 18 gauge wire between the reverse lamp terminal of the 7-way trailer connector and the reverse lamp.
- Note:** A combination trailer lighting and trailer brake tool can be created on the same mounting board.
6. Mount the left combination trailer park/stop/turn lamp, right combination trailer park/stop/turn lamp, and reverse lamp to the mounting board.
  7. Plug the 7-way RV trailer connector to the vehicle and verify functionality.

### Simulated Trailer Brakes

Creating a tool to simulate trailer brakes can be used to diagnose trailer brake issues.

The trailer brake control system is compatible with two types of trailer brake systems: electromagnetic or electro-over hydraulic trailer brakes. The Brake System Control Module must determine which type of brakes the trailer is equipped with so the system can output correctly for the trailer's brake system. Because the Brake System Control Module has to determine the type of trailer brake system that is being used, it can be sensitive to a variety of trailer wiring issues.

The Trailer Brake Control Module continuously sends a test pulse out on the trailer brake control circuit (circuit 47) to determine if a trailer with trailer brakes has been

connected. How the pulse reacts when a trailer is connected is how the Trailer Brake Control Module determines which type of braking system the trailer is equipped with.

Even after the system detects the trailer, Trailer Brake Control Module will continue to send this test pulse on the trailer brake control circuit, which now is monitoring both the truck and trailer circuitry. The trailer brake control circuit continues to be monitored for any faults so the driver can be notified of any issues that may occur within the truck or trailer, as well as, to determine when the trailer is disconnected from the truck.

### Creating a Simulated Trailer Brake Tool

Parts needed:

- 7-way RV trailer connector Qty: 1
  - Electric trailer brake magnets Qty: 2, 4, 6, or 8
  - Reverse lamp Qty: 1
  - Mounting board Qty: 1
  - 12 gauge wire and terminals/connectors Qty: As needed
1. Connect a 12 gauge wire to the ground terminal of the 7-way trailer connector.
  2. Connect a 12 gauge wire to the brake controller output terminal of the 7-way trailer connector.
- Note:** The trailer brake magnets must be connected in parallel. Connecting in series will create an excessive current draw and disable the trailer brake system.
3. Connect the trailer brake magnets to the 12 gauge wires from the 7-way trailer connector in parallel.
- Note:** A combination trailer lighting and trailer brake tool can be created on the same mounting board.
4. Mount the trailer brake magnets to the mounting board.
  5. Plug the 7-way RV trailer connector to the vehicle and verify functionality.

# Vehicle Access

## Schematic and Routing Diagrams

Door Lock/Indicator Schematics (Driver Door Switch Panel Control Module Power, Ground, Serial Data, and Subsystem References)

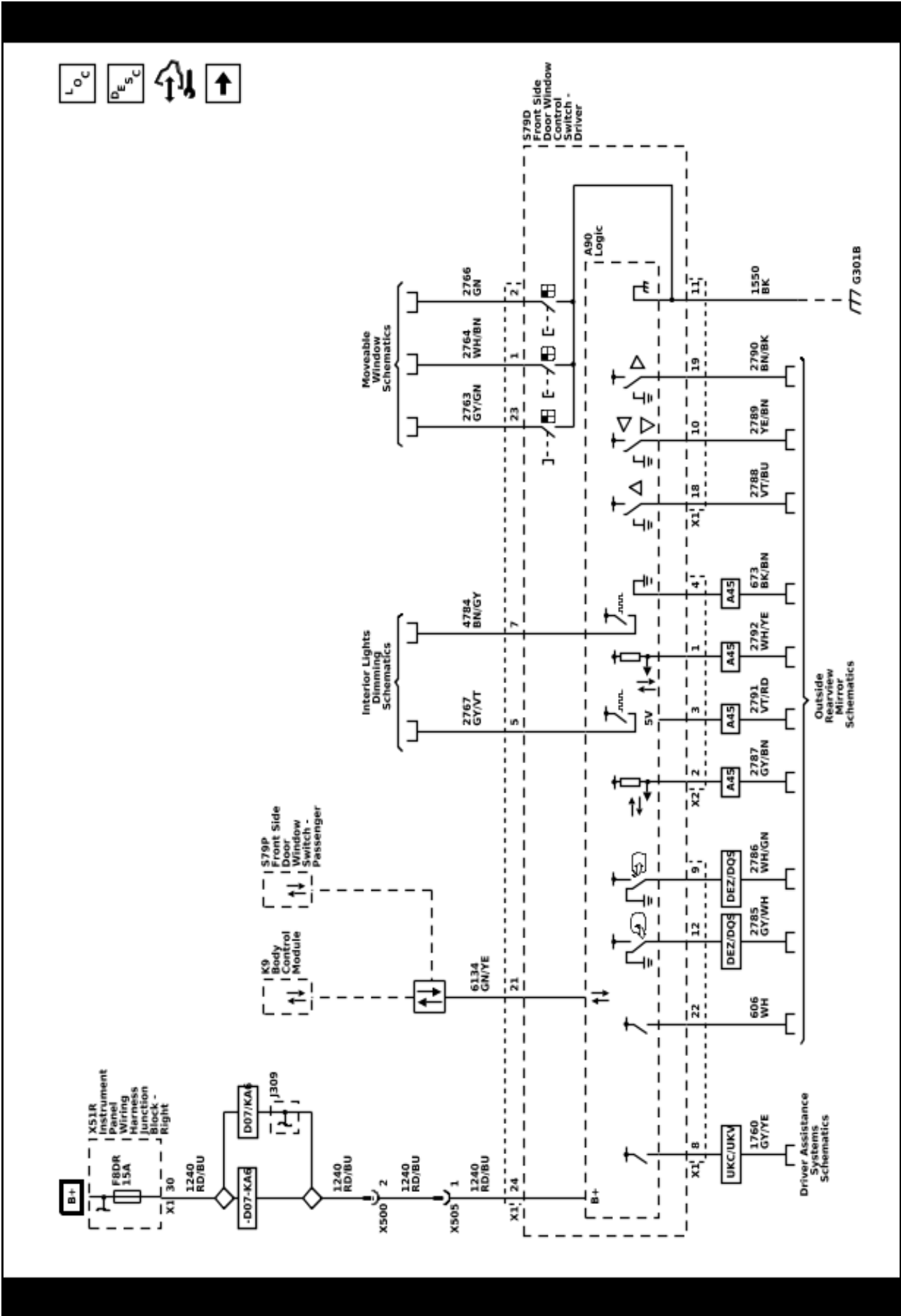

Door Lock/Indicator Schematics (Passenger Door Switch Panel Control Module Power, Ground, Serial Data, and Subsystem References)

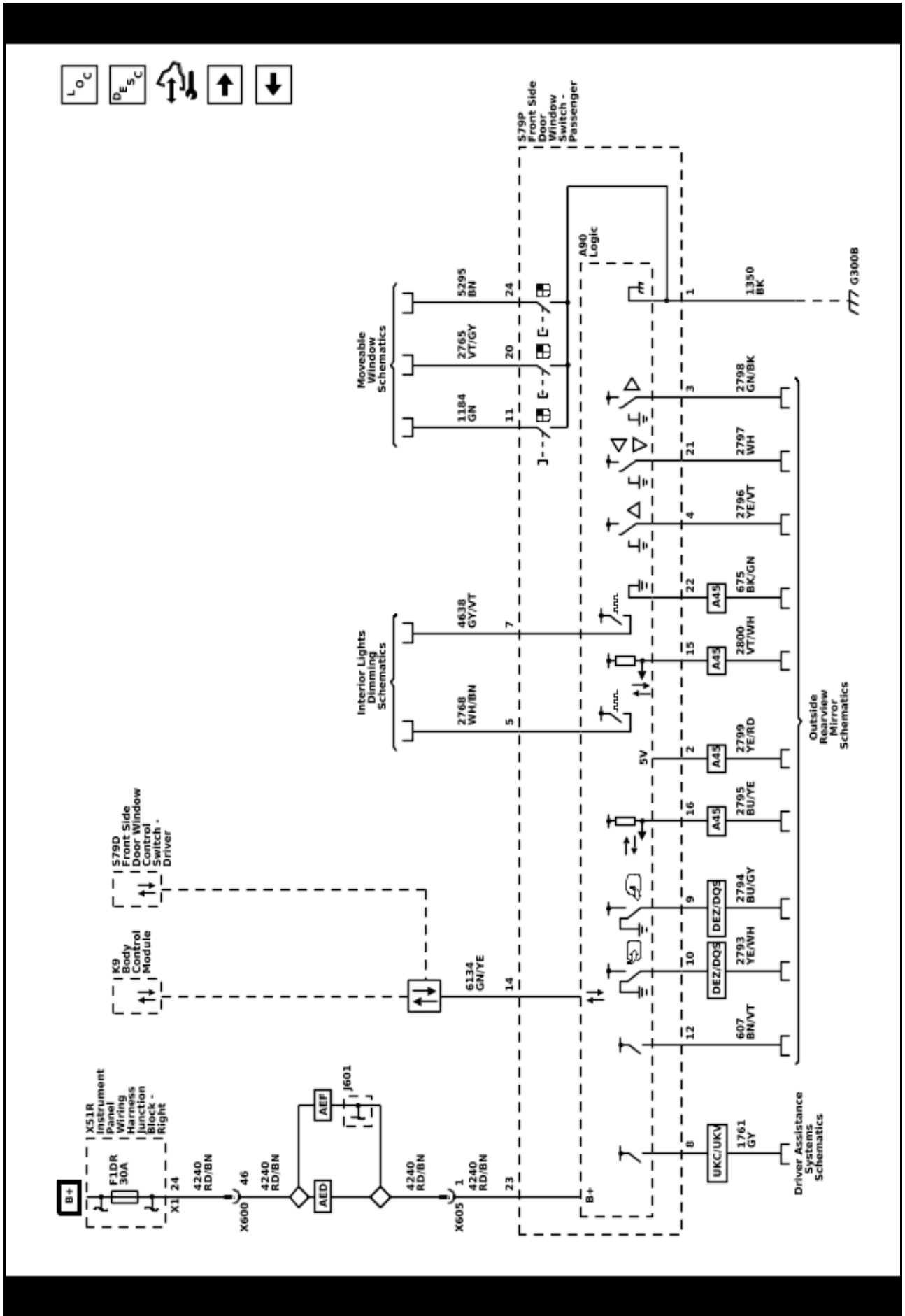

Door Lock/Indicator Schematics (Door Lock Switches and Indicators)

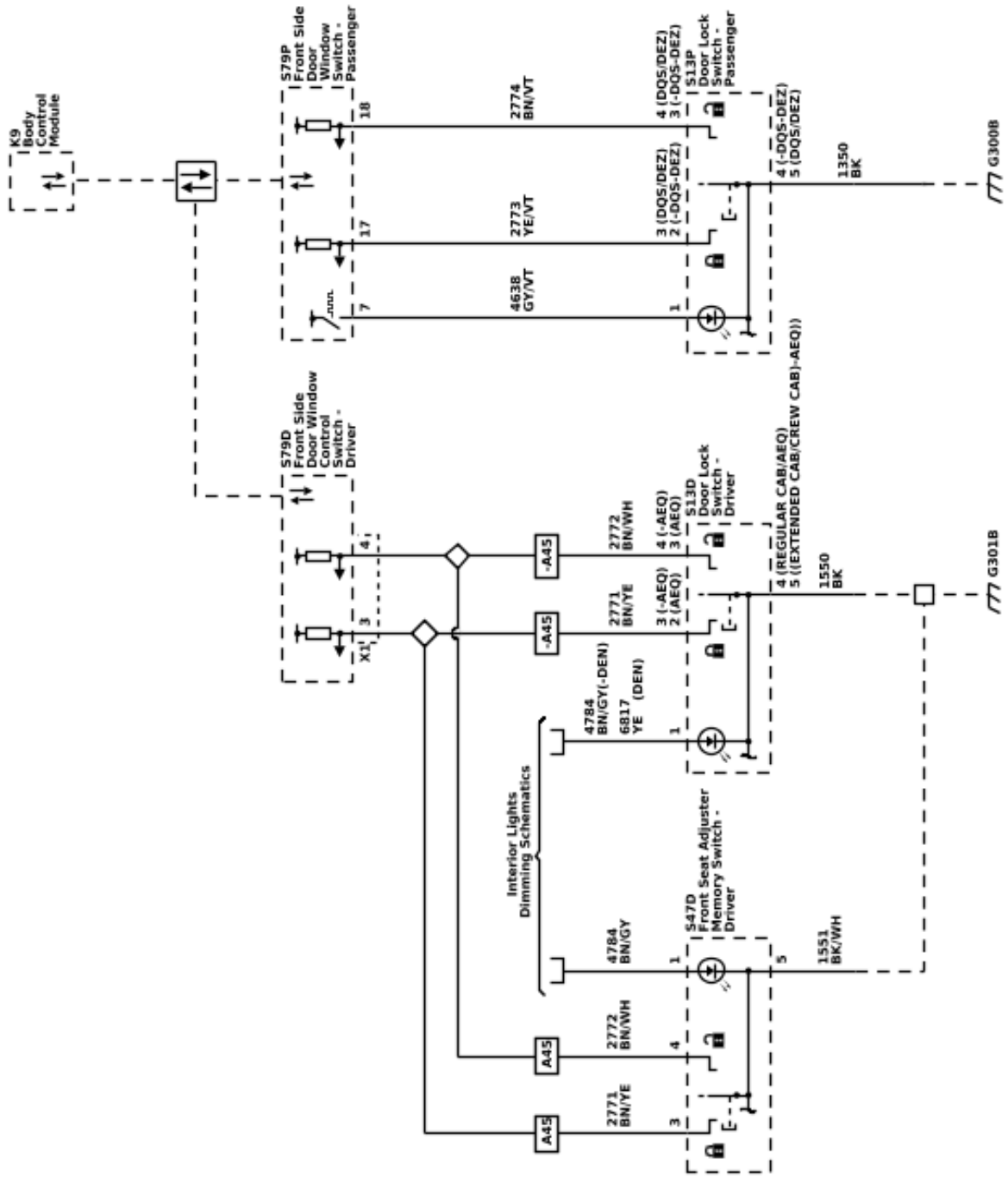



Door Lock/Indicator Schematics (Ajar Switches, Lock Status and Child Lock Status)

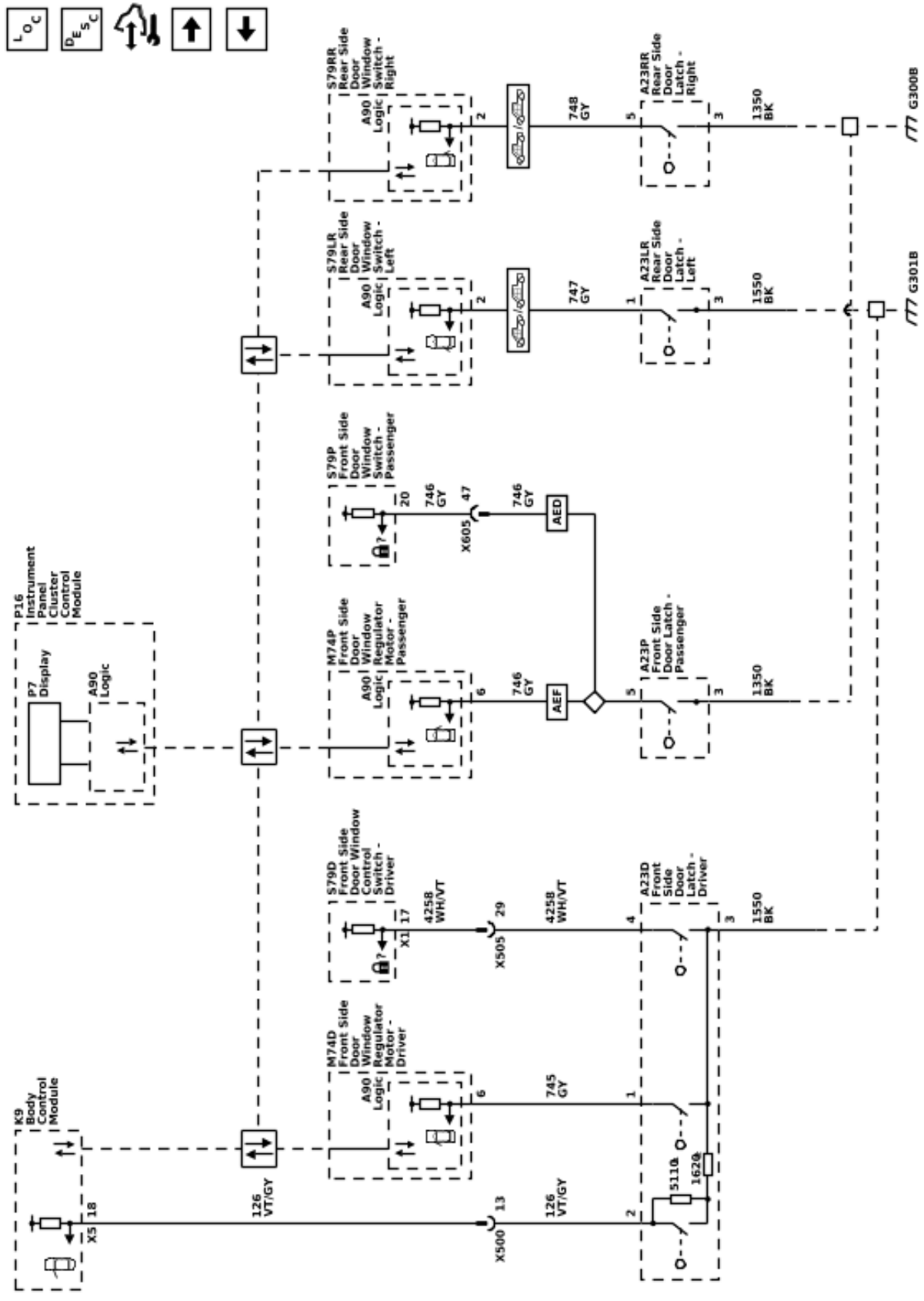

Door Lock/Indicator Schematics (Actuators)

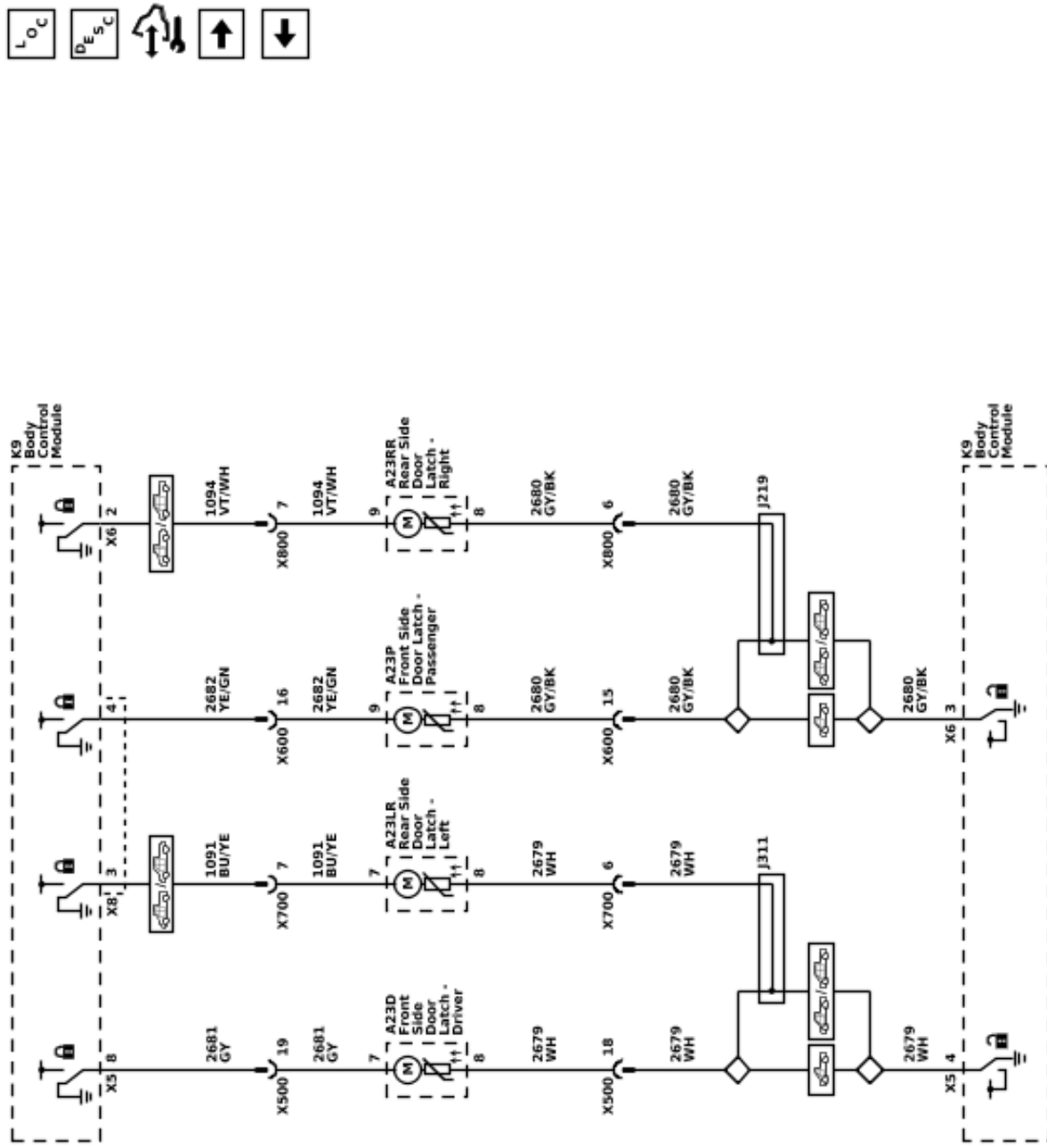

Door Lock/Indicator Schematics (Door Handle Switches)

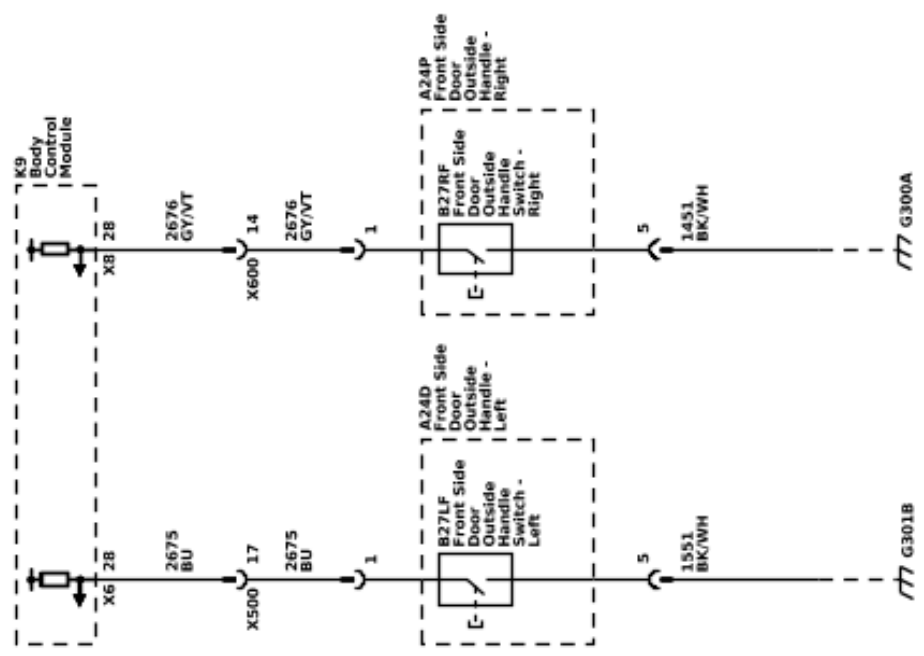
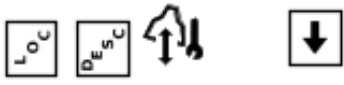

Release Systems Schematics (Endgate Release (QT5))

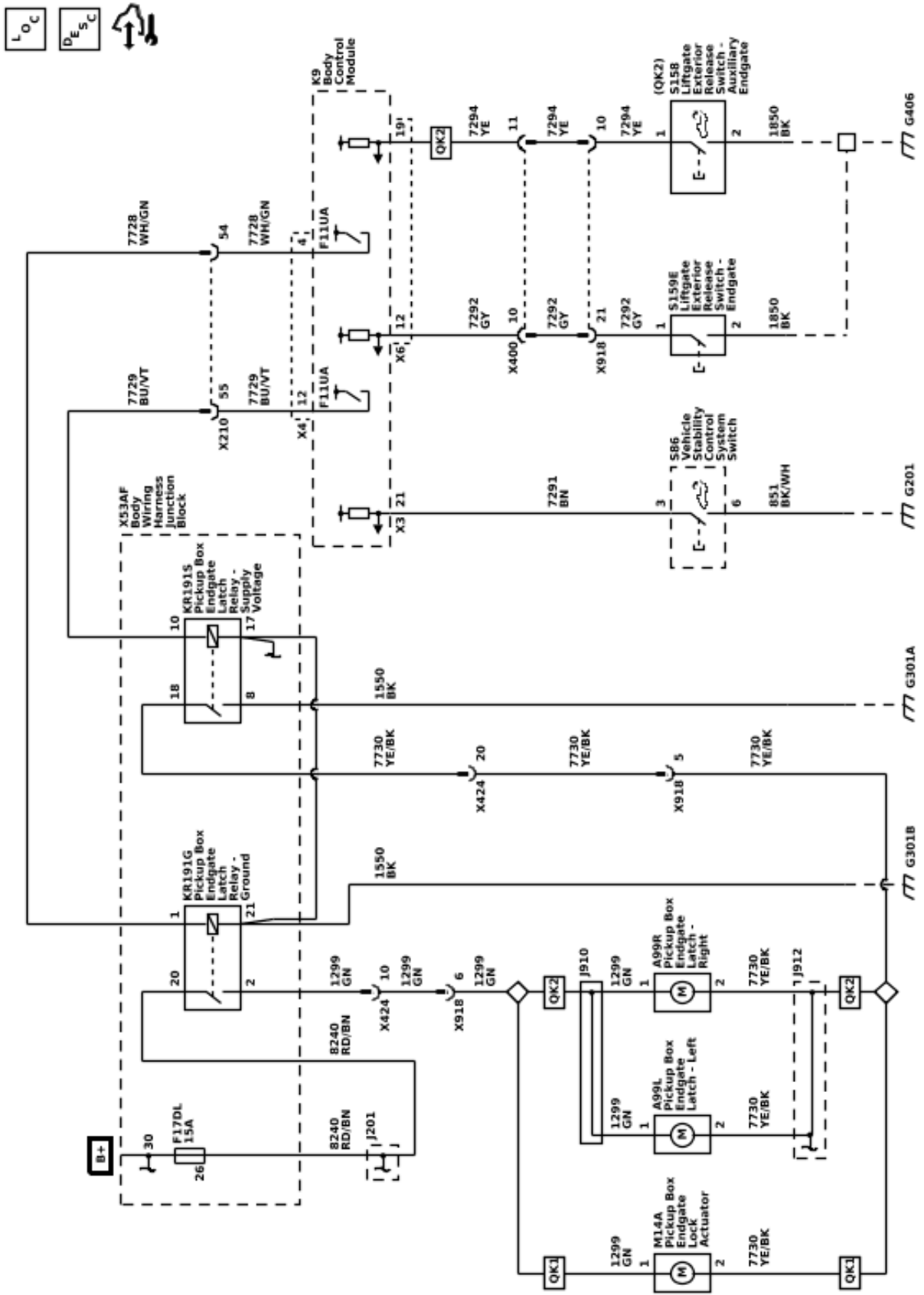

6278791

Endgate Schematics (Power Endgate Controls (QT6))

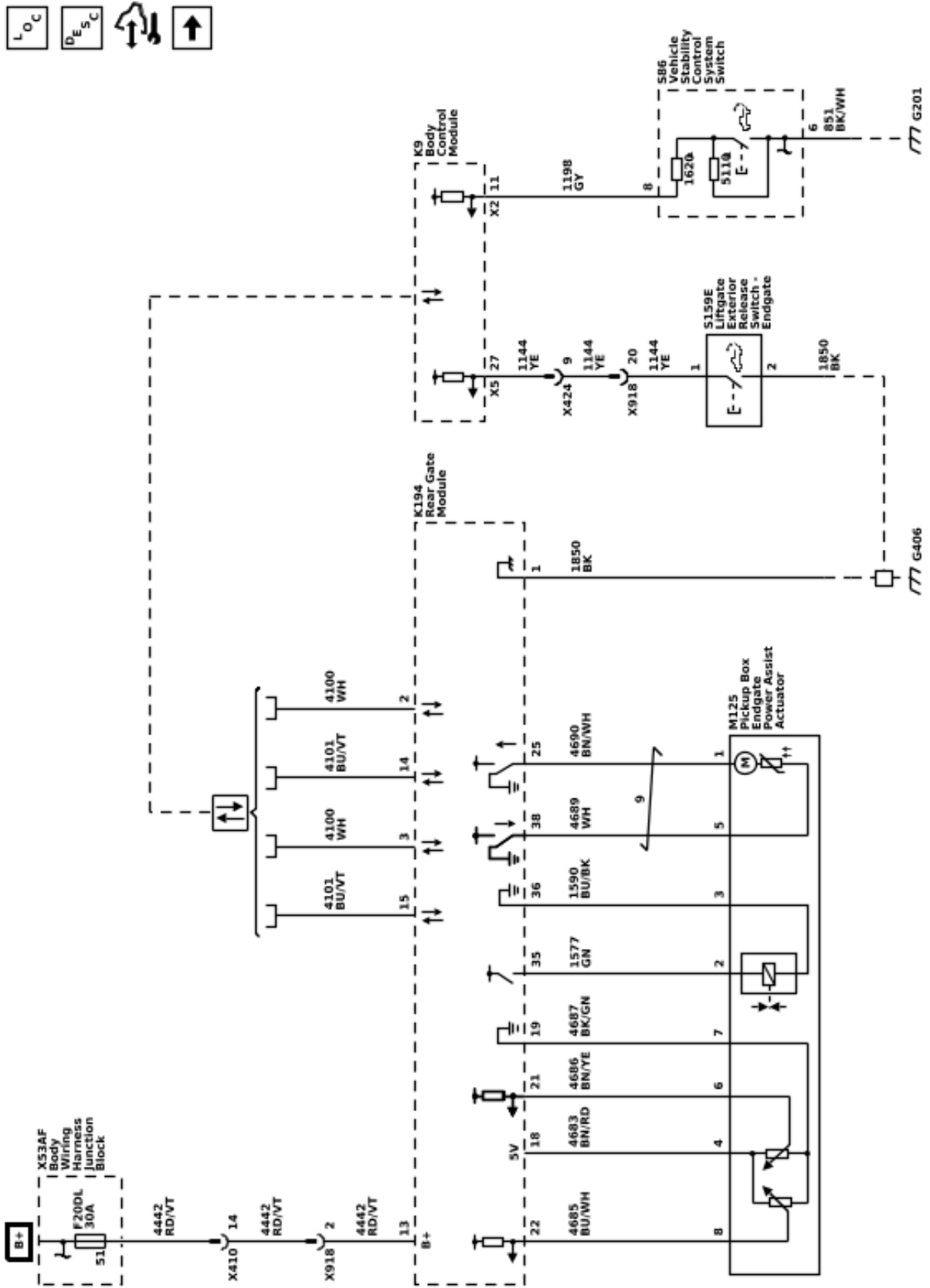

Endgate Schematics (Power Endgate Latches (QT6))

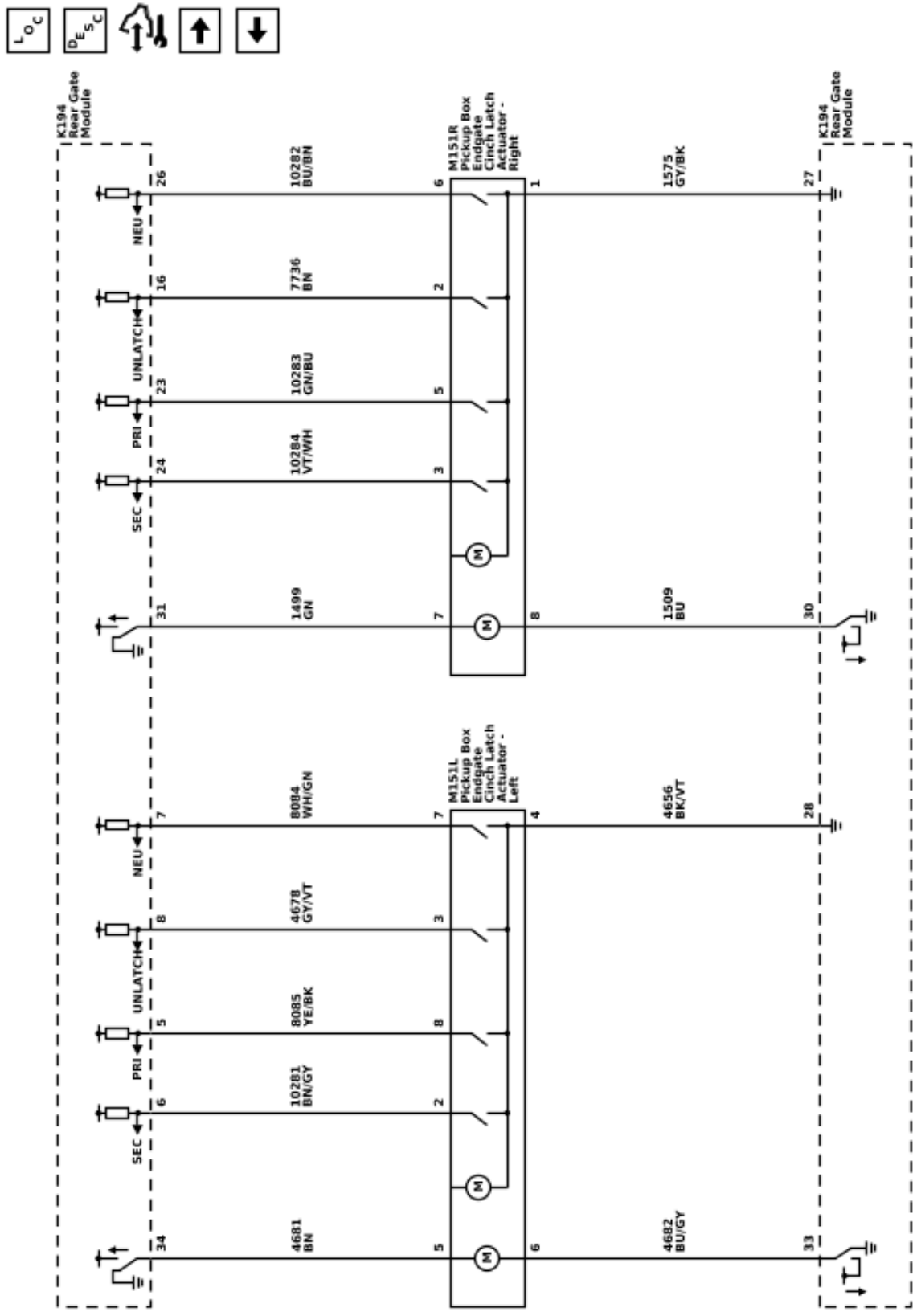

Endgate Schematics (Auxiliary Endgate Latch Controls and Switches (QK2 & QT5))

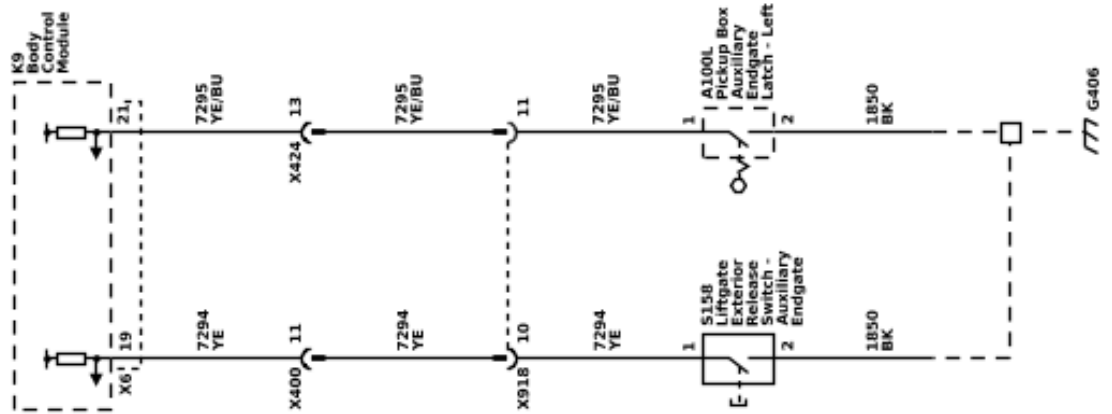

Endgate Schematics (Auxiliary Endgate Latch Motors (QK2))

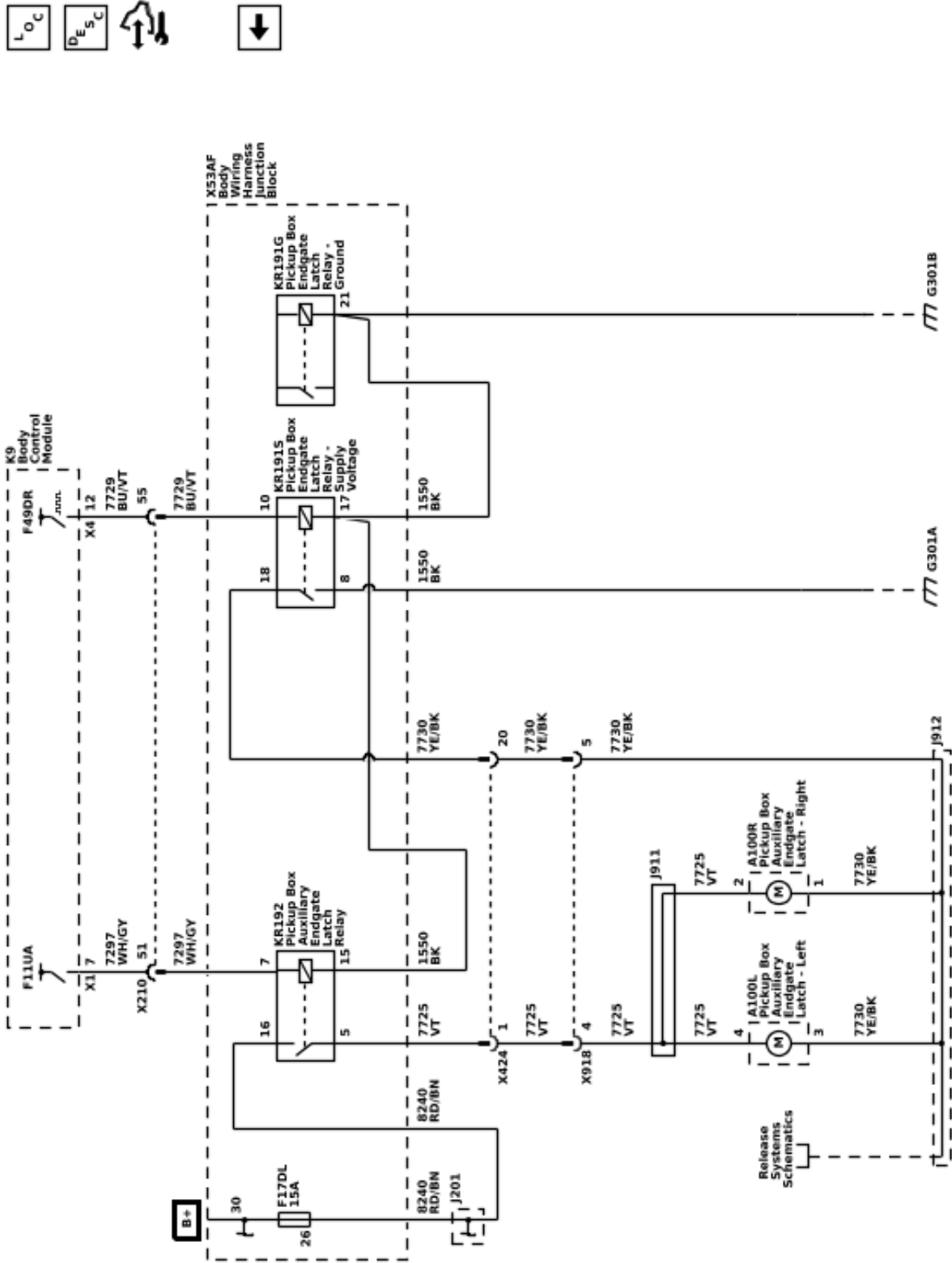



Hood Latch Schematics (Engine Compartment Cover Switch)

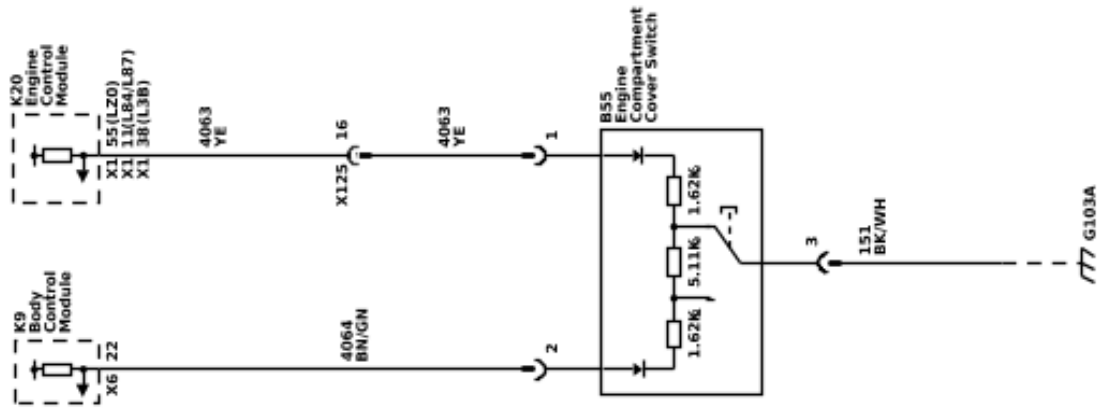

## Description and Operation

### Door Ajar Indicator Description and Operation

#### Door Ajar Indicator System Components

The door ajar indicator system consists of the following components:

- Body control module (BCM)
- Instrument cluster
- Driver door latch
- Passenger door latch
- Left rear door latch
- Right rear door latch
- Driver window motor
- Passenger window motor
- Left rear side door window switch
- Right rear side door window switch

#### Driver and Passenger Door Ajar

The window motor supplies a 12 V signal to the door ajar switch within the door latch, when a door is open the door ajar switch closes pulling the 12 V signal low. When the window motor detects the drop in the 12 V signal circuit, it will then communicate this status to the BCM via local interconnect network (LIN) bus. The BCM communicates with the instrument cluster via serial data message. The instrument cluster, upon receipt of this serial data message, will illuminate the door ajar indicator and also send a serial data message to the radio to activate the door ajar audible warning when the vehicle speed is greater than 8 km/h (5 mph).

#### Rear Doors Ajar

The rear side door window switches each provide a 12 V signal to their respective door ajar switch signal circuits. The rear door ajar switches are integral to each rear door latch assembly. When a rear door is opened, the normally open door ajar switch closes. With the door ajar switch closed, ground is provided to the door ajar switch signal circuit and the voltage within the signal circuit drops. The rear side door window switches will detect the voltage drop and will send a serial data message to the body control module which will then send a message to the instrument cluster to command the door ajar message

## Endgate Description and Operation (QT6)

### System Description

The power endgate system consists of the following components:

- Rear gate module
- Pickup box endgate power assist actuator
- Pickup box endgate position sensor (part of the power assist actuator)
- Interior pickup box endgate control switch (Part of the Instrument panel multifunction switch)
- Exterior pickup box endgate control switch

- Right pickup box endgate latch assembly
- Left pickup box endgate latch assembly
- Keyless entry transmitter
- Remote control door lock receiver

### Operation

The power endgate can be commanded to power open by the following methods:

- Pressing the interior pickup box endgate control switch on the center stack
- Pressing the touch pad on the exterior endgate handle (vehicle doors must be unlocked)
- Pressing the endgate button on the RKE transmitter twice and holding until the endgate latches release

The power endgate can be commanded to power close by the following methods:

- Pressing and holding the interior pickup box endgate control switch on the center stack until the endgate is fully closed and latched
- Pressing the touch pad on the exterior endgate handle
- Pressing the endgate button on the RKE transmitter twice and holding until the endgate is fully closed and latched
- Lifting the tailgate at least 10 cm (4 in) above the full close position and holding momentarily

The vehicle must be in Park for any of the power tailgate functions to operate.

The rear gate module will respond to a request by commanding the left and right pickup box endgate latches to release the endgate and activate the pickup box endgate power assist actuator and lower the endgate or to raise and cinch the endgate closed.

### Power Latch

The rear gate module continuously monitors power endgate operation and calculates its location and direction of travel from an endgate position sensor (part of the power assist actuator). One input returns the position of the endgate relative to the x-axis and y-axis. The rear gate module then uses these 2 inputs together to calculate its angle relative to the endgate.

The left and right pickup box endgate latches are bi-directional motors and latch or unlatch operation is the result of the direction of the motor rotation. The rear gate module controls the left and right pickup box endgate latches through the control circuits by supplying power and ground in the appropriate polarity. The motor control circuits are monitored by the rear gate module prior to activation for a high or low condition and during motor operation for an insufficient current flow condition. The ratchet, pawl and sector switches are part of the left and right pickup box endgate latches and are used by the rear gate module to determine the state of the latch during the process of latching or unlatching. Each of the latch switch signal circuits are supplied battery voltage and monitored within the rear gate module. The latch switches share a common low reference circuit from the rear gate module and when the switch contacts close the signal circuit goes low and the rear gate module determines the switch to be active. The ratchet, pawl and unlatch

switches are inactive when the endgate is closed and will transition to active as the endgate is opened. The sector switch will be inactive when the endgate is closed, during opening of the endgate the sector switch will change to active and back to inactive when the endgate is in the fully open position.

The exterior pickup box endgate control switch signal circuit is supplied battery voltage by the rear gate module. When the switch is pressed the contacts close and the signal circuit goes low, the rear gate module will detect the voltage drop and will command the endgate to release and lower or to power raise the endgate to the closed position.

For vehicles without the optional passive keyless entry, when the exterior pickup box endgate control switch is pressed, the rear gate module will check the status of the vehicle door locks by sending a serial data message to the body control module requesting the door lock status. If the vehicle doors are locked, the rear gate module will ignore the signal from the exterior pickup box endgate control switch. If the vehicle doors are unlocked, the rear gate module will permit the endgate to unlatch and power open when the exterior pickup box endgate control switch is pressed.

For vehicles with the optional passive keyless entry system, the keyless entry control module monitors the proximity of the keyless entry transmitter. If the exterior pickup box endgate control switch is pressed and the keyless entry transmitter is within range, the keyless entry control module will send a serial data message to the rear gate module indicating the presence of the keyless entry transmitter and the rear gate module will permit the endgate to unlatch and power open. If the doors are locked and the keyless entry transmitter is not within range, the rear gate module will ignore the signal from the exterior pickup box endgate control switch.

## Manual Endgate Operation

The endgate can be manually closed from the full-open position when the endgate is lifted in a continuous motion. If the endgate motion is stopped between the full-open and half-closed positions, the lift to close feature can engage and power close the endgate. If the touch pad is pressed during power operation, the endgate will stop and allow manual operation. The endgate must be held after stopping, or it will continue to open.

## Tailgate Release Unavailable Driver Information Center Message

### Power Endgate Functions Disabled Without Setting DTCs

The driver information center displays Tailgate Release Unavailable when a thermal inhibit occurs in the latch or drive unit or the position count is out of range.

The power endgate functions will be restored by performing the following actions:

- Closing the endgate which will reset the position counts
- Closing the endgate and removing the F20DL 30A fuse for greater than 5 minutes

### Power Endgate Functions Disabled With DTCs Current

The driver information center displays Tailgate Release Unavailable when the rear gate module control module detects a malfunction in the power endgate system and the system is disabled.

## Endgate Description and Operation (QT5 Without MultiPro Tailgate)

### Endgate Release System Components

- Body control module (BCM)
- Pickup box endgate control switch-interior (Part of the instrument panel multifunction switch)
- Pickup box endgate control switch-exterior
- Pickup box endgate unlatch actuator
- Pickup box endgate unlatch relay

## Endgate Release Operation (Without MutiPro Tailgate Option)

### Interior Endgate Release Switch

The body control module monitors the voltage level of the endgate unlatch signal circuit so that when the switch is pressed contacts within the switch closes providing a ground path for the endgate unlatch signal circuit, the voltage within the signal circuit is pulled low, the body control module will detect the voltage drop and if the passenger doors are unlocked, will energize the pickup box endgate unlatch relay.

### Exterior Endgate Release Switch

The body control module monitors the status of the vehicle doors, if the doors are locked the body control module will ignore the request from the exterior pickup box endgate control switch. If the passenger doors have been commanded to unlock, pressing the exterior pickup box endgate control switch will close contacts within the switch and provide a ground path for the endgate unlatch signal circuit, the body control module will detect the voltage drop and will energize the pickup box endgate unlatch relay.

If the vehicle has been equipped with the passive keyless entry system and the keyless entry transmitter is within 3 feet (1 meter) of the endgate, pressing the exterior pickup box endgate control switch will also function in the same manner but without unlocking the passenger doors. Refer to Keyless Entry System Description and Operation for more information on the passive keyless entry system.

### Pickup Box Endgate Unlatch actuator

When body control module receives a endgate release command from the exterior pickup box endgate control switch, the body control module applies brief pulse of voltage to the pickup box endgate unlatch relay control circuit, which energizes the coil side of the relay. The switch side of the pickup box endgate unlatch relay then momentarily closes, supplying a brief pulse of battery positive voltage to the pickup box endgate unlatch actuator. The pickup box endgate unlatch actuator is continuously grounded and when it receives

the voltage pulse, it will become energized and the latch will activate releasing the endgate so that it may be manually lowered to an open position.

## Endgate Description and Operation (QT5 With MultiPro Tailgate)

### Endgate Release System Components

- Body control module (BCM)
- Pickup box endgate control switch-interior (Part of the instrument panel multifunction switch)
- Pickup box endgate control switch-exterior
- Left pickup box endgate latch
- Right pickup box endgate latch
- Left pickup box auxiliary endgate latch
- Right pickup box auxiliary endgate latch
- Left pickup box endgate latch relay
- Right pickup box endgate latch relay
- Left pickup box auxiliary endgate latch relay
- Right pickup box auxiliary endgate latch relay

### Endgate Release Operation (With MutiPro Tailgate Option)

#### Interior Endgate Release Switch

The body control module monitors the voltage level of the endgate unlatch signal circuit so that when the switch is pressed contacts within the switch closes providing a ground path for the endgate unlatch signal circuit, the voltage within the signal circuit is pulled low, the body control module will detect the voltage drop and if the passenger doors are unlocked, will energize the left pickup box endgate latch relay and right pickup box endgate latch relay.

#### Exterior Endgate Release Switch

The body control module monitors the status of the vehicle doors, if the doors are locked the body control module will ignore the request from the exterior pickup box endgate control switch. If the passenger doors have been commanded to unlock, pressing the appropriate exterior pickup box endgate control switch will close contacts within the switch and provide a ground path for the major or minor endgate unlatch signal circuit, the body control module will detect the voltage drop and will energize the appropriate pickup box endgate latch relays.

If the vehicle has been equipped with the passive keyless entry system and the keyless entry transmitter is within 3 feet (1 meter) of the endgate, pressing the exterior pickup box endgate control switch will also function in the same manner but without unlocking the passenger doors. Refer to Keyless Entry System Description and Operation for more information on the passive keyless entry system.

#### Major Pickup Box Endgate

**Note:** The auxiliary pickup box endgate must be in the latched position before commanding the major pickup box endgate to release. The body control module will disable the major pickup box endgate release function if the auxiliary pickup box endgate is open or ajar.

When body control module receives a major endgate release command from the exterior pickup box endgate control switch, the body control module applies brief pulse of voltage to the left and right pickup box endgate latch relay control circuits, which energizes the coil side of the relays. The switch side of the left and right pickup box endgate latch relay then momentarily closes, supplying a brief pulse of battery positive voltage to the left and right pickup box endgate latches. The left and right pickup box endgate latches will become energized and the latches will activate releasing the major endgate so that it may be manually lowered to an open position.

#### Minor Pickup Box Endgate

When body control module receives a major endgate release command from the exterior pickup box endgate control switch, the body control module applies brief pulse of voltage to the left and right pickup box auxiliary endgate latch relay control circuits, which energizes the coil side of the relays. The switch side of the left and right pickup box auxiliary endgate latch relay then momentarily closes, supplying a brief pulse of battery positive voltage to the left and right pickup box auxiliary endgate latches. The left and right pickup box auxiliary endgate latches will become energized and the latches will activate releasing the minor endgate so that it may be manually lowered to an open position.

## Hood Ajar Indicator Description and Operation

### Hood Ajar Switch

The body control module (BCM) applies B+ to the hood ajar signal circuit and monitors the voltage to determine the position of the hood. When the hood is open, the switch is open and voltage remains high. When the hood is closed, the switch is closed and the voltage is pulled low.

The BCM uses the hood ajar switch as a content theft deterrent alarm trigger.

### Hood Ajar Indicator/Message

When the hood is ajar, a message is displayed on the DIC or the hood ajar indicator will be illuminated.

## Power Door Locks Description and Operation

### Door Lock System Components

The power door lock system consists of the following components:

- Driver door lock switch
- Passenger door lock switch
- Left rear door lock switch
- Right rear door lock switch
- Driver front side door window control switch
- Passenger front side door window switch
- Driver front side door latch
- Passenger front side door latch
- Left rear side door latch
- Right rear side door latch
- Exterior door handle switches

- Body control module
- Lighting control module

## Door Lock System Controls

The power door lock system can be controlled by any of the following:

- Power door lock switch activation
- Keyless entry lock or unlock command
- Delayed locking command
- Automatic door lock command
- When the OnStar<sup>®</sup> system is used to unlock the driver door

## Door Lock and Unlock Operation

The driver or passenger front side door window control switch will monitor the voltage of their respective door lock switches, when the driver or passenger door lock switch is activated in the lock or unlock position the signal voltage will be pulled low, the corresponding front side door window control switch will detect the voltage drop in the signal circuit and will send a serial data message to the body control module requesting the door lock or unlock command.

The lighting control module will monitor the voltage of the left rear and right rear door lock switches, when the left rear or right rear door lock switch is activated in the lock or unlock position the signal voltage will be pulled low, the lighting control module will detect the voltage drop in the signal circuit and will send a serial data message to the body control module requesting the door lock or unlock command.

The body control module upon receipt of a lock or unlock request, will supply battery voltage to the door lock actuator lock or unlock control circuits. Since the opposite side of the lock actuator is connected to ground through the other lock actuator control circuit, the doors, and fuel filler door will then lock or unlock as commanded.

The following control circuits are used to operate the door lock actuators:

- Driver door unlock only
- Passenger and rear door unlock
- All door lock

This sequence can be modified through the personalization settings

## Passive Door Lock/Unlock Operation

The exterior door handle switch signal circuits provide inputs to the body control module when the exterior door handle switches are activated. These inputs allow the body control module to detect a door lock or a door unlock request. The body control module provides a 7 V signal to each exterior door handle switch via the door handle switch signal circuits. When a door handle switch is pressed, the switch closes and the voltage signal within the signal circuit is pulled to ground. The body control module will detect the voltage drop and a low frequency antenna will transmit a challenge to the keyless entry transmitter. If the challenge is met, the keyless entry transmitter will respond, and the body control module will command the door(s) to be locked or unlocked.



**BLANK**

## Section 3

# Driver Information and Entertainment

<b>Image Display Cameras</b> .....	<a href="#">3-3</a>
<b>Schematic and Routing Diagrams</b> .....	<a href="#">3-3</a>
Image Display Camera Schematics .....	<a href="#">3-4</a>
<b>Description and Operation</b> .....	<a href="#">3-7</a>
Rearview Camera Full Display Mirror Description and Operation .....	<a href="#">3-7</a>
Rear Vision Camera Description and Operation .....	<a href="#">3-7</a>
Surround Vision Camera Description and Operation .....	<a href="#">3-7</a>

**BLANK**



# Image Display Cameras

## Schematic and Routing Diagrams

Image Display Camera Schematics (Rearview Driver Information Camera (UVB))

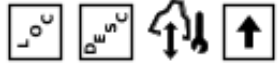
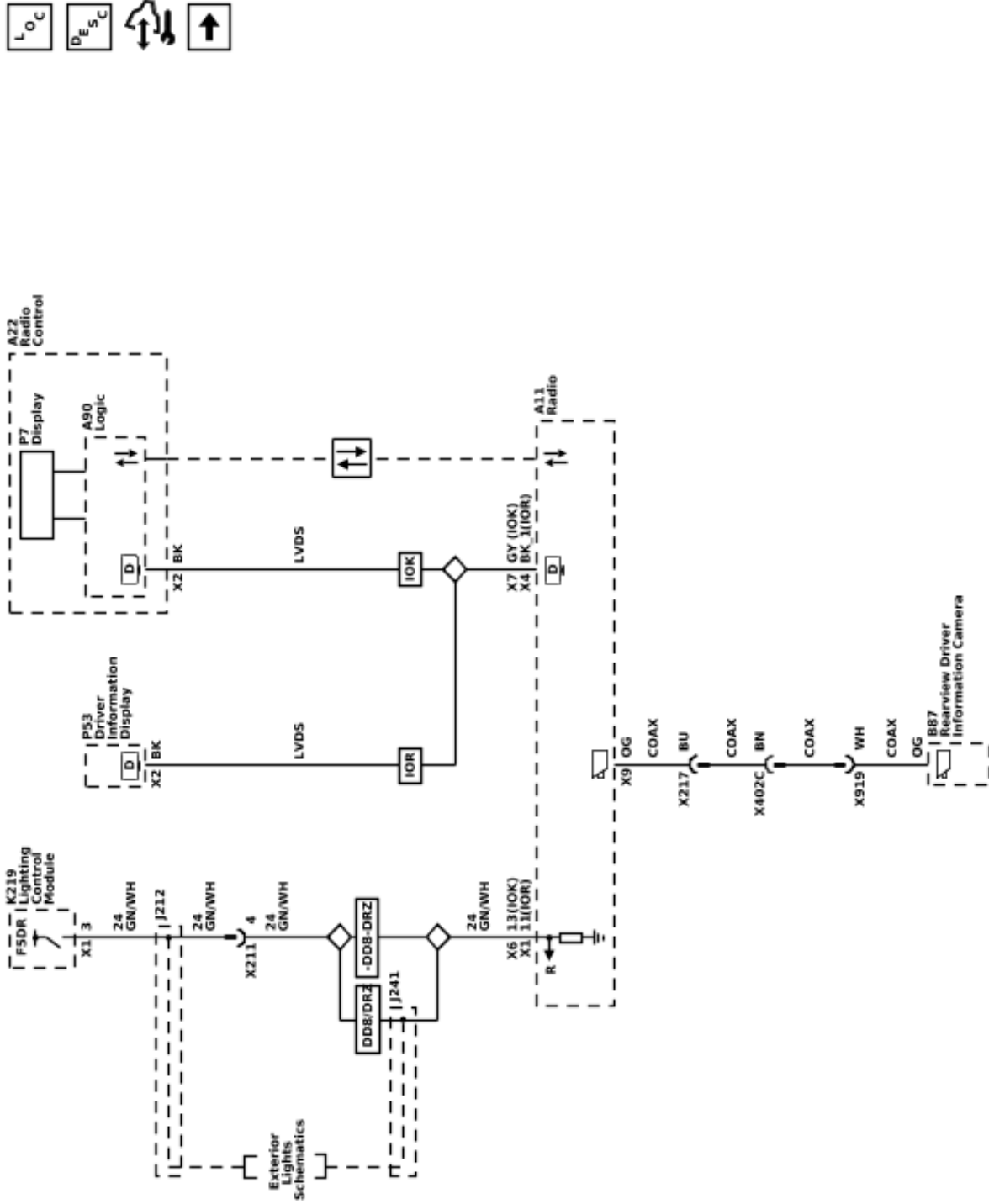

Image Display Camera Schematics (Inside Rearview Mirror Camera (DRZ))

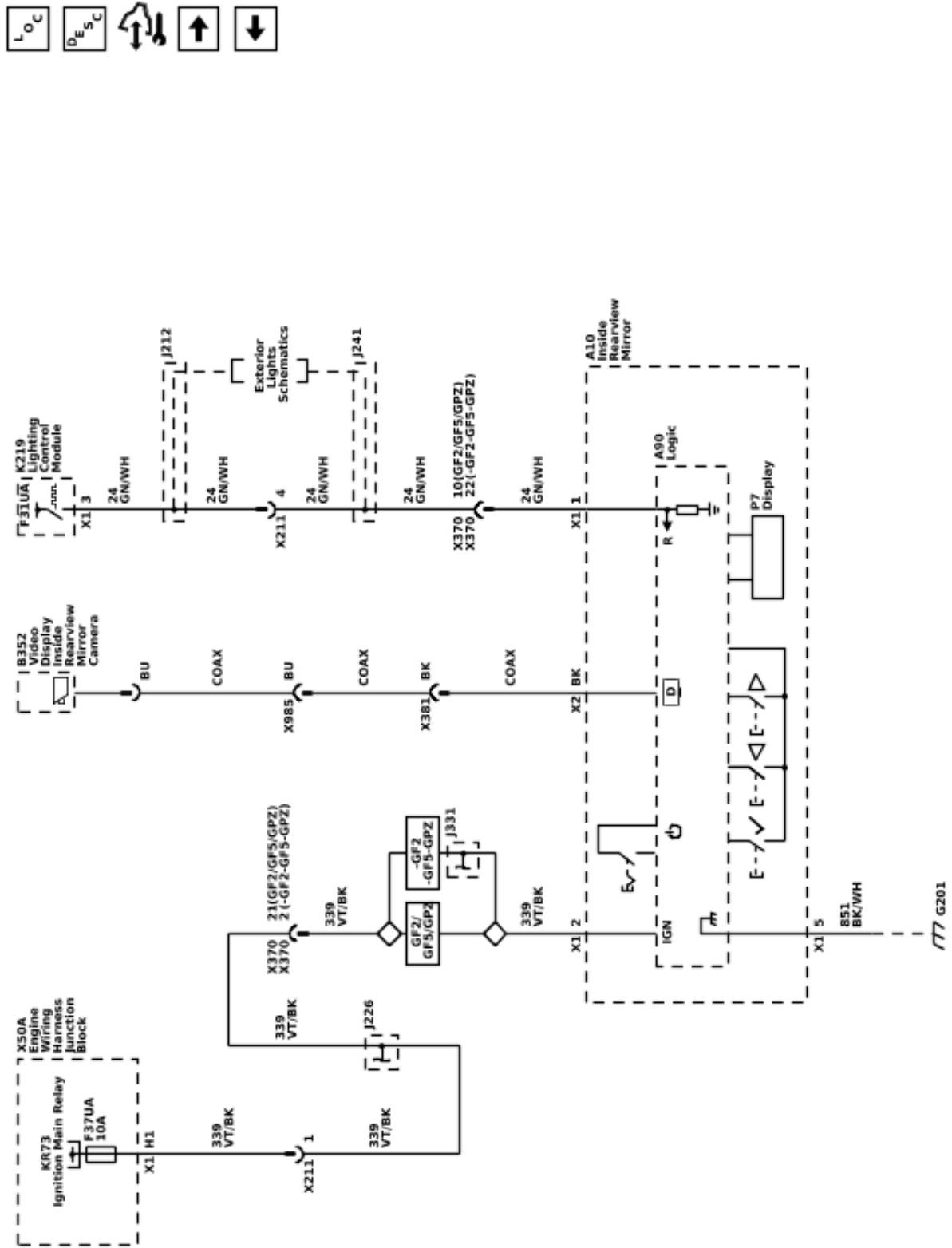
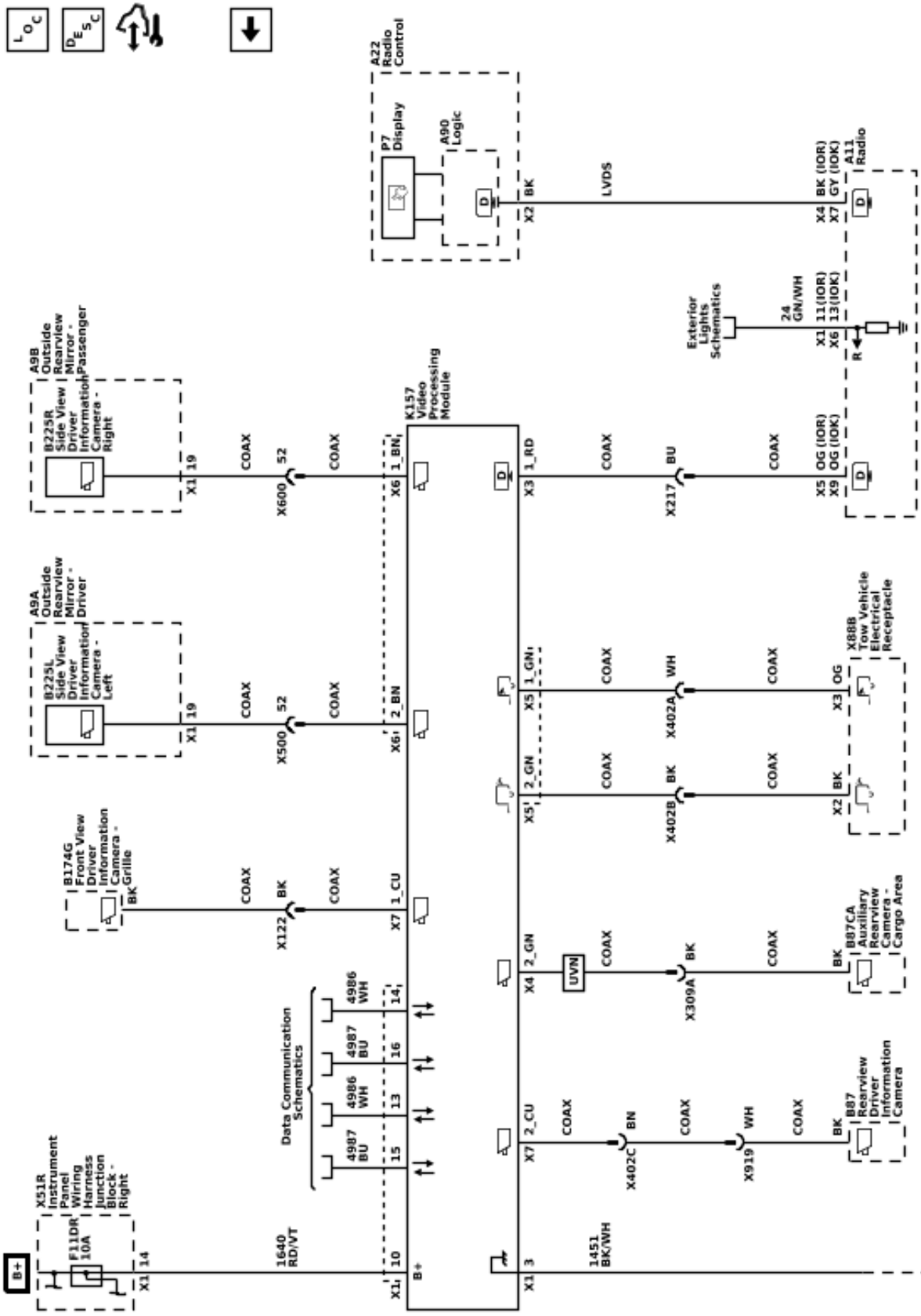

Image Display Camera Schematics (360 Degree Vision (UV2))



G300A

## Description and Operation

### Rearview Camera Full Display Mirror Description and Operation

If equipped, full display mirror provides a wider field of view than normally seen from the inside rearview mirror to assist when driving and changing lanes. When the tab under the inside rearview mirror is pulled rearward, a view of the area behind the vehicle displays on the mirror. The inside rearview camera full display mirror is connected to the outside rearview camera via a shielded coaxial cable.

When the tab under the inside rearview mirror is pulled rearward, a view of the area behind the vehicle displays on the mirror.

Adjust the rearview mirror for a clear view of the area behind the vehicle before turning on full display mirror. Use the three buttons on the bottom of the mirror to adjust the brightness, zoom, and tilt of the display. Make sure the light sensor is not covered when adjusting the brightness.

The inside rearview camera full display mirror may not work properly or display a clear image if:

- It is dark.
- The sun or the beam of headlamps are shining directly into the camera lens.
- Ice, snow, mud, or anything else builds up on the camera lens. Clean the lens, rinse it with water, and wipe it with a soft cloth.

When the mirror detects that the camera is not sending a valid video signal, it “blue screens” with a “no video” decal for 3 seconds, then reverts back to the mirror.

## Rear Vision Camera Description and Operation

### Rear Vision Camera System Operation

The rear vision camera system consists of a video camera located at the rear of the vehicle and the Radio.

When the transmission is placed into REVERSE, a signal is sent to the Radio indicating that camera operation is requested. The rearview camera sends video information to the radio through a coax cable. The coax cable also provides power from the Radio to the rearview camera.

The following conditions may cause a degraded rear vision camera image:

- Ice, snow, or mud has built up on the rear vision camera
- Dark conditions
- Extreme light conditions, such as glare from the sun or the headlights of another vehicle
- Damage to the rear of the vehicle
- Extreme high temperatures or extreme temperature changes

If a malfunction is detected in the system, Service Rear Vision Camera may be displayed on the Info Display Module as an indicator to the customer that a problem exists that requires service.

## Surround Vision Camera Description and Operation

**Warning:** The Surround Vision cameras have blind spots and will not display all objects near the corners of the vehicle. Folding outside mirrors that are out of position may not display surround view correctly. Always check around the vehicle when parking or backing.

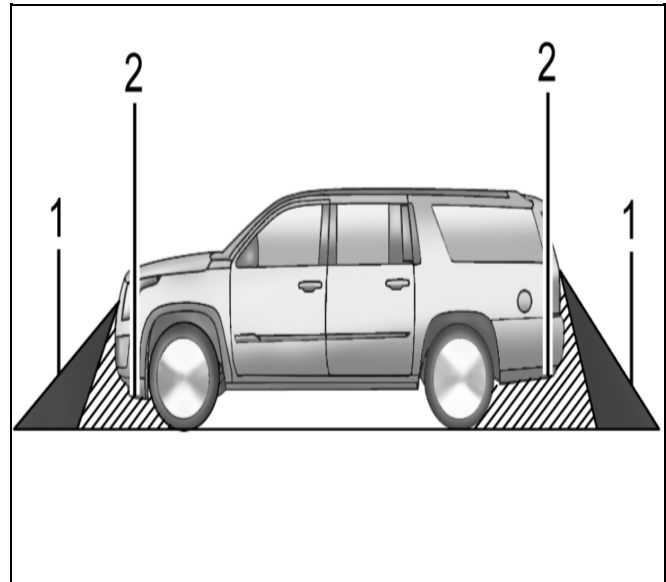

4291164

1. View Displayed by the Surround Vision Camera
2. Area Not Shown

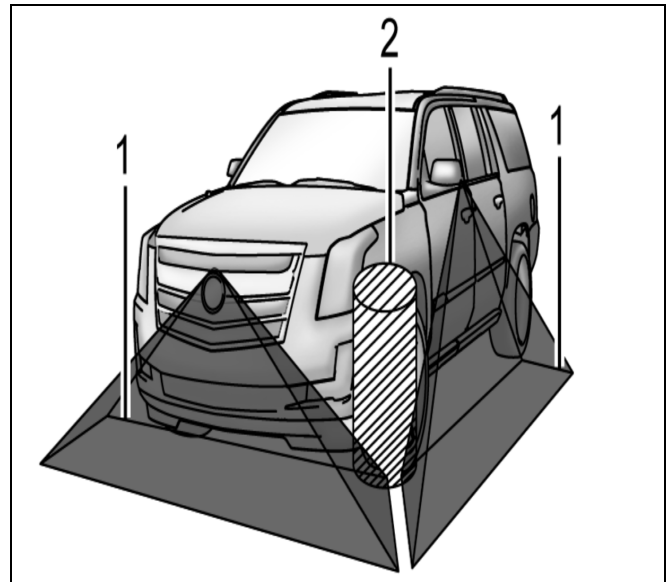

4291749

1. View Displayed by the Surround Vision Camera
2. Area Not Shown

The surround vision camera system consists of the following components:

- B87 Rearview Camera
- B174G Frontview Camera – Grille
- K157 Video Processing Control Module

## 3-8 Image Display Cameras

---

- A11 Radio **OR** K74 Human Machine Interface Module
- B225L Sideview Camera – Left
- B225R Sideview Camera – Right
- X20 Memory Card Receptacle (with XVR)

When the vehicle is traveling at speeds slower than 6 mph (10kph) the video processing control module will power up the cameras and send a video signal to the radio or human machine interface module.

The following conditions may cause a degraded surround vision camera image:

- Ice, snow, or mud has built up on the rear vision camera
- Dark conditions
- Extreme light conditions, such as glare from the sun or the headlights of another vehicle
- Damage to the rear of the vehicle
- Extreme high temperatures or extreme temperature changes

Surround Vision displays an overhead view of the area surrounding the vehicle, along with the front or rear camera views in the center stack. The front camera is in the grille or near the front emblem, the side cameras are on the bottom of the outside rearview mirrors, and the rear vision camera is above the license plate.

**Note:** Images from the Sideview Cameras are only displayed when both front doors are properly closed.

### Features of the Surround Vision System

- Rear camera (B87 Rearview Camera) view alongside overhead view is displayed in reverse
- Front camera (B174G Frontview Camera – Grille) view alongside overhead view is displayed after shifting out of reverse to Neutral or Drive
- Will display front view when front park assist object is within trigger range calibration value (30 cm (12 in) in a forward gear
- Image is removed from display when vehicle speed exceeds speed calibration (10kph/6 mph) or button press / screen touch

### System Operation

The video processing control module is connected to each camera via a shielded coaxial cable. The coaxial cable provides power for the camera and also carries the video image from the cameras to the video processing control module for processing. The video processing control module will then send the processed image output to infotainment system via another coaxial cable.

The video processing module receives various vehicle information (such as steering wheel angle, object detection, etc) from other sources such as parking assist modules and the Body Control Module via serial data. This information is used to produce the enhanced surround vision system images that include a warning triangle that may display if an object is detected nearby. This triangle changes from amber to red and increases in size as the object gets closer to the vehicle. Also, dynamic guidelines are displayed in Reverse to show the projected path of the vehicle based on steering

wheel angle. Due to this use of vehicle information, any faults or DTCs in these related systems can prohibit proper surround vision operation.

If equipped, the video processing control module system may have a memory card receptacle (with XVR) located in the trunk. The memory card receptacle interfaces with the video processing control module via a USB cable. The memory card receptacle also receives fused battery voltage and ground from the video processing control module. The video processing control module uses the memory card as a mass storage device, similar to a USB storage device.

## Section 4

# Engine/Propulsion

### Starting, Charging, and Low Voltage Energy

<b>Storage</b> .....	<a href="#">4-3</a>
<b>Schematic and Routing Diagrams</b> .....	<a href="#">4-3</a>
Starting and Charging Schematics .....	<a href="#">4-4</a>
<b>Description and Operation</b> .....	<a href="#">4-9</a>
Battery Description and Operation .....	<a href="#">4-9</a>
Charging System Description and Operation ....	<a href="#">4-9</a>
Electrical Power Management Description and Operation .....	<a href="#">4-12</a>
Starting System Description and Operation ....	<a href="#">4-14</a>
Stop/Start System Description and Operation .....	<a href="#">4-15</a>

**BLANK**



# Starting, Charging, and Low Voltage Energy Storage

## Schematic and Routing Diagrams

Starting and Charging Schematics (Starting (L3B / L84 / L87))

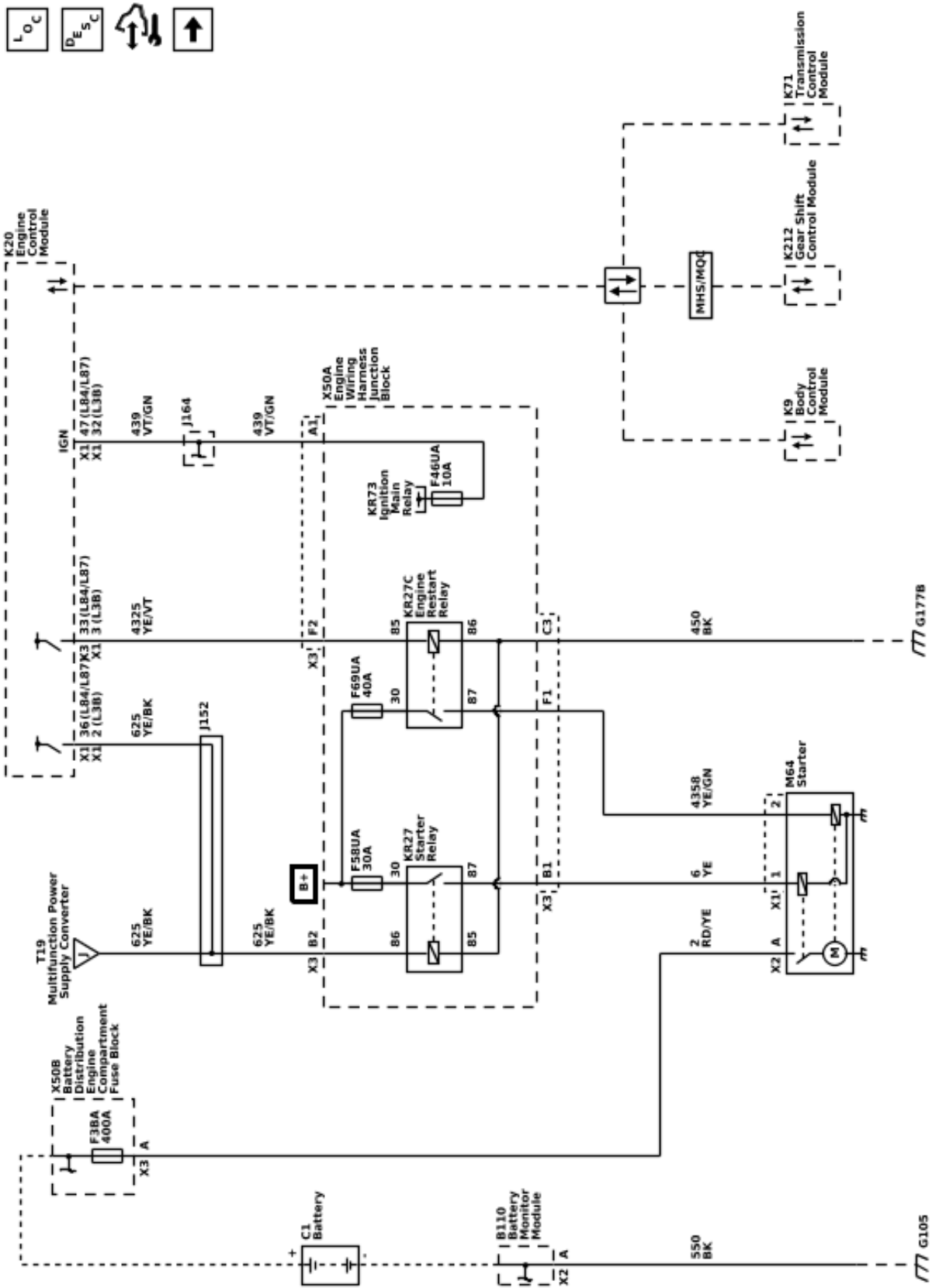

6278633

Starting and Charging Schematics (Starting (LZ0))

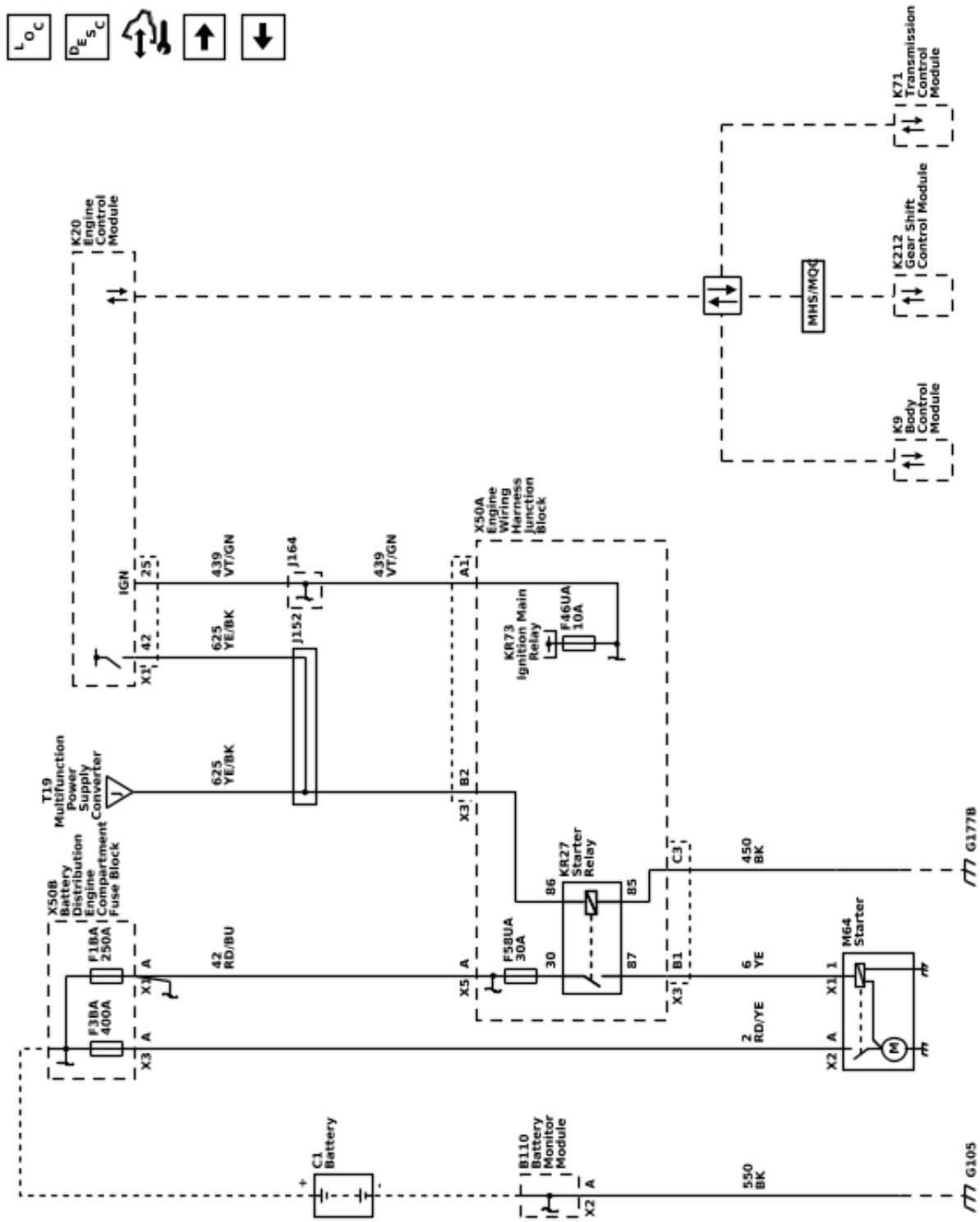

Starting and Charging Schematics (Charging)

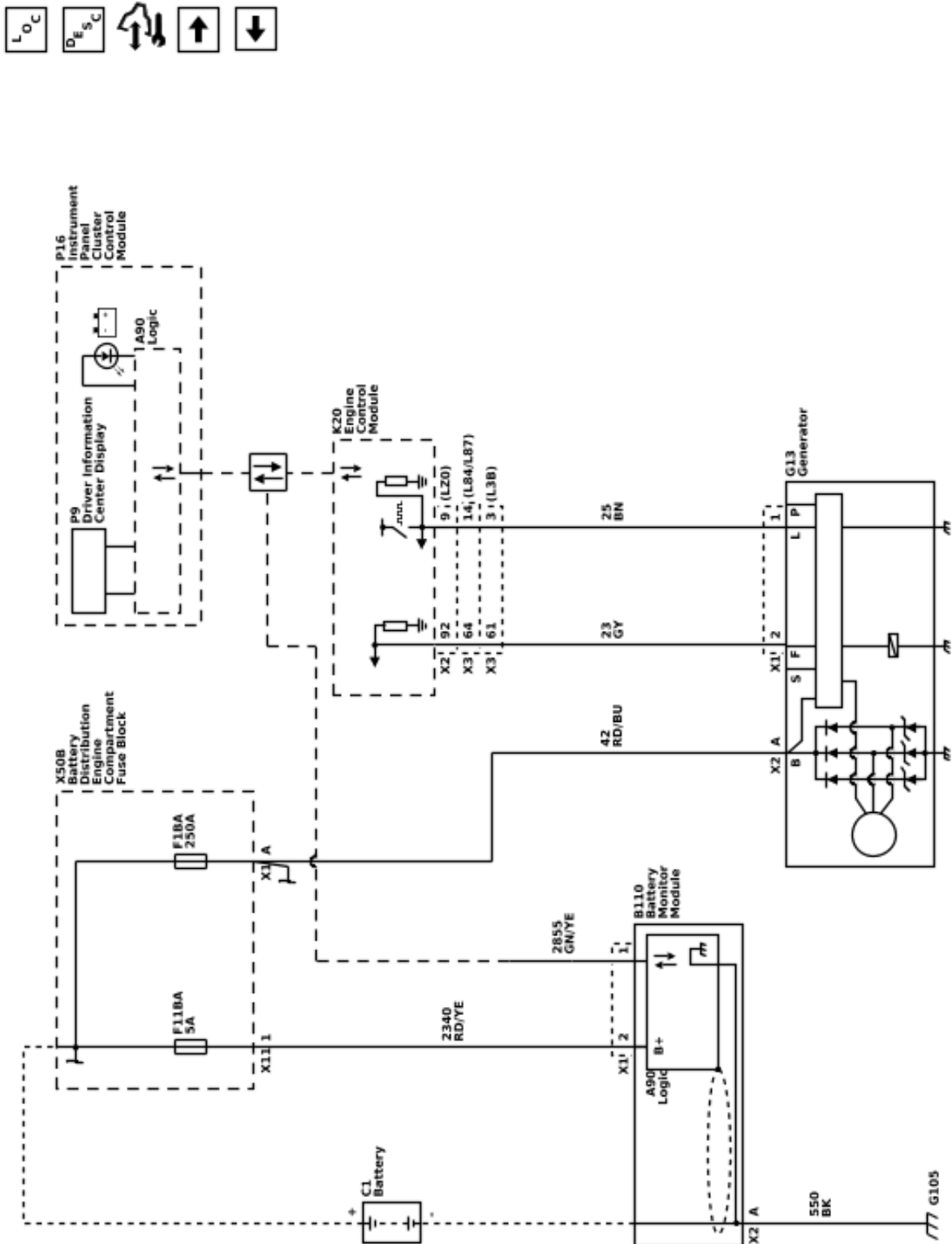

Starting and Charging Schematics (Power Supply Transformer Power, Ground, Serial Data, and Subsystem References (KL9))

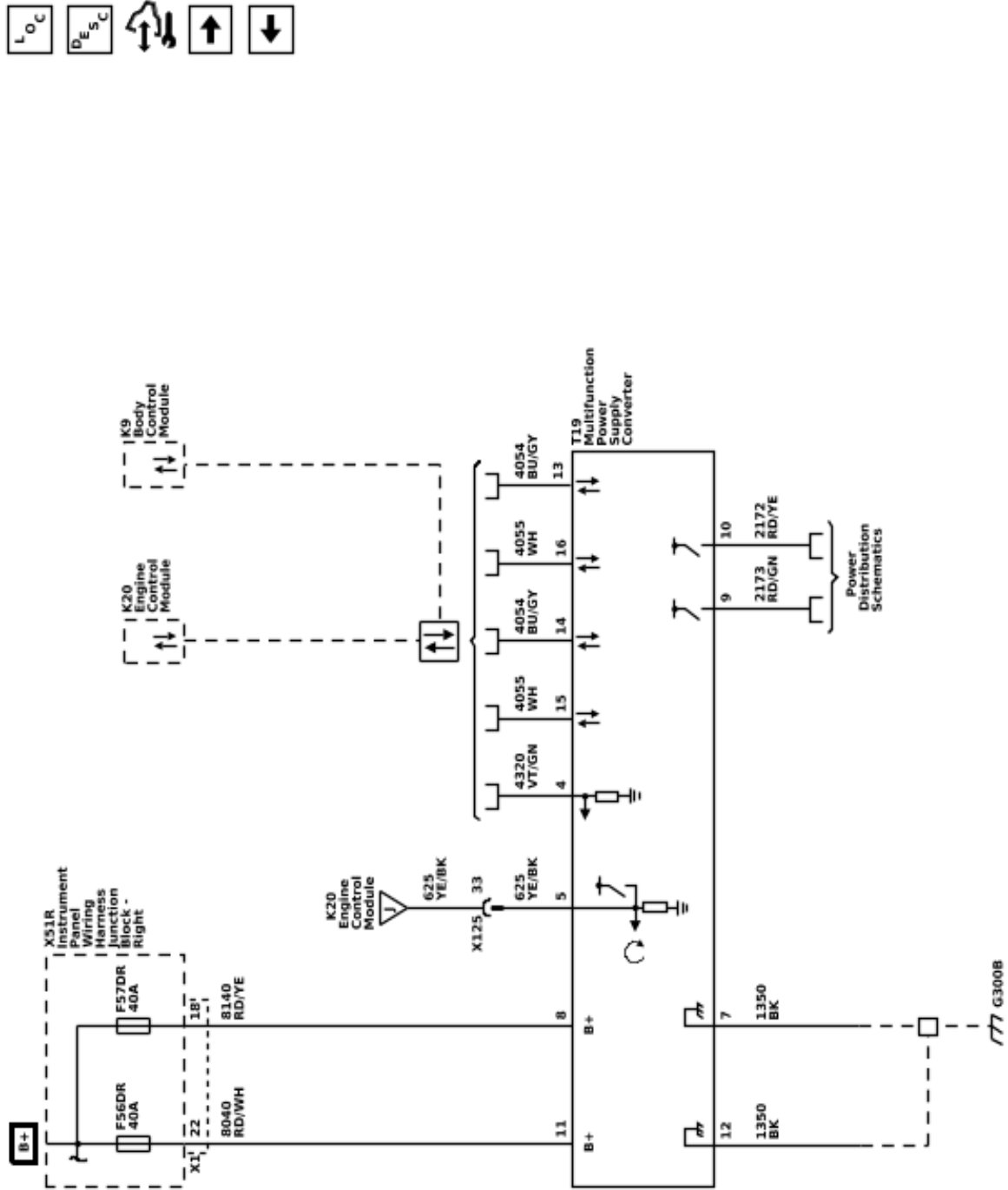

Starting and Charging Schematics (Stop/Start Controls (KL9))

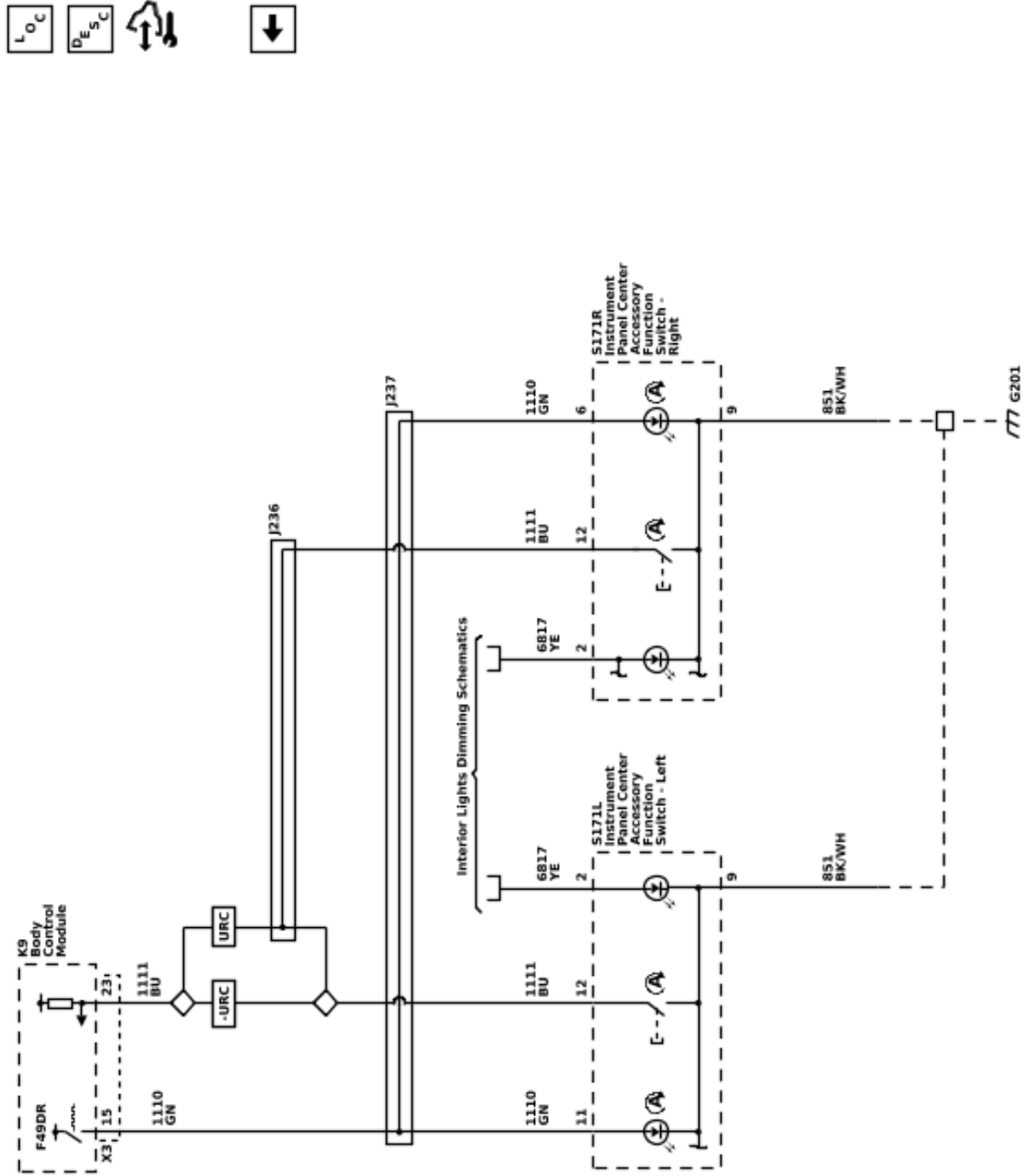

## Description and Operation

### Battery Description and Operation

**Warning:** Batteries produce explosive gases, contain corrosive acid, and supply levels of electrical current high enough to cause burns. Therefore, to reduce the risk of personal injury when working near a battery:

- Always shield your eyes and avoid leaning over the battery whenever possible.
- Do not expose the battery to open flames or sparks.
- Do not allow the battery electrolyte to contact the eyes or the skin. Flush immediately and thoroughly any contacted areas with water and get medical help.
- Follow each step of the jump starting procedure in order.
- Treat both the booster and the discharged batteries carefully when using the jumper cables.

Batteries that are no longer wanted must be disposed of by an approved battery recycler and must never be thrown in the trash or sent to a landfill.

Batteries that are not part of the vehicle itself, not the battery under the hood, must only be transported on public streets for business purposes via approved hazardous material transportation procedures.

Battery storage, charging and testing facilities in repair shops must meet various requirements for ventilation, safety equipment, material segregation, etc.

The maintenance free battery is standard. There are no vent plugs in the cover. The battery is completely sealed except for 2 small vent holes in the side. These vent holes allow the small amount of gas that is produced in the battery to escape.

The battery has 3 functions as a major source of energy:

- Engine cranking
- Voltage stabilizer
- Alternate source of energy with generator overload

### Battery Low Start Vehicle Message

The body control module (BCM) monitors battery positive voltage to determine battery state of charge. If one or more of the BCM battery positive voltage terminals measure less than approximately 11.6V compared to the BCM ground circuits, this message will display and four chimes may sound. Start the vehicle immediately. If the vehicle is not started and the battery continues to discharge, the climate controls, heated seats, and audio systems will shut off and the vehicle may require a jump start. These systems will function again after the vehicle is started.

### Battery Ratings

A battery has 2 ratings:

- Cold cranking amperage
- Amperage hours

When a battery is replaced use a battery with similar ratings. See battery specification label on the original battery.

### Amperage Hours

The amperage hour rating tells you how much amperage is available when discharged evenly over a 20 hour period. The amperage hour rating is cumulative, so in order to know how many constant amperage the battery will output for 20 h, you have to divide the amperage hour rating by 20. Example: If a battery has an amperage hour rating of 74, dividing by 20 = 3.75. Such a battery can carry a 3.75 A load for 20 hours before dropping to 10.5 V. (10.5 V is the fully discharged level, at which point the battery needs to be recharged.) A battery with an amperage hour rating of 55 will carry a 2.75 A load for 20 hours before dropping to 10.5 V.

### Cold Cranking Amperage

The cold cranking amperage is an indication of the ability of the battery to crank the engine at cold temperatures. The cold cranking amperage rating is the minimum amperage the battery must maintain for 30 seconds at  $-18^{\circ}\text{C}$  ( $0^{\circ}\text{F}$ ) while maintaining at least 7.2 V. See battery label for the cold cranking amperage rating of this battery.

## Charging System Description and Operation

### Electrical Power Management Overview

The electrical power management system is designed to monitor and control the charging system and send diagnostic messages to alert the driver of possible problems with the battery and generator. This electrical power management system primarily utilizes existing on-board computer capability to maximize the effectiveness of the generator, to manage the load, improve battery state-of-charge and life, and minimize the system's impact on fuel economy. The electrical power management system performs 3 functions:

- Monitor the battery voltage and estimate the battery condition
- Take corrective actions by boosting idle speeds, and adjusting the regulated voltage
- Perform diagnostics and driver notification

The battery condition is estimated during ignition/vehicle off and during ignition/vehicle on. During ignition/vehicle off the state-of-charge of the battery is determined by measuring the open-circuit voltage. The state-of-charge is a function of the acid concentration and the internal resistance of the battery, and is estimated by reading the battery open circuit voltage when the battery has been at rest for several hours.

Any time the ignition/vehicle is on, the vehicle algorithm continuously estimates battery state-of-charge based on adjusted net amp hours, battery capacity, initial state-of-charge, and calculated temperature.

While the engine is running, the battery degree of discharge is primarily determined by the integrated battery current sensor, to obtain net amp hours.

## 4-10 Starting, Charging, and Low Voltage Energy Storage

In addition, the electrical power management function is designed to perform regulated voltage control to improve battery state-of-charge, battery life, and fuel economy. This is accomplished by using knowledge of the battery state-of-charge and temperature to set the charging voltage to an optimum battery voltage level for recharging without detriment to battery life.

### Charging System Components

#### G13 Generator

The engine drive belt drives the generator. When the rotor is spun, it induces an alternating current (AC) into the stator windings. The AC voltage is then sent through a series of diodes for rectification. The rectified voltage has been converted into a direct current (DC) for use by the vehicle's electrical system to maintain electrical loads and the battery charge. The voltage regulator integral to the generator controls the output of the generator; it is not serviceable. The voltage regulator controls the amount of current provided to the rotor. If the generator has field control circuit fault, the generator defaults to an output voltage of 13.8 V.

The generator is serviced as a complete assembly. If there is a diagnosed fault in the generator, it must be replaced as an assembly.

#### Generator Pulley

The pulley drives the Generator via the engine drive belt. There are 2 types of pulleys:

1. Conventional solid Pulley which is bolted to the Generator stator shaft. This Pulley can be serviced separately.
2. One Way Clutch Pulley or Overrunning Alternator Decoupler Pulley allows the Generator to spin freely when the engine rapidly slows down on sudden deceleration. This part is not serviceable and the Generator needs to be replaced as an assembly.

#### K9 Body Control Module (BCM)

The K9 Body Control Module communicates with the K20 Engine Control Module and the instrument cluster for electrical power management operation. The BCM determines the output of the generator and sends the information to the ECM for control of the generator turn on signal circuit. It monitors the generator field duty cycle signal circuit information sent from the ECM for control of the generator. It monitors the battery current sensor, the battery positive voltage circuit, and estimates battery temperature to determine battery state of charge. The BCM also performs idle boost.

#### B110 Battery Monitor Module

The Battery Monitor Module communicates to the BCM via LIN. The BCM shares this information with the ECM. The purpose of the battery sensor module is to transmit battery information that the BCM/ECM can use to make decisions regarding stop/start, battery saver mode, and load shedding.

#### K20 Engine Control Module (ECM)

When the engine is running, the generator turn-on signal is sent to the generator from the ECM, turning on the regulator. The generator's voltage regulator controls current to the rotor, thereby controlling the output voltage. The rotor current is proportional to the electrical pulse width supplied by the regulator. When the engine is started, the regulator senses generator rotation by detecting AC voltage at the stator through an internal wire. Once the engine is running, the regulator varies the field current by controlling the pulse width. This regulates the generator output voltage for proper battery charging and electrical system operation. The generator field duty terminal is connected internally to the voltage regulator and externally to the ECM. When the voltage regulator detects a charging system problem, it grounds this circuit to signal the ECM that a problem exists. The ECM monitors the generator field duty cycle signal circuit, and receives control decisions based on information from the BCM.

#### P16 Instrument Cluster

As a means of displaying the charging system functions, some vehicles may be equipped with a voltmeter gauge on the instrument cluster and/or a system voltage display in the driver information center. These will indicate the current vehicle system voltage.

The instrument cluster also provides customer notification if there is a concern with the charging system. There are two means of notification: a charge indicator on the instrument cluster and/or a service system message displayed on the Driver Information Center (DIC) if equipped.

### Charging System Operation

The purpose of the charging system is to maintain the battery charge and vehicle loads. There are 6 modes of operation and they include:

- Battery Sulfation Mode
- Charge Mode
- Fuel Economy Mode
- Head lamp Mode
- Start Up Mode
- Voltage Reduction Mode

The ECM Controls the Generator through the generator turn-on signal circuit, also known as the Generator L-terminal. The ECM monitors the generator performance through the Generator field duty cycle signal circuit, also known as the generator F-terminal.

The Generator turn-on signal (Generator L-terminal) is a Pulse Width Modulation (PWM) signal of 128 Hz with a duty cycle of 0–100%. Normal duty cycle is between 5–95%. 0–5% and 95–100% are for diagnostic purposes, with 0–5% monitoring for an open circuit and 95–100% monitoring for a short to ground at a fixed 13.8 V. The following table shows the commanded duty cycle and output voltage of the Generator:



Commanded Duty Cycle	Generator Output Voltage (+/- .25 V)
0–5%	13.8 V
10%	11 V
20%	11.56 V
30%	12.13 V
40%	12.69 V
50%	13.25 V
60%	13.81 V
70%	14.38 V
80%	14.94 V
90%	15.5 V
95–100%	13.8 V

The Generator provides a PWM feedback signal of the Generator voltage output through the Generator field duty cycle signal circuit to the ECM. This information is sent to the Body Control Module (BCM). The Generator field duty cycle signal (Generator F-terminal) is a PWM signal of 60–460 Hz with a duty cycle of 0–100%. Normal duty cycle is between 5–100%. 0–5% is reserved for diagnostic purposes.

As the charging systems works to maintain the battery charge and manage vehicle electrical loads, it is normal for the voltmeter gauge on the instrument cluster or the system voltage displayed in the DIC to fluctuate or change. This does not indicate a malfunction. Depending on the battery state of charge and the vehicle electrical load, these values may be anywhere from 12.5 V to 15.5 V.

## Charging System Modes

### Battery Sulfation Mode

The BCM will enter this mode when the interpreted Generator output voltage is less than 13.2 V for 45 minutes. When this condition exists the BCM will enter Charge Mode for 2–3 minutes. The BCM will then determine which mode to enter depending on voltage requirements.

### Charge Mode

The BCM will enter Charge Mode when ever one of the following conditions are met:

- Windshield wipers are ON for more than 3 s.
- Climate Control Voltage Boost Mode Request is true, as sensed by the HVAC control module via serial data. High speed cooling fan, rear defogger, and HVAC high speed blower operation can cause the BCM to enter the Charge Mode.
- The estimated battery temperature is less than 0° C (32°F).
- Battery State of Charge is less than 80%.
- Vehicle speed is greater than 145 km/h (90 mph)
- A current sensor malfunction exists.
- System voltage is determined to be below 12.56 V

When any one of these conditions is met, the system will set targeted generator output voltage to a charging voltage between 13.9–15.5 V, depending on the battery state of charge and estimated battery temperature.

### Fuel Economy Mode

The BCM will enter Fuel Economy Mode when the estimated battery temperature is at least 0°C (32°F) but less than or equal to 80°C (176°F), the calculated battery current is less than 15 A and greater than –8 A, and the battery state-of-charge is greater than or equal to 80%. Its targeted generator output voltage is the open circuit voltage of the battery and can be between 12.5–13.1 V. When fuel economy mode is active, the generator is not charging, only maintaining open circuit battery voltage. The BCM will exit this mode and enter Charge Mode when any of the conditions described above are present.

### Headlamp Mode

The BCM will enter Headlamp Mode when ever the head lamps are ON (high or low beams). Voltage will be regulated between 13.9–14.5 V.

### Start Up Mode

When the engine is started the BCM sets a targeted generator output voltage of 14.5 V for 30 s.

### Tow/Haul Mode (if applicable)

Pressing the Tow/Haul Mode button located on the center stack, the vehicle system voltage is raised and the remote (non-vehicle) battery will be charged. Having the headlamps on will raise the system voltage and if the Tow/Haul button is applied it will not serve any purpose. The voltage is regulated between 13.9-14.5 V.

## Instrument Cluster Operation

### Charge Indicator Operation

The instrument cluster illuminates the charge indicator and displays a warning message in the driver information center if equipped, when the one or more of the following occurs:

- The ECM detects that the generator output is less than 11 V or greater than 16 V. The instrument cluster receives a serial data message from the ECM requesting illumination.
- The instrument cluster determines that the system voltage is less than 11 V or greater than 16 V for more than 30 s. The instrument cluster receives a serial data message from the BCM indicating there is a system voltage range concern.
- The instrument cluster performs the displays test at the start of each ignition cycle. The indicator illuminates for approximately 3 s.

### Driver Information Center Message: BATTERY NOT CHARGING SERVICE CHARGING SYSTEM or SERVICE BATTERY CHARGING SYSTEM

The BCM and the ECM will send a serial data message to the driver information center for the BATTERY NOT CHARGING SERVICE CHARGING SYSTEM or SERVICE BATTERY CHARGING SYSTEM message to be displayed. It is displayed when a charging system DTC is a current DTC. The message is turned off when the conditions for clearing the DTC have been met.

## 4-12 Starting, Charging, and Low Voltage Energy Storage

### Voltmeter Gauge and/or System Voltage Display (if equipped)

As a means of displaying the charging system functions, some vehicles may be equipped with a voltmeter gauge on the instrument cluster and/or a system voltage display in the driver information center. These will indicate the current vehicle system voltage.

As the charging systems works to maintain the battery charge and manage vehicle electrical loads, it is normal for the voltmeter gauge on the instrument cluster or the system voltage display in the driver information center to fluctuate or change. This does not indicate a malfunction. Depending on the battery state of charge and the vehicle electrical load, these values may be anywhere from 12.5 V to 15.5 V.

## Electrical Power Management Description and Operation

### Electrical Power Management

The electrical power management is used to monitor and control the charging system and alert the driver of possible problems within the charging system. The electrical power management system makes the most efficient use of the generator output, improves the battery state-of-charge, extends battery life, and manages system electrical loads.

The load shed operation is a means of reducing electrical loads during a low voltage or low battery state-of-charge condition.

The idle boost operation is a means of improving generator performance during a low voltage or low battery state-of-charge condition.

Each electrical power management function, either idle boost or load shed, is activated in incremental steps. For example, idle boost 1 must be active before idle boost 2 can be active. The criteria used by the body control module (BCM) to regulate electrical power management are outlined below:

### Idle Boost and Load Shed With Current Sensor

Function	Battery Temperature Calculation	Battery Voltage Calculation	Amp-Hour Calculation	Action Taken
Idle Boost 1 Start	Less Than $-15^{\circ}\text{C}$ ( $5^{\circ}\text{F}$ )	Less Than 13 V	—	First level Idle boost requested
Idle Boost 1 Start	—	—	Battery has a net loss greater than 0.6 Ah	First level Idle boost requested
Idle Boost 1 Start	—	Less Than 11 V	—	First level Idle boost requested
Idle Boost 1 End	Greater Than $-10^{\circ}\text{C}$ ( $14^{\circ}\text{F}$ )	Greater Than 12 V	Battery has a net loss less than 0.2 Ah	First level Idle boost request cancelled
Idle Boost 2 Start	—	—	Battery has a net loss greater than 1.6 Ah	Second level Idle boost requested
Idle Boost 2 Start	—	Less Than 11 V	—	Second level Idle boost requested
Idle Boost 2 End	—	Greater Than 12 V	Battery has a net loss less than 0.8 Ah	Second level Idle boost request cancelled
Load Shed 1 Start	—	—	Battery has a net loss of 4 Ah	Rear Defrost, Heated Mirrors, Heated Seats, HVAC cycled OFF for 20% of their cycle

**Idle Boost and Load Shed With Current Sensor (cont'd)**

Function	Battery Temperature Calculation	Battery Voltage Calculation	Amp-Hour Calculation	Action Taken
Load Shed 1 Start	—	Less Than 11 V	—	Rear Defrost, Heated Mirrors, Heated Seats, HVAC cycled OFF for 20% of their cycle
Load Shed 1 End	—	Greater Than 12 V	Battery has a net loss of less than 2 Ah	Clear Load Shed 1
Idle Boost 3 Start	—	—	Battery has a net loss of 10 Ah	Third level Idle boost requested
Idle Boost 3 Start	—	Less Than 11 V	—	Third level Idle boost requested
Idle Boost 3 End	—	Greater Than 12 V	Battery has a net loss of less than 6.0 Ah	Third level Idle boost request cancelled
Load Shed 2 Start	—	—	Battery has a net loss greater than 12 Ah	Rear Defrost, Heated Mirrors, Heated Seats, HVAC cycled OFF for 50% of their cycle. The BATTERY SAVER ACTIVE message will be displayed on the DIC
Load Shed 2 Start	—	Less Than 11 V	—	Rear Defrost, Heated Mirrors, Heated Seats, HVAC cycled OFF for 50% of their cycle. The BATTERY SAVER ACTIVE message will be displayed on the DIC
Load Shed 2 End	—	Greater Than 12 V	Battery has a net loss of less than 8 Ah	Clear Load Shed 2
Load Shed 3 Start	—	Less Than 11.9 V	Battery has a net loss greater than 20 Ah	Rear Defrost, Heated Mirrors, Heated Seats, HVAC cycled OFF for 100% of their cycle. The BATTERY SAVER ACTIVE message will be displayed on the DIC
Load Shed 3 Start	—	Less Than 11 V	—	Rear Defrost, Heated Mirrors, Heated Seats, HVAC cycled OFF for 100% of their cycle. The BATTERY SAVER ACTIVE message will be displayed on the DIC
Load Shed 3 End	—	Greater Than 12.6 V	Battery has a net loss of less than 13 Ah	Clear Load Shed 3

**Idle Boost and Load Shed Without Current Sensor (based on battery voltage)**

Function	Battery Temperature Calculation	Battery Voltage Calculation	Action Taken
Idle Boost 1 Start	Less Than -15°C (5°F)	Less Than 13 V	First level Idle boost requested
Idle Boost 1 Start	—	Less Than 12.6 V	First level Idle boost requested
Idle Boost 1 End	Greater Than -15°C (5°F)	—	First level Idle boost request cancelled
Idle Boost 1 End	—	Greater Than 13 V	First level Idle boost request cancelled

**Idle Boost and Load Shed Without Current Sensor (based on battery voltage) (cont'd)**

Function	Battery Temperature Calculation	Battery Voltage Calculation	Action Taken
Idle Boost 2 Start	—	Less Than 12.4 V	Second level Idle boost requested
Idle Boost 2 End	—	Greater Than 12.5 V	Second level Idle boost request cancelled
Load Shed 1 Start	—	Less Than 12.3 V	Rear Defrost, Heated Mirrors, Heated Seats, HVAC cycled OFF for 20% of their cycle
Load Shed 1 End	—	Greater Than 12.4 V	Clear Load Shed 1
Idle Boost 3 Start	—	Less Than 10 V	Third level Idle boost requested
Idle Boost 3 End	—	Greater Than 12.3 V	Third level Idle boost request cancelled
Load Shed 2 Start	—	Less Than 12.1 V	Rear Defrost, Heated Mirrors, Heated Seats, HVAC cycled OFF for 50% of their cycle. The BATTERY SAVER ACTIVE message will be displayed on the DIC
Load Shed 2 End	—	Greater Than 12.2 V	Clear Load Shed 2
Load Shed 3 Start	—	Less Than 11.9 V	Rear Defrost, Heated Mirrors, Heated Seats, HVAC cycled OFF for 100% of their cycle. The BATTERY SAVER ACTIVE message will be displayed on the DIC
Load Shed 3 End	—	Greater Than 12.0 V	Clear Load Shed 3

**Starting System Description and Operation**

**Starter Motor Operation (Without KL9)**

The starter motors are non-repairable. They have pole pieces that are arranged around the armature. Both solenoid windings are energized. The pull-in winding circuit is completed to the ground through the starter motor. The windings work together magnetically to pull and hold in the plunger. The plunger moves the shift lever. This action causes the starter drive assembly to rotate on the armature shaft spline as it engages with the flywheel ring gear on the engine. Moving at the same time, the plunger also closes the solenoid switch contacts in the starter solenoid. Full battery voltage is applied directly to the starter motor and it cranks the engine.

As soon as the solenoid switch contacts close, current stops flowing through the pull-in winding because battery voltage is applied to both ends of the windings. The hold-in winding remains energized. Its magnetic field is strong enough to hold the plunger, shift lever, starter drive assembly, and solenoid switch contacts in place to continue cranking the engine. When the engine starts, pinion overrun protects the armature from excessive speed until the switch is opened.

When the crank signal is removed, the starter relay opens and battery voltage is removed from the starter solenoid S terminal. Current flows from the motor contacts through both windings to the ground at the end of the hold-in winding. However, the direction of the

current flow through the pull-in winding is now opposite the direction of the current flow when the winding was first energized.

The magnetic fields of the pull-in and hold-in windings now oppose one another. This action of the windings, along with the help of the return spring, causes the starter drive assembly to disengage and the solenoid switch contacts to open simultaneously. As soon as the contacts open, the starter circuit is turned off.

**Enhanced Starter Motor Operation (KL9)**

The Engine Stop/Start system in GM vehicles automatically turns off the engine when the vehicle comes to a stop under certain driving conditions, and can quickly restart the engine in about 0.3 seconds when commanded to do so.

In order to smoothly restart the engine as quickly as possible while managing the greater number of engine starts, the Stop/Start system uses an enhanced starter motor that operates differently from a conventional starter motor. It has a high performance electric motor and a stronger pinion engagement mechanism than a conventional starter. It also has independent control of the pinion and motor.

The enhanced starter motor continues using the typical pinion engagement mechanism with a starter solenoid that drives the pinion gear to engage or disengage the flywheel of the engine. When engaged, the starter motor can rotate the engine flywheel and, in turn, the crankshaft.



On the enhanced starter of a Stop/Start system the operation is done in two separate functions inside the solenoid, Starter Motor and Pinion Actuator. Each function controlled individually by the ECM. There are two separate relays to control the two separate parts of the enhanced solenoid:

- KR27 Starter Motor Relay
- KR27C Starter Pinion Actuator Relay

The two individually-controlled relays allow for smooth engagement of the pinion gear into the flywheel with minimum noise and wear.

When the vehicle is coming to a stop, just before the engine stops rotating (at approximately 50 RPM) during stop/start operation, the ECM energizes the Starter Pinion Solenoid Actuator Relay to easily push the pinion gear into the flywheel gear without gear clash. (Fig. 8) When the engine stops rotating during Stop/Start operation (Auto Stop mode), the starter pinion gear is fully engaged, ready for the starter motor to become energized to quickly start the engine again.

A secondary need for the starter pinion to be driven into the flywheel gear before the engine stops rotating is to address quickly changing demands on the engine. For example, when a driver is slowing nearly to a stop — and the Stop/Start system is preparing for Auto Stop mode — but suddenly decides to release the brake and accelerate

In this situation, the engine has already stopped rotating, or nearly so. A conventional starter cannot restart the engine until the engine has completely stopped. However, with the enhanced starter, the starter pinion gear is fully engaged and ready to begin rotating the engine even before it fully stops turning. Otherwise, the engine would actually have to stop rotating before the pinion can engage smoothly to begin a restart.

To prevent a lag in engine operation, the ECM uses predictive speed matching of the flywheel gear speed and the pinion gear speed to engage the pinion gear into the flywheel gear without gear clash before the engine fully stops. By predicting how long it takes the starter motor to spin up using an algorithm, the pinion gear speed can be matched to the flywheel gear speed. The result is an almost instant restart that is possible at extremely low engine speeds.

## Circuit Description

### Keyless Start

When the Ignition mode switch is placed in the crank position, a discrete signal is supplied to the body control module (BCM) notifying it that the ignition is in the crank position. The BCM then sends a serial data message to the engine control module (ECM) that crank has been requested. The ECM then verifies that the brake pedal is applied and for manual transmission the clutch is fully depressed or for automatic transmission is in Park/Neutral. If it is, the ECM then supplies 12 V to the control circuit of the starter relay. When this occurs, battery positive voltage is supplied through the switch side of the crank relay to the S terminal of the starter solenoid.

### Key Start

When the ignition switch is placed in the Start position, a discrete signal is supplied to the body control module (BCM) notifying it that the ignition is in the Start position. The BCM then sends a message to the engine control module (ECM) notifying it that CRANK has been requested. The ECM verifies that the transmission is in Park or Neutral. If it is, the ECM then supplies 12 V to the control circuit of the crank relay. When this occurs, battery positive voltage is supplied through the switch side of the crank relay to the S terminal of the starter solenoid.

## Stop/Start System Description and Operation

The Stop/Start System is used to improve fuel efficiency in stop/start driving. The vehicle automatically shuts down the engine in appropriate conditions at a traffic light, for example, resulting in zero tail pipe emissions and saving fuel which otherwise is used idling the engine when stationary. The engine instantly restarts when the driver is ready to move away.

As soon as the driver prepares to move away (by releasing the brake pedal and/or depressing the accelerator pedal), the engine will start; it only takes the system around 0.3 s to start the engine.

To support the increased number of engine starts, the starter motor is upgraded with a high performance electric motor and a stronger pinion engagement mechanism with reduced noise levels.

Along with the upgraded starter motor, advanced battery technology is required to ensure the vehicles battery can handle the frequent charge and discharge cycles common with stop/start operation. There is battery sensor module connected to the battery which continually monitors the battery charge and healthy state. The Engine Control Module (ECM) uses this information from the battery sensor module to determine if the battery charge and health is sufficient for an Stop/Start condition.

The Stop/Start system can reduce fuel consumption and carbon dioxide (CO<sub>2</sub>) emissions by up to 5% in mixed driving conditions. In an urban environment and in heavy traffic with frequent stops the savings may increase to as much as 10%.

There are also sophisticated controls in place to help ensure the Stop/Start System does not compromise the needs of either the driver or vehicle. For the engine to shutdown, the vehicle must be below 5 km/h (3 MPH), the selector lever in position D, and brake pedal depressed. To restart, the driver simply releases the brake pedal and the enhanced starter motor engages the engine. When the engine has been shut down by the Stop/Start System, a control indicator will be illuminated in the Driver Information Center (DIC). When the engine is restarted, the control indicator in the DIC extinguishes.

To ensure neither the needs of the driver or vehicle are compromised the engine will not shut down in the following circumstances:

- Ambient and coolant temperature correlation does not match specified values.
- Ambient temperature is less than  $-10^{\circ}\text{C}$  ( $14^{\circ}\text{F}$ )

## 4-16 Starting, Charging, and Low Voltage Energy Storage

- Battery temperature is less than 0°C (32°F) or greater than 55°C (131°F)
- Driver seat belt is not fastened and the drivers door is not fully closed (not applicable to vehicles in North America)
- HVAC system demand is high
- HVAC defrost has been selected
- Battery charge is low

Likewise the engine will automatically restart if:

- Driver door opened and driver seat belt unbuckled (not applicable to vehicles in North America)
- Engine hood opened
- Battery charge is low
- HVAC demand increases
- Vehicle speed increases
- Brake booster vacuum has been reduced
- Engine coolant temperature is greater than 125°C (257°F)
- Economy mode turned OFF by driver
- Autostop time exceeded 2 min

When the Stop/Start System has shut down the engine, and the ambient temperature is below 15°C (59°F), the ECM will activate the Stop/Start auxiliary relay which controls the electric engine coolant pump motor to continually circulate the engine coolant through the engine while the engine is off. This is to ensure the engine and passenger compartment temperature is maintained while off. Once the Stop/Start System has restarted the engine, the ECM will turn off the electric coolant pump motor, thus allowing the engines internal coolant pump to circulate the engine coolant. The Stop/Start System is automatically activated each time the ignition switch is turned on.

Through the climate control system, the vehicle can be cycled between off, comfort, and eco air conditioning modes (if equipped). In comfort mode, the priority for Stop/Start operation is on customer comfort. Depending on ambient temp, humidity, cabin temperature and cabin temperature setpoint, the least

amount of autostops occur in this mode. In eco mode, the priority is on fuel economy. There are more frequent autostops with some sacrificing of cabin temperature control. With the HVAC turned off, the maximum autostops occur since there will be no A/C compressor requests.

### Autostop Criteria

The ECM will send an Autostop state message to the body control module (BCM) and shut down the engine when all of the following criteria is met. The BCM will transmit the Autostop state message to the instrument cluster which will display the Autostop indicator in the tachometer display.

- Initial minimum vehicle speed during drive cycle must be 19 km/h (12 MPH) or greater. Subsequent autostop minimum speed may vary from 2-10 km/h (1-6 MPH), depending on vehicle
- Ambient and engine coolant temperature correlation meets specified values.
- Ambient and transmission fluid temperature correlation meets specified values.
- Hood switch status is closed
- Driver door status is closed
- Driver seat belt status is buckled
- Brake booster vacuum is greater than 45 kPa (7 PSI)
- Transmission gear selector is in the Drive position
- Vehicle speed is less than 5 km/h (3 MPH)
- Engine speed is below 1,500 RPM
- Engine coolant temperature is less than 120°C (248°F)
- Ambient temperature is greater than -10°C (14°F)
- No A/C compressor request from HVAC (A/C or Defrost modes)
- Battery voltage greater than 12 V
- Battery state of charge greater than 75% (changes with state of health)

**Autostop Enable Ambient and Engine Coolant Temperature Table**

Ambient Temperature	inimum Coolant Temperature	Autostop Enable
-10°C (14°F)	60°C (140°F)	Yes
0°C (32°F)	50°C (122°F)	Yes
6°C (43°F)	40°C (104°F)	Yes
12°C (54°F)	30°C (86°F)	Yes
20°C (68°F)	18°C (64°F)	Yes
30°C (86°F)	18°C (64°F)	Yes

### Autostart Criteria

The ECM will send an Autostart state message to the BCM. If all of the following conditions are true the ECM and BCM will restart the vehicle.

Driver Enabled Conditions that will engage Autostart:

- Driver removes pressure from the brake or depresses the accelerator pedal while the vehicle is in the forward Drive gear

System Enabled Conditions that will engage Autostart

**Note:** If one or more of the following conditions occur, the system will force the engine to restart.

- Brake booster vacuum is less than 40 kPa (6 PSI)
- A/C compressor request from HVAC (A/C or Defrost modes)
- Battery voltage less than 11 V,
- Battery state of charge is less than 73% (changes with state of health)

- Driver door status changes to open and driver seat belt status changes to unbuckled (not applicable to vehicles in North America)
- Hood switch status changes to open
- Autostop time exceeded 2 min

If the crank time exceeds 2 s, a manual ignition switch restart will be necessary.

## System Components

### Engine Control Module (ECM)

The ECM monitors the inputs from the Engine Coolant Temperature (ECT) sensor, Vehicle Speed Sensor (VSS), Battery Sensor Module, hood ajar switch, brake booster vacuum sensor, and engine speed to determine Autostart and Autostop conditions. The ECM also controls the auxiliary coolant pump motor (if equipped).

### Transmission Control Module (TCM)

The TCM monitors the inputs from the transmission neutral safety switch to determine the driver selected gear. This information is transmitted to the ECM via serial data to support the Auto Stop Start algorithm.

### Engine Coolant Temperature sensor (ECT)

The ECT sensor is used to determine engine operating temperature.

### Intake Air Temperature Sensor (IAT)

The ECM uses this sensor to monitor ambient air temperature. If too cold, the Autostop will not occur.

### Inside air temperature sensor

The HVAC control module monitors the passenger compartment temperature sensor to determine the temperature inside the passenger compartment. The HVAC control module sends this temperature reading to the ECM on the data communication circuit. The ECM uses this temperature values to determine if a restart is required based on the temperature inside the passenger compartment.

### Vehicle speed sensor

The vehicle speed sensor is used to determine vehicle speed. If vehicle speed is detected above a calculated value during an Autostop condition, the ECM will start the engine.

### Hood Ajar Switch

If the hood switch is in the open position, the vehicle will not Autostop. If the hood is opened during Autostop, the vehicle will automatically restart.

### Brake Booster Vacuum Sensor

The ECM monitors vacuum in order to ensure proper power assist for the brake pedal. If the ECM determines vacuum is too low, it will restart the engine.

### Brake Pedal Position Sensor (BPPS) & Accelerator Pedal Position Sensor (APP)

The ECM monitors both the brake pedal position sensor and the accelerator pedal position sensor to determine the level of activation for each. While the accelerator pedal is in its at rest position with no pressure applied by the operator, a partially depressed Brake pedal will cause the ECM to prepare the engine

for an Autostop event. When the vehicle is in an auto stop event and the status of the brake pedal position sensor changes from meeting the autostop criteria to not meeting this criteria the engine will be restarted provided all of the other conditions to allow an autostart are met. If the Accelerator pedal is moved from its at rest position the vehicle will also enter an auto start event if all other conditions to support an autostart event, except for the brake pedal position, are met.

### Transmission Gear Shift Position Switch

The transmission gear shift position switch is used to determine if the transmission is in the proper state to allow an auto stop/start event. The ECM will not allow Autostop until the brake is engaged, the transmission is in the forward gear position and then the vehicle slows to below the minimum speed required to allow and autostop while meeting all of the other minimum criteria to support an autostop event.

### Coolant Pump Motor

The ECM will turn on the auxiliary coolant pump motor during Autostop to maintain engine operating temperature and HVAC temperature. Once the engine is running, the ECM will turn off the coolant pump motor.

### Body Control Module (BCM)

The Body Control Module (BCM) monitors the Autostop Disable switch in order to enable or disable the system. It sends the appropriate messages to the ECM Via serial data to enable or disable the system.

### Battery Sensor Module

The Battery Sensor Module monitors the battery current load, state of health, and state of charge, the information is sent to the BCM Via LIN then to the ECM Via Serial Data. If the module detects high current load, the battery is in a poor state of health or a low charge condition, the ECM will not allow Autostop to occur.

### Autostop Disable Switch

The disable switch is an input to the BCM, it allows the customer to disable or re-enable the Autostop system. After the vehicle is turned off the Autostop system will turn back on the next time the vehicle is started.

### Power Supply Transformer

The DC to DC converter monitors battery voltage and will maintain operating voltage to the radio, instrument cluster and instrument panel displays. The DC to DC converter will provide a boosted voltage to sensitive loads during Autostart to ensure proper operation of the driver informational displays.

### Instrument Cluster

In order to differentiate between a normal engine shut down (engine speed 0 RPM) and when the engine has been shut down by the Stop/Start System, the tachometer needle will rest at the Autostop indicator icon (500 RPM point) indicating the engine has been shut down by the Stop/Start System. Once the engine is restarted, or the ECO button has disengaged Autostop, the tachometer will function normally.

**BLANK**



## Section 5

# HVAC

### Heating, Ventilation, and Air

<b>Conditioning</b> .....	<a href="#">5-3</a>
<b>Schematic and Routing Diagrams</b> .....	<a href="#">5-3</a>
HVAC Schematics .....	<a href="#">5-4</a>
HVAC Schematics .....	<a href="#">5-10</a>
<b>Description and Operation</b> .....	<a href="#">5-16</a>
Heating and Air Conditioning System	
Description and Operation .....	<a href="#">5-16</a>
<b>HVAC - Automatic</b> .....	<a href="#">5-17</a>
<b>Schematic and Routing Diagrams</b> .....	<a href="#">5-17</a>
HVAC Schematics .....	<a href="#">5-18</a>
<b>Description and Operation</b> .....	<a href="#">5-24</a>
Automatic HVAC Description and Operation .....	<a href="#">5-24</a>
<b>HVAC - Manual</b> .....	<a href="#">5-28</a>
<b>Schematic and Routing Diagrams</b> .....	<a href="#">5-28</a>
HVAC Schematics .....	<a href="#">5-29</a>
<b>Description and Operation</b> .....	<a href="#">5-35</a>
Manual HVAC Description and Operation .....	<a href="#">5-35</a>

**BLANK**

# Heating, Ventilation, and Air Conditioning

## Schematic and Routing Diagrams

HVAC Schematics (HVAC Controls)

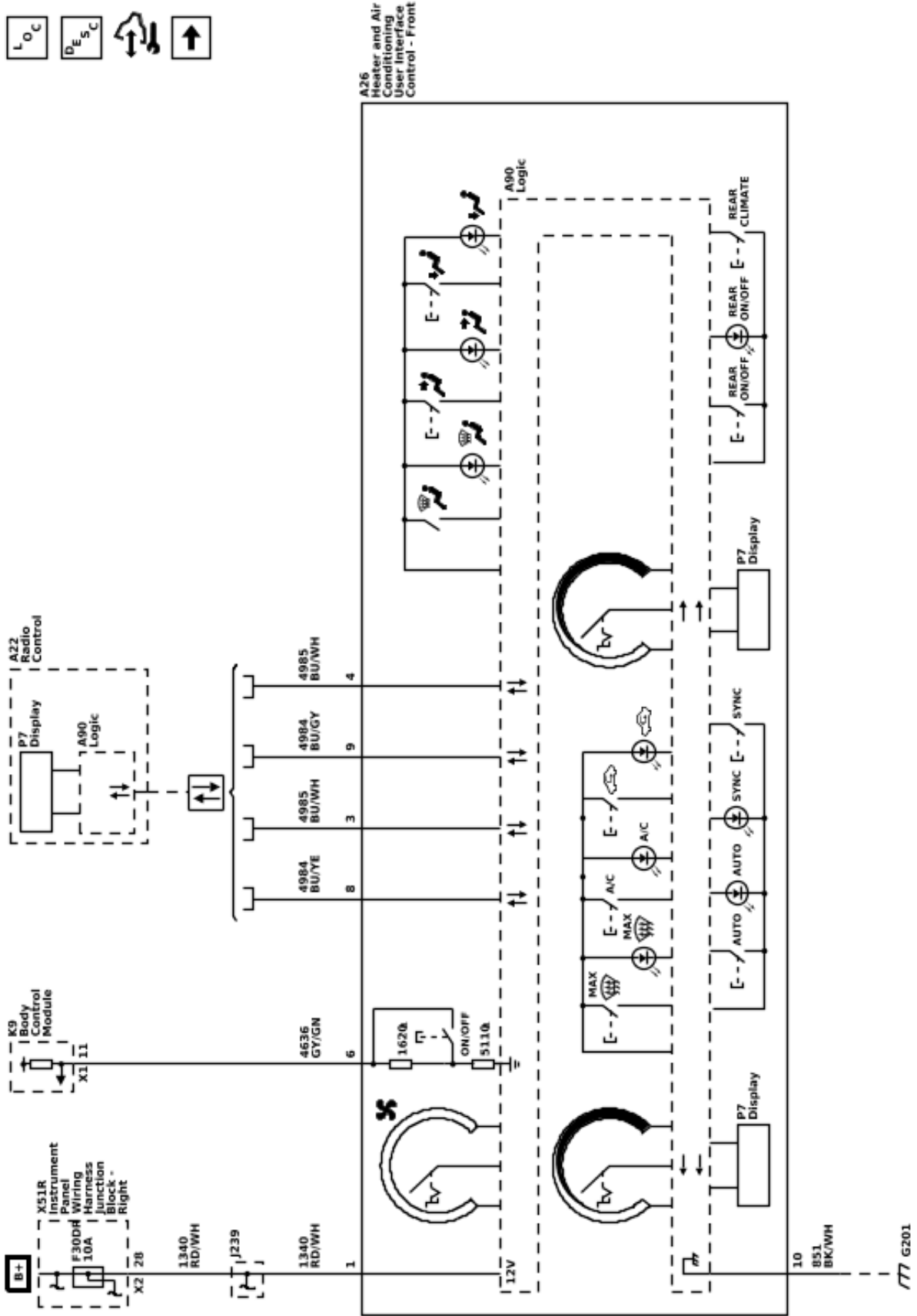
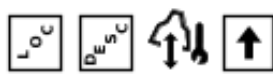

HVAC Schematics (Actuators)

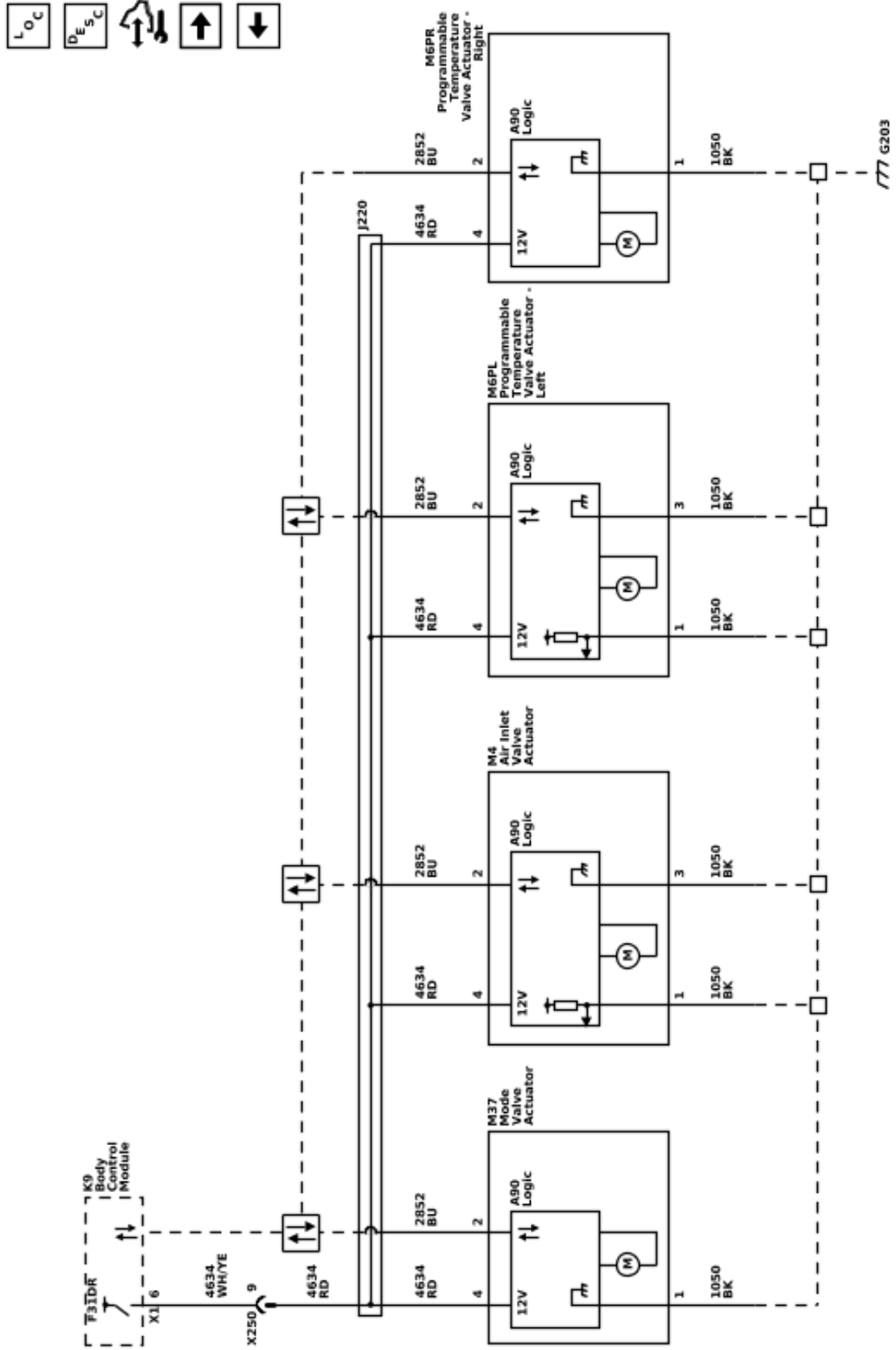

HVAC Schematics (Blower Motor)

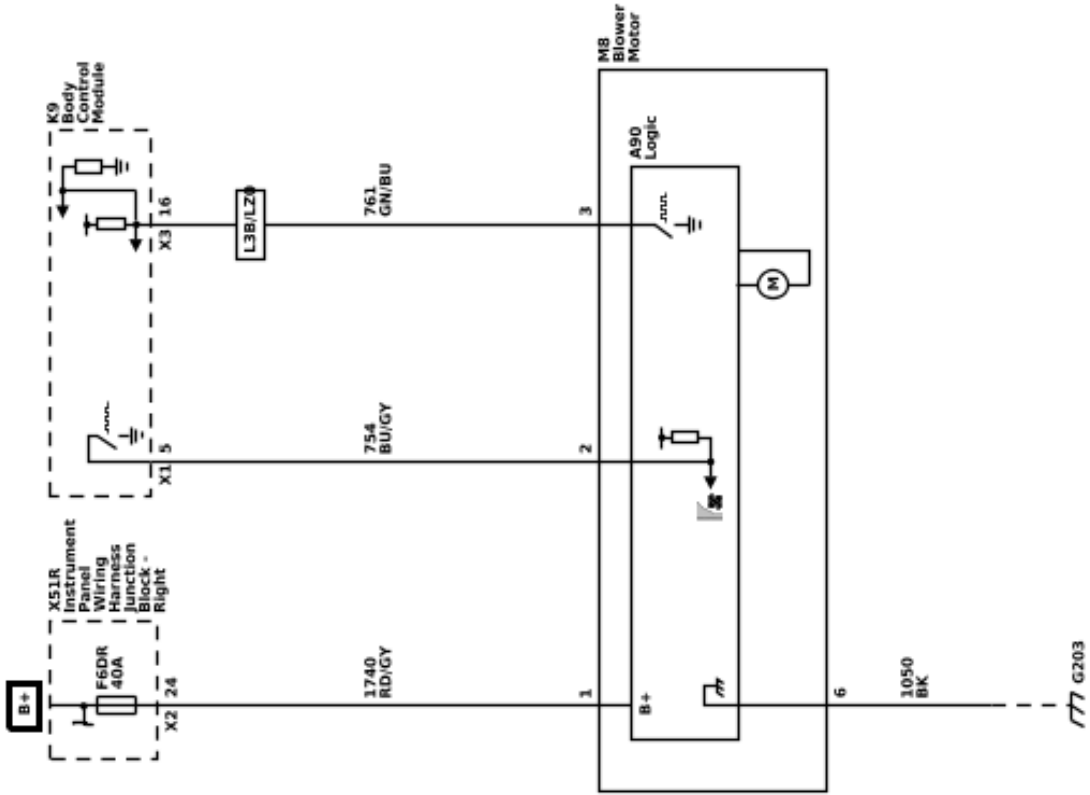

HVAC Schematics (Windshield Sensors and A/C Evaporator Temperature Sensor)

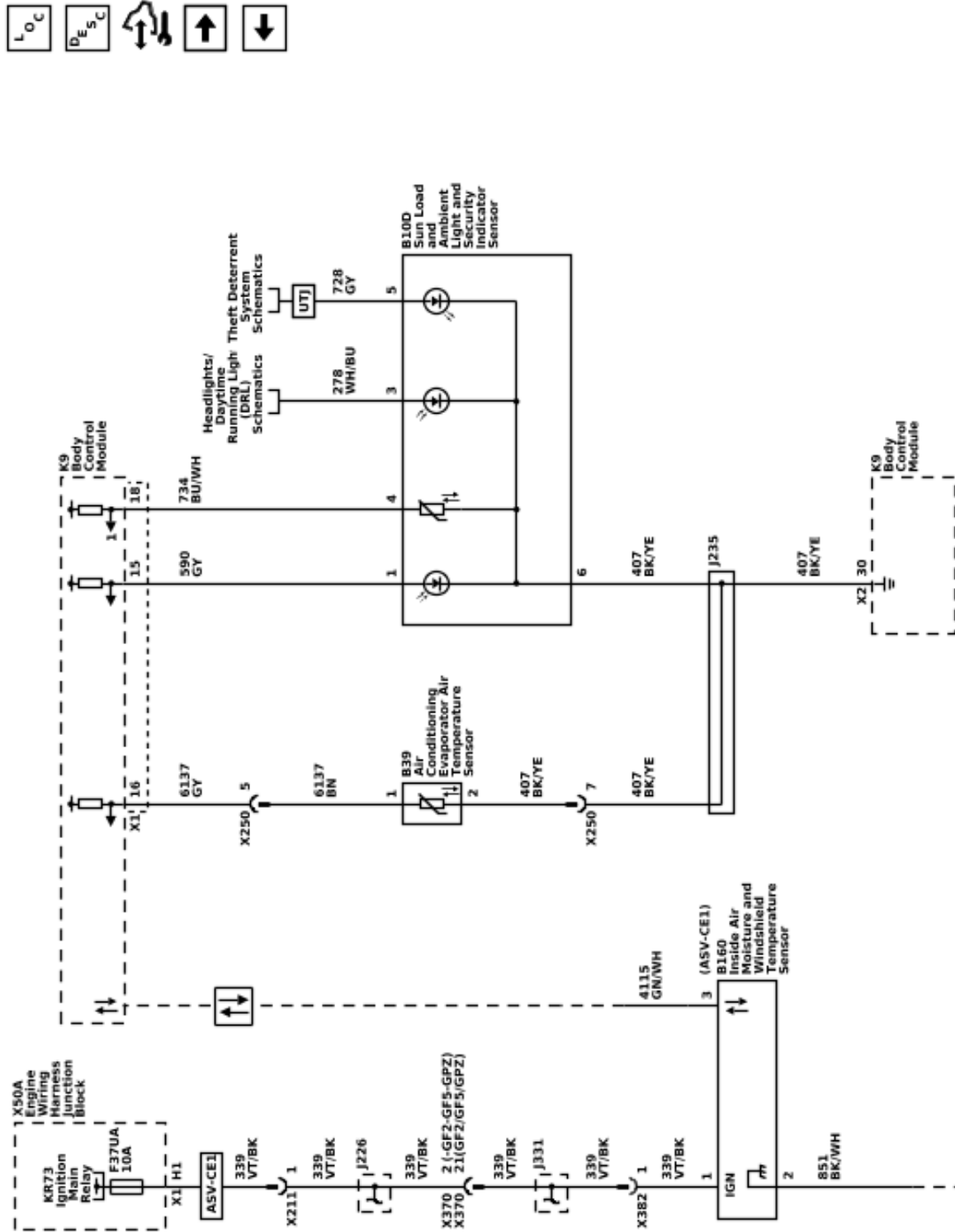

HVAC Schematics (A/C Compressor Controls)

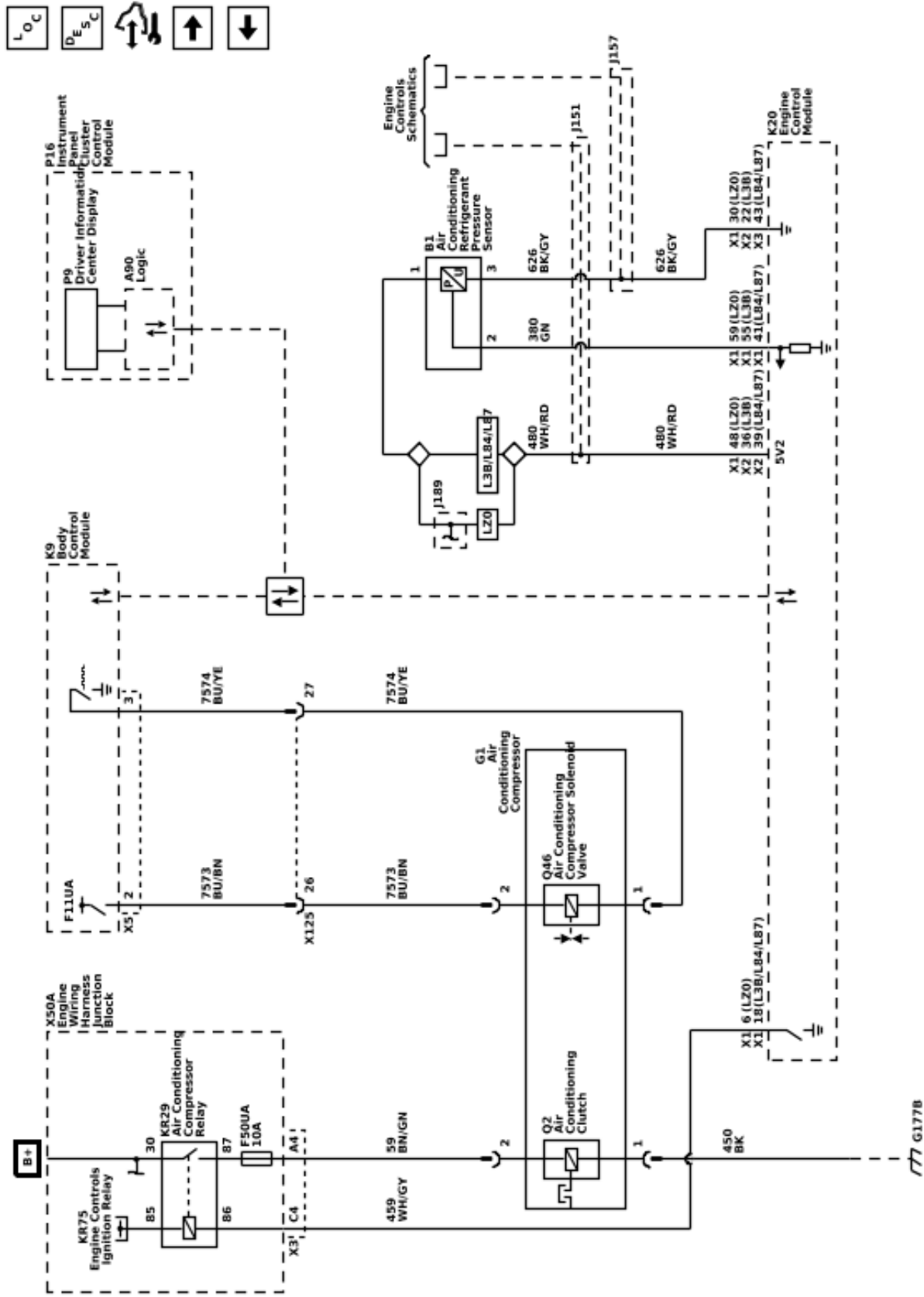



HVAC Schematics (Air Heater (C32))

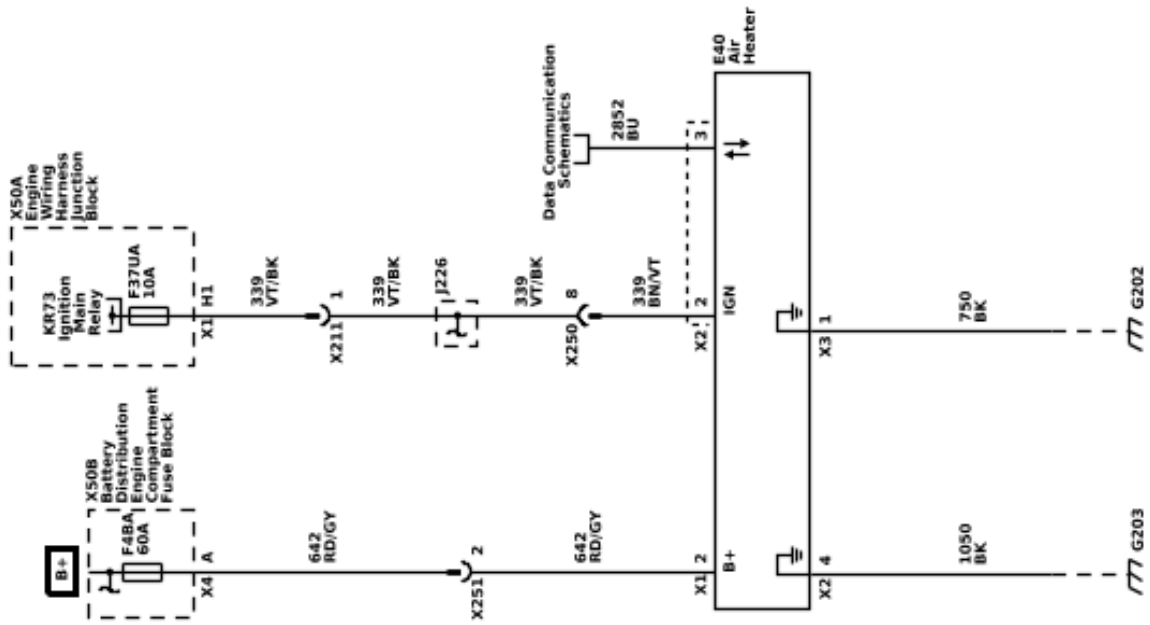

HVAC Schematics (HVAC Controls)

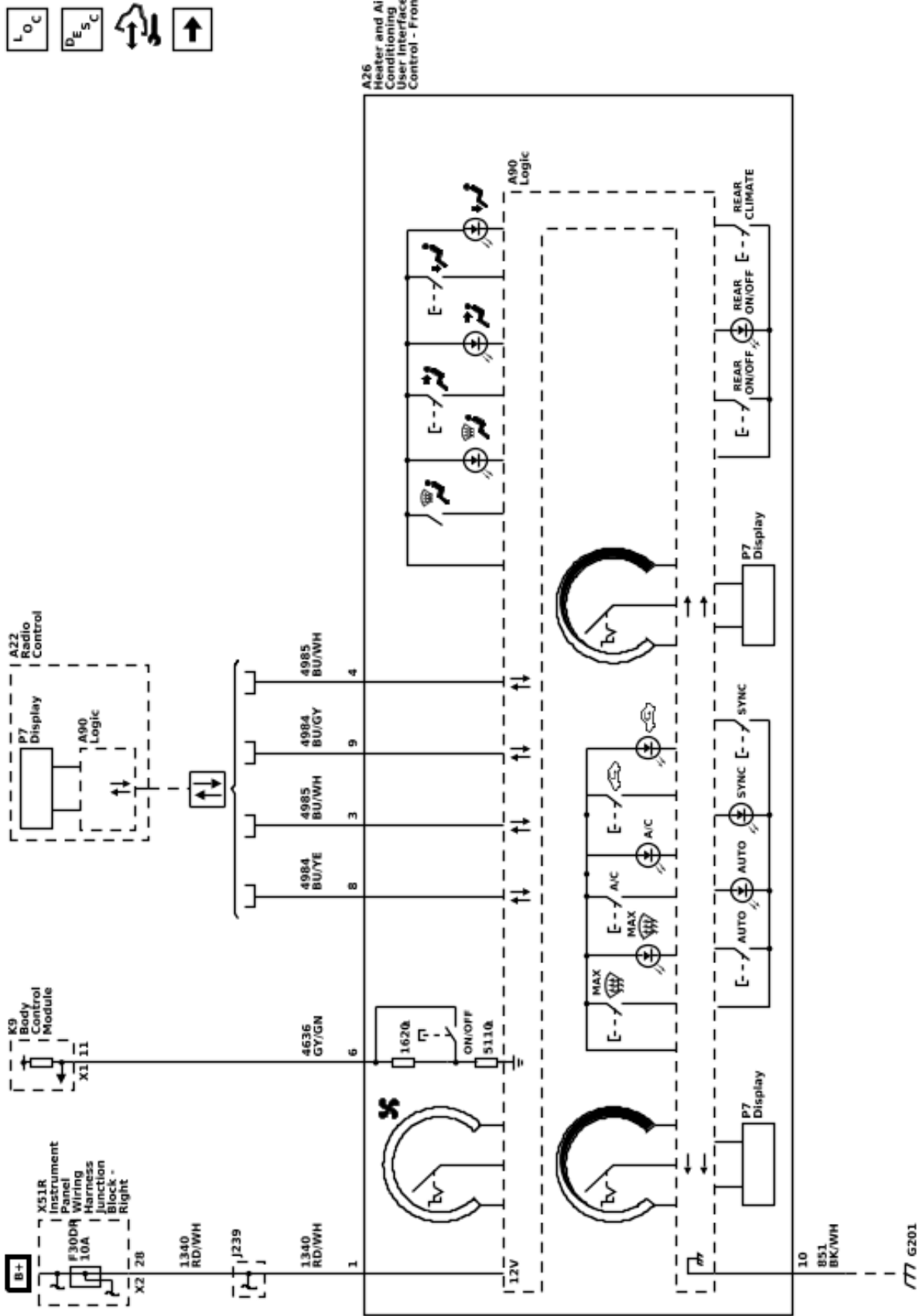
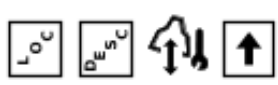

6278902

HVAC Schematics (Actuators)

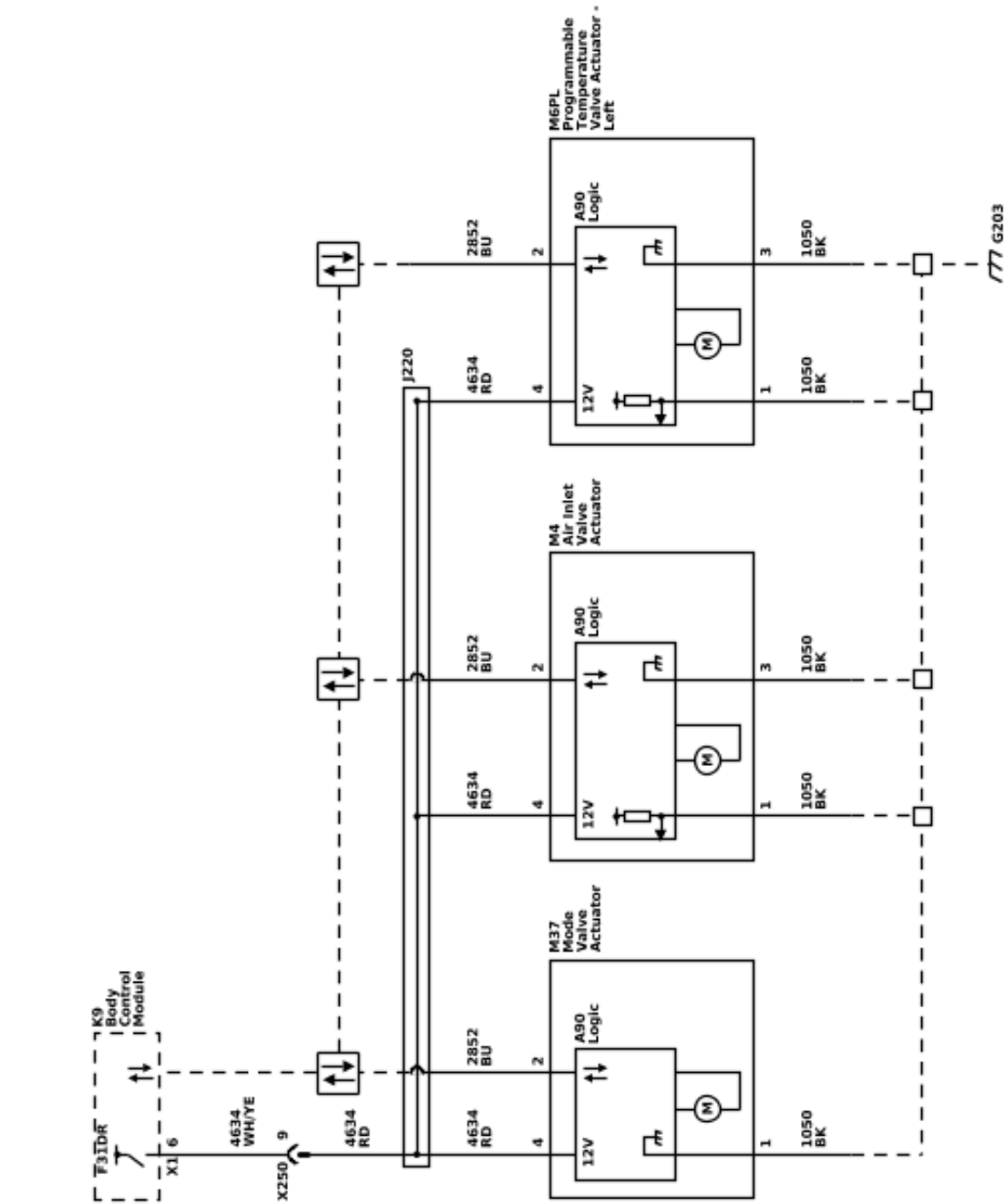

HVAC Schematics (Blower Motor)

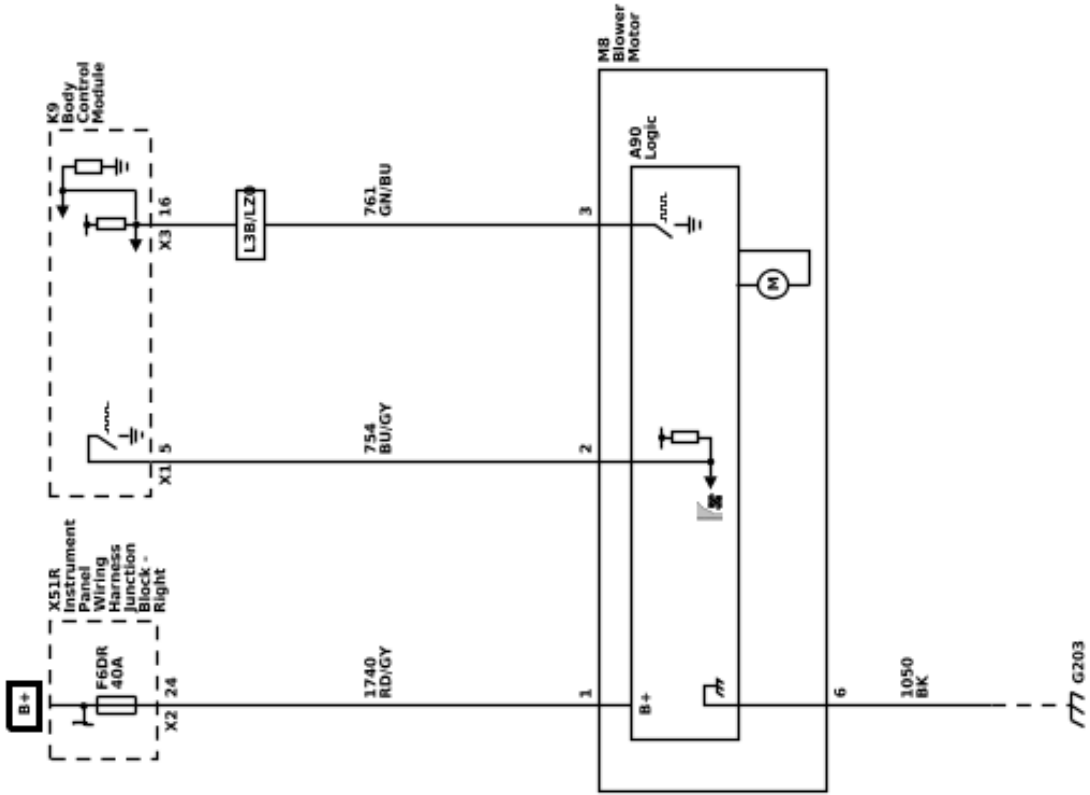

HVAC Schematics (Windshield Sensors and A/C Evaporator Temperature Sensor)

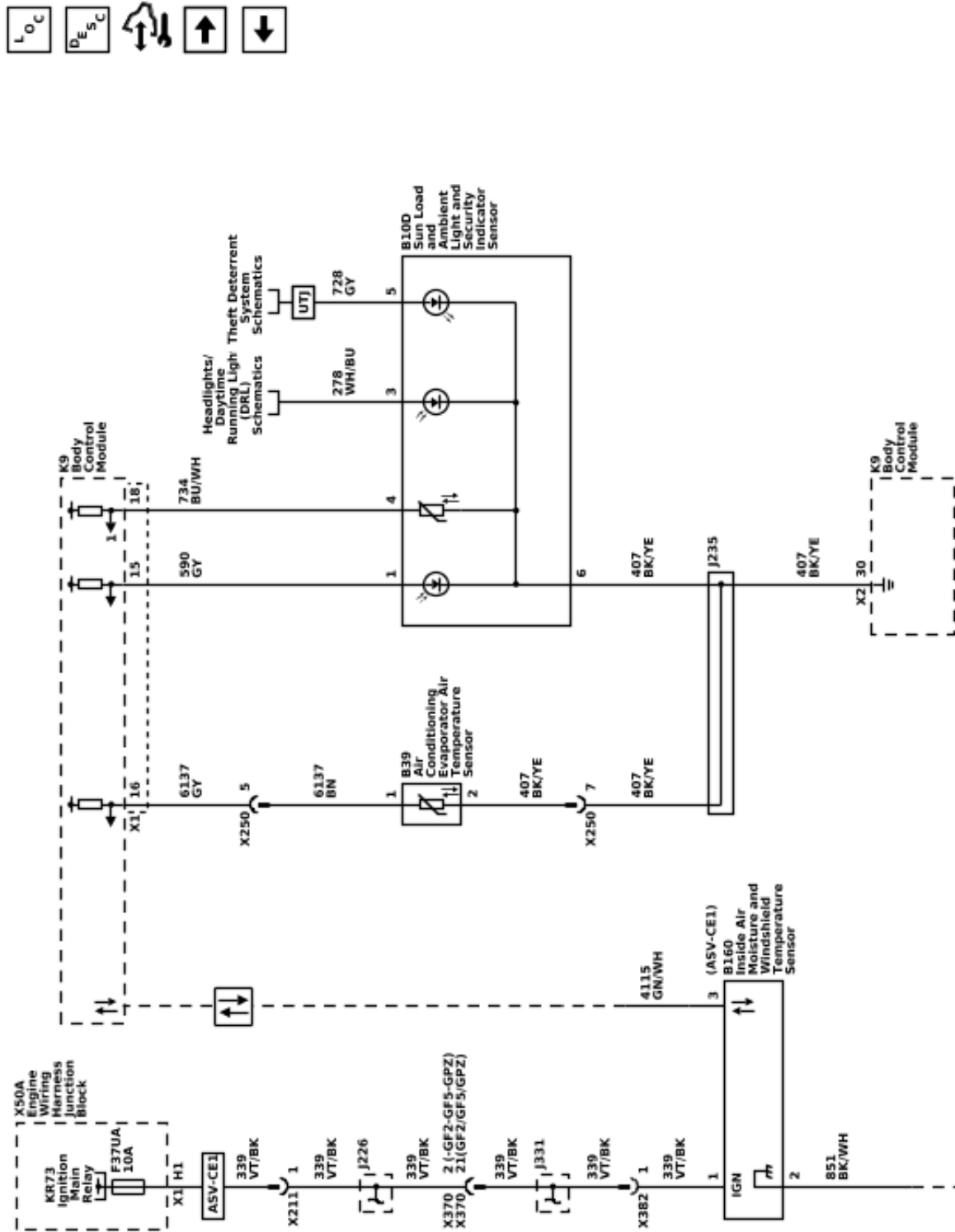

HVAC Schematics (A/C Compressor Controls)

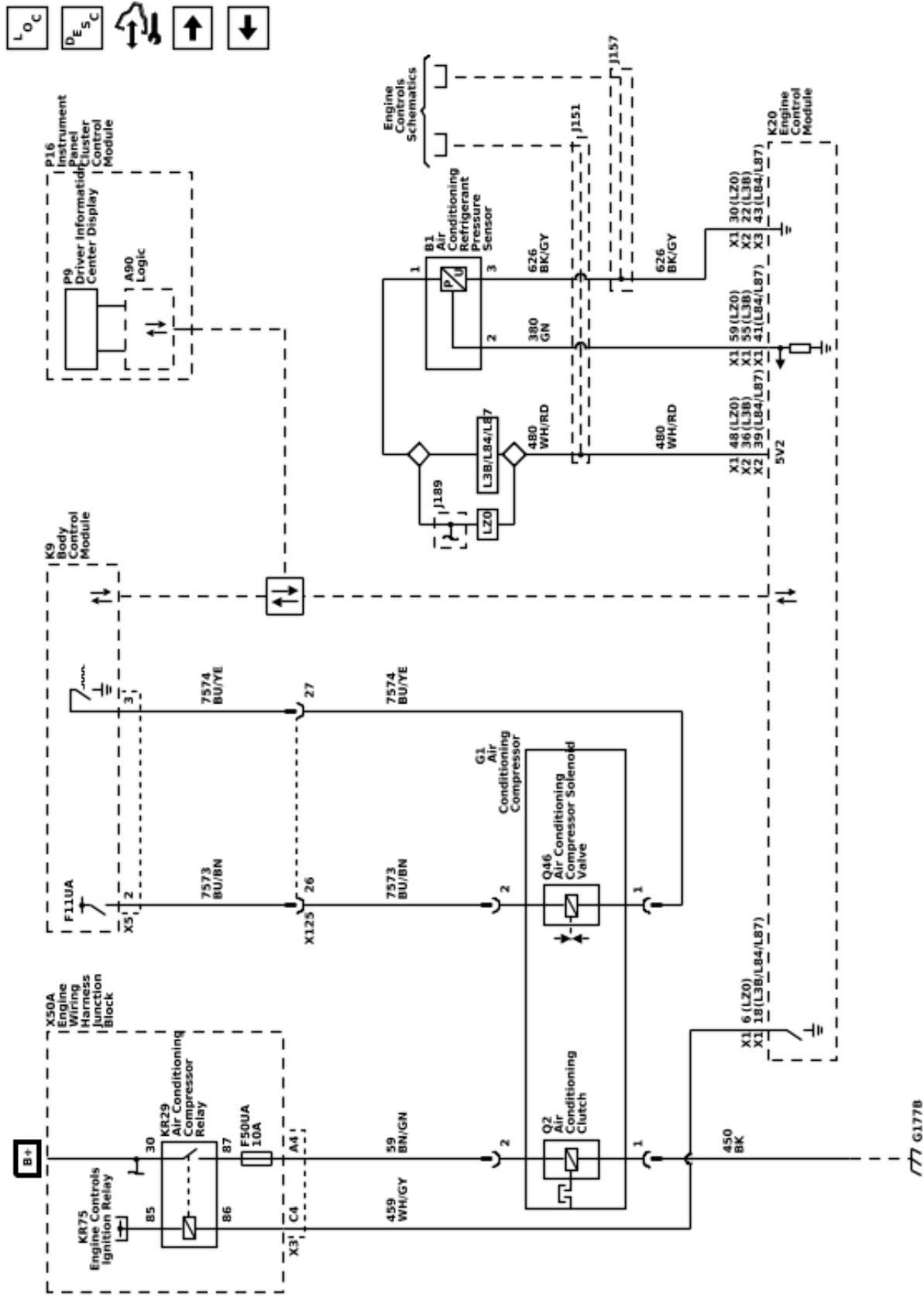

HVAC Schematics (Air Heater (C32))

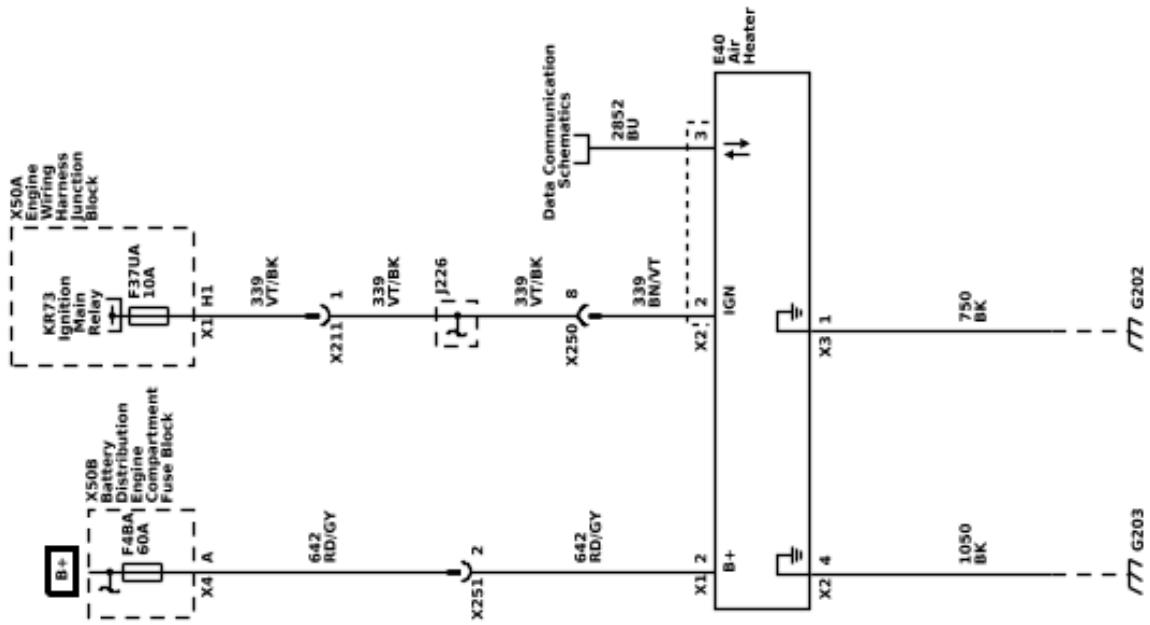

## **Description and Operation**

### **Heating and Air Conditioning System**

#### **Description and Operation**

#### **Engine Coolant**

Engine coolant is the key element of the heating system. The engine thermostat controls the normal engine operating coolant temperature. Coolant pumped out of the engine enters the heater core through the inlet heater hose. The air flowing through the Heating, Ventilation, and Air Conditioning (HVAC) module absorbs the heat of the coolant flowing through the heater core. The coolant then exits the heater core through the heater outlet hose and returns back to the engine block.

#### **Air Conditioning**

Refrigerant is the key element in an air conditioning system. R-1234yf is a very low temperature gas that can transfer the undesirable heat from the passenger compartment to the outside air.

The air conditioning compressor is belt driven and operates when the magnetic clutch is engaged. The compressor builds pressure in the air conditioning system. Compressing the refrigerant also adds heat to the refrigerant. The refrigerant is discharged from the compressor through the discharge hose, and forced to flow to the condenser and then through the balance of the air conditioning system. The air conditioning system is mechanically protected with the use of a high pressure relief valve. If the high pressure air conditioning switch were to fail or if the refrigerant system becomes restricted and refrigerant pressure continued to rise, the high pressure relief will pop open and release refrigerant from the system.

Compressed refrigerant enters the condenser in a high temperature, high pressure vapor state. As the refrigerant flows through the condenser, the heat of the refrigerant is transferred to the ambient air passing through the condenser. Cooling the refrigerant causes the refrigerant to condense and change from a vapor to a liquid state.

The condenser is located in front of the radiator for maximum heat transfer. The condenser is made of aluminum tubing and aluminum cooling fins, which allows rapid heat transfer for the refrigerant. The semi-cooled liquid refrigerant exits the condenser and flows through the liquid line, to the Thermostatic Expansion Valve (TXV).

The TXV is located at the evaporator inlet. The TXV is the dividing point for the high and the low pressure sides of the air conditioning system. As the refrigerant passes through the TXV, the refrigerant is lowered. Due to the pressure differential on the liquid refrigerant, the refrigerant will begin to boil at the TXV. The TXV also meters the amount of liquid refrigerant that can flow into the evaporator.

Refrigerant exiting the TXV flows into the evaporator core in a low pressure, liquid state. Ambient air is drawn through the HVAC module and passes through the evaporator core. Warm and moist air will cause the liquid refrigerant to boil inside the evaporator core.

The boiling refrigerant absorbs heat from the ambient air and draws moisture onto the evaporator. The refrigerant exits the evaporator through the suction line and back to the compressor, in a vapor state. This completes the air conditioning cycle of heat removal. At the compressor, the refrigerant is compressed again and the cycle of heat removal is repeated.

Vehicles equipped with R-1234yf may utilize an integral heat exchanger in the air conditioning line set. An integral heat exchanger transfers heat between liquid line and the suction line. It uses the cold vapor from the evaporator to cool the warm liquid refrigerant before it enters the TXV, resulting in increased cooling and higher efficiency.

The conditioned air is distributed through the HVAC module for passenger comfort. The moisture removed from the passenger compartment will also change form, or condense, and is discharged from the HVAC module as water.



# HVAC - Automatic

## Schematic and Routing Diagrams

HVAC Schematics (HVAC Controls)

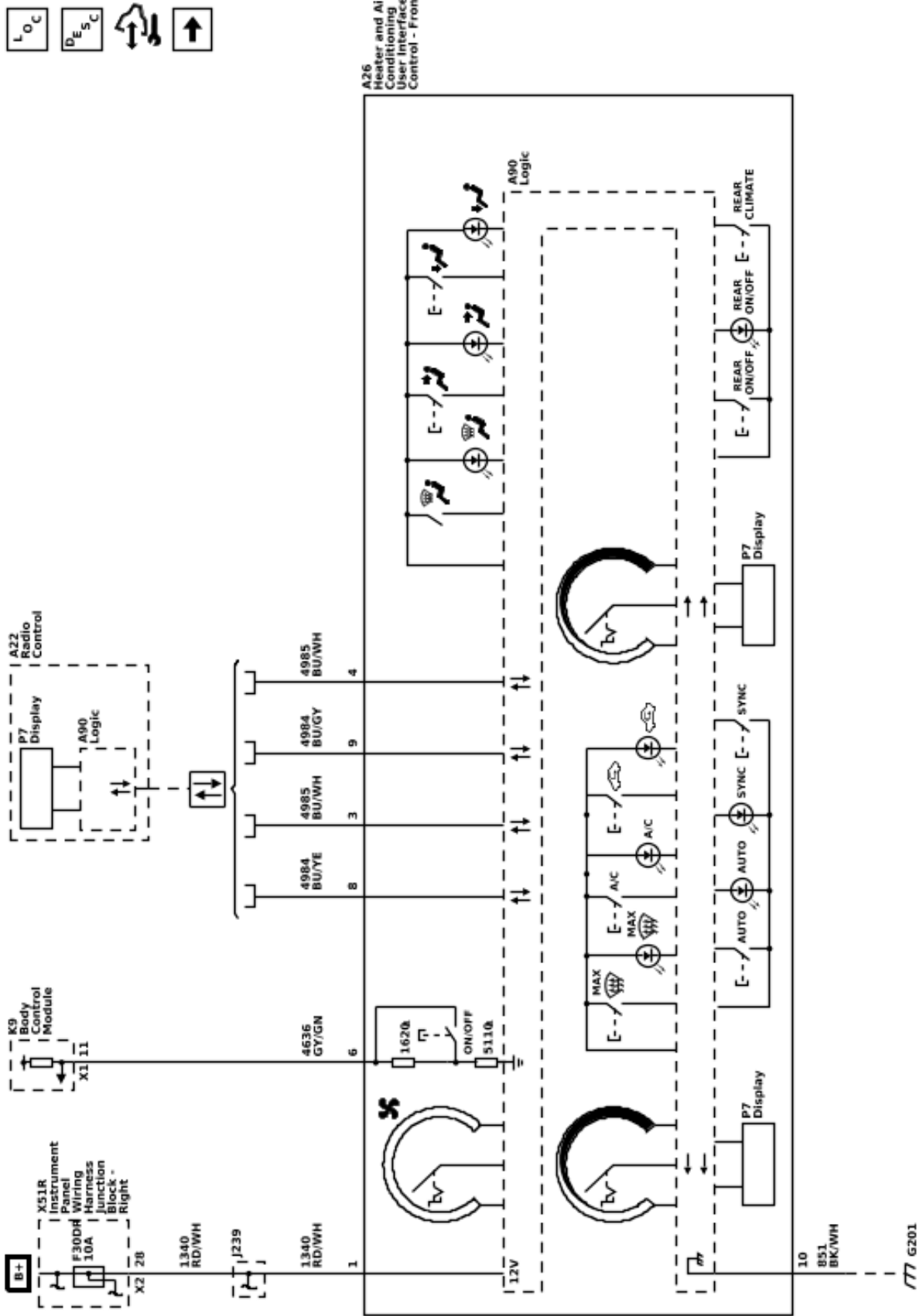
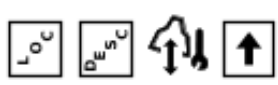

HVAC Schematics (Actuators)

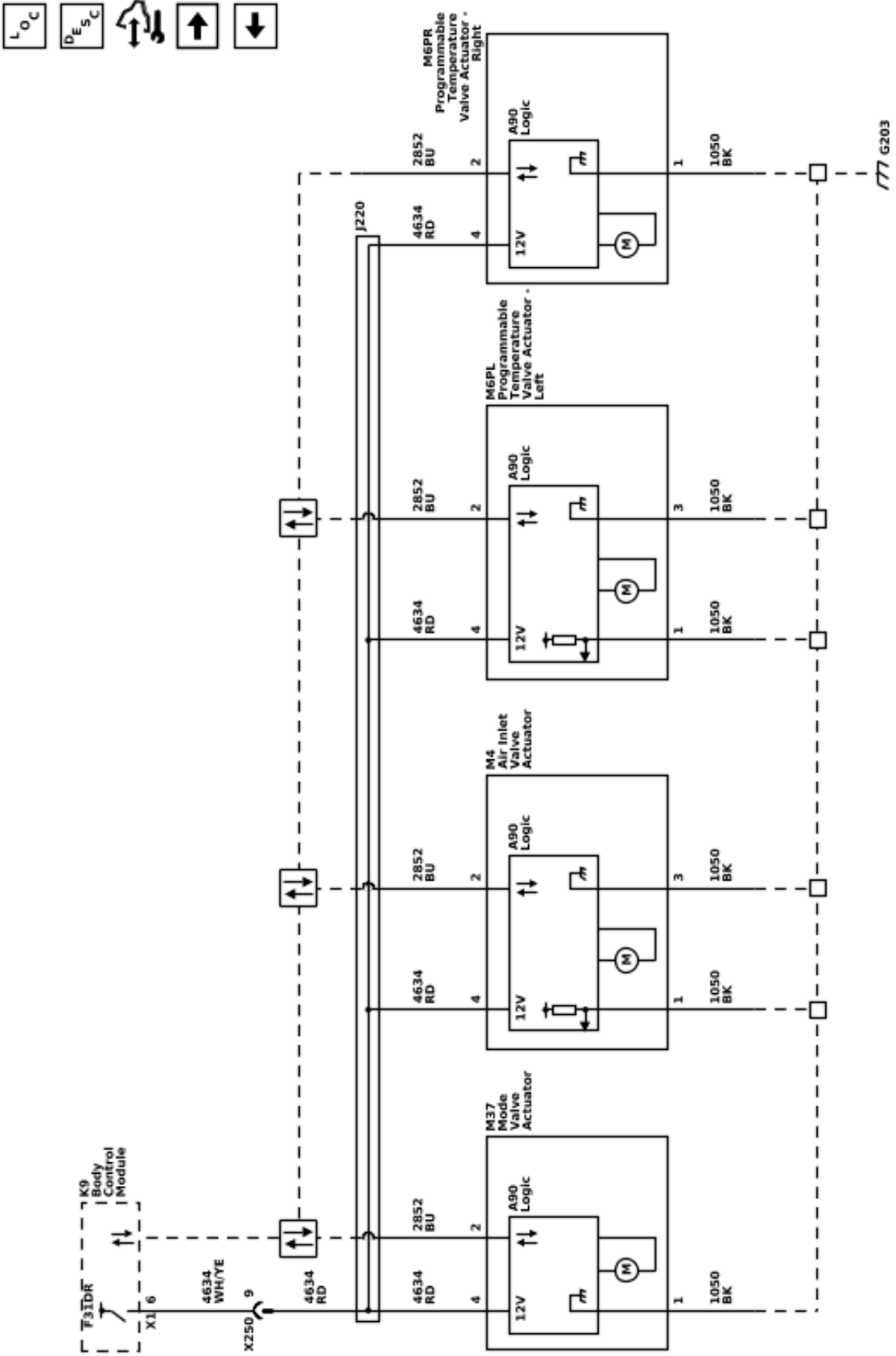

HVAC Schematics (Blower Motor)

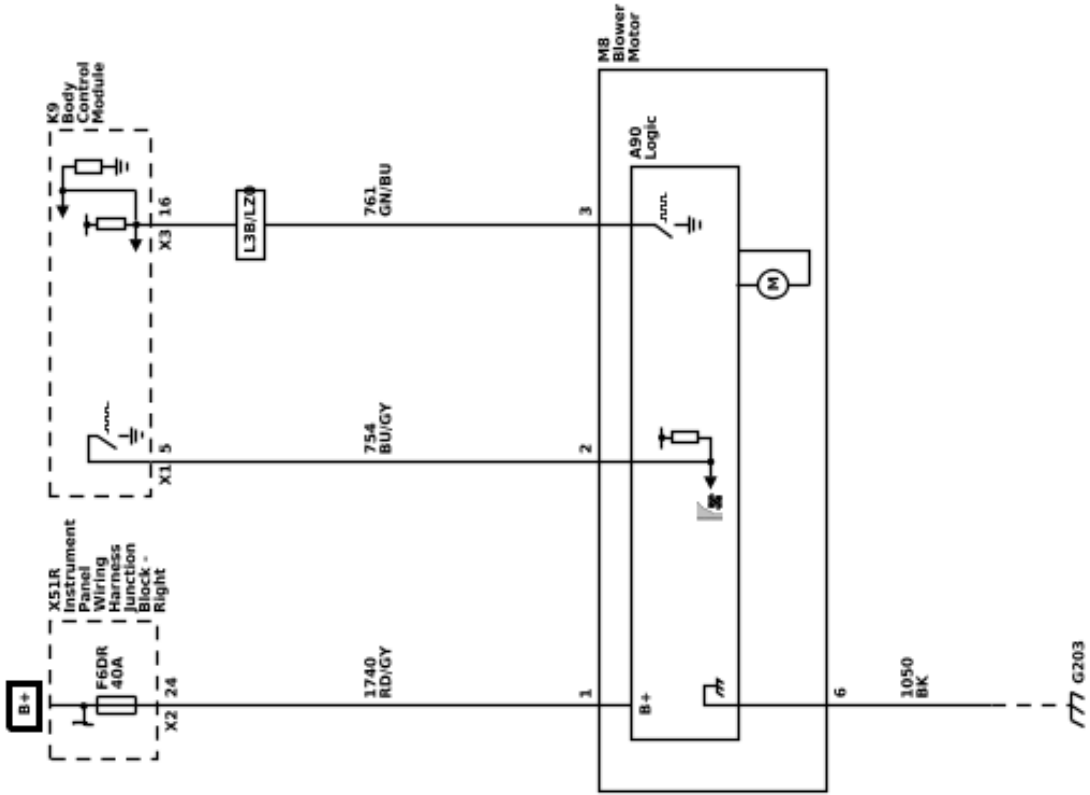

HVAC Schematics (Windshield Sensors and A/C Evaporator Temperature Sensor)

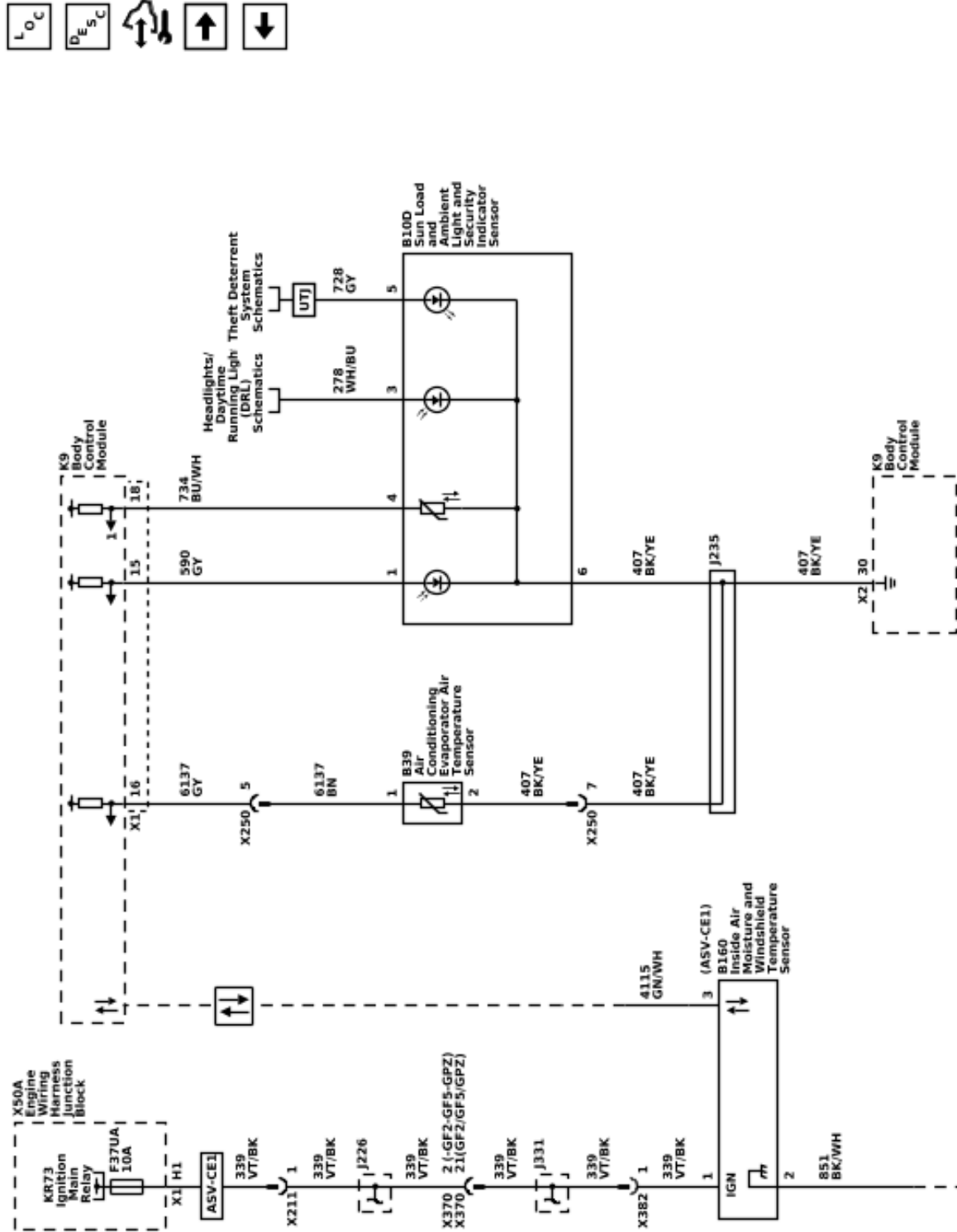

HVAC Schematics (A/C Compressor Controls)

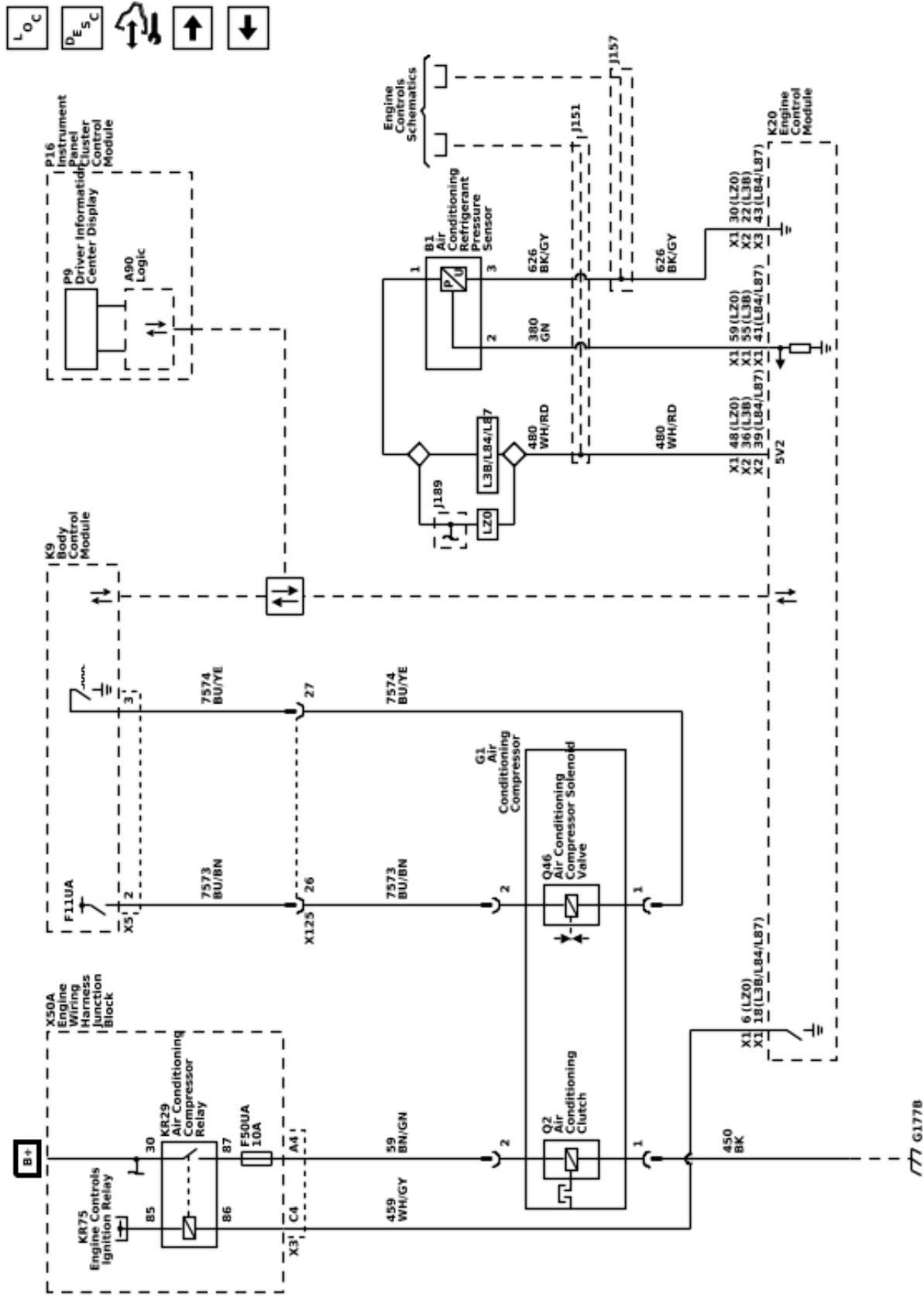

HVAC Schematics (Air Heater (C32))

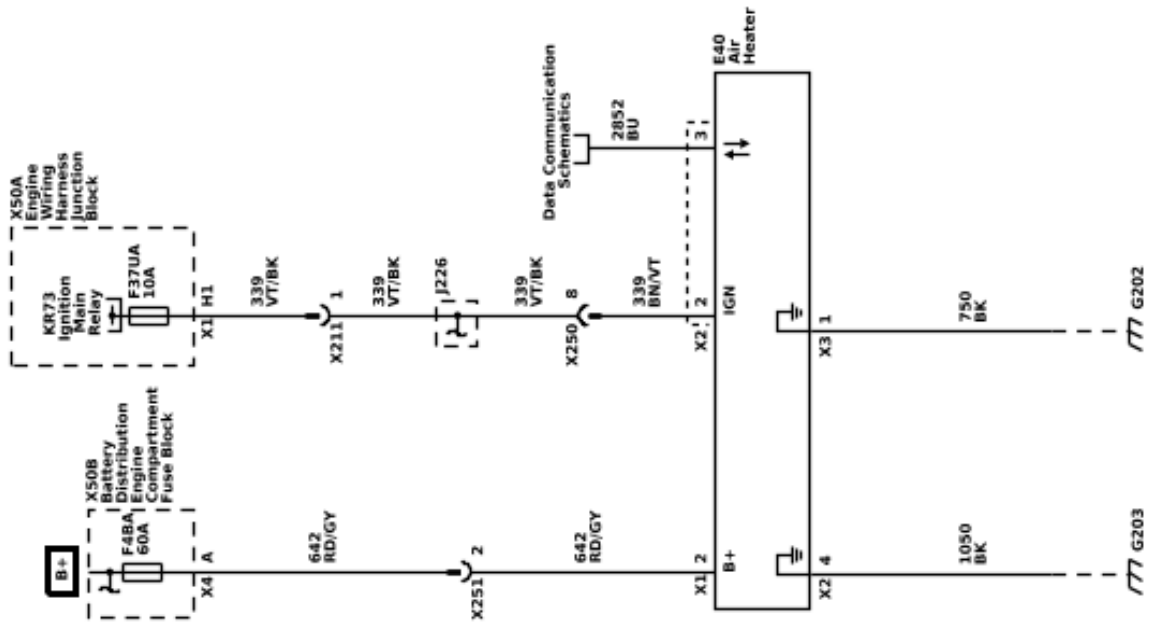

## Description and Operation

### Automatic HVAC Description and Operation

The air temperature and the air delivery description and operation are divided into the following:

- HVAC Control Components
- Air Speed and Blower Motor
- Air Delivery
- Heating and A/C Operation
- Recirculation Operation
- Automatic Operation
- Engine Coolant and A/C System Refrigerant

## HVAC Control Components

### K9 Body Control Module

The body control module (BCM) is a CAN device that interfaces between the operator and the HVAC system to maintain and control desired air temperature and air distribution settings. The BCM provides a device ON-Signal for the HVAC controls. The BCM provides blower, air delivery mode and air temperature control.

### A26 Heater and Air Conditioning User Interface Control - Front

The HVAC control contains all switches which are required to control the functions of HVAC and serve as interface between the operator and the BCM. The selected values are passed to the BCM via serial data.

### Actuators

Doors in the HVAC case assembly are used to control air flow. The BCM operates the doors through the use of actuators, with one actuator being used for each door. The system has the following air control doors and associated actuators: mode, left and right temperature, and recirculation.

Each actuator used in the system is a LIN device controlled by the BCM. The BCM supplies a 12 V reference voltage to the actuators, and ground is provided by the wiring harness. When the BCM sends a request message to the actuator, the actuator then operates internal stepper motors to move the door to the required position.

### Air Speed and M8 Blower Motor

The selected blower motor speed is passed from the controls to the BCM via serial data.

The motor uses a fused B+, ground, control, and speed output signal circuits to operate. The blower motor speed is controlled by increasing or decreasing the voltage drop on the ground side of the blower motor speed control circuit. The BCM provides a low side pulse width modulation (PWM) signal to the blower motor to request a specific motor speed. The blower motor internal circuitry translates the PWM signal and drives the motor accordingly.

The blower motor has a signal wire used to output a speed signal. The signal is monitored by the BCM. The BCM monitors the blower motor speed to modify the total commanded engine coolant flow rate, which is a percentage of available coolant flow sent to the heater

core for occupant comfort and windshield defrosting. The HVAC Blower Speed is monitored so that the ECM can optimize engine coolant flow for fuel economy and emissions.

### Afterblow

Afterblow is a feature that dries the evaporator core by operating the blower motor after the engine is turned OFF under certain conditions. This reduces the amount of moisture that can create undesirable odors. For additional information on afterblow, the default setting, and changing the setting, refer to Afterblow Configuration.

### Duct Air Temperature

Physical duct air temperature sensors are not used with the front system. The air temperature in the air distribution ducts is calculated by the BCM based on the engine coolant temperature, coolant flow, evaporator temperature, outside air temperature, solar load, blower motor speed, air inlet door position, and temperature door position information. The BCM uses the values to calculate actuator position.

### B39 Air Conditioning Evaporator Air Temperature Sensor

The evaporator temperature sensor is a 2-wire negative temperature coefficient thermistor. The sensor operates within a temperature range of  $-40$  to  $+85^{\circ}\text{C}$  ( $-40$  to  $+185^{\circ}\text{F}$ ). The sensor is installed near the evaporator core to measure the air temperature exiting the core.

Based on vehicle operating conditions and operator settings, the HVAC software algorithms will determine a target evaporator air temperature. The operation of the compressor solenoid will be adjusted as needed to quickly reach and maintain the targeted temperature.

### B1 Air Conditioning Refrigerant Pressure Sensor

The A/C refrigerant pressure sensor is a 3-wire piezoelectric pressure transducer. A 5 V reference voltage, low reference, and signal circuits enable the sensor to operate. The A/C pressure signal can be between 0.2–4.8 V. When the A/C refrigerant pressure is low, the signal value is near 0 V. When the A/C refrigerant pressure is high, the signal value is near 5 V. The engine control module (ECM) converts the voltage signal to a pressure value. When pressure is too high or too low, the ECM will not allow the A/C compressor clutch to engage.

### G1 Air Conditioning Compressor

The A/C compressor uses a conventional belt driven magnetic clutch to engage and mechanically turn the compressor. When the A/C switch is pressed, the BCM sends an A/C request message to the ECM via serial data. If specific criteria is met, the ECM then grounds the A/C compressor clutch relay control circuit, which will switch the A/C compressor clutch relay. With the relay contacts closed, battery voltage is supplied to the permanently grounded A/C compressor clutch. The A/C compressor clutch will then be activated.

This A/C system utilizes a variable displacement solenoid valve to alter the amount of displacement created by the turning of the compressor. The BCM provides both battery voltage and a pulse width modulated ground to the Q46 Air Conditioning



Compressor Solenoid Valve. When the A/C switch is pressed, the BCM grounds the variable displacement solenoid using a (PWM) signal in order to determine the amount of compressor displacement. The performance of the A/C compressor is regulated based on cooling load.

### **B160 Inside Air Moisture and Windshield Temperature Sensor**

The windshield temperature and inside moisture sensor includes the relative humidity sensor, windshield temperature sensor and humidity sensing element temperature sensor.

This sensor assembly provides information about:

- Relative humidity level at windshield (passenger compartment side)
- Temperature of the windshield (passenger compartment side)
- Temperature of the humidity sensor element

The relative humidity sensor measures the relative humidity of the passenger compartment side of the windshield. It also detects the temperature of the windshield surface on the passenger compartment side. Both values are used as control inputs for the BCM application to calculate the fog risk on windshield compartment side and ability to reduce fuel consumption by decreasing A/C compressor power to a minimum without causing any fog. The sensor will also enable partial recirculation mode in order to improve heat-up performance of the passenger compartment under cold ambient temperature conditions without the risk of mist build-up on the windshield. The humidity sensor element temperature sensor supplies the temperature of the humidity sensor element. It is only needed if the thermal contact between the humidity sensing element and the inside windshield surface is not sufficient.

The sensor is a LIN device, and the sensor values are transmitted to the BCM via serial data.

When equipped with CE1, the sensor is part of the B117A Windshield Outside Moisture/Ambient Light and Humidity Sensor LIN windshield sensor array, and the windshield temperature and humidity values are transmitted to the BCM via serial data.

### **B10D Sun Load Temperature and Ambient Light and Security Indicator Sensor**

The ambient light/sunload sensor includes the solar sensor and passenger compartment temperature sensor.

The solar sensor is connected to a low reference and 5 V supply through the BCM. As the sunload increases, the sensor signal voltage also increases and vice versa. The signal provided to the BCM varies between 1.2–4.85 V.

The passenger compartment temperature sensor is a negative temperature coefficient thermistor, connected to a low reference and 5 V supply through the BCM. As the air temperature increases, the sensor resistance decreases. The signal varies between 0–5 V.

Bright or high intensity light can cause the vehicles interior temperature to increase. The HVAC system uses the sensor values and compensates for the increased temperature to maintain the system settings.

### **E40 Air Heater (C32)**

Some models are equipped with an auxiliary electric heater to assist in warming the passenger compartment when the engine coolant has not sufficiently warmed to operating temperature. The air heater is a LIN device. The heater uses an ignition circuit, battery voltage circuit, ground circuit, and a serial data signal from the BCM to operate.

The heater is a 12 V positive temperature coefficient heating element located in the HVAC case just downstream of the traditional heater core. The system will activate the heater when the outside temperature is less than approximately 8°C (46°F), the engine coolant temperature is less than approximately 75°C (167°F), and the temperature blend door is commanded to the full hot position.

### **Air Delivery**

The BCM controls the distribution of air by the use of recirculation and mode door actuators. The modes that may be selected are:

- Defrost: windshield outlet
- Panel: dashboard outlets
- Floor: front footwell outlets
- Defog: defrost + floor
- Bi-level: panel + floor
- Tri-level: panel + defrost + floor
- Hi-level: panel + defrost

The desired air distribution mode can be selected with the air distribution switches at the HVAC control. The HVAC control delivers the values to the BCM via serial data. The BCM sends a request to the mode door actuator to move the door to the required position. Depending on the position of the door, air is distributed through various ducts leading to the outlets in the dash. When defrost airflow is active, the BCM will move the recirculation actuator to outside air, to aid in reducing window fogging. When defrost is selected the blower motor will be activated, regardless of the coolant temperature. A/C is available in all modes.

Refer to the owners manual for operation of the HVAC controls and mode selection.

### **Recirculation Operation**

The recirculation switch is integrated into the HVAC control. The selected recirculation setting is sent to the BCM via serial data. The BCM controls the air intake using the recirculation actuator. In recirculation mode the recirculation door is positioned to block outside air from entering and circulate the air within the vehicle. In outside air mode the recirculation door is positioned to route outside air into the vehicle.

Recirculation is only available if the defrost mode is not active. When the defrost mode is active, the recirculation actuator positions the recirculation door so that outside air is circulated to the windshield to reduce fogging.

In automatic mode the values of the sensors are used as inputs for the BCM to calculate the fog risk on the passenger compartment side of the windshield. The A/C compressor and the defrost mode may be activated to prevent or remove fog on the passenger compartment side of the windshield.

In automatic mode, a partial recirculation mode may be commanded to accelerate cabin heating or cooling and reduce energy usage. The recirculation indicator remains illuminated at all times, regardless of the actual operating mode determined by the system.

## Heating and A/C Operation

The purpose of the heating and A/C system is to provide heated and cooled air to the interior of the vehicle. The A/C system will also remove humidity from the interior and reduce windshield fogging. Regardless of the temperature setting, the following may affect the rate that the HVAC system can achieve the desired temperature:

- Recirculation setting
- Difference between inside and desired temperature
- Blower motor speed setting
- Mode setting
- Dashboard outlet open/closed position

When the A/C switch or the AUTO switch is pressed, the HVAC control sends a signal to the BCM via serial data. The BCM evaluates this signal and sends an A/C request signal to the ECM via CAN-Bus. The ECM checks all preconditions before releasing and if all conditions are met sends a release signal back to the BCM. The A/C compressor is activated by the BCM. The BCM supplies battery voltage to the A/C compressor solenoid. When the A/C switch is pressed, the BCM provides a pulse width modulation (PWM) signal to the A/C compressor solenoid in order to command the performance of the A/C compressor. The performance of the A/C compressor is regulated using evaporator temperature and engine load.

The A/C indicator does not indicate the compressor is currently active. The A/C indicator shows that A/C has been requested and the system will activate the compressor as needed.

The following conditions must be met in order to activate the A/C compressor:

- Battery voltage is between 9–18 V
- Engine coolant temperature is less than 124°C (255°F)
- Engine speed is greater than 600 RPM
- Engine speed is less than 5 500 RPM
- A/C high side pressure is between 269–2 929 kPa (39–425 PSI)
- Throttle position is less than 100%
- Evaporator temperature is greater than 3°C (38°F)
- ECM does not detect immoderate torque load
- ECM does not detect insufficient idle quality
- The ambient temperature is above 1°C (34°F)

The sensor information is used by the ECM to determine the following:

- The A/C high side pressure
- An A/C system load on the engine
- An immoderate A/C high side pressure
- The heat load at the A/C condenser

The air streams into the passenger compartment through the heater core and the evaporator core. The air temperature actuator drives the mixed air door to direct the airflow. If the interior temperature should be increased, the mixed air door is put into the position in which more air streams through the heater core. If the interior temperature should be decreased, the mixed air door is put into the position in which more air streams through the evaporator core.

## Automatic Operation

In automatic operation, the BCM maintains the comfort level inside of the vehicle by controlling the A/C compressor solenoid, the blower motor, the air temperature actuators, mode actuator and recirculation actuator.

The automatic mode indicator shows that the system is in full automatic operation. If an individual setting is changed (excluding temperature), the automatic indicator will turn off, and that function will enter manual control. All other functions will remain under automatic control unless manually changed.

To put the HVAC system in automatic mode, the following is required:

1. The auto switch must be activated.
2. The air temperature switch must not be in either the full hot or full cold position.

Once the desired temperature is reached, the blower motor, mode, recirculation and temperature actuators automatically adjust to maintain the temperature selected. The BCM performs the following functions to maintain the desired air temperature:

- Monitors the following:
  - Ambient (outside) air temperature sensor
  - Passenger compartment temperature sensor
  - Calculated front duct air temperatures
  - Windshield temperature and inside moisture sensor
  - Evaporator temperature sensor
  - Ambient light/sunload sensor
- Regulate the blower motor speed
- Position the air temperature actuators
- Position the mode door actuators
- Position the recirculation actuator
- Control of the A/C compressor solenoid

When the temperature setting is set to full hot, the blower speed will increase gradually as the coolant warms to normal operating temperature. When normal engine operating temperature is reached the blower stays on high speed and the air temperature actuators stays in the full heat position.

When the temperature setting is set to full cold, the blower will immediately operate at high speed and the air temperature actuators move to full cold position. The mode actuator moves to the panel position and the recirculation actuator moves to the recirculation position.

Under cold ambient temperatures, the automatic HVAC system provides heat in the most efficient manner. The operator can select an extreme temperature setting but the system will not warm the vehicle any faster. Under

warm ambient temperatures, the automatic HVAC system also provides air conditioning in the most efficient manner. Selecting an extreme cool temperature will not cool the vehicle any faster.

In automatic mode the values of the windshield temperature and inside moisture sensor are used as control inputs for the BCM application to calculate the fog risk on the passenger compartment side of the windshield and ability to reduce fuel consumption by decreasing A/C compressor power to a minimum without causing any fog. The A/C compressor and the defrost mode are activated to prevent or remove fog on the passenger compartment side of the windshield. The sensor will also enable partial recirculation mode in order to improve heat-up performance of the passenger compartment under cold ambient temperature conditions without the risk of mist build-up on the windshield.

## **Engine Coolant and A/C System Refrigerant**

For information on engine coolant, coolant flow, A/C refrigerant, and the A/C refrigerant cycle, refer to [Heating and Air Conditioning System Description and Operation on page 5-16.](#)

# HVAC - Manual

## Schematic and Routing Diagrams

HVAC Schematics (HVAC Controls)

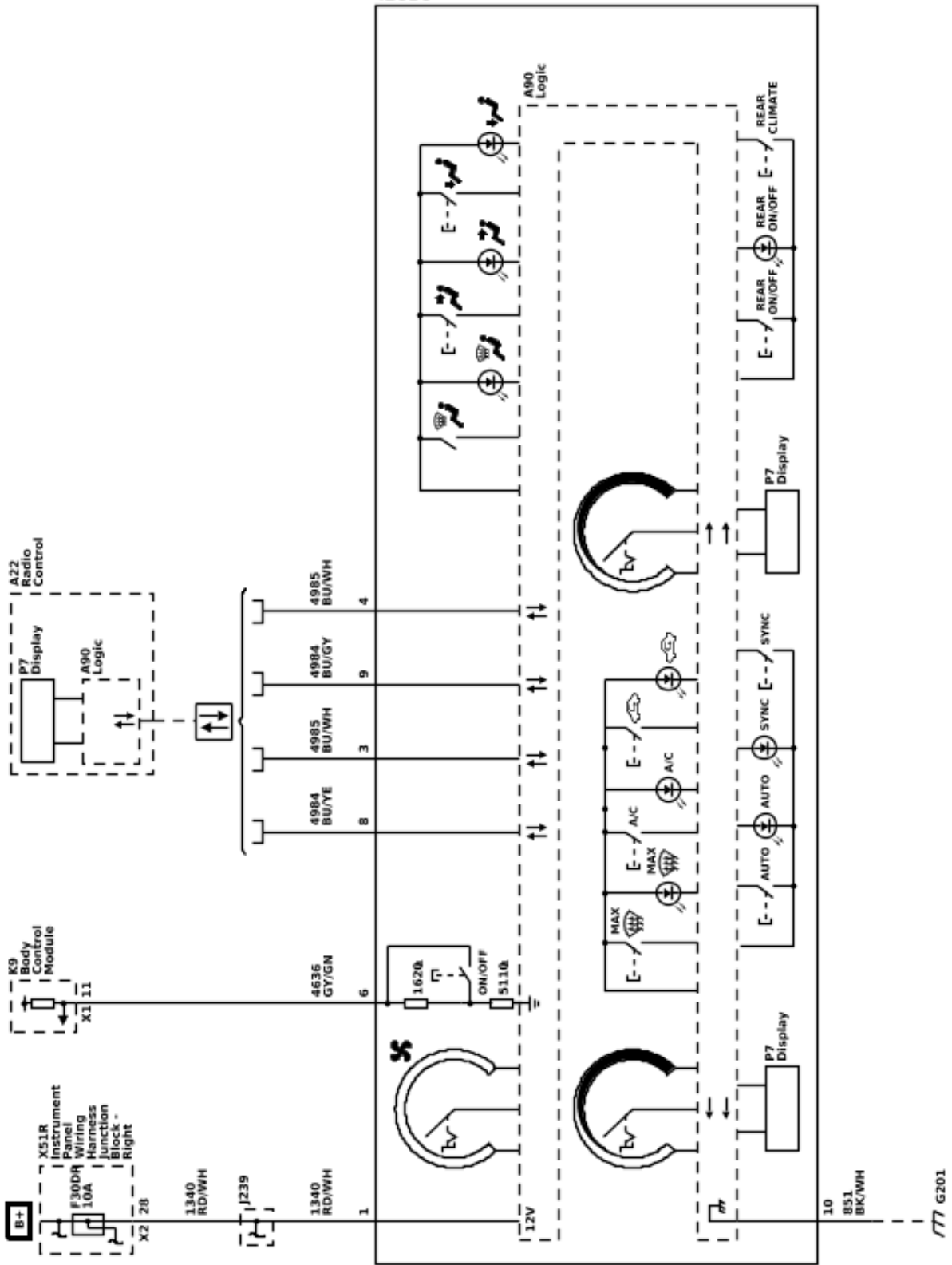
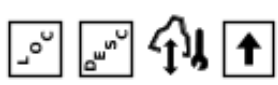

HVAC Schematics (Actuators)

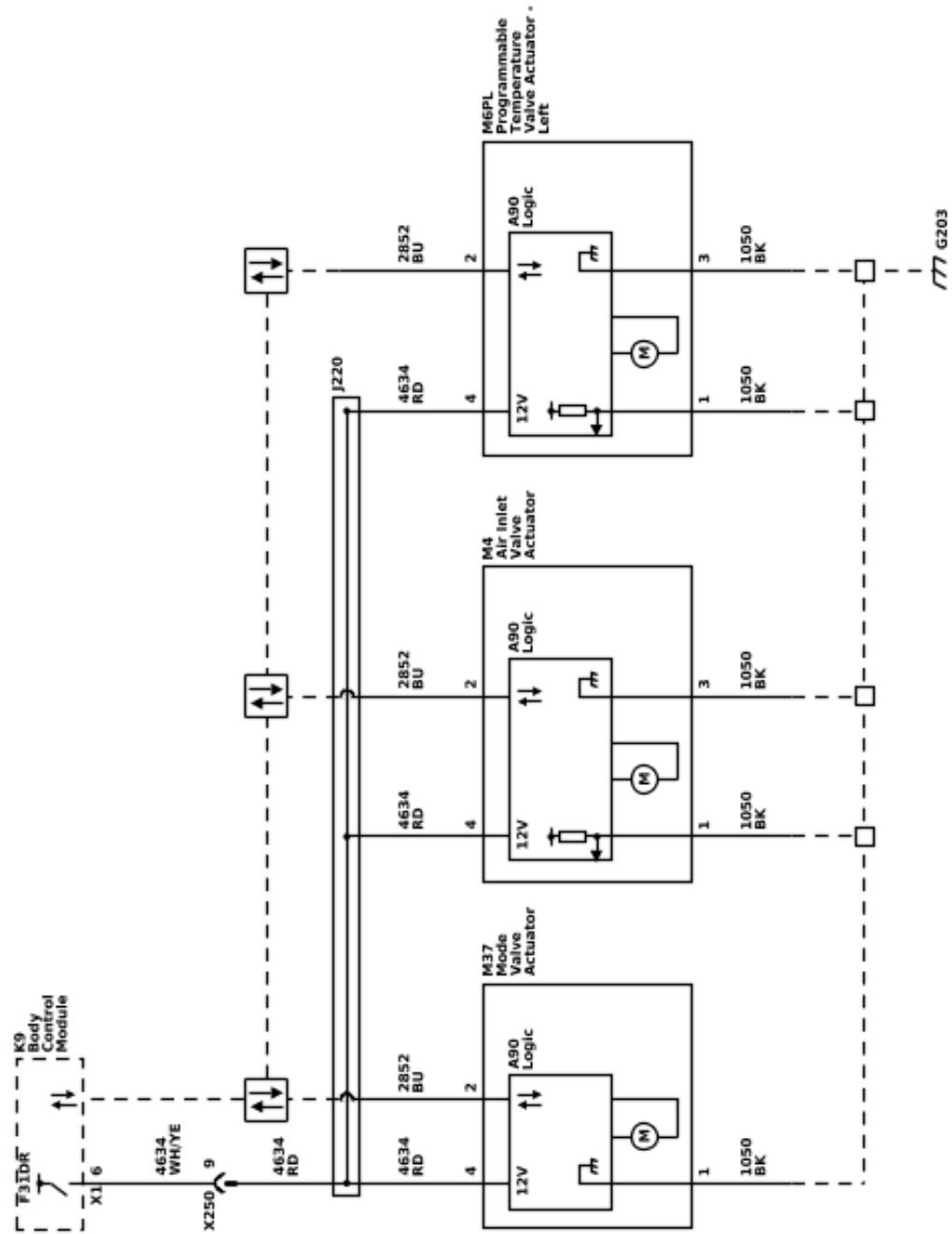

HVAC Schematics (Blower Motor)

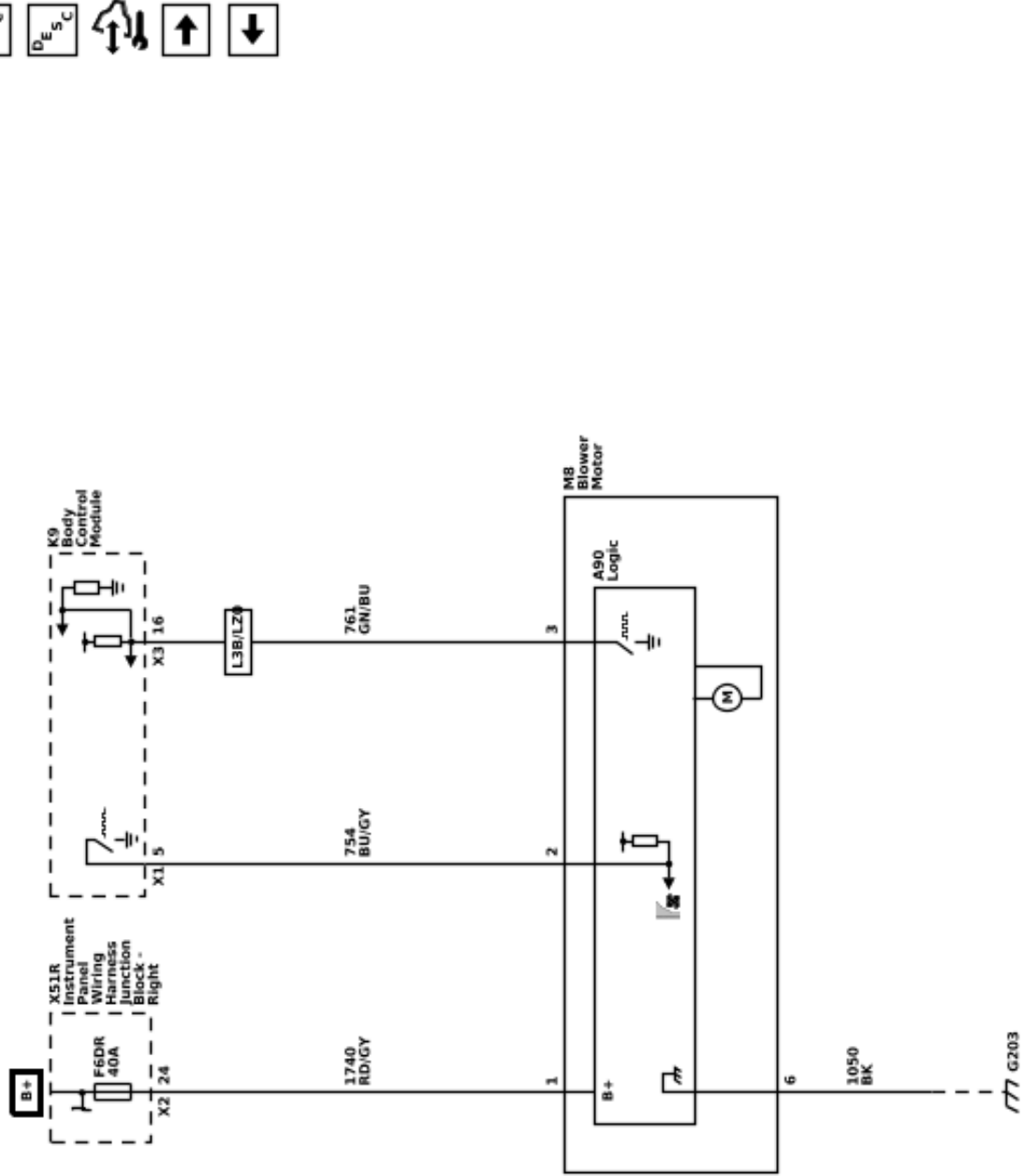

HVAC Schematics (Windshield Sensors and A/C Evaporator Temperature Sensor)

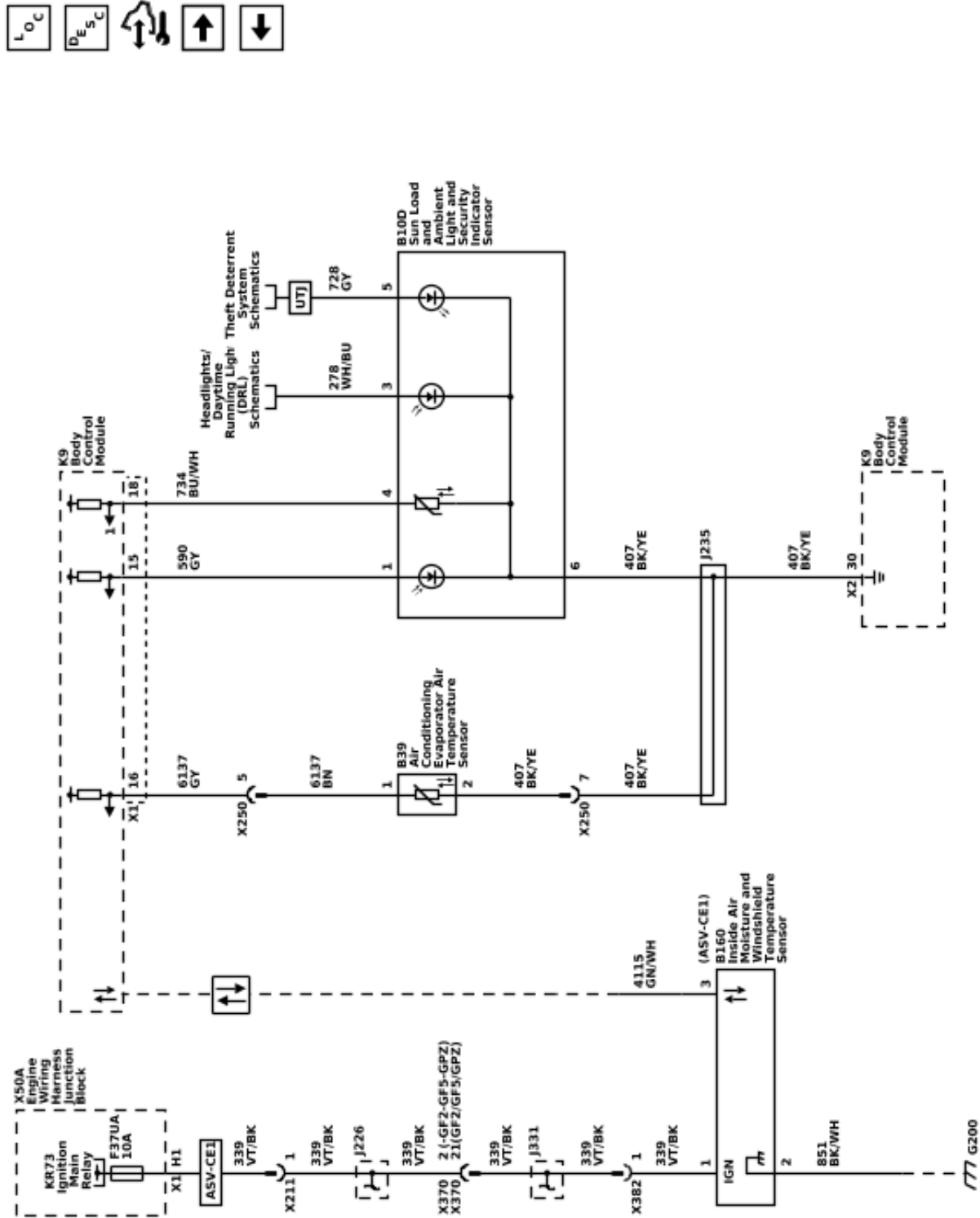



HVAC Schematics (A/C Compressor Controls)

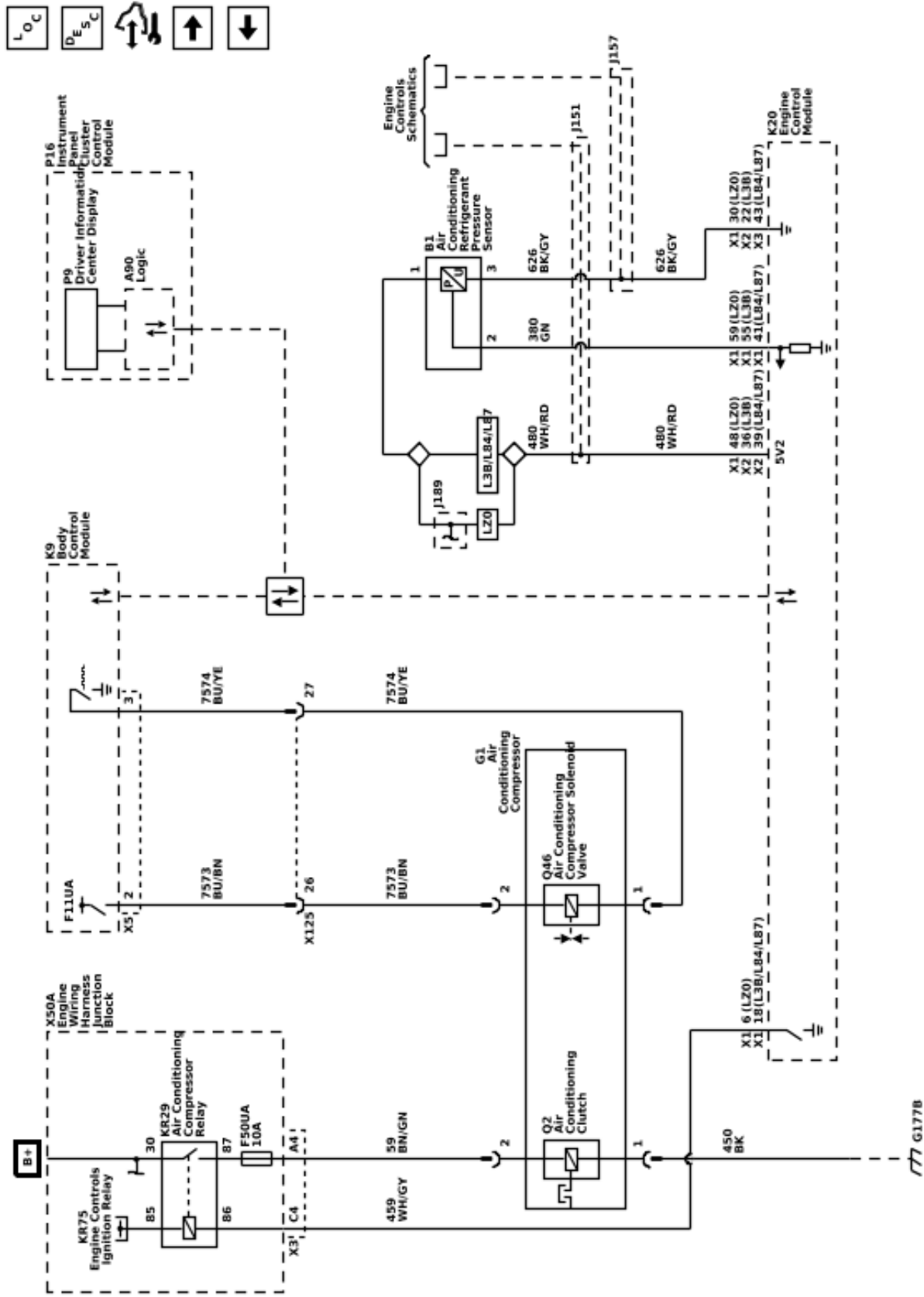

HVAC Schematics (Air Heater (C32))

LOC

DES

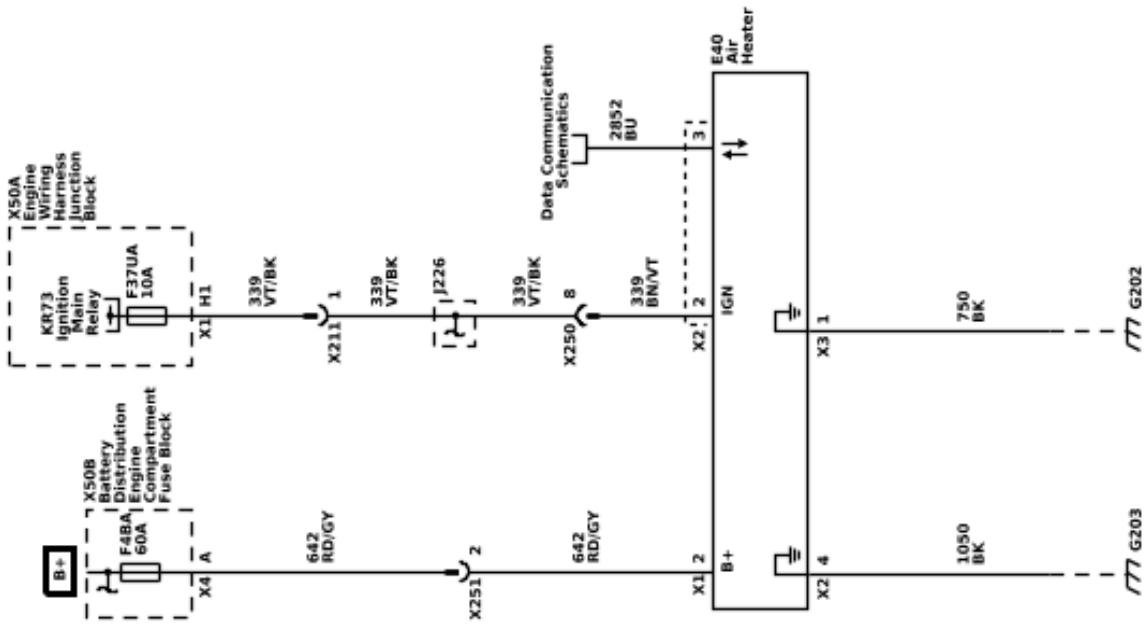

## Description and Operation

### Manual HVAC Description and Operation

The air temperature and the air delivery description and operation are divided into the following:

- HVAC Control Components
- Air Speed and Blower Motor
- Air Delivery
- Heating and A/C Operation
- Recirculation Operation
- Engine Coolant and A/C System Refrigerant

## HVAC Control Components

### K9 Body Control Module

The body control module (BCM) is a CAN device that interfaces between the operator and the HVAC system to maintain and control desired air temperature and air distribution settings. The BCM provides a device ON-Signal for the HVAC controls. The BCM provides blower, air delivery mode and air temperature control.

### A26 Heater and Air Conditioning User Interface Control - Front

The HVAC control contains all switches which are required to control the functions of HVAC and serve as interface between the operator and the BCM. The selected values are passed to the BCM via serial data.

### Actuators

Doors in the HVAC case assembly are used to control air flow. The BCM operates the doors through the use of actuators, with one actuator being used for each door. The system has the following air control doors and associated actuators: mode, temperature, and recirculation.

Each actuator used in the system is a LIN device controlled by the BCM. The BCM supplies a 12 V reference voltage to the actuators, and ground is provided by the wiring harness. When the BCM sends a request message to the actuator, the actuator then operates internal stepper motors to move the door to the required position.

### Air Speed and M8 Blower Motor

The selected blower motor speed is passed from the controls to the BCM via serial data.

The motor uses a fused B+, ground, control, and speed output signal circuits to operate. The blower motor speed is controlled by increasing or decreasing the voltage drop on the ground side of the blower motor speed control circuit. The BCM provides a low side pulse width modulation (PWM) signal to the blower motor to request a specific motor speed. The blower motor internal circuitry translates the PWM signal and drives the motor accordingly.

The blower motor has a signal wire used to output a speed signal. The signal is monitored by the BCM. The BCM monitors the blower motor speed to modify the total commanded engine coolant flow rate, which is a percentage of available coolant flow sent to the heater core for occupant comfort and windshield defrosting.

The HVAC Blower Speed is monitored so that the ECM can optimize engine coolant flow for fuel economy and emissions.

### Afterblow

Afterblow is a feature that dries the evaporator core by operating the blower motor after the engine is turned OFF under certain conditions. This reduces the amount of moisture that can create undesirable odors. For additional information on afterblow, the default setting, and changing the setting, refer to Afterblow Configuration.

### B39 Air Conditioning Evaporator Air Temperature Sensor

The evaporator temperature sensor is a 2-wire negative temperature coefficient thermistor. The sensor operates within a temperature range of  $-40$  to  $+85^{\circ}\text{C}$  ( $-40$  to  $+185^{\circ}\text{F}$ ). The sensor is installed near the evaporator core to measure the air temperature exiting the core.

Based on vehicle operating conditions and operator settings, the HVAC software algorithms will determine a target evaporator air temperature. The operation of the compressor solenoid will be adjusted as needed to quickly reach and maintain the targeted temperature.

### B1 Air Conditioning Refrigerant Pressure Sensor

The A/C refrigerant pressure sensor is a 3-wire piezoelectric pressure transducer. A 5 V reference voltage, low reference, and signal circuits enable the sensor to operate. The A/C pressure signal can be between 0.2–4.8 V. When the A/C refrigerant pressure is low, the signal value is near 0 V. When the A/C refrigerant pressure is high, the signal value is near 5 V. The engine control module (ECM) converts the voltage signal to a pressure value. When pressure is too high or too low, the ECM will not allow the A/C compressor clutch to engage.

### G1 Air Conditioning Compressor

The A/C compressor uses a conventional belt driven magnetic clutch to engage and mechanically turn the compressor. When the A/C switch is pressed, the BCM sends an A/C request message to the ECM via serial data. If specific criteria is met, the ECM then grounds the A/C compressor clutch relay control circuit, which will switch the A/C compressor clutch relay. With the relay contacts closed, battery voltage is supplied to the permanently grounded A/C compressor clutch. The A/C compressor clutch will then be activated.

This A/C system utilizes a variable displacement solenoid valve to alter the amount of displacement created by the turning of the compressor. The BCM provides both battery voltage and a pulse width modulated ground to the Q46 Air Conditioning Compressor Solenoid Valve. When the A/C switch is pressed, the BCM grounds the variable displacement solenoid using a (PWM) signal in order to determine the amount of compressor displacement. The performance of the A/C compressor is regulated based on cooling load.

### E40 Air Heater (C32)

Some models are equipped with an auxiliary electric heater to assist in warming the passenger compartment when the engine coolant has not sufficiently warmed to

operating temperature. The air heater is a LIN device. The heater uses an ignition circuit, battery voltage circuit, ground circuit, and a serial data signal from the BCM to operate.

The heater is a 12 V positive temperature coefficient heating element located in the HVAC case just downstream of the traditional heater core. The system will activate the heater when the outside temperature is less than approximately 8°C (46°F), the engine coolant temperature is less than approximately 75°C (167°F), and the temperature blend door is commanded to the full hot position.

## Air Delivery

The BCM controls the distribution of air by the use of recirculation and mode door actuators. The modes that may be selected are:

- Defrost: windshield outlet
- Panel: dashboard outlets
- Floor: front footwell outlets
- Defog: defrost + floor
- Bi-level: panel + floor
- Tri-level: panel + defrost + floor
- Hi-level: panel + defrost

The desired air distribution mode can be selected with the air distribution switches at the HVAC control. The HVAC control delivers the values to the BCM via serial data. The BCM sends a request to the mode door actuator to move the door to the required position. Depending on the position of the door, air is distributed through various ducts leading to the outlets in the dash. When defrost airflow is active, the BCM will move the recirculation actuator to outside air, to aid in reducing window fogging. When defrost is selected the blower motor will be activated, regardless of the coolant temperature. A/C is available in all modes.

Refer to the owners manual for operation of the HVAC controls and mode selection.

## Recirculation Operation

The recirculation switch is integrated into the HVAC control. The selected recirculation setting is sent to the BCM via serial data. The BCM controls the air intake using the recirculation actuator. In recirculation mode the recirculation door is positioned to block outside air from entering and circulate the air within the vehicle. In outside air mode the recirculation door is positioned to route outside air into the vehicle.

Recirculation is only available if the defrost mode is not active. When the defrost mode is active, the recirculation actuator positions the recirculation door so that outside air is circulated to the windshield to reduce fogging.

## Heating and A/C Operation

The purpose of the heating and A/C system is to provide heated and cooled air to the interior of the vehicle. The A/C system will also remove humidity from the interior and reduce windshield fogging. Regardless

of the temperature setting, the following may affect the rate that the HVAC system can achieve the desired temperature:

- Recirculation setting
- Difference between inside and desired temperature
- Blower motor speed setting
- Mode setting
- Dashboard outlet open/closed position

When the A/C switch or the AUTO switch is pressed, the HVAC control sends a signal to the BCM via serial data. The BCM evaluates this signal and sends an A/C request signal to the ECM via CAN-Bus. The ECM checks all preconditions before releasing and if all conditions are met sends a release signal back to the BCM. The A/C compressor is activated by the BCM. The BCM supplies battery voltage to the A/C compressor solenoid. When the A/C switch is pressed, the BCM provides a pulse width modulation (PWM) signal to the A/C compressor solenoid in order to command the performance of the A/C compressor. The performance of the A/C compressor is regulated using evaporator temperature and engine load.

The A/C indicator does not indicate the compressor is currently active. The A/C indicator shows that A/C has been requested and the system will activate the compressor as needed.

The following conditions must be met in order to activate the A/C compressor:

- Battery voltage is between 9–18 V
- Engine coolant temperature is less than 124°C (255°F)
- Engine speed is greater than 600 RPM
- Engine speed is less than 5 500 RPM
- A/C high side pressure is between 269–2 929 kPa (39–425 PSI)
- Throttle position is less than 100%
- Evaporator temperature is greater than 3°C (38°F)
- ECM does not detect immoderate torque load
- ECM does not detect insufficient idle quality
- The ambient temperature is above 1°C (34°F)

The sensor information is used by the ECM to determine the following:

- The A/C high side pressure
- An A/C system load on the engine
- An immoderate A/C high side pressure
- The heat load at the A/C condenser

The air streams into the passenger compartment through the heater core and the evaporator core. The air temperature actuator drives the mixed air door to direct the airflow. If the interior temperature should be increased, the mixed air door is put into the position in which more air streams through the heater core. If the interior temperature should be decreased, the mixed air door is put into the position in which more air streams through the evaporator core.

---

## Engine Coolant and A/C System Refrigerant

For information on engine coolant, coolant flow, A/C refrigerant, and the A/C refrigerant cycle, refer to [\*Heating and Air Conditioning System Description and Operation on page 5-16.\*](#)

**BLANK**

## Section 6

# Power and Signal Distribution

<b>Data Communications</b> .....	<a href="#">6-3</a>
<b>Schematic and Routing Diagrams</b> .....	<a href="#">6-3</a>
Data Communication Schematics .....	<a href="#">6-4</a>
Body Control System Schematics .....	<a href="#">6-24</a>
<b>Description and Operation</b> .....	<a href="#">6-27</a>
Data Link Communications Description and Operation .....	<a href="#">6-27</a>
<b>Electrical Component and Inline Harness</b>	
<b>Connector End Views</b> .....	<a href="#">6-30</a>
<b>Component Locator</b> .....	<a href="#">6-30</a>
Electrical Center Identification Views .....	<a href="#">6-30</a>
Component Connector End Views .....	<a href="#">6-80</a>
Inline Harness Connector End Views .....	<a href="#">6-747</a>
<b>Electrical Component Locator and Harness Routing Views</b> .....	<a href="#">6-914</a>
<b>Schematic and Routing Diagrams</b> .....	<a href="#">6-914</a>
Harness Routing Views .....	<a href="#">6-914</a>
<b>Power Outlets</b> .....	<a href="#">6-961</a>
Cigar Lighter/Power Outlet Schematics .....	<a href="#">6-962</a>
<b>Description and Operation</b> .....	<a href="#">6-973</a>
Mobile Device Wireless Charger Description and Operation .....	<a href="#">6-973</a>
Power Outlets Description and Operation .....	<a href="#">6-973</a>
<b>Wiring Systems and Power Management</b> .....	<a href="#">6-976</a>
Power Mode Description and Operation .....	<a href="#">6-976</a>
Retained Accessory Power Description and Operation .....	<a href="#">6-980</a>

**BLANK**



# Data Communications

## Schematic and Routing Diagrams

Data Communication Schematics (Data Link Connector and Serial Data Gateway Module Power and Ground)

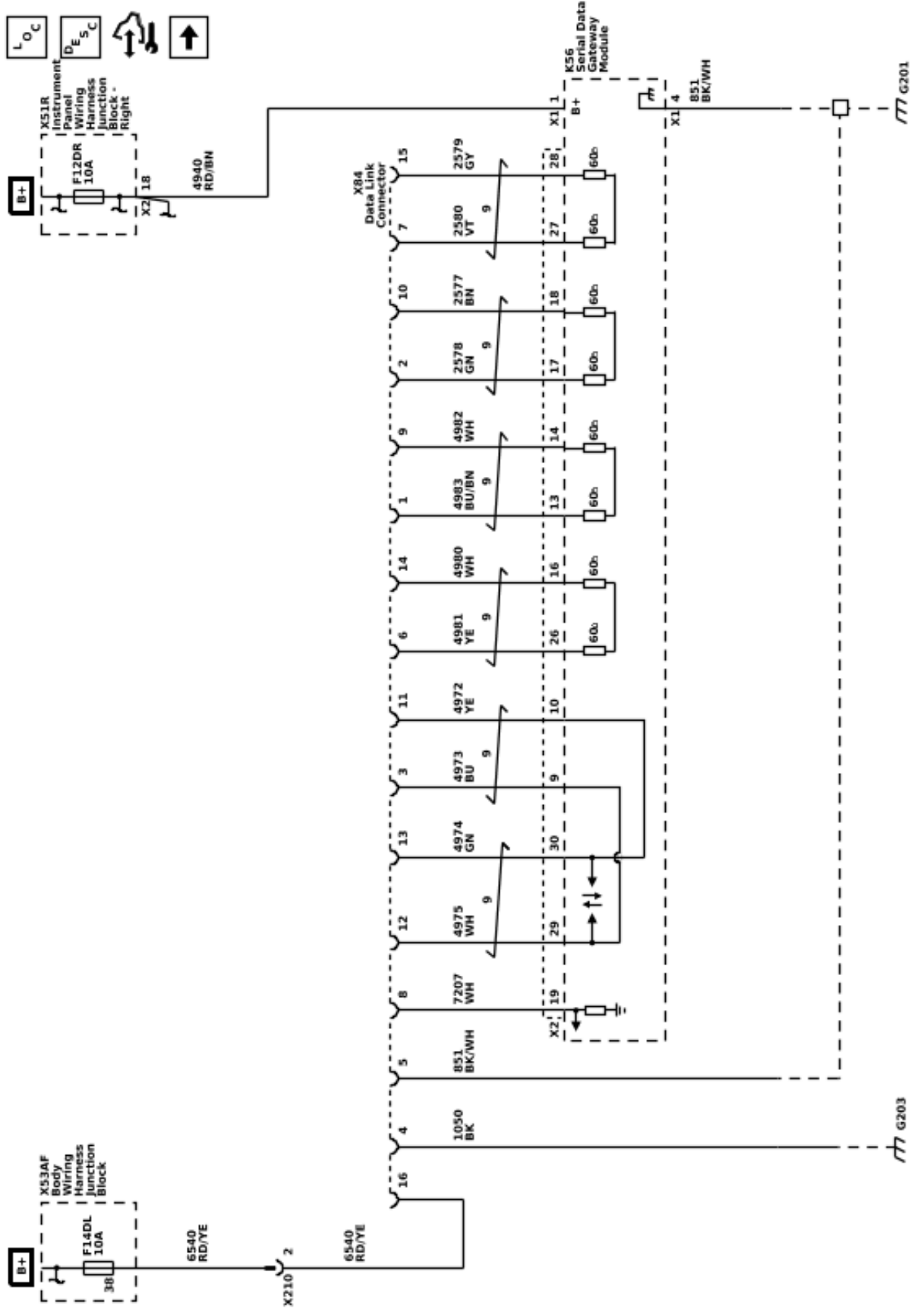

Data Communication Schematics (CAN 1 - 1 of 3)

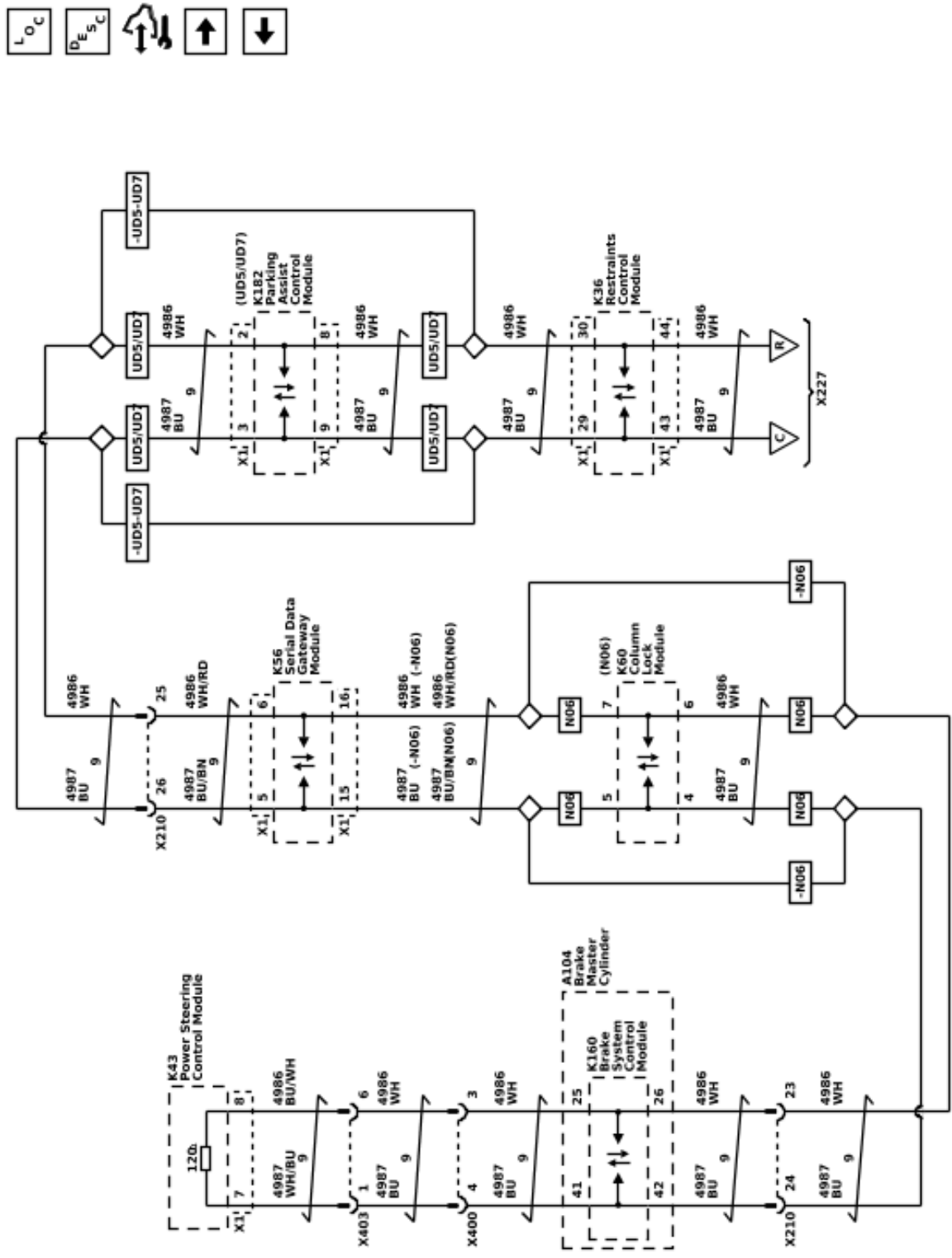

Data Communication Schematics (CAN 1 - 2 of 3)

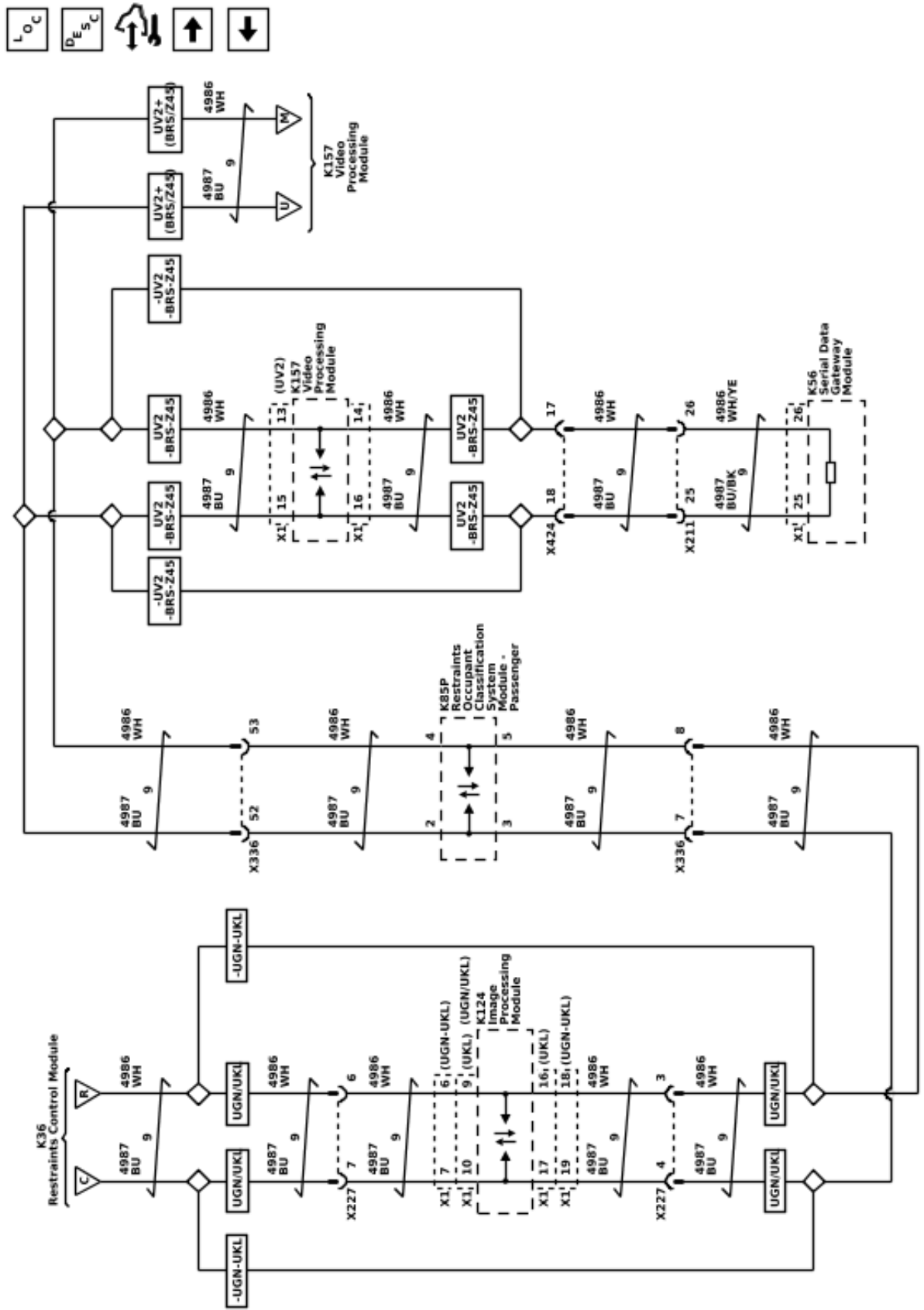

Data Communication Schematics (CAN 1 - 3 of 3)

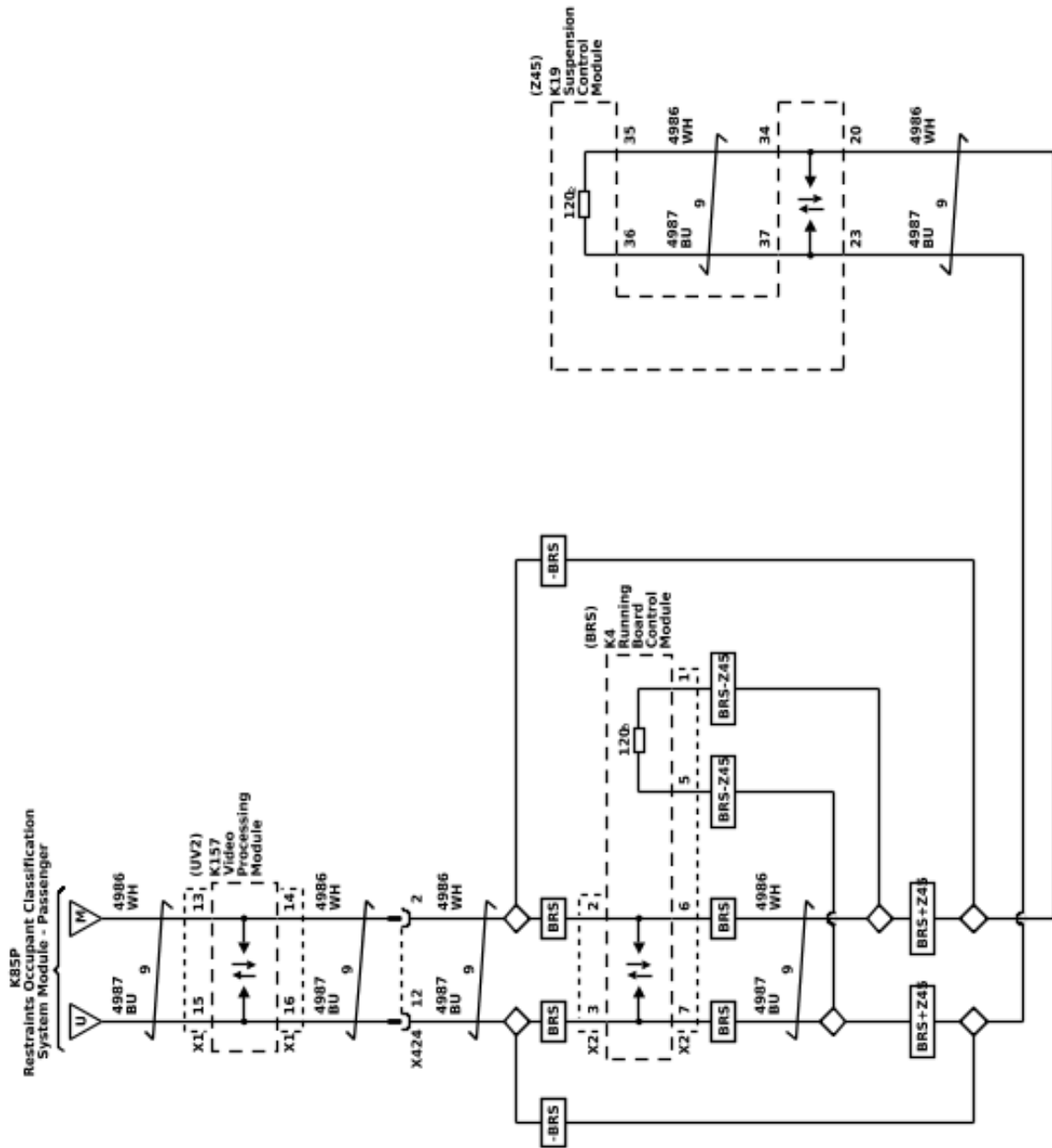

Data Communication Schematics (CAN 2 - 1 of 2)

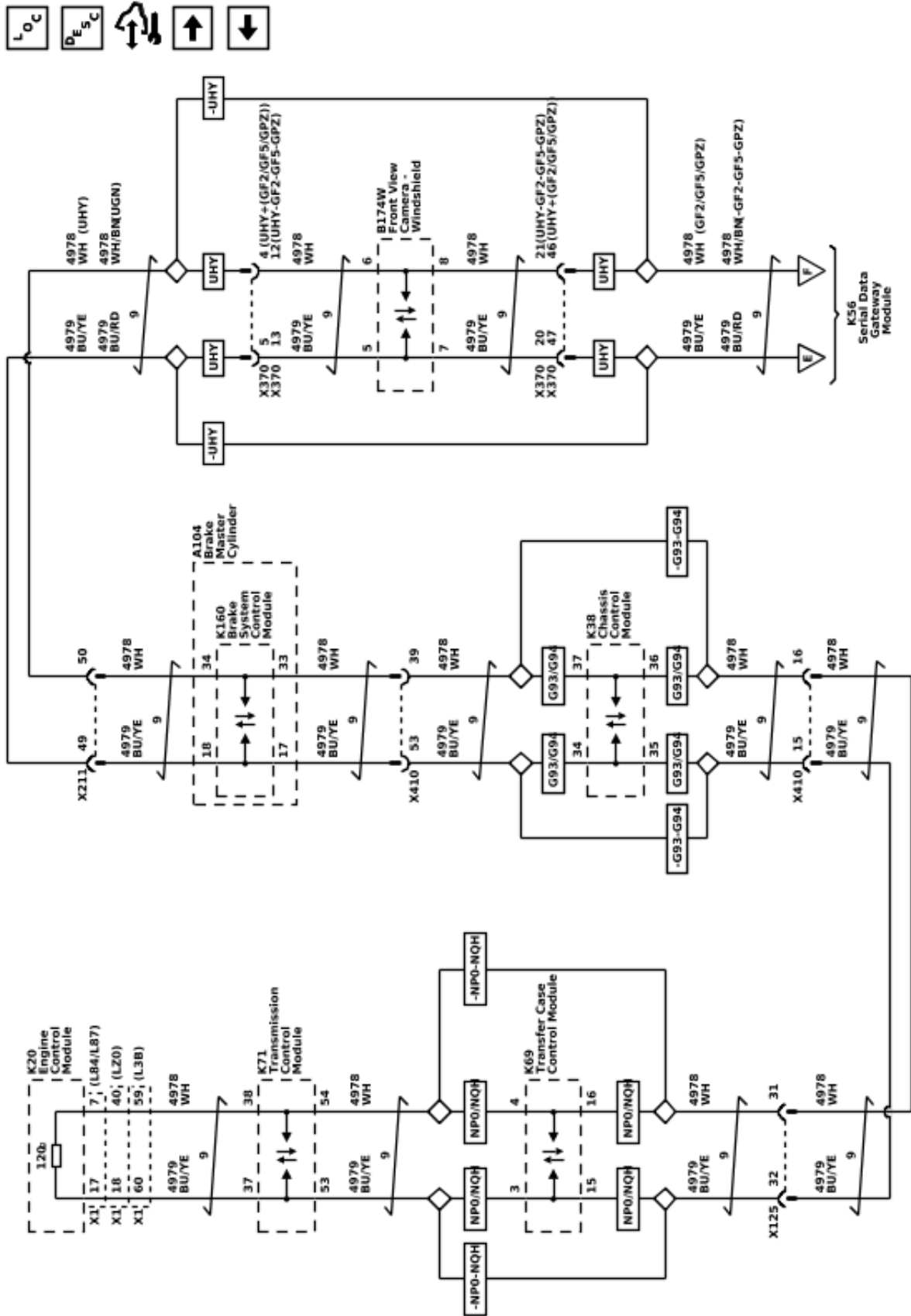

Data Communication Schematics (CAN 2 - 2 of 2)

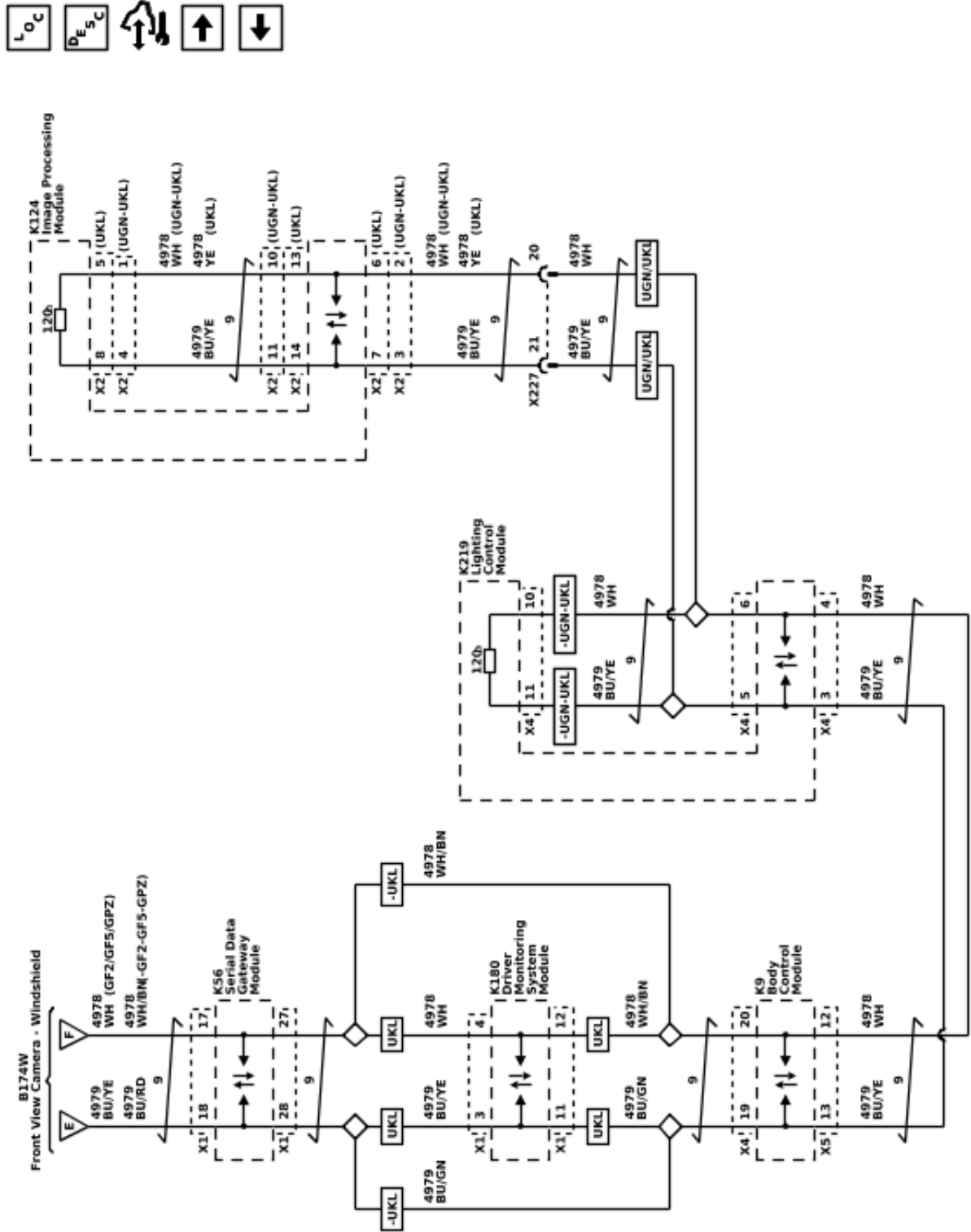

Data Communication Schematics (CAN 3)

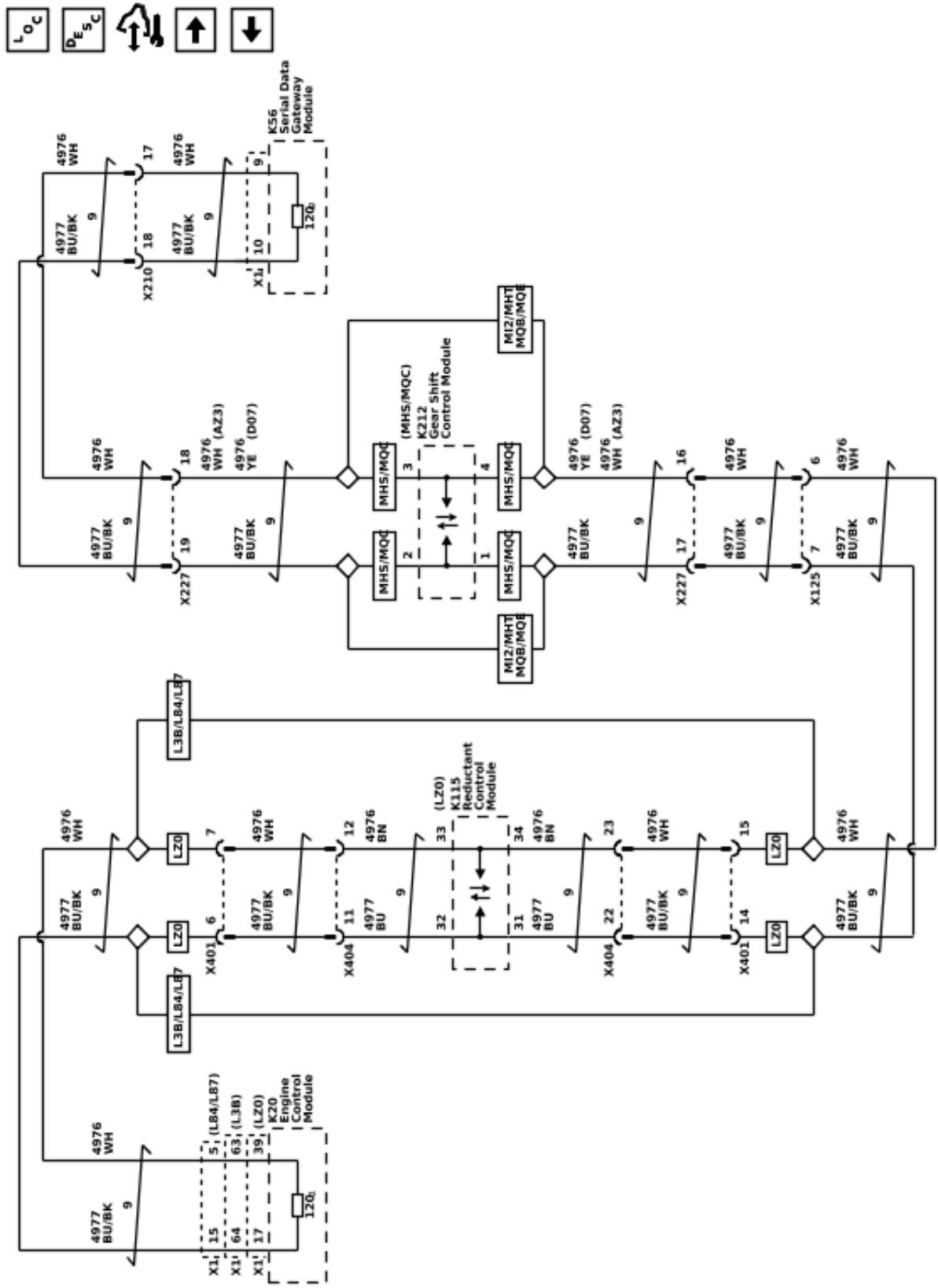



Data Communication Schematics (CAN 4)

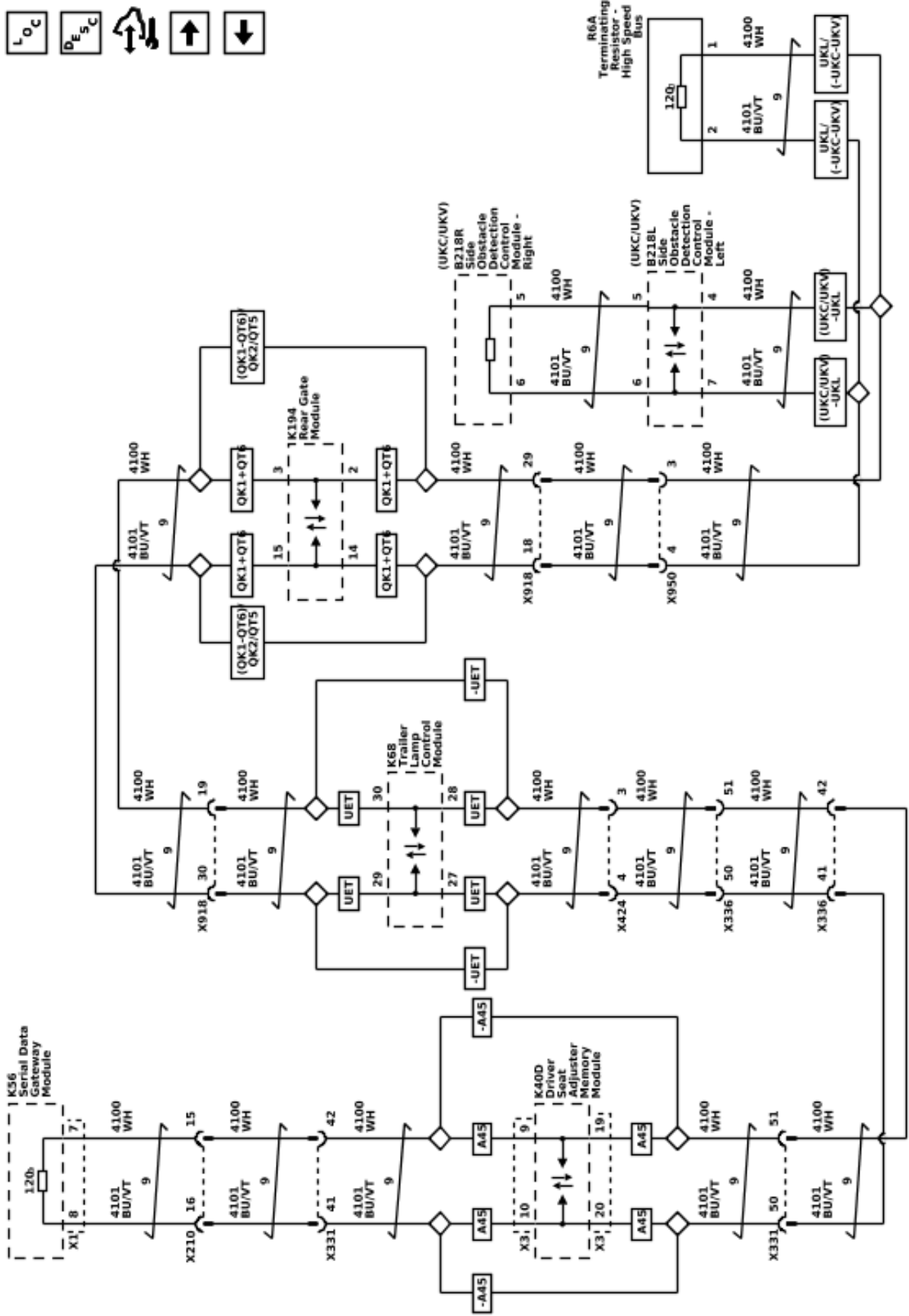

Data Communication Schematics (CAN 5)

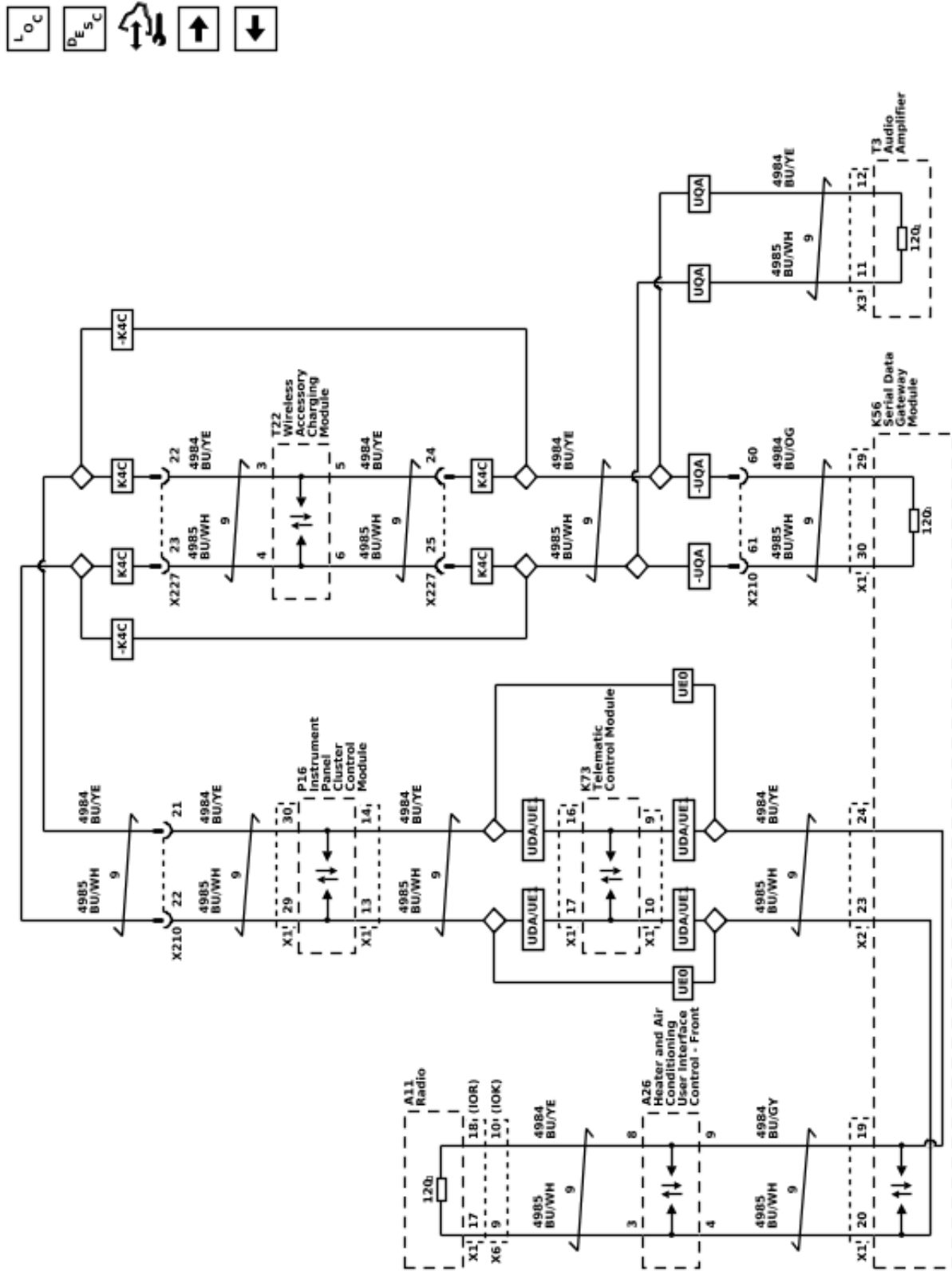

Data Communication Schematics (CAN 8 - 1 of 2 (UGN / UKL))

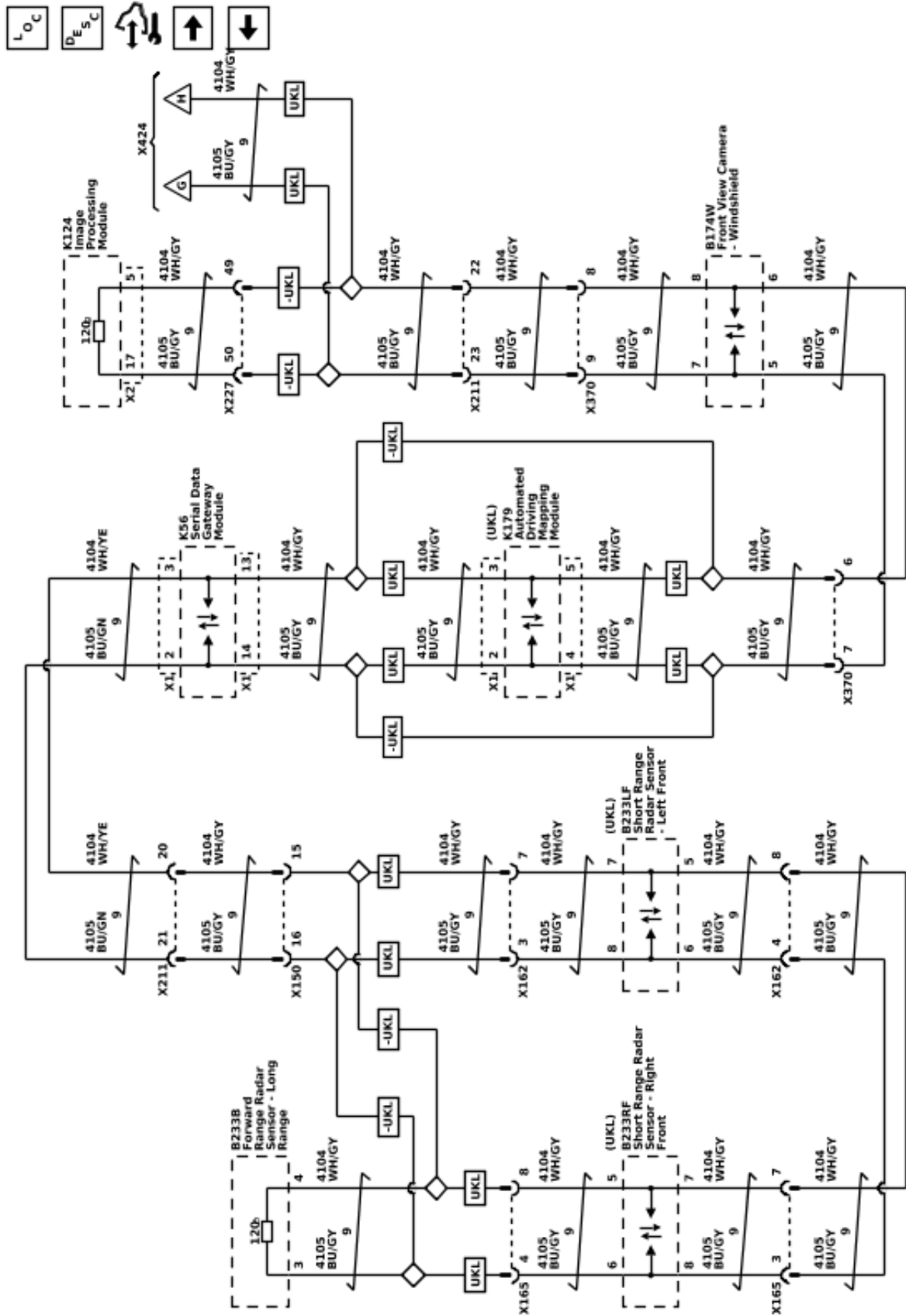

Data Communication Schematics (CAN 8 - 2 of 2 (UKL))

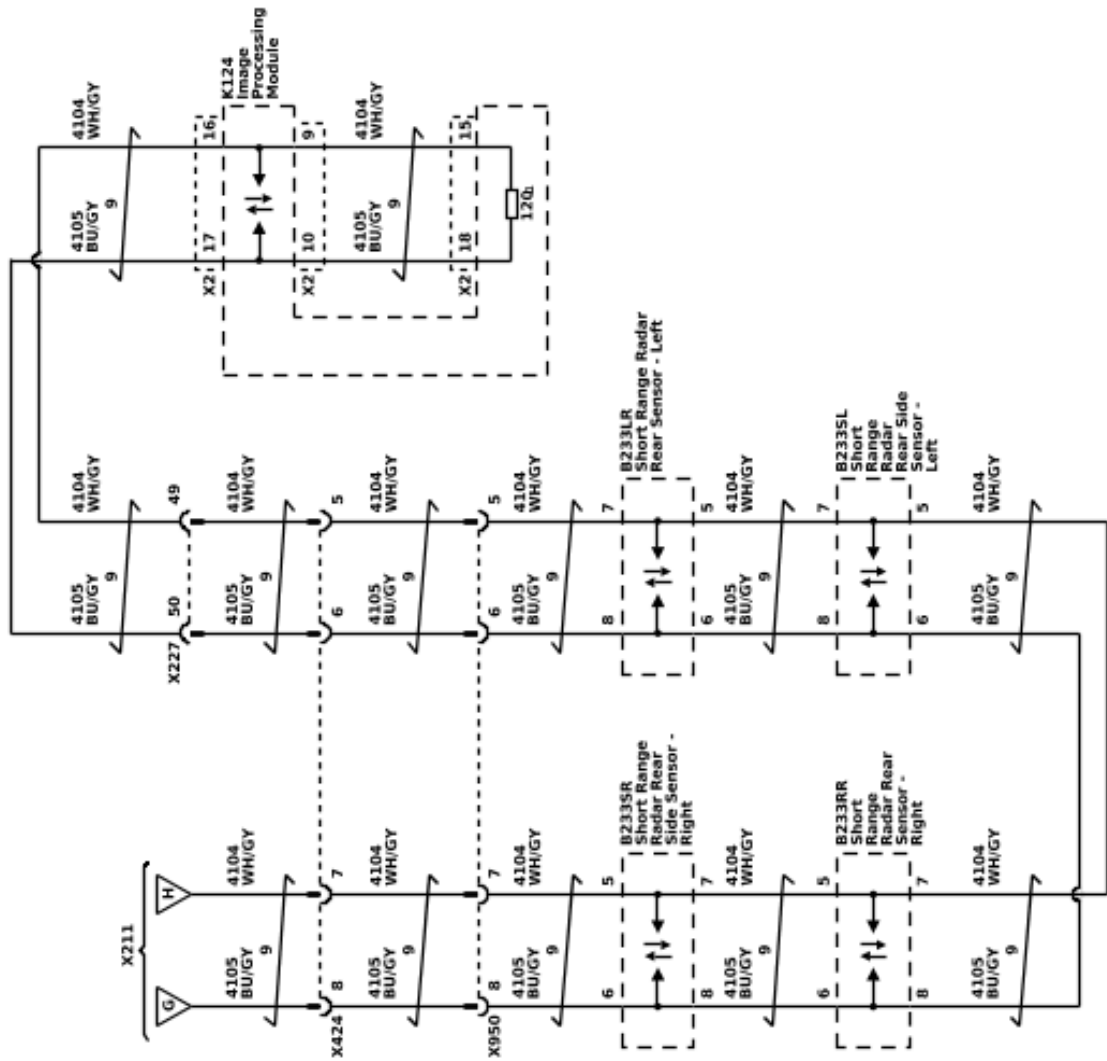

Data Communication Schematics (Powertrain CAN)

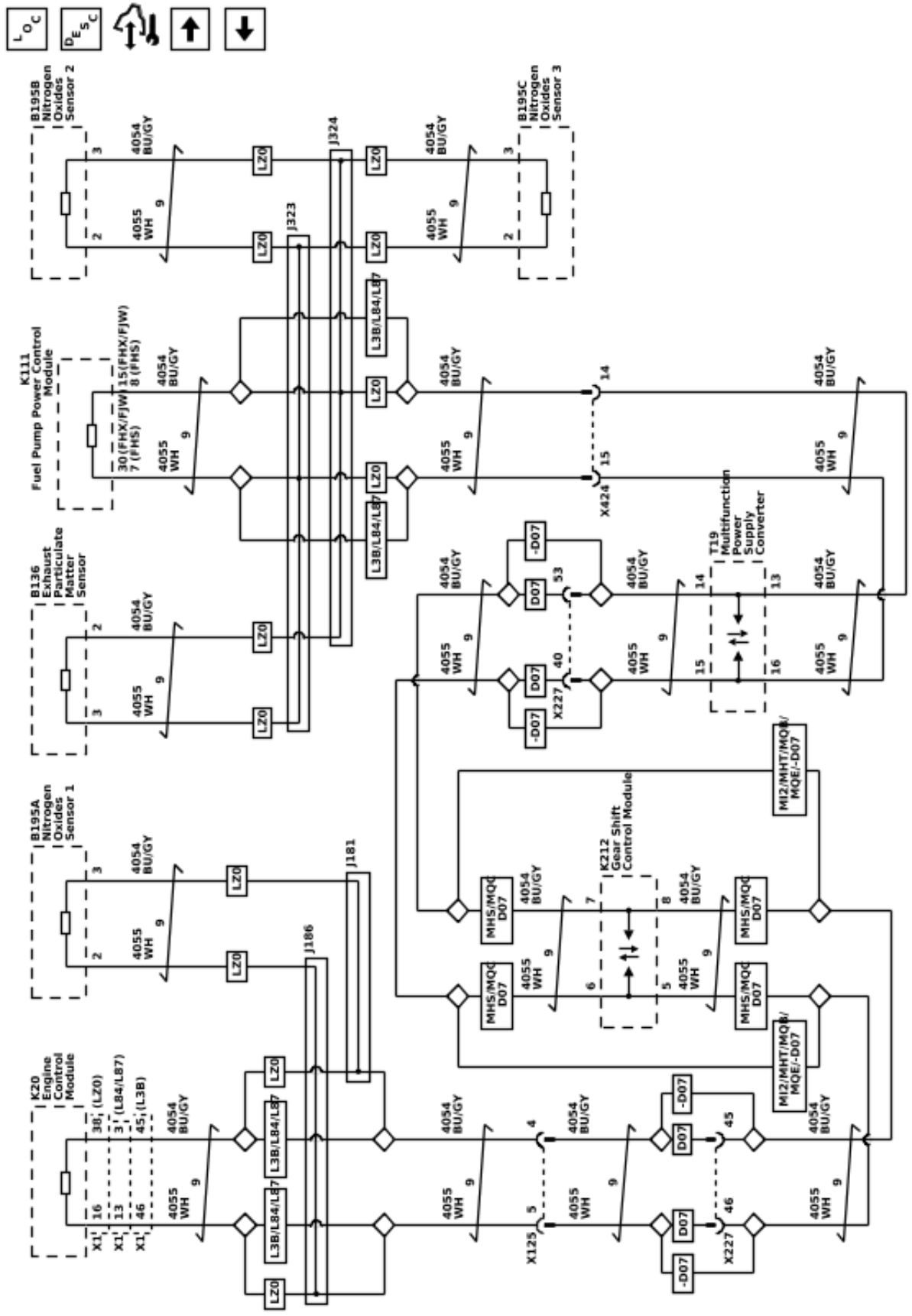

Data Communication Schematics (Powertrain CAN Enable)

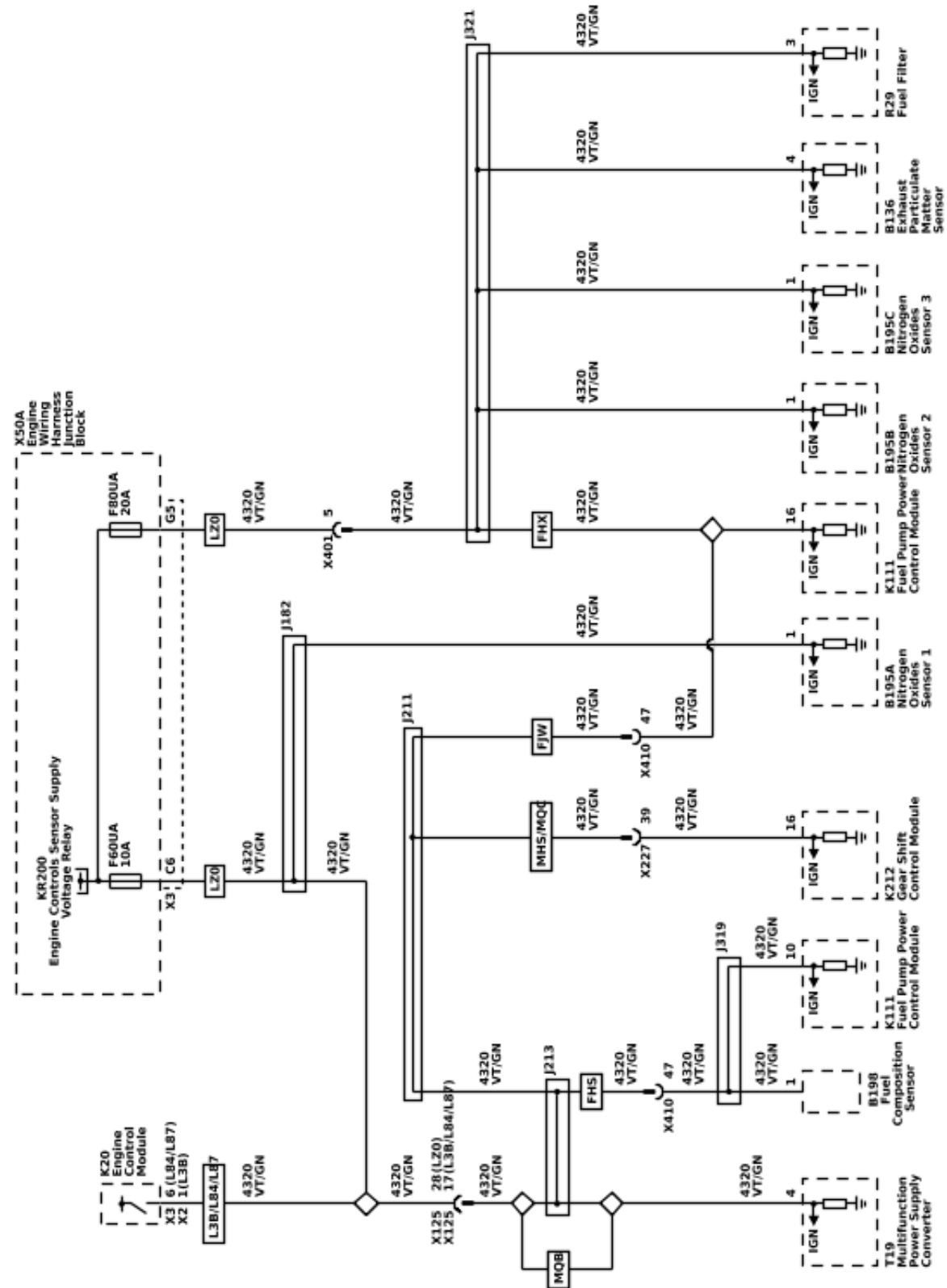

Data Communication Schematics (Body Control Module Local Interconnect Network LIN Buses 2, 3, and 4)

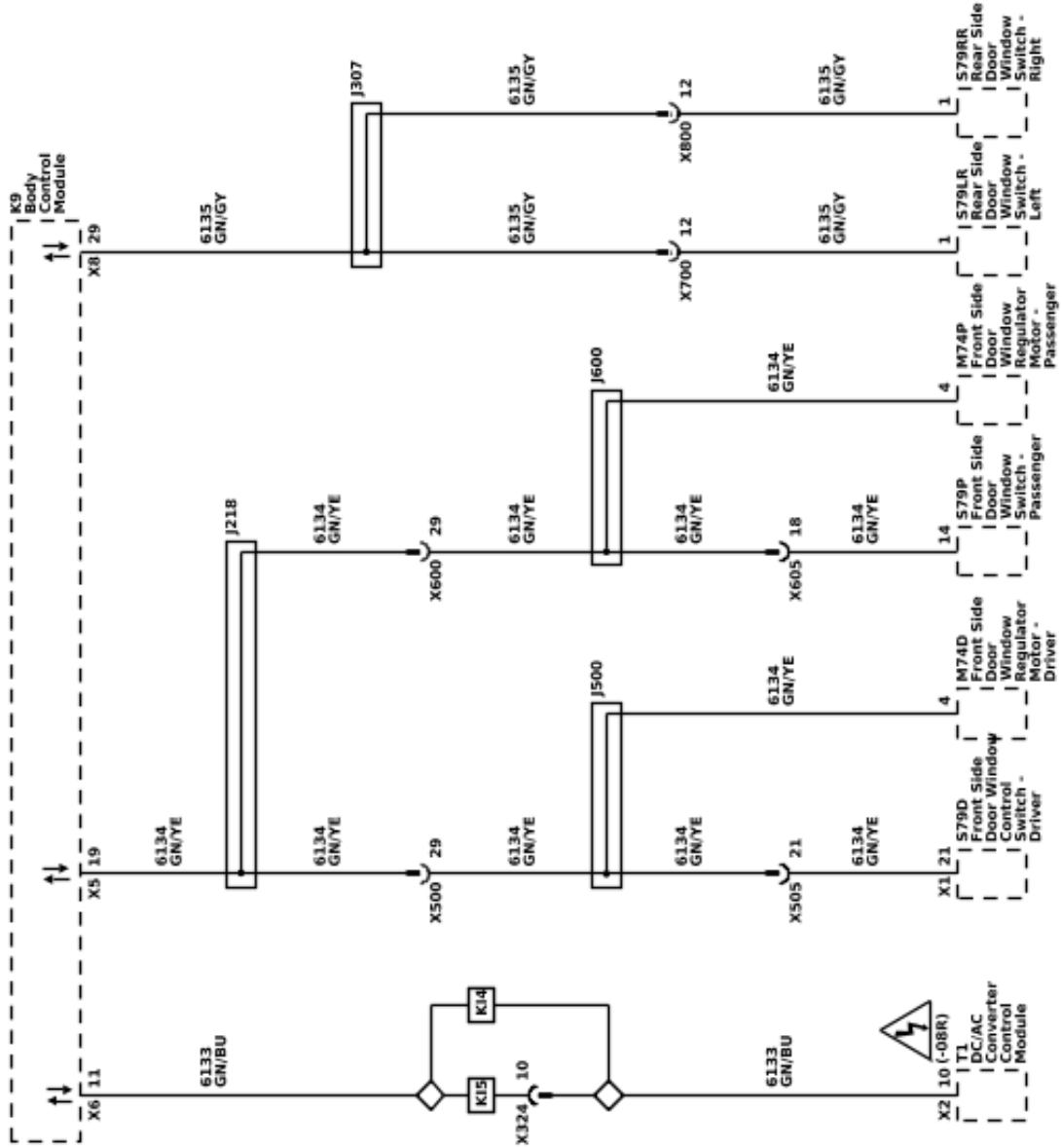

Data Communication Schematics (Body Control Module Local Interconnect Network LIN Buses 5, 6, and 8)

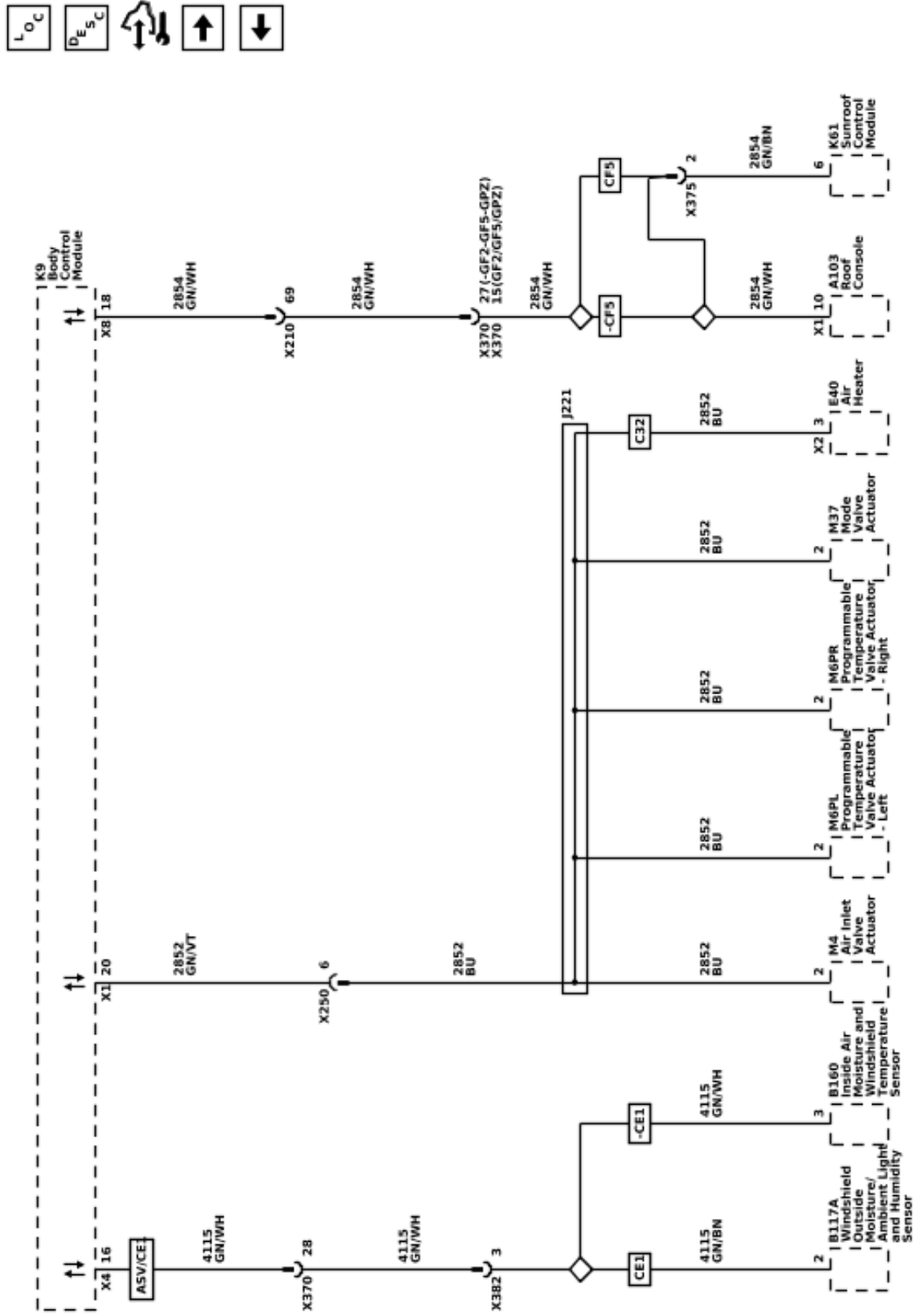

6278929



Data Communication Schematics (Body Control Module Local Interconnect Network LIN Buses 9, 11, 12, and 16)

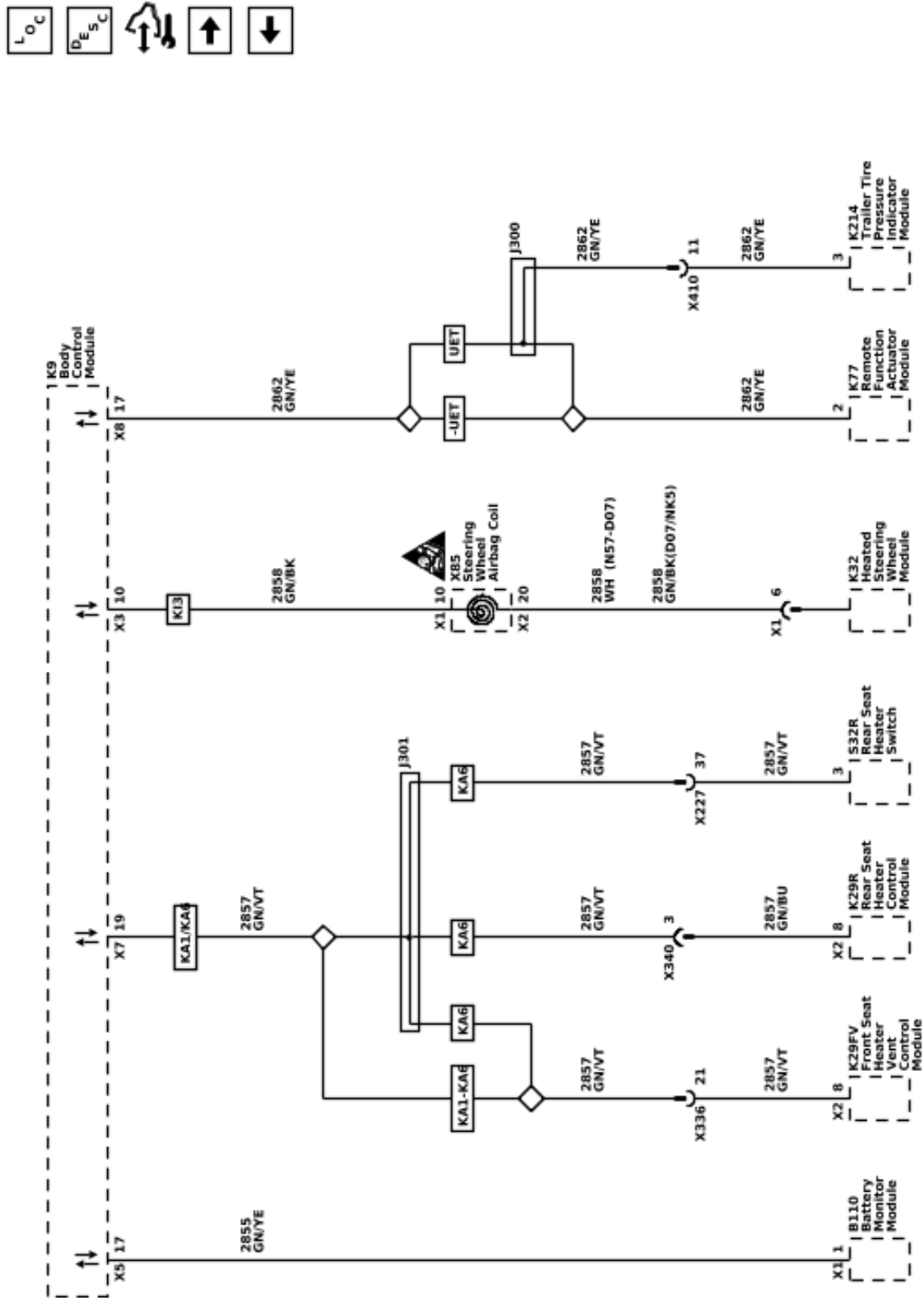

Data Communication Schematics (Brake System Control Module Local Interconnect Network LIN Busses)

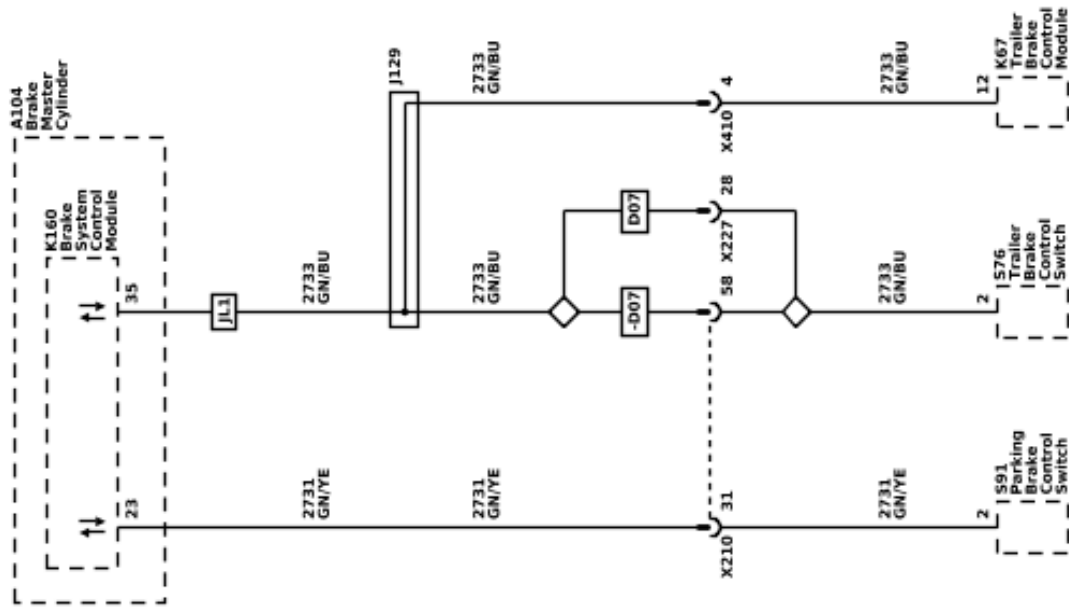

Data Communication Schematics (Engine Control Module Local Interconnect Network LIN Buses)

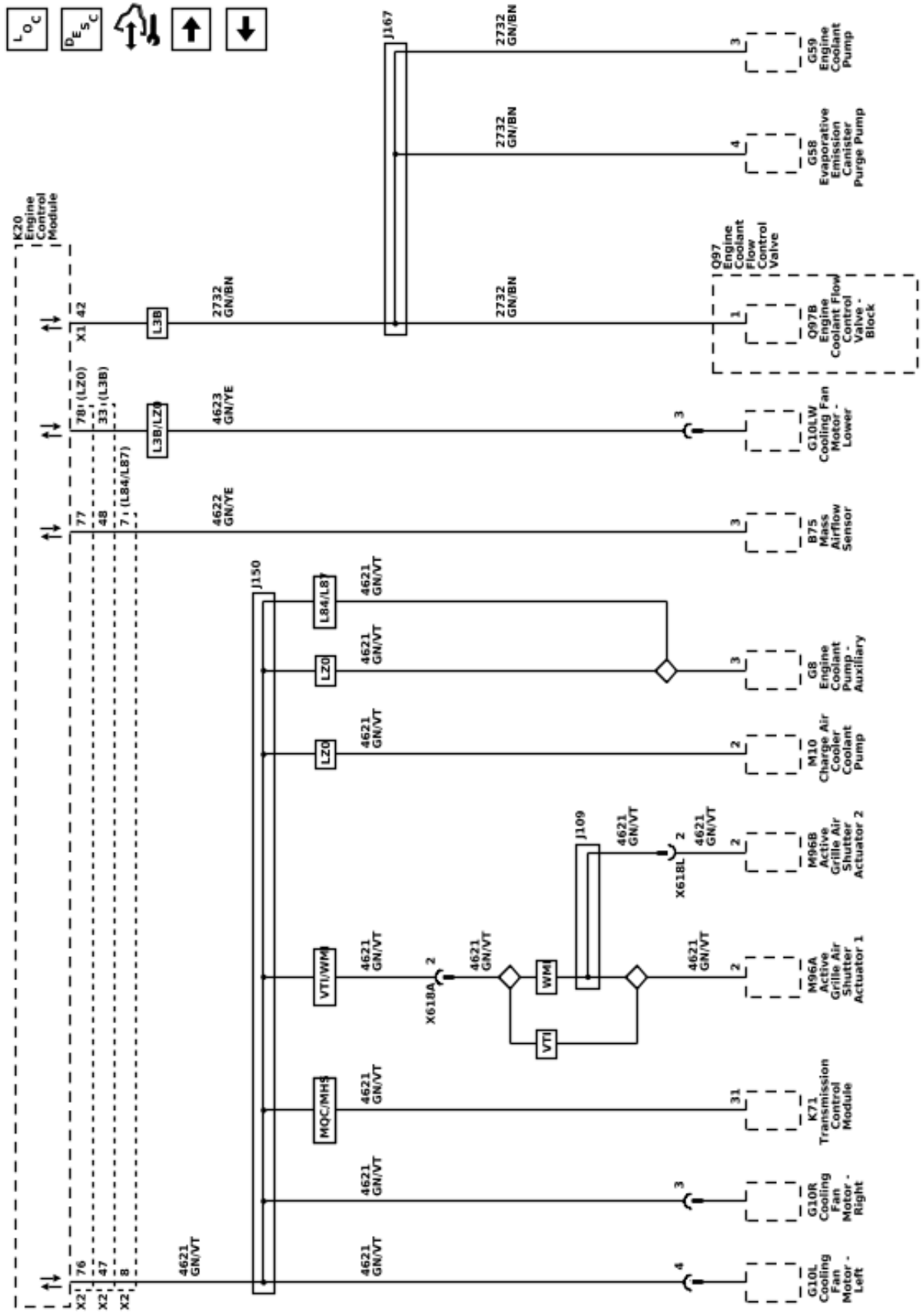

6278932

Data Communication Schematics (Image Processing Module, Instrument Panel Cluster, and Seat Memory Module Local Interconnect Network (LIN) Busses)

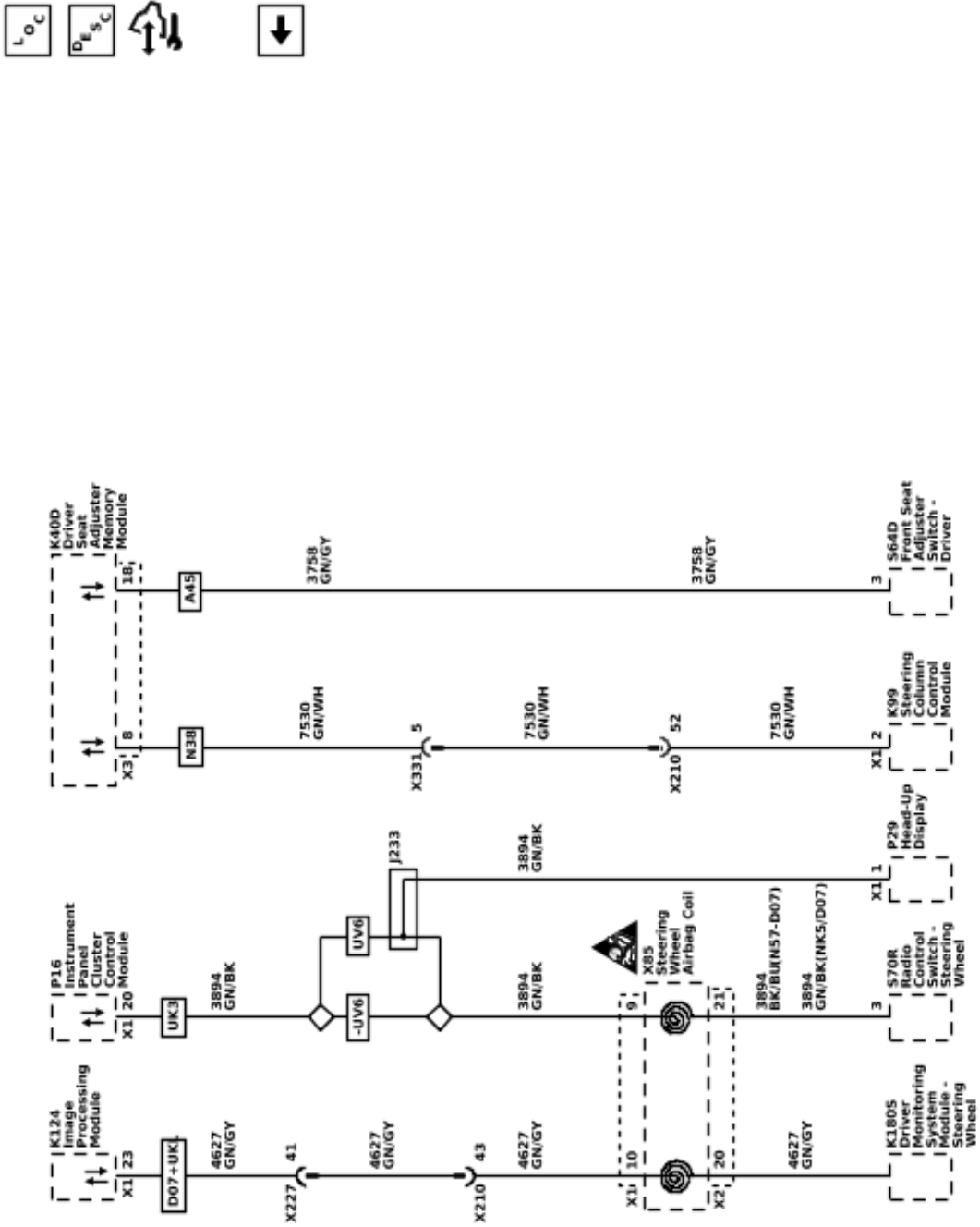

Data Communication Schematics (Ethernet Bus)

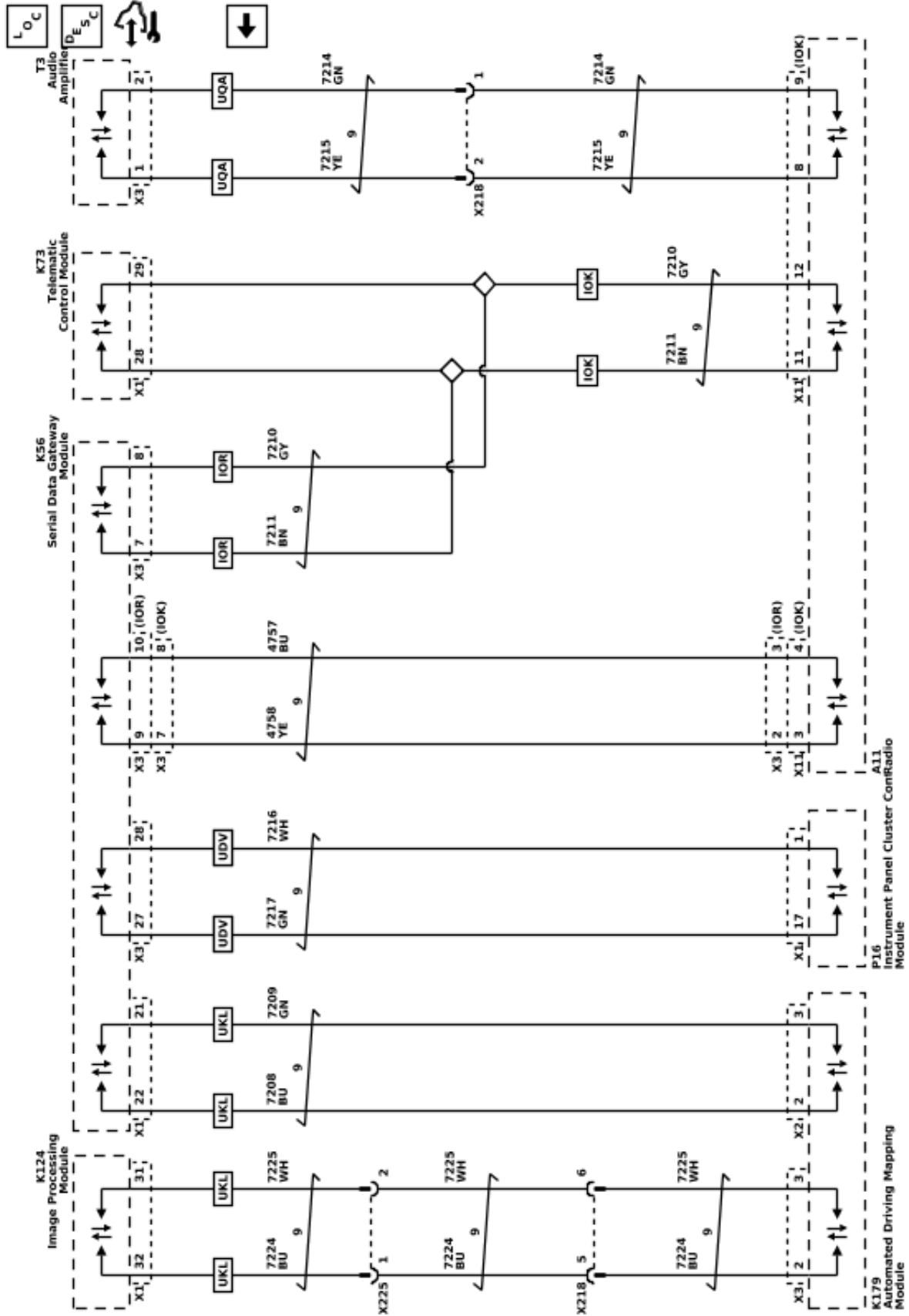

Body Control System Schematics (Power, Ground, and Subsystem References - 1 of 3)

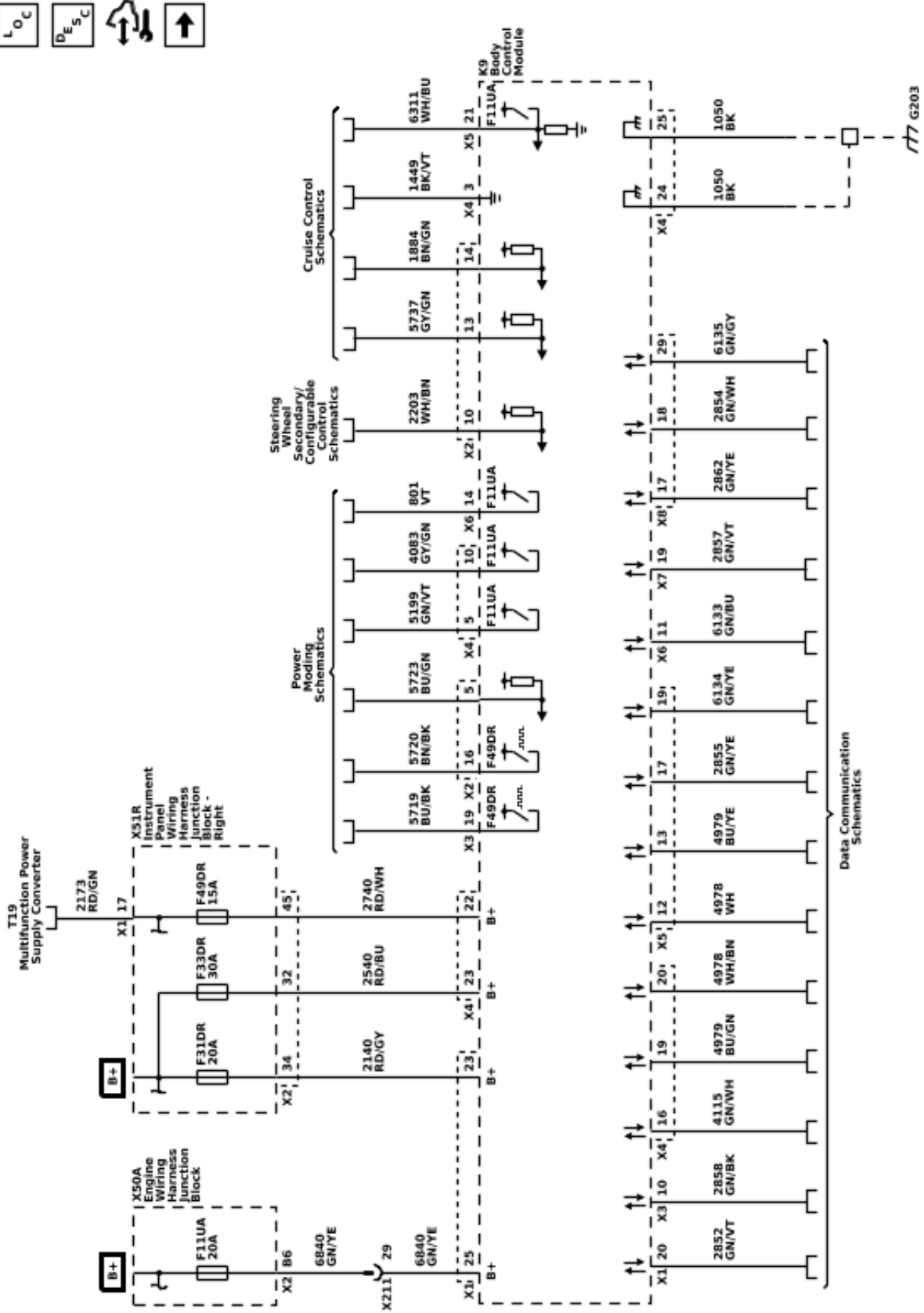
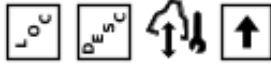

Body Control System Schematics (Subsystem References - 2 of 3)

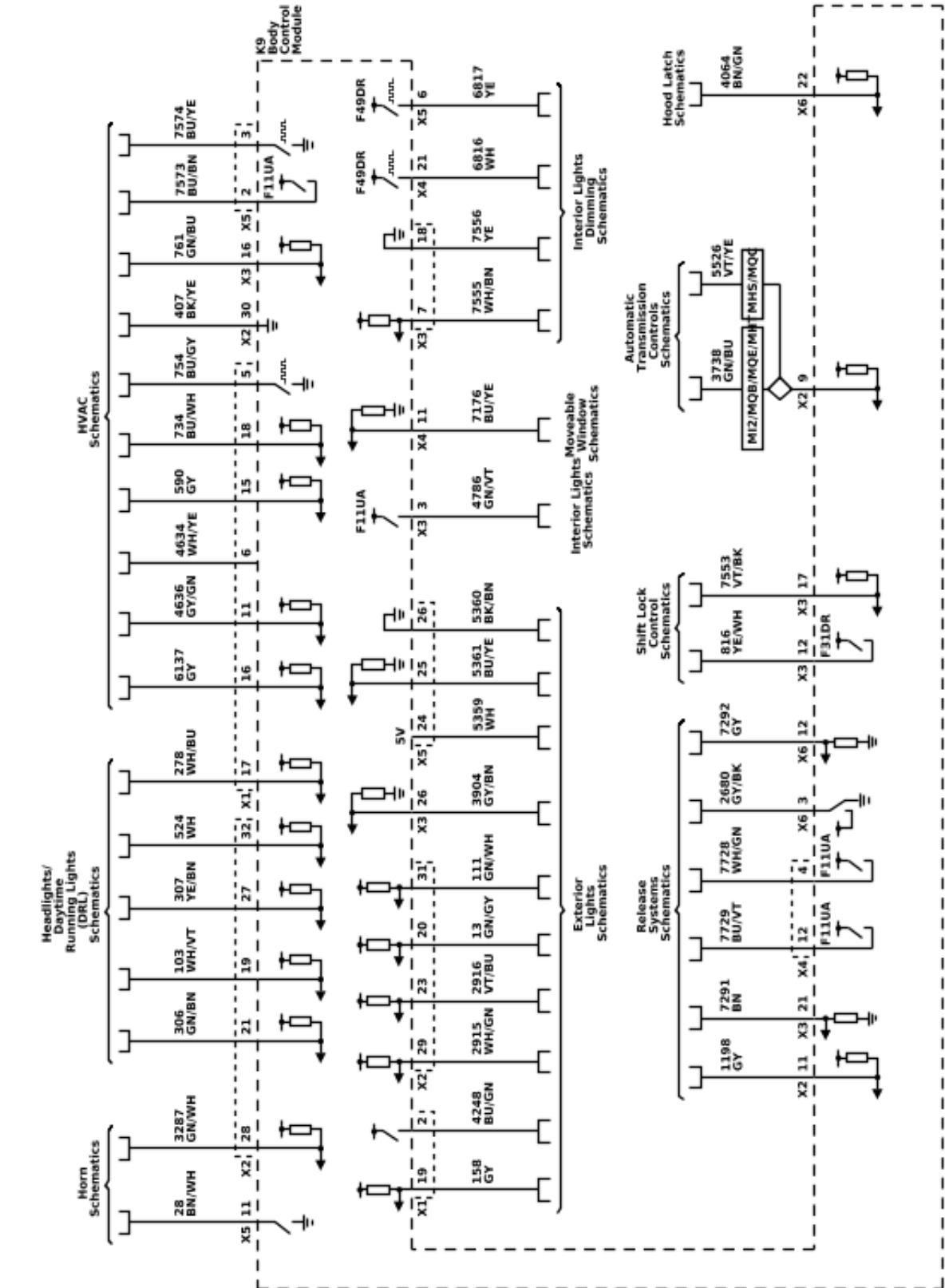

Body Control System Schematics (Subsystem References - 3 of 3)

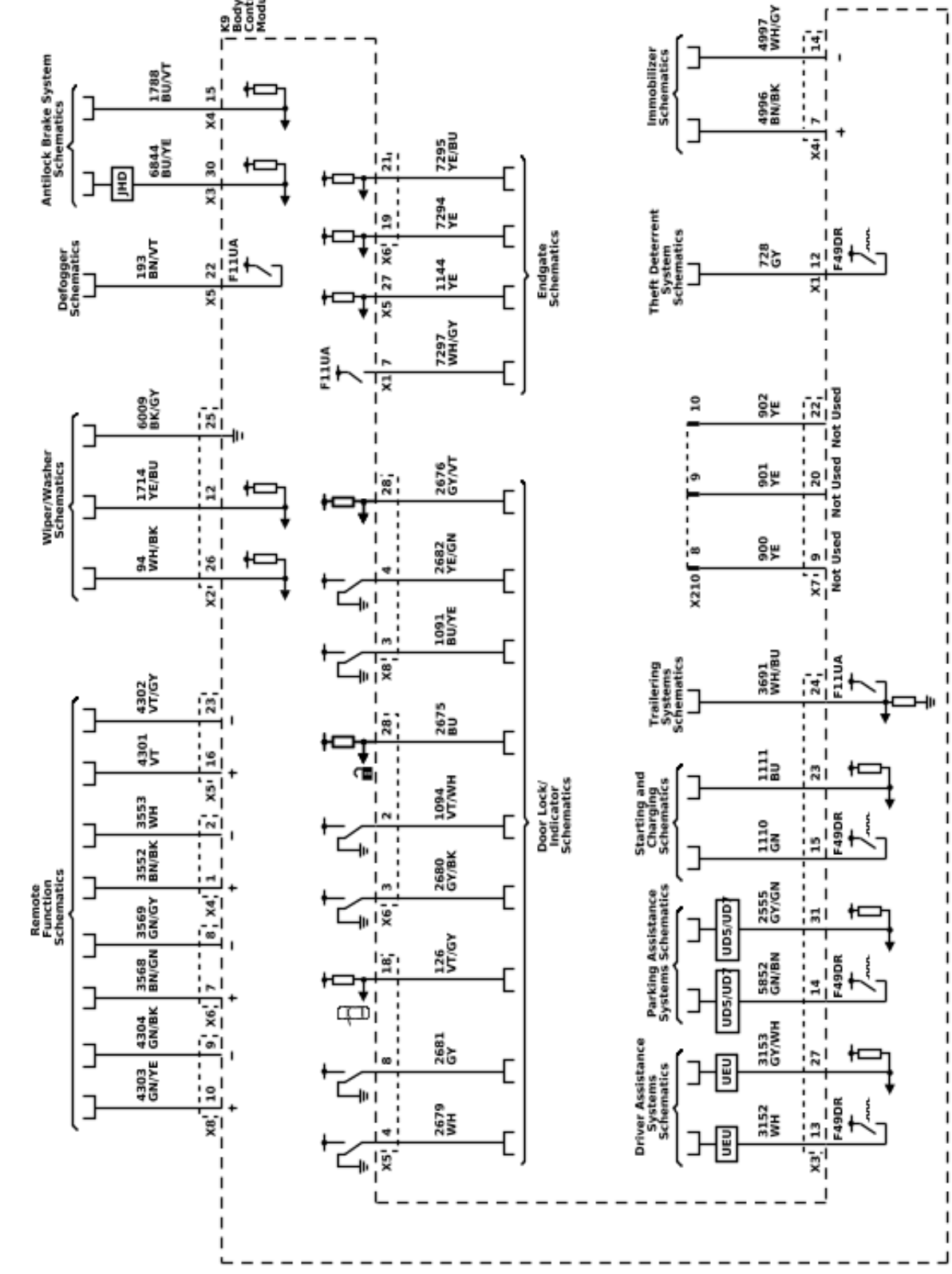

6278937



## Description and Operation

### Data Link Communications

### Description and Operation

**Note:** This is an overview of different serial data buses used by control modules to communicate with each others. Use [Data Communication Schematics on page 6-4](#) to find out which serial data buses are configured for a specific vehicle.

### Data Link Communications Overview

There are many components in a vehicle that rely on information from other sources, transmit information to other sources, or both. Serial data communication networks provide a reliable, cost effective, way for various components of the vehicle to “talk” to one another and share information.

General Motors uses a number of different communication buses to insure the timely and efficient exchange of information between control modules. When compared to each other, some of these buses are different in nature as far as speed, signal characteristics, and behavior.

On the other hand, when other buses are compared to each other they have similar characteristics and simply operate in parallel. In this case they are used to group together components which have high interaction. Examples are the Controller Area Network (CAN), private CAN, and LIN buses. This allows them to communicate with each other on a bus with reduced message congestion insuring faster and the more timely exchange of information than if all vehicle control modules were on a single bus.

The majority of information that exists within a given network generally stays local; however some information will have to be shared on other networks. Control modules designated as Gateway’s perform the function of transferring information between the various buses. A Gateway module is connected to at least 2 buses and will interact with each network according to its message strategy and transmission models.

CAN provides the capability for a receiving control module to monitor message transmissions from other control modules in order to determine if messages of interest are not being received. The primary purpose is to allow reasonable default values to be substituted for the information no longer being received. Additionally, a control module may set a Diagnostic Trouble Code (DTC) to indicate that the control module it is expecting information from is no longer communicating.

### K9 Body Control Module (BCM)

The body control system consists of the K9 Body Control Module, communications, and various input and outputs. Some inputs, outputs and messages require other control modules to interact with the K9 Body Control Module. The K9 Body Control Module also has discrete input and output terminals to control the vehicle’s body functions. The K9 Body Control Module is wired to CAN bus and multiple Local Interconnect Network (LIN) buses and acts as a gateway between them.

The various K9 Body Control Module input and output circuits are illustrated in the corresponding functional areas on the K9 Body Control Module electrical schematics. Refer to the [Body Control System Schematics on page 6-24](#) for more detailed information.

### K56 Serial Data Gateway Module

The K56 Serial Data Gateway Module gates messages between the CAN networks described in the Controller Area Network (CAN) Bus Description section below. The K56 Serial Data Gateway Module needs to know what CAN control modules are present on a given vehicle in order to enable/disable loss of communication DTCs and to know what CAN control modules to track for their communication status. The K56 Serial Data Gateway Module has the ability to learn the diagnostic addresses list of CAN control modules to identify what CAN control modules are equipped on the vehicle and what CAN buses they are on. If the K56 Serial Data Gateway Module is replaced, this learn/verification process will have to be done again through K56 Serial Data Gateway Module programming and setup procedure in SPS. This learn process will not cause any previously learned contents to be forgotten/overwritten. If the learn process is not done on a new K56 Serial Data Gateway Module, DTC U1977 will be set until the learn procedure is executed. If the learn is invalid due to control module internal malfunction or a K56 Serial Data Gateway Module swap, DTC U3000 42 or DTC U3002 56 will be set. If any of these DTCs sets, the K56 Serial Data Gateway Module will enable loss of communication for all CAN control modules. This will result in loss of communication DTCs being set against CAN control modules that are not equipped on the vehicle.

A fault can be localized by monitoring the normal mode messages on a CAN bus. The K56 Serial Data Gateway Module will monitor one signal per CAN control module per CAN bus to determine control module status. When a signal times out, a loss of communication event will be started.

### Controller Area Network (CAN) Bus Description

The CAN buses are used where data needs to be exchanged at a high enough rate to minimize the delay between the occurrence of a change in sensor value and the reception of this information by a control device using the information to adjust vehicle system performance.

Each CAN serial data network consists of two twisted wires. One signal circuit is identified as CAN-High and the other signal circuit is identified as CAN-Low. At each end of the data bus there is a 120 Ω termination resistor between the CAN-High and CAN-Low circuits. Most CAN control modules have an internal resistance of 4.950K Ω. There may be one or two CAN control modules that have a higher internal resistance like the K60 Column Lock Module which has an internal resistance of 77.4K Ω. The internal resistance of CAN control modules causes lower terminating resistor reading when splitting the CAN network to check for faults. The more CAN control modules on the network the lower the terminating resistor will read.

The data to be transmitted over a CAN bus is represented by the voltage difference between the CAN-High signal voltage and the CAN-Low signal voltage. Data symbols (1's and 0's) are transmitted sequentially at the following rate:

- CAN 1 (circuits 4986 & 4987) = 500 Kbit/s
- CAN 2 (circuits 4978 & 4979) = 2 Mbit/s
- CAN 3 (circuits 4976 & 4977) = 500 Kbit/s
- CAN 4 (circuits 4100 & 4101) = 500 Kbit/s
- CAN 5 (circuits 4984 & 4985) = 500 Kbit/s
- CAN 6 (circuits 4980 & 4981) = 5 Mbit/s
- CAN 7 (circuits 4982 & 4983) = 5 Mbit/s
- CAN 8 (circuits 4104 & 4105) = 2 Mbit/s
- CAN 9 (circuits 4102 & 4103) = 2 Mbit/s

When the two wire bus is at rest the CAN-High and CAN-Low signal circuits are not being driven and this represents a logic "1". In this state both signal circuits are at the same voltage of 2.5 V. The differential voltage is approximately 0 V.

When a logic "0" is to be transmitted, the CAN-High signal circuit is driven higher to about 3.5 V and the CAN-Low circuit is driven lower to about 1.5 V. The differential voltage becomes approximately 2.0 (+/- 0.5) V.

The CAN 1, CAN 2, CAN 3, CAN 4, CAN 5, CAN 8, and CAN 9 buses are used to communicate between the K56 Serial Data Gateway Module and other CAN control modules.

The CAN 8, and CAN 9 buses are reserved for the following systems:

- The CAN 8 bus is reserved for most control modules and sensors related to active safety system, if applicable.
- The CAN 9 bus is reserved for most control modules and sensors related to Hybrid/EV system, if applicable.

The following CAN buses are between the X84 Data Link Connector and the K56 Serial Data Gateway Module:

- The CAN 6 bus is used for CAN diagnostics and programming.
- The CAN 7 bus is used for programming by assembly plant only.
- The Private Presentation CAN 1 bus (circuits 2577 & 2578) is used by Engineering to observe data communications on CAN buses not directly accessible at the X84 Data Link Connector. It requires special security access and will not be used in a service environment.
- The Private Presentation CAN 2 bus (circuits 2579 & 2580) is used by Engineering to observe data communications on CAN buses not directly accessible at the X84 Data Link Connector. It requires special security access and will not be used in a service environment.

### Private Powertrain CAN Bus Description

The Private Powertrain CAN bus (circuits 4054 & 4055) is reserved for Powertrain components. It has a transmission rate of 500 Kbit/s. Sometimes

communication is required between the Private Powertrain CAN bus and another CAN bus. This is accomplished by using the K20 Engine Control Module (for gas vehicles) or K16 Battery Energy Control Module (for electric vehicles) as the Gateway module. Since the Private Powertrain CAN bus and other CAN buses operate in the same manner, the diagnostics for each are similar.

### Local Interconnect Network (LIN) Bus Description

The LIN Bus consists of a single wire with a transmission rate of 10.417 Kbit/s. This bus is used to exchange information between a master control module and other smart devices which provide supporting functionality. This type of configuration does not require the capacity or speed of a CAN bus and is thus relatively simpler.

The data symbols (1's and 0's) to be transmitted are represented by different voltage levels on the communication bus. When the LIN Bus is at rest and is not being driven, the signal is in a high voltage state of approximately  $V_{batt}$ . This represents a logic "1". When a logic "0" is to be transmitted, the signal voltage is driven low to about ground (0.0 V).

### Ethernet Bus Description

Ethernet is a data communication technology that uses a single twisted copper pair of wires at speeds of 100 Mbit/s and 1000 Mbit/s. The Ethernet system uses point-to-point communication that is connected via an Ethernet switch [Module <--> Switch <--> Module]. The Ethernet bus does not use terminating resistors.

The K56 Serial Data Gateway Module and the A11 Radio have an Ethernet switch that connects to other Ethernet modules. The K56 Serial Data Gateway Module and the A11 Radio communicate with other devices and systems in the vehicle via CAN and LIN buses. Diagnostic Trouble Codes will be read on CAN to diagnose Ethernet, LIN and system faults.

**Note:** Ethernet harness failures should only be repaired using an appropriate kit to perform de-pin/ re-pin overlays or in cases where the wiring harness repair kits are not available, the entire harness should be replaced. No crimps or splicing should be performed on the Ethernet wiring harness.

#### Ethernet 1

Ethernet bus 1 consists of 2 twisted pair of wires [1 pair for Ethernet bus 1R (circuits 4972 & 4973) and 1 pair for Ethernet bus 1T (circuits 4974 & 4975)]. It is connected between X84 Data Link Connector (DLC) and K56 Serial Data Gateway Module. This bus is used for diagnostics and service programming of control modules using Ethernet instead of CAN. The K56 Serial Data Gateway Module will convert Ethernet serial data to CAN as necessary, and vice versa. There is an Ethernet enable circuit (circuit 7207) which can be used to wake up the K56 Serial Data Gateway Module for Ethernet diagnostic and programming.

#### Ethernet 2

Ethernet bus 2 (circuits 4757 & 4758) is for connection between the A11 Radio and the K56 Serial Data Gateway Module.

**Ethernet 3**

Ethernet bus 3 (circuits 7208 & 7209) is for connection between the K56 Serial Data Gateway Module and K179 Automated Driving Mapping Module.

**Ethernet 4**

Ethernet bus 4 (circuits 7210 & 7211) is for connection between the following control modules:

- K56 Serial Data Gateway Module and K73 Communication Interface Module for vehicles equipped with IOR radio.
- A11 Radio and K73 Communication Interface Module for vehicles equipped with other radios.

**Ethernet 5**

Ethernet bus 5 (circuits 7212 & 7213) is for connection between the A11 Radio and P22F Video Display - Right Front Seat Back.

**Ethernet 6**

Ethernet bus 6 (circuits 7214 & 7215) is for connection between the A11 Radio and T3 Audio Amplifier.

**Ethernet 7**

Ethernet bus 7 (circuits 7216 & 7217) is for connection between the K56 Serial Data Gateway Module and P16 Instrument Panel Cluster Control Module or K190 Off-Board Charger Control Module.

**Ethernet 11**

Ethernet bus 11 (circuits 7224 & 7225) is for connection between the K124 Image Processing Module and K179 Automated Driving Mapping Module.

**Ethernet 14**

Ethernet bus 14 (circuits 7230 & 7231) is for connection between the A11 Radio and P29 Head-Up Display.

**Ethernet 15**

Ethernet bus 15 (circuits 7232 & 7233) is for connection between the K56 Serial Data Gateway Module, K161 Vehicle Performance Data Recorder, and P22F Video Display - Passenger Seat Back.

**X84 Data Link Connector (DLC)**

The X84 Data Link Connector is a standardized 16-cavity connector. Connector design and location is dictated by an industry wide standard, and is required to provide the following:

- Terminal 1: CAN Bus 7 Serial Data [+]
- Terminal 2: Private Presentation CAN Bus 1 Serial Data [+]
- Terminal 3: Ethernet Bus 1R [+]
- Terminal 4: Scan tool power ground
- Terminal 5: Common signal ground
- Terminal 6: CAN Bus 6 Serial Data [+]
- Terminal 7: Private Presentation CAN Bus 2 Serial Data [+]
- Terminal 8: Ethernet Bus 1 Enable Signal
- Terminal 9: CAN Bus 7 Serial Data [-]
- Terminal 10: Private Presentation CAN Bus 1 Serial Data [-]
- Terminal 11: Ethernet Bus 1R [-]
- Terminal 12: Ethernet Bus 1T [+]

- Terminal 13: Ethernet Bus 1T [-]
- Terminal 14: CAN Bus 6 Serial Data [-]
- Terminal 15: Private Presentation CAN Bus 2 Serial Data [-]
- Terminal 16: Scan tool power, B+

**Serial Data Reference**

The scan tool communicates over the various buses on the vehicle. When a scan tool is installed on a vehicle, the scan tool will try to communicate with every control module that could be optioned into the vehicle. If an option is not installed on the vehicle, the scan tool will display No Communication for that optional control module. In order to avert misdiagnoses of No Communication with a specific control module, refer to Data Link References for a list of control modules and the buses they communicate with. Use schematics and specific vehicle build RPO codes to determine optional control modules.

# Electrical Component and Inline Harness Connector End Views

## Component Locator

### Electrical Center Identification Views

#### X50B Battery Distribution Engine Compartment Fuse Block Top View

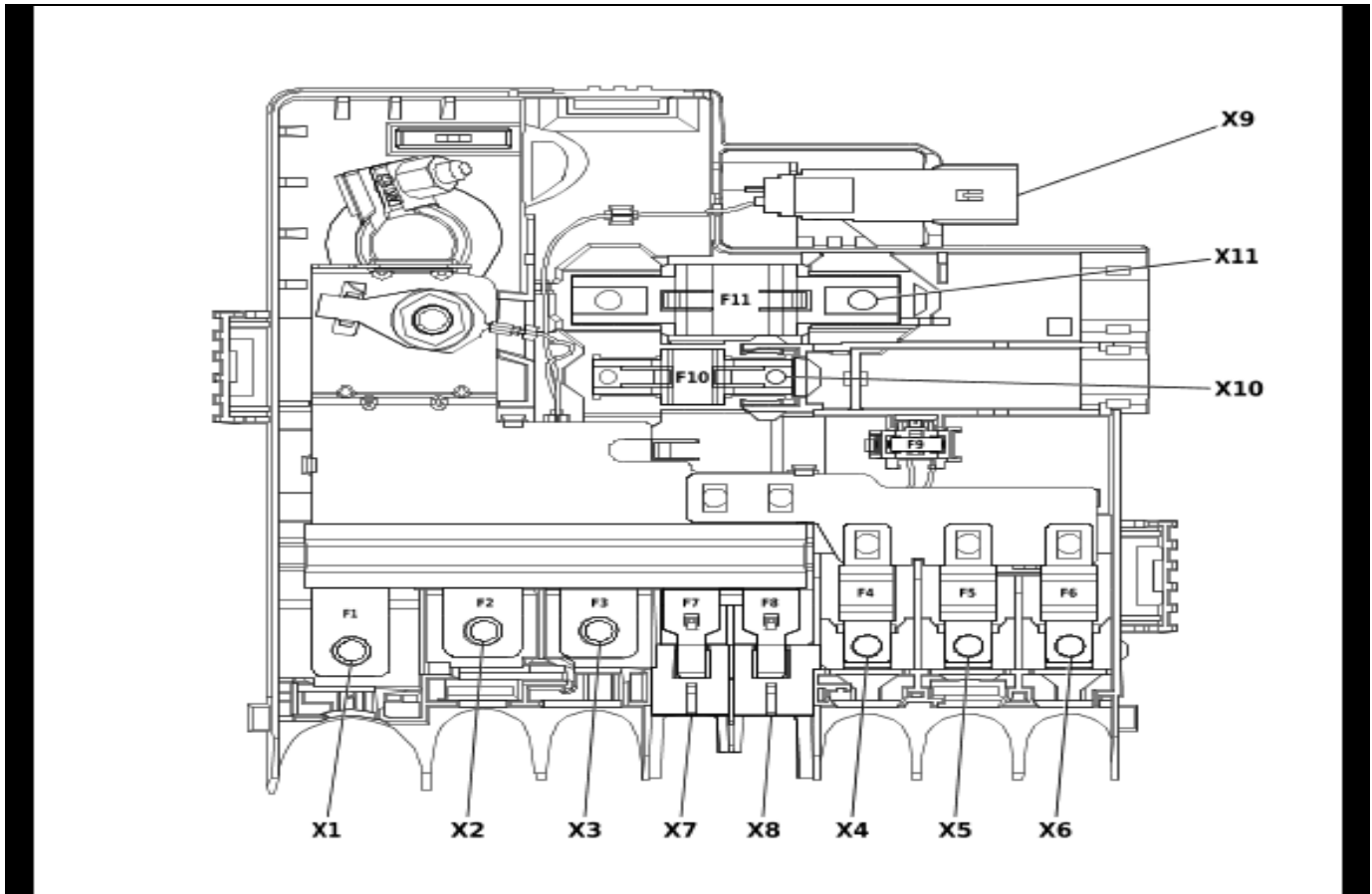

5070128

### Usage Table

No.	Device Label Name	Device Assigned Name	Rating	Description
<b>Fuses</b>				
F1	—	F1BA	250A	<ul style="list-style-type: none"> <li>G13 Generator</li> <li>X50A Engine Wiring Harness Junction Block</li> </ul>
F2	—	F2BA	250A	<ul style="list-style-type: none"> <li>K43 Power Steering Control Module</li> </ul>
F3	—	F3BA	400A	<ul style="list-style-type: none"> <li>M64 Starter Motor</li> </ul>
F4	—	F4BA	60A	<ul style="list-style-type: none"> <li>E40 Air Heater (C32)</li> </ul>
F5	—	F5BA	60A	<ul style="list-style-type: none"> <li>K20 Engine Control Module (LZ0)</li> </ul>
F6	—	F6BA	80A	<ul style="list-style-type: none"> <li>G10R Cooling Fan Motor - Right (LZ0)</li> <li>G59 Engine Coolant Pump (L3B)</li> </ul>
F7	—	F7BA	60A	<ul style="list-style-type: none"> <li>X51AX Instrument Panel Wiring Harness Junction Block - Right (9L7)</li> </ul>
F8	—	F8BA	60A	<ul style="list-style-type: none"> <li>X51R Instrument Panel Wiring Harness Junction Block - Right</li> </ul>

**Usage Table (cont'd)**

No.	Device Label Name	Device Assigned Name	Rating	Description
F9	—	F9BA	60A	<ul style="list-style-type: none"> <li>• K160 Brake System Control Module</li> <li>• X410</li> </ul>
F10	—	F10BA	5A	<ul style="list-style-type: none"> <li>• B110 Battery Sensor Module</li> </ul>

**X50B Battery Distribution Engine Compartment Fuse Block X1**

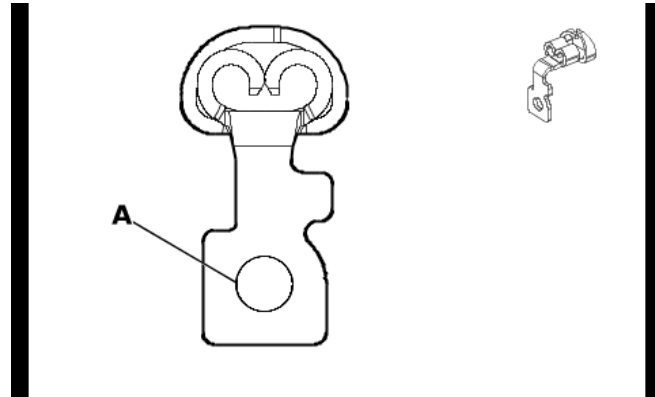

5911326

**Connector Part Information**

Harness Type: Starter Solenoid Cable  
 OEM Connector: 84386516  
 Service Connector: Service by Cable Assembly — See Part Catalog  
 Description: 1-Way Ring Terminal

**Terminal Part Information**

Terminal Type ID	Terminated Lead	Diagnostic Test Probe	Terminal Removal Tool
I	Not required	No Tool Required	No Tool Required

**X50B Battery Distribution Engine Compartment Fuse Block X1**

Pin	Size	Color	Circuit	Function	Terminal Type ID	Option
A	35	RD / BU	42	Battery Positive Voltage	I	—



**X50B Battery Distribution Engine Compartment Fuse Block X2**

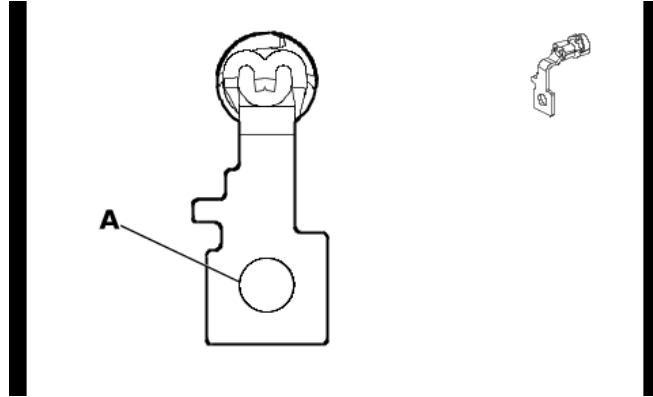

5664311

**Connector Part Information**

Harness Type: Power Steering Wiring Harness  
 OEM Connector: 84386514  
 Service Connector: Service by Cable Assembly — See Part Catalog  
 Description: 1-Way Ring Terminal

**Terminal Part Information**

Terminal Type ID	Terminated Lead	Diagnostic Test Probe	Terminal Removal Tool
I	Not required	No Tool Required	No Tool Required

**X50B Battery Distribution Engine Compartment Fuse Block X2**

Pin	Size	Color	Circuit	Function	Terminal Type ID	Option
A	25	RD / VT	3542	Battery Positive Voltage	I	—

**X50B Battery Distribution Engine Compartment Fuse Block X3**

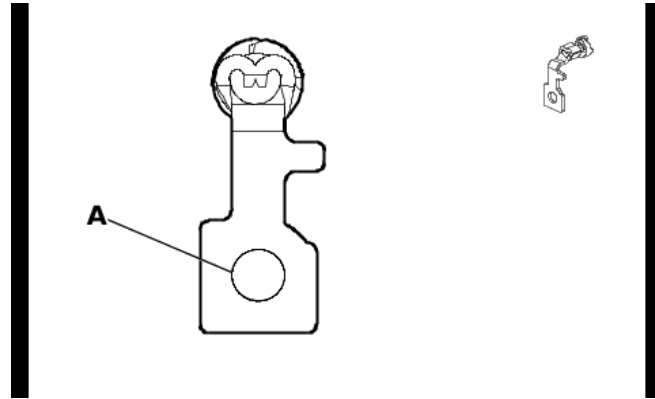

5881244

**Connector Part Information**

Harness Type: Starter Solenoid Cable  
 OEM Connector: 84386515  
 Service Connector: Service by Cable Assembly — See Part Catalog  
 Description: 1-Way Ring Terminal

**Terminal Part Information**

Terminal Type ID	Terminated Lead	Diagnostic Test Probe	Terminal Removal Tool
I	Not required	No Tool Required	No Tool Required

**X50B Battery Distribution Engine Compartment Fuse Block X3**

Pin	Size	Color	Circuit	Function	Terminal Type ID	Option
A	35	RD / YE	2	Battery Positive Voltage	I	—



**X50B Battery Distribution Engine Compartment Fuse Block X4**

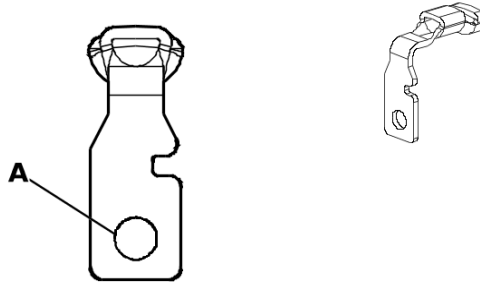

5194789

**Connector Part Information**

Harness Type: Body Wiring Harness  
 OEM Connector: 35085117  
 Service Connector: Service by Cable Assembly — See Part Catalog  
 Description: 1-Way Ring Terminal

**Terminal Part Information**

Terminal Type ID	Terminated Lead	Diagnostic Test Probe	Terminal Removal Tool
I	Not required	No Tool Required	No Tool Required

**X50B Battery Distribution Engine Compartment Fuse Block X4**

Pin	Size	Color	Circuit	Function	Terminal Type ID	Option
A	10	RD / GY	642	Battery Positive Voltage	I	—

**X50B Battery Distribution Engine Compartment Fuse Block X5**

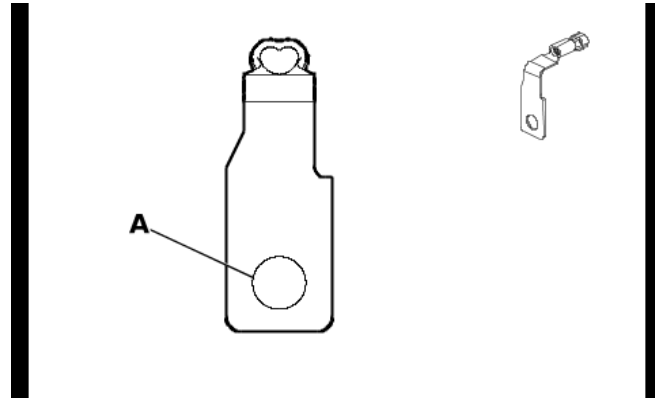

5373306

**Connector Part Information**

Harness Type: Engine Wiring Harness  
 OEM Connector: 35169508  
 Service Connector: Service by Cable Assembly — See Part Catalog  
 Description: 1-Way Ring Terminal

**Terminal Part Information**

Terminal Type ID	Terminated Lead	Diagnostic Test Probe	Terminal Removal Tool
I	Not required	No Tool Required	No Tool Required

**X50B Battery Distribution Engine Compartment Fuse Block X5**

Pin	Size	Color	Circuit	Function	Terminal Type ID	Option
A	6	BN / BU	104	Glow Plug Control	I	—

## X50B Battery Distribution Engine Compartment Fuse Block X6

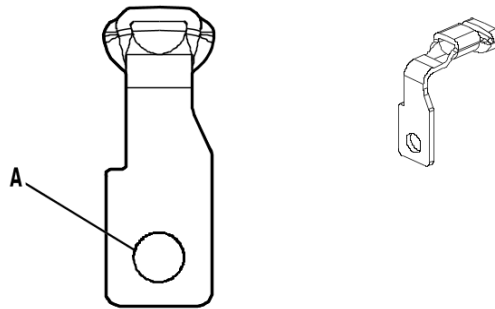

4994507

### Connector Part Information

Harness Type: Engine Wiring Harness  
 OEM Connector: 35085183  
 Service Connector: Service by Cable Assembly — See Part Catalog  
 Description: 1-Way Ring Terminal

### Terminal Part Information

Terminal Type ID	Terminated Lead	Diagnostic Test Probe	Terminal Removal Tool
I	Not required	No Tool Required	No Tool Required

### X50B Battery Distribution Engine Compartment Fuse Block X6

Pin	Size	Color	Circuit	Function	Terminal Type ID	Option
A	10	RD / BN	1742	Battery Positive Voltage	I	L3B
	8	RD / BN	1742	Battery Positive Voltage	I	LZ0

**X50B Battery Distribution Engine Compartment Fuse Block X7**

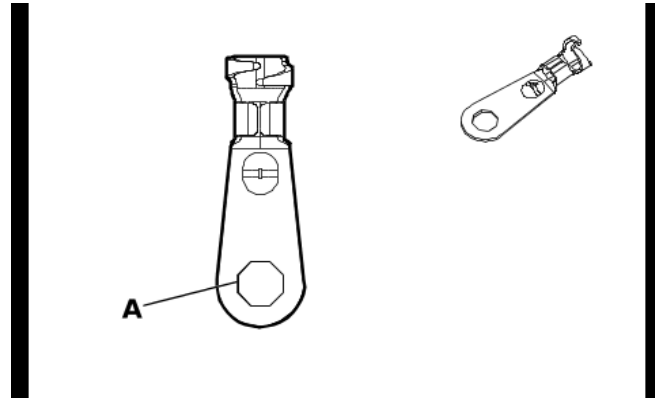

5920578

**Connector Part Information**

Harness Type: Auxiliary Fuse Block Wiring Harness  
 OEM Connector: 13624367  
 Service Connector: Service by Cable Assembly — See Part Catalog  
 Description: 1-Way Ring Terminal

**Terminal Part Information**

Terminal Type ID	Terminated Lead	Diagnostic Test Probe	Terminal Removal Tool
I	Not required	No Tool Required	No Tool Required

**X50B Battery Distribution Engine Compartment Fuse Block X7**

Pin	Size	Color	Circuit	Function	Terminal Type ID	Option
1	10	RD / VT	542	Battery Positive Voltage	I	—
A	—	—	—	Not Occupied	—	—

**X50B Battery Distribution Engine Compartment Fuse Block X8**

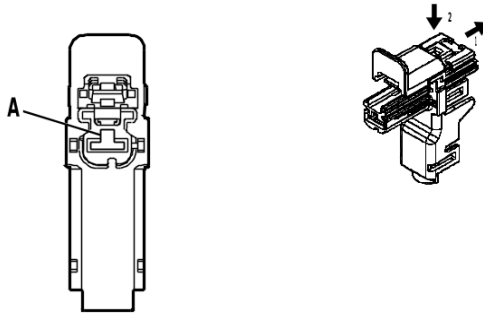

4994171

**Connector Part Information**

Harness Type: Body Wiring Harness  
 OEM Connector: 33297579  
 Service Connector: Service by Harness - See Part Catalog  
 Description: 1-Way F 6.3 Series( BU)

**Terminal Part Information**

Terminal Type ID	Terminated Lead	Diagnostic Test Probe	Terminal Removal Tool
I	Not required	J-35616-42 (RD)	No Tool Required

**X50B Battery Distribution Engine Compartment Fuse Block X8**

Pin	Size	Color	Circuit	Function	Terminal Type ID	Option
A	5	RD / YE	1442	Battery Positive Voltage	I	—

**X50B Battery Distribution Engine Compartment Fuse Block X9**

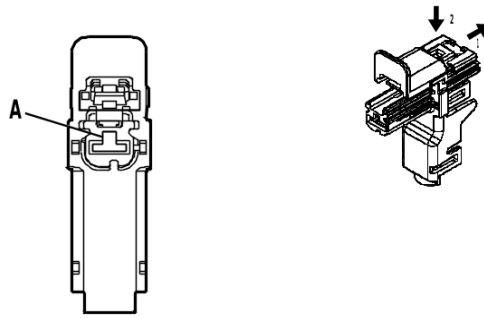

4994183

**Connector Part Information**

Harness Type: Body Wiring Harness  
 OEM Connector: 33297578  
 Service Connector: Service by Harness - See Part Catalog  
 Description: 1-Way F 6.3 Series( BK)

**Terminal Part Information**

Terminal Type ID	Terminated Lead	Diagnostic Test Probe	Terminal Removal Tool
I	Not required	J-35616-42 (RD)	No Tool Required

**X50B Battery Distribution Engine Compartment Fuse Block X9**

Pin	Size	Color	Circuit	Function	Terminal Type ID	Option
A	6	RD / WH	1642	Battery Positive Voltage	I	—

**X50B Battery Distribution Engine Compartment Fuse Block X11**

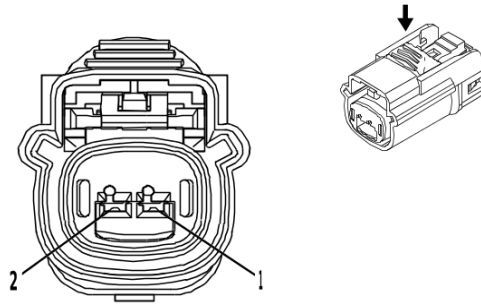

4332222

**Connector Part Information**

Harness Type: Body Wiring Harness  
 OEM Connector: 33314786  
 Service Connector: 19368124  
 Description: 2-Way F 1.5 OCS Series, Sealed( BK)

**Terminal Part Information**

Terminal Type ID	Terminated Lead	Diagnostic Test Probe	Terminal Removal Tool
I	Not required	J-35616-2A (GY)	No Tool Required

**X50B Battery Distribution Engine Compartment Fuse Block X11**

Pin	Size	Color	Circuit	Function	Terminal Type ID	Option
1	0.75	RD / YE	2340	Battery Positive Voltage	I	—
2	—	—	—	Not Occupied	—	—

X50A Engine Wiring Harness Junction Block Label

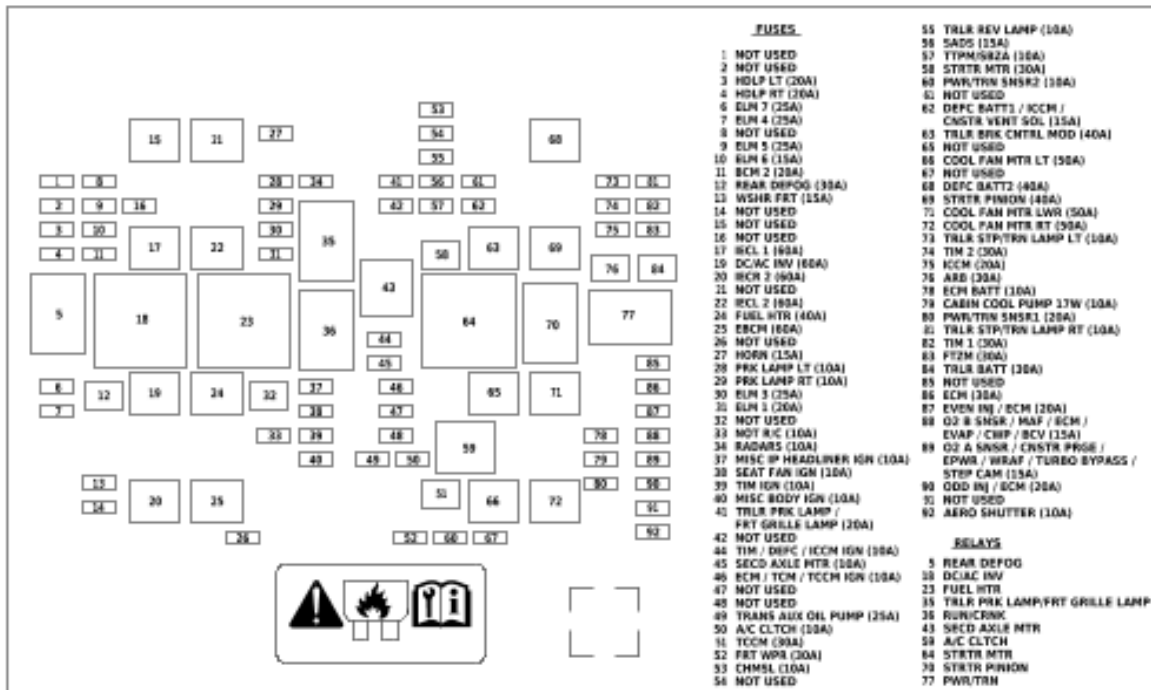



X50A Engine Wiring Harness Junction Block Top View

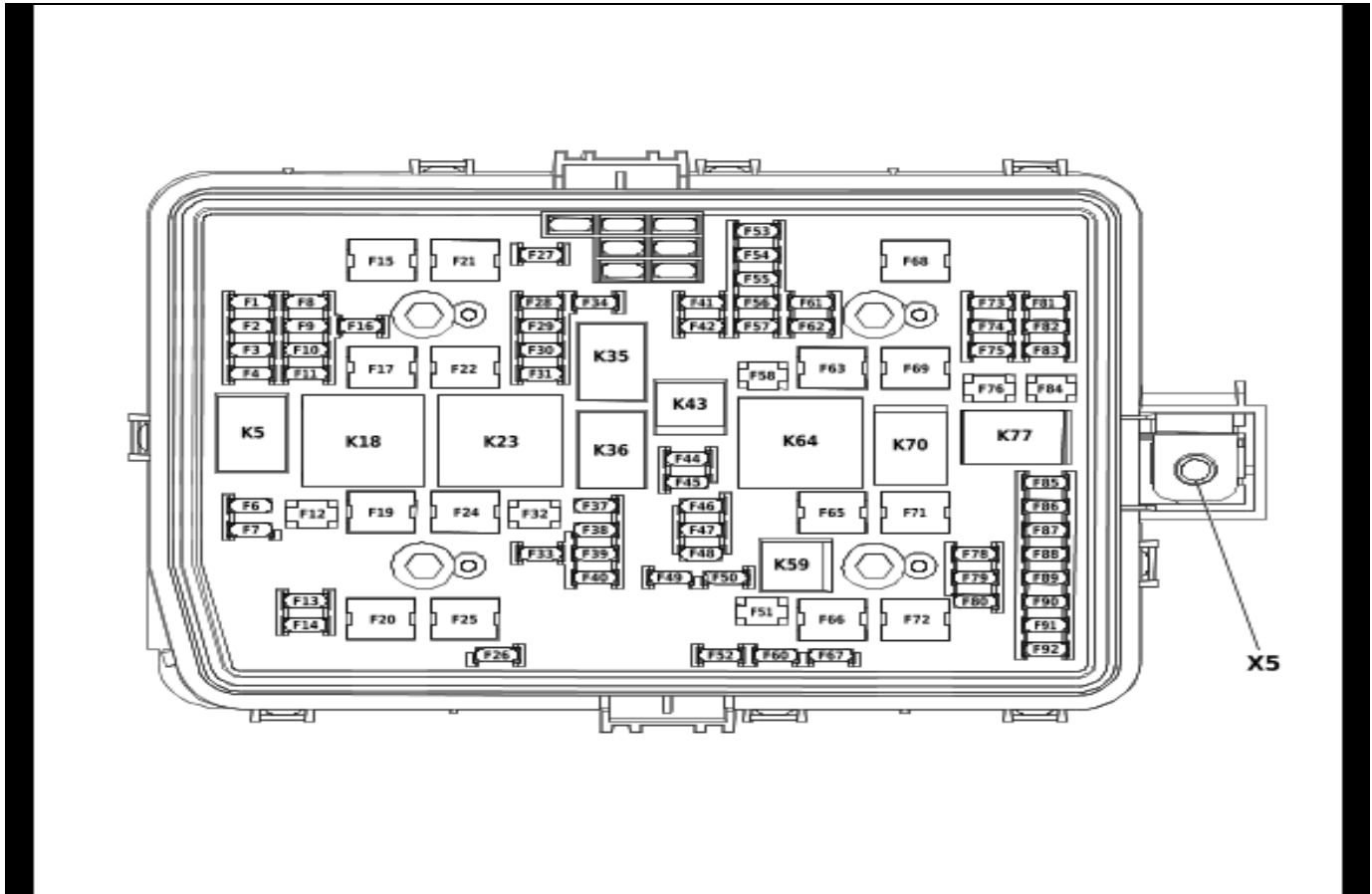

6013389

Usage Table

No.	Device Label Name	Device Assigned Name	Rating	Description
<b>Fuses</b>				
F1	NOT USED	F1UA	—	• Not Used
F2	NOT USED	F2UA	—	• Not Used
F3	HDLP LT	F3UA	20A	• E13LA Front Headlamp - Left
F4	HDLP RT	F4UA	20A	• E13RA Front Headlamp - Right
F6	ELM 7	F6UA	25A	• Not Used
F7	ELM 4	F7UA	25A	• K219 Lighting Control Module
F8	NOT USED	F8UA	—	• Not Used
F9	ELM 5	F9UA	25A	• Not Used
F10	ELM 6	F10UA	15A	• K219 Lighting Control Module
F11	BCM 2	F11UA	20A	• K9 Body Control Module
F12	REAR DEFOG	F12UA	30A	• E18 Rear Window Defogger Grid
F13	WSHR FRT	F13UA	15A	• G24 Windshield Washer Pump
F14	NOT USED	F14UA	—	• Not Used
F15	NOT USED	F15UA	—	• Not Used
F16	NOT USED	F16UA	—	• Not Used
F17	IECL 1	F17UA	60A	• X53AF Body Wiring Harness Junction Block
F19	DC/AC INV	F19UA	60A	• T1 DC/AC Converter Control Module ((K14/K15)-08R)

## 6-44 Electrical Component and Inline Harness Connector End Views

### Usage Table (cont'd)

No.	Device Label Name	Device Assigned Name	Rating	Description
F20	IECR2	F20UA	60A	• X51R Instrument Panel Wiring Harness Junction Block - Right
F21	NOT USED	F21UA	—	• Not Used
F22	IECL 2	F22UA	60A	• X53AF Body Wiring Harness Junction Block
F24	FUEL HTR	F24UA	40A	• R29 Fuel Filter (LZ0)
F25	EBCM	F25UA	60A	• K160 Brake System Control Module
F26	NOT USED	F26UA	—	• Not Used
F27	HORN	F27UA	15A	• P13 Horn
F28	PARK LAMP LT	F28UA	10A	<ul style="list-style-type: none"> <li>• A9A Outside Rearview Mirror - Driver (DPO/DQS)</li> <li>• A9B Outside Rearview Mirror - Passenger (DPO/DQS)</li> <li>• E135L Front Bumper Fascia Auxiliary Signal Lamp - Left (GRZ)</li> <li>• E135R Front Bumper Fascia Auxiliary Signal Lamp - Right (GRZ)</li> </ul>
F29	PARK LAMP RT	F29UA	10A	• Not Used
F30	ELM 3	F30UA	25A	• K219 Lighting Control Module
F31	ELM 1	F31UA	20A	• K219 Lighting Control Module
F32	NOT USED	F32UA	—	• Not Used
F33	NOT R/C	F33UA	10A	• K60 Column Lock Module
F34	RADARS	F34UA	10A	<ul style="list-style-type: none"> <li>• B233B Forward Range Radar Sensor - Long Range (UGN)</li> <li>• B233LF Short Range Radar Sensor - Left Front (UKL)</li> <li>• B233RF Short Range Radar Sensor - Right Front (UKL)</li> <li>• B233LR Short Range Radar Rear Sensor - Left (UKL)</li> <li>• B233RR Short Range Radar Rear Sensor - Right (UKL)</li> <li>• B233SL Short Range Radar Rear Side Sensor - Left (UKL)</li> <li>• B233SR Short Range Radar Rear Side Sensor - Right (UKL)</li> </ul>
F37	MISC IP HEAD-LINER IGN	F37UA	10A	<ul style="list-style-type: none"> <li>• A10 Inside Rearview Mirror</li> <li>• B117A Windshield Outside Moisture/Ambient Light and Humidity Sensor (ASV+CE1)</li> <li>• B160 Inside Air Moisture and Windshield Temperature Sensor (ASV-CE1)</li> <li>• E40 Air Heater (C32)</li> <li>• P16 Instrument Panel Cluster Control Module</li> <li>• P43 Forward Collision Alert Display ((UEU/UHX)-UV6)</li> </ul>
F38	SEAT FAN IGN	F38UA	10A	<ul style="list-style-type: none"> <li>• M73A Front Seat Back Ventilation Blower - Driver (KQV)</li> <li>• M73B Front Seat Back Ventilation Blower - Passenger (KQV)</li> <li>• M73D Front Seat Cushion Ventilation Blower - Driver (KQV)</li> <li>• M73P Front Seat Cushion Ventilation Blower - Passenger (KQV)</li> </ul>
F39	NOT USED	F39UA	10A	• K68 Trailer Lamp Control Module (UET)

**Usage Table (cont'd)**

No.	Device Label Name	Device Assigned Name	Rating	Description
F40	MISC BODY IGN	F40UA	10A	<ul style="list-style-type: none"> <li>• K36 Restraints Control Module</li> <li>• K160 Brake System Control Module</li> <li>• K212 Gear Shift Control Module (MHS/MQC)</li> <li>• K219 Lighting Control Module</li> <li>• T1 DC/AC Converter Control Module (KI4/KI5)</li> </ul>
F41	TRLR PRK LAMP / GRT GRILLE LAMP	F41UA	20A	<ul style="list-style-type: none"> <li>• X88B Tow Vehicle Electrical Receptacle (Z82-UET)</li> </ul>
F42	NOT USED	F42UA	—	<ul style="list-style-type: none"> <li>• Not Used</li> </ul>
F44	TIM / DEFC / ICCM IGN	F44UA	10A	<ul style="list-style-type: none"> <li>• K38 Chassis Control Module (G93/G94)</li> <li>• K115 Reductant Control Module (FHX)</li> </ul>
F45	SECD AXLE MTR	F45UA	10A	<ul style="list-style-type: none"> <li>• M26 Front Drive Axle Actuator (NP0/NQH)</li> </ul>
F46	ECM / TCM / TCCM IGN	F46UA	15A	<ul style="list-style-type: none"> <li>• K20 Engine Control Module</li> <li>• K69 Transfer Case Control Module (NP0/NQH)</li> <li>• K71 Transmission Control Module</li> </ul>
F47	NOT USED	F47UA	—	<ul style="list-style-type: none"> <li>• Not Used</li> </ul>
F48	NOT USED	F48UA	—	<ul style="list-style-type: none"> <li>• Not Used</li> </ul>
F49	TRANS AUX OIL PUMP	F49UA	25A	<ul style="list-style-type: none"> <li>• G5 Automatic Transmission Auxiliary Fluid Pump (MQB/MQC/MHT/MHS)</li> </ul>
F50	A/C CLTCH	F50UA	10A	<ul style="list-style-type: none"> <li>• Q2 Air Conditioning Clutch</li> </ul>
F51	TCCM	F51UA	30A	<ul style="list-style-type: none"> <li>• K69 Transfer Case Control Module (NP0/NQH)</li> </ul>
F52	FRT WPR	F52UA	30A	<ul style="list-style-type: none"> <li>• M75 Windshield Wiper Motor</li> </ul>
F53	CHMSL	F53UA	10A	<ul style="list-style-type: none"> <li>• E6A High Mount Stop and Cargo Lamp (Regular Cab)</li> </ul>
F54	NOT USED	F54UA	—	<ul style="list-style-type: none"> <li>• Not Used</li> </ul>
F55	TRLR REV LAMP	F55UA	10A	<ul style="list-style-type: none"> <li>• X88B Tow Vehicle Electrical Receptacle (Z82-UET)</li> </ul>
F56	SADS	F56UA	15A	<ul style="list-style-type: none"> <li>• K19 Suspension Control Module (Z45)</li> </ul>
F57	TTPM/SBZA	F57UA	10A	<ul style="list-style-type: none"> <li>• B218L Side Obstacle Detection Control Module - Left (UKC/UKV)</li> <li>• B218R Side Obstacle Detection Control Module - Right (UKC/UKV)</li> <li>• K214 Trailer Tire Pressure Indicator Module (UET)</li> </ul>
F58	STRTR MTR	F58UA	30A	<ul style="list-style-type: none"> <li>• M64 Starter Motor</li> </ul>
F60	PWR/TRN SNSR2	F60UA	10A	<ul style="list-style-type: none"> <li>• B195A Nitrogen Oxides Sensor 1 (LZ0)</li> <li>• K212 Gear Shift Control Module (LZ0+MQC)</li> <li>• T19 Multifunction Power Supply Converter (LZ0)</li> </ul>
F61	NOT USED	F61UA	—	<ul style="list-style-type: none"> <li>• Not Used</li> </ul>
F62	DEFC BATT1 / ICCM / CNSTR VENT SOL	F62UA	15A	<ul style="list-style-type: none"> <li>• K115 Reductant Control Module (LZ0)</li> <li>• Q13 Evaporative Emission Canister Vent Solenoid Valve (L3B/L84/L87)</li> </ul>
F63	TRLR BRK CNTRL MOD	F63UA	40A	<ul style="list-style-type: none"> <li>• K67 Trailer Brake Control Module (JL1)</li> <li>• W24 Blunt Cut - Trailer Brakes Provision (Z82-JL1)</li> </ul>
F65	NOT USED	F65UA	—	<ul style="list-style-type: none"> <li>• Not Used</li> </ul>
F66	COOL FAN MTR LT	F66UA	50A	<ul style="list-style-type: none"> <li>• G10L Cooling Fan Motor - Left</li> </ul>
F67	NOT USED	F67UA	—	<ul style="list-style-type: none"> <li>• Not Used</li> </ul>
F68	DEFC BATT2	F68UA	40A	<ul style="list-style-type: none"> <li>• K115 Reductant Control Module (LZ0)</li> </ul>
F69	STRTR PINION	F69UA	40A	<ul style="list-style-type: none"> <li>• M64 Starter Motor (L3B/L84/L87)</li> </ul>

## 6-46 Electrical Component and Inline Harness Connector End Views

### Usage Table (cont'd)

No.	Device Label Name	Device Assigned Name	Rating	Description
F71	COOL FAN MTR LWR	F71UA	50A	• G10LW Cooling Fan Motor - Lower (L3B/LZ0)
F72	COOL FAN MTR RT	F72UA	50A	• G10R Cooling Fan Motor - Right (L3B/L84/L87)
F73	TRLR STP/TRN LAMP LT	F73UA	10A	• X88B Tow Vehicle Electrical Receptacle (Z82-UET)
F74	TIM 2	F74UA	30A	• K68 Trailer Lamp Control Module (UET)
F75	NOT USED	F75UA	—	• K38 Chassis Control Module (G93/G94)
F76	ARB	F76UA	30A	• K4 Running Board Control Module (BRS)
F78	ECM BATT	F78UA	10A	• K20 Engine Control Module
F79	CABIN COOL PUMP 17W	F79UA	10A	• G8 Engine Coolant Pump - Auxiliary (L84/L87/LZ0)
F80	PWR/TRN SNSR1	F80UA	20A	<ul style="list-style-type: none"> <li>• B195B Nitrogen Oxides Sensor 2 (LZ0)</li> <li>• B195C Nitrogen Oxides Sensor 3 (LZ0)</li> <li>• B136 Exhaust Particulate Matter Sensor (LZ0)</li> <li>• K111 Fuel Pump Power Control Module (LZ0)</li> <li>• R29 Fuel Filter (LZ0)</li> </ul>
F81	TRLR STP/TRN LAMP RT	F81UA	10A	• X88B Tow Vehicle Electrical Receptacle (Z82-UET)
F82	TIM 1	F82UA	30A	• K68 Trailer Lamp Control Module (UET)
F83	FTZM	F83UA	30A	• K111 Fuel Pump Power Control Module
F84	TRLR BATT	F84UA	30A	• X88B Tow Vehicle Electrical Receptacle (Z82)
F85	NOT USED	F85UA	—	• Not Used
F86	ECM	F86UA	30A	• K20 Engine Control Module
F87	EVEN INJ / ECM	F87UA	20A	<ul style="list-style-type: none"> <li>• K20 Engine Control Module (L84/L87)</li> <li>• T8B Ignition Coil 2 (L84/L87)</li> <li>• T8D Ignition Coil 4 (L84/L87)</li> <li>• T8F Ignition Coil 6 (L84/L87)</li> <li>• T8H Ignition Coil 8 (L84/L87)</li> </ul>
F88	O2 B SNSR / MAF / ECM / EVAP / CWP / BCV	F88UA	15A	<ul style="list-style-type: none"> <li>• B52B Heated Oxygen Sensor 2 (L3B)</li> <li>• B52D Heated Oxygen Sensor - Bank 1 Sensor 2 (L84/L87)</li> <li>• B52F Heated Oxygen Sensor - Bank 2 Sensor 2 (L84/L87)</li> <li>• B75 Mass Airflow Sensor</li> <li>• G58 Evaporative Emission Canister Purge Pump (L3B)</li> <li>• K20 Engine Control Module</li> <li>• M10 Charge Air Cooler Coolant Pump (LZ0)</li> <li>• Q97B Engine Coolant Flow Control Valve - Block (L3B)</li> </ul>

**Usage Table (cont'd)**

No.	Device Label Name	Device Assigned Name	Rating	Description
F89	O2 A SNSR / CNSTR PRGE / EPWR / WRAF / TURBO BYPASS / STEP CAM	F89UA	15A	<ul style="list-style-type: none"> <li>• B52C Heated Oxygen Sensor - Bank 1 Sensor 1 (L3B/L84/L87)</li> <li>• B52E Heated Oxygen Sensor - Bank 2 Sensor 1 (L84/L87)</li> <li>• M129A Intake Camshaft Profile Actuator 1 (L3B)</li> <li>• M129B Intake Camshaft Profile Actuator 2 (L3B)</li> <li>• M129C Intake Camshaft Profile Actuator 3 (L3B)</li> <li>• M129D Intake Camshaft Profile Actuator 4 (L3B)</li> <li>• M130A Exhaust Camshaft Profile Actuator 1 (L3B)</li> <li>• M130B Exhaust Camshaft Profile Actuator 2 (L3B)</li> <li>• Q12 Evaporative Emission Canister Purge Solenoid Valve (L3B/L84/L87)</li> <li>• Q40 Turbocharger Bypass Valve Solenoid (L3B)</li> <li>• Q44 Engine Oil Pressure Control Solenoid Valve (L3B/L84/L87)</li> </ul>
F90	ODD INJ / ECM	F90UA	20A	<ul style="list-style-type: none"> <li>• K20 Engine Control Module</li> <li>• T8A Ignition Coil 1 (L3B/L84/L87)</li> <li>• T8B Ignition Coil 2 (L3B)</li> <li>• T8C Ignition Coil 3 (L3B/L84/L87)</li> <li>• T8D Ignition Coil 4 (L3B)</li> <li>• T8E Ignition Coil 5 (L84/L87)</li> <li>• T8G Ignition Coil 7 (L84/L87)</li> </ul>
F91	NOT USED	F91UA	—	<ul style="list-style-type: none"> <li>• Not Used</li> </ul>
F92	AERO SHUTTER	F92UA	10A	<ul style="list-style-type: none"> <li>• M96 Active Grille Air Shutter Actuator (VTI/WMI)</li> <li>• M96B Active Grille Air Shutter Actuator 2 (WMI)</li> </ul>
<b>Relays</b>				
K5	REAR DEFOG	KR5 Rear Window Defogger Relay	—	<ul style="list-style-type: none"> <li>• F12UA</li> </ul>
K18	DC/AC INV	KR202 Accessory AC and DC Power Control Module Relay	—	<ul style="list-style-type: none"> <li>• F19UA</li> </ul>
K23	FUEL HTR	KR22 Fuel Heater Relay	—	<ul style="list-style-type: none"> <li>• R29 Fuel Filter (LZ0)</li> </ul>
K35	TRLR PRK LAMP/ FRT GRILLE LAMP	KR53 Parking Lamp Relay	—	<ul style="list-style-type: none"> <li>• F28UA</li> <li>• F41UA</li> </ul>
K36	RUN/CRNK	KR73 Ignition Main Relay	—	<ul style="list-style-type: none"> <li>• F33UA</li> <li>• F37UA</li> <li>• F38UA</li> <li>• F39UA</li> <li>• F40UA</li> <li>• F44UA</li> <li>• F46UA</li> </ul>
K43	SECD AXLE MTR	KR203 Front Drive Axle Actuator Relay	—	<ul style="list-style-type: none"> <li>• F45UA (NP0/NQH)</li> </ul>
K59	A/C CLTCH	KR29 A/C Compressor Clutch Relay	—	<ul style="list-style-type: none"> <li>• F50UA</li> </ul>
K64	STRTR MTR	KR27 Starter Motor	—	<ul style="list-style-type: none"> <li>• M64 Starter Motor</li> </ul>
K70	STRTR PINION	KR27C Engine Re-start Relay	—	<ul style="list-style-type: none"> <li>• M64 Starter Motor (L3B/L84/L87)</li> </ul>

Usage Table (cont'd)

No.	Device Label Name	Device Assigned Name	Rating	Description
K77	PWR/TRN	KR75 Engine Controls Ignition Relay	—	<ul style="list-style-type: none"> <li>• F86UA</li> <li>• F87UA</li> <li>• F88UA</li> <li>• F89UA</li> <li>• F90UA</li> <li>• F92UA</li> <li>• KR29 Air Conditioning Compressor Relay</li> </ul>
<b>Note: Relays listed below are non-serviceable Printed Circuit Board (PCB) relays and are internal to the block.</b>				
—	—	KR3 Horn Relay	—	<ul style="list-style-type: none"> <li>• F27UA</li> </ul>
—	—	KR11 Windshield Washer Pump Relay	—	<ul style="list-style-type: none"> <li>• G24 Windshield Washer Pump</li> </ul>
—	—	KR12B Windshield Wiper Motor Relay	—	<ul style="list-style-type: none"> <li>• M75 Windshield Wiper Motor</li> </ul>
—	—	KR12C Windshield Wiper Motor Speed Control Relay	—	<ul style="list-style-type: none"> <li>• M75 Windshield Wiper Motor</li> </ul>
—	—	KR61 Trailer Backup Lamp Relay	—	<ul style="list-style-type: none"> <li>• F55UA</li> </ul>
—	—	KR63L Trailer Stop/Turn Signal Lamp Relay - Left	—	<ul style="list-style-type: none"> <li>• F73UA</li> </ul>
—	—	KR63R Trailer Stop/Turn Signal Lamp Relay - Right	—	<ul style="list-style-type: none"> <li>• F81UA</li> </ul>
—	—	KR200 Engine Controls Sensor Supply Voltage Relay	—	<ul style="list-style-type: none"> <li>• F60UA</li> <li>• F80UA</li> </ul>

X50A Engine Wiring Harness Junction Block Bottom View

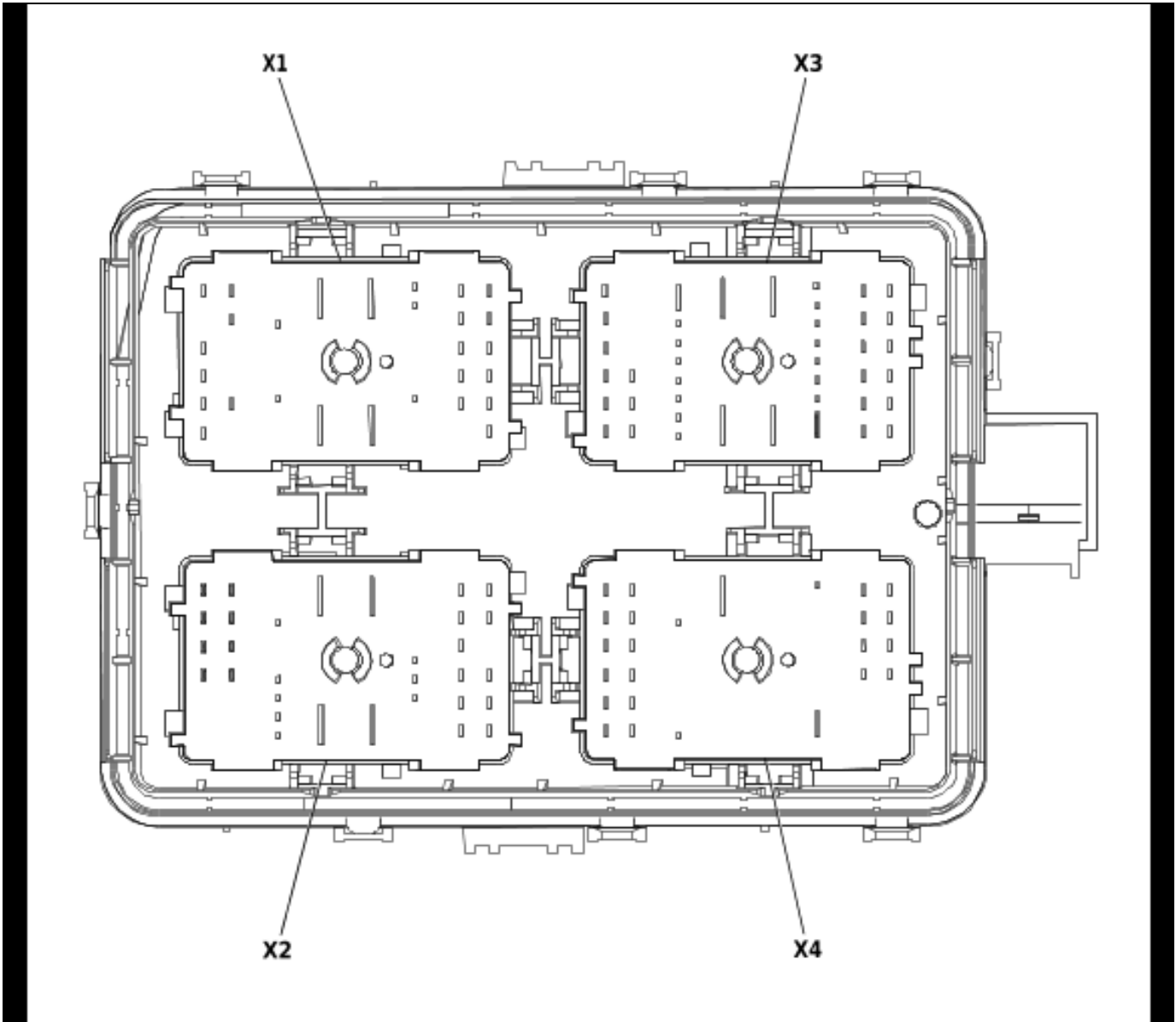

5041382

**X50A Engine Wiring Harness Junction Block X1**

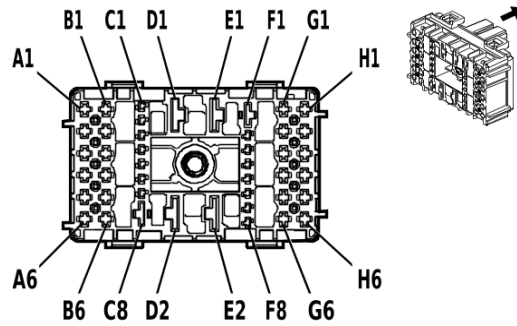

4994109

**Connector Part Information**

Harness Type: Body Wiring Harness  
 OEM Connector: 33384590  
 Service Connector: 19370824  
 Description: 44-Way F 1.5, 2.8, 6.3 CTS, 9.5 MCON-LL Series( BU)

**Terminal Part Information**

Terminal Type ID	Terminated Lead	Diagnostic Test Probe	Terminal Removal Tool
I	19369711	J-35616-14 (GN)	EL-38125-560A
II	84764079	J-35616-44 (YE)	J-38125-11A
III	84779405	J-35616-35 (VT)	J-38125-215A
IV	Not required	J-35616-22 (RD)	No Tool Required

**X50A Engine Wiring Harness Junction Block X1**

Pin	Size	Color	Circuit	Function	Terminal Type ID	Option
A1	—	—	—	Not Occupied	—	—
A2	1.5	RD / BU	540	Battery Positive Voltage	III	—
A3	0.35	BN / VT	193	Rear Defogger Relay Control	III	—
A4	0.5	BK	650	Ground	III	—
A5	0.75	GY / VT	228	Windshield Washer Pump Control	III	—
A6 - B1	—	—	—	Not Occupied	—	—
B2	2.5	BN / VT	293	Rear Defogger Grid Control	III	—
B3 - C2	—	—	—	Not Occupied	—	—
C3	0.5	WH / GN	4628	DC/AC Inverter Relay Control	I	—
C4	0.35	BN / GY	2268	Windshield Washer Relay Control	I	—
C5 - C8	—	—	—	Not Occupied	—	—
D1	5	BN / BK	4629	DC/AC Inverter Control	II	—
D2	10	RD / WH	342	Battery Positive Voltage	IV	—
E1	—	—	—	Not Occupied	—	—
E2	6	RD / WH	1040	Battery Positive Voltage	II	—
F1 - F5	—	—	—	Not Occupied	—	—
F6	0.35	WH / VT	860	Windshield Wiper Switch High Signal	I	—
F7 - G2	—	—	—	Not Occupied	—	—
G3	0.35	BU / VT	807	Ignition Off/Accessory Ignition Voltage	III	—



**X50A Engine Wiring Harness Junction Block X1 (cont'd)**

<b>Pin</b>	<b>Size</b>	<b>Color</b>	<b>Circuit</b>	<b>Function</b>	<b>Terminal Type ID</b>	<b>Option</b>
G4	0.5	GN / VT	5199	Run/Crank Relay Coil Control	III	—
G5	2	BK	150	Ground	III	—
G6	0.35	GY	91	Windshield Wiper Motor Relay Coil Control	III	—
H1	0.5	VT / BK	339	Run/Crank Ignition 1 Voltage	III	—
H2	0.75	VT / WH	1139	Run/Crank Ignition 1 Voltage	III	—
H3	0.5	VT / WH	639	Run/Crank Ignition 1 Voltage	III	—
H4	0.5	VT / WH	239	Run/Crank Ignition 1 Voltage	III	—
H5	2	WH	92	Windshield Wiper Motor High Speed Control	III	—
H6	2	YE / BN	95	Windshield Wiper Motor Low Speed Control	III	—

**X50A Engine Wiring Harness Junction Block X2**

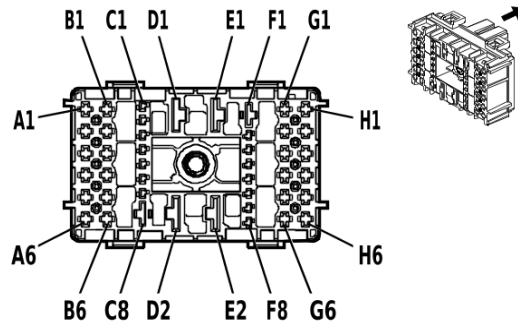

4994132

**Connector Part Information**

Harness Type: Body Wiring Harness  
 OEM Connector: 33384594  
 Service Connector: 19371174  
 Description: 44-Way F 1.5, 2.8, 6.3 CTS, 9.5 MCON-LL Series( GN)

**Terminal Part Information**

Terminal Type ID	Terminated Lead	Diagnostic Test Probe	Terminal Removal Tool
I	19369711	J-35616-14 (GN)	EL-38125-560A
II	84779405	J-35616-35 (VT)	J-38125-215A
III	Not required	J-35616-22 (RD)	No Tool Required

**X50A Engine Wiring Harness Junction Block X2**

Pin	Size	Color	Circuit	Function	Terminal Type ID	Option
A1 - A4	—	—	—	Not Occupied	—	—
A5	1.5	RD / WH	640	Battery Positive Voltage	II	—
A6	1.5	RD / YE	740	Battery Positive Voltage	II	—
B1 - B4	—	—	—	Not Occupied	—	—
B5	0.5	RD / BU	840	Battery Positive Voltage	II	—
B6	1	GN / YE	6840	Auxiliary Device 2 Switched Voltage	II	—
C1	0.35	YE / BU	318	Left Rear Trailer Stop/Turn Lamp Control	I	—
C2	0.35	GN / BN	319	Right Rear Trailer Stop/Turn Lamp Control	I	—
C3 - D1	—	—	—	Not Occupied	—	—
D2	10	RD / GY	142	Battery Positive Voltage	III	—
E1	—	—	—	Not Occupied	—	—
E2	10	RD / GN	242	Battery Positive Voltage	III	—
F1	—	—	—	Not Occupied	—	—
F2	0.35	BN / YE	820	Center High Mounted Stop Lamp Supply Voltage	I	—
F3	0.35	BU / BN	38	Backup Lamp Relay Control	I	—
F4	0.35	BN / WH	28	Horn Relay Control	I	—
F5 - F8	—	—	—	Not Occupied	—	—
G1	0.75	BN / GY	29	Horn Control	II	—
G2	—	—	—	Not Occupied	—	—
G3	1.5	BN / GN	4246	Identification Lamp Control	II	—

**X50A Engine Wiring Harness Junction Block X2 (cont'd)**

<b>Pin</b>	<b>Size</b>	<b>Color</b>	<b>Circuit</b>	<b>Function</b>	<b>Terminal Type ID</b>	<b>Option</b>
G4	—	—	—	Not Occupied	—	—
G5	1.5	RD / BN	1440	Battery Positive Voltage	II	—
G6	1	RD / BN	1140	Battery Positive Voltage	II	—
H1	0.5	BU / BK	1053	Center High Mounted Stop Lamp Control 3	II	—
H2	—	—	—	Not Occupied	—	—
H3	0.5	RD / GN	3140	Battery Positive Voltage	II	—
H4 - H5	—	—	—	Not Occupied	—	—
H6	0.35	WH / BN	7055	Auxiliary Park Lamp Relay Control	II	—

**X50A Engine Wiring Harness Junction Block X3**

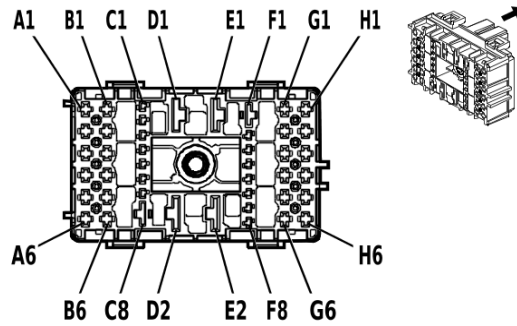

4992608

**Connector Part Information**

Harness Type: Engine Wiring Harness  
 OEM Connector: 33384584  
 Service Connector: 19371176  
 Description: 44-Way F 1.5, 2.8, 6.3 CTS, 9.5 MCON-LL Series( GY)

**Terminal Part Information**

Terminal Type ID	Terminated Lead	Diagnostic Test Probe	Terminal Removal Tool
I	19369711	J-35616-14 (GN)	EL-38125-560A
II	84764078	J-35616-42 (RD)	J-38125-215A
III	84764079	J-35616-44 (YE)	J-38125-11A
IV	84779405	J-35616-35 (VT)	J-38125-215A

**X50A Engine Wiring Harness Junction Block X3**

Pin	Size	Color	Circuit	Function	Terminal Type ID	Option
A1	0.75	VT / GN	439	Run/Crank Ignition 1 Voltage	IV	—
A2 - A3	—	—	—	Not Occupied	—	—
A4	0.75	BN / GN	59	Air Conditioning Compressor Clutch Control	IV	—
A5	1.5	RD / GY	8540	Battery Positive Voltage	IV	—
A6	0.5	GN	8016	Secondary Axle Motor Control	IV	—
B1	2.5	YE	6	Starter Solenoid Crank Ignition Voltage	IV	—
B2	0.5	YE / BK	625	Starter Enable Relay Control	IV	—
B3	0.5	VT / GY	8017	Secondary Axle Motor Relay Control	IV	—
B4 - B5	—	—	—	Not Occupied	—	—
B6	3	GN / RD	6042	Cruise Control Switch 5V Reference	IV	—
C1	0.5	BU	3017	Fuel Heater Relay 1 Control	I	—
C2	—	—	—	Not Occupied	—	—
C3	0.5	BK	450	Ground	I	L3B
	1	BK	450	Ground	I	L84 / L87
	0.75	BK	450	Ground	I	LZ0
C4	0.5	WH / GY	459	Air Conditioning Compressor Clutch Relay Control	I	—
C5	0.5	GN / BU	3889	Powertrain Sensor Bus Relay Control	I	—
C6	1	VT / GN	4320	Powertrain Sensor Bus Enable	I	—
C7 - D1	—	—	—	Not Occupied	—	—

**X50A Engine Wiring Harness Junction Block X3 (cont'd)**

Pin	Size	Color	Circuit	Function	Terminal Type ID	Option
D2	5	RD / GN	3840	Battery Positive Voltage	III	—
E1	5	RD / GY	4140	Battery Positive Voltage	III	—
E2	5	RD / PU	4040	Battery Positive Voltage	III	—
F1	2.5	YE / GN	4358	Starter Pinion Solenoid Voltage	II	—
F2	0.5	YE / VT	4325	Starter Pinion Solenoid Actuator Relay Control	I	—
F3	0.5	RD / BN	440	Battery Positive Voltage	I	L84 / L87 / L3B LZ0
	0.75	RD / BN	440	Battery Positive Voltage	I	
F4	0.5	YE	5991	Powertrain Relay Coil Control	I	—
F5	0.5	RD / BU	6040	Battery Positive Voltage	I	—
F6	—	—	—	Not Occupied	—	—
F7	0.5	VT / BU	5705	Powertrain Main Relay Control	I	—
F8 - G1	—	—	—	Not Occupied	—	—
G2	2	VT / BU	5292	Powertrain Main Relay Fused Supply Voltage 3	IV	—
G3	—	—	—	Not Occupied	—	—
G4	0.75	VT / BU	5293	Powertrain Main Relay Fused Supply Voltage 4	IV	—
G5	1.5	VT / GN	4320	Powertrain Sensor Bus Enable	IV	—
G6	1	VT / BU	5291	Powertrain Main Relay Fused Supply Voltage 2	IV	—
H1	2.5	VT / BU	5290	Powertrain Main Relay Fused Supply Voltage 1	IV	—
H2	0.75	VT / BU	5292	Powertrain Main Relay Fused Supply Voltage 3	IV	—
H3	1	VT / BU	5294	Powertrain Main Relay Fused Supply Voltage 5	IV	—
H4	0.75	VT / BU	5293	Powertrain Main Relay Fused Supply Voltage 4	IV	—
H5	2.5	VT / BU	5291	Powertrain Main Relay Fused Supply Voltage 2	IV	—
H6	—	—	—	Not Occupied	—	—

**X50A Engine Wiring Harness Junction Block X4**

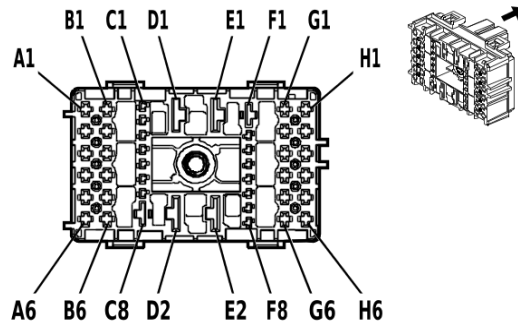

4993031

**Connector Part Information**

Harness Type: Chassis Wiring Harness  
 OEM Connector: 33384574  
 Service Connector: 19371188  
 Description: 44-Way F 1.5, 2.8, 6.3 CTS, 9.5 MCON-LL Series( BK)

**Terminal Part Information**

Terminal Type ID	Terminated Lead	Diagnostic Test Probe	Terminal Removal Tool
I	19369711	J-35616-14 (GN)	EL-38125-560A
II	84764078	J-35616-42 (RD)	J-38125-215A
III	84764079	J-35616-44 (YE)	J-38125-11A
IV	84779405	J-35616-35 (VT)	J-38125-215A

**X50A Engine Wiring Harness Junction Block X4**

Pin	Size	Color	Circuit	Function	Terminal Type ID	Option
A1	—	—	—	Not Occupied	—	—
A2	0.5	RD / BU	5240	Battery Positive Voltage	IV	—
A3	1.5	BN	2109	Trailer Park Lamp Control	IV	—
A4 - A5	—	—	—	Not Occupied	—	—
A6	0.5	VT / WH	639	Run/Crank Ignition 1 Voltage	IV	—
B1	—	—	—	Not Occupied	—	—
B2	1	GY	1624	Trailer Backup Lamp Control	IV	—
B3	0.75	RD / GN	2440	Battery Positive Voltage	IV	—
B4	0.5	RD / GN	6940	Battery Positive Voltage	IV	—
B5 - C6	—	—	—	Not Occupied	—	—
C7	1.5	RD / WH	3440	Battery Positive Voltage	I	FHX
	0.5	RD / WH	3440	Battery Positive Voltage	I	FJW
C8	2.5	BN / YE	2996	Fuel Heater Control 1	II	—
D1	—	—	—	Not Occupied	—	—
D2	4	OG	3640	Battery Positive Voltage	III	—
E1 - E2	—	—	—	Not Occupied	—	—
F1	2.5	RD / WH	2040	Battery Positive Voltage	II	—
F2 - G2	—	—	—	Not Occupied	—	—
G3	1	YE	1618	Left Rear Trailer Stop/Turn Lamp Control	IV	—

**X50A Engine Wiring Harness Junction Block X4 (cont'd)**

<b>Pin</b>	<b>Size</b>	<b>Color</b>	<b>Circuit</b>	<b>Function</b>	<b>Terminal Type ID</b>	<b>Option</b>
G4	2.5	RD / YE	5840	Battery Positive Voltage	IV	—
G5	1.5	RD / WH	5940	Battery Positive Voltage	IV	—
G6	2.5	RD / WH	1040	Battery Positive Voltage	IV	—
H1 - H2	—	—	—	Not Occupied	—	—
H3	1	GN	1619	Right Rear Trailer Stop/Turn Lamp Control	IV	—
H4	2.5	RD / VT	5640	Battery Positive Voltage	IV	—
H5	2.5	RD / VT	1940	Battery Positive Voltage	IV	—
H6	4	OG	3940	Battery Positive Voltage	IV	—

**X50A Engine Wiring Harness Junction Block X5**

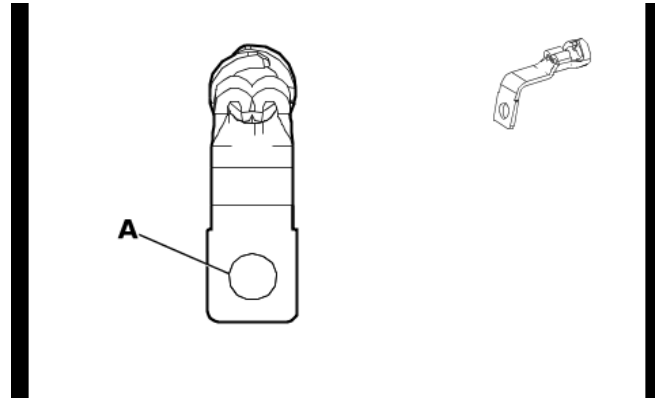

5525767

**Connector Part Information**

Harness Type: Starter Solenoid Cable  
 OEM Connector: 84386513  
 Service Connector: Service by Cable Assembly — See Part Catalog  
 Description: 1-Way Ring Terminal

**Terminal Part Information**

Terminal Type ID	Terminated Lead	Diagnostic Test Probe	Terminal Removal Tool
I	Not required	No Tool Required	No Tool Required

**X50A Engine Wiring Harness Junction Block X5**

Pin	Size	Color	Circuit	Function	Terminal Type ID	Option
A	35	RD / BU	42	Battery Positive Voltage	I	—



X51AX Instrument Panel Wiring Harness Junction Block - Auxiliary Label (9L7)

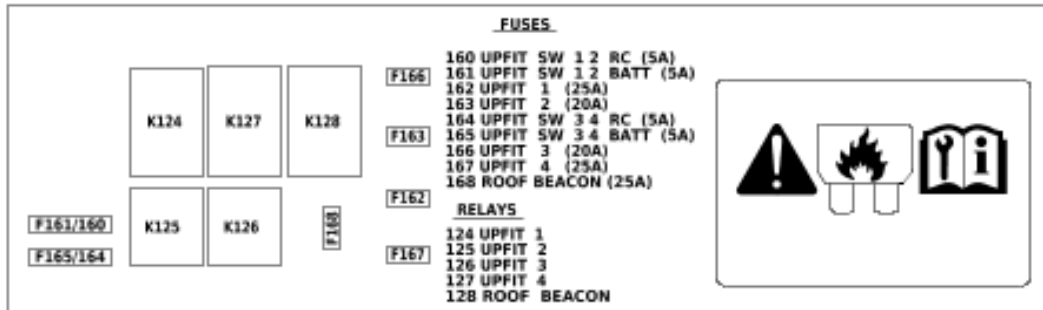

5969422

X51AX Instrument Panel Wiring Harness Junction Block - Auxiliary Top View (9L7)

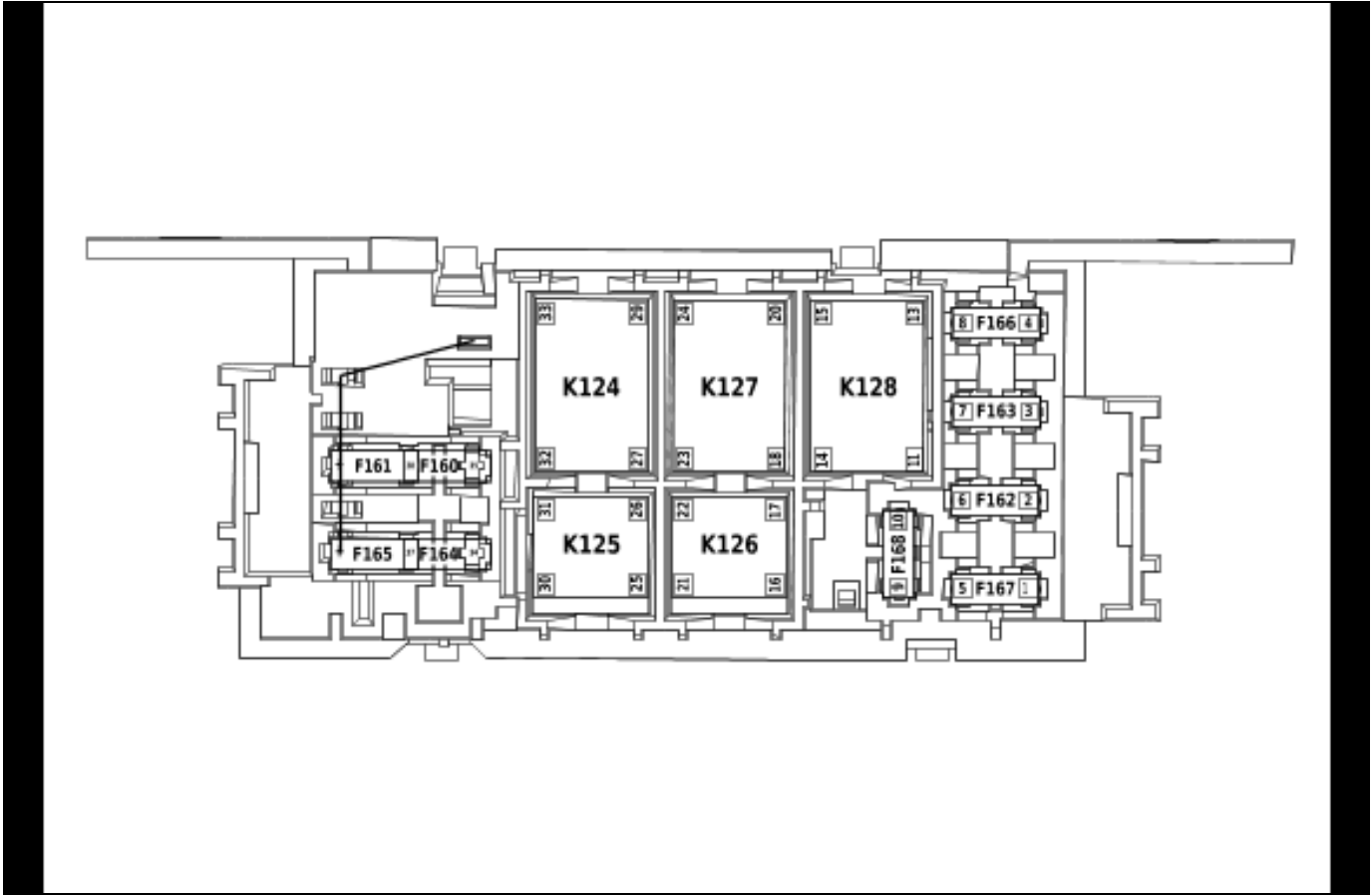

5988611

Usage Table

No.	Device Label Name	Device Assigned Name	Rating	Description
<b>Fuses</b>				
F160	UPFIT SW 1 2 RC	F160DA	5A	<ul style="list-style-type: none"> <li>• KR161AA Configurable/Accessory Provision Relay 1</li> <li>• KR161BA Configurable/Accessory Provision Relay 2</li> </ul>
F161	UPFIT SW 1 2 BATT	F161DA	5A	<ul style="list-style-type: none"> <li>• KR161AA Configurable/Accessory Provision Relay 1</li> <li>• KR161BA Configurable/Accessory Provision Relay 2</li> </ul>
F162	UPFIT 1	F162DA	25A	<ul style="list-style-type: none"> <li>• X79A Configurable/Accessory Provision Supply Connector</li> </ul>
F163	UPFIT 2	F163DA	20A	<ul style="list-style-type: none"> <li>• X79A Configurable/Accessory Provision Supply Connector</li> </ul>
F164	UPFIT SW 3 4 RC	F164DA	5A	<ul style="list-style-type: none"> <li>• KR161CA Configurable/Accessory Provision Relay 3</li> <li>• KR161DA Configurable/Accessory Provision Relay 4</li> <li>• KR161EA Configurable/Accessory Provision Relay 5</li> </ul>
F165	UPFIT SW 3 4 BATT	F165DA	5A	<ul style="list-style-type: none"> <li>• KR161CA Configurable/Accessory Provision Relay 3</li> <li>• KR161DA Configurable/Accessory Provision Relay 4</li> <li>• KR161EA Configurable/Accessory Provision Relay 5</li> </ul>
F166	UPFIT 3	F166DA	20A	<ul style="list-style-type: none"> <li>• X79A Configurable/Accessory Provision Supply Connector</li> </ul>
F167	UPFIT 4	F167DA	25A	<ul style="list-style-type: none"> <li>• X79A Configurable/Accessory Provision Supply Connector</li> </ul>
F168	ROOF BEACON	F168DA	25A	<ul style="list-style-type: none"> <li>• X79A Configurable/Accessory Provision Supply Connector</li> </ul>

**Usage Table (cont'd)**

No.	Device Label Name	Device Assigned Name	Rating	Description
<b>Relays</b>				
K124	UPFIT 1	KR161AA Configurable/Accessory Provision Relay 1	—	• F162DA
K125	UPFIT 2	KR161BA Configurable/Accessory Provision Relay 2	—	• F163DA
K126	UPFIT 3	KR161CA Configurable/Accessory Provision Relay 3	—	• F166DA
K127	UPFIT 4	KR161DA Configurable/Accessory Provision Relay 4	—	• F167DA
K128	ROOF BEACON	KR161EA Configurable/Accessory Provision Relay 5	—	• F168DA

**X51AX Instrument Panel Wiring Harness Junction Block - Auxiliary**

**Connector Part Information**

Harness Type: Auxiliary Fuse Block Wiring Harness  
 OEM Connector: 33323307  
 Service Connector: Service by Component Assembly - See Part Catalog  
 Description: —

**Terminal Part Information**

Terminal Type ID	Terminated Lead	Diagnostic Test Probe	Terminal Removal Tool
I	Not required	J-35616-22 (RD)	No Tool Required
II	Not required	J-35616-35 (VT)	No Tool Required

**X51AX Instrument Panel Wiring Harness Junction Block - Auxiliary**

Pin	Size	Color	Circuit	Function	Terminal Type ID	Option
1	2.5	YE / BN	10734	Upfitter Accessory 4 Supply Voltage	II	—
2	2.5	BU	10731	Upfitter Accessory 1 Supply Voltage	II	—
3	2.5	GY / BK	10732	Upfitter Accessory 2 Supply Voltage	II	—
4	2.5	BN / WH	10733	Upfitter Accessory 3 Supply Voltage	II	—
5	2.5	YE	10729	Upfitter Accessory Fuse 4 Supply Voltage	II	—
6	2.5	BU / GN	10726	Upfitter Accessory Fuse 1 Supply Voltage	II	—
7	2.5	GY	10727	Upfitter Accessory Fuse 2 Supply Voltage	II	—
8	2.5	BN	10728	Upfitter Accessory Fuse 3 Supply Voltage	II	—
9	2.5	VT / BU	10735	Upfitter Accessory 5 Supply Voltage	II	—
10	2.5	VT	10730	Upfitter Accessory Fuse 5 Supply Voltage	II	—
11	2.5	VT	10730	Upfitter Accessory Fuse 5 Supply Voltage	II	—
13	0.35	VT / BN	10723	Upfitter Accessory Relay 3 Coil Supply Voltage	II	—
14	0.35	GY / VT	10720	Upfitter Accessory Relay 5 Coil Control	II	—
15	2.5	RD / VT	542	Battery Positive Voltage	II	—
16	2.5	RD / VT	542	Battery Positive Voltage	II	—
17	0.35	GN / BN	10718	Upfitter Accessory Relay 3 Coil Control	II	—
18	2.5	YE	10729	Upfitter Accessory Fuse 4 Supply Voltage	II	—
20	0.35	VT / BN	10723	Upfitter Accessory Relay 3 Coil Supply Voltage	II	—
21	0.35	VT / BN	10723	Upfitter Accessory Relay 3 Coil Supply Voltage	II	—
22	2.5	BN	10728	Upfitter Accessory Fuse 3 Supply Voltage	II	—
23	0.35	WH / YE	10719	Upfitter Accessory Relay 4 Coil Control	II	—
24	2.5	RD / VT	542	Battery Positive Voltage	II	—
25	2.5	RD / VT	542	Battery Positive Voltage	II	—
26	0.35	VT / GY	10717	Upfitter Accessory Relay 2 Coil Control	II	—
27	2.5	BU / GN	10726	Upfitter Accessory Fuse 1 Supply Voltage	II	—
29	0.35	BU / VT	10721	Upfitter Accessory Relay 1 Coil Supply Voltage	II	—
30	0.35	BU / VT	10721	Upfitter Accessory Relay 1 Coil Supply Voltage	II	—
31	2.5	GY	10727	Upfitter Accessory Fuse 2 Supply Voltage	II	—
32	0.35	BU / WH	10716	Upfitter Accessory Relay 1 Coil Control	II	—
33	2.5	RD / VT	542	Battery Positive Voltage	II	—
34	0.5	VT / BK	339	Run/Crank Ignition 1 Voltage	II	—

**X51AX Instrument Panel Wiring Harness Junction Block - Auxiliary (cont'd)**

Pin	Size	Color	Circuit	Function	Terminal Type ID	Option
35	0.5	VT / BK	339	Run/Crank Ignition 1 Voltage	II	—
36	10	RD / VT	542	Battery Positive Voltage	I	—
37	0.35	VT / BN	10723	Upfitter Accessory Relay 3 Coil Supply Voltage	II	—
38	0.35	BU / VT	10721	Upfitter Accessory Relay 1 Coil Supply Voltage	II	—
39	2.5	RD / VT	542	Battery Positive Voltage	II	—
40	2.5	RD / VT	542	Battery Positive Voltage	II	—
41	2.5	RD / VT	542	Battery Positive Voltage	II	—
42	2.5	RD / VT	542	Battery Positive Voltage	II	—
43	2.5	RD / VT	542	Battery Positive Voltage	II	—

**X53AF Body Wiring Harness Junction Block Label**

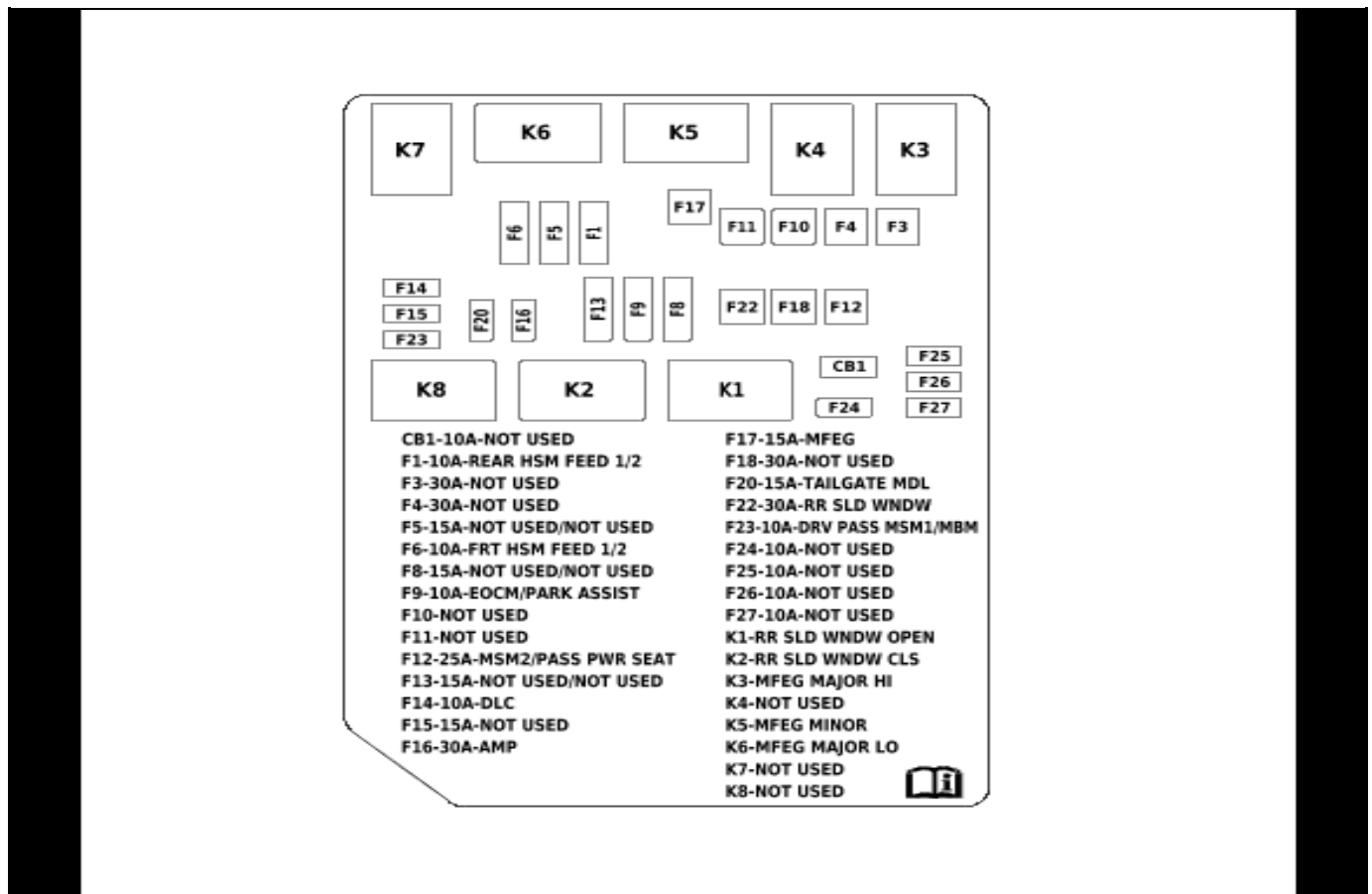

5969417

X53AF Body Wiring Harness Junction Block Top View

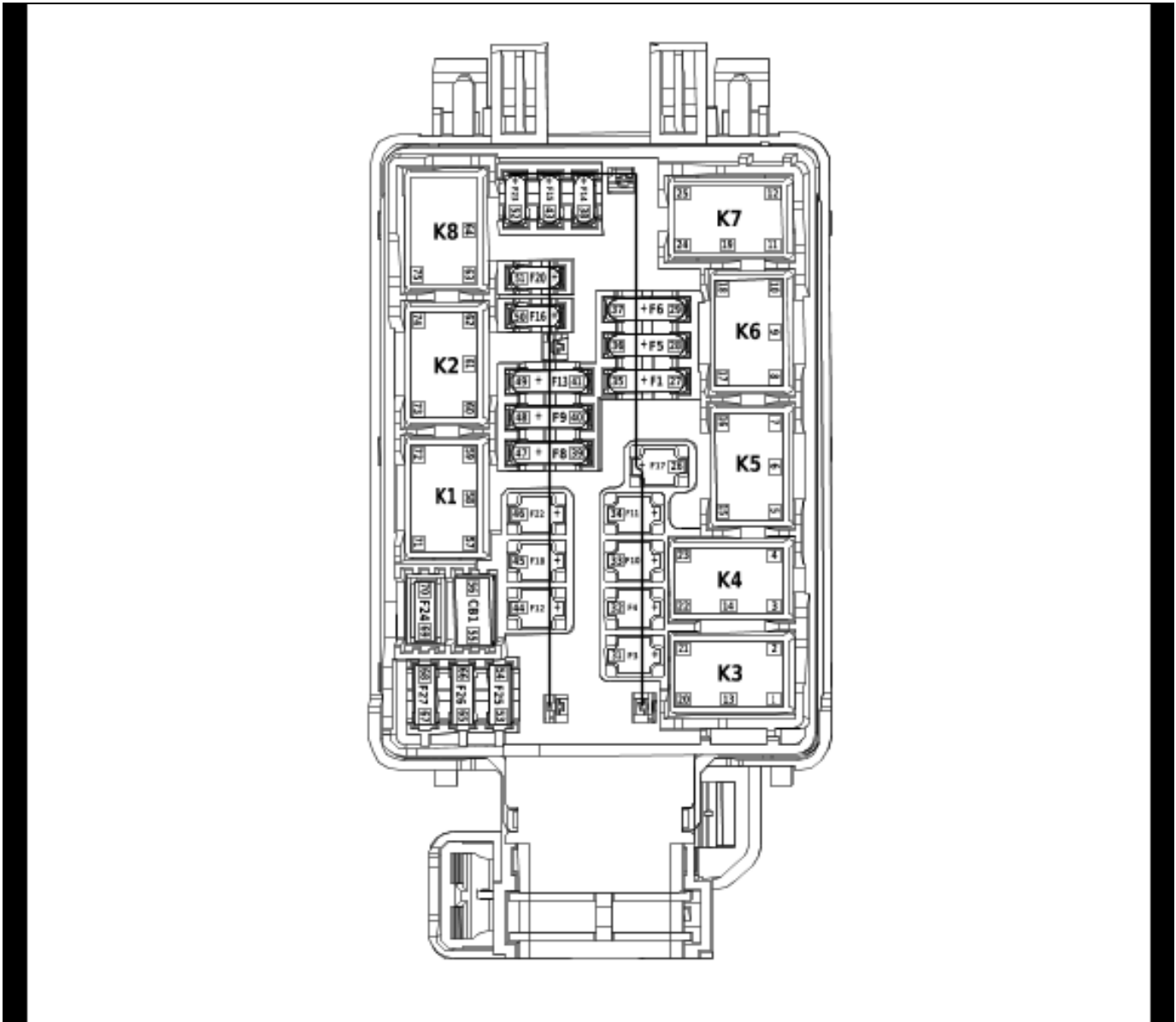

6143341

Usage Table

No.	Device Label Name	Device Assigned Name	Rating	Description
<b>Fuses</b>				
F1	REAR HSM FEED 1/2	F1DL	10A	• K29R Rear Seat Heater Control Module (KA6)
F3	NOT USED	F3DL	30A	• Not Used
F4	NOT USED	F4DL	30A	• Not Used
F5	NOT USED/NOT USED	F5DL	15A	• Not Used
F6	FRT HSM FEED 1/2	F6DL	10A	• K29FV Front Seat Heater Vent Control Module (KA1/KQV)
F8	NOT USED/NOT USED	F8DL	15A	• Not Used
F9	EOCM/PARK ASSIST	F9DL	10A	• K124 Image Processing Module (UGN) • K182 Parking Assist Control Module (UD5/UD7)

**Usage Table (cont'd)**

No.	Device Label Name	Device Assigned Name	Rating	Description
F10	NOT USED	F10DL	30A	• Not Used
F11	NOT USED	F11DL	30A	• Not Used
F12	MSM2/PASS PWR SEAT	F12DL	25A	• S64P Front Seat Adjuster Switch - Passenger (A7K)
F13	NOT USED/NOT USED	F13DL	15A	• Not Used
F14	DLC	F14DL	10A	• X84 Data Link Connector
F15	NOT USED	F15DL	15A	• Not Used
F16	AMP	F16DL	30A	• T3 Audio Amplifier (UQA)
F17	MFEG	F17DL	15A	• KR191G Pickup Box Endgate Latch Relay - Ground (QT5-QK2) • KR192 Pickup Box Auxiliary Endgate Latch Relay (QK2+QT5)
F18	NOT USED	F18DL	30A	• Not Used
F20	TAILGATE MDL	F20DL	15A	• K194 Rear Gate Module (QT6)
F22	RR SLD WNDW	F22DL	30A	• KR206C Rear Sliding Window Close Relay (A48) • KR206O Rear Sliding Window Open Relay (A48)
F23	DRV PASS MSM1/MBM	F23DL	10A	• K40D Driver Seat Adjuster Memory Module (A45/AUN) • S64D Front Seat Adjuster Switch - Driver (A45) • S65P Front Seat Lumbar Switch - Passenger (A7K)
F24	NOT USED	F24DL	10A	• Not Used
F25	NOT USED	F25DL	10A	• Not Used
F26	NOT USED	F26DL	10A	• Not Used
F27	NOT USED	F27DL	10A	• Not Used
<b>Circuit Breakers</b>				
CB1	NOT USED	CB1DL	10A	• Not Used
<b>Relays</b>				
K1	RR SLD WNDW OPEN	KR206O Rear Sliding Window Open Relay	—	• M63 Rear Sliding Window Motor (A48)
K2	RR WNDW CLS	KR206C Rear Sliding Window Close Relay	—	• M63 Rear Sliding Window Motor (A48)
K3	MFEG MAJOR HI	KR191G Pickup Box Endgate Latch Relay - Ground	—	• A99L Pickup Box Endgate Latch - Left (QK2+QT5) • A99R Pickup Box Endgate Latch - Right (QK2+QT5) • M14A Pickup Box Endgate Lock Actuator (QK1+QT5)
K4	NOT USED	—	—	• Not Used
K5	MFEG MINOR	KR192 Pickup Box Auxiliary Endgate Latch Relay	—	• A100L Pickup Box Auxiliary Endgate Latch - Left (QK2+QT5) • A100R Pickup Box Auxiliary Endgate Latch - Right (QK2+QT5)
K6	MFEG MAJOR LO	KR191S Pickup Box Endgate Latch Relay - Supply Voltage	—	• A99L Pickup Box Endgate Latch - Left (QK2+QT5) • A99R Pickup Box Endgate Latch - Right (QK2+QT5) • A100R Pickup Box Auxiliary Endgate Latch - Right (QT6) • A100R Pickup Box Auxiliary Endgate Latch - Right (QT6) • M14A Pickup Box Endgate Lock Actuator (QK1+QT5)
K7	NOT USED	—	—	• Not Used

**6-66 Electrical Component and Inline Harness Connector End Views**

---

**Usage Table (cont'd)**

<b>No.</b>	<b>Device Label Name</b>	<b>Device Assigned Name</b>	<b>Rating</b>	<b>Description</b>
K8	NOT USED	—	—	• Not Used



## X53AF Body Wiring Harness Junction Block

### Connector Part Information

Harness Type: Body Wiring Harness  
 OEM Connector: 35232561  
 Service Connector: Service by Component Assembly - See Part Catalog  
 Description: —

### Terminal Part Information

Terminal Type ID	Terminated Lead	Diagnostic Test Probe	Terminal Removal Tool
I	13575574	J-35616-5 (PU)	J-38125-215A
II	13578850	J-35616-5 (PU)	J-38125-215A
III	19332366	J-35616-35 (VT)	J-38125-212
IV	Not required	J-35616-22 (RD)	No Tool Required

### X53AF Body Wiring Harness Junction Block

Pin	Size	Color	Circuit	Function	Terminal Type ID	Option
1	0.75	WH / GN	7728	Major Endgate High Relay Control	III	—
2	1	GN	1299	Major Endgate Motor Control	III	—
5	1	VT	7725	Minor Endgate Motor Control	III	—
7	0.75	WH / GY	7297	Minor Endgate High Relay Control	III	—
8	1	BK	1550	Ground	III	—
10	0.75	BU / VT	7729	Major Endgate Low Relay Control	III	—
15	0.5	BK	1550	Ground	III	—
16	1	RD / BN	8240	Battery Positive Voltage	III	—
17	0.5	BK	1550	Ground	III	—
18	1	YE / BK	7730	Major Endgate Motor Low Reference	III	—
20	1	RD / BN	8240	Battery Positive Voltage	III	—
21	0.5	BK	1550	Ground	III	—
26	1	RD / BN	8240	Battery Positive Voltage	II	—
27	0.75	RD / WH	5740	Battery Positive Voltage	III	—
29	0.75	RD / BN	6640	Battery Positive Voltage	III	—
30	10	RD / GY	142	Battery Positive Voltage	IV	—
35	0.75	RD / BU	6740	Battery Positive Voltage	III	—
37	0.75	RD / GN	6140	Battery Positive Voltage	III	—
38	0.5	RD / YE	6540	Battery Positive Voltage	III	—
42	10	RD / GN	242	Battery Positive Voltage	IV	—
44	2.5	RD / YE	7440	Battery Positive Voltage	I	—
46	2.5	RD / VT	8640	Battery Positive Voltage	I	—
48	0.5	RD / WH	4740	Battery Positive Voltage	III	—
50	2.5	RD / YE	3740	Battery Positive Voltage	III	—
51	2.5	RD / VT	4442	Primary Fused Battery Positive Voltage	III	—
52	0.5	RD / BN	2240	Battery Positive Voltage	III	—
57	2.5	RD / VT	8640	Battery Positive Voltage	III	—
58	2.5	BK	1550	Ground	III	—
59	0.5	BK	1550	Ground	III	—

**X53AF Body Wiring Harness Junction Block (cont'd)**

Pin	Size	Color	Circuit	Function	Terminal Type ID	Option
60	2.5	RD / VT	8640	Battery Positive Voltage	III	—
61	2.5	BK	1550	Ground	III	—
62	0.5	BK	1550	Ground	III	—
71	0.5	YE / VT	6191	Power Rear Window Switch Open Signal	III	—
72	2	VT / YE	7453	Window Motor Rear Auxiliary Open Control	III	—
73	0.5	WH	6192	Sliding Rear Window Switch Close Signal	III	—
74	2	YE	7454	Window Motor Rear Auxiliary Close Control	III	—

**X51R Instrument Panel Wiring Harness Junction Block - Right Label**

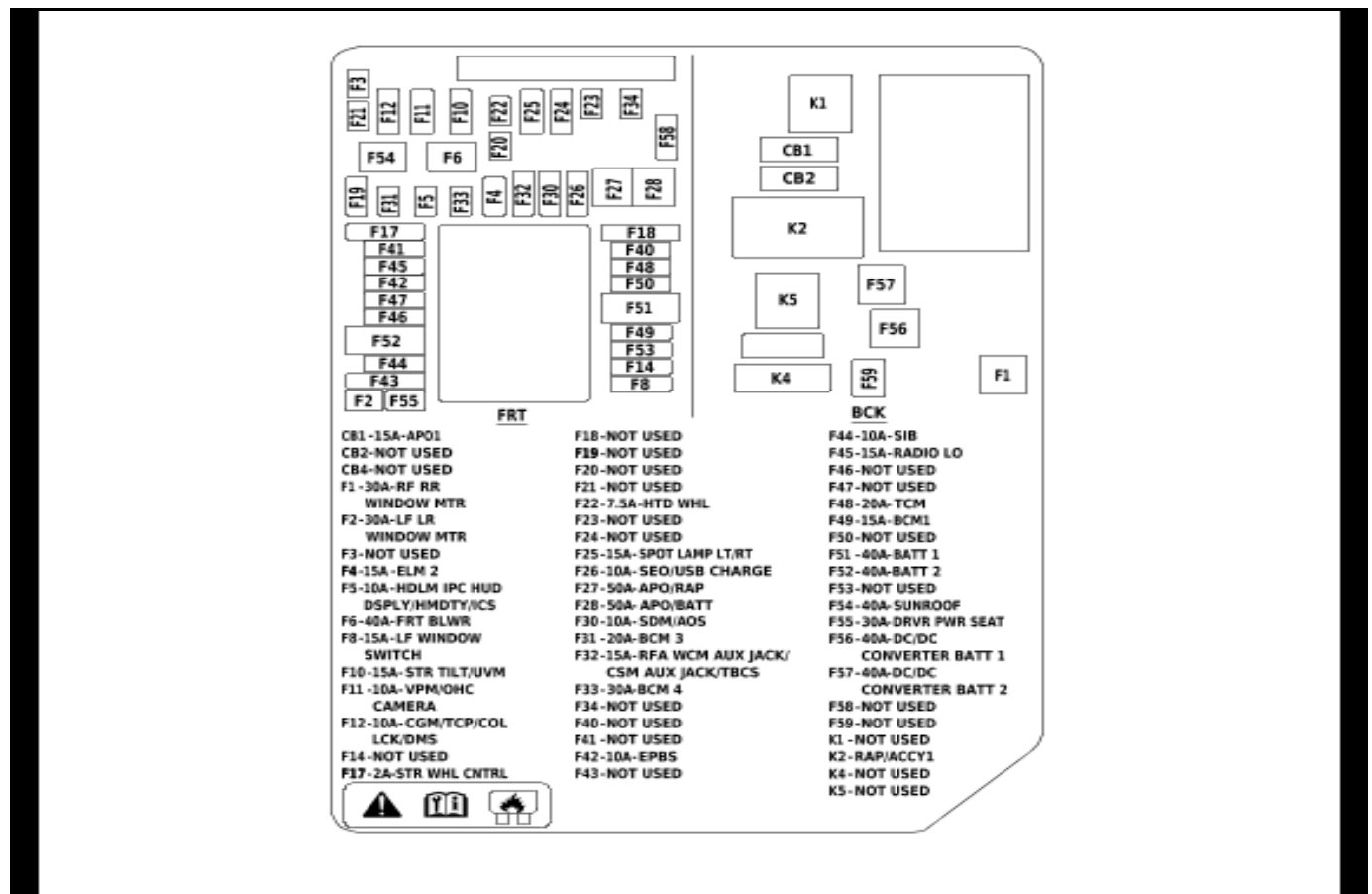

5969420

X51R Instrument Panel Wiring Harness Junction Block - Right Top View

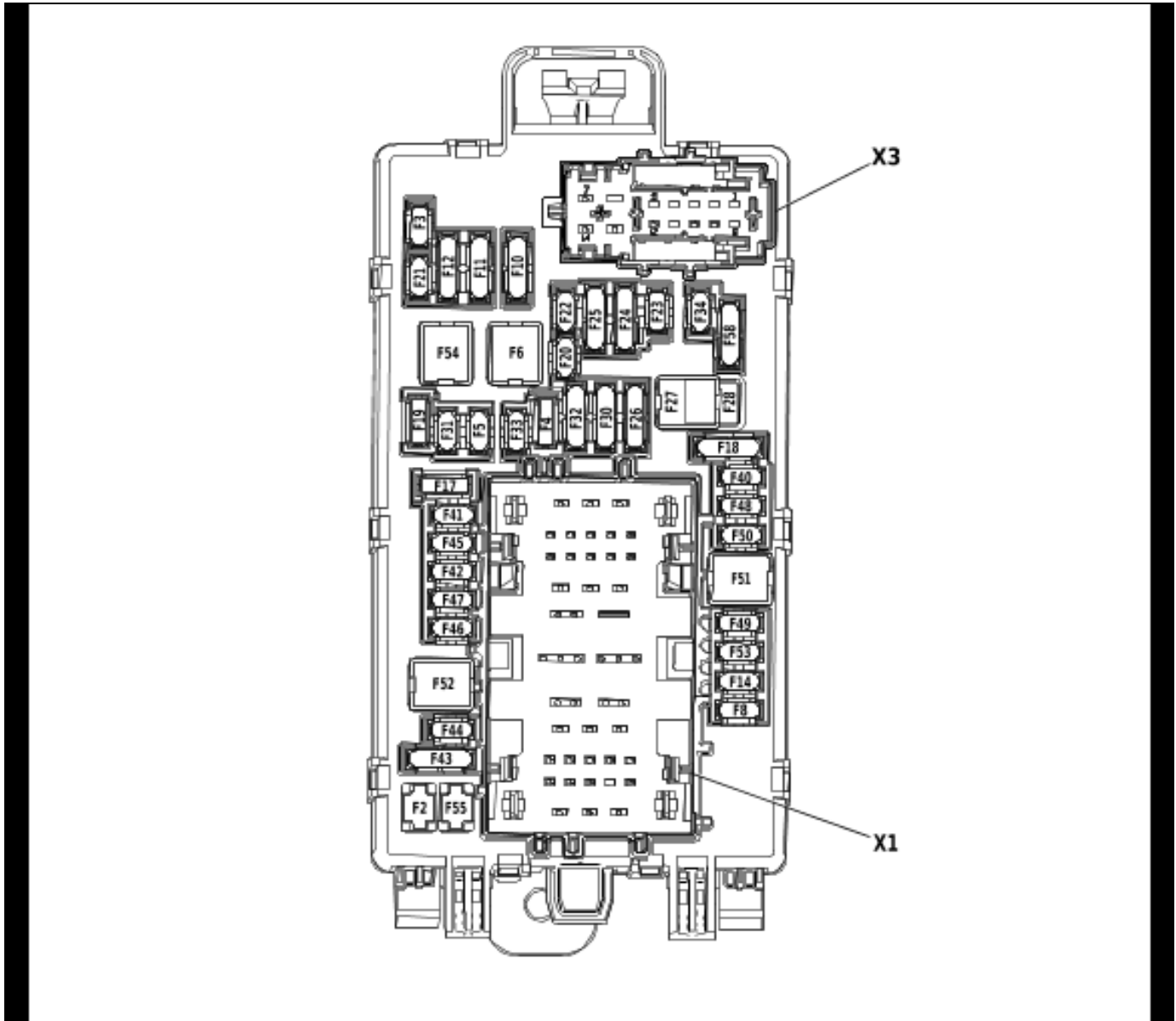

5041376

Usage Table

No.	Device Label Name	Device Assigned Name	Rating	Description
<b>Fuses</b>				
F1	RF RR WINDOW MTR	F1DR	30A	<ul style="list-style-type: none"> <li>M74P Front Side Door Window Regulator Motor - Passenger (AEF)</li> <li>S79P Front Side Door Window Switch - Passenger (AED/AEF)</li> <li>S79RR Rear Side Door Window Switch - Right</li> </ul>
F2	LF LR WINDOW MTR	F2DR	30A	<ul style="list-style-type: none"> <li>M74D Front Side Door Window Regulator Motor - Driver</li> <li>S79LR Rear Side Door Window Switch - Left</li> </ul>
F3	NOT USED	F3DR	—	<ul style="list-style-type: none"> <li>Not Used</li> </ul>
F4	ELM 2	F4DR	15A	<ul style="list-style-type: none"> <li>K219 Lighting Control Module</li> </ul>
F5	HDLM IPC HUD DSPLY/HMDTY/ICS	F5DR	10A	<ul style="list-style-type: none"> <li>K219 Lighting Control Module</li> </ul>

## 6-70 Electrical Component and Inline Harness Connector End Views

### Usage Table (cont'd)

No.	Device Label Name	Device Assigned Name	Rating	Description
F6	FRT BLWR	F6DR	40A	<ul style="list-style-type: none"> <li>M8 Blower Motor</li> </ul>
F8	LF WINDOW SWITCH	F8DR	15A	<ul style="list-style-type: none"> <li>S79D Front Side Door Window Control Switch - Driver</li> <li>S32R Rear Seat Heater Switch (KA6)</li> </ul>
F10	STR TILT/UVM	F10DR	15A	<ul style="list-style-type: none"> <li>K99 Steering Column Tilt Wheel and Telescope Control Module (N38)</li> <li>K219 Lighting Control Module</li> </ul>
F11	VPM/OHC CAMERA	F11DR	10A	<ul style="list-style-type: none"> <li>A103 Roof Console</li> <li>B174W Front View Camera - Windshield (UGN/UHY)</li> <li>K157 Video Processing Module (UV2)</li> </ul>
F12	CGM/TCP/COLLCK/DMS	F12DR	10A	<ul style="list-style-type: none"> <li>K56 Serial Data Gateway Module</li> <li>K60 Column Lock Module</li> <li>K73 Telematic Control Module (UDA/UE1)</li> <li>K180 Driver Monitoring System Module (UKL)</li> </ul>
F14	NOT USED	F14DR	—	<ul style="list-style-type: none"> <li>Not Used</li> </ul>
F17	STR WHL CNTRL	F17DR	2A	<ul style="list-style-type: none"> <li>S70L Cruise Control Switch (KI3)</li> <li>S70R Radio Control Switch - Steering Wheel (KI3)</li> </ul>
F18	NOT USED	F18DR	—	<ul style="list-style-type: none"> <li>Not Used</li> </ul>
F19	NOT USED	F19DR	—	<ul style="list-style-type: none"> <li>Not Used</li> </ul>
F20	NOT USED	F20DR	—	<ul style="list-style-type: none"> <li>Not Used</li> </ul>
F21	NOT USED	F21DR	—	<ul style="list-style-type: none"> <li>Not Used</li> </ul>
F22	HTD WHL	F22DR	7.5A	<ul style="list-style-type: none"> <li>K32 Steering Wheel Heating Control Module (KI3-UKL)</li> <li>K180S Driver Monitoring System Module - Steering Wheel (KI3+UKL)</li> </ul>
F23	NOT USED	F23DR	—	<ul style="list-style-type: none"> <li>Not Used</li> </ul>
F24	NOT USED	F24DR	—	<ul style="list-style-type: none"> <li>Not Used</li> </ul>
F25	SPOT LAMP LT/RT	F25DR	15A	<ul style="list-style-type: none"> <li>X219 (5W4)</li> <li>X220 (5W4)</li> </ul>
F26	SEO/USB CHARGE	F26DR	10A	<ul style="list-style-type: none"> <li>X92CD Dual Charge Only Receptacle - Floor Console Rear (D07+UBI)</li> <li>X92FSR Dual Charge Only Receptacle - Front Center Seat Rear Cover (AZ3+UBI)</li> </ul>
F27	APO/RAP	F27DR	50A	<ul style="list-style-type: none"> <li>Not Used</li> </ul>
F28	APO/BATT	F28DR	50A	<ul style="list-style-type: none"> <li>Not Used</li> </ul>
F30	SDM/AOS	F30DR	10A	<ul style="list-style-type: none"> <li>A22 Radio Control (IOK)</li> <li>A26 Heater and Air Conditioning User Interface Control - Front</li> <li>K36 Restraints Control Module</li> <li>K85P Restraints Occupant Classification System Module - Passenger</li> <li>K179 Automated Driving Mapping Module (UKL)</li> <li>P16 Instrument Panel Cluster Control Module</li> <li>P29 Head-Up Display (UV6)</li> </ul>
F31	BCM 3	F31DR	20A	<ul style="list-style-type: none"> <li>K9 Body Control Module</li> </ul>

**Usage Table (cont'd)**

No.	Device Label Name	Device Assigned Name	Rating	Description
F32	RFA WCM AUX JACK/CSM AUX JACK/TBCS	F32DR	15A	<ul style="list-style-type: none"> <li>• A11 Radio (IOK)</li> <li>• K77 Remote Function Actuator Module</li> <li>• S76 Trailer Brake Control Switch</li> <li>• T22 Wireless Accessory Charging Module (K4C)</li> <li>• X83B Audio/Video Receptacle (D07)</li> <li>• X92IP USB 2 Port Receptacle - Instrument Panel (IOR)</li> </ul>
F33	BCM 4	F33DR	30A	<ul style="list-style-type: none"> <li>• K9 Body Control Module</li> </ul>
F34	NOT USED	F34DR	—	<ul style="list-style-type: none"> <li>• Not Used</li> </ul>
F40	NOT USED	F40DR	—	<ul style="list-style-type: none"> <li>• Not Used</li> </ul>
F41	NOT USED	F41DR	—	<ul style="list-style-type: none"> <li>• Not Used</li> </ul>
F42	EPBS	F42DR	10A	<ul style="list-style-type: none"> <li>• S91 Parking Brake Control Switch</li> </ul>
F43	NOT USED	F43DR	—	<ul style="list-style-type: none"> <li>• Not Used</li> </ul>

X51R Instrument Panel Wiring Harness Junction Block - Right Bottom View

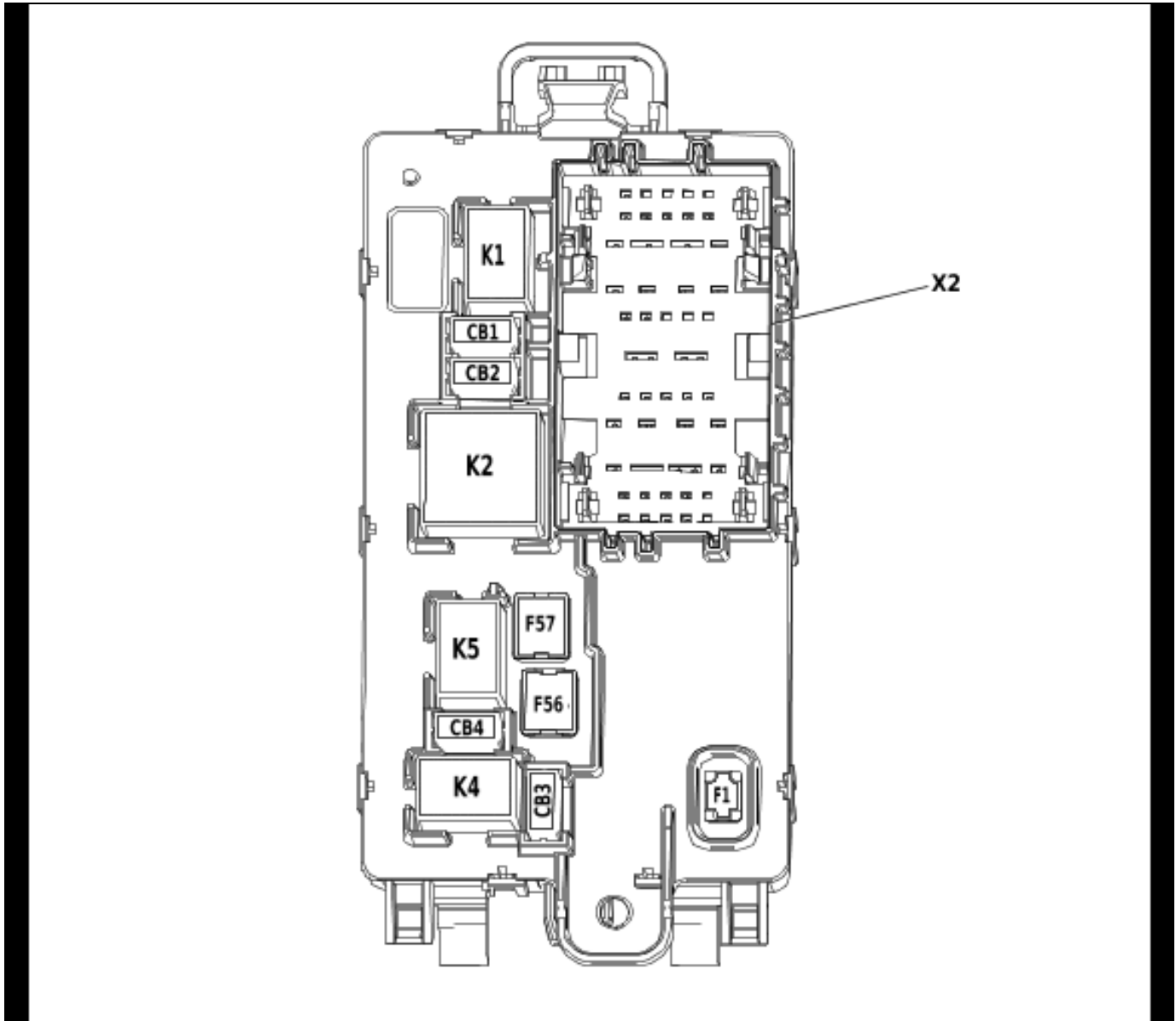

6143342

Usage Table

No.	Device Label Name	Device Assigned Name	Rating	Description
<b>Circuit Breakers</b>				
CB1	APO 1	CB1DR	15A	• X80G Accessory Power Receptacle - Instrument Panel (KC5)
CB2	NOT USED	—	—	• Not Used
<b>Fuses</b>				
F44	SIB	F44DR	10A	• K212 Gear Shift Control Module (MHS/MQC)
F45	RADIO LO	F45DR	15A	• A11 Radio (IOR)
F46	NOT USED	F46DR	—	• Not Used
F47	NOT USED	F47DR	—	• Not Used
F48	TCM	F48DR	20A	• K71 Transmission Control Module
F49	BCM 1	F49DR	15A	• K9 Body Control Module
F50	NOT USED	F50DR	—	• Not Used

**Usage Table (cont'd)**

No.	Device Label Name	Device Assigned Name	Rating	Description
F51	BATT 1	F51DR	40A	• Not Used
F52	BATT 2	F52DR	40A	• Not Used
F53	NOT USED	F53DR	—	• Not Used
F54	SUNROOF	F54DR	40A	• K61 Sunroof Control Module (CF5)
F55	DRVR PWR SEAT	F55DR	30A	• K40D Driver Seat Adjuster Memory Module (A45) • S64D Front Seat Adjuster Switch - Driver (-A45)
F56	DC/DC CONVERTER BATT 1	F56DR	40A	• T19 Multifunction Power Supply Transformer
F57	DC/DC CONVERTER BATT 2	F57DR	40A	• T19 Multifunction Power Supply Transformer
F58	NOT USED	F58DR	—	• Not Used
F59	NOT USED	F59DR	—	• Not Used
<b>Relays</b>				
K1	NOT USED	—	—	• Not Used
K2	RAP/ACCY 1	KR76 Accessory Time Delay Cutoff Relay	—	• CB1DR • F26DR
K4	NOT USED	—	—	• Not Used
K5	NOT USED	—	—	• Not Used

**X51R Instrument Panel Wiring Harness Junction Block - Right X1**

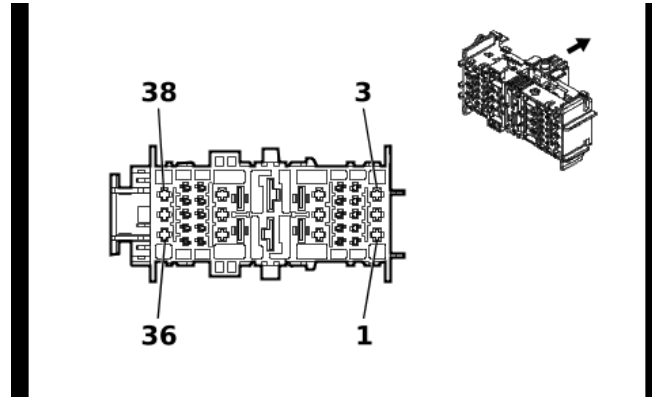

5402140

**Connector Part Information**

Harness Type: Body Wiring Harness  
 OEM Connector: 35264615  
 Service Connector: 84941450  
 Description: 38-Way F 1.5, 2.8, 6.3 MCP, 9.5 MCON-LL Series( BU)

**Terminal Part Information**

Terminal Type ID	Terminated Lead	Diagnostic Test Probe	Terminal Removal Tool
I	19332366	J-35616-35 (VT)	J-38125-212
II	19371175	J-35616-2A (GY)	EL-38125-560A
III	84764078	J-35616-42 (RD)	J-38125-215A
IV	84764079	J-35616-44 (YE)	J-38125-11A
V	Not required	J-35616-22 (RD)	No Tool Required

**X51R Instrument Panel Wiring Harness Junction Block - Right X1**

Pin	Size	Color	Circuit	Function	Terminal Type ID	Option
1 - 2	—	—	—	Not Occupied	—	—
3	1.5	RD / GN	1840	Battery Positive Voltage	I	—
4	0.75	RD / VT	2640	Battery Positive Voltage	II	—
5	0.5	RD / GN	4440	Battery Positive Voltage	II	—
6	0.35	VT	4701	Retained Accessory Power Control	II	—
7 - 13	—	—	—	Not Occupied	—	—
14	0.5	RD / VT	1640	Battery Positive Voltage	I	—
15 - 16	—	—	—	Not Occupied	—	—
17	2.5	RD / GN	2173	12V Regulated Supply Voltage 2	III	—
18	2.5	RD / YE	8140	Battery Positive Voltage	III	—
19	5	RD / YE	1442	Battery Positive Voltage	IV	—
20	10	RD / WH	342	Battery Positive Voltage	V	—
21	2.5	RD / YE	2172	12V Regulated Supply Voltage 1	III	—
22	2.5	RD / WH	8040	Battery Positive Voltage	III	—
23	2.5	RD / GY	4840	Battery Positive Voltage	I	—
24	2.5	RD / BN	4240	Battery Positive Voltage	I	—
25	2.5	RD / BU	3240	Battery Positive Voltage	I	—
26	—	—	—	Not Occupied	—	—



**X51R Instrument Panel Wiring Harness Junction Block - Right X1 (cont'd)**

Pin	Size	Color	Circuit	Function	Terminal Type ID	Option
27	0.5	RD / WH	5440	Battery Positive Voltage	II	—
28 - 29	—	—	—	Not Occupied	—	—
30	0.5	RD / BU	1240	Battery Positive Voltage	II	—
31 - 35	—	—	—	Not Occupied	—	—
36	2.5	RD / YE	5040	Battery Positive Voltage	I	—
37	2.5	RD / GY	3540	Battery Positive Voltage	I	—
38	—	—	—	Not Occupied	—	—

**X51R Instrument Panel Wiring Harness Junction Block - Right X2**

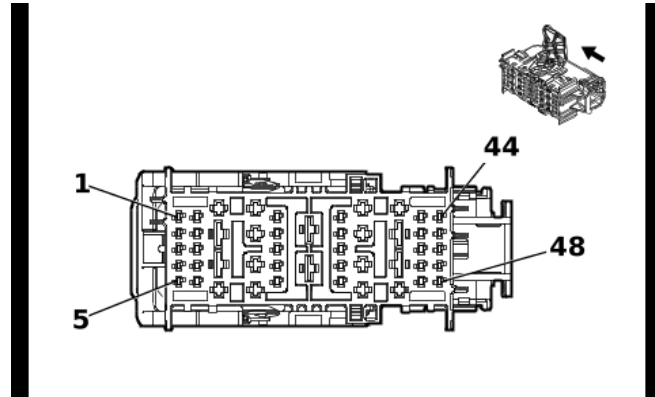

5403539

**Connector Part Information**

Harness Type: Instrument Panel Wiring Harness  
 OEM Connector: 35264616  
 Service Connector: 19371180  
 Description: 48-Way F 1.5, 2.8, 6.3 CTS Series( GN)

**Terminal Part Information**

Terminal Type ID	Terminated Lead	Diagnostic Test Probe	Terminal Removal Tool
I	19369711	J-35616-14 (GN)	EL-38125-560A
II	84764078	J-35616-42 (RD)	J-38125-215A
III	84779405	J-35616-35 (VT)	J-38125-215A

**X51R Instrument Panel Wiring Harness Junction Block - Right X2**

Pin	Size	Color	Circuit	Function	Terminal Type ID	Option
1	0.75	BK	1050	Ground	I	—
2	—	—	—	Not Occupied	—	—
3	0.35	GY / GN	4083	Retained Accessory Power Relay 2 Coil Control	I	—
4 - 7	—	—	—	Not Occupied	—	—
8	0.5	RD / GN	7740	Battery Positive Voltage	I	—
9	0.5	RD / YE	240	Battery Positive Voltage	I	—
10	—	—	—	Not Occupied	—	—
11	0.75	RD / GN	10240	Battery Positive Voltage Police	III	—
12 - 13	—	—	—	Not Occupied	—	—
14	0.35	RD / YE	3040	Battery Positive Voltage	III	—
	0.5	RD / YE	3040	Battery Positive Voltage		
15	0.5	RD / BN	10040	Battery Positive Voltage	III	—
16	0.75	RD / VT	4640	Battery Positive Voltage	III	—
17	—	—	—	Not Occupied	—	—
18	0.35	RD / BN	4940	Battery Positive Voltage	III	—
19	—	—	—	Not Occupied	—	—
20	0.75	RD / GY	10340	Battery Positive Voltage Police	I	—
21 - 23	—	—	—	Not Occupied	—	—
24	4	RD / GY	1740	Battery Positive Voltage	II	—
25	2.5	RD / BU	4540	Battery Positive Voltage	II	—

**X51R Instrument Panel Wiring Harness Junction Block - Right X2 (cont'd)**

Pin	Size	Color	Circuit	Function	Terminal Type ID	Option
26	—	—	—	Not Occupied	—	—
27	0.5	RD / YE	2340	Battery Positive Voltage	I	—
28	0.5	RD / WH	1340	Battery Positive Voltage	I	—
29 - 30	—	—	—	Not Occupied	—	—
31	1.5	VT	1001	Retained Accessory Power Ignition Voltage	III	—
32	2	RD / BU	2540	Battery Positive Voltage	III	—
33	0.5	RD / VT	7140	Battery Positive Voltage	III	—
34	1	RD / GY	2140	Battery Positive Voltage	III	—
35	0.5	RD / GN	1540	Battery Positive Voltage	III	—
36	—	—	—	Not Occupied	—	—
37	1	RD / GY	2840	Battery Positive Voltage	II	—
38 - 40	—	—	—	Not Occupied	—	—
41	0.5	RD / GN	5140	Battery Positive Voltage	I	—
42	0.35	RD / YE	4340	Battery Positive Voltage	I	—
43 - 44	—	—	—	Not Occupied	—	—
45	0.5	RD / WH	2740	Battery Positive Voltage	I	—
46 - 48	—	—	—	Not Occupied	—	—

**X54 Accessory Wiring Junction Block - Snow Plow**

**Connector Part Information**

Harness Type: Accessory Wiring Harness

OEM Connector: 35028846

Service Connector: Service by Component Assembly - See Part Catalog

Description: —

**Terminal Part Information**

Terminal Type ID	Terminated Lead	Diagnostic Test Probe	Terminal Removal Tool
I	Not required	J-35616-35 (VT)	No Tool Required

**X54 Accessory Wiring Junction Block - Snow Plow**

Pin	Size	Color	Circuit	Function	Terminal Type ID	Option
A4	0.5	BN	25	Charge Indicator Control	I	—
A6	0.75	RD	9026	Not Used	I	—
B4	0.75	WH / BU	9030	Not Used	I	—
B5	0.5	BN	9025	Not Used	I	—

## X55SP Wiring Harness Fuse Holder - Snow Plow

### Connector Part Information

Harness Type: Accessory Wiring Harness  
 OEM Connector: 33391084  
 Service Connector: Service by Harness - See Part Catalog  
 Description: —

### Terminal Part Information

Terminal Type ID	Terminated Lead	Diagnostic Test Probe	Terminal Removal Tool
I	Not required	No Tool Required	No Tool Required

### X55SP Wiring Harness Fuse Holder - Snow Plow

Pin	Size	Color	Circuit	Function	Terminal Type ID	Option
A	1	OG	9026	Snow Plow Voltage	I	—
B	1	OG	9028	Snow Plow Voltage	I	—

**Component Connector End Views**

**A3L Sunshade - Left**

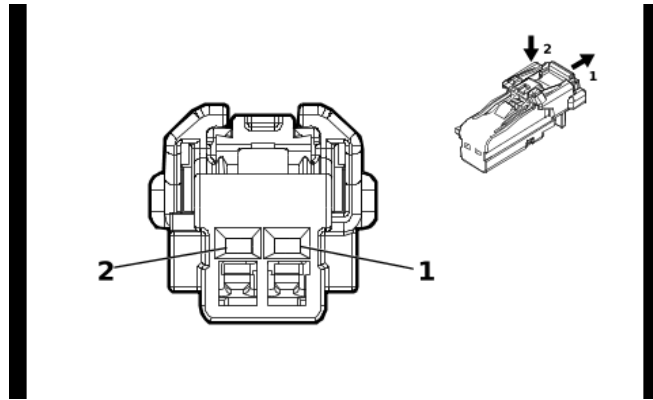

5377746

**Connector Part Information**

Harness Type: Dome Lamp Wiring Harness  
 OEM Connector: 6098-8990  
 Service Connector: 84867147  
 Description: 2-Way F 1.2 MCON Series( BN)

**Terminal Part Information**

Terminal Type ID	Terminated Lead	Diagnostic Test Probe	Terminal Removal Tool
I	Not required	J-35616-12 (BU)	No Tool Required
II	Not required	J-35616-16 (L-GN)	No Tool Required

**A3L Sunshade - Left**

Pin	Size	Color	Circuit	Function	Terminal Type ID	Option
1	0.35	BU / GN	4785	Interior Lamp Overhead Enable Signal	I	—
2	0.5	BK	1050	Ground	II	—

### A3R Sunshade - Right

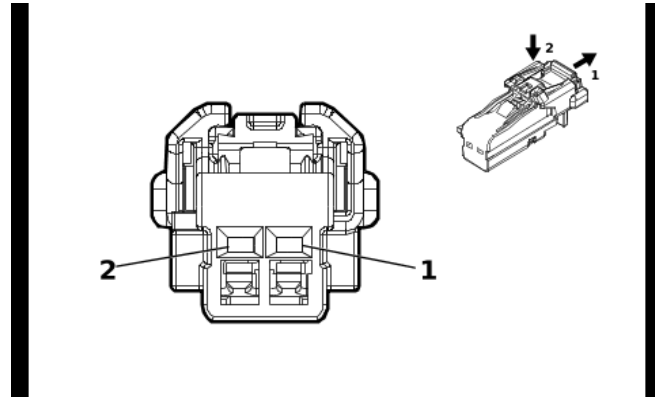

5377746

#### Connector Part Information

Harness Type: Dome Lamp Wiring Harness  
 OEM Connector: 6098-8990  
 Service Connector: 84867147  
 Description: 2-Way F 1.2 MCON Series( BN)

#### Terminal Part Information

Terminal Type ID	Terminated Lead	Diagnostic Test Probe	Terminal Removal Tool
I	Not required	J-35616-12 (BU)	No Tool Required
II	Not required	J-35616-16 (L-GN)	No Tool Required

#### A3R Sunshade - Right

Pin	Size	Color	Circuit	Function	Terminal Type ID	Option
1	0.35	GY / WH	2369	Interior Lamp Overhead 2 Enable Signal	I	—
2	0.5	BK	1050	Ground	II	—

**A7 Fuel Tank Fuel Pump Module**

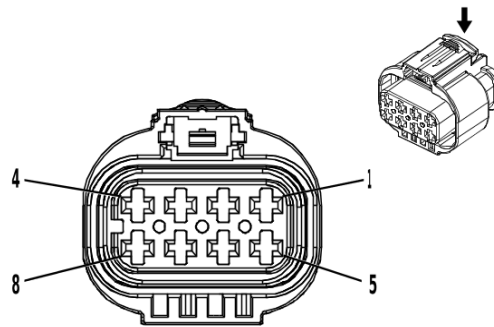

3749582

**Connector Part Information**

Harness Type: Chassis Wiring Harness  
 OEM Connector: 2-2109441-5  
 Service Connector: 19354078  
 Description: 8-Way F 2.8 Series, Sealed( L-GY)

**Terminal Part Information**

Terminal Type ID	Terminated Lead	Diagnostic Test Probe	Terminal Removal Tool
I	Not required	J-35616-35 (VT)	No Tool Required
II	Not required	J-35616-4A (PU)	No Tool Required

**A7 Fuel Tank Fuel Pump Module**

Pin	Size	Color	Circuit	Function	Terminal Type ID	Option
1	2.5	GY	120	Fuel Pump Control	I	—
2	2.5	YE / GY	4137	Fuel Pump Supply Voltage Phase 2	I	—
3	2.5	WH / BN	4138	Fuel Pump Supply Voltage Phase 3	I	—
4	0.5	WH	7444	Fuel Pump Assembly Shield Ground	II	—
5	0.5	BU / GN	1936	Primary Fuel Level Sensor Signal	II	—
6	0.5	BK / GN	6281	Fuel Level Sensor Low Reference	II	—
7 - 8	—	—	—	Not Occupied	—	—



**A9A Outside Rearview Mirror - Driver**

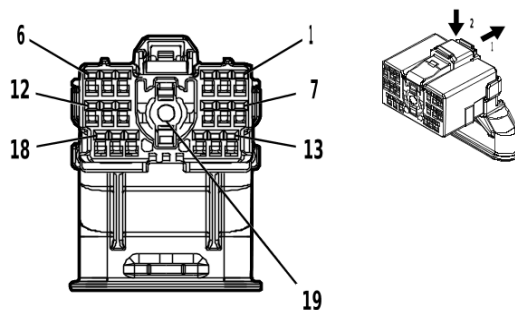

4991775

**Connector Part Information**

Harness Type: Front Side Door Door Wiring Harness - Driver  
 OEM Connector: 6098-8388  
 Service Connector: Service by Harness - See Part Catalog  
 Description: 19-Way F 1.2 MCON, Coaxial Series( BK)

**Terminal Part Information**

Terminal Type ID	Terminated Lead	Diagnostic Test Probe	Terminal Removal Tool
I	Not required	J-35616-16 (L-GN)	No Tool Required
II	Not required	No Tool Required	No Tool Required

**A9A Outside Rearview Mirror - Driver**

Pin	Size	Color	Circuit	Function	Terminal Type ID	Option
1	0.5	BN / BK	2790	Left Front Mirror Motor Right [+] Left [-] Control	I	—
2	0.5	VT / BU	2788	Left Front Mirror Motor Up [+] Down [-] Control	I	—
3	0.5	WH / GN	2786	Left Front Mirror Motor Fold In Control	I	—
4	0.5	GY / YE	1760	Left Side Object Detection LED Control	I	—
5	0.5	WH / GN	5966	Approach Lamp Control	I	DEZ
	0.5	YE / GY	2933	Task Lamp Control Left	I	DQS
6	0.5	WH / YE	2792	Left Front Mirror Position Sensor Left [-] Right [+] Signal	I	—
7	0.5	WH	606	Left Outside Rearview Mirror Heater Control	I	—
8	0.5	WH / GY	2114	Left Turn Signal Lamp Control 2	I	—
9	0.5	BK	1550	Ground	I	—
10	0.5	VT / RD	2791	Left Front Mirror Position Sensor High Reference	I	—
11	0.5	GY / BN	2787	Left Front Mirror Position Sensor Up [+] Down [-] Signal	I	—
12	0.5	BK / YE	1691	Automatic Day/Night Mirror Low Reference	I	—
13	0.5	YE / GY	2933	Task Lamp Control Left	I	DLF/ DEZ
	0.5	BN / GN	4246	Identification Lamp Control	I	DPO/ DQS
14	0.5	YE / BN	2789	Left Front Mirror Motor Common Control	I	—
15	0.5	GY / WH	2785	Left Front Mirror Motor Fold Out Control	I	—
16	0.5	BU / YE	7761	Backup Illumination Lamp Control	I	—
17	0.5	YE / WH	1690	Mirror Dimming Signal	I	—

**6-84 Electrical Component and Inline Harness Connector End Views****A9A Outside Rearview Mirror - Driver (cont'd)**

Pin	Size	Color	Circuit	Function	Terminal Type ID	Option
18	0.5	BK / BN	673	Left Outside Rearview Mirror Position Sensor Low Reference	I	—
19	0	—	4725	Left Sideview Camera LVDS (Low Voltage Differential Signaling) Coaxial Signal	II	—

**A9B Outside Rearview Mirror - Passenger - Double Cab / Crew Cab**

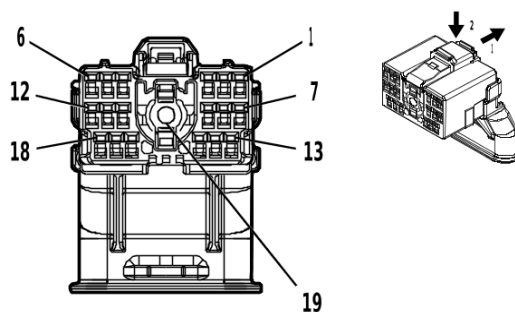

4991775

**Connector Part Information**

Harness Type: Front Side Door Door Wiring Harness - Passenger  
 OEM Connector: 35077331  
 Service Connector: Service by Harness - See Part Catalog  
 Description: 19-Way F 1.2 MCON, Coaxial Series( BK)

**Terminal Part Information**

Terminal Type ID	Terminated Lead	Diagnostic Test Probe	Terminal Removal Tool
I	Not required	J-35616-16 (L-GN)	No Tool Required
II	Not required	No Tool Required	No Tool Required

**A9B Outside Rearview Mirror - Passenger - Double Cab / Crew Cab**

Pin	Size	Color	Circuit	Function	Terminal Type ID	Option
1	0.5	GN / BK	2798	Right Front Mirror Motor Right [+] Left [-] Control	I	—
2	0.5	YE / VT	2796	Right Front Mirror Motor Up [+] Down [-] Control	I	—
3	0.5	BU / GY	2794	Right Front Mirror Motor Fold In Control	I	—
4	0.5	GY	1761	Right Side Object Detection LED Control	I	—
5	0.5	WH / GN	5966	Approach Lamp Control	I	DEZ
	0.5	YE / WH	2934	Task Lamp Control Right	I	DQS
6	0.5	VT / WH	2800	Right Front Mirror Position Sensor Left [-] Right [+] Signal	I	—
7	0.5	BN / VT	607	Right Outside Rearview Mirror Heater Control	I	—
8	0.5	GN / GY	2115	Right Turn Signal Lamp Control 2	I	—
9	0.5	BK	1350	Ground	I	—
10	0.5	YE / RD	2799	Right Front Mirror Position Sensor High Reference	I	—
11	0.5	BU / YE	2795	Right Front Mirror Position Sensor Up [+] Down [-] Signal	I	—
12	0.5	BK / GY	626	Engine Control Vehicle Sensors Low Reference 1	I	—
13	0.5	YE / WH	2934	Task Lamp Control Right	I	DEZ
	0.5	BN / GN	4246	Identification Lamp Control	I	DQS
14	0.5	WH	2797	Right Front Mirror Motor Common Control	I	—
15	0.5	YE / WH	2793	Right Front Mirror Motor Fold Out Control	I	—
16	0.5	BU / YE	7761	Backup Illumination Lamp Control	I	—
17	0.5	BU / GY	636	Ambient Air Temperature Sensor Signal	I	—

**6-86 Electrical Component and Inline Harness Connector End Views****A9B Outside Rearview Mirror - Passenger - Double Cab / Crew Cab (cont'd)**

Pin	Size	Color	Circuit	Function	Terminal Type ID	Option
18	0.5	BK / GN	675	Right Outside Rearview Mirror Position Sensor Low Reference	I	—
19	0	—	4724	Right Sideview Camera LVDS (Low Voltage Differential Signaling) Coaxial Signal	II	—

**A9B Outside Rearview Mirror - Passenger - Regular Cab**

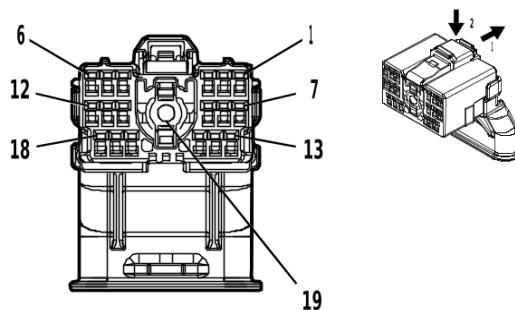

4991775

**Connector Part Information**

Harness Type: Front Side Door Door Wiring Harness - Passenger  
 OEM Connector: 6098-8388  
 Service Connector: Service by Harness - See Part Catalog  
 Description: 19-Way F 1.2 MCON, Coaxial Series( BK)

**Terminal Part Information**

Terminal Type ID	Terminated Lead	Diagnostic Test Probe	Terminal Removal Tool
I	Not required	J-35616-16 (L-GN)	No Tool Required

**A9B Outside Rearview Mirror - Passenger - Regular Cab**

Pin	Size	Color	Circuit	Function	Terminal Type ID	Option
1	0.5	GN / BK	2798	Right Front Mirror Motor Right [+] Left [-] Control	I	—
2	0.5	YE / VT	2796	Right Front Mirror Motor Up [+] Down [-] Control	I	—
3	0.5	BU / GY	2794	Right Front Mirror Motor Fold In Control	I	—
4	0.5	GY	1761	Right Side Object Detection LED Control	I	—
5	0.5	WH / GN	5966	Approach Lamp Control	I	—
6	0.5	VT / WH	2800	Right Front Mirror Position Sensor Left [-] Right [+] Signal	I	—
7	0.5	BN / VT	607	Right Outside Rearview Mirror Heater Control	I	—
8	0.5	GN / GY	2115	Right Turn Signal Lamp Control 2	I	—
9	0.5	BK	1350	Ground	I	—
10	0.5	YE / RD	2799	Right Front Mirror Position Sensor High Reference	I	—
11	0.5	BU / YE	2795	Right Front Mirror Position Sensor Up [+] Down [-] Signal	I	—
12	0.5	BK / GY	626	Engine Control Vehicle Sensors Low Reference 1	I	—
13	0.5	YE / WH	2934	Task Lamp Control Right	I	DEZ
	0.5	BN / GN	4246	Identification Lamp Control	I	DQS
14	0.5	WH	2797	Right Front Mirror Motor Common Control	I	—
15	0.5	YE / WH	2793	Right Front Mirror Motor Fold Out Control	I	—
16	0.5	BU / YE	7761	Backup Illumination Lamp Control	I	—
17	0.5	BU / GY	636	Ambient Air Temperature Sensor Signal	I	—
18	0.5	BK / GN	675	Right Outside Rearview Mirror Position Sensor Low Reference	I	—

**6-88 Electrical Component and Inline Harness Connector End Views****A9B Outside Rearview Mirror - Passenger - Regular Cab (cont'd)**

Pin	Size	Color	Circuit	Function	Terminal Type ID	Option
19	—	—	—	Not Occupied	—	—

**A10 Inside Rearview Mirror X1 (DD8 / DRZ)**

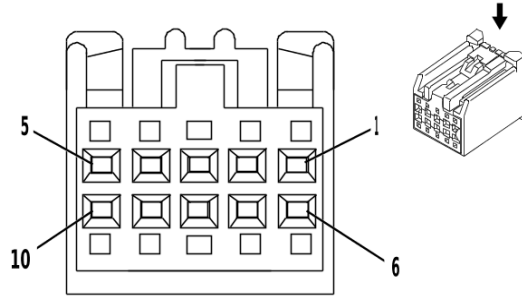

2180211

**Connector Part Information**

Harness Type: Dome Lamp Wiring Harness  
 OEM Connector: AIT2PB-10P-2AK  
 Service Connector: 13577390  
 Description: 10-Way F 0.64 Kaizen Series( BK)

**Terminal Part Information**

Terminal Type ID	Terminated Lead	Diagnostic Test Probe	Terminal Removal Tool
I	13575742	J-35616-64B (L-BU)	J-38125-215A

**A10 Inside Rearview Mirror X1 (DD8 / DRZ)**

Pin	Size	Color	Circuit	Function	Terminal Type ID	Option
1	0.5	GN / WH	24	Backup Lamp Control	I	—
2	0.5	VT / BK	339	Run/Crank Ignition 1 Voltage	I	—
3 - 4	—	—	—	Not Occupied	—	—
5	0.5	BK / WH	851	Signal Ground	I	—
6 - 7	—	—	—	Not Occupied	—	—
8	0.35	BK / YE	1691	Automatic Day/Night Mirror Low Reference	I	—
9	0.35	YE / WH	1690	Mirror Dimming Signal	I	—
10	—	—	—	Not Occupied	—	—

**A10 Inside Rearview Mirror X2 (DRZ)**

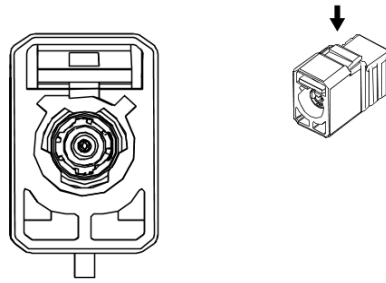

2893647

**Connector Part Information**

Harness Type: Radio Antenna Cable Extension Cable COAX  
 OEM Connector: 13581683  
 Service Connector: Service by Cable Assembly — See Part Catalog  
 Description: 1-Way F Coax Type( BK)

**Terminal Part Information**

Terminal Type ID	Terminated Lead	Diagnostic Test Probe	Terminal Removal Tool
I	Not required	No Tool Required	No Tool Required

**A10 Inside Rearview Mirror X2 (DRZ)**

Pin	Size	Color	Circuit	Function	Terminal Type ID	Option
—	—	Coax Cable	—	Full Display Mirror Rear Camera Coaxial Video Signal	I	—



### A11 Radio X1 (IOK)

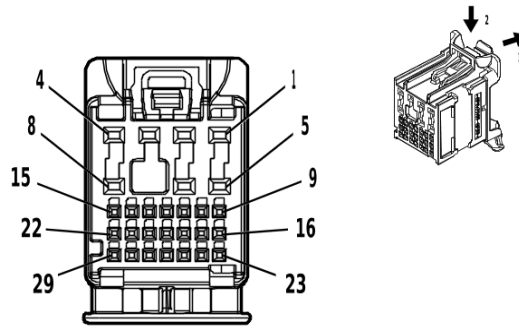

4496253

#### Connector Part Information

Harness Type: Instrument Panel Wiring Harness  
 OEM Connector: 160014-0014  
 Service Connector: 13534974  
 Description: 29-Way F 0.5 NANO, 1.2 MCON, stAK50h Series( BK)

#### Terminal Part Information

Terminal Type ID	Terminated Lead	Diagnostic Test Probe	Terminal Removal Tool
I	19370262	EL-35616-58 (BK)	EL-38125-58
II	84729890	J-35616-12 (BU)	J-38125-215A

#### A11 Radio X1 (IOK)

Pin	Size	Color	Circuit	Function	Terminal Type ID	Option
1	0.5	RD / YE	2340	Battery Positive Voltage	II	—
2	—	—	—	Not Occupied	—	—
3	0.75	BK / WH	1051	Signal Ground	II	—
4 - 7	—	—	—	Not Occupied	—	—
8	0.75	GN / BK	116	Left Rear Speaker [-] Control	II	—
9	0.35	BU	655	Cellular Telephone Microphone Signal	I	UE0
	0.35	GY / YE	5149	Voice Recognition Audio Signal	I	UE1/ UDA
10	0.35	BK / BN	654	Cellular Telephone Microphone Low Reference	I	UE0
	0.35	BK / GY	5152	Voice Recognition Audio [-] Control	I	UE1/ UDA
11	0.35	VT / YE	7043	Microphone [+] Signal	I	—
12	0.35	BU / BK	7044	Microphone [-] Signal	I	—
13 - 29	—	—	—	Not Occupied	—	—

A11 Radio X1 (IOR)

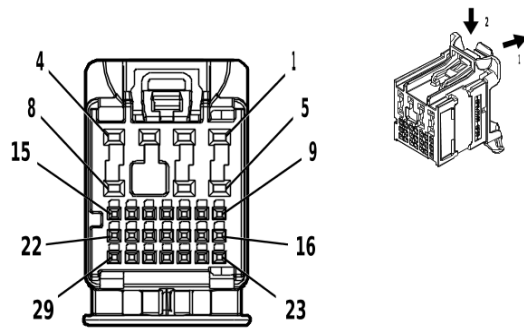

4584346

**Connector Part Information**

Harness Type: Instrument Panel Wiring Harness  
 OEM Connector: 160014-0012  
 Service Connector: 13534972  
 Description: 29-Way F 0.5 NANO, 1.2 MCON Series( GN)

**Terminal Part Information**

Terminal Type ID	Terminated Lead	Diagnostic Test Probe	Terminal Removal Tool
I	19370262	EL-35616-58 (BK)	EL-38125-58
II	84729890	J-35616-12 (BU)	J-38125-215A

**A11 Radio X1 (IOR)**

Pin	Size	Color	Circuit	Function	Terminal Type ID	Option
1	0.75	RD / GY	2840	Battery Positive Voltage	II	—
2	0.75	RD / GY	2840	Battery Positive Voltage	II	—
3	0.75	BK / WH	1051	Signal Ground	II	—
4	0.35	BU / RD	11246	Infotainment Display 5 Volt Reference	II	—
5	0.35	BK / WH	11252	Infotainment Display Low Reference	II	—
6	0.75	BK / WH	1051	Signal Ground	II	—
7	—	—	—	Not Occupied	—	—
8	0.75	GN / BK	116	Left Rear Speaker [-] Control	II	—
9	0.35	GY / BU	11247	Infotainment Display LCD Enable Signal	I	—
10	—	—	—	Not Occupied	—	—
11	0.35	GN / WH	24	Backup Lamp Control	I	—
12 - 14	—	—	—	Not Occupied	—	—
15	0.35	BU / GY	11244	Radio Switch Dimming Control	I	—
16	—	—	—	Not Occupied	—	—
17	0.35	BU / WH	4985	AUTOSAR CAN Bus [+] 5 Serial Data	I	—
18	0.35	BU / YE	4984	AUTOSAR CAN Bus [-] 5 Serial Data	I	—
19 - 20	—	—	—	Not Occupied	—	—
21	0.35	GY / VT	11249	Infotainment Display Backlight Enable Control	I	—
22	0.35	BU / GN	11248	Infotainment Display Backlight Dimming Control	I	—
23	—	—	—	Not Occupied	—	—
24	0.35	BN / WH	11233	Radio Switch Power ON/OFF Switch Signal	I	—

**A11 Radio X1 (IOR) (cont'd)**

<b>Pin</b>	<b>Size</b>	<b>Color</b>	<b>Circuit</b>	<b>Function</b>	<b>Terminal Type ID</b>	<b>Option</b>
25	0.35	VT / WH	11245	Radio Switch Buttons Signal	I	—
26	0.35	BU	11235	Radio Switch Volume Up Signal	I	—
27	0.35	GY / BN	11234	Radio Switch Volume Down Signal	I	—
28 - 29	—	—	—	Not Occupied	—	—

**A11 Radio X2 (IOK)**

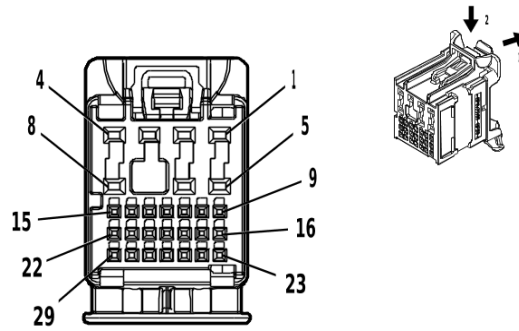

4578560

**Connector Part Information**

Harness Type: Instrument Panel Wiring Harness  
 OEM Connector: 160014-0011  
 Service Connector: 13534971  
 Description: 29-Way F 0.5 NANO, 1.2 MCON, stAK50h Series( GY)

**Terminal Part Information**

Terminal Type ID	Terminated Lead	Diagnostic Test Probe	Terminal Removal Tool
I	19370262	EL-35616-58 (BK)	EL-38125-58
II	84729890	J-35616-12 (BU)	J-38125-215A

**A11 Radio X2 (IOK)**

Pin	Size	Color	Circuit	Function	Terminal Type ID	Option
1	0.75	GN	199	Left Rear Speaker [+] Control	II	—
2	0.75	BU	201	Left Front Speaker 1 [+] Control	II	—
3	0.75	YE / BK	117	Right Front Speaker [-] Control 1	II	—
4	0.75	BU / BK	115	Right Rear Speaker [-] Control	II	—
5	0.75	BN / BU	118	Left Front Speaker [-] Control 1	II	—
6	0.75	YE	200	Right Front Speaker 1 [+] Control	II	—
7	—	—	—	Not Occupied	—	—
8	0.75	WH	46	Right Rear Speaker [+] Control	II	—
9	0.35	BU / WH	4985	AUTOSAR CAN Bus [+] 5 Serial Data	I	—
10	0.35	BU / YE	4984	AUTOSAR CAN Bus [-] 5 Serial Data	I	—
11 - 12	—	—	—	Not Occupied	—	—
13	0.35	GN / WH	24	Backup Lamp Control	I	—
14 - 29	—	—	—	Not Occupied	—	—

### A11 Radio X2 (IOR)

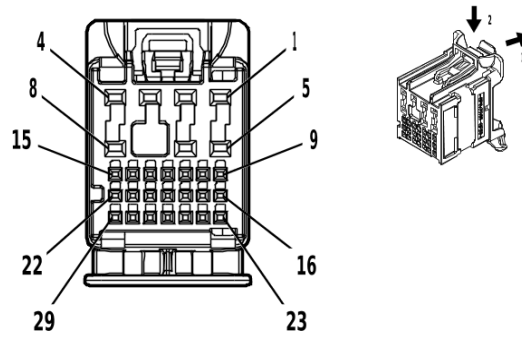

4584398

#### Connector Part Information

Harness Type: Instrument Panel Wiring Harness  
 OEM Connector: 160014-0013  
 Service Connector: 13534973  
 Description: 29-Way F 0.5 NANO, 1.2 MCON, stAK50h Series( GY)

#### Terminal Part Information

Terminal Type ID	Terminated Lead	Diagnostic Test Probe	Terminal Removal Tool
I	19370262	EL-35616-58 (BK)	EL-38125-58
II	84729890	J-35616-12 (BU)	J-38125-215A

#### A11 Radio X2 (IOR)

Pin	Size	Color	Circuit	Function	Terminal Type ID	Option
1	0.75	GN	199	Left Rear Speaker [+] Control	II	—
2	0.75	BU	201	Left Front Speaker 1 [+] Control	II	—
3	0.75	YE	200	Right Front Speaker 1 [+] Control	II	—
4	0.75	BU / BK	115	Right Rear Speaker [-] Control	II	—
5	0.75	BN / BU	118	Left Front Speaker [-] Control 1	II	—
6	0.75	YE / BK	117	Right Front Speaker [-] Control 1	II	—
7	—	—	—	Not Occupied	—	—
8	0.75	WH	46	Right Rear Speaker [+] Control	II	—
9	0.35	BK / BN	654	Cellular Telephone Microphone Low Reference	I	UE0
	0.35	BK / GY	5152	Voice Recognition Audio [-] Control	I	UE1/ UDA
10	0.35	BU	655	Cellular Telephone Microphone Signal	I	UE0
	0.35	GY / YE	5149	Voice Recognition Audio Signal	I	UE1/ UDA
11 - 29	—	—	—	Not Occupied	—	—

**A11 Radio X3 (IOK)**

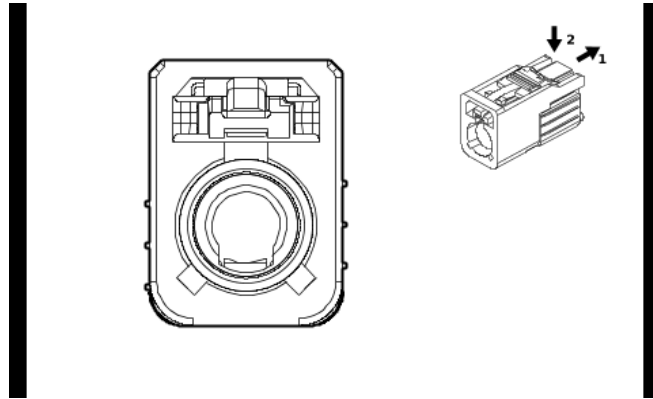

5794617

**Connector Part Information**

Harness Type: Instrument Panel Wiring Harness COAX  
 OEM Connector: 33340318  
 Service Connector: Service by Cable Assembly — See Part Catalog  
 Description: 1-Way F Coax Type( CU)

**Terminal Part Information**

Terminal Type ID	Terminated Lead	Diagnostic Test Probe	Terminal Removal Tool
I	Not required	No Tool Required	No Tool Required

**A11 Radio X3 (IOK)**

Pin	Size	Color	Circuit	Function	Terminal Type ID	Option
—	—	Coax Cable	—	(XM +/-HD) Coaxial Antenna XM Signal	I	—

**A11 Radio X3 (IOR)**

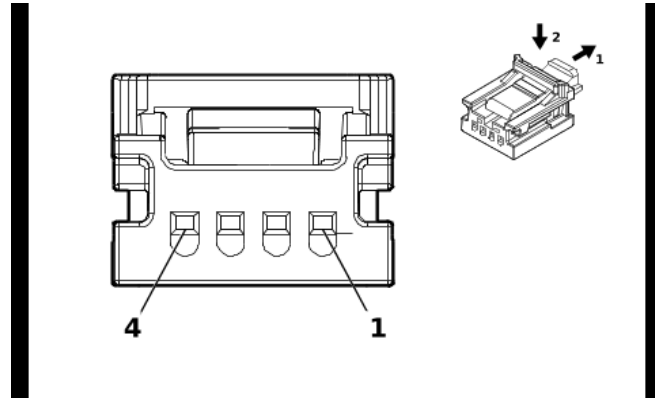

5493278

**Connector Part Information**

Harness Type: Instrument Panel Wiring Harness  
 OEM Connector: 34791-5140  
 Service Connector: 19354840  
 Description: 4-Way F Mini 50 Series( BK)

**Terminal Part Information**

Terminal Type ID	Terminated Lead	Diagnostic Test Probe	Terminal Removal Tool
I	Service by Cable	No Tool Required	No Tool Required

**A11 Radio X3 (IOR)**

Pin	Size	Color	Circuit	Function	Terminal Type ID	Option
1	—	—	—	Not Occupied	—	—
2	0.35	YE	4758	Ethernet Bus 2 [+]	I	—
3	0.35	BU	4757	Ethernet Bus 2 [-]	I	—
4	—	—	—	Not Occupied	—	—

**A11 Radio X4 (IOK)**

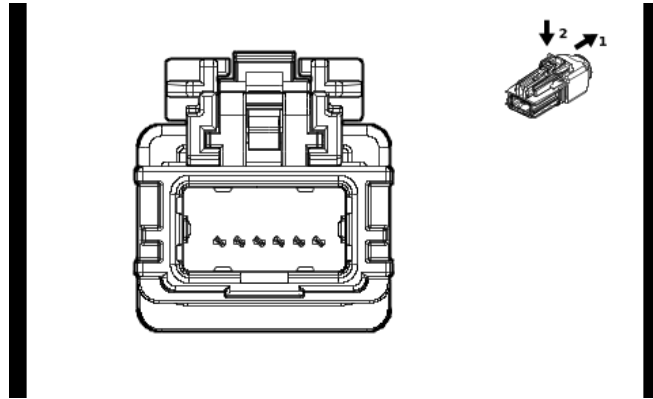

5987912

**Connector Part Information**

Harness Type: Instrument Panel Wiring Harness USB  
 OEM Connector: 111146-7050  
 Service Connector: Service by Cable Assembly — See Part Catalog  
 Description: 12-Way M 2.0 HSAL-2 Series( BK)

**Terminal Part Information**

Terminal Type ID	Terminated Lead	Diagnostic Test Probe	Terminal Removal Tool
I	Not required	No Tool Required	No Tool Required

**A11 Radio X4 (IOK)**

Pin	Size	Color	Circuit	Function	Terminal Type ID	Option
—	—	USB	—	USB Serial Data	I	—



## A11 Radio X4 (IOR)

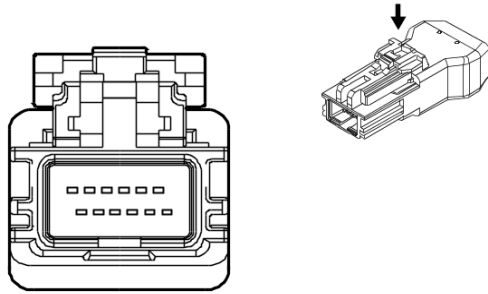

4527210

### Connector Part Information

Harness Type: Instrument Panel Wiring Harness  
 OEM Connector: 111146-3000  
 Service Connector: Service by Cable Assembly — See Part Catalog  
 Description: 12-Way M 2.0 HSAL-2 Series( BK)

### Terminal Part Information

Terminal Type ID	Terminated Lead	Diagnostic Test Probe	Terminal Removal Tool
I	Not required	No Tool Required	No Tool Required

### A11 Radio X4 (IOR)

Pin	Size	Color	Circuit	Function	Terminal Type ID	Option
1	0	—	4844	Radio LVDS (Low Voltage Differential Signaling) Low Reference	I	—
2	0	—	4845	Radio LVDS (Low Voltage Differential Signaling) Signal [+]	I	—
3	0	—	4846	Radio LVDS (Low Voltage Differential Signaling) Signal [-]	I	—
4 - 6	—	—	—	Not Occupied	—	—
7	0	—	7899	Auxiliary Audio/Video Jack USB Serial Data Supply Voltage	I	—
8	—	—	—	Not Occupied	—	—
9	0	—	7896	Auxiliary Audio/Video Jack USB [+] Serial Data	I	—
10	0	—	7897	Auxiliary Audio/Video Jack USB [-] Serial Data	I	—
11	—	—	—	Not Occupied	—	—
12	0	—	7898	Auxiliary Audio/Video Jack USB Low Reference	I	—

**A11 Radio X5 (IOK)**

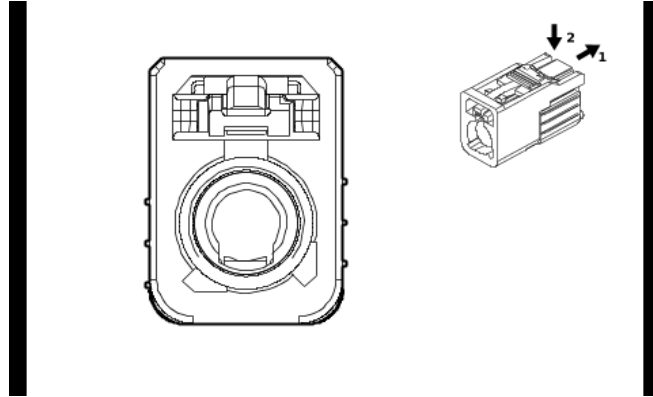

5191842

**Connector Part Information**

Harness Type: Instrument Panel Wiring Harness COAX  
 OEM Connector: 33340320  
 Service Connector: Service by Cable Assembly — See Part Catalog  
 Description: 1-Way F Coax Type( OG)

**Terminal Part Information**

Terminal Type ID	Terminated Lead	Diagnostic Test Probe	Terminal Removal Tool
I	Not required	No Tool Required	No Tool Required

**A11 Radio X5 (IOK)**

Pin	Size	Color	Circuit	Function	Terminal Type ID	Option
—	—	Coax Cable	—	Video Processing Module Coaxial Video Signal	I	—

**A11 Radio X5 (IOR)**

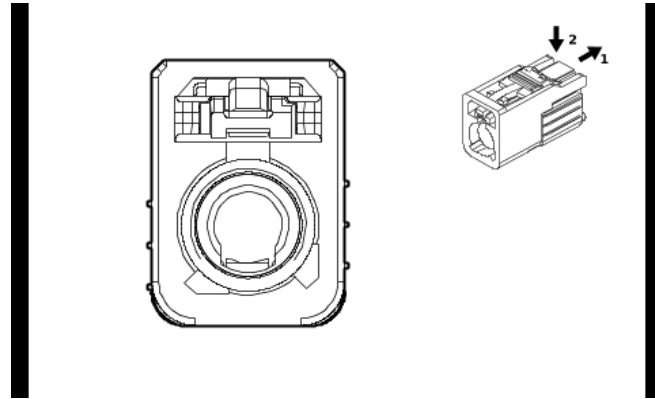

5191842

**Connector Part Information**

Harness Type: Instrument Panel Wiring Harness COAX  
 OEM Connector: 33340320  
 Service Connector: Service by Cable Assembly — See Part Catalog  
 Description: 1-Way F Coax Type( OG)

**Terminal Part Information**

Terminal Type ID	Terminated Lead	Diagnostic Test Probe	Terminal Removal Tool
I	Not required	No Tool Required	No Tool Required

**A11 Radio X5 (IOR)**

Pin	Size	Color	Circuit	Function	Terminal Type ID	Option
—	—	Coax Cable	—	Rear Vision Camera Coaxial Video Signal	I	—

A11 Radio X6 (IOK)

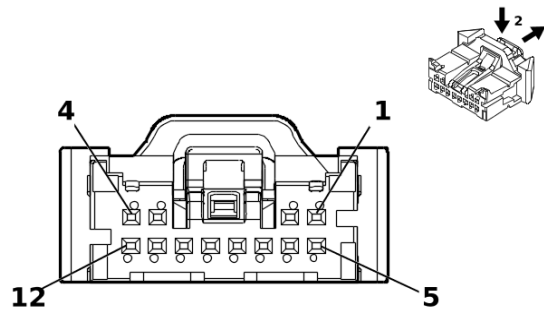

5360826

**Connector Part Information**

Harness Type: Instrument Panel Wiring Harness  
 OEM Connector: 35068239  
 Service Connector: 13529935  
 Description: 12-Way F 050 CTS Series( BK)

**Terminal Part Information**

Terminal Type ID	Terminated Lead	Diagnostic Test Probe	Terminal Removal Tool
I	Not required	No Tool Required	No Tool Required
II	Service by Cable	No Tool Required	No Tool Required

**A11 Radio X6 (IOK)**

Pin	Size	Color	Circuit	Function	Terminal Type ID	Option
1	—	GN	199	Left Rear Speaker [+] Control	I	—
2	—	BU	201	Left Front Speaker 1 [+] Control	I	—
3	0.35	YE / BK	117	Right Front Speaker [-] Control 1	I	—
		YE	4758	Ethernet Bus 2 [+]	II	—
4	0.35	BU / BK	115	Right Rear Speaker [-] Control	I	—
		BU	4757	Ethernet Bus 2 [-]	II	—
5	—	BN / BU	118	Left Front Speaker [-] Control 1	I	—
6	—	YE	200	Right Front Speaker 1 [+] Control	I	—
7	—	—	—	Not Occupied	—	—
8	0.35	WH	46	Right Rear Speaker [+] Control	I	—
		YE	7215	Ethernet Bus 6 [+]	II	—
9	0.35	BU / WH	4985	AUTOSAR CAN Bus [+] 5 Serial Data	I	—
		GN	7214	Ethernet Bus 6 [-]	II	—
10	—	BU / YE	4984	AUTOSAR CAN Bus [-] 5 Serial Data	I	—
11	0.35	BN	7211	Ethernet Bus 4 [+]	II	—
12	0.35	GY	7210	Ethernet Bus 4 [-]	II	—
13	—	GN / WH	24	Backup Lamp Control	I	—

**A11 Radio X6 (IOR)**

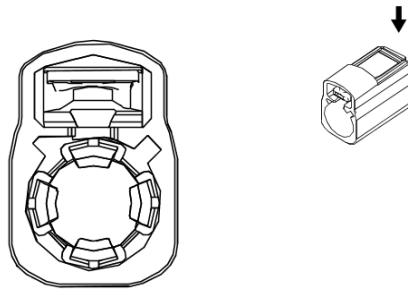

2908476

**Connector Part Information**

Harness Type: Radio Antenna Cable Extension Cable COAX  
 OEM Connector: 12784257  
 Service Connector: Service by Cable Assembly — See Part Catalog  
 Description: 1-Way F Coax Type( BK)

**Terminal Part Information**

Terminal Type ID	Terminated Lead	Diagnostic Test Probe	Terminal Removal Tool
I	Not required	No Tool Required	No Tool Required

**A11 Radio X6 (IOR)**

Pin	Size	Color	Circuit	Function	Terminal Type ID	Option
—	—	Coax Cable	—	(AM/FM) Antenna RF Signal	I	—

**A11 Radio X7 (IOK)**

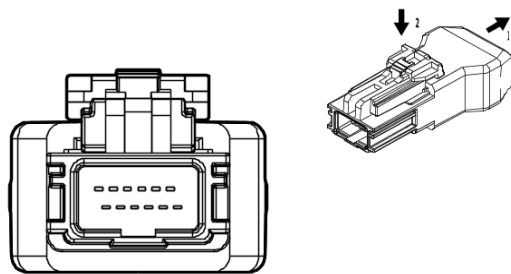

4584321

**Connector Part Information**

Harness Type: Instrument Panel Wiring Harness  
 OEM Connector: 111146-7100  
 Service Connector: Service by Cable Assembly — See Part Catalog  
 Description: 12-Way M 2.0 HSAL-2 Series( GY)

**Terminal Part Information**

Terminal Type ID	Terminated Lead	Diagnostic Test Probe	Terminal Removal Tool
I	Not required	No Tool Required	No Tool Required

**A11 Radio X7 (IOK)**

Pin	Size	Color	Circuit	Function	Terminal Type ID	Option
1	0	—	7853	Center Stack LVDS (Low Voltage Differential Signaling) Low Reference	I	—
2	0	—	7854	Center Stack LVDS (Low Voltage Differential Signaling) Signal [+]	I	—
3	0	—	7855	Center Stack LVDS (Low Voltage Differential Signaling) Signal [-]	I	—
4	0	—	7847	Center Stack LVDS (Low Voltage Differential Signaling) 2 Low Reference	I	—
5	0	—	7848	Center Stack LVDS (Low Voltage Differential Signaling) 2 Signal [+]	I	—
6	0	—	7849	Center Stack LVDS (Low Voltage Differential Signaling) 2 Signal [-]	I	—
7 - 12	—	—	—	Not Occupied	—	—

**A11 Radio X7 (IOR)**

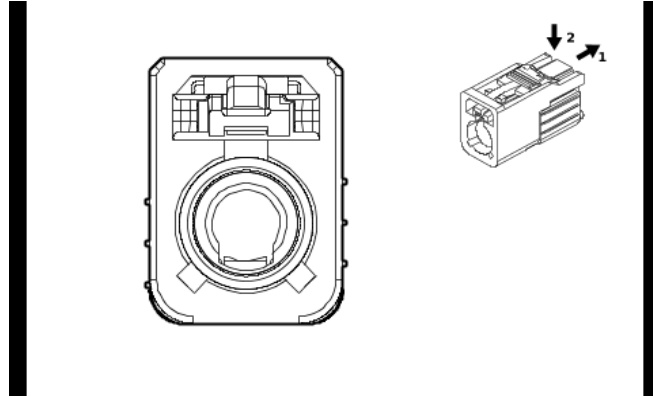

5794617

**Connector Part Information**

Harness Type: Instrument Panel Wiring Harness COAX  
 OEM Connector: 33340318  
 Service Connector: Service by Cable Assembly — See Part Catalog  
 Description: 1-Way F Coax Type( CU)

**Terminal Part Information**

Terminal Type ID	Terminated Lead	Diagnostic Test Probe	Terminal Removal Tool
I	Not required	No Tool Required	No Tool Required

**A11 Radio X7 (IOR)**

Pin	Size	Color	Circuit	Function	Terminal Type ID	Option
—	—	Coax Cable	—	(XM +/-HD) Coaxial Antenna XM Signal	I	—

**A11 Radio X8 (IOK)**

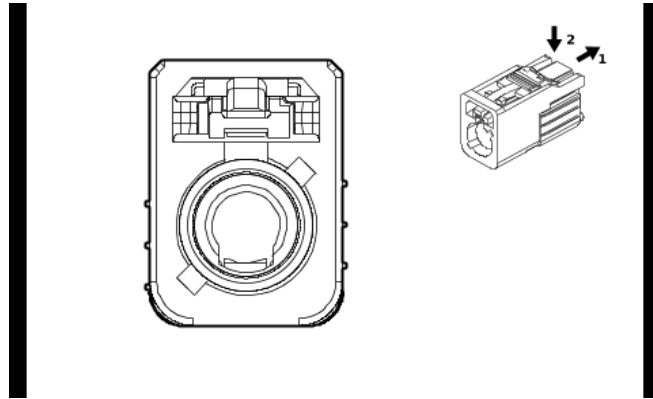

5793980

**Connector Part Information**

Harness Type: Instrument Panel Wiring Harness COAX  
 OEM Connector: 33340311  
 Service Connector: Service by Cable Assembly — See Part Catalog  
 Description: 1-Way F Coax Type( BU)

**Terminal Part Information**

Terminal Type ID	Terminated Lead	Diagnostic Test Probe	Terminal Removal Tool
I	Not required	No Tool Required	No Tool Required

**A11 Radio X8 (IOK)**

Pin	Size	Color	Circuit	Function	Terminal Type ID	Option
—	—	Coax Cable	—	(GPS only) Coaxial Antenna GPS Signal	I	—



**A11 Radio X8 (IOR)**

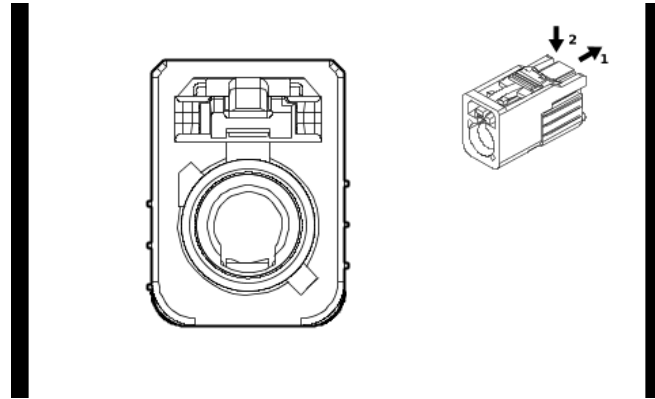

5518456

**Connector Part Information**

Harness Type: Instrument Panel Wiring Harness COAX  
 OEM Connector: 33340317  
 Service Connector: Service by Cable Assembly — See Part Catalog  
 Description: 1-Way F Coax Type( BG)

**Terminal Part Information**

Terminal Type ID	Terminated Lead	Diagnostic Test Probe	Terminal Removal Tool
I	Not required	No Tool Required	No Tool Required

**A11 Radio X8 (IOR)**

Pin	Size	Color	Circuit	Function	Terminal Type ID	Option
—	—	Coax Cable	—	WiFi Antenna Coaxial Signal	I	—

**A11 Radio X9**

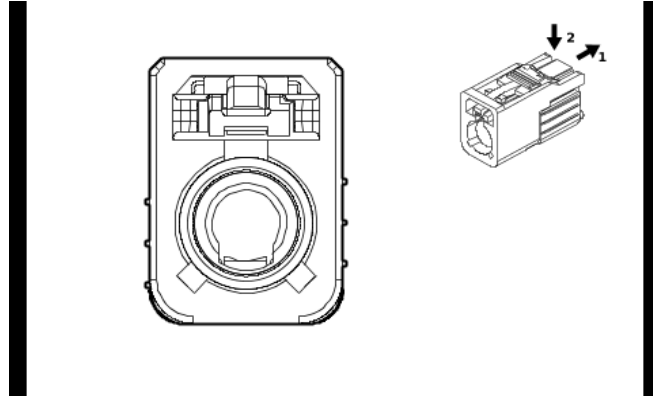

5794617

**Connector Part Information**

Harness Type: Instrument Panel Wiring Harness COAX  
 OEM Connector: 33340318  
 Service Connector: Service by Cable Assembly — See Part Catalog  
 Description: 1-Way F Coax Type( CU)

**Terminal Part Information**

Terminal Type ID	Terminated Lead	Diagnostic Test Probe	Terminal Removal Tool
I	Not required	No Tool Required	No Tool Required

**A11 Radio X9**

Pin	Size	Color	Circuit	Function	Terminal Type ID	Option
—	—	Coax Cable	—	(XM +/-HD) Coaxial Antenna XM Signal	I	—

**A11 Radio X11**

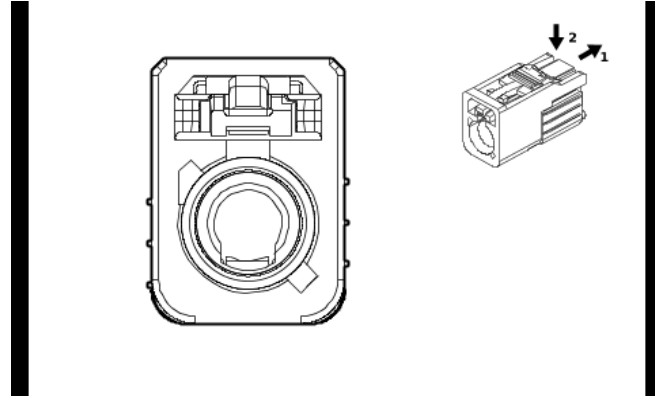

5518456

**Connector Part Information**

Harness Type: Instrument Panel Wiring Harness COAX  
 OEM Connector: 33340317  
 Service Connector: Service by Cable Assembly — See Part Catalog  
 Description: 1-Way F Coax Type( BG)

**Terminal Part Information**

Terminal Type ID	Terminated Lead	Diagnostic Test Probe	Terminal Removal Tool
I	Not required	No Tool Required	No Tool Required

**A11 Radio X11**

Pin	Size	Color	Circuit	Function	Terminal Type ID	Option
—	—	Coax Cable	—	WiFi Antenna Coaxial Signal	I	—

**A16 Transfer Case Four Wheel Drive Actuator (NP0 / NQH)**

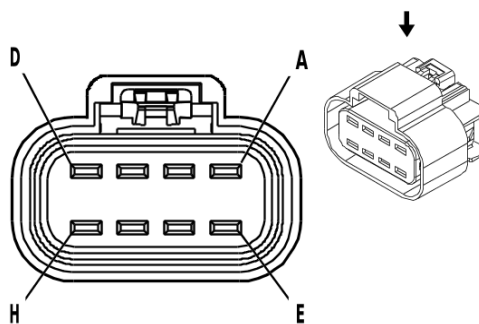

646372

**Connector Part Information**

Harness Type: Engine Wiring Harness  
 OEM Connector: 13538370  
 Service Connector: 19369184  
 Description: 8-Way F 280 GT Series, Sealed( BK)

**Terminal Part Information**

Terminal Type ID	Terminated Lead	Diagnostic Test Probe	Terminal Removal Tool
I	Not required	J-35616-4A (PU)	No Tool Required

**A16 Transfer Case Four Wheel Drive Actuator (NP0 / NQH)**

Pin	Size	Color	Circuit	Function	Terminal Type ID	Option
A	2.5	YE / GY	1552	Transfer Case Motor Clockwise Control	I	—
B	0.75	BU	8013	Transfer Case Lock Solenoid Control 2	I	—
C	0.75	YE / BN	1569	Transfer Case Lock Solenoid Valve Control	I	—
D	2.5	YE / VT	1553	Transfer Case Motor Counter Clockwise Control	I	—
E	0.5	YE	7474	Incremental Encoder Direction Signal	I	—
F	0.5	BU / GY	7473	Incremental Encoder Impulse Signal	I	—
G	0.5	WH / GN	7475	Incremental Encoder Sensor Voltage Reference	I	—
H	0.5	VT	7476	Incremental Encoder Sensor Low Reference	I	—

**A22 Radio Control X1**

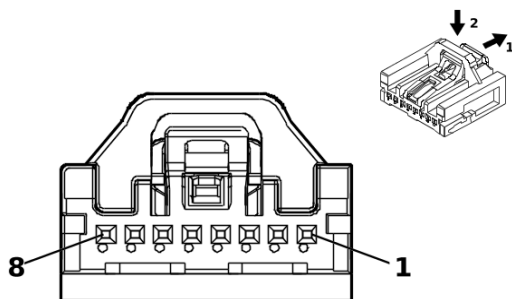

5200269

**Connector Part Information**

Harness Type: Instrument Panel Wiring Harness  
 OEM Connector: 35068228  
 Service Connector: 84769201  
 Description: 8-Way F Mini 50 Series( BK)

**Terminal Part Information**

Terminal Type ID	Terminated Lead	Diagnostic Test Probe	Terminal Removal Tool
I	Not required	EL-35616-58 (BK)	No Tool Required

**A22 Radio Control X1**

Pin	Size	Color	Circuit	Function	Terminal Type ID	Option
1	0.35	RD / WH	1340	Battery Positive Voltage	I	—
2 - 7	—	—	—	Not Occupied	—	—
8	0.35	BK / WH	1051	Signal Ground	I	—

**A22 Radio Control X2**

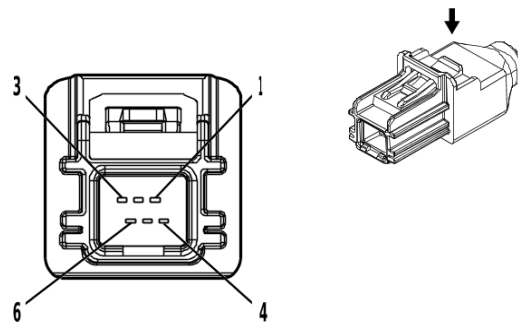

4806625

**Connector Part Information**

Harness Type: Instrument Panel Wiring Harness  
 OEM Connector: 100337-1020  
 Service Connector: Service by Cable Assembly — See Part Catalog  
 Description: 6-Way M HSAL-2 Series( BK)

**Terminal Part Information**

Terminal Type ID	Terminated Lead	Diagnostic Test Probe	Terminal Removal Tool
I	Not required	No Tool Required	No Tool Required

**A22 Radio Control X2**

Pin	Size	Color	Circuit	Function	Terminal Type ID	Option
1	0	—	7853	Center Stack LVDS (Low Voltage Differential Signaling) Low Reference	I	—
2	0	—	7854	Center Stack LVDS (Low Voltage Differential Signaling) Signal [+]	I	—
3	0	—	7855	Center Stack LVDS (Low Voltage Differential Signaling) Signal [-]	I	—
4	0	—	7848	Center Stack LVDS (Low Voltage Differential Signaling) 2 Signal [+]	I	—
5	0	—	7849	Center Stack LVDS (Low Voltage Differential Signaling) 2 Signal [-]	I	—
6	0	—	7847	Center Stack LVDS (Low Voltage Differential Signaling) 2 Low Reference	I	—

**A23D Front Side Door Latch - Driver**

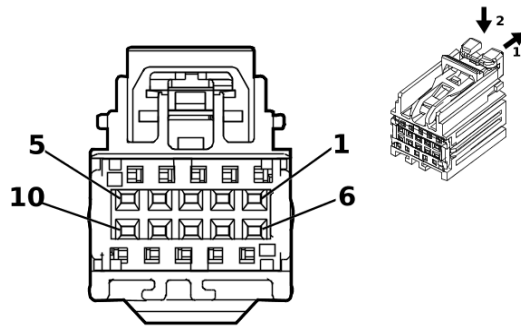

4622549

**Connector Part Information**

Harness Type: Front Side Door Door Wiring Harness - Driver  
 OEM Connector: 7289-5068-60  
 Service Connector: Service by Harness - See Part Catalog  
 Description: 10-Way F 0.64 Kaizen Series( GN)

**Terminal Part Information**

Terminal Type ID	Terminated Lead	Diagnostic Test Probe	Terminal Removal Tool
I	Not required	J-35616-64B (L-BU)	No Tool Required

**A23D Front Side Door Latch - Driver**

Pin	Size	Color	Circuit	Function	Terminal Type ID	Option
1	0.5	GY	745	Left Front Door Ajar Switch Signal	I	—
2	0.5	VT / GY	126	Left Front Door Open Switch Signal	I	—
3	0.5	BK	1550	Ground	I	—
4	0.5	WH / VT	4258	Left Front Door Lock Status Signal	I	—
5 - 6	—	—	—	Not Occupied	—	—
7	0.75	GY	2681	Left Front Door Lock Actuator Lock Control	I	—
8	0.75	WH	2679	Lock Actuators Unlock Control 1	I	—
9 - 10	—	—	—	Not Occupied	—	—

**A23LR Rear Side Door Latch - Left**

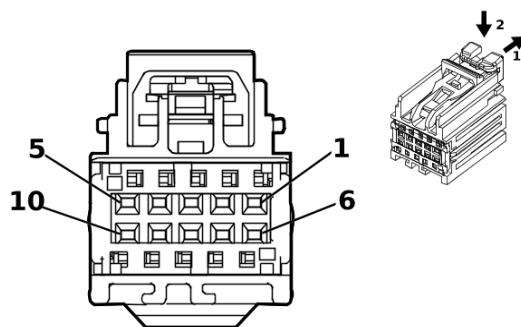

4622549

**Connector Part Information**

Harness Type: Rear Side Door Door Wiring Harness - Left Rear  
 OEM Connector: 7289-5068-60  
 Service Connector: Service by Harness - See Part Catalog  
 Description: 10-Way F 0.64 Kaizen Series( GN)

**Terminal Part Information**

Terminal Type ID	Terminated Lead	Diagnostic Test Probe	Terminal Removal Tool
I	Not required	J-35616-64B (L-BU)	No Tool Required

**A23LR Rear Side Door Latch - Left**

Pin	Size	Color	Circuit	Function	Terminal Type ID	Option
1	0.5	GY	747	Left Rear Door Ajar Switch Signal	I	—
2	—	—	—	Not Occupied	—	—
3	0.5	BK	1550	Ground	I	—
4 - 6	—	—	—	Not Occupied	—	—
7	0.75	BU / YE	1091	Left Rear Door Lock Actuator Lock Control	I	—
8	0.75	WH	2679	Lock Actuators Unlock Control 1	I	—
9 - 10	—	—	—	Not Occupied	—	—



**A23P Front Side Door Latch - Passenger - Double Cab / Crew Cab**

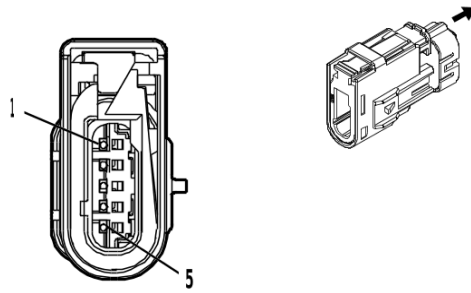

4808321

**Connector Part Information**

Harness Type: Front Side Door Door Wiring Harness - Passenger  
 OEM Connector: 35028909  
 Service Connector: Service by Harness - See Part Catalog  
 Description: 5-Way M 1.2 Series, Sealed( NA)

**Terminal Part Information**

Terminal Type ID	Terminated Lead	Diagnostic Test Probe	Terminal Removal Tool
I	Not required	J-35616-17 (L-GN)	No Tool Required

**A23P Front Side Door Latch - Passenger - Double Cab / Crew Cab**

Pin	Size	Color	Circuit	Function	Terminal Type ID	Option
1	0.5	GY / VT	2676	Right Front Door Exterior Switch Unlock Signal	I	—
2	0.5	GN / YE	4303	Passive Entry Right Antenna Signal High	I	—
3	—	—	—	Not Occupied	—	—
4	0.5	GN / BK	4304	Passive Entry Right Antenna Signal Low	I	—
5	0.5	BK / WH	1451	Signal Ground	I	—

**A23P Front Side Door Latch - Passenger - Regular Cab**

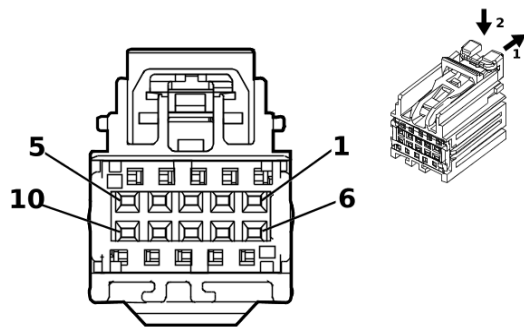

4622549

**Connector Part Information**

Harness Type: Front Side Door Door Wiring Harness - Passenger  
 OEM Connector: 7289-5068-60  
 Service Connector: Service by Harness - See Part Catalog  
 Description: 10-Way F 0.64 Kaizen Series( GN)

**Terminal Part Information**

Terminal Type ID	Terminated Lead	Diagnostic Test Probe	Terminal Removal Tool
I	Not required	J-35616-64B (L-BU)	No Tool Required

**A23P Front Side Door Latch - Passenger - Regular Cab**

Pin	Size	Color	Circuit	Function	Terminal Type ID	Option
1 - 2	—	—	—	Not Occupied	—	—
3	0.5	BK	1350	Ground	I	—
4	—	—	—	Not Occupied	—	—
5	0.5	GY	746	Right Front Door Ajar Switch Signal	I	—
6 - 7	—	—	—	Not Occupied	—	—
8	0.75	GY / BK	2680	Lock Actuators Unlock Control 2	I	—
9	0.75	YE / GN	2682	Right Front Door Lock Actuator Lock Control	I	—
10	—	—	—	Not Occupied	—	—

## A23RR Rear Side Door Latch - Right

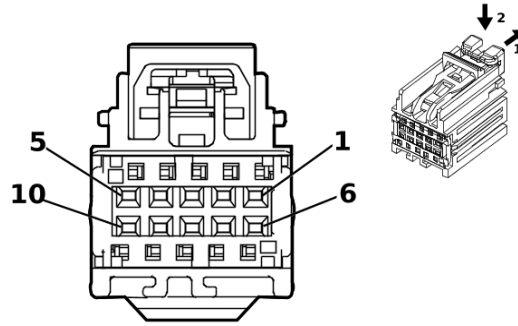

4622549

### Connector Part Information

Harness Type: Rear Side Door Door Wiring Harness - Right Rear  
 OEM Connector: 7289-5068-60  
 Service Connector: Service by Harness - See Part Catalog  
 Description: 10-Way F 0.64 Kaizen Series( GN)

### Terminal Part Information

Terminal Type ID	Terminated Lead	Diagnostic Test Probe	Terminal Removal Tool
I	Not required	J-35616-64B (L-BU)	No Tool Required

### A23RR Rear Side Door Latch - Right

Pin	Size	Color	Circuit	Function	Terminal Type ID	Option
1 - 2	—	—	—	Not Occupied	—	—
3	0.5	BK	1350	Ground	I	—
4	—	—	—	Not Occupied	—	—
5	0.5	GY	748	Right Rear Door Ajar Switch Signal	I	—
6 - 7	—	—	—	Not Occupied	—	—
8	0.75	GY / BK	2680	Lock Actuators Unlock Control 2	I	—
9	0.75	VT / WH	1094	Right Rear Door Lock Actuator Lock Control	I	—
10	—	—	—	Not Occupied	—	—

**A24D Front Side Door Outside Handle - Left**

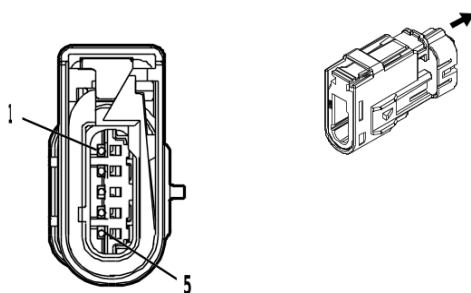

4808321

**Connector Part Information**

Harness Type: Front Side Door Door Wiring Harness - Driver  
 OEM Connector: SRVWSB-04A-BS  
 Service Connector: Service by Harness - See Part Catalog  
 Description: 5-Way M 1.2 Series, Sealed( NA)

**Terminal Part Information**

Terminal Type ID	Terminated Lead	Diagnostic Test Probe	Terminal Removal Tool
I	Not required	J-35616-13 (BU)	No Tool Required

**A24D Front Side Door Outside Handle - Left**

Pin	Size	Color	Circuit	Function	Terminal Type ID	Option
1	0.5	BU	2675	Left Front Exterior Door Handle Switch Unlock Signal	I	—
2	0.5	VT	4301	Passive Entry Left Antenna Signal High	I	—
3	—	—	—	Not Occupied	—	—
4	0.5	VT / GY	4302	Passive Entry Left Antenna Signal Low	I	—
5	0.5	BK / WH	1551	Signal Ground	I	—

**A24P Front Side Door Outside Handle - Right - Double Cab / Crew Cab**

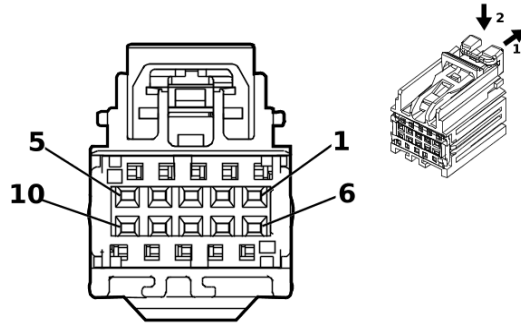

4622549

**Connector Part Information**

Harness Type: Front Side Door Door Wiring Harness - Passenger  
 OEM Connector: 33320811  
 Service Connector: Service by Harness - See Part Catalog  
 Description: 10-Way F 0.64 Kaizen Series( GN)

**Terminal Part Information**

Terminal Type ID	Terminated Lead	Diagnostic Test Probe	Terminal Removal Tool
I	Not required	J-35616-64B (L-BU)	No Tool Required

**A24P Front Side Door Outside Handle - Right - Right - Double Cab / Crew Cab**

Pin	Size	Color	Circuit	Function	Terminal Type ID	Option
1 - 2	—	—	—	Not Occupied	—	—
3	0.5	BK	1350	Ground	I	—
4	—	—	—	Not Occupied	—	—
5	0.5	GY	746	Right Front Door Ajar Switch Signal	I	—
6 - 7	—	—	—	Not Occupied	—	—
8	0.75	GY / BK	2680	Lock Actuators Unlock Control 2	I	—
9	0.75	YE / GN	2682	Right Front Door Lock Actuator Lock Control	I	—
10	—	—	—	Not Occupied	—	—

**A24P Front Side Door Outside Handle - Right - Regular Cab**

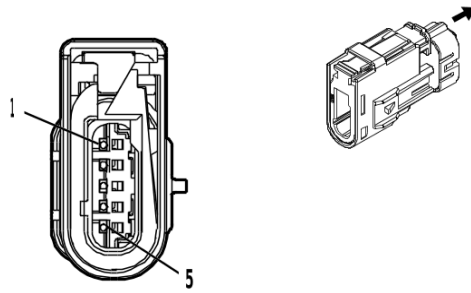

4808321

**Connector Part Information**

Harness Type: Front Side Door Door Wiring Harness - Passenger  
 OEM Connector: SRVWSB-04A-BS  
 Service Connector: Service by Harness - See Part Catalog  
 Description: 5-Way M 1.2 Series, Sealed( NA)

**Terminal Part Information**

Terminal Type ID	Terminated Lead	Diagnostic Test Probe	Terminal Removal Tool
I	Not required	J-35616-13 (BU)	No Tool Required

**A24P Front Side Door Outside Handle - Right - Regular Cab**

Pin	Size	Color	Circuit	Function	Terminal Type ID	Option
1	0.5	GY / VT	2676	Right Front Door Exterior Switch Unlock Signal	I	—
2	0.5	GN / YE	4303	Passive Entry Right Antenna Signal High	I	—
3	—	—	—	Not Occupied	—	—
4	0.5	GN / BK	4304	Passive Entry Right Antenna Signal Low	I	—
5	0.5	BK / WH	1451	Signal Ground	I	—

**A26 Heater and Air Conditioning User Interface Control - Front**

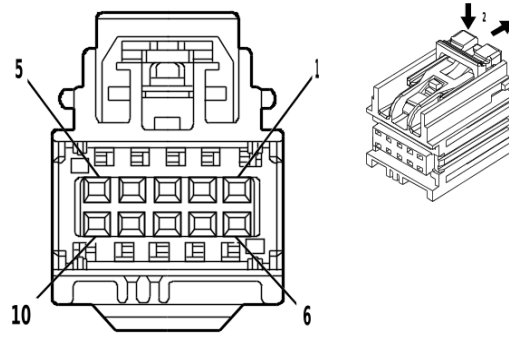

4891168

**Connector Part Information**

Harness Type: Instrument Panel Wiring Harness  
 OEM Connector: 7289-4885  
 Service Connector: 13509649  
 Description: 10-Way F 0.64 Kaizen Series( NA)

**Terminal Part Information**

Terminal Type ID	Terminated Lead	Diagnostic Test Probe	Terminal Removal Tool
I	19300629	J-35616-64B (L-BU)	J-38125-215A

**A26 Heater and Air Conditioning User Interface Control - Front**

Pin	Size	Color	Circuit	Function	Terminal Type ID	Option
1	0.5	RD / WH	1340	Battery Positive Voltage	I	—
2	—	—	—	Not Occupied	—	—
3	0.35	BU / WH	4985	AUTOSAR CAN Bus [+] 5 Serial Data	I	—
4	0.35	BU / WH	4985	AUTOSAR CAN Bus [+] 5 Serial Data	I	—
5	—	—	—	Not Occupied	—	—
6	0.35	GY / GN	4636	HVAC System Enable Signal	I	—
7	—	—	—	Not Occupied	—	—
8	0.35	BU / YE	4984	AUTOSAR CAN Bus [-] 5 Serial Data	I	—
9	0.35	BU / GY	4984	AUTOSAR CAN Bus [-] 5 Serial Data	I	—
10	0.5	BK / WH	851	Signal Ground	I	—

**A38 Reductant Tank Fluid Supply Pump Module (LZ0)**

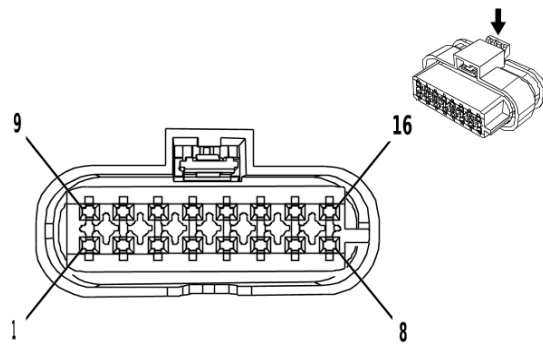

4259227

**Connector Part Information**

Harness Type: Emission Reduction Fluid Tank Reservoir Wire Harness  
 OEM Connector: 33210848  
 Service Connector: Service by Harness - See Part Catalog  
 Description: 16-Way F 1.2 MLK Series, Sealed( BK)

**Terminal Part Information**

Terminal Type ID	Terminated Lead	Diagnostic Test Probe	Terminal Removal Tool
I	Not required	J-35616-16 (L-GN)	No Tool Required
I	Not required	J-35616-16 (L-GN)	No Tool Required

**A38 Reductant Tank Fluid Supply Pump Module (LZ0)**

Pin	Size	Color	Circuit	Function	Terminal Type ID	Option
1	0.5	BK	3244	Diesel Exhaust Fluid Tank Temperature Sensor Signal	I	—
2	0.5	BN	3245	Diesel Exhaust Fluid Tank Temperature Sensor Low Reference	I	—
3	0.5	BU	3107	Diesel Exhaust Fluid Pressure Sensor Low Reference	I	—
4	0.5	BU	3108	Diesel Exhaust Fluid Pressure Sensor Signal	I	—
5	0.5	BN	3106	Diesel Exhaust Fluid Pressure Sensor 5 Volt Reference	I	—
6	—	—	—	Not Occupied	—	—
7	1	WH	3103	Diesel Exhaust Fluid Smart Pump Control	I	—
8	1	BN	3875	Diesel Exhaust Fluid Smart Pump Supply Voltage Phase 2	I	—
9	1	YE	3677	Diesel Exhaust Fluid Reservoir Heater Control	I	—
10	1	BN	3676	Diesel Exhaust Fluid Heating Tank 2 Heater Control	I	—
11	1	BU	4318	Diesel Exhaust Fluid Tank Heater Low Control	I	—
12 - 13	—	—	—	Not Occupied	—	—
14	1	BU	2937	Diesel Exhaust Fluid Pump Motor Stator Low Reference	I	—
15	1	BN	2936	Diesel Exhaust Fluid Heating Tank 2 Heater Control Low	I	—
16	1	YE	3876	Diesel Exhaust Fluid Smart Pump Supply Voltage Phase 3	I	—



### A99L Pickup Box Endgate Latch - Left

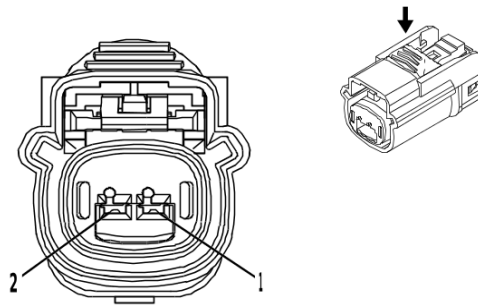

4332222

#### Connector Part Information

Harness Type: Endgate Wiring Harness  
 OEM Connector: 15514573  
 Service Connector: Service by Harness - See Part Catalog  
 Description: 2-Way F 1.5 OCS Series, Sealed( BK)

#### Terminal Part Information

Terminal Type ID	Terminated Lead	Diagnostic Test Probe	Terminal Removal Tool
I	Not required	J-35616-2A (GY)	No Tool Required

#### A99L Pickup Box Endgate Latch - Left

Pin	Size	Color	Circuit	Function	Terminal Type ID	Option
1	1	GN	1299	Major Endgate Motor Control	I	—
2	1	YE / BK	7730	Major Endgate Motor Low Reference	I	—

**A99R Pickup Box Endgate Latch - Right**

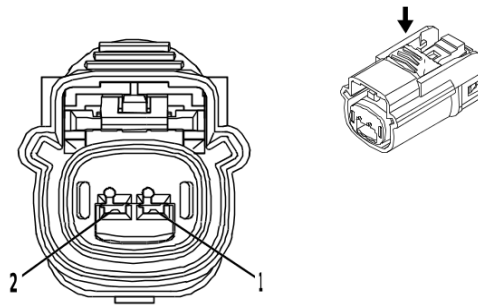

4332222

**Connector Part Information**

Harness Type: Endgate Wiring Harness  
 OEM Connector: 15514573  
 Service Connector: Service by Harness - See Part Catalog  
 Description: 2-Way F 1.5 OCS Series, Sealed( BK)

**Terminal Part Information**

Terminal Type ID	Terminated Lead	Diagnostic Test Probe	Terminal Removal Tool
I	Not required	J-35616-2A (GY)	No Tool Required

**A99R Pickup Box Endgate Latch - Right**

Pin	Size	Color	Circuit	Function	Terminal Type ID	Option
1	1	GN	1299	Major Endgate Motor Control	I	—
2	1	YE / BK	7730	Major Endgate Motor Low Reference	I	—

**A100L Pickup Box Auxiliary Endgate Latch - Left**

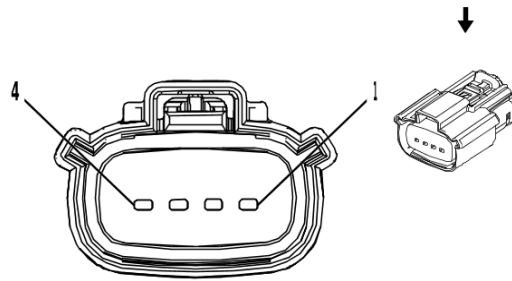

2474747

**Connector Part Information**

Harness Type: Endgate Wiring Harness  
 OEM Connector: 33471-0406  
 Service Connector: Service by Harness - See Part Catalog  
 Description: 4-Way F 1.5 Series, Sealed( BK)

**Terminal Part Information**

Terminal Type ID	Terminated Lead	Diagnostic Test Probe	Terminal Removal Tool
I	Not required	J-35616-2A (GY)	No Tool Required

**A100L Pickup Box Auxiliary Endgate Latch - Left**

Pin	Size	Color	Circuit	Function	Terminal Type ID	Option
1	0.75	YE / BU	7295	Left Minor Endgate Ajar Signal	I	—
2	0.75	BK	1850	Ground	I	—
3	1	YE / BK	7730	Major Endgate Motor Low Reference	I	—
4	1	VT	7725	Minor Endgate Motor Control	I	—

**A100R Pickup Box Auxiliary Endgate Latch - Right**

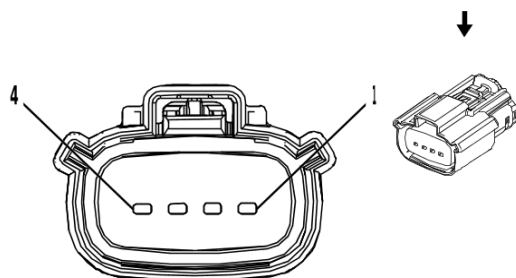

2474747

**Connector Part Information**

Harness Type: Endgate Wiring Harness  
 OEM Connector: 33471-0406  
 Service Connector: Service by Harness - See Part Catalog  
 Description: 4-Way F 1.5 Series, Sealed( BK)

**Terminal Part Information**

Terminal Type ID	Terminated Lead	Diagnostic Test Probe	Terminal Removal Tool
I	Not required	J-35616-2A (GY)	No Tool Required

**A100R Pickup Box Auxiliary Endgate Latch - Right**

Pin	Size	Color	Circuit	Function	Terminal Type ID	Option
1	1	YE / BK	7730	Major Endgate Motor Low Reference	I	—
2	1	VT	7725	Minor Endgate Motor Control	I	—
3 - 4	—	—	—	Not Occupied	—	—

## A103 Roof Console X1

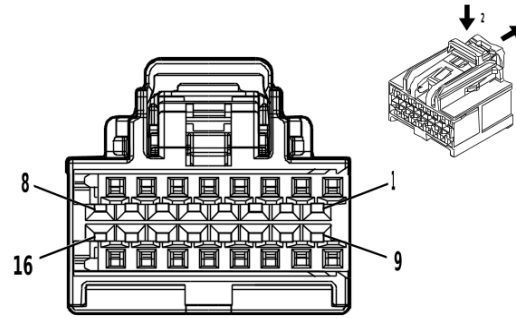

4873254

### Connector Part Information

Harness Type: Dome Lamp Wiring Harness  
 OEM Connector: 35016344  
 Service Connector: 13519739  
 Description: 16-Way F 0.64 OCS Series( GY)

### Terminal Part Information

Terminal Type ID	Terminated Lead	Diagnostic Test Probe	Terminal Removal Tool
I	19300660	J-35616-64B (L-BU)	J-38125-215A

### A103 Roof Console X1

Pin	Size	Color	Circuit	Function	Terminal Type ID	Option
1	0.5	BK	1050	Ground	I	—
2	—	—	—	Not Occupied	—	—
3	0.35	YE	6817	LED Backlight Dimming Control 1	I	—
4 - 6	—	—	—	Not Occupied	—	—
7	0.35	WH / BN	2904	Row 2 Dome Reading Lamp Switch Signal	I	—
8	0.35	VT / GY	2906	Row 2 Dome Reading Lamp 2 Switch Signal	I	—
9	0.5	RD / YE	240	Battery Positive Voltage	I	—
10	0.5	GN / WH	2854	Body Control Module LIN Bus 8	I	—
11	0.35	BU / GN	4785	Interior Lamp Overhead Enable Signal	I	—
12	0.35	GY / WH	2369	Interior Lamp Overhead 2 Enable Signal	I	—
13	0.35	GN / YE	2903	Row 2 Dome Reading Lamp Interior Lamp Control	I	—
14	0.35	BN / BU	2905	Row 2 Dome Reading Lamp 2 Interior Lamp Control	I	—
15	—	—	—	Not Occupied	—	—
16	0.5	BK	1050	Ground	I	—

**A103 Roof Console X2**

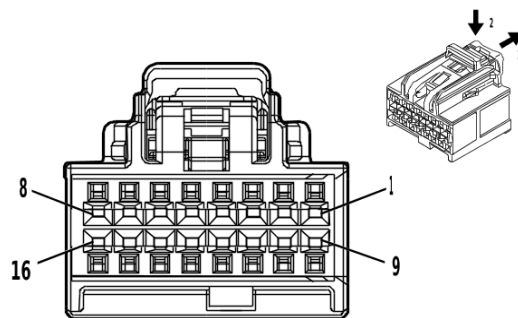

4873243

**Connector Part Information**

Harness Type: Dome Lamp Wiring Harness  
 OEM Connector: 35016343  
 Service Connector: 13519738  
 Description: 16-Way F 0.64 OCS Series( BK)

**Terminal Part Information**

Terminal Type ID	Terminated Lead	Diagnostic Test Probe	Terminal Removal Tool
I	19354230	J-35616-64B (L-BU)	J-38125-215A

**A103 Roof Console X2**

Pin	Size	Color	Circuit	Function	Terminal Type ID	Option
1	0.35	YE / VT	2516	Telematics Switch Green LED Indicator Control	I	—
2	0.35	BN / WH	2517	Telematics Switch Red LED Indicator Control	I	—
3	0.35	GN / WH	2514	Telematics Switch Signal	I	—
4	0.35	GN / BK	2515	Telematics Switch Supply Voltage	I	—
5	0.35	BK / WH	851	Signal Ground	I	—
6	0.35	YE / VT	6191	Power Rear Window Switch Open Signal	I	—
7	0.35	WH	6192	Sliding Rear Window Switch Close Signal	I	—
8	0.5	VT	801	Retained Accessory Power Control	I	—
9 - 16	—	—	—	Not Occupied	—	—

## B1 Air Conditioning Refrigerant Pressure Sensor

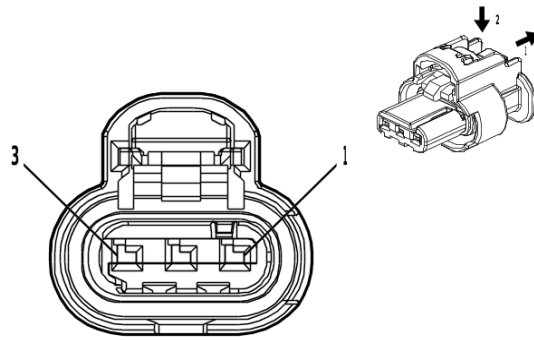

4581126

### Connector Part Information

Harness Type: Engine Wiring Harness  
 OEM Connector: 1-2296695-1  
 Service Connector: 86792094  
 Description: 3-Way F 1.2 MCON-CB Series, Sealed( BK)

### Terminal Part Information

Terminal Type ID	Terminated Lead	Diagnostic Test Probe	Terminal Removal Tool
I	Not required	J-35616-12 (BU)	No Tool Required

### B1 Air Conditioning Refrigerant Pressure Sensor

Pin	Size	Color	Circuit	Function	Terminal Type ID	Option
1	0.5	WH / RD	480	Engine Control Vehicle Sensors 5 Volt Reference 1	I	—
2	0.5	GN	380	Air Conditioning Refrigerant Pressure Sensor Signal	I	—
3	0.5	BK / GY	626	Engine Control Vehicle Sensors Low Reference 1	I	—

**B5LF Front Wheel Speed Sensor - Left**

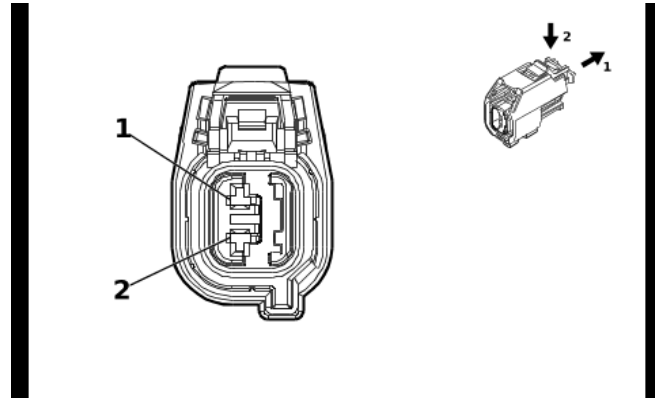

5666214

**Connector Part Information**

Harness Type: Chassis Wiring Harness  
 OEM Connector: 33189092  
 Service Connector: 85526683  
 Description: 2-Way F 1.5 OCS Series, Sealed( GY)

**Terminal Part Information**

Terminal Type ID	Terminated Lead	Diagnostic Test Probe	Terminal Removal Tool
I	Not required	J-35616-14 (GN)	No Tool Required

**B5LF Front Wheel Speed Sensor - Left**

Pin	Size	Color	Circuit	Function	Terminal Type ID	Option
1	0.5	GY / WH	7064	Left Front Wheel Speed Sensor Control	I	—
2	0.5	GY	830	Left Front Wheel Speed Sensor Signal	I	—



## B5LR Rear Wheel Speed Sensor - Left

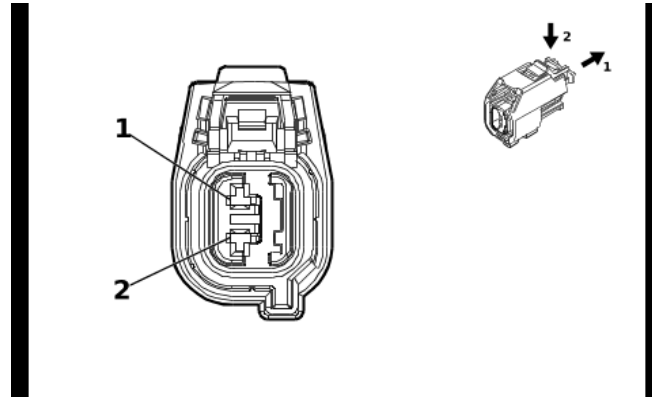

5666214

### Connector Part Information

Harness Type: Chassis Wiring Harness  
 OEM Connector: 33189092  
 Service Connector: 85526683  
 Description: 2-Way F 1.5 OCS Series, Sealed( GY)

### Terminal Part Information

Terminal Type ID	Terminated Lead	Diagnostic Test Probe	Terminal Removal Tool
I	Not required	J-35616-14 (GN)	No Tool Required

### B5LR Rear Wheel Speed Sensor - Left

Pin	Size	Color	Circuit	Function	Terminal Type ID	Option
1	0.5	GY / BK	7127	Left Rear Wheel Speed Sensor Control	I	—
2	0.5	BU	884	Left Rear Wheel Speed Sensor Signal	I	—

**B5RF Front Wheel Speed Sensor - Right**

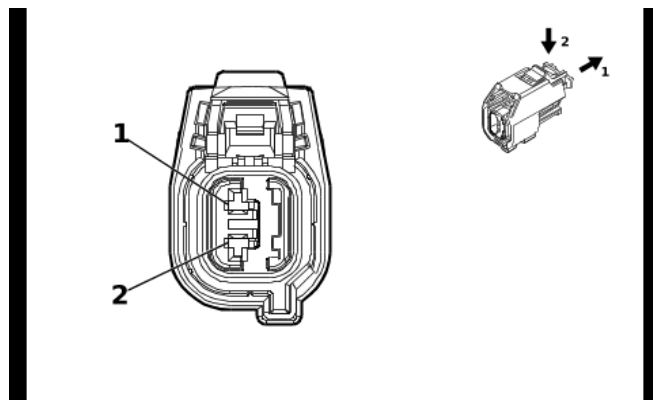

5666214

**Connector Part Information**

Harness Type: Chassis Wiring Harness  
 OEM Connector: 33189092  
 Service Connector: 85526683  
 Description: 2-Way F 1.5 OCS Series, Sealed( GY)

**Terminal Part Information**

Terminal Type ID	Terminated Lead	Diagnostic Test Probe	Terminal Removal Tool
I	Not required	J-35616-14 (GN)	No Tool Required

**B5RF Front Wheel Speed Sensor - Right**

Pin	Size	Color	Circuit	Function	Terminal Type ID	Option
1	0.5	GY / BN	7065	Right Front Wheel Speed Sensor Control	I	—
2	0.5	YE	872	Right Front Wheel Speed Sensor Signal	I	—

## B5RR Rear Wheel Speed Sensor - Right

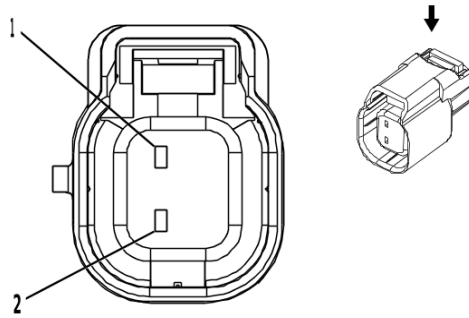

4115616

### Connector Part Information

Harness Type: Chassis Wiring Harness  
 OEM Connector: 34062-0046  
 Service Connector: 19366860  
 Description: 2-Way F 1.5 Series, Sealed( BK)

### Terminal Part Information

Terminal Type ID	Terminated Lead	Diagnostic Test Probe	Terminal Removal Tool
I	Not required	J-35616-14 (GN)	No Tool Required

### B5RR Rear Wheel Speed Sensor - Right

Pin	Size	Color	Circuit	Function	Terminal Type ID	Option
1	0.5	GY / YE	7128	Right Rear Wheel Speed Sensor Control	I	—
2	0.5	VT	882	Right Rear Wheel Speed Sensor Signal	I	—

**B10D Sun Load and Ambient Light and Security Indicator Sensor**

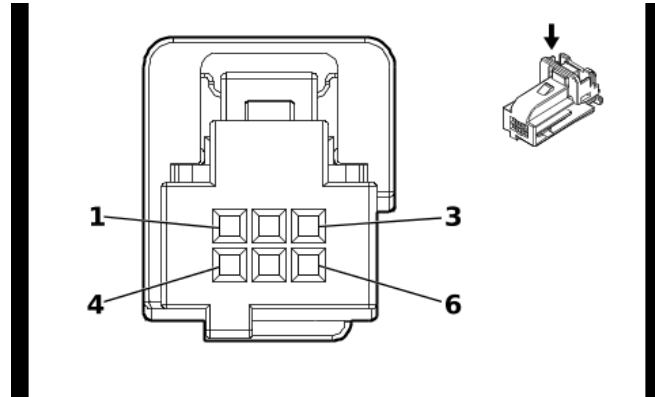

2282896

**Connector Part Information**

Harness Type: Instrument Panel Wiring Harness  
 OEM Connector: 2294663-1  
 Service Connector: 85587649  
 Description: 6-Way F 0.64 Micro-Quadlock Series( BK)

**Terminal Part Information**

Terminal Type ID	Terminated Lead	Diagnostic Test Probe	Terminal Removal Tool
I	Not required	J-35616-64B (L-BU)	No Tool Required

**B10D Sun Load and Ambient Light and Security Indicator Sensor**

Pin	Size	Color	Circuit	Function	Terminal Type ID	Option
1	0.35	GY	590	Driver Solar Sensor Signal	I	—
2	—	—	—	Not Occupied	—	—
3	0.35	WH / BU	278	Ambient Light Sensor Signal	I	—
4	0.35	BU / WH	734	Inside Air Temperature Sensor Signal	I	—
5	0.35	GY	728	Security Indicator Control	I	—
6	0.35	BK / YE	407	Sensor Low Reference	I	—

**B11LF Front Suspension 4 Corner Leveling System Position Sensor - Left (Z45)**

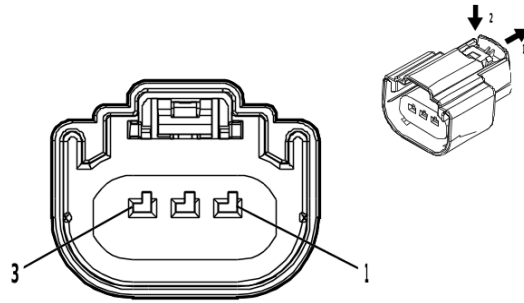

4569745

**Connector Part Information**

Harness Type: Chassis Wiring Harness  
 OEM Connector: 33343869  
 Service Connector: 19179750  
 Description: 3-Way F 1.5 MX Series, Sealed( BK)

**Terminal Part Information**

Terminal Type ID	Terminated Lead	Diagnostic Test Probe	Terminal Removal Tool
I	Not required	J-35616-14 (GN)	No Tool Required

**B11LF Front Suspension 4 Corner Leveling System Position Sensor - Left (Z45)**

Pin	Size	Color	Circuit	Function	Terminal Type ID	Option
1	0.5	BU / RD	1205	Left Front Suspension Position Sensor Voltage Reference	I	—
2	0.5	BK / BU	1206	Left Front Suspension Position Sensor Low Reference	I	—
3	0.5	BN / WH	1207	Left Front Suspension Position Sensor Signal	I	—

**B11LR Rear Suspension 2 or 4 Corner Air Leveling Position Sensor - Left (Z45)**

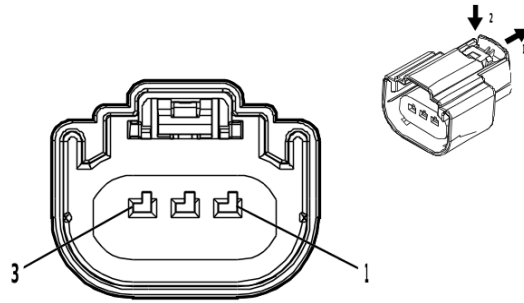

4569745

**Connector Part Information**

Harness Type: Chassis Wiring Harness  
 OEM Connector: 33343869  
 Service Connector: 19179750  
 Description: 3-Way F 1.5 MX Series, Sealed( BK)

**Terminal Part Information**

Terminal Type ID	Terminated Lead	Diagnostic Test Probe	Terminal Removal Tool
I	Not required	J-35616-14 (GN)	No Tool Required

**B11LR Rear Suspension 2 or 4 Corner Air Leveling Position Sensor - Left (Z45)**

Pin	Size	Color	Circuit	Function	Terminal Type ID	Option
1	0.5	YE / RD	1208	Left Rear Suspension Position Sensor Voltage Reference	I	—
2	0.5	BK / GN	1209	Left Rear Suspension Position Sensor Low Reference	I	—
3	0.5	GN / WH	1210	Left Rear Suspension Position Sensor Signal	I	—

**B13 Automatic Transmission Fluid Temperature Sensor (MHS / MQC)**

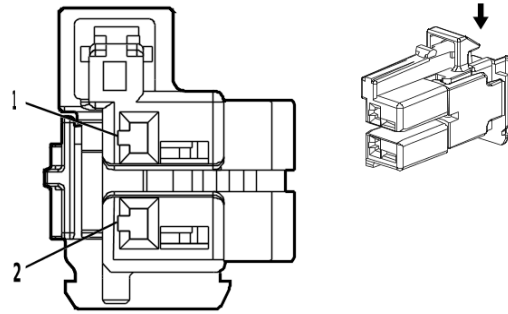

4672650

**Connector Part Information**

Harness Type: Automatic Transmission Wiring Harness - Control  
 OEM Connector: 2289523-1  
 Service Connector: Service by Harness - See Part Catalog  
 Description: 2-Way F 1.2 MCON Series( BN)

**Terminal Part Information**

Terminal Type ID	Terminated Lead	Diagnostic Test Probe	Terminal Removal Tool
I	Not required	J-35616-65B (L-BU)	No Tool Required

**B13 Automatic Transmission Fluid Temperature Sensor (MHS / MQC)**

Pin	Size	Color	Circuit	Function	Terminal Type ID	Option
1	0.5	BN / BN	586	Transmission Fluid Temperature Sensor Low Reference	I	—
2	0.5	BN / YE	585	Transmission Fluid Temperature Sensor Signal	I	—

**B13 Automatic Transmission Fluid Temperature Sensor (MHT / MI2 / MQB)**

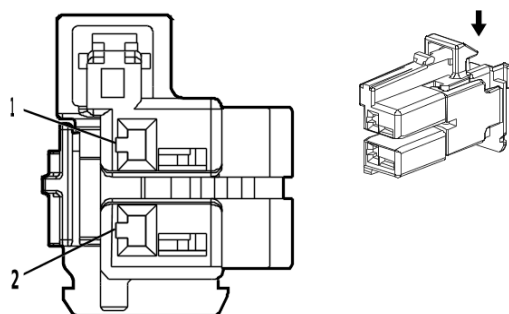

4672650

**Connector Part Information**

Harness Type: Automatic Transmission Wiring Harness - Control  
 OEM Connector: 2289523-1  
 Service Connector: Service by Harness - See Part Catalog  
 Description: 2-Way F 1.2 MCON Series( BN)

**Terminal Part Information**

Terminal Type ID	Terminated Lead	Diagnostic Test Probe	Terminal Removal Tool
I	Not required	J-35616-12 (BU)	No Tool Required

**B13 Automatic Transmission Fluid Temperature Sensor (MHT / MI2 / MQB)**

Pin	Size	Color	Circuit	Function	Terminal Type ID	Option
1	0.5	BK / BN	586	Transmission Fluid Temperature Sensor Low Reference	I	—
2	0.5	BK / BN	585	Transmission Fluid Temperature Sensor Signal	I	—



## B13 Automatic Transmission Fluid Temperature Sensor (MQE)

### Connector Part Information

Harness Type: Automatic Transmission Wiring Harness - Control  
 OEM Connector: 312004  
 Service Connector: Service by Harness - See Part Catalog  
 Description: —

### Terminal Part Information

Terminal Type ID	Terminated Lead	Diagnostic Test Probe	Terminal Removal Tool
I	Not required	J-35616-65B (L-BU)	No Tool Required

### B13 Automatic Transmission Fluid Temperature Sensor (MQE)

Pin	Size	Color	Circuit	Function	Terminal Type ID	Option
1	0.5	WH / GY	586	Transmission Fluid Temperature Sensor Low Reference	I	—
2	0.5	BK / GY	585	Transmission Fluid Temperature Sensor Signal	I	—

**B14A Automatic Transmission Output Speed Sensor (MHS / MQC)**

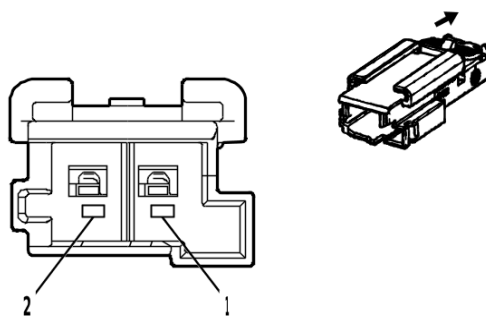

4672593

**Connector Part Information**

Harness Type: Automatic Transmission Wiring Harness - Case  
 OEM Connector: 2340311-2  
 Service Connector: Service by Harness - See Part Catalog  
 Description: 2-Way M SLV WIR CONN MALE

**Terminal Part Information**

Terminal Type ID	Terminated Lead	Diagnostic Test Probe	Terminal Removal Tool
I	Not required	J-35616-13 (BU)	No Tool Required

**B14A Automatic Transmission Output Speed Sensor (MHS / MQC)**

Pin	Size	Color	Circuit	Function	Terminal Type ID	Option
1	0.5	YE / OG	6358	Output Speed Signal	I	—
2	0.5	GN	4170	Transmission Output Shaft Speed Sensor Circuit 9V Reference	I	—

**B14A Automatic Transmission Output Speed Sensor (MHT / MI2 / MQB)**

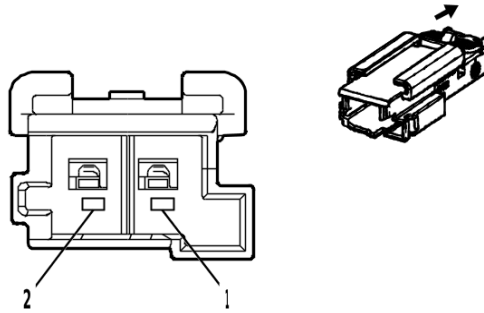

4672593

**Connector Part Information**

Harness Type: Automatic Transmission Wiring Harness - Case  
 OEM Connector: 2340311-2  
 Service Connector: Service by Harness - See Part Catalog  
 Description: 2-Way M SLV WIR CONN MALE

**Terminal Part Information**

Terminal Type ID	Terminated Lead	Diagnostic Test Probe	Terminal Removal Tool
I	Not required	J-35616-13 (BU)	No Tool Required

**B14A Automatic Transmission Output Speed Sensor (MHT / MI2 / MQB)**

Pin	Size	Color	Circuit	Function	Terminal Type ID	Option
1	0.5	YE / OG	6358	Output Speed Signal	I	—
2	0.5	GN	4170	Transmission Output Shaft Speed Sensor Circuit 9V Reference	I	—

**B14C Automatic Transmission Input Speed Sensor (MHS / MQC)**

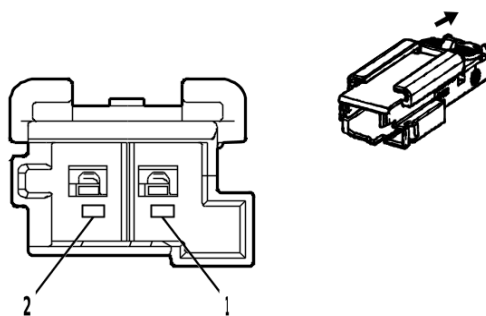

4672611

**Connector Part Information**

Harness Type: Automatic Transmission Wiring Harness - Case  
 OEM Connector: 2340311-3  
 Service Connector: Service by Harness - See Part Catalog  
 Description: 2-Way M SLV WIR CONN MALE

**Terminal Part Information**

Terminal Type ID	Terminated Lead	Diagnostic Test Probe	Terminal Removal Tool
I	Not required	J-35616-13 (BU)	No Tool Required

**B14C Automatic Transmission Input Speed Sensor (MHS / MQC)**

Pin	Size	Color	Circuit	Function	Terminal Type ID	Option
1	0.5	WH / VT	6353	Input Speed Signal	I	—
2	0.5	BU	4171	Transmission Input Shaft Speed Sensor Circuit 9V Reference	I	—

**B14C Automatic Transmission Input Speed Sensor (MHT / MQB)**

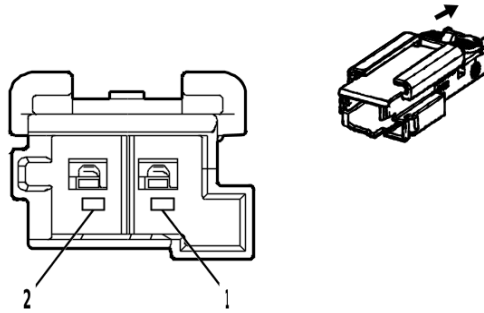

4672611

**Connector Part Information**

Harness Type: Automatic Transmission Wiring Harness - Case  
 OEM Connector: 2340311-3  
 Service Connector: Service by Harness - See Part Catalog  
 Description: 2-Way M SLV WIR CONN MALE

**Terminal Part Information**

Terminal Type ID	Terminated Lead	Diagnostic Test Probe	Terminal Removal Tool
I	Not required	J-35616-13 (BU)	No Tool Required

**B14C Automatic Transmission Input Speed Sensor (MHT / MQB)**

Pin	Size	Color	Circuit	Function	Terminal Type ID	Option
1	0.5	WH / VT	6353	Input Speed Signal	I	—
2	0.5	BU	4171	Transmission Input Shaft Speed Sensor Circuit 9V Reference	I	—

**B14DA Automatic Transmission Intermediate Speed Sensor 1 (MHS / MQC)**

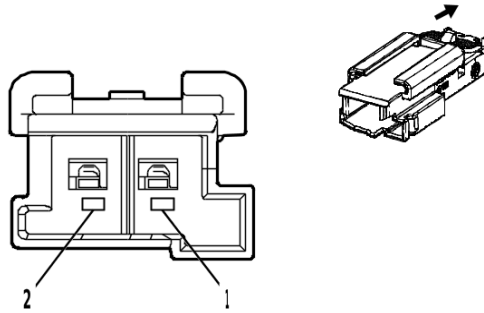

4663490

**Connector Part Information**

Harness Type: Automatic Transmission Wiring Harness - Case  
 OEM Connector: 2340311-1  
 Service Connector: Service by Harness - See Part Catalog  
 Description: 2-Way M SLV WIR CONN MALE

**Terminal Part Information**

Terminal Type ID	Terminated Lead	Diagnostic Test Probe	Terminal Removal Tool
I	Not required	J-35616-13 (BU)	No Tool Required

**B14DA Automatic Transmission Intermediate Speed Sensor 1 (MHS / MQC)**

Pin	Size	Color	Circuit	Function	Terminal Type ID	Option
1	0.5	VT / GN	4510	Transmission Intermediate Speed Signal	I	—
2	0.5	GN	4170	Transmission Output Shaft Speed Sensor Circuit 9V Reference	I	—

**B14DA Automatic Transmission Intermediate Speed Sensor 1 (MHT / MI2 / MQB)**

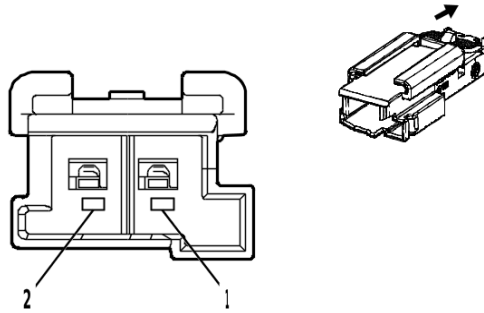

4663490

**Connector Part Information**

Harness Type: Automatic Transmission Wiring Harness - Case  
 OEM Connector: 2340311-1  
 Service Connector: Service by Harness - See Part Catalog  
 Description: 2-Way M SLV WIR CONN MALE

**Terminal Part Information**

Terminal Type ID	Terminated Lead	Diagnostic Test Probe	Terminal Removal Tool
I	Not required	J-35616-13 (BU)	No Tool Required

**B14DA Automatic Transmission Intermediate Speed Sensor 1 (MHT / MI2 / MQB)**

Pin	Size	Color	Circuit	Function	Terminal Type ID	Option
1	0.5	VT / GN	4510	Transmission Intermediate Speed Signal	I	—
2	0.5	GN	4170	Transmission Output Shaft Speed Sensor Circuit 9V Reference	I	—

**B14DB Automatic Transmission Intermediate Speed Sensor 2 (MHS / MQC)**

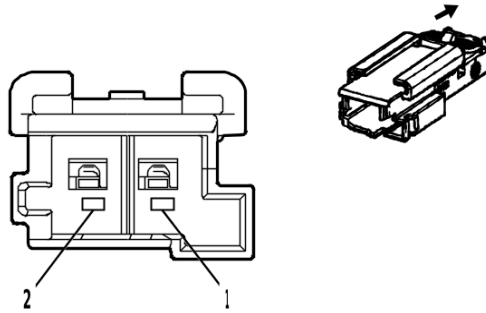

4672593

**Connector Part Information**

Harness Type: Automatic Transmission Wiring Harness - Case  
 OEM Connector: 2340311-2  
 Service Connector: Service by Harness - See Part Catalog  
 Description: 2-Way M SLV WIR CONN MALE

**Terminal Part Information**

Terminal Type ID	Terminated Lead	Diagnostic Test Probe	Terminal Removal Tool
I	Not required	J-35616-13 (BU)	No Tool Required

**B14DB Automatic Transmission Intermediate Speed Sensor 2 (MHS / MQC)**

Pin	Size	Color	Circuit	Function	Terminal Type ID	Option
1	0.5	WH / BU	6254	Transmission Input Speed Sensor Signal	I	—
2	0.5	BU	4171	Transmission Input Shaft Speed Sensor Circuit 9V Reference	I	—



**B14DB Automatic Transmission Intermediate Speed Sensor 2 (MHT / MI2 / MQB)**

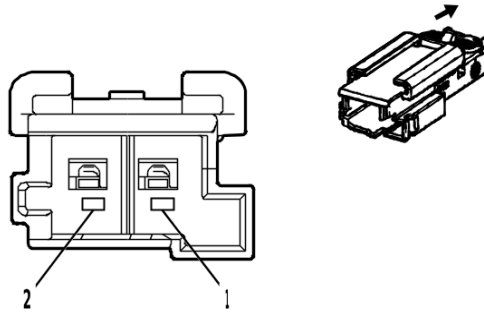

4672593

**Connector Part Information**

Harness Type: Automatic Transmission Wiring Harness - Case  
 OEM Connector: 2340311-2  
 Service Connector: Service by Harness - See Part Catalog  
 Description: 2-Way M SLV WIR CONN MALE

**Terminal Part Information**

Terminal Type ID	Terminated Lead	Diagnostic Test Probe	Terminal Removal Tool
I	Not required	J-35616-13 (BU)	No Tool Required

**B14DB Automatic Transmission Intermediate Speed Sensor 2 (MHT / MI2 / MQB)**

Pin	Size	Color	Circuit	Function	Terminal Type ID	Option
1	0.5	WH / BU	6254	Transmission Input Speed Sensor Signal	I	—
2	0.5	BU	4171	Transmission Input Shaft Speed Sensor Circuit 9V Reference	I	—

**B20A Brake Fluid Level Indicator Switch**

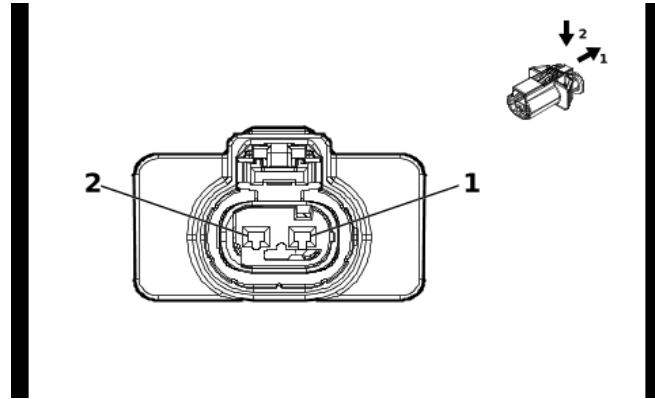

5877143

**Connector Part Information**

Harness Type: Body Wiring Harness  
 OEM Connector: 35242147  
 Service Connector: 85596543  
 Description: 2-Way F 1.2 MLK Series, Sealed( BK)

**Terminal Part Information**

Terminal Type ID	Terminated Lead	Diagnostic Test Probe	Terminal Removal Tool
I	Not required	J-35616-16 (L-GN)	No Tool Required

**B20A Brake Fluid Level Indicator Switch**

Pin	Size	Color	Circuit	Function	Terminal Type ID	Option
1	0.5	GN / GY	333	Brake Fluid Level Signal	I	—
2	0.5	BK / WH	151	Signal Ground	I	—

## B22 Brake Pedal Position Sensor

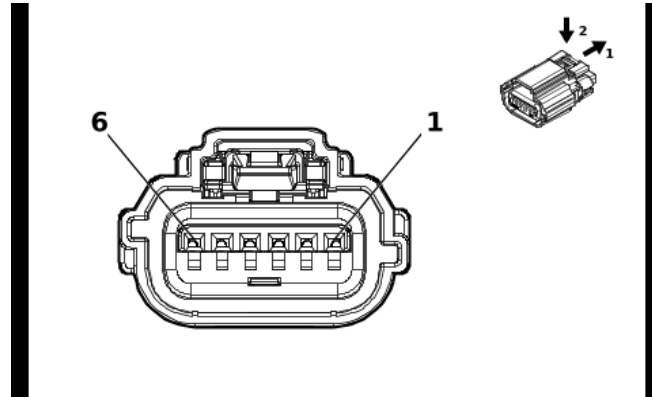

5921818

### Connector Part Information

Harness Type: Body Wiring Harness  
 OEM Connector: 35547326  
 Service Connector: 86825468  
 Description: 6-Way F 0.64 OCS Series, Sealed( NA)

### Terminal Part Information

Terminal Type ID	Terminated Lead	Diagnostic Test Probe	Terminal Removal Tool
I	Not required	J-35616-64B (L-BU)	No Tool Required

### B22 Brake Pedal Position Sensor

Pin	Size	Color	Circuit	Function	Terminal Type ID	Option
1	0.35	BK / BN	5360	Brake Apply Sensor Low Reference	I	—
2	0.35	WH	5359	Brake Apply Sensor Control	I	—
3	0.35	BU / YE	5361	Brake Apply Sensor Signal	I	—
4	0.35	WH / GN	5380	Brake Position Sensor Signal	I	—
5	0.35	BK / GY	626	Engine Control Vehicle Sensors Low Reference 1	I	—
6	0.35	WH / RD	480	Engine Control Vehicle Sensors 5 Volt Reference 1	I	—

**B23 Camshaft Position Sensor (L3B)**

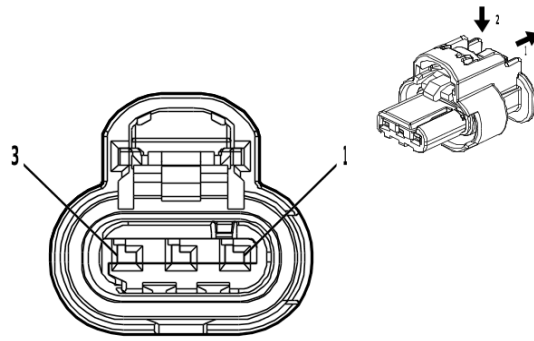

4581126

**Connector Part Information**

Harness Type: Engine Wiring Harness  
 OEM Connector: 1-2296695-1  
 Service Connector: 86792094  
 Description: 3-Way F 1.2 MCON-CB Series, Sealed( BK)

**Terminal Part Information**

Terminal Type ID	Terminated Lead	Diagnostic Test Probe	Terminal Removal Tool
I	Not required	J-35616-16 (L-GN)	No Tool Required

**B23 Camshaft Position Sensor (L3B)**

Pin	Size	Color	Circuit	Function	Terminal Type ID	Option
1	0.5	GY / BU	5300	Intake Camshaft Position Sensor 1 Voltage Reference	I	L84 / L87
	0.5	GY / YE	5297	Exhaust Camshaft Position Sensor 1 Voltage Reference	I	LZ0
2	0.5	BK / GN	5301	Intake Camshaft Position Sensor Low Reference 1	I	L84 / L87
	0.5	BK / GY	5296	Exhaust Camshaft Position Sensor Low Reference 1	I	LZ0
3	0.5	YE / VT	5275	Intake Camshaft Position Sensor 1	I	L84 / L87
	0.5	VT / BK	5273	Exhaust Camshaft Position Sensor 1	I	LZ0

**B23 Camshaft Position Sensor (L84 / L87)**

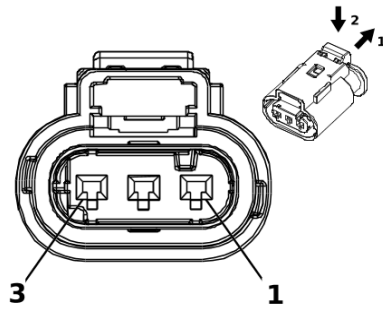

2717069

**Connector Part Information**

Harness Type: Camshaft Position Sensor Wire  
 OEM Connector: 13503570  
 Service Connector: Service by Harness - See Part Catalog  
 Description: 3-Way F 1.2 Multilock Series, Sealed( BK)

**Terminal Part Information**

Terminal Type ID	Terminated Lead	Diagnostic Test Probe	Terminal Removal Tool
I	Not required	J-35616-12 (BU)	No Tool Required

**B23 Camshaft Position Sensor (L84 / L87)**

Pin	Size	Color	Circuit	Function	Terminal Type ID	Option
1	0.5	GY / BU	5300	Intake Camshaft Position Sensor 1 Voltage Reference	I	—
2	0.5	BK / GN	5301	Intake Camshaft Position Sensor Low Reference 1	I	—
3	0.5	YE / VT	5275	Intake Camshaft Position Sensor 1	I	—

**B24LF Mobile Telephone Microphone - Left Front**

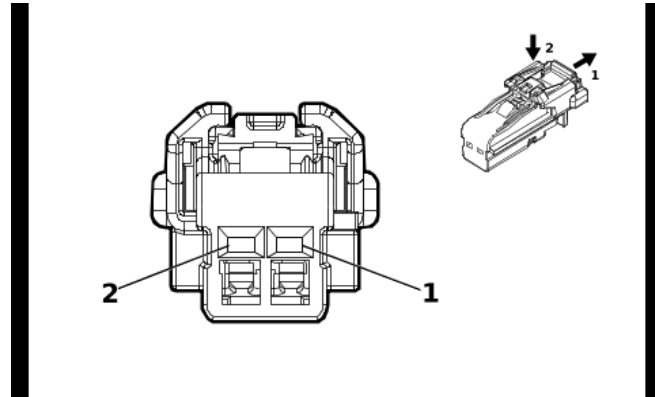

4115691

**Connector Part Information**

Harness Type: Dome Lamp Wiring Harness  
 OEM Connector: 6098-8988  
 Service Connector: 87816612  
 Description: 2-Way F 1.2 MCON Series( BK)

**Terminal Part Information**

Terminal Type ID	Terminated Lead	Diagnostic Test Probe	Terminal Removal Tool
I	Not required	J-35616-12 (BU)	No Tool Required

**B24LF Mobile Telephone Microphone - Left Front**

Pin	Size	Color	Circuit	Function	Terminal Type ID	Option
1	0.35	BK / BN	654	Cellular Telephone Microphone Low Reference	I	—
2	0.35	BU	655	Cellular Telephone Microphone Signal	I	—

**B24RF Mobile Telephone Microphone - Right Front**

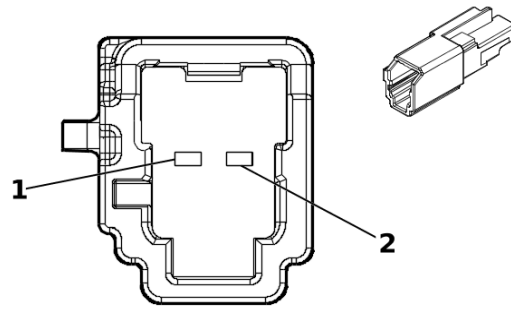

5360948

**Connector Part Information**

Harness Type: Dome Lamp Wiring Harness  
 OEM Connector: 6098-9073  
 Service Connector: 84847259  
 Description: 2-Way M 1.2 MCON Series( GY)

**Terminal Part Information**

Terminal Type ID	Terminated Lead	Diagnostic Test Probe	Terminal Removal Tool
I	Not required	J-35616-13 (BU)	No Tool Required

**B24RF Mobile Telephone Microphone - Right Front**

Pin	Size	Color	Circuit	Function	Terminal Type ID	Option
1	0.35	BU / BK	7044	Microphone [-] Signal	I	—
2	0.35	VT / YE	7043	Microphone [+] Signal	I	—

**B26 Crankshaft Position Sensor (L3B)**

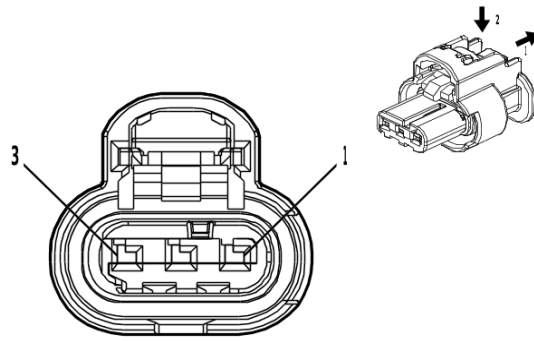

4778903

**Connector Part Information**

Harness Type: Engine Wiring Harness  
 OEM Connector: 1-2296695-2  
 Service Connector: 86792095  
 Description: 3-Way F 1.2 MCON-CB Series, Sealed( BK)

**Terminal Part Information**

Terminal Type ID	Terminated Lead	Diagnostic Test Probe	Terminal Removal Tool
I	Not required	J-35616-16 (L-GN)	No Tool Required

**B26 Crankshaft Position Sensor (L3B)**

Pin	Size	Color	Circuit	Function	Terminal Type ID	Option
1	0.5	VT / BU	6270	Crankshaft Position Sensor Voltage	I	—
2	0.5	BK / VT	6272	Crankshaft Position Sensor Low Reference	I	—
3	0.5	GN	6271	Crankshaft Position Sensor Signal	I	—



**B26 Crankshaft Position Sensor (L84 / L87)**

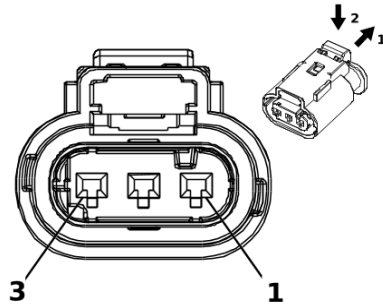

2717069

**Connector Part Information**

Harness Type: Engine Wiring Harness  
 OEM Connector: 10010341  
 Service Connector: 84601390  
 Description: 3-Way F 1.2 Multilock Series, Sealed( BK)

**Terminal Part Information**

Terminal Type ID	Terminated Lead	Diagnostic Test Probe	Terminal Removal Tool
I	Not required	J-35616-16 (L-GN)	No Tool Required

**B26 Crankshaft Position Sensor (L84 / L87)**

Pin	Size	Color	Circuit	Function	Terminal Type ID	Option
1	0.5	GN	6271	Crankshaft Position Sensor Signal	I	—
2	0.5	BK / VT	6272	Crankshaft Position Sensor Low Reference	I	—
3	0.5	VT / BU	6270	Crankshaft Position Sensor Voltage	I	—

**B26 Crankshaft Position Sensor (LZ0)**

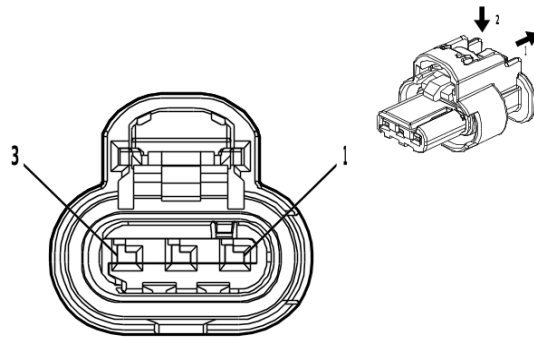

4581126

**Connector Part Information**

Harness Type: Engine Wiring Harness  
 OEM Connector: 1-2296695-1  
 Service Connector: 86792094  
 Description: 3-Way F 1.2 MCON-CB Series, Sealed( BK)

**Terminal Part Information**

Terminal Type ID	Terminated Lead	Diagnostic Test Probe	Terminal Removal Tool
I	Not required	J-35616-16 (L-GN)	No Tool Required

**B26 Crankshaft Position Sensor (LZ0)**

Pin	Size	Color	Circuit	Function	Terminal Type ID	Option
1	0.5	VT / BU	6270	Crankshaft Position Sensor Voltage	I	—
2	0.5	BK / VT	6272	Crankshaft Position Sensor Low Reference	I	—
3	0.5	GN	6271	Crankshaft Position Sensor Signal	I	—

**B34 Engine Coolant Temperature Sensor (L84 / L87)**

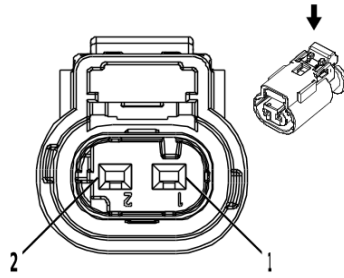

2717066

**Connector Part Information**

Harness Type: Valve Rocker Arm Oil Control Valve Extension Harness  
 OEM Connector: 10010337  
 Service Connector: Service by Harness - See Part Catalog  
 Description: 2-Way F 1.2 Multilock Series, Sealed( BK)

**Terminal Part Information**

Terminal Type ID	Terminated Lead	Diagnostic Test Probe	Terminal Removal Tool
I	Not required	J-35616-12 (BU)	No Tool Required

**B34 Engine Coolant Temperature Sensor (L84 / L87)**

Pin	Size	Color	Circuit	Function	Terminal Type ID	Option
1	0.5	BU	410	Engine Coolant Temperature Sensor Signal	I	—
2	0.5	BK / YE	626	Engine Control Vehicle Sensors Low Reference 1	I	—

**B34 Engine Coolant Temperature Sensor (LZ0)**

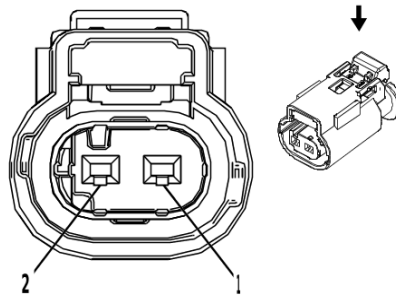

2830969

**Connector Part Information**

Harness Type: Engine Wiring Harness  
 OEM Connector: 10010339  
 Service Connector: 13587321  
 Description: 2-Way F 1.2 Multilock Series, Sealed( D-GY)

**Terminal Part Information**

Terminal Type ID	Terminated Lead	Diagnostic Test Probe	Terminal Removal Tool
I	Not required	J-35616-16 (L-GN)	No Tool Required

**B34 Engine Coolant Temperature Sensor (LZ0)**

Pin	Size	Color	Circuit	Function	Terminal Type ID	Option
1	0.5	YE / BU	2408	Engine Inlet Coolant Temperature Signal	I	—
2	0.5	BK / YE	548	Engine Control Sensors Low Reference 1	I	—

## B34A Engine Coolant Temperature Sensor 1

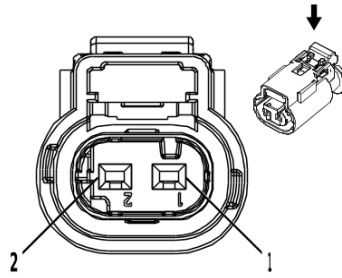

2717066

### Connector Part Information

Harness Type: Engine Wiring Harness  
 OEM Connector: 10010337  
 Service Connector: 13587326  
 Description: 2-Way F 1.2 Multilock Series, Sealed( BK)

### Terminal Part Information

Terminal Type ID	Terminated Lead	Diagnostic Test Probe	Terminal Removal Tool
I	Not required	J-35616-16 (L-GN)	No Tool Required

### B34A Engine Coolant Temperature Sensor 1

Pin	Size	Color	Circuit	Function	Terminal Type ID	Option
1	0.5	YE / BU	2408	Engine Inlet Coolant Temperature Signal	I	—
2	0.5	BK / YE	548	Engine Control Sensors Low Reference 1	I	—

**B34B Engine Coolant Temperature Sensor 2 (L3B)**

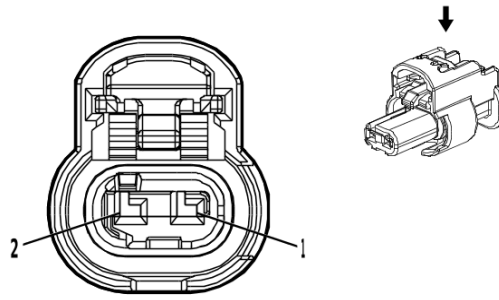

4690744

**Connector Part Information**

Harness Type: Engine Wiring Harness  
 OEM Connector: 1-2296694-3  
 Service Connector: 19366871  
 Description: 2-Way F 1.2 MCON Series, Sealed( BK)

**Terminal Part Information**

Terminal Type ID	Terminated Lead	Diagnostic Test Probe	Terminal Removal Tool
I	Not required	J-35616-16 (L-GN)	No Tool Required

**B34B Engine Coolant Temperature Sensor 2 (L3B)**

Pin	Size	Color	Circuit	Function	Terminal Type ID	Option
1	0.5	VT	2988	Engine Outlet Coolant Temperature Signal	I	—
2	0.5	BK / GY	626	Engine Control Vehicle Sensors Low Reference 1	I	—

**B34B Engine Coolant Temperature Sensor 2 (LZ0)**

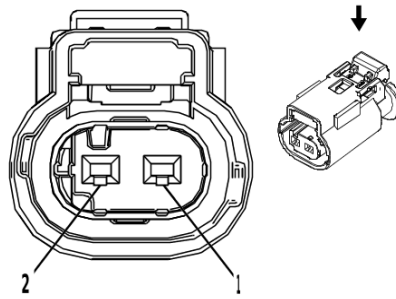

2830969

**Connector Part Information**

Harness Type: Engine Coolant Temperature Sensor Harness  
 OEM Connector: 13503568  
 Service Connector: Service by Harness - See Part Catalog  
 Description: 2-Way F 1.2 Multilock Series, Sealed( D-GY)

**Terminal Part Information**

Terminal Type ID	Terminated Lead	Diagnostic Test Probe	Terminal Removal Tool
I	Not required	J-35616-12 (BU)	No Tool Required

**B34B Engine Coolant Temperature Sensor 2 (LZ0)**

Pin	Size	Color	Circuit	Function	Terminal Type ID	Option
1	0.5	VT	2988	Engine Outlet Coolant Temperature Signal	I	—
2	0.5	BK / GY	626	Engine Control Vehicle Sensors Low Reference 1	I	—

**B34E Engine Coolant Temperature Sensor 5**

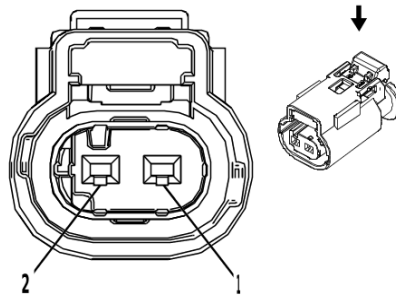

2830969

**Connector Part Information**

Harness Type: Engine Wiring Harness  
 OEM Connector: 10010339  
 Service Connector: 13587321  
 Description: 2-Way F 1.2 Multilock Series, Sealed( D-GY)

**Terminal Part Information**

Terminal Type ID	Terminated Lead	Diagnostic Test Probe	Terminal Removal Tool
I	Not required	J-35616-16 (L-GN)	No Tool Required

**B34E Engine Coolant Temperature Sensor 5**

Pin	Size	Color	Circuit	Function	Terminal Type ID	Option
1	0.5	BU / YE	8938	Engine Integrated Exhaust Manifold Temperature Signal	I	—
2	0.5	BK / YE	548	Engine Control Sensors Low Reference 1	I	—



## B34F Engine Coolant Temperature Sensor 6

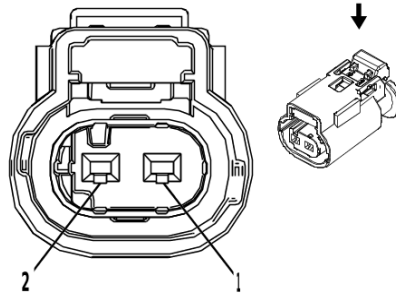

2830969

### Connector Part Information

Harness Type: Engine Wiring Harness  
 OEM Connector: 10010339  
 Service Connector: 13587321  
 Description: 2-Way F 1.2 Multilock Series, Sealed( D-GY)

### Terminal Part Information

Terminal Type ID	Terminated Lead	Diagnostic Test Probe	Terminal Removal Tool
I	Not required	J-35616-16 (L-GN)	No Tool Required

### B34F Engine Coolant Temperature Sensor 6

Pin	Size	Color	Circuit	Function	Terminal Type ID	Option
1	0.5	GY / VT	2404	Engine Block Coolant Temperature Signal	I	—
2	0.5	BK / YE	548	Engine Control Sensors Low Reference 1	I	—

**B34K Charge Air Cooler Coolant Temperature Sensor - Inlet**

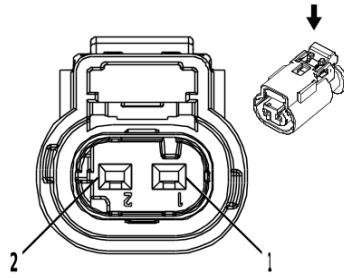

2717066

**Connector Part Information**

Harness Type: Engine Wiring Harness  
 OEM Connector: 10010337  
 Service Connector: 13587326  
 Description: 2-Way F 1.2 Multilock Series, Sealed( BK)

**Terminal Part Information**

Terminal Type ID	Terminated Lead	Diagnostic Test Probe	Terminal Removal Tool
I	Not required	J-35616-16 (L-GN)	No Tool Required

**B34K Charge Air Cooler Coolant Temperature Sensor - Inlet**

Pin	Size	Color	Circuit	Function	Terminal Type ID	Option
1	0.5	BU / BK	1422	Engine Water Charge Air Coolant Temperature Signal	I	—
2	0.5	BK / GY	626	Engine Control Vehicle Sensors Low Reference 1	I	—

## B35 Engine Oil Level Indicator Switch

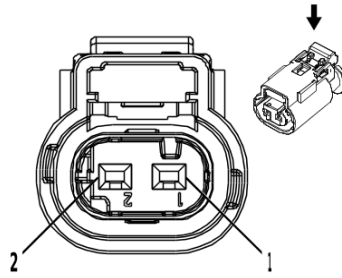

2717066

### Connector Part Information

Harness Type: Engine Wiring Harness  
 OEM Connector: 10010337  
 Service Connector: 13587326  
 Description: 2-Way F 1.2 Multilock Series, Sealed( BK)

### Terminal Part Information

Terminal Type ID	Terminated Lead	Diagnostic Test Probe	Terminal Removal Tool
I	Not required	J-35616-16 (L-GN)	No Tool Required

### B35 Engine Oil Level Indicator Switch

Pin	Size	Color	Circuit	Function	Terminal Type ID	Option
1	0.5	BN / GN	1174	Oil Level Switch Signal	I	—
2	0.75	BK / WH	251	Signal Ground	I	—

**B36 Engine Oil Temperature Sensor**

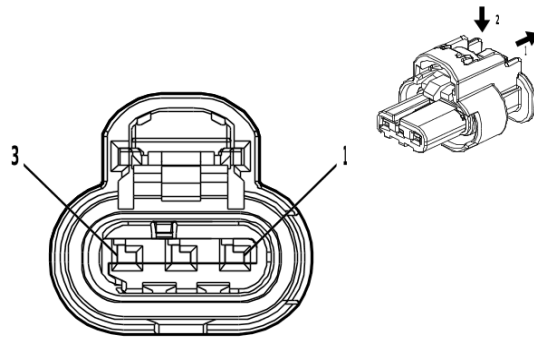

4994602

**Connector Part Information**

Harness Type: Engine Wiring Harness  
 OEM Connector: 1-2296695-3  
 Service Connector: 19371199  
 Description: 3-Way F 1.2 MCON-CB Series, Sealed( BK)

**Terminal Part Information**

Terminal Type ID	Terminated Lead	Diagnostic Test Probe	Terminal Removal Tool
I	Not required	J-35616-16 (L-GN)	No Tool Required

**B36 Engine Oil Temperature Sensor**

Pin	Size	Color	Circuit	Function	Terminal Type ID	Option
1	0.5	BK / YE	548	Engine Control Sensors Low Reference 1	I	L3B
	0.5	BK / GY	626	Engine Control Vehicle Sensors Low Reference 1	I	LZ0
2	0.5	BN / BU	357	Oil Temperature Sensor Signal	I	—
3	0.5	VT	7485	Engine Oil Temperature Sensor 2 Signal	I	—

**B37B Engine Oil Pressure Sensor (L3B)**

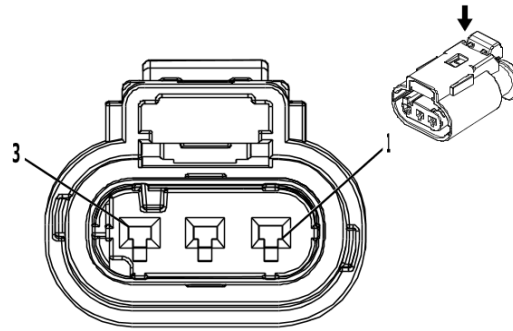

3240107

**Connector Part Information**

Harness Type: Engine Wiring Harness  
 OEM Connector: 10010344  
 Service Connector: 19301717  
 Description: 3-Way F 1.2 Multilock Series, Sealed( BK)

**Terminal Part Information**

Terminal Type ID	Terminated Lead	Diagnostic Test Probe	Terminal Removal Tool
I	Not required	J-35616-16 (L-GN)	No Tool Required

**B37B Engine Oil Pressure Sensor (L3B)**

Pin	Size	Color	Circuit	Function	Terminal Type ID	Option
1	0.5	YE / BN	331	Oil Pressure Sensor Signal	I	—
2	0.5	BK / YE	548	Engine Control Sensors Low Reference 1	I	—
3	0.5	BU / RD	460	Engine Control Sensors 5 Volt Reference 1	I	—

**B37B Engine Oil Pressure Sensor (L84 / L87)**

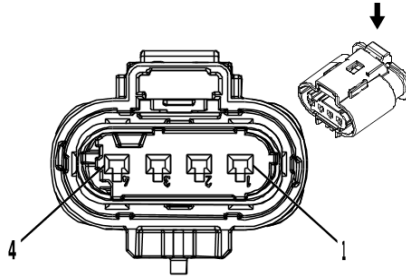

2717079

**Connector Part Information**

Harness Type: Engine Wiring Harness  
 OEM Connector: 10010346  
 Service Connector: 13587299  
 Description: 4-Way F 1.2 Multilock Series, Sealed( BK)

**Terminal Part Information**

Terminal Type ID	Terminated Lead	Diagnostic Test Probe	Terminal Removal Tool
I	Not required	J-35616-16 (L-GN)	No Tool Required

**B37B Engine Oil Pressure Sensor (L84 / L87)**

Pin	Size	Color	Circuit	Function	Terminal Type ID	Option
1	0.5	BK / GN	580	Engine Control Sensors Low Reference 2	I	—
2	0.5	YE / BN	331	Oil Pressure Sensor Signal	I	—
3	0.5	BU / RD	460	Engine Control Sensors 5 Volt Reference 1	I	—
4	0.5	BN / BU	357	Oil Temperature Sensor Signal	I	—

## B37B Engine Oil Pressure Sensor (LZ0)

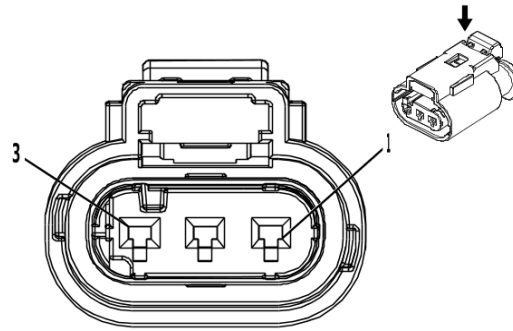

3240107

### Connector Part Information

Harness Type: Engine Wiring Harness  
 OEM Connector: 10010344  
 Service Connector: 19301717  
 Description: 3-Way F 1.2 Multilock Series, Sealed( BK)

### Terminal Part Information

Terminal Type ID	Terminated Lead	Diagnostic Test Probe	Terminal Removal Tool
I	Not required	J-35616-16 (L-GN)	No Tool Required

### B37B Engine Oil Pressure Sensor (LZ0)

Pin	Size	Color	Circuit	Function	Terminal Type ID	Option
1	0.5	YE / BN	331	Oil Pressure Sensor Signal	I	—
2	0.5	BK / YE	548	Engine Control Sensors Low Reference 1	I	—
3	0.5	BU / RD	460	Engine Control Sensors 5 Volt Reference 1	I	—

**B39 Air Conditioning Evaporator Air Temperature Sensor**

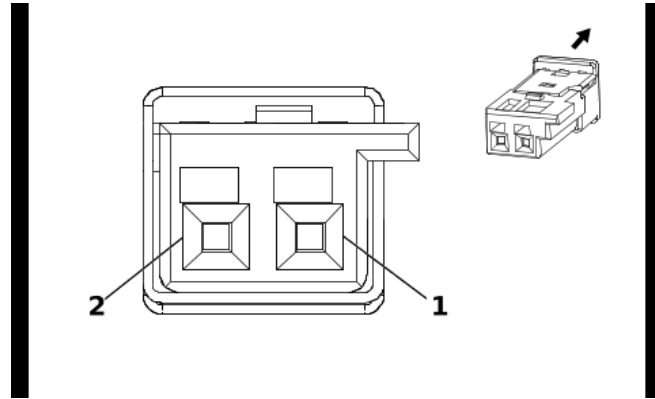

2780265

**Connector Part Information**

Harness Type: Heater Wiring Harness  
 OEM Connector: 13535799  
 Service Connector: Service by Harness - See Part Catalog  
 Description: 2-Way F 0.64 Micro-Quadlock Series( NA)

**Terminal Part Information**

Terminal Type ID	Terminated Lead	Diagnostic Test Probe	Terminal Removal Tool
I	Not required	J-35616-64B (L-BU)	No Tool Required

**B39 Air Conditioning Evaporator Air Temperature Sensor**

Pin	Size	Color	Circuit	Function	Terminal Type ID	Option
1	0.35	BN	6137	Air Conditioning Evaporator Temperature Sensor Signal	I	—
2	0.35	BK / YE	407	Sensor Low Reference	I	—



## B47 Fuel Pressure Sensor

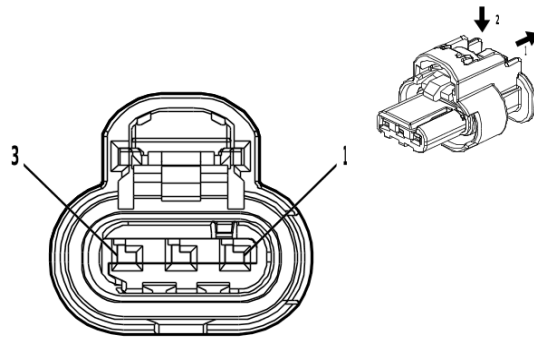

4581126

### Connector Part Information

Harness Type: Chassis Wiring Harness  
 OEM Connector: 1-2296695-1  
 Service Connector: 86792094  
 Description: 3-Way F 1.2 MCON-CB Series, Sealed( BK)

### Terminal Part Information

Terminal Type ID	Terminated Lead	Diagnostic Test Probe	Terminal Removal Tool
I	Not required	J-35616-12 (BU)	No Tool Required

### B47 Fuel Pressure Sensor

Pin	Size	Color	Circuit	Function	Terminal Type ID	Option
1	0.5	BN / RD	7445	Fuel Line Pressure Sensor 5V Reference	I	—
2	0.5	BK / YE	7447	Fuel Pressure Sensor Low Reference	I	—
3	0.5	BU / WH	7446	Fuel Pressure Sensor Signal	I	—

**B47B Fuel Rail Pressure Sensor (L3B)**

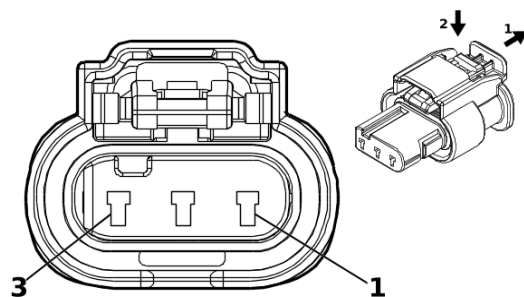

5420917

**Connector Part Information**

Harness Type: Fuel Injector Wiring Harness  
 OEM Connector: 34900-3127  
 Service Connector: Service by Harness - See Part Catalog  
 Description: 3-Way F 1.2 MCON-LL Series, Sealed( GY)

**Terminal Part Information**

Terminal Type ID	Terminated Lead	Diagnostic Test Probe	Terminal Removal Tool
I	Not required	J-35616-12 (BU)	No Tool Required

**B47B Fuel Rail Pressure Sensor (L3B)**

Pin	Size	Color	Circuit	Function	Terminal Type ID	Option
1	0.5	BK / GN	580	Engine Control Sensors Low Reference 2	I	—
2	0.5	BU / WH	10786	Fuel Rail Pressure Sensor SENT 1 Signal	I	—
3	0.5	WH / RD	480	Engine Control Vehicle Sensors 5 Volt Reference 1	I	—

**B47B Fuel Rail Pressure Sensor (L84 / L87)**

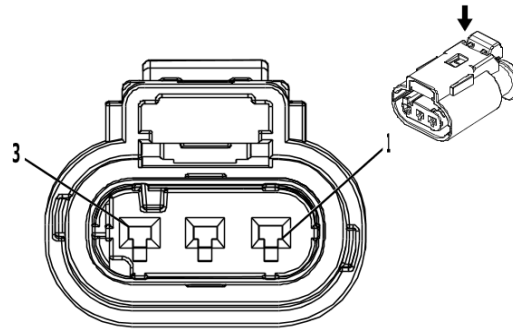

3240107

**Connector Part Information**

Harness Type: Fuel Injector Wiring Harness - Bank 1  
 OEM Connector: 172007659  
 Service Connector: Service by Harness - See Part Catalog  
 Description: 3-Way F 1.2 Multilock Series, Sealed( BK)

**Terminal Part Information**

Terminal Type ID	Terminated Lead	Diagnostic Test Probe	Terminal Removal Tool
I	Not required	J-35616-16 (L-GN)	No Tool Required

**B47B Fuel Rail Pressure Sensor (L84 / L87)**

Pin	Size	Color	Circuit	Function	Terminal Type ID	Option
1	0.5	BK / GN	548	Engine Control Sensors Low Reference 1	I	—
2	0.5	BU / WH	10786	Fuel Rail Pressure Sensor SENT 1 Signal	I	—
3	0.5	BN / RD	480	Engine Control Vehicle Sensors 5 Volt Reference 1	I	—

**B47B Fuel Rail Pressure Sensor (LZ0)**

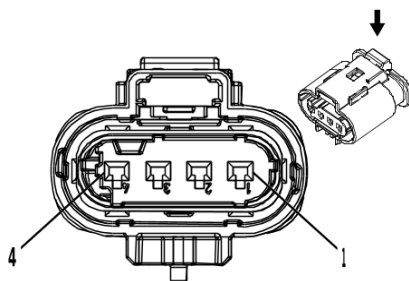

2717079

**Connector Part Information**

Harness Type: Engine Wiring Harness  
 OEM Connector: 10010346  
 Service Connector: 13587299  
 Description: 4-Way F 1.2 Multilock Series, Sealed( BK)

**Terminal Part Information**

Terminal Type ID	Terminated Lead	Diagnostic Test Probe	Terminal Removal Tool
I	Not required	J-35616-16 (L-GN)	No Tool Required

**B47B Fuel Rail Pressure Sensor (LZ0)**

Pin	Size	Color	Circuit	Function	Terminal Type ID	Option
1	0.5	BN / RD	2917	Fuel Rail Pressure Sensor 5V Reference	I	—
2	0.5	BN / YE	2161	Fuel Rail Pressure Sensor 2 Signal	I	—
3	0.5	BK / GN	2919	Fuel Rail Pressure Sensor Low Reference	I	—
4	0.5	BU / WH	2918	Fuel Rail Pressure Sensor Signal	I	—

## B52A Heated Oxygen Sensor 1

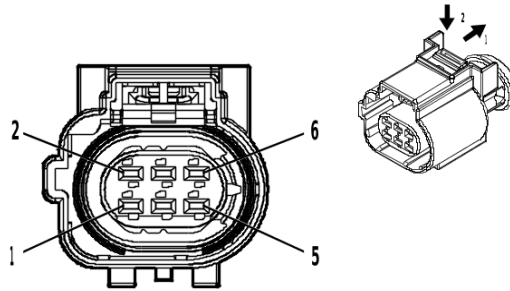

5086832

### Connector Part Information

Harness Type: Engine Wiring Harness  
 OEM Connector: 2-2309220-8  
 Service Connector: 84613131  
 Description: 6-Way F 1.5 MCP Series, Sealed( GY)

### Terminal Part Information

Terminal Type ID	Terminated Lead	Diagnostic Test Probe	Terminal Removal Tool
I	Not required	J-35616-14 (GN)	No Tool Required

### B52A Heated Oxygen Sensor 1

Pin	Size	Color	Circuit	Function	Terminal Type ID	Option
1	0.5	BN / WH	6933	HO2S Pump Current Signal	I	—
2	0.5	BN	6934	HO2S Ground	I	—
3	0.5	GY / WH	3113	HO2S Heater Low Control Bank 1 Sensor 1	I	—
4	0.5	VT / BU	5293	Powertrain Main Relay Fused Supply Voltage 4	I	—
5	0.5	GN	6935	HO2S Pump Current Trim Signal	I	—
6	0.5	YE / GY	6936	HO2S Signal	I	—

**B52B Heated Oxygen Sensor 2**

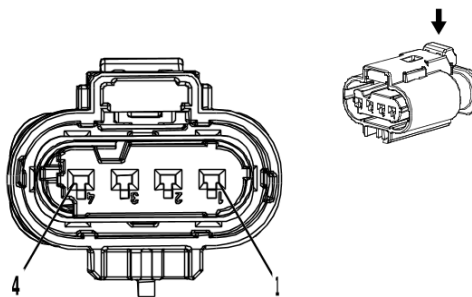

4036496

**Connector Part Information**

Harness Type: Engine Wiring Harness  
 OEM Connector: 10021265  
 Service Connector: 19330904  
 Description: 4-Way F 1.2 Multilock Series, Sealed( BK)

**Terminal Part Information**

Terminal Type ID	Terminated Lead	Diagnostic Test Probe	Terminal Removal Tool
I	Not required	J-35616-16 (L-GN)	No Tool Required

**B52B Heated Oxygen Sensor 2**

Pin	Size	Color	Circuit	Function	Terminal Type ID	Option
1	0.5	GY / WH	3122	HO2S Heater Low Control Bank 1 Sensor 2	I	—
2	0.5	VT / BU	5294	Powertrain Main Relay Fused Supply Voltage 5	I	—
3	0.5	WH / YE	3121	HO2S Low Signal Bank 1 Sensor 2	I	—
4	0.5	VT / BU	3120	HO2S High Signal Bank 1 Sensor 2	I	—

**B52C Heated Oxygen Sensor - Bank 1 Sensor 1 ((L84 / L87) & FJW)**

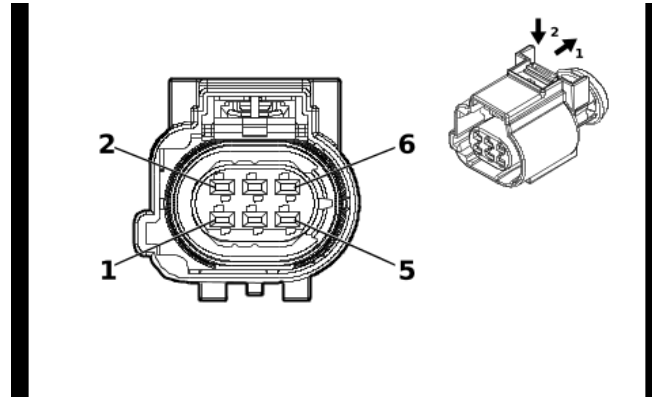

6312186

**Connector Part Information**

Harness Type: Engine Wiring Harness  
 OEM Connector: 13550230  
 Service Connector: Service by Harness - See Part Catalog  
 Description: 6-Way F 1.5 MCP Series, Sealed( BN)

**Terminal Part Information**

Terminal Type ID	Terminated Lead	Diagnostic Test Probe	Terminal Removal Tool
I	Not required	J-35616-14 (GN)	No Tool Required

**B52C Heated Oxygen Sensor - Bank 1 Sensor 1 ((L84 / L87) & FJW)**

Pin	Size	Color	Circuit	Function	Terminal Type ID	Option
1	0.5	BN / WH	6933	HO2S Pump Current Signal	I	—
2	0.5	BN	6934	HO2S Ground	I	—
3	0.5	GY / WH	3113	HO2S Heater Low Control Bank 1 Sensor 1	I	—
4	0.5	VT / BU	5293	Powertrain Main Relay Fused Supply Voltage 4	I	—
5	0.5	GN	6935	HO2S Pump Current Trim Signal	I	—
6	0.5	YE / GY	6936	HO2S Signal	I	—

**B52C Heated Oxygen Sensor - Bank 1 Sensor 1 (L84 & (FHR / FHS))**

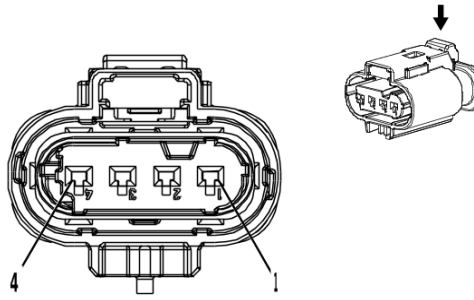

4381050

**Connector Part Information**

Harness Type: Engine Wiring Harness  
 OEM Connector: 10021267  
 Service Connector: 19354075  
 Description: 4-Way F 1.2 Multilock Series, Sealed( GY)

**Terminal Part Information**

Terminal Type ID	Terminated Lead	Diagnostic Test Probe	Terminal Removal Tool
I	Not required	J-35616-16 (L-GN)	No Tool Required

**B52C Heated Oxygen Sensor - Bank 1 Sensor 1 (L84 & (FHR / FHS))**

Pin	Size	Color	Circuit	Function	Terminal Type ID	Option
1	0.5	GY / WH	3113	HO2S Heater Low Control Bank 1 Sensor 1	I	—
2	0.5	VT / BU	5293	Powertrain Main Relay Fused Supply Voltage 4	I	—
3	0.5	WH / BK	3111	HO2S Low Signal Bank 1 Sensor 1	I	—
4	0.5	VT / GY	3110	HO2S High Signal Bank 1 Sensor 1	I	—



**B52D Heated Oxygen Sensor - Bank 1 Sensor 2**

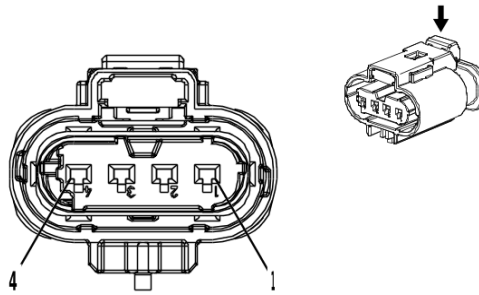

4036370

**Connector Part Information**

Harness Type: Engine Wiring Harness  
 OEM Connector: 10021266  
 Service Connector: 19330920  
 Description: 4-Way F 1.2 Multilock Series, Sealed( GY)

**Terminal Part Information**

Terminal Type ID	Terminated Lead	Diagnostic Test Probe	Terminal Removal Tool
I	Not required	J-35616-16 (L-GN)	No Tool Required

**B52D Heated Oxygen Sensor - Bank 1 Sensor 2**

Pin	Size	Color	Circuit	Function	Terminal Type ID	Option
1	0.5	GY / WH	3122	HO2S Heater Low Control Bank 1 Sensor 2	I	—
2	0.5	VT / BU	5294	Powertrain Main Relay Fused Supply Voltage 5	I	—
3	0.5	WH / YE	3121	HO2S Low Signal Bank 1 Sensor 2	I	—
4	0.5	VT / BU	3120	HO2S High Signal Bank 1 Sensor 2	I	—

**B52E Heated Oxygen Sensor - Bank 2 Sensor 1 ((L84 / L87) & FJW)**

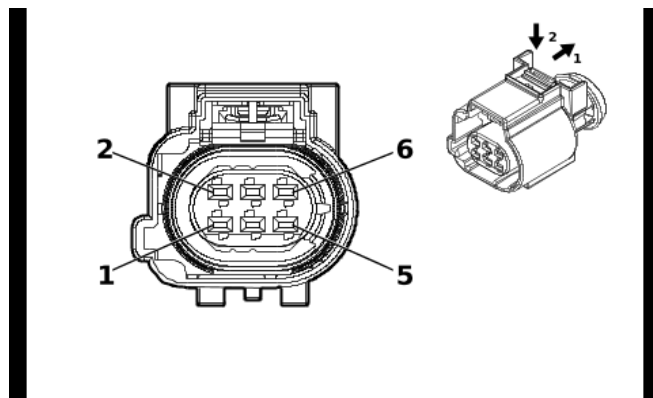

6312186

**Connector Part Information**

Harness Type: Engine Wiring Harness  
 OEM Connector: 13550230  
 Service Connector: Service by Harness - See Part Catalog  
 Description: 6-Way F 1.5 MCP Series, Sealed( BN)

**Terminal Part Information**

Terminal Type ID	Terminated Lead	Diagnostic Test Probe	Terminal Removal Tool
I	Not required	J-35616-14 (GN)	No Tool Required

**B52E Heated Oxygen Sensor - Bank 2 Sensor 1 ((L84 / L87) & FJW)**

Pin	Size	Color	Circuit	Function	Terminal Type ID	Option
1	0.5	YE / WH	2570	Heated Oxygen Sensor 2 Pump Current Signal	I	—
2	0.5	WH	2571	Heated Oxygen Sensor 2 Common Bank 2 Sensor 1 Signal	I	—
3	0.5	GN / YE	3212	HO2S Heater Low Control Bank 2 Sensor 1	I	—
4	0.5	VT / BU	5294	Powertrain Main Relay Fused Supply Voltage 5	I	—
5	0.5	BU	2572	Heated Oxygen Sensor 2 Current Adjust Signal	I	—
6	0.5	BN / GY	2573	Heated Oxygen Sensor 2 Collector Signal	I	—

**B52E Heated Oxygen Sensor - Bank 2 Sensor 1 (L84 & (FHR / FHS))**

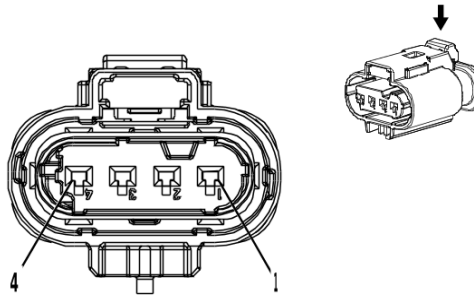

4381050

**Connector Part Information**

Harness Type: Engine Wiring Harness  
 OEM Connector: 10021267  
 Service Connector: 19354075  
 Description: 4-Way F 1.2 Multilock Series, Sealed( GY)

**Terminal Part Information**

Terminal Type ID	Terminated Lead	Diagnostic Test Probe	Terminal Removal Tool
I	Not required	J-35616-16 (L-GN)	No Tool Required

**B52E Heated Oxygen Sensor - Bank 2 Sensor 1 (L84 & (FHR / FHS))**

Pin	Size	Color	Circuit	Function	Terminal Type ID	Option
1	0.5	GN / YE	3212	HO2S Heater Low Control Bank 2 Sensor 1	I	—
2	0.5	VT / BU	5293	Powertrain Main Relay Fused Supply Voltage 4	I	—
3	0.5	YE / WH	3211	HO2S Low Signal Bank 2 Sensor 1	I	—
4	0.5	VT / WH	3210	HO2S High Signal Bank 2 Sensor 1	I	—

**B52F Heated Oxygen Sensor - Bank 2 Sensor 2**

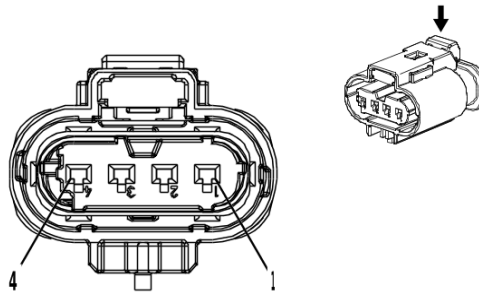

4036370

**Connector Part Information**

Harness Type: Engine Wiring Harness  
 OEM Connector: 10021266  
 Service Connector: 19330920  
 Description: 4-Way F 1.2 Multilock Series, Sealed( GY)

**Terminal Part Information**

Terminal Type ID	Terminated Lead	Diagnostic Test Probe	Terminal Removal Tool
I	Not required	J-35616-16 (L-GN)	No Tool Required

**B52F Heated Oxygen Sensor - Bank 2 Sensor 2**

Pin	Size	Color	Circuit	Function	Terminal Type ID	Option
1	0.5	WH / BN	3223	HO2S Heater Low Control Bank 2 Sensor 2	I	—
2	0.5	VT / BU	5294	Powertrain Main Relay Fused Supply Voltage 5	I	—
3	0.5	YE / BU	3221	HO2S Low Signal Bank 2 Sensor 2	I	—
4	0.5	VT / GN	3220	HO2S High Signal Bank 2 Sensor 2	I	—

## B55 Engine Compartment Cover Switch

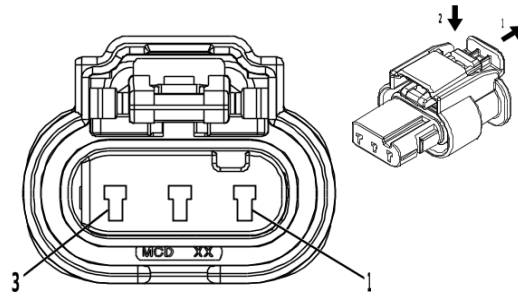

4421568

### Connector Part Information

Harness Type: Body Wiring Harness  
 OEM Connector: 34900-3120  
 Service Connector: 19368220  
 Description: 3-Way F 1.2 MCON-LL Series, Sealed( BK)

### Terminal Part Information

Terminal Type ID	Terminated Lead	Diagnostic Test Probe	Terminal Removal Tool
I	Not required	J-35616-16 (L-GN)	No Tool Required

### B55 Engine Compartment Cover Switch

Pin	Size	Color	Circuit	Function	Terminal Type ID	Option
1	0.5	YE	4063	Hood Status A Signal	I	—
2	0.35	BN / GN	4064	Hood Status B Signal	I	—
3	0.5	BK / WH	151	Signal Ground	I	—

**B58L Airbag Front End Discriminating Sensor - Left**

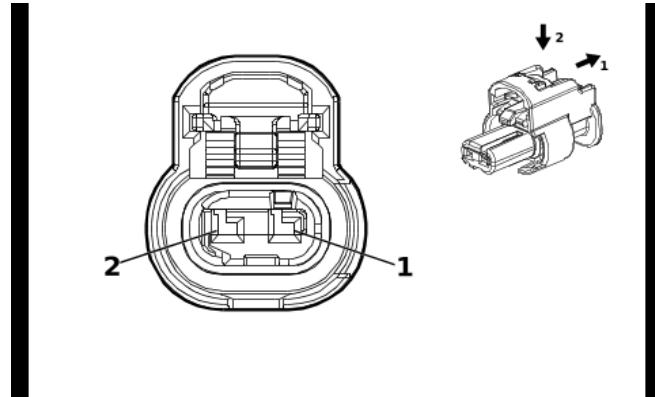

4649903

**Connector Part Information**

Harness Type: Body Wiring Harness  
 OEM Connector: 1-2296694-1  
 Service Connector: 85519075  
 Description: 2-Way F 1.2 MCON Series, Sealed( BK)

**Terminal Part Information**

Terminal Type ID	Terminated Lead	Diagnostic Test Probe	Terminal Removal Tool
I	Not required	J-35616-12 (BU)	No Tool Required

**B58L Airbag Front End Discriminating Sensor - Left**

Pin	Size	Color	Circuit	Function	Terminal Type ID	Option
1	0.5	OG / YE	354	Left Front Impact Discriminating Sensor Signal	I	—
2	0.5	BK / OG	5045	Left Front Impact Discriminating Sensor Low Reference	I	—

**B58R Airbag Front End Discriminating Sensor - Right**

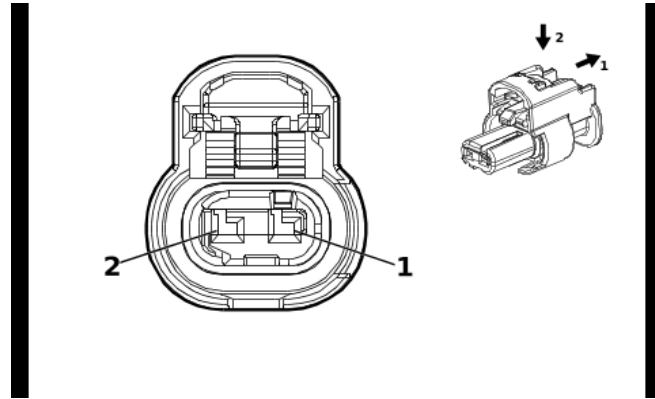

4649903

**Connector Part Information**

Harness Type: Body Wiring Harness  
 OEM Connector: 1-2296694-1  
 Service Connector: 85519075  
 Description: 2-Way F 1.2 MCON Series, Sealed( BK)

**Terminal Part Information**

Terminal Type ID	Terminated Lead	Diagnostic Test Probe	Terminal Removal Tool
I	Not required	J-35616-12 (BU)	No Tool Required

**B58R Airbag Front End Discriminating Sensor - Right**

Pin	Size	Color	Circuit	Function	Terminal Type ID	Option
1	0.5	OG / GN	1409	Right Front Impact Discriminating Sensor Signal	I	—
2	0.5	BK / OG	5600	Right Front Impact Discriminating Sensor Low Reference	I	—

**B61P Seat Belt Tension Sensor - Passenger**

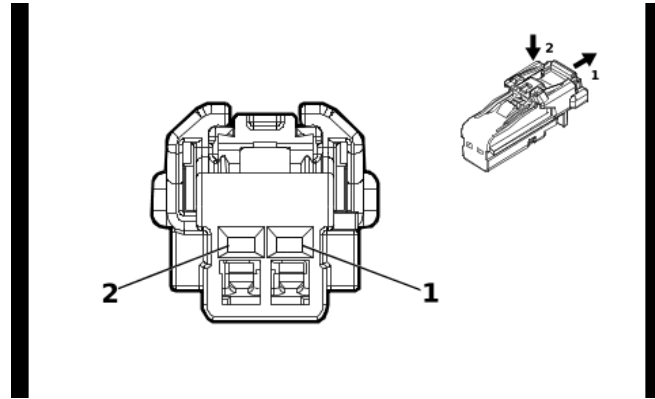

4115691

**Connector Part Information**

Harness Type: Body Wiring Harness  
 OEM Connector: 6098-8988  
 Service Connector: 87816612  
 Description: 2-Way F 1.2 MCON Series( BK)

**Terminal Part Information**

Terminal Type ID	Terminated Lead	Diagnostic Test Probe	Terminal Removal Tool
I	Not required	J-35616-12 (BU)	No Tool Required

**B61P Seat Belt Tension Sensor - Passenger**

Pin	Size	Color	Circuit	Function	Terminal Type ID	Option
1	0.35	GY / OG	3946	Passenger Automatic Locking Retractor Switch Low Reference	I	—
2	0.35	OG / BN	3947	Passenger Automatic Locking Retractor Switch Signal	I	—



**B63LF Airbag Side Impact Sensor - Left Front Door**

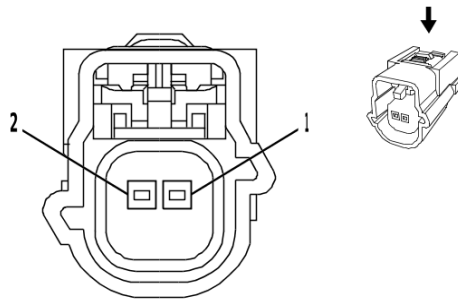

2179777

**Connector Part Information**

Harness Type: Front Side Door Door Wiring Harness - Driver  
 OEM Connector: 13610095  
 Service Connector: Service by Harness - See Part Catalog  
 Description: 2-Way F 0.64 Series, Sealed( GY)

**Terminal Part Information**

Terminal Type ID	Terminated Lead	Diagnostic Test Probe	Terminal Removal Tool
I	Not required	J-35616-64B (L-BU)	No Tool Required

**B63LF Airbag Side Impact Sensor - Left Front Door**

Pin	Size	Color	Circuit	Function	Terminal Type ID	Option
1	0.5	OG / GN	2132	Left Front Side Impact Sensor Signal	I	—
2	0.5	BK / OG	6628	Left Front Side Impact Sensor Low Reference	I	—

**B63LR Airbag Side Impact Rear Sensor - Left Door**

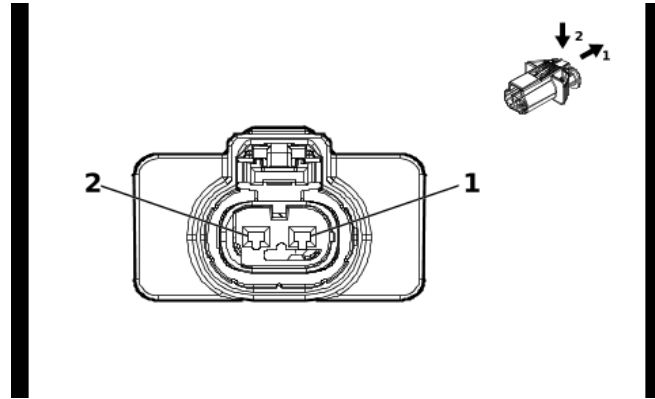

5877154

**Connector Part Information**

Harness Type: Rear Side Door Door Wiring Harness - Left Rear  
 OEM Connector: 35242148  
 Service Connector: Service by Harness - See Part Catalog  
 Description: 2-Way F 1.2 MLK Series, Sealed( BK)

**Terminal Part Information**

Terminal Type ID	Terminated Lead	Diagnostic Test Probe	Terminal Removal Tool
I	Not required	J-35616-16 (L-GN)	No Tool Required

**B63LR Airbag Side Impact Rear Sensor - Left Door**

Pin	Size	Color	Circuit	Function	Terminal Type ID	Option
1	0.5	OG / BU	6622	Left Rear Side Impact Sensor Signal	I	—
2	0.5	BK / OG	6623	Left Rear Side Impact Sensor Low Reference	I	—

**B63RF Airbag Side Impact Sensor - Right Front Door**

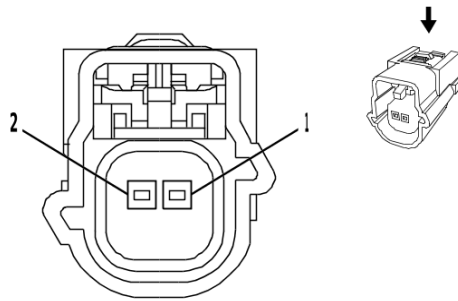

2179777

**Connector Part Information**

Harness Type: Front Side Door Door Wiring Harness - Passenger  
 OEM Connector: 13610095  
 Service Connector: Service by Harness - See Part Catalog  
 Description: 2-Way F 0.64 Series, Sealed( GY)

**Terminal Part Information**

Terminal Type ID	Terminated Lead	Diagnostic Test Probe	Terminal Removal Tool
I	Not required	J-35616-64B (L-BU)	No Tool Required

**B63RF Airbag Side Impact Sensor - Right Front Door**

Pin	Size	Color	Circuit	Function	Terminal Type ID	Option
1	0.5	BN / OG	2134	Right Front Side Impact Sensor Signal	I	—
2	0.5	BK / OG	6629	Right Front Side Impact Sensor Low Reference	I	—

**B63RR Airbag Side Impact Rear Sensor - Right Door**

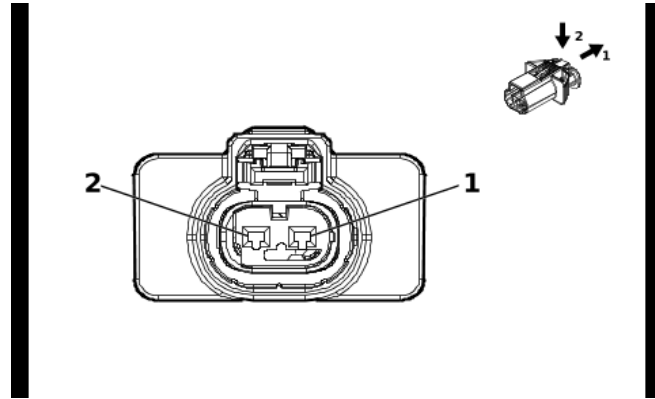

5877154

**Connector Part Information**

Harness Type: Rear Side Door Door Wiring Harness - Right Rear  
 OEM Connector: 35242148  
 Service Connector: Service by Harness - See Part Catalog  
 Description: 2-Way F 1.2 MLK Series, Sealed( BK)

**Terminal Part Information**

Terminal Type ID	Terminated Lead	Diagnostic Test Probe	Terminal Removal Tool
I	Not required	J-35616-16 (L-GN)	No Tool Required

**B63RR Airbag Side Impact Rear Sensor - Right Door**

Pin	Size	Color	Circuit	Function	Terminal Type ID	Option
1	0.5	OG / WH	6626	Right Rear Side Impact Sensor Signal	I	—
2	0.5	BK / OG	6627	Right Rear Side Impact Sensor Low Reference	I	—

**B65 Manifold Absolute Pressure and Intake Air Temperature Sensor (L3B)**

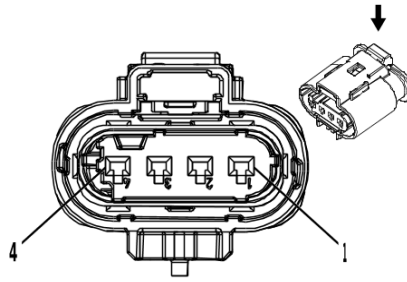

2717079

**Connector Part Information**

Harness Type: Engine Wiring Harness  
 OEM Connector: 10010346  
 Service Connector: 13587299  
 Description: 4-Way F 1.2 Multilock Series, Sealed( BK)

**Terminal Part Information**

Terminal Type ID	Terminated Lead	Diagnostic Test Probe	Terminal Removal Tool
I	Not required	J-35616-16 (L-GN)	No Tool Required

**B65 Manifold Absolute Pressure and Intake Air Temperature Sensor (L3B)**

Pin	Size	Color	Circuit	Function	Terminal Type ID	Option
1	0.5	WH / BU	7329	Pre-Throttle Air Temperature Signal	I	—
2	0.5	GY / RD	2704	Manifold Absolute Pressure Sensor 5V Reference	I	—
3	0.5	BK / GN	469	Manifold Absolute Pressure Sensor Low Reference	I	—
4	0.5	GN / WH	432	Manifold Absolute Pressure Sensor Signal	I	—

**B65 Manifold Absolute Pressure and Intake Air Temperature Sensor (LZ0)**

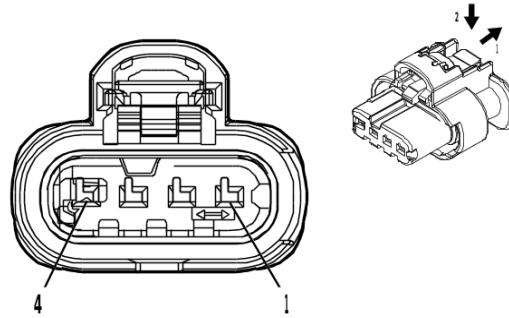

4934614

**Connector Part Information**

Harness Type: Engine Wiring Harness  
 OEM Connector: 1-2296696-2  
 Service Connector: 85519071  
 Description: 4-Way F 1.2 MCON-CB Series, Sealed( BK)

**Terminal Part Information**

Terminal Type ID	Terminated Lead	Diagnostic Test Probe	Terminal Removal Tool
I	Not required	J-35616-16 (L-GN)	No Tool Required

**B65 Manifold Absolute Pressure and Intake Air Temperature Sensor (LZ0)**

Pin	Size	Color	Circuit	Function	Terminal Type ID	Option
1	0.5	WH / BU	7329	Pre-Throttle Air Temperature Signal	I	—
2	0.5	WH / RD	480	Engine Control Vehicle Sensors 5 Volt Reference 1	I	—
3	0.5	BK / GN	580	Engine Control Sensors Low Reference 2	I	—
4	0.5	GN / WH	432	Manifold Absolute Pressure Sensor Signal	I	—

**B68A Knock Sensor 1 (L3B)**

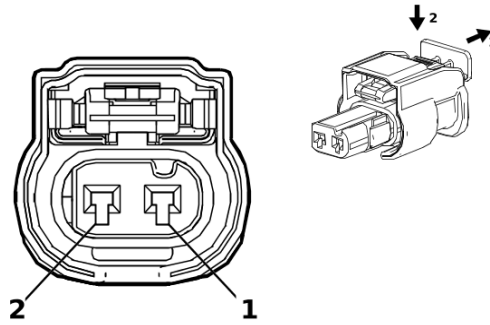

3960139

**Connector Part Information**

Harness Type: Fuel Injector Wiring Harness  
 OEM Connector: 34900-2120  
 Service Connector: Service by Harness - See Part Catalog  
 Description: 2-Way F 1.2 MCON Series, Sealed( BK)

**Terminal Part Information**

Terminal Type ID	Terminated Lead	Diagnostic Test Probe	Terminal Removal Tool
I	Not required	J-35616-12 (BU)	No Tool Required

**B68A Knock Sensor 1 (L3B)**

Pin	Size	Color	Circuit	Function	Terminal Type ID	Option
1	0.5	VT / GY	496	Knock Sensor 1 Signal	I	—
2	0.5	BK / YE	1716	Knock Sensor Low Reference 1	I	—

**B68A Knock Sensor 1 (L84 / L87)**

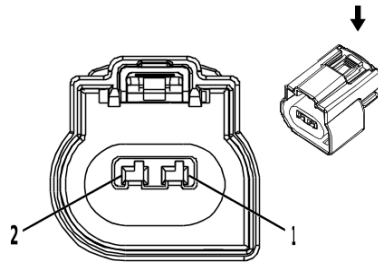

2717073

**Connector Part Information**

Harness Type: Engine Wiring Harness  
 OEM Connector: 34752-0204  
 Service Connector: 19301207  
 Description: 2-Way F 1.5 MX Series, Sealed( BK)

**Terminal Part Information**

Terminal Type ID	Terminated Lead	Diagnostic Test Probe	Terminal Removal Tool
I	Not required	J-35616-14 (GN)	No Tool Required

**B68A Knock Sensor 1 (L84 / L87)**

Pin	Size	Color	Circuit	Function	Terminal Type ID	Option
1	0.75	VT / GY	496	Knock Sensor 1 Signal	I	—
2	0.75	BK / YE	1716	Knock Sensor Low Reference 1	I	—



**B68B Knock Sensor 2 (L3B)**

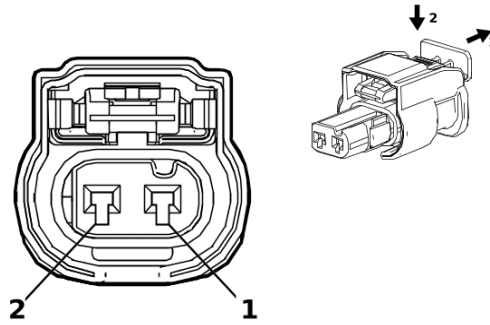

3960139

**Connector Part Information**

Harness Type: Fuel Injector Wiring Harness  
 OEM Connector: 34900-2120  
 Service Connector: Service by Harness - See Part Catalog  
 Description: 2-Way F 1.2 MCON Series, Sealed( BK)

**Terminal Part Information**

Terminal Type ID	Terminated Lead	Diagnostic Test Probe	Terminal Removal Tool
I	Not required	J-35616-12 (BU)	No Tool Required

**B68B Knock Sensor 2 (L3B)**

Pin	Size	Color	Circuit	Function	Terminal Type ID	Option
1	0.5	WH / GY	1876	Knock Sensor 2 Signal	I	—
2	0.5	BK / GY	2303	Knock Sensor Low Reference 2	I	—

**B68B Knock Sensor 2 (L84 / L87)**

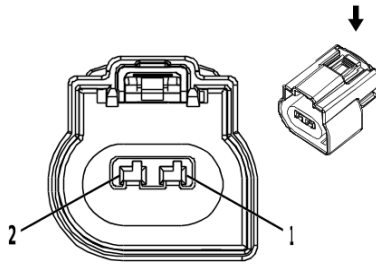

2717073

**Connector Part Information**

Harness Type: Engine Wiring Harness  
 OEM Connector: 34752-0204  
 Service Connector: 19301207  
 Description: 2-Way F 1.5 MX Series, Sealed( BK)

**Terminal Part Information**

Terminal Type ID	Terminated Lead	Diagnostic Test Probe	Terminal Removal Tool
I	Not required	J-35616-14 (GN)	No Tool Required

**B68B Knock Sensor 2 (L84 / L87)**

Pin	Size	Color	Circuit	Function	Terminal Type ID	Option
1	0.75	WH / GY	1876	Knock Sensor 2 Signal	I	—
2	0.75	BK / GY	2303	Knock Sensor Low Reference 2	I	—

## B74 Manifold Absolute Pressure Sensor

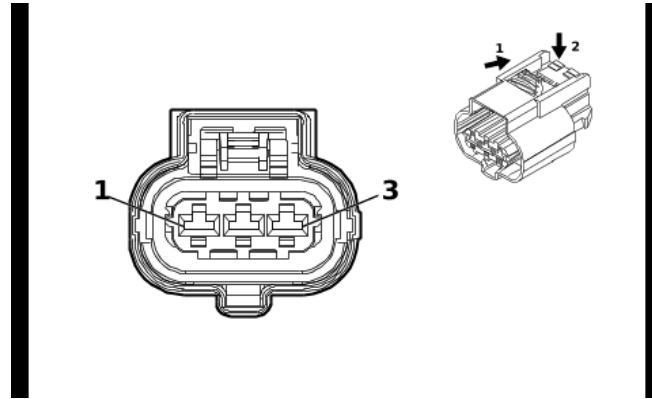

4900977

### Connector Part Information

Harness Type: Engine Wiring Harness  
 OEM Connector: 35133579  
 Service Connector: 84815530  
 Description: 3-Way F 2.8 CTS Series, Sealed( BK)

### Terminal Part Information

Terminal Type ID	Terminated Lead	Diagnostic Test Probe	Terminal Removal Tool
I	Not required	J-35616-35 (VT)	No Tool Required

### B74 Manifold Absolute Pressure Sensor

Pin	Size	Color	Circuit	Function	Terminal Type ID	Option
1	0.5	GY / RD	2704	Manifold Absolute Pressure Sensor 5V Reference	I	—
2	0.5	BK / GN	469	Manifold Absolute Pressure Sensor Low Reference	I	—
3	0.5	GN / WH	432	Manifold Absolute Pressure Sensor Signal	I	—

**B75 Mass Airflow Sensor**

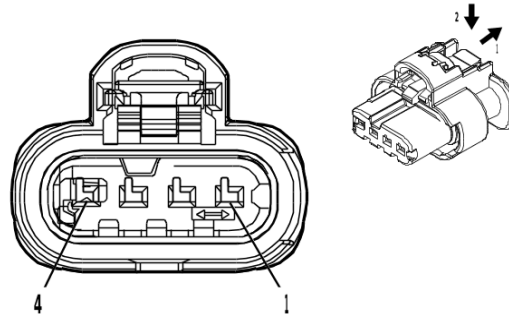

4934614

**Connector Part Information**

Harness Type: Engine Wiring Harness  
 OEM Connector: 1-2296696-2  
 Service Connector: 85519071  
 Description: 4-Way F 1.2 MCON-CB Series, Sealed( BK)

**Terminal Part Information**

Terminal Type ID	Terminated Lead	Diagnostic Test Probe	Terminal Removal Tool
I	Not required	J-35616-16 (L-GN)	No Tool Required

**B75 Mass Airflow Sensor**

Pin	Size	Color	Circuit	Function	Terminal Type ID	Option
1	0.5	VT / BU	5294	Powertrain Main Relay Fused Supply Voltage 5	I	—
2	0.5	GN / WH	492	Mass Air Flow Sensor Signal	I	—
3	0.5	GN / YE	4622	Engine Control Module LIN Bus 2	I	—
4	0.5	BK	6550	Ground	I	L3B
	0.75	BK / WH	251	Signal Ground	I	L84 / L87 / LZ0

**B87 Rearview Driver Information Camera (UV2)**

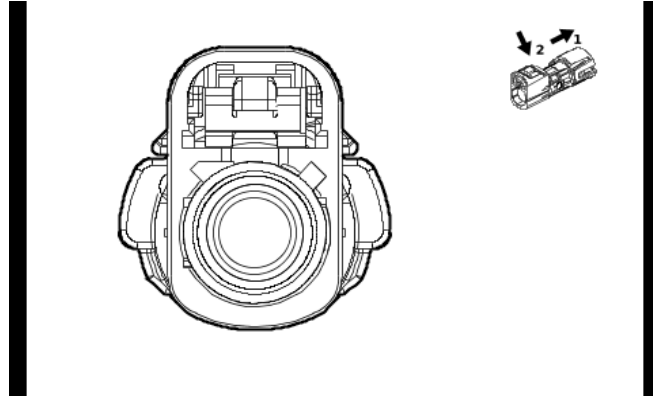

5758030

**Connector Part Information**

Harness Type: Endgate Wiring Harness COAX  
 OEM Connector: 35187032  
 Service Connector: Service by Cable Assembly — See Part Catalog  
 Description: 1-Way F Coax Type( BK)

**Terminal Part Information**

Terminal Type ID	Terminated Lead	Diagnostic Test Probe	Terminal Removal Tool
I	Not required	No Tool Required	No Tool Required

**B87 Rearview Driver Information Camera (UV2)**

Pin	Size	Color	Circuit	Function	Terminal Type ID	Option
—	—	Coax Cable	—	Rear Vision Camera Coaxial Video Signal	I	—

**B87 Rearview Driver Information Camera (UVB)**

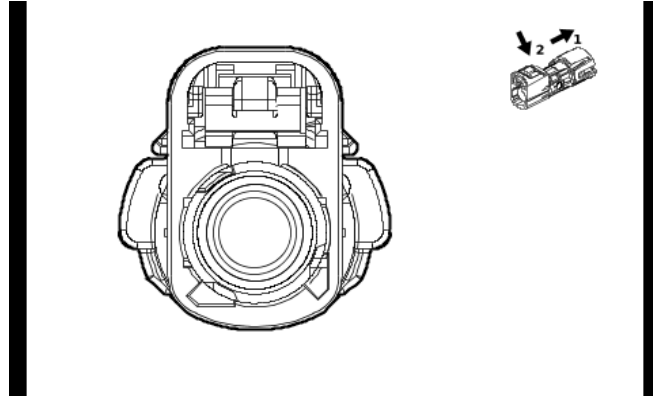

5757455

**Connector Part Information**

Harness Type: Endgate Wiring Harness COAX  
 OEM Connector: 35187043  
 Service Connector: Service by Cable Assembly — See Part Catalog  
 Description: 1-Way F Coax Type( OG)

**Terminal Part Information**

Terminal Type ID	Terminated Lead	Diagnostic Test Probe	Terminal Removal Tool
I	Not required	No Tool Required	No Tool Required

**B87 Rearview Driver Information Camera (UVB)**

Pin	Size	Color	Circuit	Function	Terminal Type ID	Option
—	—	Coax Cable	—	Rear Vision Camera Coaxial Video Signal	I	—

**B87CA Auxiliary Rearview Camera - Cargo Area (UVN)**

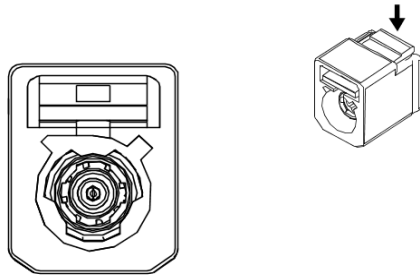

3293633

**Connector Part Information**

Harness Type: Inside Rearview Mirror Wiring Harness - Jumper COAX  
 OEM Connector: 3FA1ENARJ-C01ER  
 Service Connector: Service by Cable Assembly — See Part Catalog  
 Description: 1-Way F Coax Type( BK)

**Terminal Part Information**

Terminal Type ID	Terminated Lead	Diagnostic Test Probe	Terminal Removal Tool
I	Not required	No Tool Required	No Tool Required

**B87CA Auxiliary Rearview Camera - Cargo Area (UVN)**

Pin	Size	Color	Circuit	Function	Terminal Type ID	Option
—	—	Coax Cable	—	Cargo Bed Rear Vision Camera Coaxial Video Signal	I	—

**B88D Seat Belt Switch - Driver**

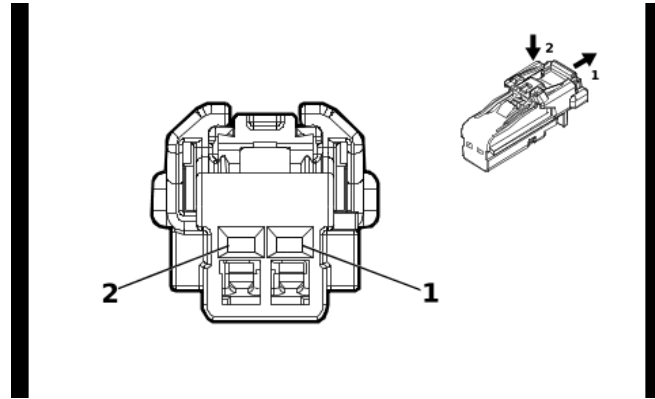

4115691

**Connector Part Information**

Harness Type: Front Seat Wiring Harness - Driver  
 OEM Connector: 6098-8988  
 Service Connector: Service by Harness - See Part Catalog  
 Description: 2-Way F 1.2 MCON Series( BK)

**Terminal Part Information**

Terminal Type ID	Terminated Lead	Diagnostic Test Probe	Terminal Removal Tool
I	Not required	J-35616-16 (L-GN)	No Tool Required

**B88D Seat Belt Switch - Driver**

Pin	Size	Color	Circuit	Function	Terminal Type ID	Option
1	0.5	BK / OG	1363	Driver Seat Belt Switch Low Reference	I	—
2	0.5	OG / GY	2652	Driver Seat Belt Sensor Signal	I	—



## B88P Seat Belt Switch - Passenger

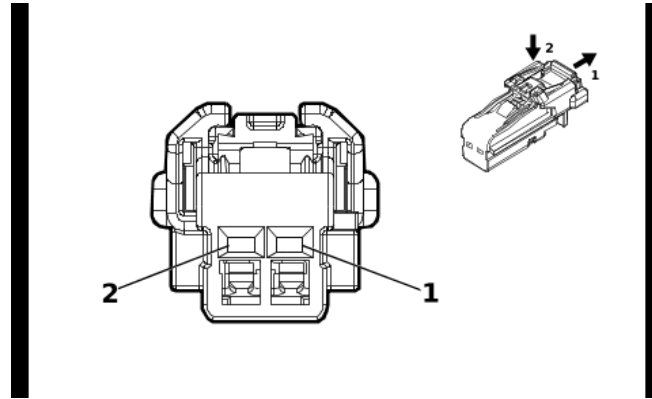

4115691

### Connector Part Information

Harness Type: Front Seat Wiring Harness - Passenger  
 OEM Connector: 6098-8988  
 Service Connector: Service by Harness - See Part Catalog  
 Description: 2-Way F 1.2 MCON Series( BK)

### Terminal Part Information

Terminal Type ID	Terminated Lead	Diagnostic Test Probe	Terminal Removal Tool
I	Not required	J-35616-16 (L-GN)	No Tool Required

### B88P Seat Belt Switch - Passenger

Pin	Size	Color	Circuit	Function	Terminal Type ID	Option
1	0.5	BK / OG	1363	Driver Seat Belt Switch Low Reference	I	—
2	0.5	OG / VT	1362	Passenger Seat Belt Switch Signal	I	—

**B96 Cylinder Head Temperature Sensor**

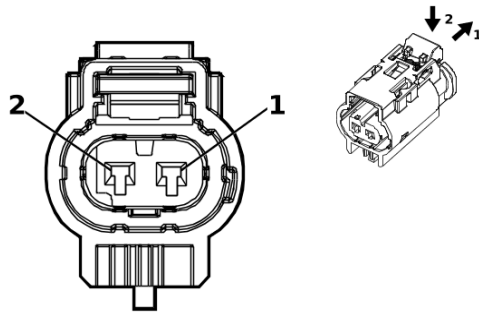

3747580

**Connector Part Information**

Harness Type: Engine Wiring Harness  
 OEM Connector: 10094236  
 Service Connector: 19332627  
 Description: 2-Way F 1.2 Multilock Series, Sealed( GY)

**Terminal Part Information**

Terminal Type ID	Terminated Lead	Diagnostic Test Probe	Terminal Removal Tool
I	Not required	J-35616-16 (L-GN)	No Tool Required

**B96 Cylinder Head Temperature Sensor**

Pin	Size	Color	Circuit	Function	Terminal Type ID	Option
1	0.5	GN / YE	37	Engine Block Temperature Sensor Signal	I	—
2	0.5	BK / GN	580	Engine Control Sensors Low Reference 2	I	—

## B107 Accelerator Pedal Position Sensor

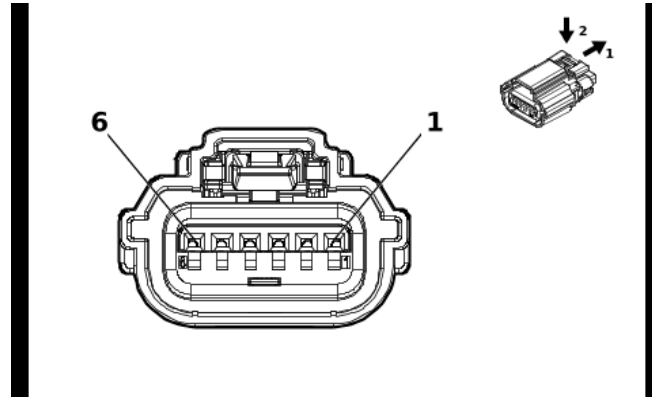

5921819

### Connector Part Information

Harness Type: Body Wiring Harness  
 OEM Connector: 35390637  
 Service Connector: 86825466  
 Description: 6-Way F 0.64 OCS Series, Sealed( BK)

### Terminal Part Information

Terminal Type ID	Terminated Lead	Diagnostic Test Probe	Terminal Removal Tool
I	Not required	J-35616-64B (L-BU)	No Tool Required

### B107 Accelerator Pedal Position Sensor

Pin	Size	Color	Circuit	Function	Terminal Type ID	Option
1	0.35	WH / RD	1164	Accelerator Pedal Position 5V Reference 1	I	—
2	0.35	YE / WH	1161	Accelerator Pedal Position Signal 1	I	—
3	0.35	BK / BU	1271	Accelerator Pedal Position Low Reference 1	I	—
4	0.35	BK / VT	1272	Accelerator Pedal Position Low Reference 2	I	—
5	0.35	GN / WH	1162	Accelerator Pedal Position Signal 2	I	—
6	0.35	BN / RD	1274	Accelerator Pedal Position 5V Reference 2	I	—

**B110 Battery Monitor Module X1**

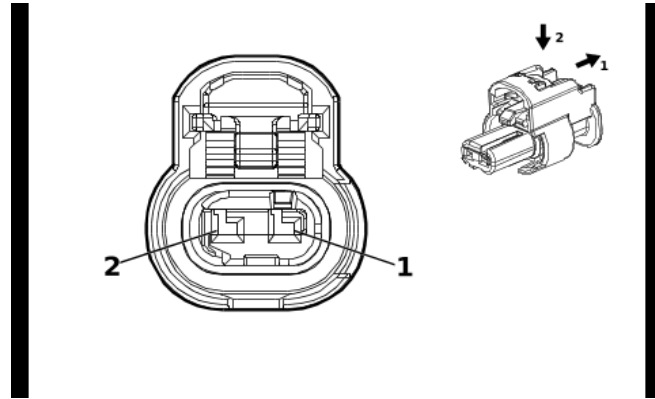

4649903

**Connector Part Information**

Harness Type: Body Wiring Harness  
 OEM Connector: 1-2296694-1  
 Service Connector: 85519075  
 Description: 2-Way F 1.2 MCON Series, Sealed( BK)

**Terminal Part Information**

Terminal Type ID	Terminated Lead	Diagnostic Test Probe	Terminal Removal Tool
I	Not required	J-35616-12 (BU)	No Tool Required

**B110 Battery Monitor Module X1**

Pin	Size	Color	Circuit	Function	Terminal Type ID	Option
1	0.35	GN / YE	2855	Body Control Module LIN Bus 9	I	—
2	0.75	RD / YE	2340	Battery Positive Voltage	I	—

## B110 Battery Monitor Module X2 (L3B / L84 / L87)

—

### Connector Part Information

Harness Type: Battery Negative Cable  
 OEM Connector: 13516387  
 Service Connector: Service by Cable Assembly — See Part Catalog  
 Description: 1-Way F Ring Terminal

### Terminal Part Information

Terminal Type ID	Terminated Lead	Diagnostic Test Probe	Terminal Removal Tool
I	Not required	No Tool Required	No Tool Required

### B110 Battery Monitor Module X2 (L3B / L84 / L87)

Pin	Size	Color	Circuit	Function	Terminal Type ID	Option
A	50	BK	550	Ground	I	—

**B110 Battery Monitor Module X2 (LZ0)**

**Connector Part Information**

Harness Type: Battery Negative Cable  
 OEM Connector: 13516387  
 Service Connector: Service by Cable Assembly — See Part Catalog  
 Description: 1-Way F Ring Terminal

**Terminal Part Information**

Terminal Type ID	Terminated Lead	Diagnostic Test Probe	Terminal Removal Tool
I	Not required	No Tool Required	No Tool Required

**B110 Battery Monitor Module X2 (LZ0)**

Pin	Size	Color	Circuit	Function	Terminal Type ID	Option
A	50	BK	550	Ground	I	—

## B111 Turbocharger/Supercharger Boost Pressure Sensor

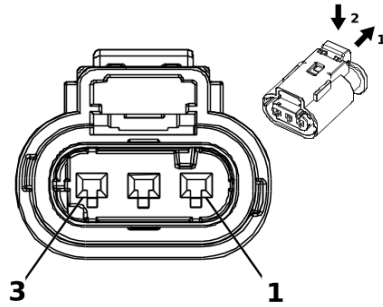

2717069

### Connector Part Information

Harness Type: Engine Wiring Harness  
 OEM Connector: 10010341  
 Service Connector: 84601390  
 Description: 3-Way F 1.2 Multilock Series, Sealed( BK)

### Terminal Part Information

Terminal Type ID	Terminated Lead	Diagnostic Test Probe	Terminal Removal Tool
I	Not required	J-35616-16 (L-GN)	No Tool Required

### B111 Turbocharger/Supercharger Boost Pressure Sensor

Pin	Size	Color	Circuit	Function	Terminal Type ID	Option
1	0.5	BU / RD	460	Engine Control Sensors 5 Volt Reference 1	I	—
2	0.5	BK / YE	548	Engine Control Sensors Low Reference 1	I	—
3	0.5	YE / WH	3200	Throttle Inlet Absolute Pressure Sensor Signal	I	—

**B117A Windshield Outside Moisture/Ambient Light and Humidity Sensor (ASV & CE1)**

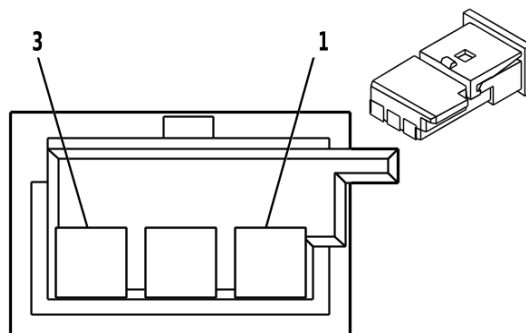

647970

**Connector Part Information**

Harness Type: Headlamp Automatic Control Ambient Light Sensor Wiring Harness  
 OEM Connector: 13153088  
 Service Connector: Service by Harness - See Part Catalog  
 Description: 3-Way F 0.64 Micro-Quadlock Series( BK)

**Terminal Part Information**

Terminal Type ID	Terminated Lead	Diagnostic Test Probe	Terminal Removal Tool
I	Not required	J-35616-64B (L-BU)	No Tool Required

**B117A Windshield Outside Moisture/Ambient Light and Humidity Sensor (ASV & CE1)**

Pin	Size	Color	Circuit	Function	Terminal Type ID	Option
1	0.35	RD / VT	339	Run/Crank Ignition 1 Voltage	I	—
2	0.35	GN / BN	4115	Body Control Module LIN Bus 5	I	—
3	0.35	BK	851	Signal Ground	I	—



**B118 Windshield Washer Solvent Container Level Sensor**

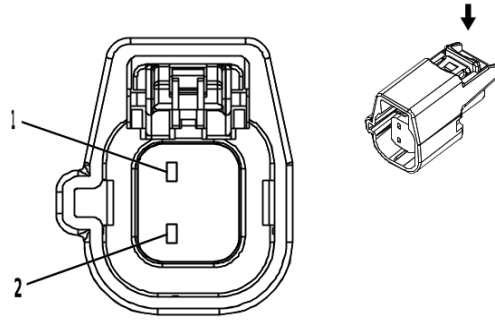

3958652

**Connector Part Information**

Harness Type: Body Wiring Harness  
 OEM Connector: 7287-8378-40  
 Service Connector: 13593220  
 Description: 2-Way F 1.5 Series, Sealed( L-GY)

**Terminal Part Information**

Terminal Type ID	Terminated Lead	Diagnostic Test Probe	Terminal Removal Tool
I	Not required	J-35616-14 (GN)	No Tool Required

**B118 Windshield Washer Solvent Container Level Sensor**

Pin	Size	Color	Circuit	Function	Terminal Type ID	Option
1	0.35	VT	185	Low Washer Fluid Indicator Control	I	—
2	0.5	BK / WH	151	Signal Ground	I	—

**B130C Exhaust Gas Recirculation Temperature Sensor 3**

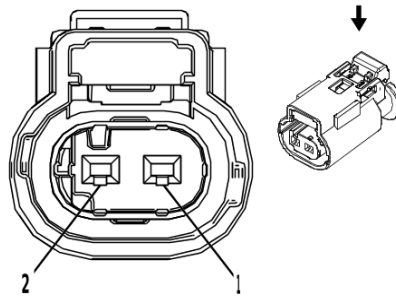

2830969

**Connector Part Information**

Harness Type: Engine Wiring Harness  
 OEM Connector: 10010339  
 Service Connector: 13587321  
 Description: 2-Way F 1.2 Multilock Series, Sealed( D-GY)

**Terminal Part Information**

Terminal Type ID	Terminated Lead	Diagnostic Test Probe	Terminal Removal Tool
I	Not required	J-35616-16 (L-GN)	No Tool Required

**B130C Exhaust Gas Recirculation Temperature Sensor 3**

Pin	Size	Color	Circuit	Function	Terminal Type ID	Option
1	0.5	BK / GN	3235	Exhaust Gas Recirculation Temperature Sensor 3 Low Reference	I	—
2	0.5	WH / GY	3234	Exhaust Gas Recirculation Temperature Sensor 3 Signal	I	—

**B136 Exhaust Particulate Matter Sensor (LM2)**

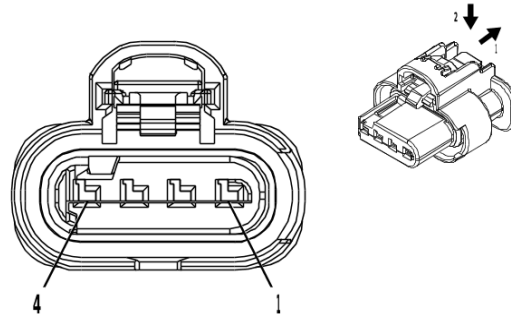

4210809

**Connector Part Information**

Harness Type: Chassis Wiring Harness  
 OEM Connector: 1-2296696-1  
 Service Connector: 85518225  
 Description: 4-Way F 1.2 MCON-CB Series, Sealed( BK)

**Terminal Part Information**

Terminal Type ID	Terminated Lead	Diagnostic Test Probe	Terminal Removal Tool
I	Not required	J-35616-16 (L-GN)	No Tool Required

**B136 Exhaust Particulate Matter Sensor (LM2)**

Pin	Size	Color	Circuit	Function	Terminal Type ID	Option
1	1	BK / WH	1151	Signal Ground	I	—
2	0.5	BU / GY	4054	Private Serial Data Powertrain CAN Bus [-] Serial Data	I	—
3	0.5	WH	4055	Private Serial Data Powertrain CAN Bus [+] Serial Data	I	—
4	1	VT / GN	4320	Powertrain Sensor Bus Enable	I	—

**B137B Power Steering Shaft Torque/Position Sensor**

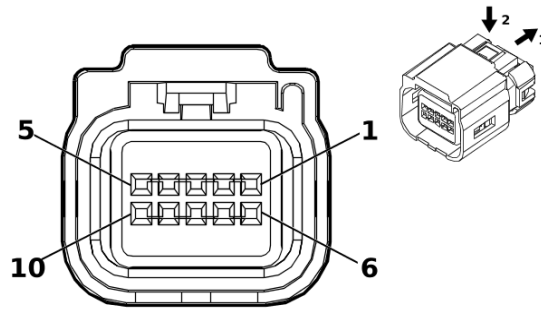

3608469

**Connector Part Information**

Harness Type: Power Steering Control Module Wiring Harness - Shaft Sensor  
 OEM Connector: 13587225  
 Service Connector: Service by Harness - See Part Catalog  
 Description: 10-Way F 0.64 Kaizen Series, Sealed( GY)

**Terminal Part Information**

Terminal Type ID	Terminated Lead	Diagnostic Test Probe	Terminal Removal Tool
I	Not required	J-35616-64B (L-BU)	No Tool Required

**B137B Power Steering Shaft Torque/Position Sensor**

Pin	Size	Color	Circuit	Function	Terminal Type ID	Option
1	0.5	BU	8367	Handwheel Channel A Torque Pressure Sensor 1 SENT Signal	I	—
2	0.5	RD	8366	Handwheel Channel A High Reference	I	—
3	0.5	BK	8370	Handwheel Channel A Low Reference	I	—
4	0.5	WH / RD	8371	Handwheel Channel B High Reference	I	—
5	0.5	WH / BU	8372	Handwheel Channel B Torque Pressure Sensor 1 SENT Signal	I	—
6	0.5	VT	8368	Handwheel Channel A Torque Pressure Sensor 2 SENT Signal	I	—
7	0.5	OG	8369	Handwheel Channel A Angle Position Sensor SENT Signal	I	—
8	0.5	GY	8375	Handwheel Channel B Low Reference	I	—
9	0.5	YE	8374	Handwheel Channel B Angle Position Sensor SENT Signal	I	—
10	0.5	GN	8373	Handwheel Channel B Torque Pressure Sensor 2 SENT Signal	I	—

**B139 Transfer Case Two/Four Wheel Drive Actuator Position Sensor (NP0 / NQH)**

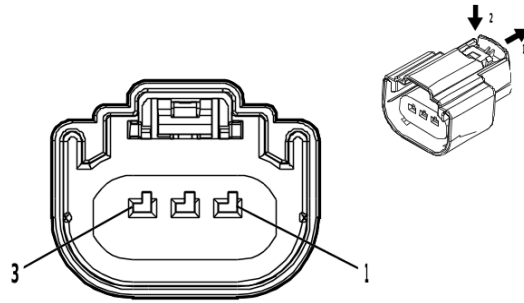

4569745

**Connector Part Information**

Harness Type: Engine Wiring Harness  
 OEM Connector: 33343869  
 Service Connector: 19179750  
 Description: 3-Way F 1.5 MX Series, Sealed( BK)

**Terminal Part Information**

Terminal Type ID	Terminated Lead	Diagnostic Test Probe	Terminal Removal Tool
I	Not required	J-35616-2A (GY)	No Tool Required

**B139 Transfer Case Two/Four Wheel Drive Actuator Position Sensor (NP0 / NQH)**

Pin	Size	Color	Circuit	Function	Terminal Type ID	Option
1	0.5	WH / RD	7477	Gear Position Sensor 5V Reference	I	—
2	0.5	WH / GN	7479	Rotary Position Sensor Signal	I	—
3	0.5	YE / BK	7478	Gear Position Sensor Low Reference	I	—

**B150 Fuel Tank Pressure Sensor**

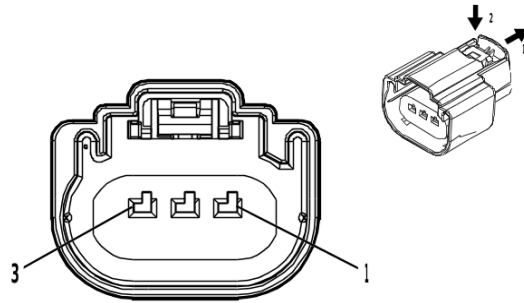

4589538

**Connector Part Information**

Harness Type: Chassis Wiring Harness  
 OEM Connector: 160073-3106  
 Service Connector: 84569854  
 Description: 3-Way F 1.5 MX Series, Sealed( GY)

**Terminal Part Information**

Terminal Type ID	Terminated Lead	Diagnostic Test Probe	Terminal Removal Tool
I	Not required	J-35616-14 (GN)	No Tool Required

**B150 Fuel Tank Pressure Sensor**

Pin	Size	Color	Circuit	Function	Terminal Type ID	Option
1	0.5	BU / GN	890	Fuel Tank Pressure Sensor Signal	I	FHS
	0.5	BU / WH	890	Fuel Tank Pressure Sensor Signal	I	FJW
2	0.5	BK / BN	6284	Fuel Tank Pressure Sensor Low Reference	I	—
3	0.5	YE / RD	2709	Fuel Tank Pressure Sensor 5V Reference	I	—

**B160 Inside Air Moisture and Windshield Temperature Sensor (ASV - CE1)**

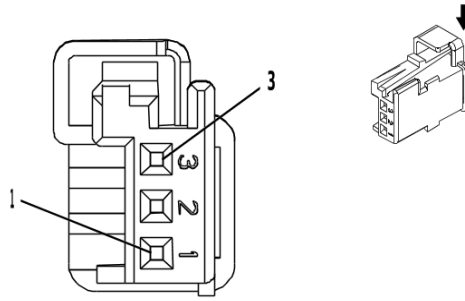

4218883

**Connector Part Information**

Harness Type: Inside Rearview Mirror Wiring Harness - Jumper  
 OEM Connector: 13593004  
 Service Connector: Service by Harness - See Part Catalog  
 Description: 3-Way F 0.64 Micro-Quadlock Series( BK)

**Terminal Part Information**

Terminal Type ID	Terminated Lead	Diagnostic Test Probe	Terminal Removal Tool
I	Not required	J-35616-64B (L-BU)	No Tool Required

**B160 Inside Air Moisture and Windshield Temperature Sensor (ASV - CE1)**

Pin	Size	Color	Circuit	Function	Terminal Type ID	Option
1	0.35	VT / BK	339	Run/Crank Ignition 1 Voltage	I	—
2	0.35	BK / WH	851	Signal Ground	I	—
3	0.35	GN / WH	4115	Body Control Module LIN Bus 5	I	—

**B172LF Front Disc Brake Pad Wear Sensor - Left (JBP)**

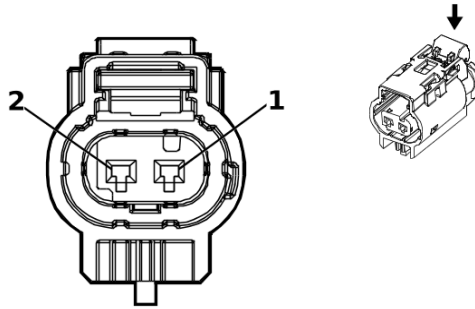

3747581

**Connector Part Information**

Harness Type: Chassis Wiring Harness  
 OEM Connector: 10094234  
 Service Connector: 84727362  
 Description: 2-Way F 1.2 Multilock Series, Sealed( BK)

**Terminal Part Information**

Terminal Type ID	Terminated Lead	Diagnostic Test Probe	Terminal Removal Tool
I	Not required	J-35616-16 (L-GN)	No Tool Required

**B172LF Front Disc Brake Pad Wear Sensor - Left (JBP)**

Pin	Size	Color	Circuit	Function	Terminal Type ID	Option
1	0.5	BN / BU	1602	Front Brake Pad Wear Sensor Signal	I	—
2	0.5	BK / WH	1151	Signal Ground	I	—



**B172LR Rear Disc Brake Pad Wear Sensor - Left**

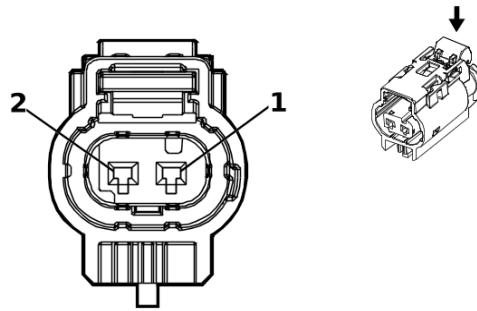

3747581

**Connector Part Information**

Harness Type: Chassis Rear Wiring Harness Extension Harness  
 OEM Connector: 13583195  
 Service Connector: Service by Harness - See Part Catalog  
 Description: 2-Way F 1.2 Multilock Series, Sealed( BK)

**Terminal Part Information**

Terminal Type ID	Terminated Lead	Diagnostic Test Probe	Terminal Removal Tool
I	Not required	J-35616-16 (L-GN)	No Tool Required

**B172LR Rear Disc Brake Pad Wear Sensor - Left**

Pin	Size	Color	Circuit	Function	Terminal Type ID	Option
1	0.75	GN / YE	1616	Rear Brake Pad Wear Sensor Signal	I	- Z45
	0.75	GN / YE	1616	Rear Brake Pad Wear Sensor Signal	I	Z45+ G94
2	0.75	BK / WH	1951	Signal Ground	I	- Z45
	0.75	BK / WH	1751	Signal Ground	I	Z45+ G94

**B174G Front View Driver Information Camera - Grille (- GRZ)**

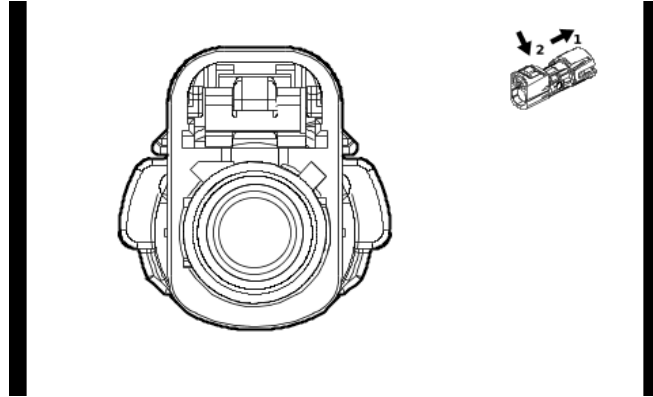

5758030

**Connector Part Information**

Harness Type: Front View Camera Switch Wiring Harness COAX  
 OEM Connector: 35187032  
 Service Connector: Service by Cable Assembly — See Part Catalog  
 Description: 1-Way F Coax Type( BK)

**Terminal Part Information**

Terminal Type ID	Terminated Lead	Diagnostic Test Probe	Terminal Removal Tool
I	Not required	No Tool Required	No Tool Required

**B174G Front View Driver Information Camera - Grille (- GRZ)**

Pin	Size	Color	Circuit	Function	Terminal Type ID	Option
—	—	Coax Cable	—	Front Vision Camera 1 Coaxial Video Signal	I	—

**B174G Front View Driver Information Camera - Grille (GRZ)**

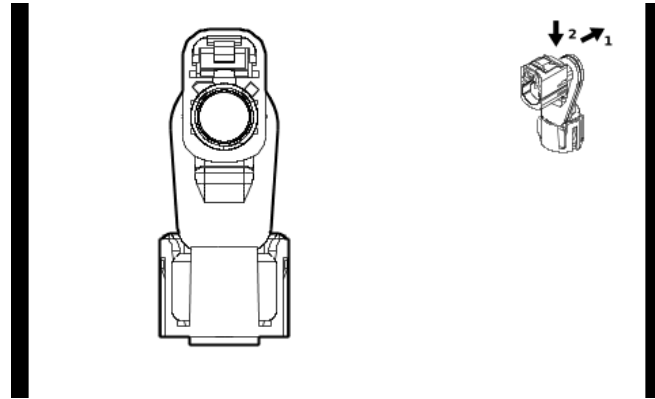

5920539

**Connector Part Information**

Harness Type: Front View Camera Switch Wiring Harness COAX  
 OEM Connector: 35339728  
 Service Connector: Service by Cable Assembly — See Part Catalog  
 Description: 1-Way F Coax Type( BK)

**Terminal Part Information**

Terminal Type ID	Terminated Lead	Diagnostic Test Probe	Terminal Removal Tool
I	Not required	No Tool Required	No Tool Required

**B174G Front View Driver Information Camera - Grille (GRZ)**

Pin	Size	Color	Circuit	Function	Terminal Type ID	Option
—	—	Coax Cable	—	Front Vision Camera 1 Coaxial Video Signal	I	—

**B174W Front View Camera - Windshield**

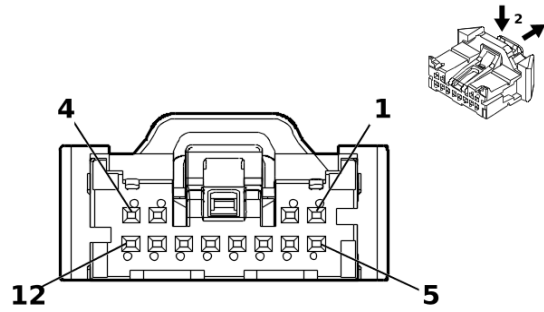

5360826

**Connector Part Information**

Harness Type: Dome Lamp Wiring Harness  
 OEM Connector: 35068239  
 Service Connector: 13529935  
 Description: 12-Way F 050 CTS Series( BK)

**Terminal Part Information**

Terminal Type ID	Terminated Lead	Diagnostic Test Probe	Terminal Removal Tool
I	84944580	EL-35616-58 (BK)	EL-38125-58

**B174W Front View Camera - Windshield**

Pin	Size	Color	Circuit	Function	Terminal Type ID	Option
1	0.35	BK / WH	851	Signal Ground	I	—
2	—	—	—	Not Occupied	—	—
3	0.35	RD / YE	240	Battery Positive Voltage	I	—
4	—	—	—	Not Occupied	—	—
5	0.35	BU / GY	4105	AUTOSAR CAN Bus [+] 8 Serial Data	I	UGN- GF2- GF5- GPZ
	0.35	BU / YE	4979	AUTOSAR CAN Bus [+] 2 Serial Data	I	UHY+ ( GF2/ GF5/ GPZ)
6	0.35	WH / GY	4104	AUTOSAR CAN Bus [-] 8 Serial Data	I	UGN- GF2- GF5- GPZ
	0.35	WH	4978	AUTOSAR CAN Bus [-] 2 Serial Data	I	UHY+ ( GF2/ GF5/ GPZ)
7	0.35	BU / GY	4105	AUTOSAR CAN Bus [+] 8 Serial Data	I	UGN- GF2- GF5- GPZ
	0.35	BU / YE	4979	AUTOSAR CAN Bus [+] 2 Serial Data	I	UHY+ ( GF2/ GF5/ GPZ)
8	0.35	WH / GY	4104	AUTOSAR CAN Bus [-] 8 Serial Data	I	UGN- GF2- GF5- GPZ
	0.35	WH	4978	AUTOSAR CAN Bus [-] 2 Serial Data	I	UHY+ ( GF2/ GF5/ GPZ)
9 - 12	—	—	—	Not Occupied	—	—

**B193A Charge Air Cooler Air Temperature Sensor - Inlet**

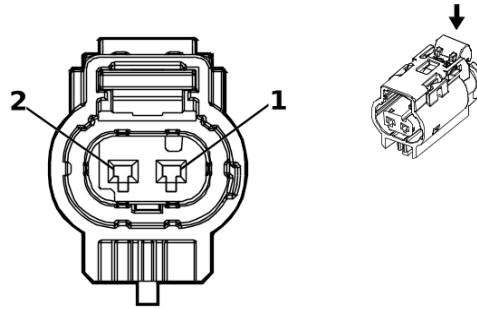

3747581

**Connector Part Information**

Harness Type: Engine Wiring Harness  
 OEM Connector: 10094234  
 Service Connector: 84727362  
 Description: 2-Way F 1.2 Multilock Series, Sealed( BK)

**Terminal Part Information**

Terminal Type ID	Terminated Lead	Diagnostic Test Probe	Terminal Removal Tool
I	Not required	J-35616-16 (L-GN)	No Tool Required

**B193A Charge Air Cooler Air Temperature Sensor - Inlet**

Pin	Size	Color	Circuit	Function	Terminal Type ID	Option
1	0.5	GN	3683	Charge Air Cooler Inlet Temperature Sensor Signal	I	—
2	0.5	YE / BK	3682	Charge Air Cooler Inlet Temperature Sensor Low Reference	I	—

**B193B Charge Air Cooler Air Temperature Sensor - Outlet**

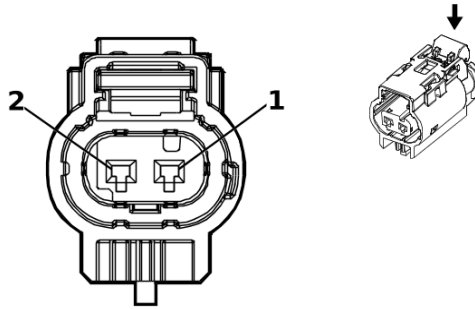

3747581

**Connector Part Information**

Harness Type: Engine Wiring Harness  
 OEM Connector: 10094234  
 Service Connector: 84727362  
 Description: 2-Way F 1.2 Multilock Series, Sealed( BK)

**Terminal Part Information**

Terminal Type ID	Terminated Lead	Diagnostic Test Probe	Terminal Removal Tool
I	Not required	J-35616-16 (L-GN)	No Tool Required

**B193B Charge Air Cooler Air Temperature Sensor - Outlet**

Pin	Size	Color	Circuit	Function	Terminal Type ID	Option
1	0.5	BN	3681	Charge Air Cooler Outlet Temperature Sensor Signal	I	—
2	0.5	YE / BU	3680	Charge Air Cooler Outlet Temperature Sensor Low Reference	I	—

## B195A Nitrogen Oxides Sensor 1

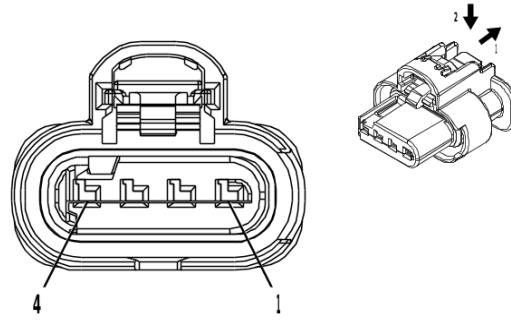

4210809

### Connector Part Information

Harness Type: Engine Wiring Harness  
 OEM Connector: 1-2296696-1  
 Service Connector: 85518225  
 Description: 4-Way F 1.2 MCON-CB Series, Sealed( BK)

### Terminal Part Information

Terminal Type ID	Terminated Lead	Diagnostic Test Probe	Terminal Removal Tool
I	Not required	J-35616-16 (L-GN)	No Tool Required

### B195A Nitrogen Oxides Sensor 1

Pin	Size	Color	Circuit	Function	Terminal Type ID	Option
1	1	VT / GN	4320	Powertrain Sensor Bus Enable	I	—
2	0.5	WH	4055	Private Serial Data Powertrain CAN Bus [+] Serial Data	I	—
3	0.5	BU / GY	4054	Private Serial Data Powertrain CAN Bus [-] Serial Data	I	—
4	1	BK / WH	1151	Signal Ground	I	—

**B195B Nitrogen Oxides Sensor 2 (LM2)**

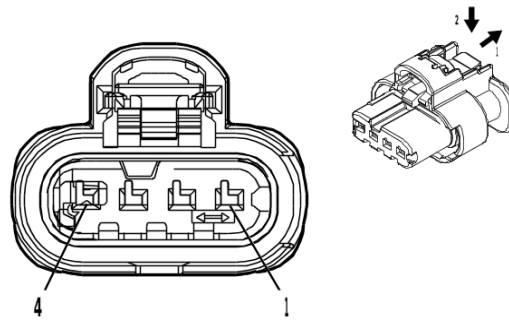

4934614

**Connector Part Information**

Harness Type: Chassis Wiring Harness  
 OEM Connector: 1-2296696-2  
 Service Connector: 85519071  
 Description: 4-Way F 1.2 MCON-CB Series, Sealed( BK)

**Terminal Part Information**

Terminal Type ID	Terminated Lead	Diagnostic Test Probe	Terminal Removal Tool
I	Not required	J-35616-16 (L-GN)	No Tool Required

**B195B Nitrogen Oxides Sensor 2 (LM2)**

Pin	Size	Color	Circuit	Function	Terminal Type ID	Option
1	1	VT / GN	4320	Powertrain Sensor Bus Enable	I	—
2	0.5	WH	4055	Private Serial Data Powertrain CAN Bus [+] Serial Data	I	—
3	0.5	BU / GY	4054	Private Serial Data Powertrain CAN Bus [-] Serial Data	I	—
4	1	BK / WH	1151	Signal Ground	I	—



**B195C Nitrogen Oxides Sensor 3 (LM2)**

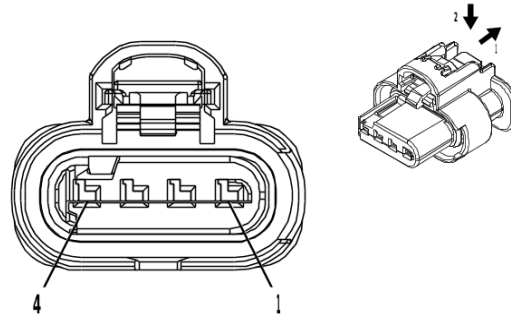

4210809

**Connector Part Information**

Harness Type: Chassis Wiring Harness  
 OEM Connector: 1-2296696-1  
 Service Connector: 85518225  
 Description: 4-Way F 1.2 MCON-CB Series, Sealed( BK)

**Terminal Part Information**

Terminal Type ID	Terminated Lead	Diagnostic Test Probe	Terminal Removal Tool
I	Not required	J-35616-16 (L-GN)	No Tool Required

**B195C Nitrogen Oxides Sensor 3 (LM2)**

Pin	Size	Color	Circuit	Function	Terminal Type ID	Option
1	1	VT / GN	4320	Powertrain Sensor Bus Enable	I	—
2	0.5	WH	4055	Private Serial Data Powertrain CAN Bus [+] Serial Data	I	—
3	0.5	BU / GY	4054	Private Serial Data Powertrain CAN Bus [-] Serial Data	I	—
4	1	BK / WH	1151	Signal Ground	I	—

**B198 Fuel Composition Sensor (FHS)**

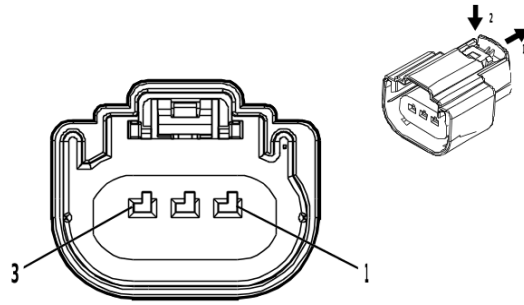

4829227

**Connector Part Information**

Harness Type: Chassis Wiring Harness  
 OEM Connector: 160073-3107  
 Service Connector: 19371197  
 Description: 3-Way F 1.5 MX Series, Sealed( GY)

**Terminal Part Information**

Terminal Type ID	Terminated Lead	Diagnostic Test Probe	Terminal Removal Tool
I	Not required	J-35616-14 (GN)	No Tool Required

**B198 Fuel Composition Sensor (FHS)**

Pin	Size	Color	Circuit	Function	Terminal Type ID	Option
1	0.5	VT / GN	4320	Powertrain Sensor Bus Enable	I	—
2	0.5	BK / GY	3802	Fuel Composition Sensor Low Reference	I	—
3	0.5	VT / BN	3803	Fuel Composition Sensor Signal	I	—

## B203 Radiator Coolant Temperature Sensor

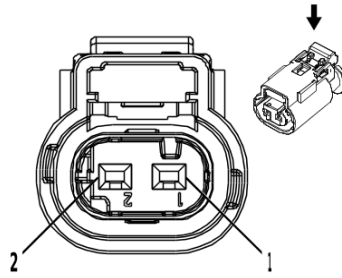

2717066

### Connector Part Information

Harness Type: Engine Wiring Harness  
 OEM Connector: 10010337  
 Service Connector: 13587326  
 Description: 2-Way F 1.2 Multilock Series, Sealed( BK)

### Terminal Part Information

Terminal Type ID	Terminated Lead	Diagnostic Test Probe	Terminal Removal Tool
I	Not required	J-35616-16 (L-GN)	No Tool Required

### B203 Radiator Coolant Temperature Sensor

Pin	Size	Color	Circuit	Function	Terminal Type ID	Option
1	0.5	YE / BK	3000	Coolant Temperature Sensor 2 Signal	I	—
2	0.5	BK / GN	580	Engine Control Sensors Low Reference 2	I	—

**B212 Reductant Tank Fluid Sensor (LZ0)**

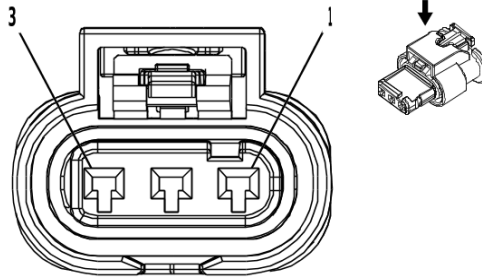

2750649

**Connector Part Information**

Harness Type: Emission Reduction Fluid Tank Reservoir Wire Harness  
 OEM Connector: 13722729  
 Service Connector: Service by Harness - See Part Catalog  
 Description: 3-Way F 1.2 MCON Series, Sealed( BK)

**Terminal Part Information**

Terminal Type ID	Terminated Lead	Diagnostic Test Probe	Terminal Removal Tool
I	Not required	J-35616-16 (L-GN)	No Tool Required

**B212 Reductant Tank Fluid Sensor (LZ0)**

Pin	Size	Color	Circuit	Function	Terminal Type ID	Option
1	0.5	BK	7290	Diesel Exhaust Fluid Sensor Voltage Reference 1	I	—
2	0.5	BN	7284	Diesel Exhaust Fluid Liquid Quality Temperature Signal	I	—
3	0.5	BK	8434	Diesel Exhaust Fluid Sensor Low Reference	I	—

**B218L Side Obstacle Detection Control Module - Left (UKC / UKV)**

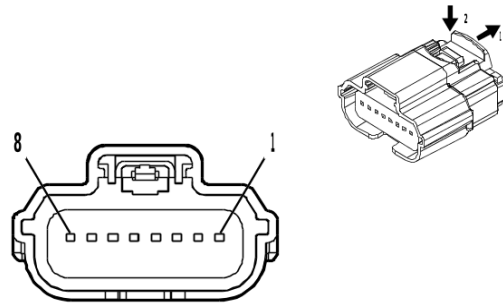

4708234

**Connector Part Information**

Harness Type: Rear Object Alarm Sensor Wiring Harness  
 OEM Connector: 31404-9110  
 Service Connector: Service by Harness - See Part Catalog  
 Description: 8-Way F 64 Series, Sealed( BK)

**Terminal Part Information**

Terminal Type ID	Terminated Lead	Diagnostic Test Probe	Terminal Removal Tool
I	Not required	J-35616-64B (L-BU)	No Tool Required

**B218L Side Obstacle Detection Control Module - Left (UKC / UKV)**

Pin	Size	Color	Circuit	Function	Terminal Type ID	Option
1	0.5	WH	4087	Private Serial Data Side Obstacle Detection CAN Bus [-] Serial Data	I	—
2	0.5	BU / VT	4088	Private Serial Data Side Obstacle Detection CAN Bus [+] Serial Data	I	—
3	0.5	BK / WH	1951	Signal Ground	I	—
4	0.5	WH	4100	AUTOSAR CAN Bus [-] 4 Serial Data	I	—
5	0.5	WH	4100	AUTOSAR CAN Bus [-] 4 Serial Data	I	—
6	0.5	BU / VT	4101	AUTOSAR CAN Bus [+] 4 Serial Data	I	—
7	0.5	BU / VT	4101	AUTOSAR CAN Bus [+] 4 Serial Data	I	—
8	0.5	RD / GN	6940	Battery Positive Voltage	I	—

**B218R Side Obstacle Detection Control Module - Right (UKC / UKV)**

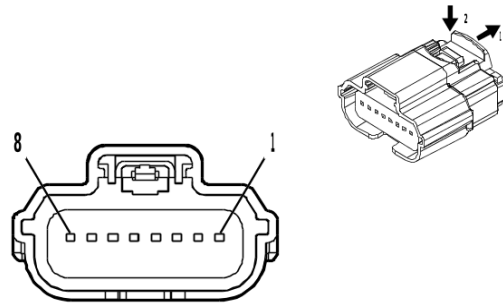

4708234

**Connector Part Information**

Harness Type: Rear Object Alarm Sensor Wiring Harness  
 OEM Connector: 31404-9532  
 Service Connector: Service by Harness - See Part Catalog  
 Description: 8-Way F 64 Series, Sealed( BK)

**Terminal Part Information**

Terminal Type ID	Terminated Lead	Diagnostic Test Probe	Terminal Removal Tool
I	Not required	J-35616-64B (L-BU)	No Tool Required

**B218R Side Obstacle Detection Control Module - Right (UKC / UKV)**

Pin	Size	Color	Circuit	Function	Terminal Type ID	Option
1	0.5	WH	4087	Private Serial Data Side Obstacle Detection CAN Bus [-] Serial Data	I	—
2	0.5	BU / VT	4088	Private Serial Data Side Obstacle Detection CAN Bus [+] Serial Data	I	—
3	0.5	BK / WH	1951	Signal Ground	I	—
4	—	—	—	Not Occupied	—	—
5	0.5	WH	4100	AUTOSAR CAN Bus [-] 4 Serial Data	I	—
6	0.5	BU / VT	4101	AUTOSAR CAN Bus [+] 4 Serial Data	I	—
7	—	—	—	Not Occupied	—	—
8	0.5	RD / GN	6940	Battery Positive Voltage	I	—

**B233B Forward Range Radar Sensor - Long Range (UKL / (UGN - UKL))**

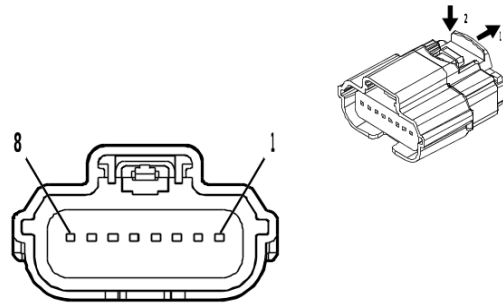

4708234

**Connector Part Information**

Harness Type: Front Object Alarm Sensor Wiring Harness  
 OEM Connector: 13526723  
 Service Connector: Service by Harness - See Part Catalog  
 Description: 8-Way F 64 Series, Sealed( BK)

**Terminal Part Information**

Terminal Type ID	Terminated Lead	Diagnostic Test Probe	Terminal Removal Tool
I	Not required	J-35616-64B (L-BU)	No Tool Required

**B233B Forward Range Radar Sensor - Long Range (UKL / (UGN - UKL))**

Pin	Size	Color	Circuit	Function	Terminal Type ID	Option
1 - 2	—	—	—	Not Occupied	—	—
3	0.5	BU / GY	4105	AUTOSAR CAN Bus [+] 8 Serial Data	I	—
4	0.5	WH / GY	4104	AUTOSAR CAN Bus [-] 8 Serial Data	I	—
5	0.5	RD / GN	3140	Battery Positive Voltage	I	—
6 - 7	—	—	—	Not Occupied	—	—
8	0.5	BK / WH	651	Signal Ground	I	—

**B233LF Short Range Radar Sensor - Left Front (UKL)**

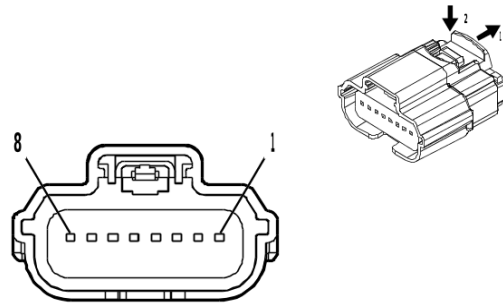

4708234

**Connector Part Information**

Harness Type: Front Object Alarm Sensor Wiring Harness  
 OEM Connector: 31404-9111  
 Service Connector: Service by Harness - See Part Catalog  
 Description: 8-Way F 64 Series, Sealed( BK)

**Terminal Part Information**

Terminal Type ID	Terminated Lead	Diagnostic Test Probe	Terminal Removal Tool
I	Not required	J-35616-64B (L-BU)	No Tool Required

**B233LF Short Range Radar Sensor - Left Front (UKL)**

Pin	Size	Color	Circuit	Function	Terminal Type ID	Option
1	0.5	BK / WH	651	Signal Ground	I	—
2	0.5	BK / WH	651	Signal Ground	I	—
3	—	—	—	Not Occupied	—	—
4	0.5	RD / GN	3140	Battery Positive Voltage	I	—
5	0.5	WH / GY	4104	AUTOSAR CAN Bus [-] 8 Serial Data	I	—
6	0.5	BU / GY	4105	AUTOSAR CAN Bus [+] 8 Serial Data	I	—
7	0.5	WH / GY	4104	AUTOSAR CAN Bus [-] 8 Serial Data	I	—
8	0.5	BU / GY	4105	AUTOSAR CAN Bus [+] 8 Serial Data	I	—



**B233LR Short Range Radar Rear Sensor - Left (UKL)**

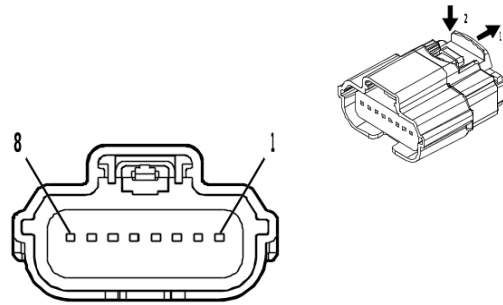

4708234

**Connector Part Information**

Harness Type: Rear Object Alarm Sensor Wiring Harness  
 OEM Connector: 31404-9552  
 Service Connector: Service by Harness - See Part Catalog  
 Description: 8-Way F 64 Series, Sealed( BK)

**Terminal Part Information**

Terminal Type ID	Terminated Lead	Diagnostic Test Probe	Terminal Removal Tool
I	Not required	J-35616-64B (L-BU)	No Tool Required

**B233LR Short Range Radar Rear Sensor - Left (UKL)**

Pin	Size	Color	Circuit	Function	Terminal Type ID	Option
1	0.5	BK / WH	1951	Signal Ground	I	—
2 - 3	—	—	—	Not Occupied	—	—
4	0.5	RD / BU	5240	Battery Positive Voltage	I	—
5	0.5	WH / GY	4104	AUTOSAR CAN Bus [-] 8 Serial Data	I	—
6	0.5	BU / GY	4105	AUTOSAR CAN Bus [+] 8 Serial Data	I	—
7	0.5	WH / GY	4104	AUTOSAR CAN Bus [-] 8 Serial Data	I	—
8	0.5	BU / GY	4105	AUTOSAR CAN Bus [+] 8 Serial Data	I	—

**B233RF Short Range Radar Sensor - Right Front**

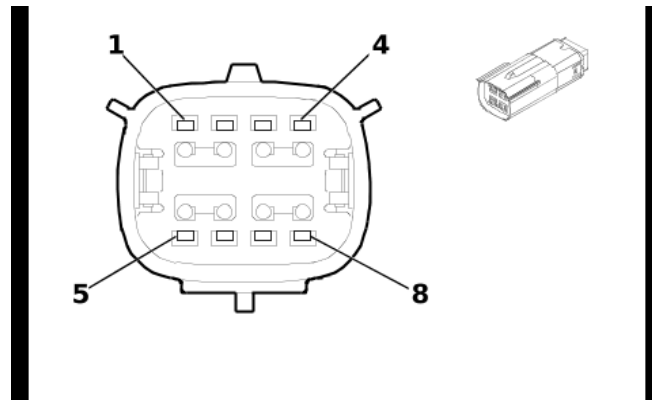

5402096

**Connector Part Information**

Harness Type: Front Object Alarm Sensor Wiring Harness - Jumper  
 OEM Connector: 15514651  
 Service Connector: Service by Harness - See Part Catalog  
 Description: 8-Way M 1.5 OCS Series, Sealed( BK)

**Terminal Part Information**

Terminal Type ID	Terminated Lead	Diagnostic Test Probe	Terminal Removal Tool
I	Not required	J-35616-3 (GY)	No Tool Required
II	Not required	No Tool Required	No Tool Required

**B233RF Short Range Radar Sensor - Right Front**

Pin	Size	Color	Circuit	Function	Terminal Type ID	Option
1	0.5	BK / WH	651	Signal Ground	I	—
2	0.5	BK / WH	651	Signal Ground	I	—
3	0.5	BK / WH	651	Signal Ground	I	—
4	0.5	RD / GN	3140	Battery Positive Voltage	I	—
5	0.5	WH / GY	4104	AUTOSAR CAN Bus [-] 8 Serial Data	I	—
6	—	BU / GY	4105	AUTOSAR CAN Bus [+] 8 Serial Data	II	—
7	0.5	WH / GY	4104	AUTOSAR CAN Bus [-] 8 Serial Data	I	—
8	0.5	BU / GY	4105	AUTOSAR CAN Bus [+] 8 Serial Data	I	—

**B233RR Short Range Radar Rear Sensor - Right (UKL)**

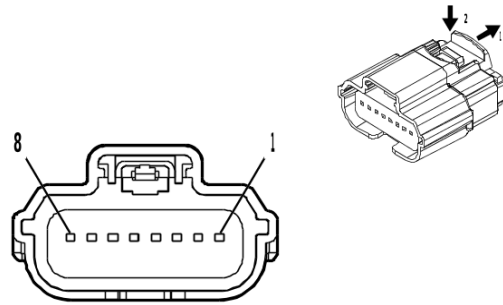

4708234

**Connector Part Information**

Harness Type: Rear Object Alarm Sensor Wiring Harness  
 OEM Connector: 31404-9110  
 Service Connector: Service by Harness - See Part Catalog  
 Description: 8-Way F 64 Series, Sealed( BK)

**Terminal Part Information**

Terminal Type ID	Terminated Lead	Diagnostic Test Probe	Terminal Removal Tool
I	Not required	J-35616-64B (L-BU)	No Tool Required

**B233RR Short Range Radar Rear Sensor - Right (UKL)**

Pin	Size	Color	Circuit	Function	Terminal Type ID	Option
1	0.5	BK / WH	1951	Signal Ground	I	—
2	0.5	BK / WH	1951	Signal Ground	I	—
3	0.5	BK / WH	1951	Signal Ground	I	—
4	0.5	RD / BU	5240	Battery Positive Voltage	I	—
5	0.5	WH / GY	4104	AUTOSAR CAN Bus [-] 8 Serial Data	I	—
6	0.5	BU / GY	4105	AUTOSAR CAN Bus [+] 8 Serial Data	I	—
7	0.5	WH / GY	4104	AUTOSAR CAN Bus [-] 8 Serial Data	I	—
8	0.5	BU / GY	4105	AUTOSAR CAN Bus [+] 8 Serial Data	I	—

**B233SL Short Range Radar Rear Side Sensor - Left (UKL)**

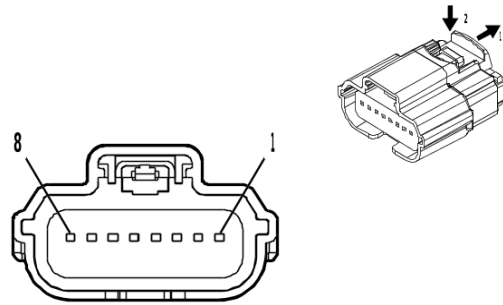

4708234

**Connector Part Information**

Harness Type: Rear Object Alarm Sensor Wiring Harness  
 OEM Connector: 31404-9552  
 Service Connector: Service by Harness - See Part Catalog  
 Description: 8-Way F 64 Series, Sealed( BK)

**Terminal Part Information**

Terminal Type ID	Terminated Lead	Diagnostic Test Probe	Terminal Removal Tool
I	Not required	J-35616-64B (L-BU)	No Tool Required

**B233SL Short Range Radar Rear Side Sensor - Left (UKL)**

Pin	Size	Color	Circuit	Function	Terminal Type ID	Option
1	0.5	BK / WH	1951	Signal Ground	I	—
2 - 3	—	—	—	Not Occupied	—	—
4	0.5	RD / BU	5240	Battery Positive Voltage	I	—
5	0.5	WH / GY	4104	AUTOSAR CAN Bus [-] 8 Serial Data	I	—
6	0.5	BU / GY	4105	AUTOSAR CAN Bus [+] 8 Serial Data	I	—
7	0.5	WH / GY	4104	AUTOSAR CAN Bus [-] 8 Serial Data	I	—
8	0.5	BU / GY	4105	AUTOSAR CAN Bus [+] 8 Serial Data	I	—

**B233SR Short Range Radar Rear Side Sensor - Right (UKL)**

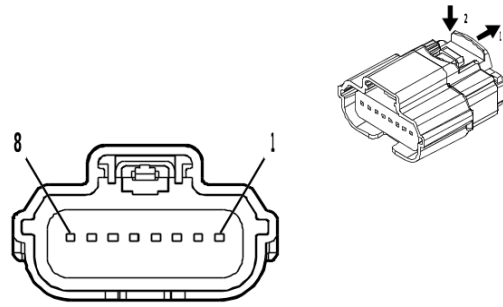

4708234

**Connector Part Information**

Harness Type: Rear Object Alarm Sensor Wiring Harness  
 OEM Connector: 31404-9110  
 Service Connector: Service by Harness - See Part Catalog  
 Description: 8-Way F 64 Series, Sealed( BK)

**Terminal Part Information**

Terminal Type ID	Terminated Lead	Diagnostic Test Probe	Terminal Removal Tool
I	Not required	J-35616-64B (L-BU)	No Tool Required

**B233SR Short Range Radar Rear Side Sensor - Right (UKL)**

Pin	Size	Color	Circuit	Function	Terminal Type ID	Option
1	0.5	BK / WH	1951	Signal Ground	I	—
2	0.5	BK / WH	1951	Signal Ground	I	—
3	0.5	BK / WH	1951	Signal Ground	I	—
4	0.5	RD / BU	5240	Battery Positive Voltage	I	—
5	0.5	WH / GY	4104	AUTOSAR CAN Bus [-] 8 Serial Data	I	—
6	0.5	BU / GY	4105	AUTOSAR CAN Bus [+] 8 Serial Data	I	—
7	0.5	WH / GY	4104	AUTOSAR CAN Bus [-] 8 Serial Data	I	—
8	0.5	BU / GY	4105	AUTOSAR CAN Bus [+] 8 Serial Data	I	—

**B280 Transmission Fluid Pressure Accumulator Solenoid Valve (MQE)**

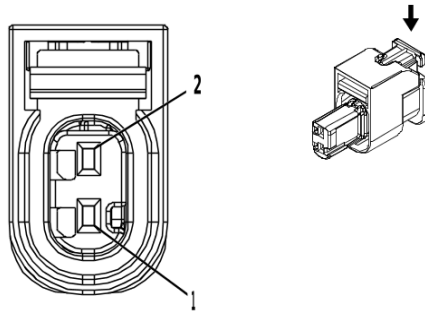

4051102

**Connector Part Information**

Harness Type: Automatic Transmission Wiring Harness - Case  
 OEM Connector: 2138873-4  
 Service Connector: Service by Harness - See Part Catalog  
 Description: 2-Way F 1.2 MCON Series, Sealed( BN)

**Terminal Part Information**

Terminal Type ID	Terminated Lead	Diagnostic Test Probe	Terminal Removal Tool
I	Not required	J-35616-12 (BU)	No Tool Required

**B280 Transmission Fluid Pressure Accumulator Solenoid Valve (MQE)**

Pin	Size	Color	Circuit	Function	Terminal Type ID	Option
1	0.5	YE / GN	6387	Transmission High Side Driver 1 Control	I	—
2	0.5	WH / GY	4578	Surge Accumulator Solenoid Valve Low Side Control	I	—

**B284 Vehicle Dynamics Sensor (UKL)**

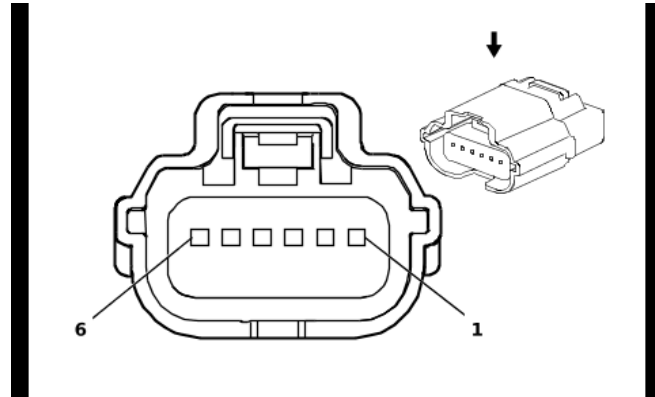

1974974

**Connector Part Information**

Harness Type: Body Wiring Harness  
 OEM Connector: 35473844  
 Service Connector: 84773558  
 Description: 6-Way F 0.64 Series, Sealed( BK)

**Terminal Part Information**

Terminal Type ID	Terminated Lead	Diagnostic Test Probe	Terminal Removal Tool
I	Not required	J-35616-64B (L-BU)	No Tool Required

**B284 Vehicle Dynamics Sensor (UKL)**

Pin	Size	Color	Circuit	Function	Terminal Type ID	Option
1	0.5	VT / GY	8978	Inertial Sensor Supply Voltage	I	—
2	0.5	BU / YE	8977	Private Serial Data Active Safety CAN Bus [+] Serial Data	I	—
3	0.5	WH / YE	8976	Private Serial Data Active Safety CAN Bus [-] Serial Data	I	—
4 - 5	—	—	—	Not Occupied	—	—
6	0.5	BK / WH	1551	Signal Ground	I	—

**B292 Driver Monitoring Camera (UKL)**

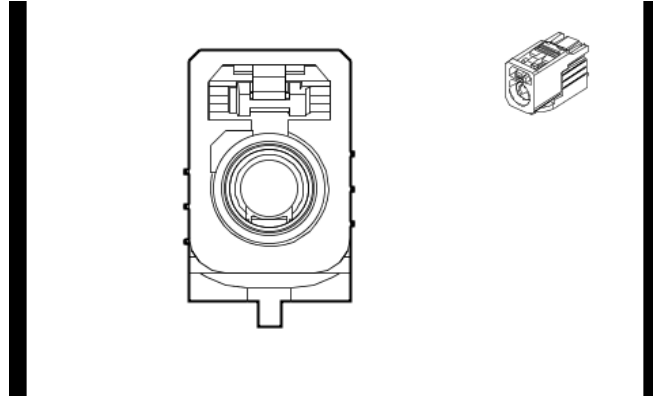

5633912

**Connector Part Information**

Harness Type: Instrument Panel Wiring Harness COAX  
 OEM Connector: 33351016  
 Service Connector: Service by Cable Assembly — See Part Catalog  
 Description: 1-Way F Coax Type( GN)

**Terminal Part Information**

Terminal Type ID	Terminated Lead	Diagnostic Test Probe	Terminal Removal Tool
I	Not required	No Tool Required	No Tool Required

**B292 Driver Monitoring Camera (UKL)**

Pin	Size	Color	Circuit	Function	Terminal Type ID	Option
—	—	Coax Cable	—	Driver Monitoring System Camera Coaxial Signal	I	—



**B306A Parking Assist Alarm Sensor - Front Left Outer (UD5)**

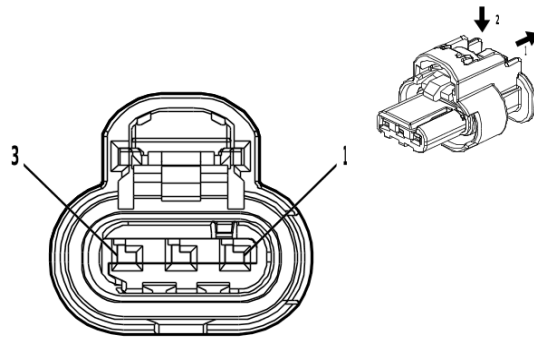

4581126

**Connector Part Information**

Harness Type: Front Object Alarm Sensor Wiring Harness  
 OEM Connector: 13514590  
 Service Connector: Service by Harness - See Part Catalog  
 Description: 3-Way F 1.2 MCON-CB Series, Sealed( BK)

**Terminal Part Information**

Terminal Type ID	Terminated Lead	Diagnostic Test Probe	Terminal Removal Tool
I	Not required	J-35616-16 (L-GN)	No Tool Required

**B306A Parking Assist Alarm Sensor - Front Left Outer (UD5)**

Pin	Size	Color	Circuit	Function	Terminal Type ID	Option
1	0.5	BN	6581	Front Parking Assist Display Control	I	—
2	0.5	VT / WH	5215	Left Front Outer Parking Assist Sensor	I	—
3	0.5	BK / BU	5214	Front Parking Assist Sensor Low Reference	I	—

**B306B Parking Assist Alarm Sensor - Front Left Middle (UD5)**

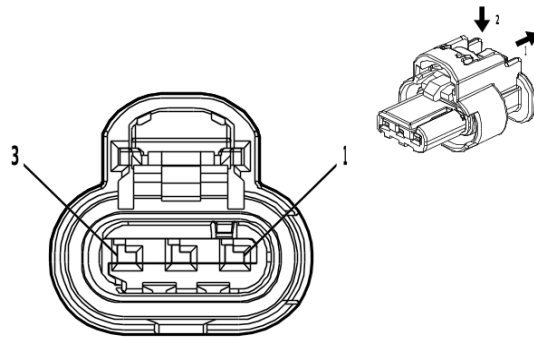

4581126

**Connector Part Information**

Harness Type: Front Object Alarm Sensor Wiring Harness  
 OEM Connector: 13514590  
 Service Connector: Service by Harness - See Part Catalog  
 Description: 3-Way F 1.2 MCON-CB Series, Sealed( BK)

**Terminal Part Information**

Terminal Type ID	Terminated Lead	Diagnostic Test Probe	Terminal Removal Tool
I	Not required	J-35616-16 (L-GN)	No Tool Required

**B306B Parking Assist Alarm Sensor - Front Left Middle (UD5)**

Pin	Size	Color	Circuit	Function	Terminal Type ID	Option
1	0.5	BN	6581	Front Parking Assist Display Control	I	—
2	0.5	YE / GY	5216	Left Front Middle Parking Assist Sensor	I	—
3	0.5	BK / BU	5214	Front Parking Assist Sensor Low Reference	I	—

**B306C Parking Assist Alarm Sensor - Front Right Middle (UD5)**

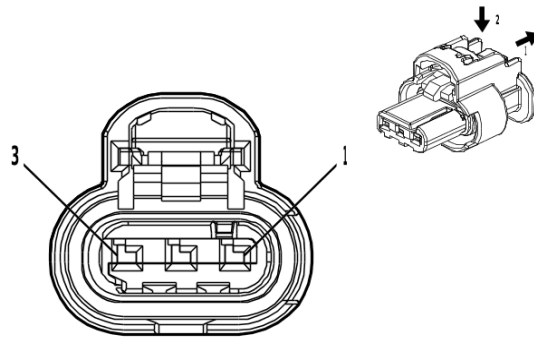

4581126

**Connector Part Information**

Harness Type: Front Object Alarm Sensor Wiring Harness  
 OEM Connector: 13514590  
 Service Connector: Service by Harness - See Part Catalog  
 Description: 3-Way F 1.2 MCON-CB Series, Sealed( BK)

**Terminal Part Information**

Terminal Type ID	Terminated Lead	Diagnostic Test Probe	Terminal Removal Tool
I	Not required	J-35616-16 (L-GN)	No Tool Required

**B306C Parking Assist Alarm Sensor - Front Right Middle (UD5)**

Pin	Size	Color	Circuit	Function	Terminal Type ID	Option
1	0.5	BN	6581	Front Parking Assist Display Control	I	—
2	0.5	VT / GY	5218	Right Front Middle Parking Assist Sensor	I	—
3	0.5	BK / BU	5214	Front Parking Assist Sensor Low Reference	I	—

**B306D Parking Assist Alarm Sensor - Front Right Outer (UD5)**

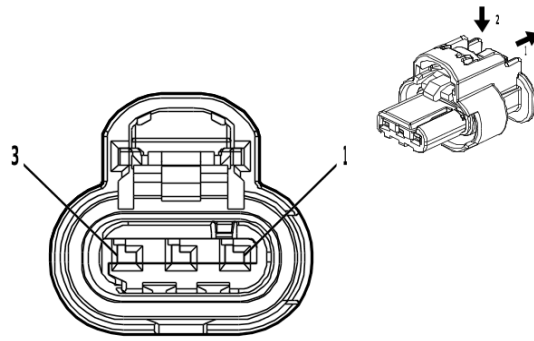

4581126

**Connector Part Information**

Harness Type: Front Object Alarm Sensor Wiring Harness  
 OEM Connector: 13514590  
 Service Connector: Service by Harness - See Part Catalog  
 Description: 3-Way F 1.2 MCON-CB Series, Sealed( BK)

**Terminal Part Information**

Terminal Type ID	Terminated Lead	Diagnostic Test Probe	Terminal Removal Tool
I	Not required	J-35616-16 (L-GN)	No Tool Required

**B306D Parking Assist Alarm Sensor - Front Right Outer (UD5)**

Pin	Size	Color	Circuit	Function	Terminal Type ID	Option
1	0.5	BN	6581	Front Parking Assist Display Control	I	—
2	0.5	WH / GY	5217	Right Front Outer Parking Assist Sensor	I	—
3	0.5	BK / BU	5214	Front Parking Assist Sensor Low Reference	I	—

**B306E Parking Assist Alarm Sensor - Rear Left Outer (UD5 / UD7)**

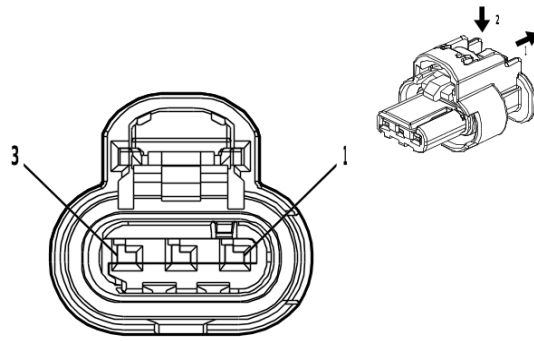

4581126

**Connector Part Information**

Harness Type: Rear Object Alarm Sensor Wiring Harness  
 OEM Connector: 1-2296695-1  
 Service Connector: Service by Harness - See Part Catalog  
 Description: 3-Way F 1.2 MCON-CB Series, Sealed( BK)

**Terminal Part Information**

Terminal Type ID	Terminated Lead	Diagnostic Test Probe	Terminal Removal Tool
I	Not required	J-35616-16 (L-GN)	No Tool Required

**B306E Parking Assist Alarm Sensor - Rear Left Outer (UD5 / UD7)**

Pin	Size	Color	Circuit	Function	Terminal Type ID	Option
1	0.5	BN / WH	2374	Object Sensor Voltage Reference	I	—
2	0.5	YE	2375	Left Rear Outer Parking Assist Sensor Signal	I	—
3	0.5	BK / GY	2379	Object Sensor Low Reference	I	—

**B306F Parking Assist Alarm Sensor - Rear Left Middle (UD5 / UD7)**

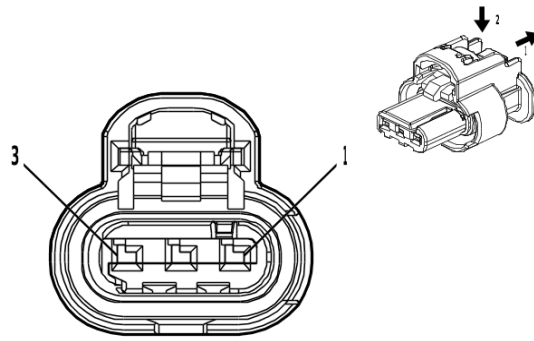

4581126

**Connector Part Information**

Harness Type: Rear Object Alarm Sensor Wiring Harness  
 OEM Connector: 1-2296695-1  
 Service Connector: Service by Harness - See Part Catalog  
 Description: 3-Way F 1.2 MCON-CB Series, Sealed( BK)

**Terminal Part Information**

Terminal Type ID	Terminated Lead	Diagnostic Test Probe	Terminal Removal Tool
I	Not required	J-35616-16 (L-GN)	No Tool Required

**B306F Parking Assist Alarm Sensor - Rear Left Middle (UD5 / UD7)**

Pin	Size	Color	Circuit	Function	Terminal Type ID	Option
1	0.5	BN / WH	2374	Object Sensor Voltage Reference	I	—
2	0.5	YE / BU	2376	Left Rear Middle Parking Assist Sensor Signal	I	—
3	0.5	BK / GY	2379	Object Sensor Low Reference	I	—

**B306G Parking Assist Alarm Sensor - Rear Right Middle (UD5 / UD7)**

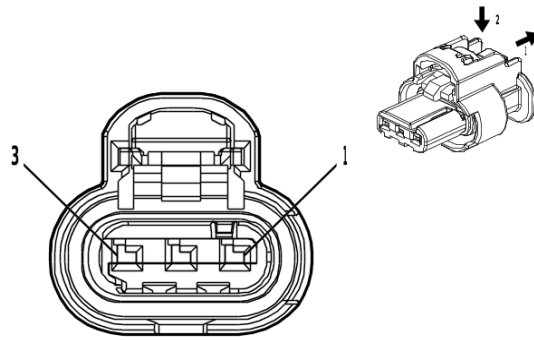

4581126

**Connector Part Information**

Harness Type: Rear Object Alarm Sensor Wiring Harness  
 OEM Connector: 1-2296695-1  
 Service Connector: Service by Harness - See Part Catalog  
 Description: 3-Way F 1.2 MCON-CB Series, Sealed( BK)

**Terminal Part Information**

Terminal Type ID	Terminated Lead	Diagnostic Test Probe	Terminal Removal Tool
I	Not required	J-35616-16 (L-GN)	No Tool Required

**B306G Parking Assist Alarm Sensor - Rear Right Middle (UD5 / UD7)**

Pin	Size	Color	Circuit	Function	Terminal Type ID	Option
1	0.5	BN / WH	2374	Object Sensor Voltage Reference	I	—
2	0.5	YE / WH	2377	Right Rear Middle Parking Assist Sensor Signal	I	—
3	0.5	BK / GY	2379	Object Sensor Low Reference	I	—

**B306H Parking Assist Alarm Sensor - Rear Right Outer (UD5 / UD7)**

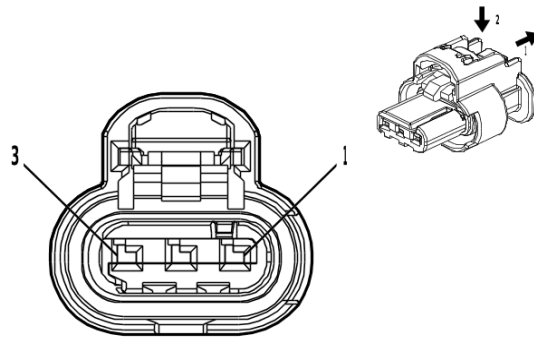

4581126

**Connector Part Information**

Harness Type: Rear Object Alarm Sensor Wiring Harness  
 OEM Connector: 1-2296695-1  
 Service Connector: Service by Harness - See Part Catalog  
 Description: 3-Way F 1.2 MCON-CB Series, Sealed( BK)

**Terminal Part Information**

Terminal Type ID	Terminated Lead	Diagnostic Test Probe	Terminal Removal Tool
I	Not required	J-35616-16 (L-GN)	No Tool Required

**B306H Parking Assist Alarm Sensor - Rear Right Outer (UD5 / UD7)**

Pin	Size	Color	Circuit	Function	Terminal Type ID	Option
1	0.5	BN / WH	2374	Object Sensor Voltage Reference	I	—
2	0.5	YE / VT	2378	Right Rear Outer Parking Assist Sensor Signal	I	—
3	0.5	BK / GY	2379	Object Sensor Low Reference	I	—



**B315A Transmission Range Control Valve 1 Position Switch (MHS / MQC)**

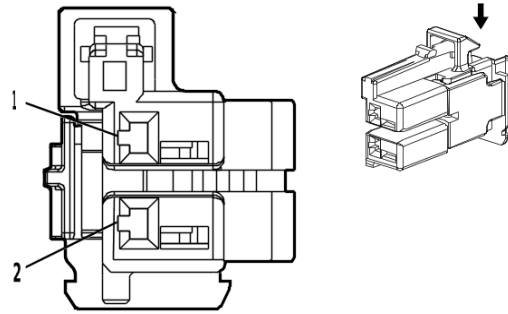

4672650

**Connector Part Information**

Harness Type: Automatic Transmission Wiring Harness - Control Extension  
 OEM Connector: 2289523-1  
 Service Connector: Service by Harness - See Part Catalog  
 Description: 2-Way F 1.2 MCON Series( BN)

**Terminal Part Information**

Terminal Type ID	Terminated Lead	Diagnostic Test Probe	Terminal Removal Tool
I	Not required	J-35616-12 (BU)	No Tool Required

**B315A Transmission Range Control Valve 1 Position Switch (MHS / MQC)**

Pin	Size	Color	Circuit	Function	Terminal Type ID	Option
1	0.5	BU	4171	Transmission Input Shaft Speed Sensor Circuit 9V Reference	I	—
2	0.5	BK / GY	3706	Electronic Transmission Range Select Switch Analog Signal 1	I	—

**B316 Transmission Park Valve Position Switch (MHS / MQC)**

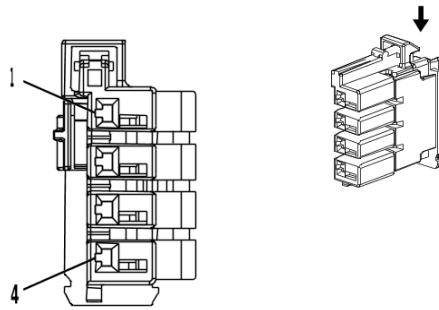

4364148

**Connector Part Information**

Harness Type: Automatic Transmission Wiring Harness - Control  
 OEM Connector: 2289524-1  
 Service Connector: Service by Harness - See Part Catalog  
 Description: 4-Way F 1.2 MCON Series( BN)

**Terminal Part Information**

Terminal Type ID	Terminated Lead	Diagnostic Test Probe	Terminal Removal Tool
I	Not required	J-35616-12 (BU)	No Tool Required

**B316 Transmission Park Valve Position Switch (MHS / MQC)**

Pin	Size	Color	Circuit	Function	Terminal Type ID	Option
1	—	—	—	Not Occupied	—	—
2	0.5	GN	4170	Transmission Output Shaft Speed Sensor Circuit 9V Reference	I	—
3	0.5	YE	6317	Electronic Transmission Range Select Out of Park Switch Signal	I	—
4	0.5	YE / GY	6319	Electronic Transmission Range Select Out of Park Switch 2 Signal	I	—

### B321 Crankcase Pressure Sensor (L3B)

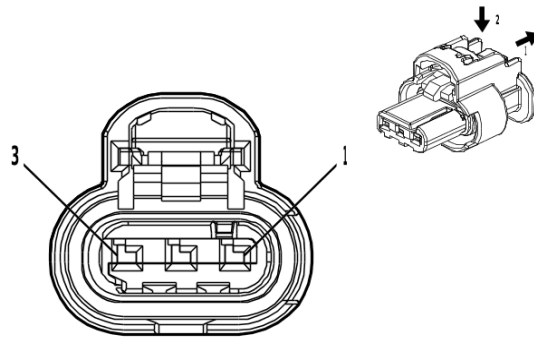

4581126

#### Connector Part Information

Harness Type: Engine Wiring Harness  
 OEM Connector: 1-2296695-1  
 Service Connector: 86792094  
 Description: 3-Way F 1.2 MCON-CB Series, Sealed( BK)

#### Terminal Part Information

Terminal Type ID	Terminated Lead	Diagnostic Test Probe	Terminal Removal Tool
I	Not required	J-35616-16 (L-GN)	No Tool Required

#### B321 Crankcase Pressure Sensor (L3B)

Pin	Size	Color	Circuit	Function	Terminal Type ID	Option
1	0.5	YE / GY	3926	Crankcase Differential Pressure Sensor Signal	I	—
2	0.5	BK / YE	548	Engine Control Sensors Low Reference 1	I	—
3	0.5	BU / RD	460	Engine Control Sensors 5 Volt Reference 1	I	—

**B321 Crankcase Pressure Sensor (LZ0)**

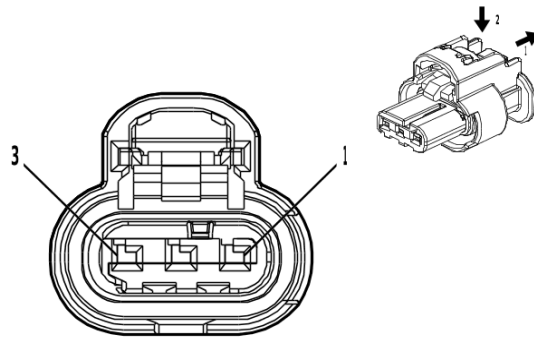

4778903

**Connector Part Information**

Harness Type: Engine Wiring Harness  
 OEM Connector: 1-2296695-2  
 Service Connector: 86792095  
 Description: 3-Way F 1.2 MCON-CB Series, Sealed( BK)

**Terminal Part Information**

Terminal Type ID	Terminated Lead	Diagnostic Test Probe	Terminal Removal Tool
I	Not required	J-35616-16 (L-GN)	No Tool Required

**B321 Crankcase Pressure Sensor (LZ0)**

Pin	Size	Color	Circuit	Function	Terminal Type ID	Option
1	0.5	BU / RD	460	Engine Control Sensors 5 Volt Reference 1	I	—
2	0.5	YE / GY	3926	Crankcase Differential Pressure Sensor Signal	I	—
3	0.5	BK / YE	548	Engine Control Sensors Low Reference 1	I	—

**B338A Intake Camshaft Profile Sleeve Position Sensor 1**

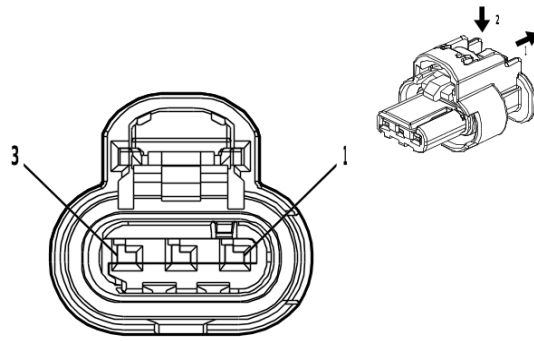

4581126

**Connector Part Information**

Harness Type: Engine Wiring Harness  
 OEM Connector: 1-2296695-1  
 Service Connector: 86792094  
 Description: 3-Way F 1.2 MCON-CB Series, Sealed( BK)

**Terminal Part Information**

Terminal Type ID	Terminated Lead	Diagnostic Test Probe	Terminal Removal Tool
I	Not required	J-35616-16 (L-GN)	No Tool Required

**B338A Intake Camshaft Profile Sleeve Position Sensor 1**

Pin	Size	Color	Circuit	Function	Terminal Type ID	Option
1	0.5	WH / RD	480	Engine Control Vehicle Sensors 5 Volt Reference 1	I	—
2	0.5	BK / GN	580	Engine Control Sensors Low Reference 2	I	—
3	0.5	VT / WH	3744	Camshaft Intake Lobe Axial Position Signal 1	I	—

**B338B Intake Camshaft Profile Sleeve Position Sensor 2**

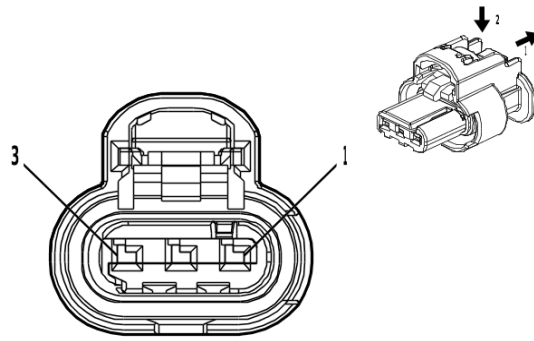

4581126

**Connector Part Information**

Harness Type: Engine Wiring Harness  
 OEM Connector: 1-2296695-1  
 Service Connector: 86792094  
 Description: 3-Way F 1.2 MCON-CB Series, Sealed( BK)

**Terminal Part Information**

Terminal Type ID	Terminated Lead	Diagnostic Test Probe	Terminal Removal Tool
I	Not required	J-35616-16 (L-GN)	No Tool Required

**B338B Intake Camshaft Profile Sleeve Position Sensor 2**

Pin	Size	Color	Circuit	Function	Terminal Type ID	Option
1	0.5	WH / RD	480	Engine Control Vehicle Sensors 5 Volt Reference 1	I	—
2	0.5	BK / GN	580	Engine Control Sensors Low Reference 2	I	—
3	0.5	VT / GN	3745	Camshaft Intake Lobe Axial Position Signal 2	I	—

**B345P Exhaust Pressure Differential Sensor - Particulate Filter**

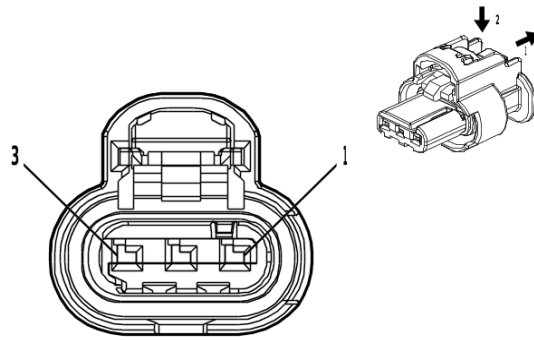

4581126

**Connector Part Information**

Harness Type: Engine Wiring Harness  
 OEM Connector: 1-2296695-1  
 Service Connector: 86792094  
 Description: 3-Way F 1.2 MCON-CB Series, Sealed( BK)

**Terminal Part Information**

Terminal Type ID	Terminated Lead	Diagnostic Test Probe	Terminal Removal Tool
I	Not required	J-35616-16 (L-GN)	No Tool Required

**B345P Exhaust Pressure Differential Sensor - Particulate Filter**

Pin	Size	Color	Circuit	Function	Terminal Type ID	Option
1	0.5	BU / RD	460	Engine Control Sensors 5 Volt Reference 1	I	—
2	0.5	WH / BN	2363	Exhaust Pressure Sensor SENT 1 Signal	I	—
3	0.5	BK / YE	548	Engine Control Sensors Low Reference 1	I	—

**B345R Exhaust Pressure Differential Sensor - Exhaust Gas Recirculation**

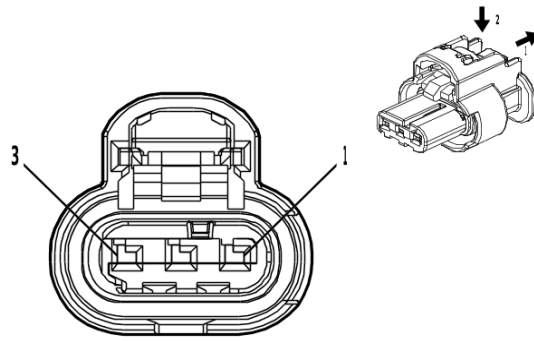

4778903

**Connector Part Information**

Harness Type: Engine Wiring Harness  
 OEM Connector: 1-2296695-2  
 Service Connector: 86792095  
 Description: 3-Way F 1.2 MCON-CB Series, Sealed( BK)

**Terminal Part Information**

Terminal Type ID	Terminated Lead	Diagnostic Test Probe	Terminal Removal Tool
I	Not required	J-35616-16 (L-GN)	No Tool Required

**B345R Exhaust Pressure Differential Sensor - Exhaust Gas Recirculation**

Pin	Size	Color	Circuit	Function	Terminal Type ID	Option
1	0.5	BU / RD	460	Engine Control Sensors 5 Volt Reference 1	I	—
2	0.5	GN	10478	Low Pressure Exhaust Gas Recirculation Sensor SENT Signal	I	—
3	0.5	BK / YE	548	Engine Control Sensors Low Reference 1	I	—



**B352 Video Display Inside Rearview Mirror Camera (DRZ)**

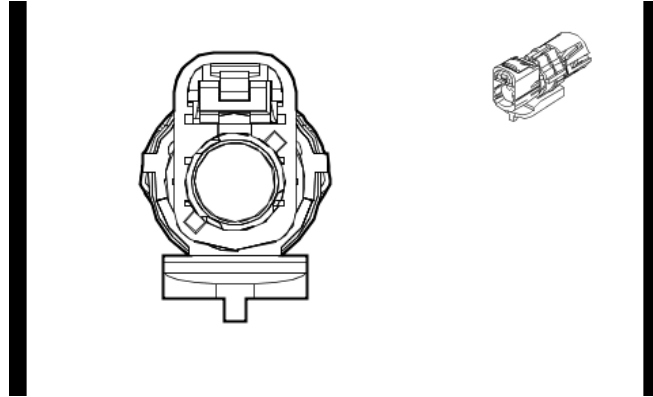

5633894

**Connector Part Information**

Harness Type: Inside Rearview Mirror Wiring Harness - Jumper COAX  
 OEM Connector: 35187049  
 Service Connector: Service by Cable Assembly — See Part Catalog  
 Description: 1-Way F Coax Type, Sealed( BU)

**Terminal Part Information**

Terminal Type ID	Terminated Lead	Diagnostic Test Probe	Terminal Removal Tool
I	Not required	No Tool Required	No Tool Required

**B352 Video Display Inside Rearview Mirror Camera (DRZ)**

Pin	Size	Color	Circuit	Function	Terminal Type ID	Option
—	—	Coax Cable	—	Full Display Mirror Rear Camera Coaxial Video Signal	I	—

**B359 Exhaust Gas Temperature Sensor Module**

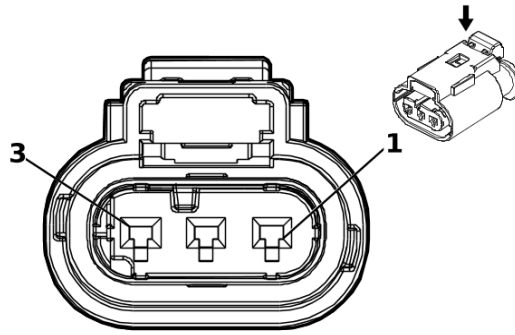

5192187

**Connector Part Information**

Harness Type: Engine Wiring Harness  
 OEM Connector: 10010343  
 Service Connector: 84777453  
 Description: 3-Way F 1.2 Multilock Series, Sealed( BK)

**Terminal Part Information**

Terminal Type ID	Terminated Lead	Diagnostic Test Probe	Terminal Removal Tool
I	Not required	J-35616-16 (L-GN)	No Tool Required

**B359 Exhaust Gas Temperature Sensor Module**

Pin	Size	Color	Circuit	Function	Terminal Type ID	Option
1	0.5	GN	10289	Exhaust Gas Temperature Sensor SENT 1 Signal	I	—
2	0.5	BK / GN	580	Engine Control Sensors Low Reference 2	I	—
3	0.5	WH / RD	480	Engine Control Vehicle Sensors 5 Volt Reference 1	I	—

## B359B Exhaust Gas Temperature Sensor Module 2

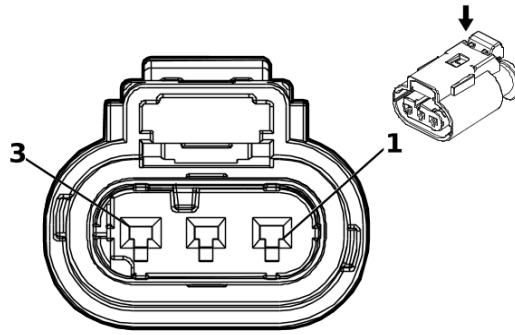

5192187

### Connector Part Information

Harness Type: Engine Wiring Harness  
 OEM Connector: 10010343  
 Service Connector: 84777453  
 Description: 3-Way F 1.2 Multilock Series, Sealed( BK)

### Terminal Part Information

Terminal Type ID	Terminated Lead	Diagnostic Test Probe	Terminal Removal Tool
I	Not required	J-35616-16 (L-GN)	No Tool Required

### B359B Exhaust Gas Temperature Sensor Module 2

Pin	Size	Color	Circuit	Function	Terminal Type ID	Option
1	0.5	BU	10290	Exhaust Gas Temperature Sensor SENT 2 Signal	I	—
2	0.5	BK / GN	580	Engine Control Sensors Low Reference 2	I	—
3	0.5	WH / RD	480	Engine Control Vehicle Sensors 5 Volt Reference 1	I	—

**E2LRB Side Marker Bulb - Left Rear**

**Connector Part Information**

Harness Type: Tail Lamp Wiring Harness - Left  
 OEM Connector: EEM0098-LGY  
 Service Connector: Service by Harness - See Part Catalog  
 Description: Bulb Socket

**Terminal Part Information**

Terminal Type ID	Terminated Lead	Diagnostic Test Probe	Terminal Removal Tool
I	Not required	J-35616-3 (GY)	No Tool Required

**E2LRB Side Marker Bulb - Left Rear**

Pin	Size	Color	Circuit	Function	Terminal Type ID	Option
1	0.75	BN	6993	Left Rear Park Lamp Control	I	—
	0.75	BN / BN	6993	Left Rear Park Lamp Control		—
2	0.75	BK	1951	Signal Ground	I	—
	0.75	BK	1951	Signal Ground		—

## E2RRB Side Marker Bulb - Right Rear

### Connector Part Information

Harness Type: Tail Lamp Wiring Harness - Right  
 OEM Connector: EEM0098-LGY  
 Service Connector: Service by Harness - See Part Catalog  
 Description: Bulb Socket

### Terminal Part Information

Terminal Type ID	Terminated Lead	Diagnostic Test Probe	Terminal Removal Tool
I	Not required	J-35616-3 (GY)	No Tool Required

### E2RRB Side Marker Bulb - Right Rear

Pin	Size	Color	Circuit	Function	Terminal Type ID	Option
1	0.75	BN	6995	Right Rear Park Lamp Control	I	—
	0.75	BN	6995	Right Rear Park Lamp Control		—
2	0.75	BK	1850	Ground	I	—
	0.75	BK / BK	1850	Ground		—

**E5A Backup Bulb - Left**

**Connector Part Information**

Harness Type: Tail Lamp Wiring Harness - Left  
 OEM Connector: EEM0323-BLK  
 Service Connector: Service by Harness - See Part Catalog  
 Description: Bulb Socket

**Terminal Part Information**

Terminal Type ID	Terminated Lead	Diagnostic Test Probe	Terminal Removal Tool
I	Not required	J-35616-3 (GY)	No Tool Required

**E5A Backup Bulb - Left**

Pin	Size	Color	Circuit	Function	Terminal Type ID	Option
1	0.75	GN	24	Backup Lamp Control	I	—
2	0.75 0.75	BK / BK BK	1951 1951	Signal Ground Signal Ground	I	— GF2/ GF3/ GF5/ GG0/ GPZ

## E5B Backup Bulb - Right

### Connector Part Information

Harness Type: Tail Lamp Wiring Harness - Right  
 OEM Connector: EEM0323-BLK  
 Service Connector: Service by Harness - See Part Catalog  
 Description: Bulb Socket

### Terminal Part Information

Terminal Type ID	Terminated Lead	Diagnostic Test Probe	Terminal Removal Tool
I	Not required	J-35616-3 (GY)	No Tool Required

### E5B Backup Bulb - Right

Pin	Size	Color	Circuit	Function	Terminal Type ID	Option
1	0.75	GN	24	Backup Lamp Control	I	—
2	0.75 0.75	BK BK	1850 1850	Ground Ground	I	— GF2/ GF3/ GF5/ GG0/ GPZ

**E6A High Mount Stop and Cargo Lamp**

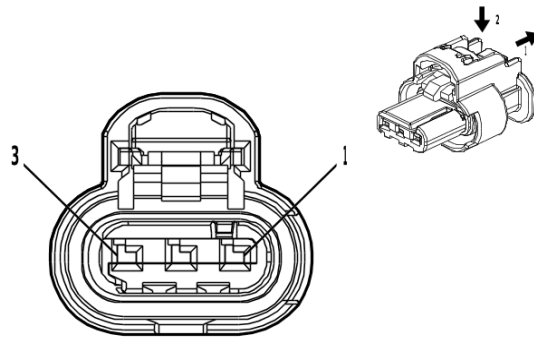

4581126

**Connector Part Information**

Harness Type: Inside Rearview Mirror Wiring Harness - Jumper  
 OEM Connector: 1-2296695-1  
 Service Connector: Service by Harness - See Part Catalog  
 Description: 3-Way F 1.2 MCON-CB Series, Sealed( BK)

**Terminal Part Information**

Terminal Type ID	Terminated Lead	Diagnostic Test Probe	Terminal Removal Tool
I	Not required	J-35616-12 (BU)	No Tool Required

**E6A High Mount Stop and Cargo Lamp**

Pin	Size	Color	Circuit	Function	Terminal Type ID	Option
1	0.5	WH / VT	1430	Exterior Courtesy Lamp Control	I	—
2	0.5	BN / YE	820	Center High Mounted Stop Lamp Supply Voltage	I	—
3	0.5	BK	1050	Ground	I	—



**E6B High Mount Stop Lamp Bulb - Regular Cab**

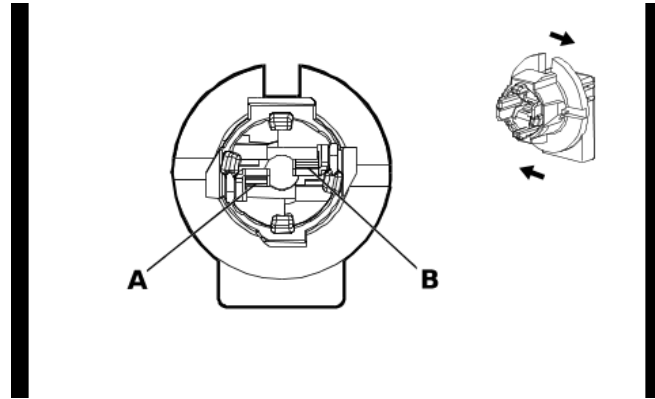

5913172

**Connector Part Information**

Harness Type: High Mount Stop Lamp Wiring Harness  
 OEM Connector: ZCF-02075-01  
 Service Connector: Service by Harness - See Part Catalog  
 Description: 2-Way F Socket( GY)

**Terminal Part Information**

Terminal Type ID	Terminated Lead	Diagnostic Test Probe	Terminal Removal Tool
I	Not required	Not Available	No Tool Required

**E6B High Mount Stop Lamp Bulb - Regular Cab**

Pin	Size	Color	Circuit	Function	Terminal Type ID	Option
A	0.75	RD	1053	Center High Mounted Stop Lamp Control 3	I	—
B	0.75	BK	1050	Ground	I	—

**E7L Rear License Plate Lamp - Left**

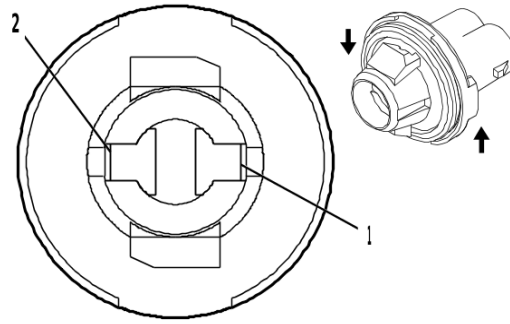

5153536

**Connector Part Information**

Harness Type: Rear Object Alarm Sensor Wiring Harness  
 OEM Connector: 15324946  
 Service Connector: Service by Harness - See Part Catalog  
 Description: 2-Way F Lamp Socket Wedge Base, Type W-2( D-GY)

**Terminal Part Information**

Terminal Type ID	Terminated Lead	Diagnostic Test Probe	Terminal Removal Tool
I	Not required	No Tool Required	No Tool Required

**E7L Rear License Plate Lamp - Left**

Pin	Size	Color	Circuit	Function	Terminal Type ID	Option
1	0.5	GN / YE	6846	Rear License Plate Lamp Control	I	—
2	0.5	BK	1850	Ground	I	—

## E7R Rear License Plate Lamp - Right

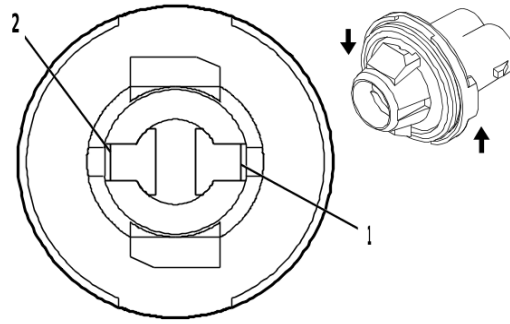

5153536

### Connector Part Information

Harness Type: Rear Object Alarm Sensor Wiring Harness  
 OEM Connector: 15324946  
 Service Connector: Service by Harness - See Part Catalog  
 Description: 2-Way F Lamp Socket Wedge Base, Type W-2( D-GY)

### Terminal Part Information

Terminal Type ID	Terminated Lead	Diagnostic Test Probe	Terminal Removal Tool
I	Not required	No Tool Required	No Tool Required

### E7R Rear License Plate Lamp - Right

Pin	Size	Color	Circuit	Function	Terminal Type ID	Option
1	0.5	GN / YE	6846	Rear License Plate Lamp Control	I	—
2	0.5	BK	1850	Ground	I	—

**E12A Glow Plug 1**

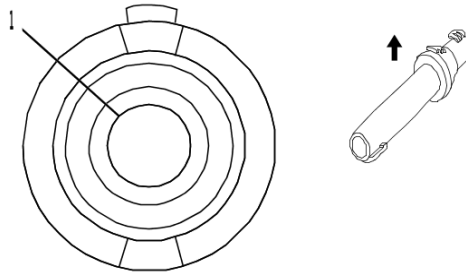

2231591

**Connector Part Information**

Harness Type: Diesel Glow Plug Wiring Harness  
 OEM Connector: 55571433  
 Service Connector: Service by Harness - See Part Catalog  
 Description: 1-Way F 4.0 Series( BK)

**Terminal Part Information**

Terminal Type ID	Terminated Lead	Diagnostic Test Probe	Terminal Removal Tool
I	Not required	J-35616-37 (L-BU)	No Tool Required

**E12A Glow Plug 1**

Pin	Size	Color	Circuit	Function	Terminal Type ID	Option
1	2.5	GY / RD	1581	Glow Plug 1 Control	I	—

## E12B Glow Plug 2

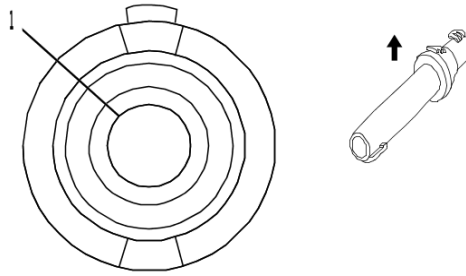

2231591

### Connector Part Information

Harness Type: Diesel Glow Plug Wiring Harness  
 OEM Connector: 55571433  
 Service Connector: Service by Harness - See Part Catalog  
 Description: 1-Way F 4.0 Series( BK)

### Terminal Part Information

Terminal Type ID	Terminated Lead	Diagnostic Test Probe	Terminal Removal Tool
I	Not required	J-35616-37 (L-BU)	No Tool Required

### E12B Glow Plug 2

Pin	Size	Color	Circuit	Function	Terminal Type ID	Option
1	2.5	GY / BK	1582	Glow Plug 2 Control	I	—

**E12C Glow Plug 3**

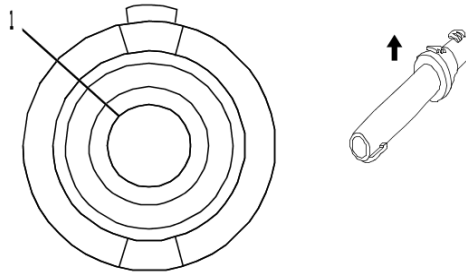

2231591

**Connector Part Information**

Harness Type: Diesel Glow Plug Wiring Harness  
 OEM Connector: 55571433  
 Service Connector: Service by Harness - See Part Catalog  
 Description: 1-Way F 4.0 Series( BK)

**Terminal Part Information**

Terminal Type ID	Terminated Lead	Diagnostic Test Probe	Terminal Removal Tool
I	Not required	J-35616-37 (L-BU)	No Tool Required

**E12C Glow Plug 3**

Pin	Size	Color	Circuit	Function	Terminal Type ID	Option
1	2.5	GY / GN	1583	Glow Plug 3 Control	I	—

## E12D Glow Plug 4

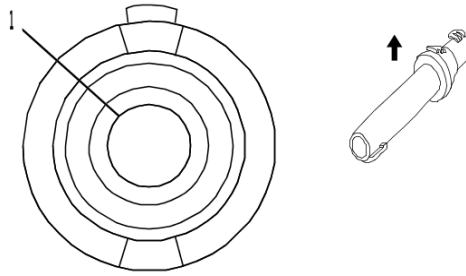

2231591

### Connector Part Information

Harness Type: Diesel Glow Plug Wiring Harness  
 OEM Connector: 55571433  
 Service Connector: Service by Harness - See Part Catalog  
 Description: 1-Way F 4.0 Series( BK)

### Terminal Part Information

Terminal Type ID	Terminated Lead	Diagnostic Test Probe	Terminal Removal Tool
I	Not required	J-35616-37 (L-BU)	No Tool Required

### E12D Glow Plug 4

Pin	Size	Color	Circuit	Function	Terminal Type ID	Option
1	2.5	GY / YE	1584	Glow Plug 4 Control	I	—

E12E Glow Plug 5

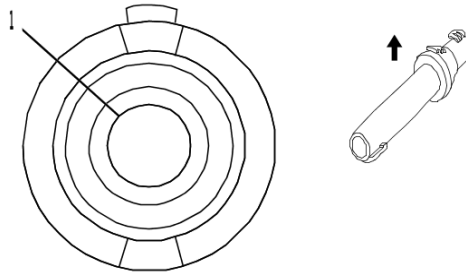

2231591

**Connector Part Information**

Harness Type: Diesel Glow Plug Wiring Harness  
 OEM Connector: 55571433  
 Service Connector: Service by Harness - See Part Catalog  
 Description: 1-Way F 4.0 Series( BK)

**Terminal Part Information**

Terminal Type ID	Terminated Lead	Diagnostic Test Probe	Terminal Removal Tool
I	Not required	J-35616-37 (L-BU)	No Tool Required

**E12E Glow Plug 5**

Pin	Size	Color	Circuit	Function	Terminal Type ID	Option
1	2.5	GY / WH	1585	Glow Plug 5 Control	I	—



## E12F Glow Plug 6

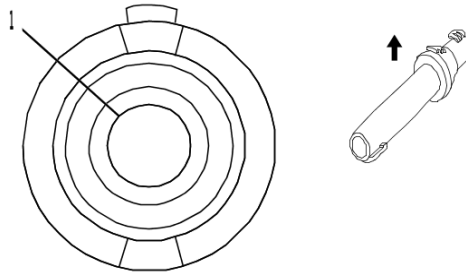

2231591

### Connector Part Information

Harness Type: Diesel Glow Plug Wiring Harness  
 OEM Connector: 55571433  
 Service Connector: Service by Harness - See Part Catalog  
 Description: 1-Way F 4.0 Series( BK)

### Terminal Part Information

Terminal Type ID	Terminated Lead	Diagnostic Test Probe	Terminal Removal Tool
I	Not required	J-35616-37 (L-BU)	No Tool Required

### E12F Glow Plug 6

Pin	Size	Color	Circuit	Function	Terminal Type ID	Option
1	2.5	GY	1586	Glow Plug 6 Control	I	—

E13LA Front Headlamp - Left

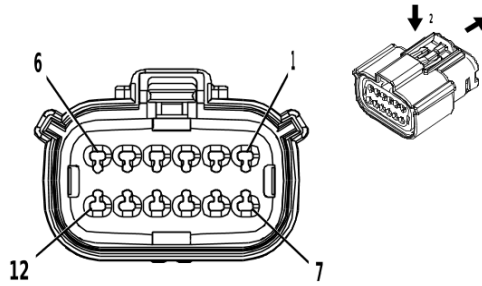

2871860

**Connector Part Information**

Harness Type: Body Wiring Harness  
 OEM Connector: 33472-1266  
 Service Connector: 19352907  
 Description: 12-Way F 1.5 MX Series, Sealed( BK)

**Terminal Part Information**

Terminal Type ID	Terminated Lead	Diagnostic Test Probe	Terminal Removal Tool
I	19368973	J-35616-2A (GY)	J-38125-217

**E13LA Front Headlamp - Left**

Pin	Size	Color	Circuit	Function	Terminal Type ID	Option
1	1	BK	150	Ground	I	—
2	1.5	RD / WH	640	Battery Positive Voltage	I	—
3	0.75	YE	712	Left Headlamp Low Beam Control	I	—
4	0.75	WH	711	Left Headlamp High Beam Control	I	—
5	0.35	GY / BU	7538	Left Front DRL Control	I	—
6	0.5	WH / YE	1254	Left Front Park Lamp Control	I	—
7	0.5	BU / WH	1314	Left Front Turn Signal Lamp Control	I	—
8	0.35	VT / BK	6568	Front Turn Signal Lamp Feedback Signal	I	—
9	0.5	YE / GN	2024	Animation Lighting Control	I	—
10	0.5	GN / VT	1315	Right Front Turn Signal Lamp Control	I	—
11 - 12	—	—	—	Not Occupied	—	—

### E13RA Front Headlamp - Right

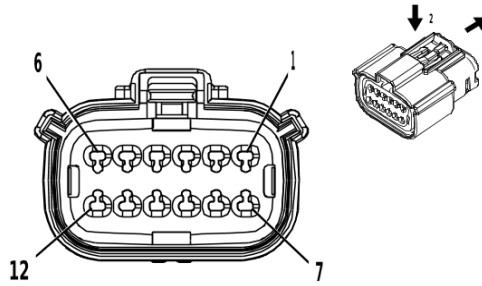

2871860

#### Connector Part Information

Harness Type: Body Wiring Harness  
 OEM Connector: 33472-1266  
 Service Connector: 19352907  
 Description: 12-Way F 1.5 MX Series, Sealed( BK)

#### Terminal Part Information

Terminal Type ID	Terminated Lead	Diagnostic Test Probe	Terminal Removal Tool
I	19368973	J-35616-2A (GY)	J-38125-217

### E13RA Front Headlamp - Right

Pin	Size	Color	Circuit	Function	Terminal Type ID	Option
1	0.75	BK	650	Ground	I	( GF2/ GF5/ GPZ)
	1	BK	650	Ground	I	( - GF2- GF5- GPZ)
2	1.5	RD / YE	740	Battery Positive Voltage	I	—
3	1	YE	312	Right Headlamp Low Beam Control	I	—
4	0.75	WH	311	Right Headlamp High Beam Control	I	—
5	0.35	BU / BN	7539	Right Front DRL Control	I	—
6	0.5	BU / GN	1253	Right Front Park Lamp Control	I	—
7	0.5	GN / VT	1315	Right Front Turn Signal Lamp Control	I	—
8	0.35	WH / YE	7545	Right Front Turn Signal Lamp Feedback Signal	I	—
9	0.5	YE / GN	2024	Animation Lighting Control	I	—
10	0.5	BU / WH	1314	Left Front Turn Signal Lamp Control	I	—
11 - 12	—	—	—	Not Occupied	—	—

**E14A Front Seat Back Heater - Driver**

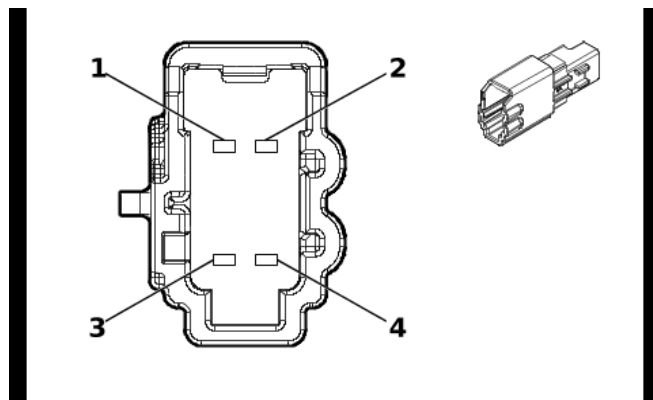

5423974

**Connector Part Information**

Harness Type: Front Seat Wiring Harness - Driver  
 OEM Connector: 6098-9049  
 Service Connector: Service by Harness - See Part Catalog  
 Description: 4-Way M 1.2 MCON Series( GY)

**Terminal Part Information**

Terminal Type ID	Terminated Lead	Diagnostic Test Probe	Terminal Removal Tool
I	Not required	J-35616-13 (BU)	No Tool Required
II	Not required	J-35616-17 (L-GN)	No Tool Required

**E14A Front Seat Back Heater - Driver**

Pin	Size	Color	Circuit	Function	Terminal Type ID	Option
1	0.75	BN	2432	Driver Seat Back Heating Element Control	I	—
2	0.5	BU	2425	Driver Seat Back Heating Temperature Sensor Signal	II	—
3	0.5	BK / YE	2080	Driver Heated Seat Thermistor Low Reference	II	—
4	0.75	BN / BK	2078	Driver Seat Heating Element Low Reference	I	—

## E14B Front Seat Cushion Heater - Driver

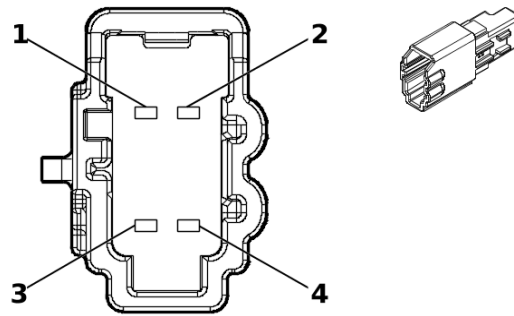

5360963

### Connector Part Information

Harness Type: Front Seat Wiring Harness - Driver  
 OEM Connector: 6098-9046  
 Service Connector: Service by Harness - See Part Catalog  
 Description: 4-Way M 1.2 MCON Series( BK)

### Terminal Part Information

Terminal Type ID	Terminated Lead	Diagnostic Test Probe	Terminal Removal Tool
I	Not required	J-35616-13 (BU)	No Tool Required
II	Not required	J-35616-17 (L-GN)	No Tool Required

### E14B Front Seat Cushion Heater - Driver

Pin	Size	Color	Circuit	Function	Terminal Type ID	Option
1	0.75	BN / VT	2077	Driver Seat Heating Element Control	I	—
2	0.5	YE / GY	2079	Driver Seat Heating Temperature Sensor Signal	II	—
3	0.5	BK / YE	2080	Driver Heated Seat Thermistor Low Reference	II	—
4	0.75	BN / BK	2078	Driver Seat Heating Element Low Reference	I	—

**E14C Front Seat Back Heater - Passenger (KA1)**

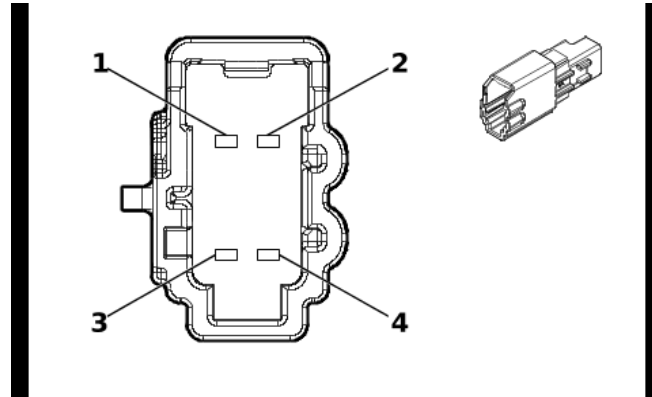

5423974

**Connector Part Information**

Harness Type: Front Seat Wiring Harness - Passenger  
 OEM Connector: 6098-9049  
 Service Connector: Service by Harness - See Part Catalog  
 Description: 4-Way M 1.2 MCON Series( GY)

**Terminal Part Information**

Terminal Type ID	Terminated Lead	Diagnostic Test Probe	Terminal Removal Tool
I	Not required	J-35616-13 (BU)	No Tool Required
II	Not required	J-35616-17 (L-GN)	No Tool Required

**E14C Front Seat Back Heater - Passenger (KA1)**

Pin	Size	Color	Circuit	Function	Terminal Type ID	Option
1	0.75	WH / BN	2481	Passenger Seat Back Heating Element Control	I	—
2	0.5	WH / BU	2436	Passenger Seat Back Heating Temperature Sensor Signal	II	—
3	0.5	BK / GN	2482	Passenger Heated Back Thermistor Low Reference	II	—
4	0.75	GY / BK	2480	Passenger Seat Heating Element Low Reference	I	—

**E14D Front Seat Cushion Heater - Passenger (KA1)**

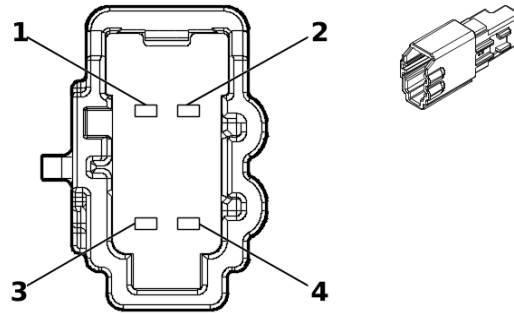

5360963

**Connector Part Information**

Harness Type: Front Seat Wiring Harness - Passenger  
 OEM Connector: 6098-9046  
 Service Connector: Service by Harness - See Part Catalog  
 Description: 4-Way M 1.2 MCON Series( BK)

**Terminal Part Information**

Terminal Type ID	Terminated Lead	Diagnostic Test Probe	Terminal Removal Tool
I	Not required	J-35616-13 (BU)	No Tool Required
II	Not required	J-35616-17 (L-GN)	No Tool Required

**E14D Front Seat Cushion Heater - Passenger (KA1)**

Pin	Size	Color	Circuit	Function	Terminal Type ID	Option
1	0.75	BN / BU	2479	Passenger Seat Heating Element Control	I	—
2	0.5	WH / GY	2434	Passenger Seat Heating Temperature Sensor Signal	II	—
3	0.5	BK / GY	2435	Passenger Heated Seat Thermistor Low Reference	II	—
4	0.75	GY / BK	2480	Passenger Seat Heating Element Low Reference	I	—

**E14F Rear Seat Cushion Heater - Left Rear (KA6)**

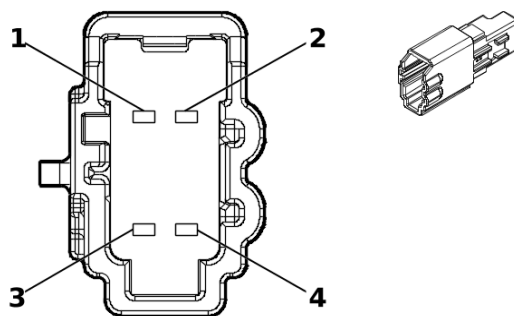

5360963

**Connector Part Information**

Harness Type: Rear Seat Heater Control Wiring Harness  
 OEM Connector: 6098-9046  
 Service Connector: Service by Harness - See Part Catalog  
 Description: 4-Way M 1.2 MCON Series( BK)

**Terminal Part Information**

Terminal Type ID	Terminated Lead	Diagnostic Test Probe	Terminal Removal Tool
I	Not required	J-35616-13 (BU)	No Tool Required

**E14F Rear Seat Cushion Heater - Left Rear (KA6)**

Pin	Size	Color	Circuit	Function	Terminal Type ID	Option
1	0.75	GY	2294	Left Rear Seat Cushion Heating Element Control	I	—
2	0.75	WH / BU	7047	Left Rear Seat Cushion Temperature Sensor Signal	I	—
3	0.75	BU / WH	7048	Left Rear Cushion Thermistor Feedback Signal	I	—
4	0.75	BN / BK	2295	Left Rear Seat Cushion Heating Element Low Reference	I	—



**E14H Rear Seat Cushion Heater - Right Rear (KA6)**

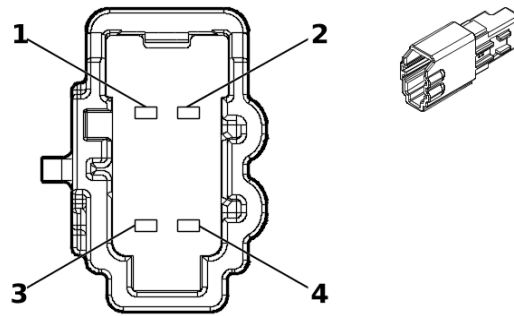

5360963

**Connector Part Information**

Harness Type: Rear Seat Heater Control Wiring Harness  
 OEM Connector: 6098-9046  
 Service Connector: Service by Harness - See Part Catalog  
 Description: 4-Way M 1.2 MCON Series( BK)

**Terminal Part Information**

Terminal Type ID	Terminated Lead	Diagnostic Test Probe	Terminal Removal Tool
I	Not required	J-35616-13 (BU)	No Tool Required

**E14H Rear Seat Cushion Heater - Right Rear (KA6)**

Pin	Size	Color	Circuit	Function	Terminal Type ID	Option
1	0.75	GN / BN	2296	Right Rear Seat Cushion Heating Element Control	I	—
2	0.75	YE / WH	7053	Right Rear Seat Cushion Temperature Sensor Signal	I	—
3	0.75	WH / BK	7054	Right Rear Cushion Thermistor Feedback Signal	I	—
4	0.75	GN / BK	2297	Right Rear Seat Cushion Heating Element Low Reference	I	—

**E18 Rear Window Defogger Grid X1**

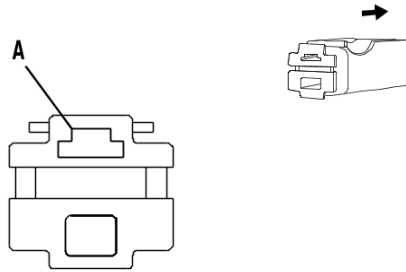

4248834

**Connector Part Information**

Harness Type: Body Wiring Harness  
 OEM Connector: 7123-5014-30  
 Service Connector: 19367647  
 Description: 1-Way F 250 Series( BK)

**Terminal Part Information**

Terminal Type ID	Terminated Lead	Diagnostic Test Probe	Terminal Removal Tool
I	Not required	J-35616-42 (RD)	No Tool Required

**E18 Rear Window Defogger Grid X1**

Pin	Size	Color	Circuit	Function	Terminal Type ID	Option
A	2.5	BN / VT	293	Rear Defogger Grid Control	I	—

## E18 Rear Window Defogger Grid X2

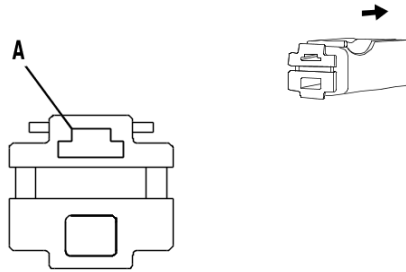

4248834

### Connector Part Information

Harness Type: Body Wiring Harness  
 OEM Connector: 7123-5014-30  
 Service Connector: 19367647  
 Description: 1-Way F 250 Series( BK)

### Terminal Part Information

Terminal Type ID	Terminated Lead	Diagnostic Test Probe	Terminal Removal Tool
I	Not required	J-35616-42 (RD)	No Tool Required

### E18 Rear Window Defogger Grid X2

Pin	Size	Color	Circuit	Function	Terminal Type ID	Option
A	2.5	BK	1450	Ground	I	—

**E28 Front Floor Console Compartment Lamp**

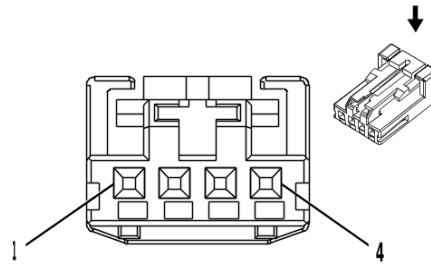

2717162

**Connector Part Information**

Harness Type: Front Floor Console Wiring Harness  
 OEM Connector: 1-936119-1  
 Service Connector: Service by Harness - See Part Catalog  
 Description: 4-Way F 0.64 Micro-Quadlock Series( BK)

**Terminal Part Information**

Terminal Type ID	Terminated Lead	Diagnostic Test Probe	Terminal Removal Tool
I	Not required	J-35616-64B (L-BU)	No Tool Required

**E28 Front Floor Console Compartment Lamp**

Pin	Size	Color	Circuit	Function	Terminal Type ID	Option
1	0.35	BK	1451	Signal Ground	I	—
2	—	—	—	Not Occupied	—	—
3	0.5	GN / VT	4786	Dome/Reading Lamp Enable Signal	I	—
4	—	—	—	Not Occupied	—	—

**E29LF Front Fog Lamp - Left (T3U - VHU)**

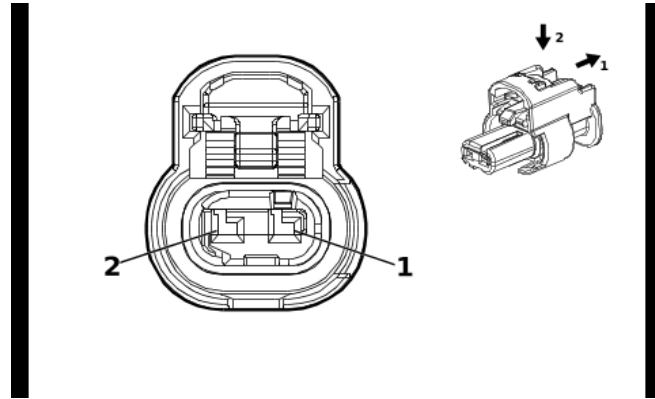

4649903

**Connector Part Information**

Harness Type: Front Object Alarm Sensor Wiring Harness  
 OEM Connector: 1-2296694-1  
 Service Connector: Service by Harness - See Part Catalog  
 Description: 2-Way F 1.2 MCON Series, Sealed( BK)

**Terminal Part Information**

Terminal Type ID	Terminated Lead	Diagnostic Test Probe	Terminal Removal Tool
I	Not required	J-35616-12 (BU)	No Tool Required

**E29LF Front Fog Lamp - Left (T3U - VHU)**

Pin	Size	Color	Circuit	Function	Terminal Type ID	Option
1	0.5	BK	650	Ground	I	—
2	0.5	BN / GY	5061	Left Front Fog Lamp Control	I	—

**E29LF Front Fog Lamp - Left (T3U & VHU)**

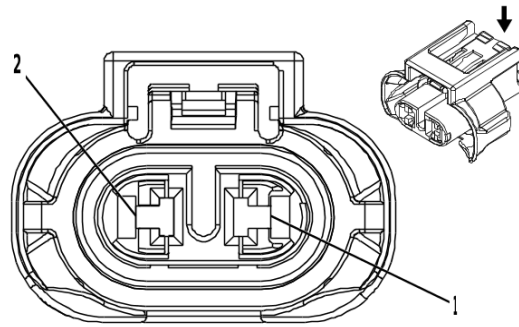

3404058

**Connector Part Information**

Harness Type: Front Object Alarm Sensor Wiring Harness  
 OEM Connector: 13930730  
 Service Connector: Service by Harness - See Part Catalog  
 Description: 2-Way F 2.8 APEX Series, Sealed( BK)

**Terminal Part Information**

Terminal Type ID	Terminated Lead	Diagnostic Test Probe	Terminal Removal Tool
I	Not required	J-35616-4A (PU)	No Tool Required

**E29LF Front Fog Lamp - Left (T3U & VHU)**

Pin	Size	Color	Circuit	Function	Terminal Type ID	Option
1	0.5	BN / GY	5061	Left Front Fog Lamp Control	I	—
2	0.5	BK	650	Ground	I	—

**E29RF Front Fog Lamp - Right (T3U - VHU)**

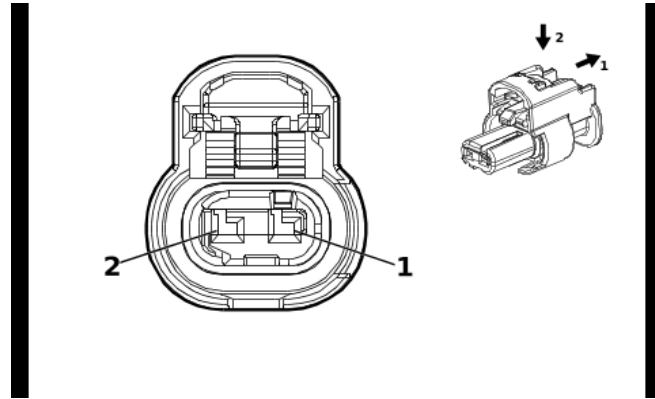

4649903

**Connector Part Information**

Harness Type: Front Object Alarm Sensor Wiring Harness  
 OEM Connector: 1-2296694-1  
 Service Connector: Service by Harness - See Part Catalog  
 Description: 2-Way F 1.2 MCON Series, Sealed( BK)

**Terminal Part Information**

Terminal Type ID	Terminated Lead	Diagnostic Test Probe	Terminal Removal Tool
I	Not required	J-35616-12 (BU)	No Tool Required

**E29RF Front Fog Lamp - Right (T3U - VHU)**

Pin	Size	Color	Circuit	Function	Terminal Type ID	Option
1	0.5	BK	650	Ground	I	—
2	0.5	BN / GN	5062	Right Front Fog Lamp Control	I	—

**E29RF Front Fog Lamp - Right (T3U & VHU)**

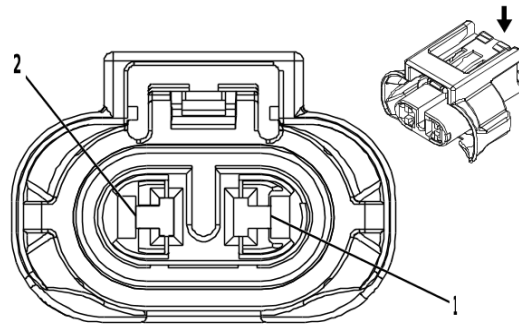

3404058

**Connector Part Information**

Harness Type: Front Object Alarm Sensor Wiring Harness  
 OEM Connector: 13930730  
 Service Connector: Service by Harness - See Part Catalog  
 Description: 2-Way F 2.8 APEX Series, Sealed( BK)

**Terminal Part Information**

Terminal Type ID	Terminated Lead	Diagnostic Test Probe	Terminal Removal Tool
I	Not required	J-35616-4A (PU)	No Tool Required

**E29RF Front Fog Lamp - Right (T3U & VHU)**

Pin	Size	Color	Circuit	Function	Terminal Type ID	Option
1	0.5	BN / GN	5062	Right Front Fog Lamp Control	I	—
2	0.5	BK	650	Ground	I	—



**E31L Sunshade Mirror Lamp - Left**

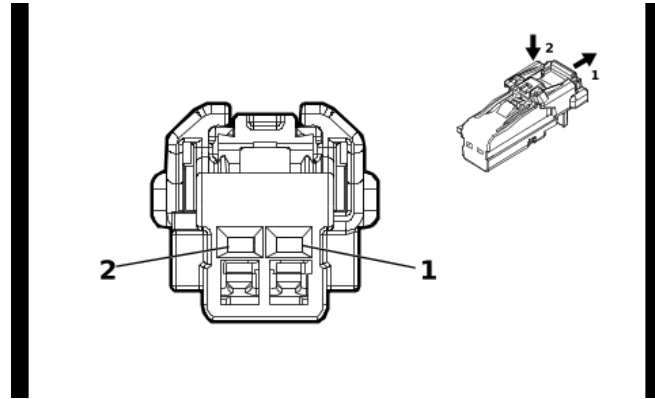

5377746

**Connector Part Information**

Harness Type: Dome Lamp Wiring Harness  
 OEM Connector: 35327306  
 Service Connector: Service by Harness - See Part Catalog  
 Description: 2-Way F 1.2 MCON Series( BN)

**Terminal Part Information**

Terminal Type ID	Terminated Lead	Diagnostic Test Probe	Terminal Removal Tool
I	Not required	No Tool Required	No Tool Required

**E31L Sunshade Mirror Lamp - Left**

Pin	Size	Color	Circuit	Function	Terminal Type ID	Option
1	—	BU / GN	4785	Interior Lamp Overhead Enable Signal	I	—
2	—	BK	1050	Ground	I	—

**E31R Sunshade Mirror Lamp - Right**

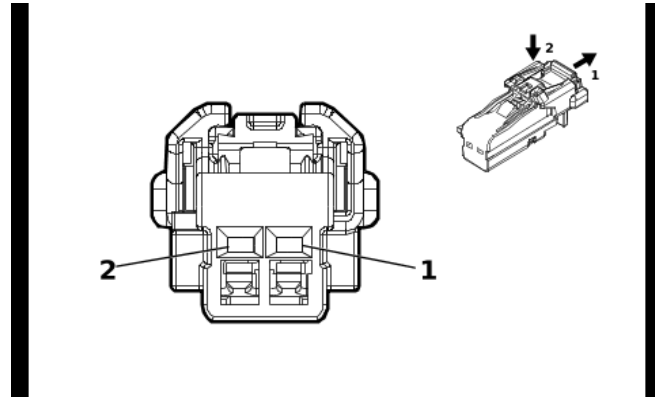

5377746

**Connector Part Information**

Harness Type: Dome Lamp Wiring Harness  
 OEM Connector: 35327306  
 Service Connector: Service by Harness - See Part Catalog  
 Description: 2-Way F 1.2 MCON Series( BN)

**Terminal Part Information**

Terminal Type ID	Terminated Lead	Diagnostic Test Probe	Terminal Removal Tool
I	Not required	No Tool Required	No Tool Required

**E31R Sunshade Mirror Lamp - Right**

Pin	Size	Color	Circuit	Function	Terminal Type ID	Option
1	—	GY / WH	2369	Interior Lamp Overhead 2 Enable Signal	I	—
2	—	BK	1050	Ground	I	—

**E33L Cargo Lamp - Left (UF2)**

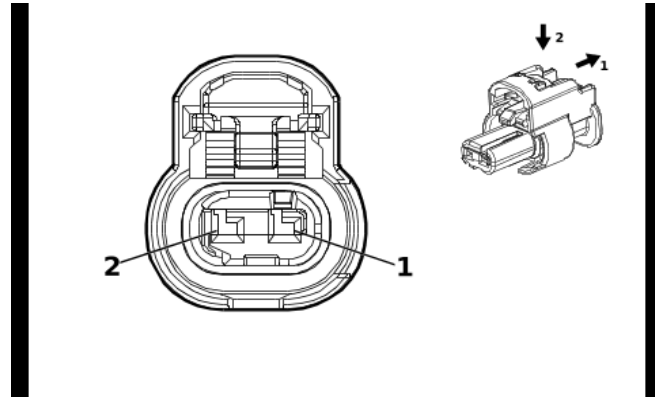

4649903

**Connector Part Information**

Harness Type: Tail Lamp Wiring Harness - Left  
 OEM Connector: 13512365  
 Service Connector: Service by Harness - See Part Catalog  
 Description: 2-Way F 1.2 MCON Series, Sealed( BK)

**Terminal Part Information**

Terminal Type ID	Terminated Lead	Diagnostic Test Probe	Terminal Removal Tool
I	Not required	J-35616-12 (BU)	No Tool Required

**E33L Cargo Lamp - Left (UF2)**

Pin	Size	Color	Circuit	Function	Terminal Type ID	Option
1	0.75	BU	7762	Cargo Lamp Control	I	—
2	0.75	BK	1951	Signal Ground	I	—

**E33LB Cargo Box Lamp Bulb - Left - Regular Cab**

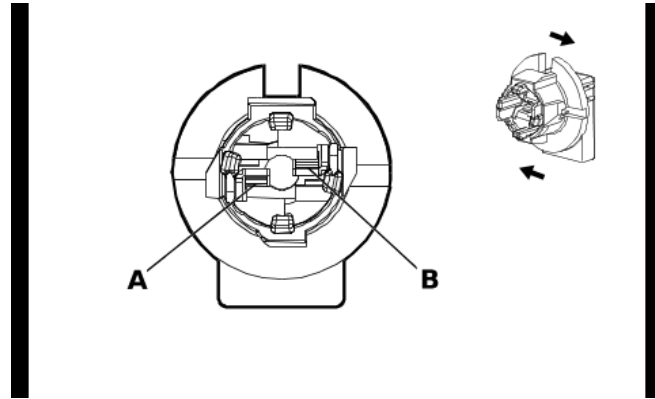

5913172

**Connector Part Information**

Harness Type: High Mount Stop Lamp Wiring Harness  
 OEM Connector: ZCF-02075-01  
 Service Connector: Service by Harness - See Part Catalog  
 Description: 2-Way F Socket( GY)

**Terminal Part Information**

Terminal Type ID	Terminated Lead	Diagnostic Test Probe	Terminal Removal Tool
I	Not required	Not Available	No Tool Required

**E33LB Cargo Box Lamp Bulb - Left - Regular Cab**

Pin	Size	Color	Circuit	Function	Terminal Type ID	Option
A	0.75	BN	1430	Exterior Courtesy Lamp Control	I	—
B	0.75	BK	1050	Ground	I	—

**E33R Cargo Lamp - Right (UF2)**

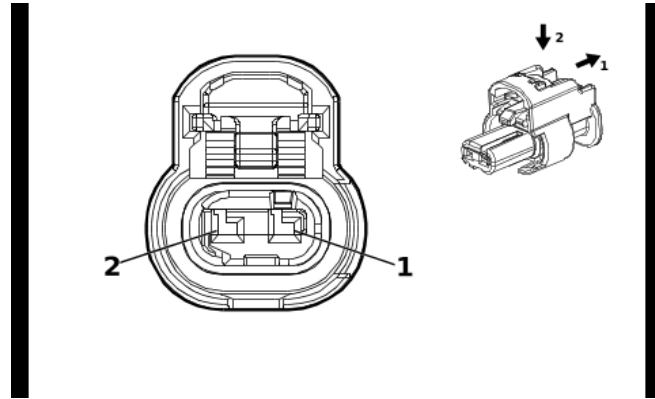

4649903

**Connector Part Information**

Harness Type: Tail Lamp Wiring Harness - Right  
 OEM Connector: 13512365  
 Service Connector: Service by Harness - See Part Catalog  
 Description: 2-Way F 1.2 MCON Series, Sealed( BK)

**Terminal Part Information**

Terminal Type ID	Terminated Lead	Diagnostic Test Probe	Terminal Removal Tool
I	Not required	J-35616-12 (BU)	No Tool Required

**E33R Cargo Lamp - Right (UF2)**

Pin	Size	Color	Circuit	Function	Terminal Type ID	Option
1	0.75	BU	7762	Cargo Lamp Control	I	—
2	0.75	BK	1850	Ground	I	—

**E33RB Cargo Box Lamp Bulb - Right - Regular Cab**

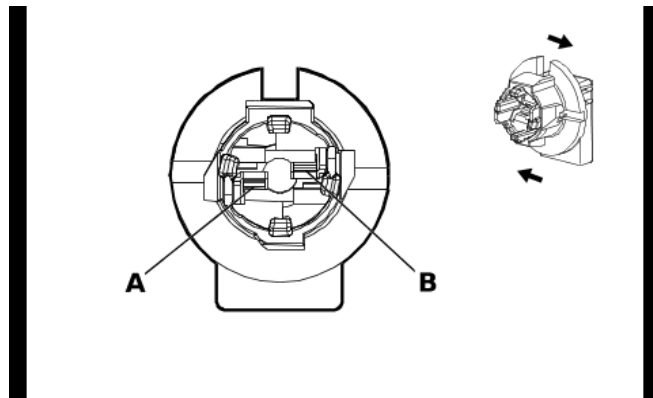

5913172

**Connector Part Information**

Harness Type: High Mount Stop Lamp Wiring Harness  
 OEM Connector: ZCF-02075-01  
 Service Connector: Service by Harness - See Part Catalog  
 Description: 2-Way F Socket( GY)

**Terminal Part Information**

Terminal Type ID	Terminated Lead	Diagnostic Test Probe	Terminal Removal Tool
I	Not required	Not Available	No Tool Required

**E33RB Cargo Box Lamp Bulb - Right - Regular Cab**

Pin	Size	Color	Circuit	Function	Terminal Type ID	Option
A	0.75	BK	1050	Ground	I	—
	0.75	BK	1050	Ground		—
B	0.75	BN	1430	Exterior Courtesy Lamp Control	I	—
	0.75	BN	1430	Exterior Courtesy Lamp Control		—

**E33TH Rear Closure Auxiliary Signal Lamp (QT5 / QT6)**

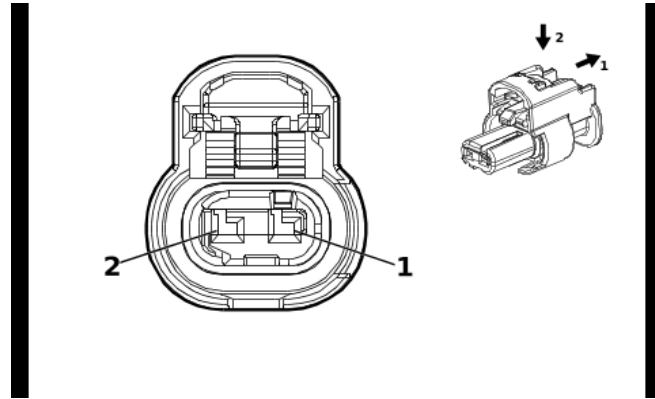

4649903

**Connector Part Information**

Harness Type: Endgate Wiring Harness  
 OEM Connector: 1-2296694-1  
 Service Connector: Service by Harness - See Part Catalog  
 Description: 2-Way F 1.2 MCON Series, Sealed( BK)

**Terminal Part Information**

Terminal Type ID	Terminated Lead	Diagnostic Test Probe	Terminal Removal Tool
I	Not required	J-35616-12 (BU)	No Tool Required

**E33TH Rear Closure Auxiliary Signal Lamp (QT5 / QT6)**

Pin	Size	Color	Circuit	Function	Terminal Type ID	Option
1	0.5	WH / VT	1430	Exterior Courtesy Lamp Control	I	—
2	0.5	BK	1850	Ground	I	—

**E37SMC Rear Seat Position Center Reading and Courtesy Lamp**

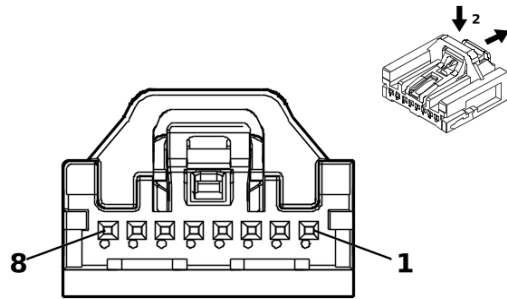

5200269

**Connector Part Information**

Harness Type: Dome Lamp Wiring Harness  
 OEM Connector: 35068228  
 Service Connector: 84769201  
 Description: 8-Way F Mini 50 Series( BK)

**Terminal Part Information**

Terminal Type ID	Terminated Lead	Diagnostic Test Probe	Terminal Removal Tool
I	Not required	EL-35616-58 (BK)	No Tool Required

**E37SMC Rear Seat Position Center Reading and Courtesy Lamp**

Pin	Size	Color	Circuit	Function	Terminal Type ID	Option
1	0.35	GN / YE	2903	Row 2 Dome Reading Lamp Interior Lamp Control	I	—
2	0.35	BN / BU	2905	Row 2 Dome Reading Lamp 2 Interior Lamp Control	I	—
3	0.35	BK	1050	Ground	I	—
4	0.35	WH / BN	2904	Row 2 Dome Reading Lamp Switch Signal	I	—
5	0.35	VT / GY	2906	Row 2 Dome Reading Lamp 2 Switch Signal	I	—
6 - 8	—	—	—	Not Occupied	—	—



**E40 Air Heater X1 (C32)**

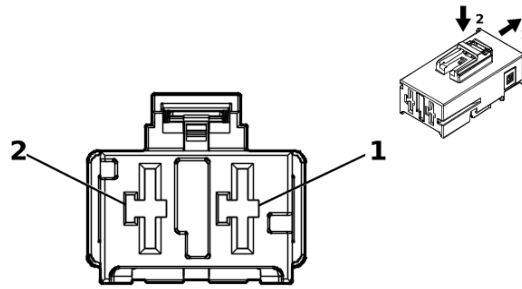

5187955

**Connector Part Information**

Harness Type: Auxiliary Heater Wiring Harness  
 OEM Connector: 13525311  
 Service Connector: Service by Harness - See Part Catalog  
 Description: 2-Way F 9.5 MCON-LL Series( BK)

**Terminal Part Information**

Terminal Type ID	Terminated Lead	Diagnostic Test Probe	Terminal Removal Tool
I	Not required	J-35616-22 (RD)	No Tool Required

**E40 Air Heater X1 (C32)**

Pin	Size	Color	Circuit	Function	Terminal Type ID	Option
1	—	—	—	Not Occupied	—	—
2	10	RD / GY	642	Battery Positive Voltage	I	—

E40 Air Heater X2 (C32)

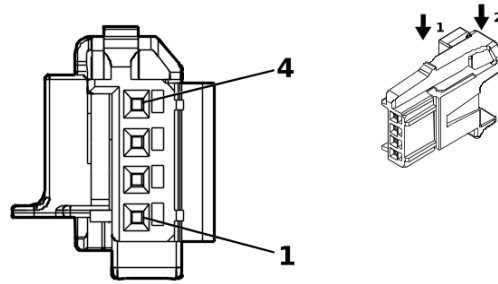

5191926

**Connector Part Information**

Harness Type: Heater Wiring Harness  
 OEM Connector: 2294399-1  
 Service Connector: Service by Harness - See Part Catalog  
 Description: 4-Way F 0.64 Micro-Quadlock Series( BK)

**Terminal Part Information**

Terminal Type ID	Terminated Lead	Diagnostic Test Probe	Terminal Removal Tool
I	Not required	J-35616-64B (L-BU)	No Tool Required

**E40 Air Heater X2 (C32)**

Pin	Size	Color	Circuit	Function	Terminal Type ID	Option
1	—	—	—	Not Occupied	—	—
2	0.35	BN / VT	339	Run/Crank Ignition 1 Voltage	I	—
3	0.35	BU	2852	Body Control Module LIN Bus 6	I	—
4	0.35	BK	1050	Ground	I	—

## E40 Air Heater X3 (C32)

—

### Connector Part Information

Harness Type: Auxiliary Heater Wiring Harness  
 OEM Connector: 20000001  
 Service Connector: Service by Harness - See Part Catalog  
 Description: 1-Way

### Terminal Part Information

Terminal Type ID	Terminated Lead	Diagnostic Test Probe	Terminal Removal Tool
I	Not required	No Tool Required	No Tool Required

### E40 Air Heater X3 (C32)

Pin	Size	Color	Circuit	Function	Terminal Type ID	Option
1	10	BK	750	Ground	I	—

**E42L Rear Body Structure Stop Lamp - Left (GF4 / GF9 / GFC / GFD / GRZ)**

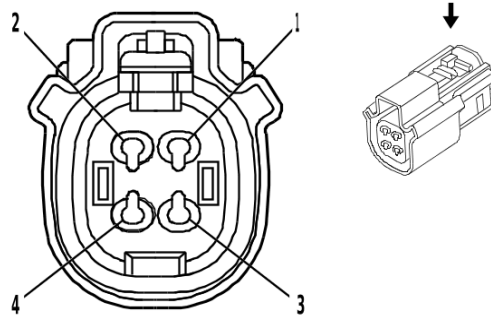

1960031

**Connector Part Information**

Harness Type: Tail Lamp Wiring Harness - Left  
 OEM Connector: 33472-4006  
 Service Connector: Service by Harness - See Part Catalog  
 Description: 4-Way F 1.5 MX Series, Sealed( BK)

**Terminal Part Information**

Terminal Type ID	Terminated Lead	Diagnostic Test Probe	Terminal Removal Tool
I	Not required	J-35616-2A (GY)	No Tool Required

**E42L Rear Body Structure Stop Lamp - Left (GF4 / GF9 / GFC / GFD / GRZ)**

Pin	Size	Color	Circuit	Function	Terminal Type ID	Option
1	0.75	BN	6993	Left Rear Park Lamp Control	I	—
2	0.75	RD	6567	Rear Turn Signal Lamp Feedback Signal	I	—
3	0.75	GN / GN	1334	Left Rear Turn Signal Lamp Control 2	I	—
4	0.75	BK	1951	Signal Ground	I	—

**E42L Rear Body Structure Stop Lamp - Left - Regular Cab**

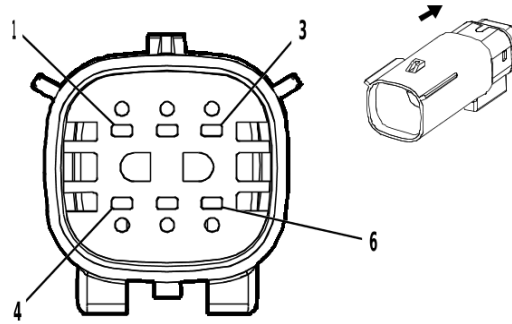

1986159

**Connector Part Information**

Harness Type: Chassis Wiring Harness  
 OEM Connector: 33482-3601  
 Service Connector: 19367742  
 Description: 6-Way M 1.5 MX Series, Sealed( BK)

**Terminal Part Information**

Terminal Type ID	Terminated Lead	Diagnostic Test Probe	Terminal Removal Tool
I	Not required	J-35616-3 (GY)	No Tool Required

**E42L Rear Body Structure Stop Lamp - Left - Regular Cab**

Pin	Size	Color	Circuit	Function	Terminal Type ID	Option
1	0.75	BN / BU	6993	Left Rear Park Lamp Control	I	—
2	0.75	WH / VT	6567	Rear Turn Signal Lamp Feedback Signal	I	—
3	0.5	GY / BU	7762	Cargo Lamp Control	I	—
4	0.5	GN / WH	24	Backup Lamp Control	I	—
5	0.75	BU / WH	1334	Left Rear Turn Signal Lamp Control 2	I	—
6	0.75	BK	1951	Signal Ground	I	—

**E42R Rear Body Structure Stop Lamp - Right (GF4 / GF9 / GFC / GFD / GRZ)**

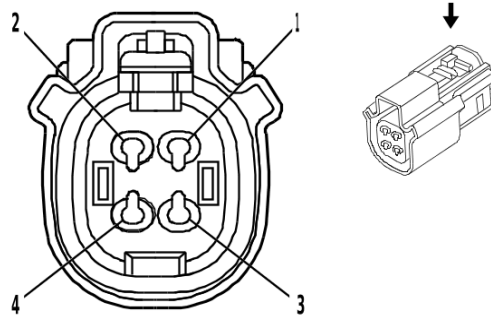

1960031

**Connector Part Information**

Harness Type: Tail Lamp Wiring Harness - Right  
 OEM Connector: 33472-4006  
 Service Connector: Service by Harness - See Part Catalog  
 Description: 4-Way F 1.5 MX Series, Sealed( BK)

**Terminal Part Information**

Terminal Type ID	Terminated Lead	Diagnostic Test Probe	Terminal Removal Tool
I	Not required	J-35616-2A (GY)	No Tool Required

**E42R Rear Body Structure Stop Lamp - Right (GF4 / GF9 / GFC / GFD / GRZ)**

Pin	Size	Color	Circuit	Function	Terminal Type ID	Option
1	0.75	BN / BN	6995	Right Rear Park Lamp Control	I	—
2	0.75	RD	7544	Right Rear Turn Signal Lamp Feedback Signal	I	—
3	0.75	GN	1335	Right Rear Turn Signal Lamp Control 2	I	—
4	0.75	BK	1850	Ground	I	—

**E52 Reductant Heater 2 - Injector Supply Pipe (LZ0)**

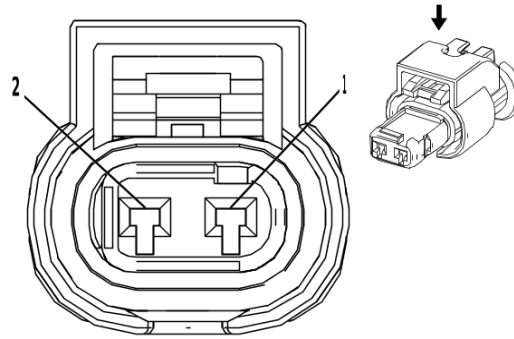

2474752

**Connector Part Information**

Harness Type: Emission Reduction Fluid Tank Reservoir Wire Harness  
 OEM Connector: 13586143  
 Service Connector: Service by Harness - See Part Catalog  
 Description: 2-Way F 1.2 MCON Series, Sealed( BK)

**Terminal Part Information**

Terminal Type ID	Terminated Lead	Diagnostic Test Probe	Terminal Removal Tool
I	Not required	J-35616-16 (L-GN)	No Tool Required

**E52 Reductant Heater 2 - Injector Supply Pipe (LZ0)**

Pin	Size	Color	Circuit	Function	Terminal Type ID	Option
1	1	WH	3199	Diesel Exhaust Fluid Pressure Line Heater Control	I	—
2	1	BN	4319	Diesel Exhaust Fluid Line Heater Low Control	I	—

**E63D Front Side Door Inside Handle Illumination Lamp - Left**

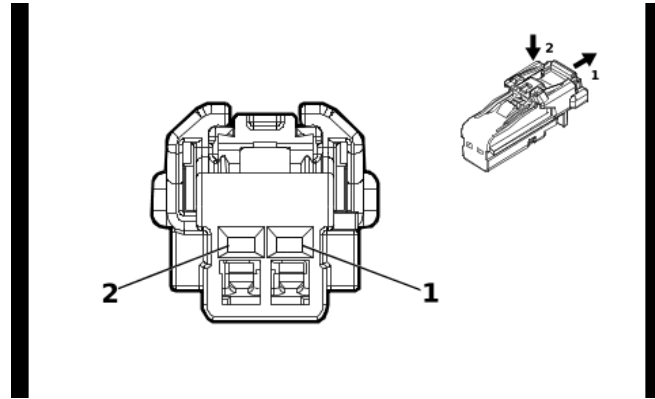

4115691

**Connector Part Information**

Harness Type: Front Side Door Door Lock Door Wiring Harness - Driver  
 OEM Connector: 6098-8988  
 Service Connector: Service by Harness - See Part Catalog  
 Description: 2-Way F 1.2 MCON Series( BK)

**Terminal Part Information**

Terminal Type ID	Terminated Lead	Diagnostic Test Probe	Terminal Removal Tool
I	Not required	J-35616-16 (L-GN)	No Tool Required

**E63D Front Side Door Inside Handle Illumination Lamp - Left**

Pin	Size	Color	Circuit	Function	Terminal Type ID	Option
1	0.5	GY / VT	2767	LED Ambient Lighting Control Left Front Door	I	—
2	0.5	BK	1550	Ground	I	—



**E63P Front Side Door Inside Handle Illumination Lamp - Right**

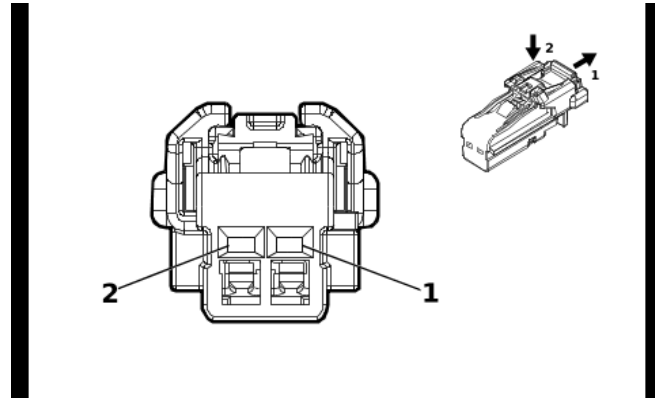

4115691

**Connector Part Information**

Harness Type: Front Side Door Door Lock Door Wiring Harness - Passenger  
 OEM Connector: 6098-8988  
 Service Connector: Service by Harness - See Part Catalog  
 Description: 2-Way F 1.2 MCON Series( BK)

**Terminal Part Information**

Terminal Type ID	Terminated Lead	Diagnostic Test Probe	Terminal Removal Tool
I	Not required	J-35616-16 (L-GN)	No Tool Required

**E63P Front Side Door Inside Handle Illumination Lamp - Right**

Pin	Size	Color	Circuit	Function	Terminal Type ID	Option
1	0.5	WH / BN	2768	LED Ambient Lighting Control Right Front Door	I	—
2	0.5	BK	1350	Ground	I	—

**E135L Front Bumper Fascia Auxiliary Signal Lamp - Left (GRZ)**

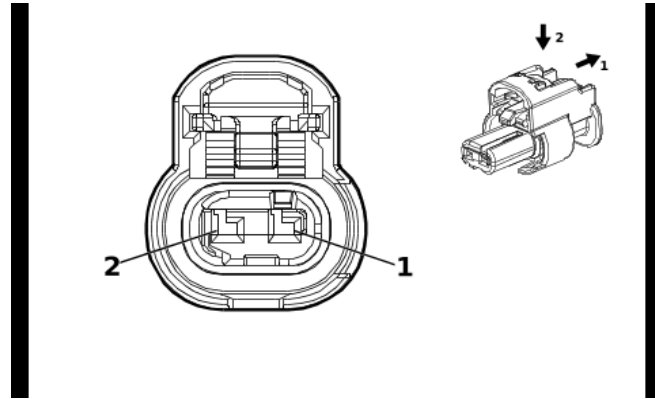

4649903

**Connector Part Information**

Harness Type: Front View Camera Switch Wiring Harness  
 OEM Connector: 1-2296694-1  
 Service Connector: Service by Harness - See Part Catalog  
 Description: 2-Way F 1.2 MCON Series, Sealed( BK)

**Terminal Part Information**

Terminal Type ID	Terminated Lead	Diagnostic Test Probe	Terminal Removal Tool
I	Not required	J-35616-16 (L-GN)	No Tool Required

**E135L Front Bumper Fascia Auxiliary Signal Lamp - Left (GRZ)**

Pin	Size	Color	Circuit	Function	Terminal Type ID	Option
1	1.5	BK	650	Ground	I	—
2	1.5	BN / GN	4246	Identification Lamp Control	I	—

**E135R Front Bumper Fascia Auxiliary Signal Lamp - Right (GRZ)**

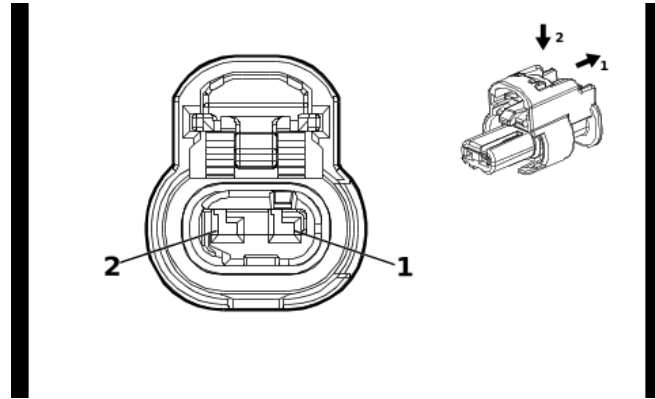

4649903

**Connector Part Information**

Harness Type: Front View Camera Switch Wiring Harness  
 OEM Connector: 1-2296694-1  
 Service Connector: Service by Harness - See Part Catalog  
 Description: 2-Way F 1.2 MCON Series, Sealed( BK)

**Terminal Part Information**

Terminal Type ID	Terminated Lead	Diagnostic Test Probe	Terminal Removal Tool
I	Not required	J-35616-16 (L-GN)	No Tool Required

**E135R Front Bumper Fascia Auxiliary Signal Lamp - Right (GRZ)**

Pin	Size	Color	Circuit	Function	Terminal Type ID	Option
1	1.5	BK	650	Ground	I	—
2	1.5	BN / GN	4246	Identification Lamp Control	I	—

**F101 Instrument Panel Airbag X1**

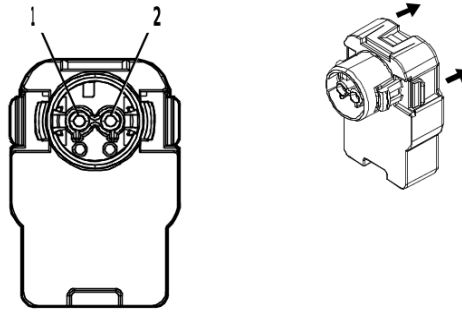

4823732

**Connector Part Information**

Harness Type: Instrument Panel Airbag Wiring Harness  
 OEM Connector: 13530531  
 Service Connector: Service by Harness - See Part Catalog  
 Description: 2-Way

**Terminal Part Information**

Terminal Type ID	Terminated Lead	Diagnostic Test Probe	Terminal Removal Tool
I	Not required	No Tool Required	No Tool Required

**F101 Instrument Panel Airbag X1**

Pin	Size	Color	Circuit	Function	Terminal Type ID	Option
1	0.35	YE / OG	3025	Passenger Instrument Panel Air Bag Stage 1 High Control	I	—
2	0.35	OG / WH	3024	Passenger Instrument Panel Air Bag Stage 1 Low Control	I	—

**F101 Instrument Panel Airbag X2**

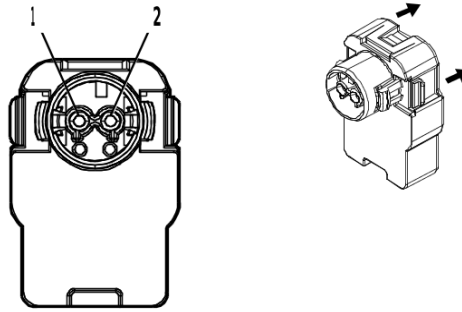

4772246

**Connector Part Information**

Harness Type: Instrument Panel Airbag Wiring Harness  
 OEM Connector: 13530532  
 Service Connector: Service by Harness - See Part Catalog  
 Description: 2-Way

**Terminal Part Information**

Terminal Type ID	Terminated Lead	Diagnostic Test Probe	Terminal Removal Tool
I	Not required	No Tool Required	No Tool Required

**F101 Instrument Panel Airbag X2**

Pin	Size	Color	Circuit	Function	Terminal Type ID	Option
1	0.35	GY / OG	3027	Passenger Instrument Panel Air Bag Stage 2 High Control	I	—
2	0.35	OG / VT	3026	Passenger Instrument Panel Air Bag Stage 2 Low Control	I	—

**F105LF Front Row Roof Rail Airbag - Left**

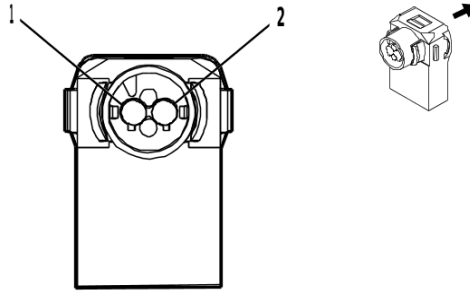

4679778

**Connector Part Information**

Harness Type: Body Wiring Harness  
 OEM Connector: 33345783  
 Service Connector: 85666124  
 Description: 2-Way F ABX-5 Series( GY with YE Cover)

**Terminal Part Information**

Terminal Type ID	Terminated Lead	Diagnostic Test Probe	Terminal Removal Tool
I	Not required	J-35616-10 (GN)	No Tool Required

**F105LF Front Row Roof Rail Airbag - Left**

Pin	Size	Color	Circuit	Function	Terminal Type ID	Option
1	0.5	OG / GN	5019	Left Front Roof Rail Air Bag High Control	I	—
2	0.5	VT / OG	5020	Left Front Roof Rail Air Bag Low Control	I	—

**F105RF Front Row Roof Rail Airbag - Right**

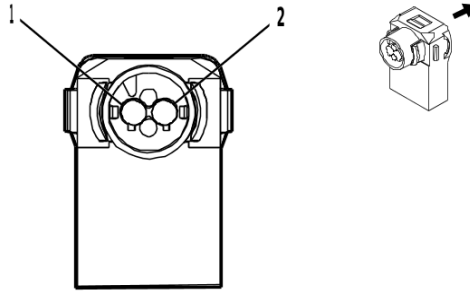

4679778

**Connector Part Information**

Harness Type: Body Wiring Harness  
 OEM Connector: 33345783  
 Service Connector: 85666124  
 Description: 2-Way F ABX-5 Series( GY with YE Cover)

**Terminal Part Information**

Terminal Type ID	Terminated Lead	Diagnostic Test Probe	Terminal Removal Tool
I	Not required	J-35616-10 (GN)	No Tool Required

**F105RF Front Row Roof Rail Airbag - Right**

Pin	Size	Color	Circuit	Function	Terminal Type ID	Option
1	0.5	OG / GY	5021	Right Front Roof Rail Air Bag High Control	I	—
2	0.5	WH / OG	5022	Right Front Roof Rail Air Bag Low Control	I	—

F106D Front Seat Outboard Seat Back Airbag - Driver

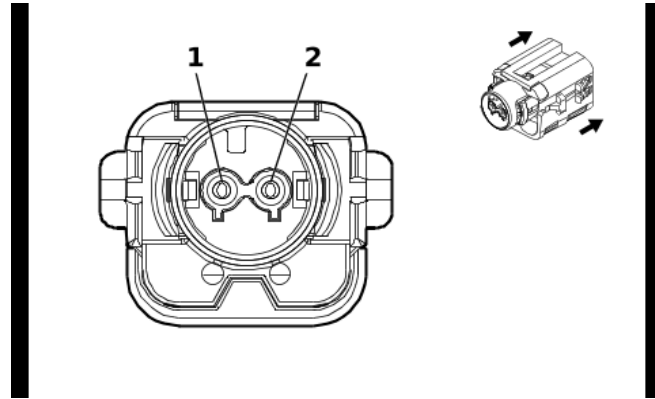

5499727

**Connector Part Information**

Harness Type: Front Seat Wiring Harness - Driver  
 OEM Connector: 13535270  
 Service Connector: Service by Harness - See Part Catalog  
 Description: 2-Way F ABX-5 Series( PK with YE Cover)

**Terminal Part Information**

Terminal Type ID	Terminated Lead	Diagnostic Test Probe	Terminal Removal Tool
I	Not required	J-35616-10 (GN)	No Tool Required

**F106D Front Seat Outboard Seat Back Airbag - Driver**

Pin	Size	Color	Circuit	Function	Terminal Type ID	Option
1	0.5	OG / BU	4962	Driver Seat Back Air Bag High Control	I	—
2	0.5	BK / OG	4963	Driver Seat Back Air Bag Low Control	I	—



**F106P Front Seat Outboard Seat Back Airbag - Passenger**

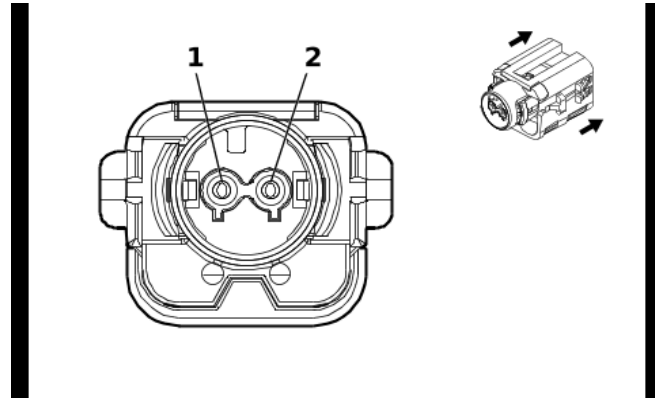

5499727

**Connector Part Information**

Harness Type: Front Seat Wiring Harness - Passenger  
 OEM Connector: 13535270  
 Service Connector: Service by Harness - See Part Catalog  
 Description: 2-Way F ABX-5 Series( PK with YE Cover)

**Terminal Part Information**

Terminal Type ID	Terminated Lead	Diagnostic Test Probe	Terminal Removal Tool
I	Not required	J-35616-10 (GN)	No Tool Required

**F106P Front Seat Outboard Seat Back Airbag - Passenger**

Pin	Size	Color	Circuit	Function	Terminal Type ID	Option
1	0.5	OG / GY	4956	Passenger Seat Back Air Bag High Control	I	—
2	0.5	BU / OG	4957	Passenger Seat Back Air Bag Low Control	I	—

F107 Steering Wheel Airbag X1 (N57 - D07)

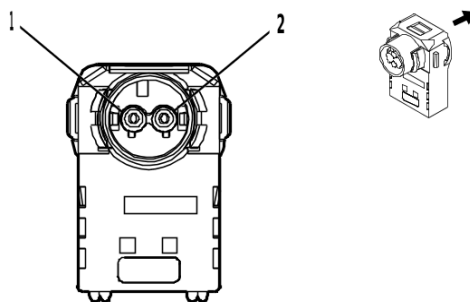

4231869

**Connector Part Information**

Harness Type: Steering Wheel Horn Switch Wiring Harness  
 OEM Connector: 13545486  
 Service Connector: Service by Harness - See Part Catalog  
 Description: 2-Way F ABX-5 Series( PK with YE Cover)

**Terminal Part Information**

Terminal Type ID	Terminated Lead	Diagnostic Test Probe	Terminal Removal Tool
I	Not required	J-35616-10 (GN)	No Tool Required

**F107 Steering Wheel Airbag X1 (N57 - D07)**

Pin	Size	Color	Circuit	Function	Terminal Type ID	Option
1	0.5	YE / OG	3021	Steering Wheel Air Bag Stage 1 High Control	I	—
2	0.5	OG / WH	3020	Steering Wheel Air Bag Stage 1 Low Control	I	—

**F107 Steering Wheel Airbag X1 (NK5 / D07)**

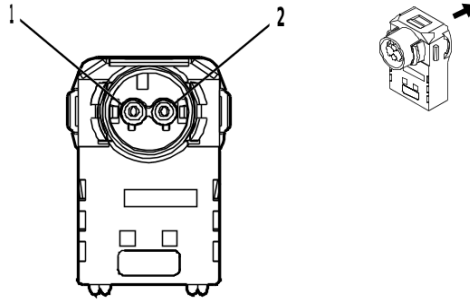

4231869

**Connector Part Information**

Harness Type: Steering Wheel Horn Switch Wiring Harness  
 OEM Connector: 13516028  
 Service Connector: Service by Harness - See Part Catalog  
 Description: 2-Way F ABX-5 Series( PK with YE Cover)

**Terminal Part Information**

Terminal Type ID	Terminated Lead	Diagnostic Test Probe	Terminal Removal Tool
I	Not required	J-35616-10 (GN)	No Tool Required

**F107 Steering Wheel Airbag X1 (NK5 / D07)**

Pin	Size	Color	Circuit	Function	Terminal Type ID	Option
1	0.5	OG / VT	3021	Steering Wheel Air Bag Stage 1 High Control	I	—
2	0.5	BN / OG	3020	Steering Wheel Air Bag Stage 1 Low Control	I	—

**F107 Steering Wheel Airbag X2 (N57 - D07)**

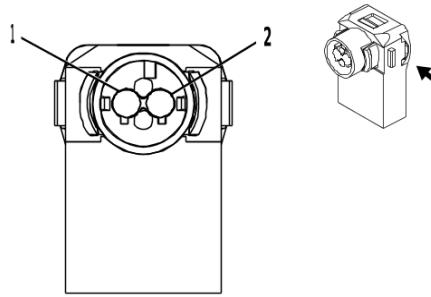

4241364

**Connector Part Information**

Harness Type: Steering Wheel Horn Switch Wiring Harness  
 OEM Connector: 13545487  
 Service Connector: Service by Harness - See Part Catalog  
 Description: 2-Way F ABX-5 Series( PU with YE Cover)

**Terminal Part Information**

Terminal Type ID	Terminated Lead	Diagnostic Test Probe	Terminal Removal Tool
I	Not required	J-35616-10 (GN)	No Tool Required

**F107 Steering Wheel Airbag X2 (N57 - D07)**

Pin	Size	Color	Circuit	Function	Terminal Type ID	Option
1	0.5	GY / OG	3023	Steering Wheel Air Bag Stage 2 High Control	I	—
2	0.5	OG / VT	3022	Steering Wheel Air Bag Stage 2 Low Control	I	—

**F107 Steering Wheel Airbag X2 (NK5 / D07)**

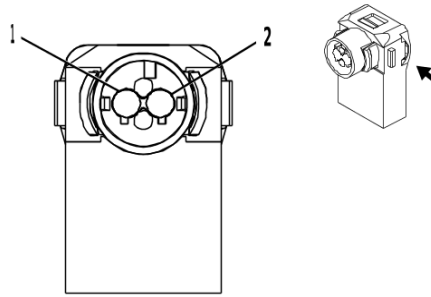

4241364

**Connector Part Information**

Harness Type: Steering Wheel Horn Switch Wiring Harness  
 OEM Connector: 13516029  
 Service Connector: Service by Harness - See Part Catalog  
 Description: 2-Way F ABX-5 Series( PU with YE Cover)

**Terminal Part Information**

Terminal Type ID	Terminated Lead	Diagnostic Test Probe	Terminal Removal Tool
I	Not required	J-35616-10 (GN)	No Tool Required

**F107 Steering Wheel Airbag X2 (NK5 / D07)**

Pin	Size	Color	Circuit	Function	Terminal Type ID	Option
1	0.5	OG / GN	3023	Steering Wheel Air Bag Stage 2 High Control	I	—
2	0.5	WH / OG	3022	Steering Wheel Air Bag Stage 2 Low Control	I	—

**F112D Front Seat Belt Retractor - Driver**

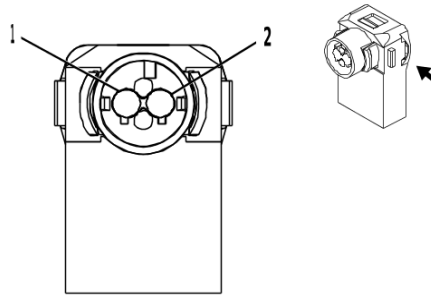

4241364

**Connector Part Information**

Harness Type: Body Wiring Harness  
 OEM Connector: 33345778  
 Service Connector: 85666123  
 Description: 2-Way F ABX-5 Series( PU with YE Cover)

**Terminal Part Information**

Terminal Type ID	Terminated Lead	Diagnostic Test Probe	Terminal Removal Tool
I	Not required	J-35616-10 (GN)	No Tool Required

**F112D Front Seat Belt Retractor - Driver**

Pin	Size	Color	Circuit	Function	Terminal Type ID	Option
1	0.5	OG / WH	3477	Driver Seat Belt Retractor Pretensioner High Control	I	—
2	0.5	VT / OG	3478	Driver Seat Belt Retractor Pretensioner Low Control	I	—

**F112P Front Seat Belt Retractor - Passenger**

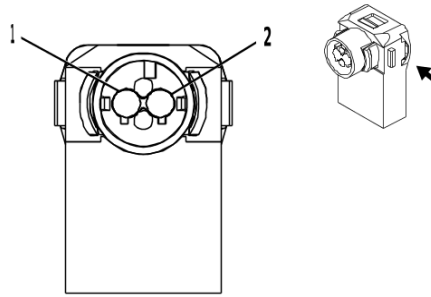

4241364

**Connector Part Information**

Harness Type: Body Wiring Harness  
 OEM Connector: 33345778  
 Service Connector: 85666123  
 Description: 2-Way F ABX-5 Series( PU with YE Cover)

**Terminal Part Information**

Terminal Type ID	Terminated Lead	Diagnostic Test Probe	Terminal Removal Tool
I	Not required	J-35616-10 (GN)	No Tool Required

**F112P Front Seat Belt Retractor - Passenger**

Pin	Size	Color	Circuit	Function	Terminal Type ID	Option
1	0.5	OG / GN	3475	Passenger Seat Belt Retractor Pretensioner High Control	I	—
2	0.5	WH / OG	3476	Passenger Seat Belt Retractor Pretensioner Low Control	I	—

**F113D Front Seat Belt Anchor Plate Tensioner - Driver**

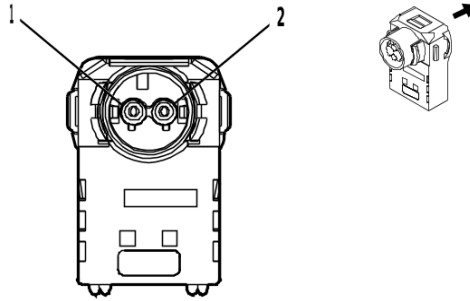

4231869

**Connector Part Information**

Harness Type: Body Wiring Harness  
 OEM Connector: 33345777  
 Service Connector: 85666122  
 Description: 2-Way F ABX-5 Series( PK with YE Cover)

**Terminal Part Information**

Terminal Type ID	Terminated Lead	Diagnostic Test Probe	Terminal Removal Tool
I	Not required	J-35616-10 (GN)	No Tool Required

**F113D Front Seat Belt Anchor Plate Tensioner - Driver**

Pin	Size	Color	Circuit	Function	Terminal Type ID	Option
1	0.5	OG / YE	3481	Driver Seat Belt Anchor Pretensioner High Control	I	—
2	0.5	VT / OG	3482	Driver Seat Belt Anchor Pretensioner Low Control	I	—



**F113P Front Seat Belt Anchor Plate Tensioner - Passenger**

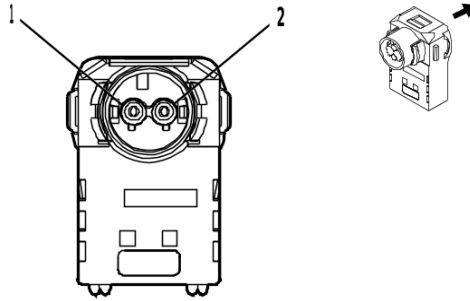

4231869

**Connector Part Information**

Harness Type: Body Wiring Harness  
 OEM Connector: 33345777  
 Service Connector: 85666122  
 Description: 2-Way F ABX-5 Series( PK with YE Cover)

**Terminal Part Information**

Terminal Type ID	Terminated Lead	Diagnostic Test Probe	Terminal Removal Tool
I	Not required	J-35616-10 (GN)	No Tool Required

**F113P Front Seat Belt Anchor Plate Tensioner - Passenger**

Pin	Size	Color	Circuit	Function	Terminal Type ID	Option
1	0.5	OG / BN	3479	Passenger Seat Belt Anchor Pretensioner High Control	I	—
2	0.5	GY / OG	3480	Passenger Seat Belt Anchor Pretensioner Low Control	I	—

**G5 Automatic Transmission Auxiliary Fluid Pump (MHS / MQC)**

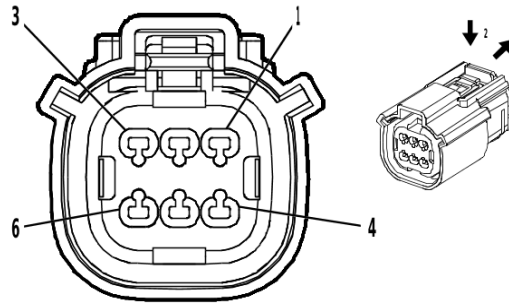

4574736

**Connector Part Information**

Harness Type: Automatic Transmission Wiring Harness - Case  
 OEM Connector: 160038-3009  
 Service Connector: Service by Harness - See Part Catalog  
 Description: 6-Way F 1.5 MX Series, Sealed( WH)

**Terminal Part Information**

Terminal Type ID	Terminated Lead	Diagnostic Test Probe	Terminal Removal Tool
I	Not required	J-35616-2A (GY)	No Tool Required

**G5 Automatic Transmission Auxiliary Fluid Pump (MHS / MQC)**

Pin	Size	Color	Circuit	Function	Terminal Type ID	Option
1	1.5	GN / VT	8540	Battery Positive Voltage	I	—
2	—	—	—	Not Occupied	—	—
3	0.5	BN	6387	Transmission High Side Driver 1 Control	I	—
4	0.5	GY / OG	2968	Transmission Auxiliary Fluid Pump Control	I	—
5	—	—	—	Not Occupied	—	—
6	1.5	BK / YE	450	Ground	I	—

**G5 Automatic Transmission Auxiliary Fluid Pump (MHT / MQB)**

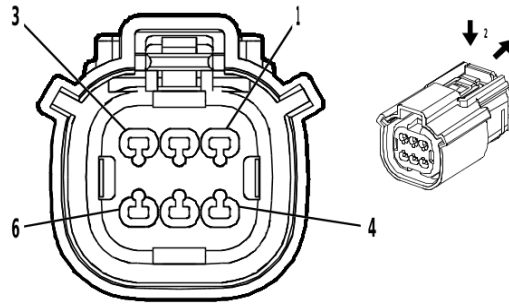

4574736

**Connector Part Information**

Harness Type: Automatic Transmission Wiring Harness - Case  
 OEM Connector: 160038-3009  
 Service Connector: Service by Harness - See Part Catalog  
 Description: 6-Way F 1.5 MX Series, Sealed( WH)

**Terminal Part Information**

Terminal Type ID	Terminated Lead	Diagnostic Test Probe	Terminal Removal Tool
I	Not required	J-35616-2A (GY)	No Tool Required

**G5 Automatic Transmission Auxiliary Fluid Pump (MHT / MQB)**

Pin	Size	Color	Circuit	Function	Terminal Type ID	Option
1	1.5	GN / VT	8540	Battery Positive Voltage	I	—
2	—	—	—	Not Occupied	—	—
3	0.5	BN	6387	Transmission High Side Driver 1 Control	I	—
4	0.5	GY / OG	2968	Transmission Auxiliary Fluid Pump Control	I	—
5	—	—	—	Not Occupied	—	—
6	1.5	BK / YE	450	Ground	I	—

**G8 Engine Coolant Pump - Auxiliary**

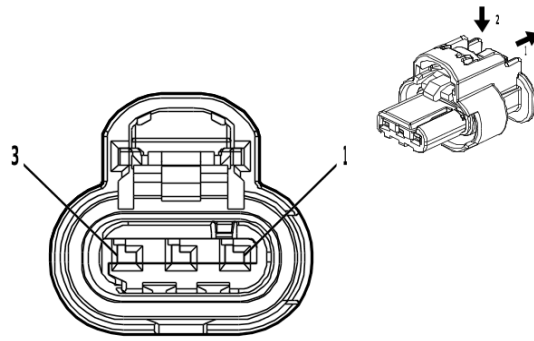

4581126

**Connector Part Information**

Harness Type: Engine Wiring Harness  
 OEM Connector: 1-2296695-1  
 Service Connector: 86792094  
 Description: 3-Way F 1.2 MCON-CB Series, Sealed( BK)

**Terminal Part Information**

Terminal Type ID	Terminated Lead	Diagnostic Test Probe	Terminal Removal Tool
I	Not required	J-35616-16 (L-GN)	No Tool Required

**G8 Engine Coolant Pump - Auxiliary**

Pin	Size	Color	Circuit	Function	Terminal Type ID	Option
1	0.75	BK	450	Ground	I	—
2	0.5	RD / BU	6040	Battery Positive Voltage	I	—
3	0.5	GN / VT	4621	Engine Control Module LIN Bus 1	I	—

### G10L Cooling Fan Motor - Left

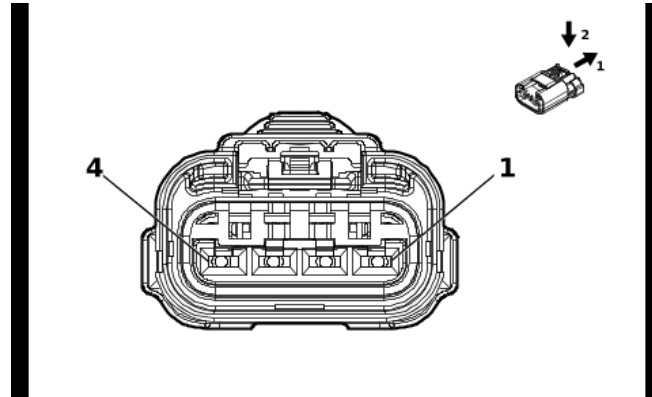

5838592

#### Connector Part Information

Harness Type: Engine Wiring Harness  
 OEM Connector: 35243535  
 Service Connector: 85563415  
 Description: 4-Way F 2.8 APEX Series, Sealed( BK)

#### Terminal Part Information

Terminal Type ID	Terminated Lead	Diagnostic Test Probe	Terminal Removal Tool
I	Not required	J-35616-2A (GY)	No Tool Required
II	Not required	J-35616-35 (VT)	No Tool Required
III	Not required	J-35616-4A (PU)	No Tool Required

#### G10L Cooling Fan Motor - Left

Pin	Size	Color	Circuit	Function	Terminal Type ID	Option
1	5	BK	6550	Ground	III	L3B
	5	BK	450	Ground	III	L84 / L87
	5	BK	4450	Ground	III	LZ0
2	5	RD / GN	3840	Battery Positive Voltage	III	—
3	—	—	—	Not Occupied	—	—
4	0.75	GN / VT	4621	Engine Control Module LIN Bus 1	I	L84/ L87
	0.75	GN / VT	4621	Engine Control Module LIN Bus 1	II	LZ0/ L3B

**G10LW Cooling Fan Motor - Lower**

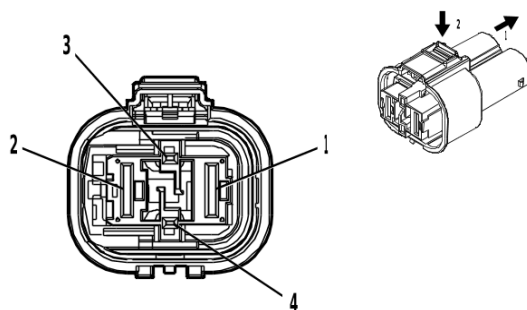

4847569

**Connector Part Information**

Harness Type: Engine Wiring Harness  
 OEM Connector: 4-2286732-1  
 Service Connector: 84766431  
 Description: 4-Way F 1.2, 9.5 MCON Series, Sealed( BK)

**Terminal Part Information**

Terminal Type ID	Terminated Lead	Diagnostic Test Probe	Terminal Removal Tool
I	Not required	J-35616-16 (L-GN)	No Tool Required
II	Not required	J-35616-22 (RD)	No Tool Required

**G10LW Cooling Fan Motor - Lower**

Pin	Size	Color	Circuit	Function	Terminal Type ID	Option
1	5	RD / GY	4140	Battery Positive Voltage	II	—
2	5	BK	6550	Ground	II	L3B
		BK	4450	Ground		LZ0
3	0.5	GN / YE	4623	Engine Control Module LIN Bus 3	I	—
4	—	—	—	Not Occupied	—	—

**G10R Cooling Fan Motor - Right (L3B)**

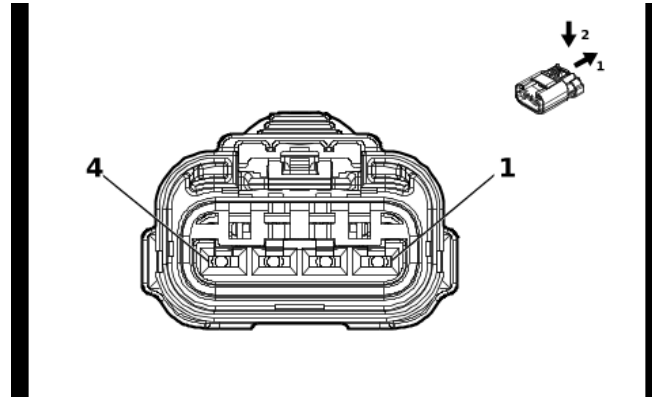

5838592

**Connector Part Information**

Harness Type: Engine Wiring Harness  
 OEM Connector: 35243535  
 Service Connector: 85563415  
 Description: 4-Way F 2.8 APEX Series, Sealed( BK)

**Terminal Part Information**

Terminal Type ID	Terminated Lead	Diagnostic Test Probe	Terminal Removal Tool
I	Not required	J-35616-35 (VT)	No Tool Required
II	Not required	J-35616-4A (PU)	No Tool Required

**G10R Cooling Fan Motor - Right (L3B)**

Pin	Size	Color	Circuit	Function	Terminal Type ID	Option
1	5	BK	6550	Ground	II	—
2	5	RD / VT	4040	Battery Positive Voltage	II	—
3	—	—	—	Not Occupied	—	—
4	0.75	GN / VT	4621	Engine Control Module LIN Bus 1	I	—

**G10R Cooling Fan Motor - Right (L84 / L87)**

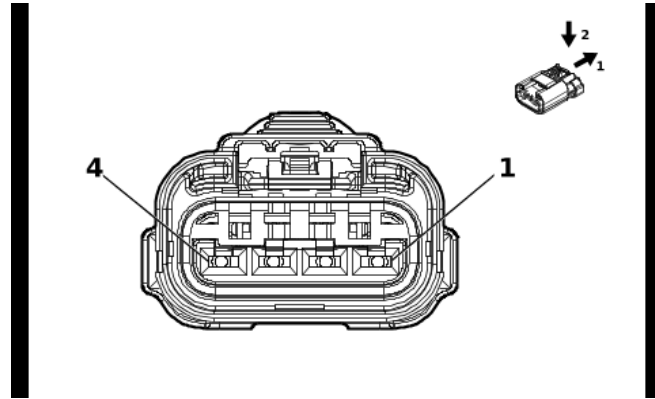

5838592

**Connector Part Information**

Harness Type: Engine Wiring Harness  
 OEM Connector: 35243535  
 Service Connector: 85563415  
 Description: 4-Way F 2.8 APEX Series, Sealed( BK)

**Terminal Part Information**

Terminal Type ID	Terminated Lead	Diagnostic Test Probe	Terminal Removal Tool
I	Not required	J-35616-2A (GY)	No Tool Required
II	Not required	J-35616-4A (PU)	No Tool Required

**G10R Cooling Fan Motor - Right (L84 / L87)**

Pin	Size	Color	Circuit	Function	Terminal Type ID	Option
1	5	BK	450	Ground	II	—
2	5	RD / PU	4040	Battery Positive Voltage	II	—
3	—	—	—	Not Occupied	—	—
4	0.75	GN / VT	4621	Engine Control Module LIN Bus 1	I	—



**G10R Cooling Fan Motor - Right (LZ0)**

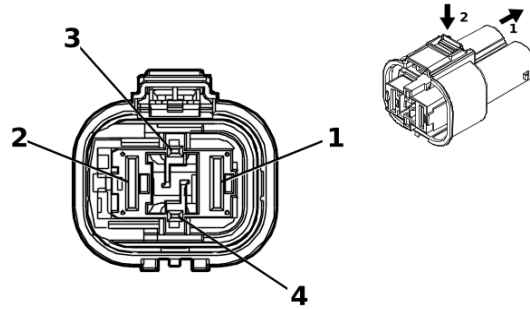

5187743

**Connector Part Information**

Harness Type: Engine Wiring Harness  
 OEM Connector: 4-2286732-2  
 Service Connector: Service by Harness - See Part Catalog  
 Description: 4-Way F 1.2, 9.5 MCON Series( GY)

**Terminal Part Information**

Terminal Type ID	Terminated Lead	Diagnostic Test Probe	Terminal Removal Tool
I	Not required	J-35616-16 (L-GN)	No Tool Required
II	Not required	J-35616-22 (RD)	No Tool Required

**G10R Cooling Fan Motor - Right (LZ0)**

Pin	Size	Color	Circuit	Function	Terminal Type ID	Option
1	8	RD / BN	1742	Battery Positive Voltage	II	—
2	8	BK	4450	Ground	II	—
3	0.5	GN / VT	4621	Engine Control Module LIN Bus 1	I	—
4	—	—	—	Not Occupied	—	—

**G13 Generator X1 (L3B)**

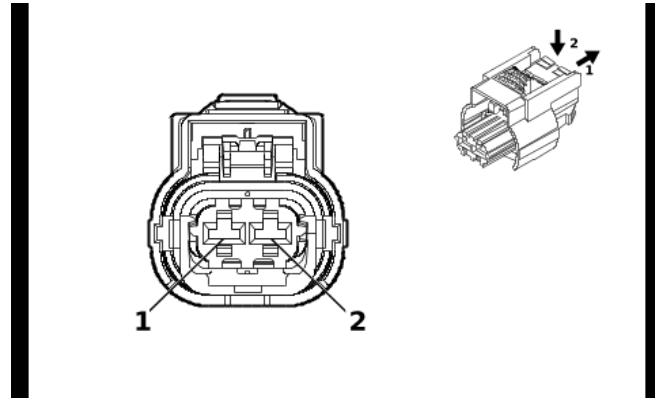

4992524

**Connector Part Information**

Harness Type: Engine Wiring Harness  
 OEM Connector: 35182447  
 Service Connector: 84941154  
 Description: 2-Way F 2.8 MCP Series, Sealed( BK)

**Terminal Part Information**

Terminal Type ID	Terminated Lead	Diagnostic Test Probe	Terminal Removal Tool
I	Not required	J-35616-35 (VT)	No Tool Required

**G13 Generator X1 (L3B)**

Pin	Size	Color	Circuit	Function	Terminal Type ID	Option
1	0.5	BN	25	Charge Indicator Control	I	—
2	0.5	GY	23	Generator Field Duty Cycle Signal	I	—

**G13 Generator X1 (L84 / L87)**

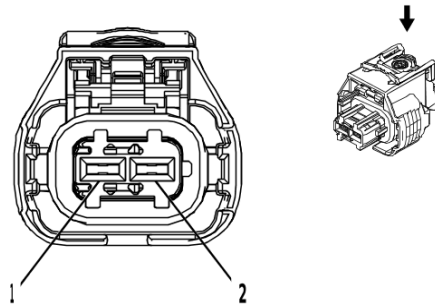

2577394

**Connector Part Information**

Harness Type: Engine Wiring Harness  
 OEM Connector: 1 928 405 714  
 Service Connector: 13384371  
 Description: 2-Way F 2.8 Series, Sealed( BK)

**Terminal Part Information**

Terminal Type ID	Terminated Lead	Diagnostic Test Probe	Terminal Removal Tool
I	Not required	J-35616-35 (VT)	No Tool Required

**G13 Generator X1 (L84 / L87)**

Pin	Size	Color	Circuit	Function	Terminal Type ID	Option
1	0.5	BN	25	Charge Indicator Control	I	—
2	0.5	GY	23	Generator Field Duty Cycle Signal	I	—

**G13 Generator X1 (LZ0)**

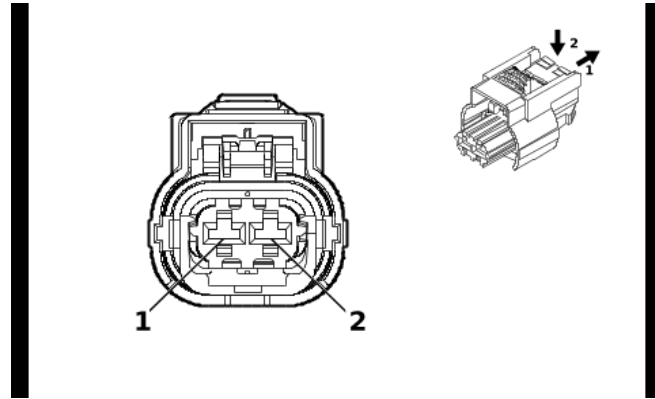

4992524

**Connector Part Information**

Harness Type: Engine Wiring Harness  
 OEM Connector: 35182447  
 Service Connector: 84941154  
 Description: 2-Way F 2.8 MCP Series, Sealed( BK)

**Terminal Part Information**

Terminal Type ID	Terminated Lead	Diagnostic Test Probe	Terminal Removal Tool
I	Not required	J-35616-35 (VT)	No Tool Required

**G13 Generator X1 (LZ0)**

Pin	Size	Color	Circuit	Function	Terminal Type ID	Option
1	0.5	BN	25	Charge Indicator Control	I	—
2	0.5	GY	23	Generator Field Duty Cycle Signal	I	—

**G13 Generator X1 (VYU)**

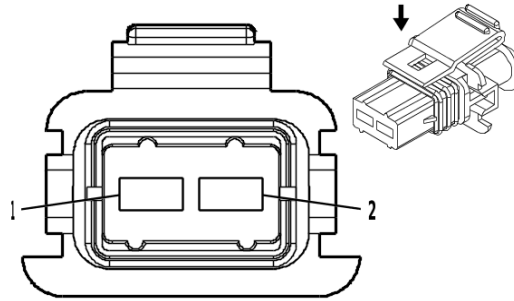

1522871

**Connector Part Information**

Harness Type: Accessory Wiring Harness  
 OEM Connector: 12186308  
 Service Connector: Service by Harness - See Part Catalog  
 Description: 2-Way F Junior Power Timer Series, Sealed( BK)

**Terminal Part Information**

Terminal Type ID	Terminated Lead	Diagnostic Test Probe	Terminal Removal Tool
I	Not required	J-35616-35 (VT)	No Tool Required

**G13 Generator X1 (VYU)**

Pin	Size	Color	Circuit	Function	Terminal Type ID	Option
1	0.5	BN	9025	Charge Indicator Control Switch Signal	I	—
2	0.5	GY	23	Generator Field Duty Cycle Signal	I	—

**G13 Generator X2 (L3B)**

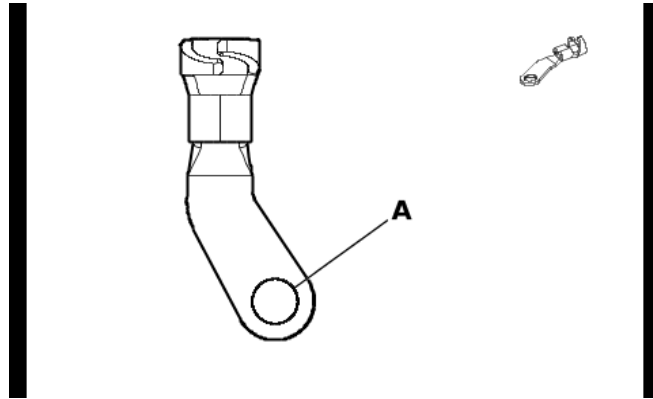

5911279

**Connector Part Information**

Harness Type: Starter Solenoid Cable  
 OEM Connector: 84238913  
 Service Connector: Service by Cable Assembly — See Part Catalog  
 Description: 1-Way Ring Terminal

**Terminal Part Information**

Terminal Type ID	Terminated Lead	Diagnostic Test Probe	Terminal Removal Tool
I	Not required	No Tool Required	No Tool Required

**G13 Generator X2 (L3B)**

Pin	Size	Color	Circuit	Function	Terminal Type ID	Option
A	35	RD / BU	42	Battery Positive Voltage	I	—

## G13 Generator X2 (L84 / L87)

—

### Connector Part Information

Harness Type: Starter Solenoid Cable  
 OEM Connector: 84223343  
 Service Connector: Service by Cable Assembly — See Part Catalog  
 Description: 1-Way F Ring Terminal

### Terminal Part Information

Terminal Type ID	Terminated Lead	Diagnostic Test Probe	Terminal Removal Tool
I	Not required	No Tool Required	No Tool Required

### G13 Generator X2 (L84 / L87)

Pin	Size	Color	Circuit	Function	Terminal Type ID	Option
A	35	RD / BU	42	Battery Positive Voltage	I	—

**G13 Generator X2 (LZ0)**

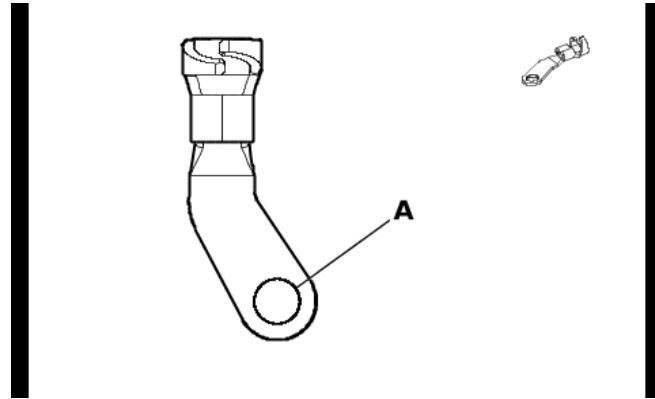

5911279

**Connector Part Information**

Harness Type: Starter Solenoid Cable  
 OEM Connector: 84238913  
 Service Connector: Service by Cable Assembly — See Part Catalog  
 Description: 1-Way Ring Terminal

**Terminal Part Information**

Terminal Type ID	Terminated Lead	Diagnostic Test Probe	Terminal Removal Tool
I	Not required	No Tool Required	No Tool Required

**G13 Generator X2 (LZ0)**

Pin	Size	Color	Circuit	Function	Terminal Type ID	Option
A	35	RD / BU	42	Battery Positive Voltage	I	—



**G18 Fuel Pump - High Pressure (L3B)**

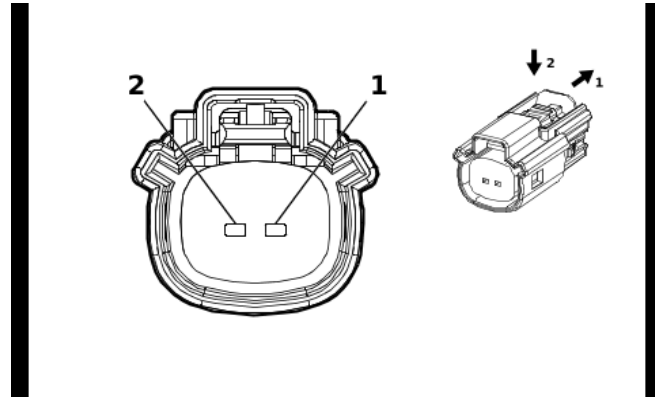

2474713

**Connector Part Information**

Harness Type: Engine Wiring Harness  
 OEM Connector: 33471-0206  
 Service Connector: 13577534  
 Description: 2-Way F 1.5 Series, Sealed( BK)

**Terminal Part Information**

Terminal Type ID	Terminated Lead	Diagnostic Test Probe	Terminal Removal Tool
I	Not required	J-35616-14 (GN)	No Tool Required

**G18 Fuel Pump - High Pressure (L3B)**

Pin	Size	Color	Circuit	Function	Terminal Type ID	Option
1	0.5	VT / BK	7300	High Pressure Fuel Pump Low Control	I	—
2	0.5	YE	7301	High Pressure Fuel Pump High Control	I	—

**G18 Fuel Pump - High Pressure (L84 / L87)**

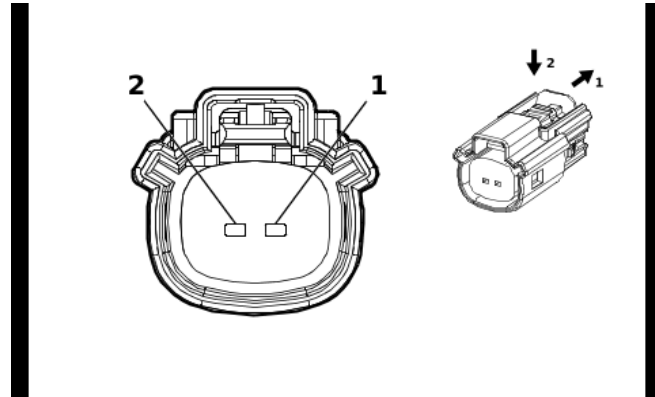

2474713

**Connector Part Information**

Harness Type: Fuel Injector Wiring Harness - Bank 2  
 OEM Connector: 33471-0206  
 Service Connector: Service by Harness - See Part Catalog  
 Description: 2-Way F 1.5 Series, Sealed( BK)

**Terminal Part Information**

Terminal Type ID	Terminated Lead	Diagnostic Test Probe	Terminal Removal Tool
I	Not required	J-35616-14 (GN)	No Tool Required

**G18 Fuel Pump - High Pressure (L84 / L87)**

Pin	Size	Color	Circuit	Function	Terminal Type ID	Option
1	0.8	VT / BK	7300	High Pressure Fuel Pump Low Control	I	—
2	0.8	YE	7301	High Pressure Fuel Pump High Control	I	—

## G24 Windshield Washer Pump

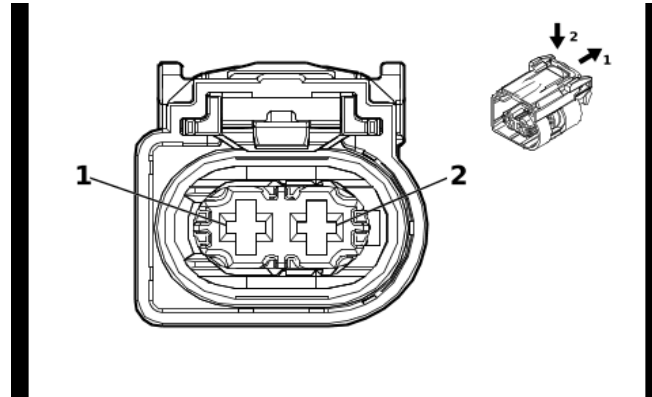

5580410

### Connector Part Information

Harness Type: Body Wiring Harness  
 OEM Connector: 2425741-1  
 Service Connector: 85005016  
 Description: 2-Way F 2.8 MCP Series, Sealed( BK)

### Terminal Part Information

Terminal Type ID	Terminated Lead	Diagnostic Test Probe	Terminal Removal Tool
I	Not required	J-35616-4A (PU)	No Tool Required

### G24 Windshield Washer Pump

Pin	Size	Color	Circuit	Function	Terminal Type ID	Option
1	0.75	GY / VT	228	Windshield Washer Pump Control	I	—
2	0.75	BK	150	Ground	I	—

**G58 Evaporative Emission Canister Purge Pump**

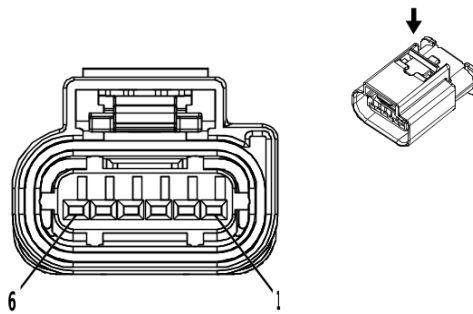

3747579

**Connector Part Information**

Harness Type: Engine Wiring Harness  
 OEM Connector: 2272975-1  
 Service Connector: 19354437  
 Description: 6-Way F 1.2 MCON Series, Sealed( BK)

**Terminal Part Information**

Terminal Type ID	Terminated Lead	Diagnostic Test Probe	Terminal Removal Tool
I	Not required	J-35616-12 (BU)	No Tool Required

**G58 Evaporative Emission Canister Purge Pump**

Pin	Size	Color	Circuit	Function	Terminal Type ID	Option
1	0.5	BN / BU	2447	Evaporative Purge Pump Pressure Signal	I	—
2	0.5	BK / YE	548	Engine Control Sensors Low Reference 1	I	—
3	0.5	BU / RD	460	Engine Control Sensors 5 Volt Reference 1	I	—
4	0.5	GN / BN	2732	Engine Control Module LIN Bus 4	I	—
5	0.75	BK	6550	Ground	I	—
6	0.75	VT / BU	5294	Powertrain Main Relay Fused Supply Voltage 5	I	—

## G59 Engine Coolant Pump

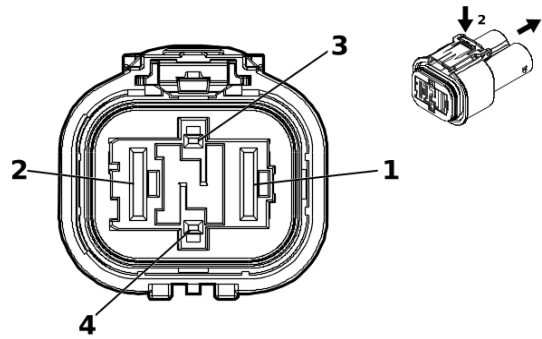

5389785

### Connector Part Information

Harness Type: Engine Wiring Harness  
 OEM Connector: 1-2332470-1  
 Service Connector: Service by Harness - See Part Catalog  
 Description: 4-Way F 1.2, 9.5 MCON Series( BK)

### Terminal Part Information

Terminal Type ID	Terminated Lead	Diagnostic Test Probe	Terminal Removal Tool
I	Not required	J-35616-12 (BU)	No Tool Required
II	Not required	J-35616-22 (RD)	No Tool Required

### G59 Engine Coolant Pump

Pin	Size	Color	Circuit	Function	Terminal Type ID	Option
1	10	RD / BN	1742	Battery Positive Voltage	II	—
2	10	BK	6550	Ground	II	—
3	0.5	GN / BN	2732	Engine Control Module LIN Bus 4	I	—
4	—	—	—	Not Occupied	—	—

**K4 Running Board Control Module X1 (BRS)**

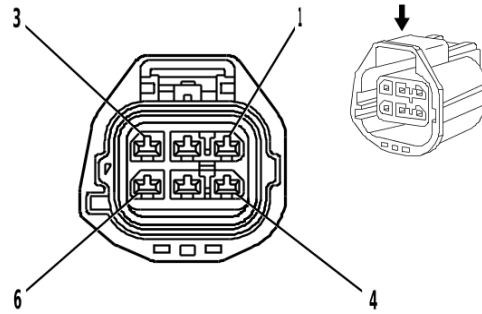

1420587

**Connector Part Information**

Harness Type: Chassis Wiring Harness  
 OEM Connector: 7287-9814-10  
 Service Connector: 19368306  
 Description: 6-Way F 2.8 Series, Sealed( GY)

**Terminal Part Information**

Terminal Type ID	Terminated Lead	Diagnostic Test Probe	Terminal Removal Tool
I	Not required	J-35616-35 (VT)	No Tool Required

**K4 Running Board Control Module X1 (BRS)**

Pin	Size	Color	Circuit	Function	Terminal Type ID	Option
1	2.5	RD / WH	1040	Battery Positive Voltage	I	—
2	2	GY	7472	Left Running Board Step Motor Control Retract	I	—
3	2	BU	7470	Right Running Board Step Motor Control Extend	I	—
4	2.5	BK	1650	Ground	I	—
5	2	WH / BN	7471	Left Running Board Step Motor Control Extend	I	—
6	2	GN	7469	Right Left Running Board Step Motor Control Retract	I	—

## K4 Running Board Control Module X2 (BRS)

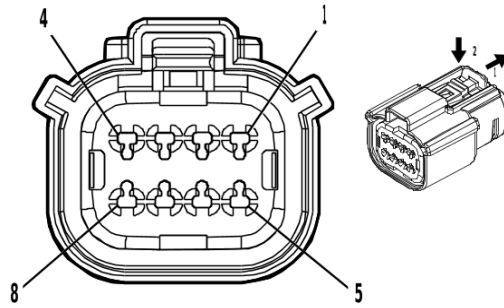

4846407

### Connector Part Information

Harness Type: Chassis Wiring Harness  
 OEM Connector: 33472-4816  
 Service Connector: 84928314  
 Description: 8-Way F 1.5 MX Series, Sealed( BK)

### Terminal Part Information

Terminal Type ID	Terminated Lead	Diagnostic Test Probe	Terminal Removal Tool
I	Not required	J-35616-2A (GY)	No Tool Required

### K4 Running Board Control Module X2 (BRS)

Pin	Size	Color	Circuit	Function	Terminal Type ID	Option
1	0.5	WH	4986	AUTOSAR CAN Bus [-] 1 Serial Data	I	—
2	0.5	WH	4986	AUTOSAR CAN Bus [-] 1 Serial Data	I	—
3	0.5	BU	4987	AUTOSAR CAN Bus [+] 1 Serial Data	I	—
4	—	—	—	Not Occupied	—	—
5	0.5	BU	4987	AUTOSAR CAN Bus [+] 1 Serial Data	I	—
6	0.5	WH	4986	AUTOSAR CAN Bus [-] 1 Serial Data	I	—
7	0.5	BU	4987	AUTOSAR CAN Bus [+] 1 Serial Data	I	—
8	—	—	—	Not Occupied	—	—

**K4 Running Board Control Module X3 (BRS)**

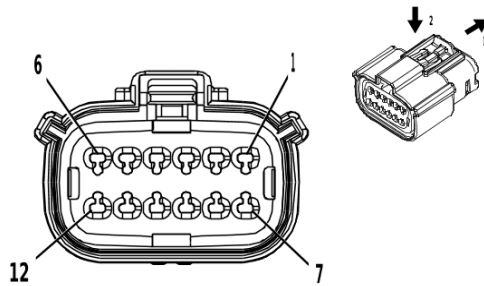

2871860

**Connector Part Information**

Harness Type: Chassis Wiring Harness  
 OEM Connector: 35554985  
 Service Connector: 19352907  
 Description: 12-Way F 1.5 MX Series, Sealed( BK)

**Terminal Part Information**

Terminal Type ID	Terminated Lead	Diagnostic Test Probe	Terminal Removal Tool
I	19368973	J-35616-2A (GY)	J-38125-217

**K4 Running Board Control Module X3 (BRS)**

Pin	Size	Color	Circuit	Function	Terminal Type ID	Option
1	0.5	GN / RD	7464	Right Running Board Step Motor Hall Sensor 5V Reference	I	—
2	0.5	VT	7465	Right Running Board Step Motor Hall Sensor Signal	I	—
3	0.5	YE / BK	7463	Right Running Board Step Motor Hall Sensor Low Reference	I	—
4 - 6	—	—	—	Not Occupied	—	—
7	0.5	VT / RD	7468	Left Running Board Step Motor Hall Sensor 5V Reference	I	—
8	0.5	YE	7467	Left Running Board Step Motor Hall Sensor Signal	I	—
9	0.5	YE / BN	7466	Left Running Board Step Motor Hall Sensor Low Reference	I	—
10	0.5	BU / GN	4746	Running Board Step Left Kick Switch Signal	I	—
11	0.5	WH	4747	Running Board Step Right Kick Switch Signal	I	—
12	—	—	—	Not Occupied	—	—



### K9 Body Control Module X1

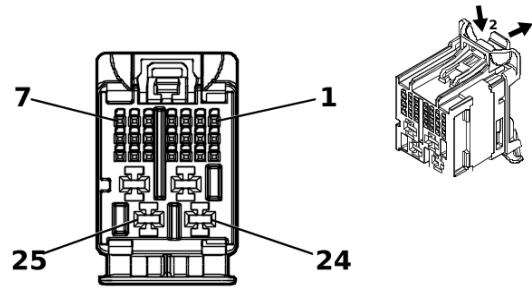

5203995

#### Connector Part Information

Harness Type: Instrument Panel Wiring Harness  
 OEM Connector: 160027-0013  
 Service Connector: 13534967  
 Description: 25-Way F 0.5 MQS, 2.8 MCP Series( BK with GY Inner Connector)

#### Terminal Part Information

Terminal Type ID	Terminated Lead	Diagnostic Test Probe	Terminal Removal Tool
I	19370262	EL-35616-58 (BK)	EL-38125-58
II	87814662	J-35616-4A (PU)	J-38125-557

#### K9 Body Control Module X1

Pin	Size	Color	Circuit	Function	Terminal Type ID	Option
1	—	—	—	Not Occupied	—	—
2	0.35	BU / GN	4248	Cargo Lamp Indicator Control	I	—
3 - 4	—	—	—	Not Occupied	—	—
5	0.35	BU / GY	754	Blower Motor Speed Control	I	—
6	0.35	WH / YE	4634	HVAC Remote Enable Signal	I	—
7	0.35	WH / GY	7297	Minor Endgate High Relay Control	I	—
8 - 10	—	—	—	Not Occupied	—	—
11	0.35	GY / GN	4636	HVAC System Enable Signal	I	—
12	0.35	GY	728	Security Indicator Control	I	—
13	0.35	YE	6812	Out of Park Signal	I	—
14	—	—	—	Not Occupied	—	—
15	0.35	GY	590	Driver Solar Sensor Signal	I	—
16	0.35	GY	6137	Air Conditioning Evaporator Temperature Sensor Signal	I	—
17	0.35	WH / BU	278	Ambient Light Sensor Signal	I	—
18	0.35	BU / WH	734	Inside Air Temperature Sensor Signal	I	—
19	0.35	GY	158	Cargo Lamp Switch Signal	I	—
20	0.35	GN / VT	2852	Body Control Module LIN Bus 6	I	—
21 - 22	—	—	—	Not Occupied	—	—
23	1	RD / GY	2140	Battery Positive Voltage	II	—
24	—	—	—	Not Occupied	—	—

**6-348 Electrical Component and Inline Harness Connector End Views**

---

**K9 Body Control Module X1 (cont'd)**

<b>Pin</b>	<b>Size</b>	<b>Color</b>	<b>Circuit</b>	<b>Function</b>	<b>Terminal Type ID</b>	<b>Option</b>
25	1	GN / YE	6840	Auxiliary Device 2 Switched Voltage	II	—

## K9 Body Control Module X2

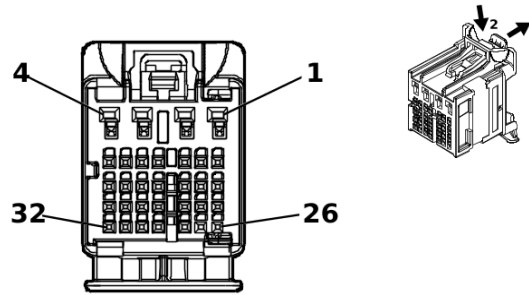

5204222

### Connector Part Information

Harness Type: Instrument Panel Wiring Harness

OEM Connector: 160028-0015

Service Connector: 13534980

Description: 32-Way F 0.5 NANO, 1.2 MCON, stAK50h Series( PK with GY Inner Connector)

### Terminal Part Information

Terminal Type ID	Terminated Lead	Diagnostic Test Probe	Terminal Removal Tool
I	19370262	EL-35616-58 (BK)	EL-38125-58

### K9 Body Control Module X2

Pin	Size	Color	Circuit	Function	Terminal Type ID	Option
1 - 4	—	—	—	Not Occupied	—	—
5	0.35	BU / GN	5723	Ignition Mode Switch Mode Voltage	I	—
6 - 8	—	—	—	Not Occupied	—	—
9	0.35	VT / YE	5526	Tap Up/Tap Down Switch Signal	I	( MQC/ MHS) + N38 MQE/ MQB/ MHT
	0.35	GN / BU	3738	Tap Up/Tap Down Switch Signal 2	I	
10	0.35	WH / BN	2203	Enhanced Driver Mode 2 Switch Signal	I	—
11	0.35	GY	1198	Endgate Release Switch Analog Signal Interior	I	—
12	0.35	YE / BU	1714	Windshield Wiper Switch Low Signal	I	—
13	0.35	GY / GN	5737	Distance Sensing Cruise Control Gap Up/Down Switch Signal	I	—
14	0.35	BN / GN	1884	Cruise Control Set/Coast/Resume/Accelerate Switch Signal	I	—
15	—	—	—	Not Occupied	—	—
16	0.35	BN / BK	5720	Ignition Mode Switch Accessory LED Signal	I	—
17 - 18	—	—	—	Not Occupied	—	—
19	0.35	WH / VT	103	Headlamp Switch On Signal	I	—
20	0.35	GN / GY	13	Headlamp Switch Park Lamp Signal	I	—
21	0.35	GN / BN	306	Headlamp Switch Off Signal	I	—
22	—	—	—	Not Occupied	—	—
23	0.35	VT / BU	2916	Right Turn Signal Switch Signal	I	—
24	—	—	—	Not Occupied	—	—

**6-350 Electrical Component and Inline Harness Connector End Views****K9 Body Control Module X2 (cont'd)**

<b>Pin</b>	<b>Size</b>	<b>Color</b>	<b>Circuit</b>	<b>Function</b>	<b>Terminal Type ID</b>	<b>Option</b>
25	0.35	BK / GY	6009	Windshield Wiper Switch Low Reference	I	—
26	0.35	WH / BK	94	Windshield Washer Switch Signal	I	—
27	0.35	YE / BN	307	Headlamp Switch Flash Signal	I	—
28	0.35	GN / WH	3287	Horn Switch Signal	I	—
29	0.35	WH / GN	2915	Left Turn Signal Switch Signal	I	—
30	0.35	BK / YE	407	Sensor Low Reference	I	—
31	0.35	GN / WH	111	Hazard Warning Switch Signal	I	—
32	0.35	WH	524	High Beam Select Switch High Beam Signal	I	—

### K9 Body Control Module X3

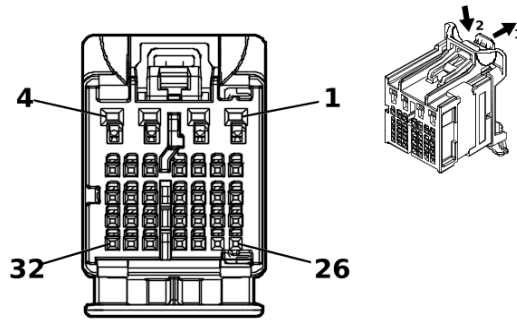

5203925

#### Connector Part Information

Harness Type: Instrument Panel Wiring Harness  
 OEM Connector: 160028-0012  
 Service Connector: 13534977  
 Description: 32-Way F 0.5 NANO, 1.2 MCON, stAK50h Series( BU with GY Inner Connector)

#### Terminal Part Information

Terminal Type ID	Terminated Lead	Diagnostic Test Probe	Terminal Removal Tool
I	19370262	EL-35616-58 (BK)	EL-38125-58
II	84729890	J-35616-12 (BU)	J-38125-215A

#### K9 Body Control Module X3

Pin	Size	Color	Circuit	Function	Terminal Type ID	Option
1 - 2	—	—	—	Not Occupied	—	—
3	0.35	GN / VT	4786	Dome/Reading Lamp Enable Signal	II	—
4 - 6	—	—	—	Not Occupied	—	—
7	0.35	WH / BN	7555	Headlamp Switch Signal	I	—
8 - 9	—	—	—	Not Occupied	—	—
10	0.35	GN / BK	2858	Body Control Module LIN Bus 12	I	—
11	—	—	—	Not Occupied	—	—
12	0.35	YE / WH	816	Brake Transmission Shift Interlock Solenoid Actuator Control	I	—
13	0.35	WH	3152	Lane Departure Warning Indicator Control	I	—
14	0.35	GN / BN	5852	Rear Parking Assist Disable LED Signal	I	—
15	0.35	GN	1110	Stop/Start Indicator Control	I	—
16	0.35	GN / BU	761	Blower Speed Feedback Signal	I	—
17	0.35	VT / BK	7553	Park Lock Solenoid Actuator Control	I	—
18	0.35	YE	7556	Headlamp Switch Reference	I	—
19	0.35	BU / BK	5719	Ignition Mode Switch Start LED Signal	I	—
20	—	—	—	Not Occupied	—	—
21	0.35	BN	7291	Major Endgate Release Switch Signal Interior	I	—
22	—	—	—	Not Occupied	—	—
23	0.35	BU	1111	Stop/Start Switch Signal	I	—
24	0.35	WH / BU	3691	Trailer Brake Apply Signal	I	—

**6-352 Electrical Component and Inline Harness Connector End Views****K9 Body Control Module X3 (cont'd)**

Pin	Size	Color	Circuit	Function	Terminal Type ID	Option
25	0.35	BU / GY	4990	Driver Mode 1 Switch Signal	I	—
26	0.35	GY / BN	3904	Auto High Beam Assist Switch Signal	I	—
27	0.35	GY / WH	3153	Lane Departure Warning Disable Switch Signal	I	—
28 - 29	—	—	—	Not Occupied	—	—
30	0.35	BU / YE	6844	ABS/Traction Control Hill Descent Control Switch Signal	I	—
31	0.35	GY / GN	2555	Rear Parking Assist Disable Signal	I	—
32	—	—	—	Not Occupied	—	—

## K9 Body Control Module X4

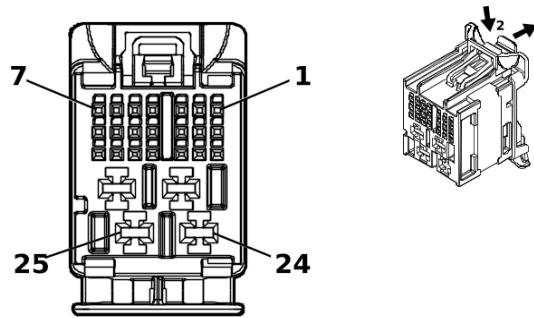

5203893

### Connector Part Information

Harness Type: Instrument Panel Wiring Harness  
 OEM Connector: 160027-0018  
 Service Connector: 13534970  
 Description: 25-Way F 0.5 MQS, 2.8 MCP Series( GY)

### Terminal Part Information

Terminal Type ID	Terminated Lead	Diagnostic Test Probe	Terminal Removal Tool
I	19370262	EL-35616-58 (BK)	EL-38125-58
II	87814662	J-35616-4A (PU)	J-38125-557

### K9 Body Control Module X4

Pin	Size	Color	Circuit	Function	Terminal Type ID	Option
1	0.35	BN / BK	3552	Interior Passive Entry Antenna 1 High Signal	I	—
2	0.35	WH	3553	Interior Passive Entry Antenna 1 Low Signal	I	—
3	0.35	BK / VT	1449	Steering Wheel Resistor Ladder Low Reference	I	—
4	0.35	WH / GN	7728	Major Endgate High Relay Control	I	—
5	0.35	GN / VT	5199	Run/Crank Relay Coil Control	I	—
6	—	—	—	Not Occupied	—	—
7	0.35	BN / BK	4996	Immobilizer Antenna Signal [+]	I	—
8 - 9	—	—	—	Not Occupied	—	—
10	0.35	GY / GN	4083	Retained Accessory Power Relay 2 Coil Control	I	—
11	0.35	BU / YE	7176	All Windows Open Switch Signal	I	—
12	0.35	BU / VT	7729	Major Endgate Low Relay Control	I	—
13	—	—	—	Not Occupied	—	—
14	0.35	WH / GY	4997	Immobilizer Antenna Low Signal	I	—
15	0.35	BU / VT	1788	Traction Control Switch Signal 1	I	—
16	0.35	GN / WH	4115	Body Control Module LIN Bus 5	I	—
17 - 18	—	—	—	Not Occupied	—	—
19	0.35	BU / GN	4979	AUTOSAR CAN Bus [+] <sup>2</sup> Serial Data	I	—
20	0.35	WH / BN	4978	AUTOSAR CAN Bus [-] <sup>2</sup> Serial Data	I	—
21	0.35	WH	6816	Indicator Dimming Control	I	—
22	0.5	RD / WH	2740	Battery Positive Voltage	II	—
23	2	RD / BU	2540	Battery Positive Voltage	II	—

**6-354 Electrical Component and Inline Harness Connector End Views**

---

**K9 Body Control Module X4 (cont'd)**

<b>Pin</b>	<b>Size</b>	<b>Color</b>	<b>Circuit</b>	<b>Function</b>	<b>Terminal Type ID</b>	<b>Option</b>
24	1	BK	1050	Ground	II	—
25	1	BK	1050	Ground	II	—



### K9 Body Control Module X5

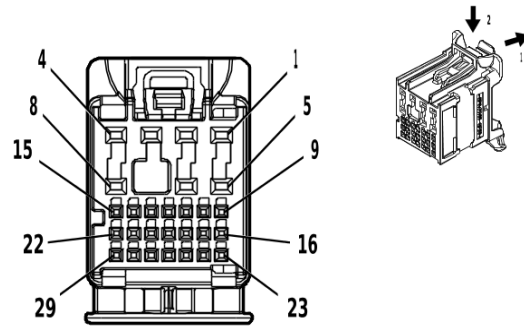

4584346

#### Connector Part Information

Harness Type: Body Wiring Harness  
 OEM Connector: 160014-0012  
 Service Connector: 13534972  
 Description: 29-Way F 0.5 NANO, 1.2 MCON Series( GN)

#### Terminal Part Information

Terminal Type ID	Terminated Lead	Diagnostic Test Probe	Terminal Removal Tool
I	19370262	EL-35616-58 (BK)	EL-38125-58
II	84729890	J-35616-12 (BU)	J-38125-215A

#### K9 Body Control Module X5

Pin	Size	Color	Circuit	Function	Terminal Type ID	Option
1	—	—	—	Not Occupied	—	—
2	0.5	BU / BN	7573	Air Conditioning Compressor Solenoid Valve Control	II	—
3	0.5	BU / YE	7574	Air Conditioning Compressor Solenoid Valve Control	II	—
4	0.75	WH	2679	Lock Actuators Unlock Control 1	II	—
5	—	—	—	Not Occupied	—	—
6	0.5	YE	6817	LED Backlight Dimming Control 1	II	—
7	—	—	—	Not Occupied	—	—
8	0.75	GY	2681	Left Front Door Lock Actuator Lock Control	II	—
9 - 10	—	—	—	Not Occupied	—	—
11	0.35	BN / WH	28	Horn Relay Control	I	—
12	0.35	WH	4978	AUTOSAR CAN Bus [-] 2 Serial Data	I	—
13	0.35	BU / YE	4979	AUTOSAR CAN Bus [+] 2 Serial Data	I	—
14 - 15	—	—	—	Not Occupied	—	—
16	0.35	VT	4301	Passive Entry Left Antenna Signal High	I	—
17	0.35	GN / YE	2855	Body Control Module LIN Bus 9	I	—
18	0.35	VT / GY	126	Left Front Door Open Switch Signal	I	—
19	0.35	GN / YE	6134	Body Control Module LIN Bus 3	I	—
20	—	—	—	Not Occupied	—	—
21	0.35	WH / BU	6311	Cruise/ETC/TCC Brake Signal	I	—
22	0.35	BN / VT	193	Rear Defogger Relay Control	I	—

**6-356 Electrical Component and Inline Harness Connector End Views****K9 Body Control Module X5 (cont'd)**

Pin	Size	Color	Circuit	Function	Terminal Type ID	Option
23	0.35	VT / GY	4302	Passive Entry Left Antenna Signal Low	I	—
24	0.35	WH	5359	Brake Apply Sensor Control	I	—
25	0.35	BU / YE	5361	Brake Apply Sensor Signal	I	—
26	0.35	BK / BN	5360	Brake Apply Sensor Low Reference	I	—
27	0.35	YE	1144	Endgate Release Switch Discrete Signal Exterior	I	—
28 - 29	—	—	—	Not Occupied	—	—

## K9 Body Control Module X6

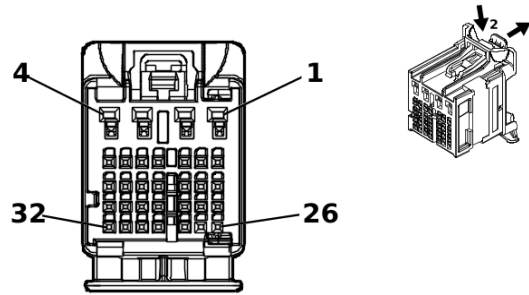

5202291

### Connector Part Information

Harness Type: Body Wiring Harness

OEM Connector: 160028-0017

Service Connector: 13534981

Description: 32-Way F 0.5 MQS, 1.2 OCS Series( BN with GY Inner Connector)

### Terminal Part Information

Terminal Type ID	Terminated Lead	Diagnostic Test Probe	Terminal Removal Tool
I	19370262	EL-35616-58 (BK)	EL-38125-58
II	84729890	J-35616-12 (BU)	J-38125-215A

### K9 Body Control Module X6

Pin	Size	Color	Circuit	Function	Terminal Type ID	Option
1	—	—	—	Not Occupied	—	—
2	0.75	VT / WH	1094	Right Rear Door Lock Actuator Lock Control	II	—
3	0.75	GY / BK	2680	Lock Actuators Unlock Control 2	II	—
4 - 6	—	—	—	Not Occupied	—	—
7	0.35	BN / GN	3568	Rear Closure Passive Entry Antenna High Signal	I	—
8	0.35	GN / GY	3569	Rear Closure Passive Entry Antenna Low Signal	I	—
9 - 10	—	—	—	Not Occupied	—	—
11	0.35	GN / BU	6133	Body Control Module LIN Bus 2	I	—
12	0.35	GY	7292	Major Endgate Release Switch Signal Exterior	I	—
13	—	—	—	Not Occupied	—	—
14	0.35	VT	801	Retained Accessory Power Control	I	—
15 - 18	—	—	—	Not Occupied	—	—
19	0.35	YE	7294	Minor Endgate Release Switch Discrete Signal Exterior	I	—
20	—	—	—	Not Occupied	—	—
21	0.35	YE / BU	7295	Left Minor Endgate Ajar Signal	I	—
22	0.35	BN / GN	4064	Hood Status B Signal	I	—
23 - 27	—	—	—	Not Occupied	—	—
28	0.35	BU	2675	Left Front Exterior Door Handle Switch Unlock Signal	I	—
29 - 32	—	—	—	Not Occupied	—	—

**K9 Body Control Module X7**

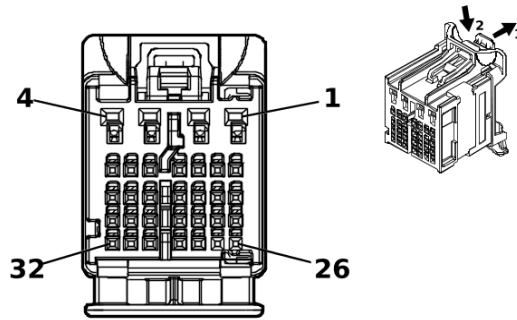

5202294

**Connector Part Information**

Harness Type: Body Wiring Harness

OEM Connector: 160028-0014

Service Connector: 13534979

Description: 32-Way F 0.5 MQS, 1.2 OCS Series( PU with GY Inner Connector)

**Terminal Part Information**

Terminal Type ID	Terminated Lead	Diagnostic Test Probe	Terminal Removal Tool
I	19370262	EL-35616-58 (BK)	EL-38125-58

**K9 Body Control Module X7**

Pin	Size	Color	Circuit	Function	Terminal Type ID	Option
1 - 8	—	—	—	Not Occupied	—	—
9	0.35	YE	900	Not Used	I	—
10 - 18	—	—	—	Not Occupied	—	—
19	0.35	GN / VT	2857	Body Control Module LIN Bus 11	I	—
20	0.35	YE	901	Not Used	I	—
21	—	—	—	Not Occupied	—	—
22	0.35	YE	902	Not Used	I	—
23 - 32	—	—	—	Not Occupied	—	—

## K9 Body Control Module X8

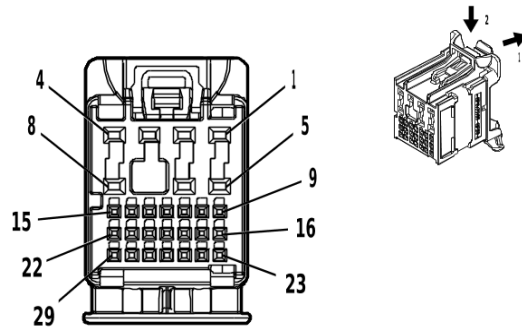

4578560

### Connector Part Information

Harness Type: Body Wiring Harness  
 OEM Connector: 160014-0011  
 Service Connector: 13534971  
 Description: 29-Way F 0.5 NANO, 1.2 MCON, stAK50h Series( GY)

### Terminal Part Information

Terminal Type ID	Terminated Lead	Diagnostic Test Probe	Terminal Removal Tool
I	19370262	EL-35616-58 (BK)	EL-38125-58
II	84729890	J-35616-12 (BU)	J-38125-215A

### K9 Body Control Module X8

Pin	Size	Color	Circuit	Function	Terminal Type ID	Option
1 - 2	—	—	—	Not Occupied	—	—
3	0.75	BU / YE	1091	Left Rear Door Lock Actuator Lock Control	II	—
4	0.75	YE / GN	2682	Right Front Door Lock Actuator Lock Control	II	—
5 - 8	—	—	—	Not Occupied	—	—
9	0.35	GN / BK	4304	Passive Entry Right Antenna Signal Low	I	—
10	0.35	GN / YE	4303	Passive Entry Right Antenna Signal High	I	—
11 - 16	—	—	—	Not Occupied	—	—
17	0.35	GN / YE	2862	Body Control Module LIN Bus 16	I	—
18	0.35	GN / WH	2854	Body Control Module LIN Bus 8	I	—
19 - 27	—	—	—	Not Occupied	—	—
28	0.35	GY / VT	2676	Right Front Door Exterior Switch Unlock Signal	I	—
29	0.35	GN / GY	6135	Body Control Module LIN Bus 4	I	—

**K19 Suspension Control Module (Z45)**

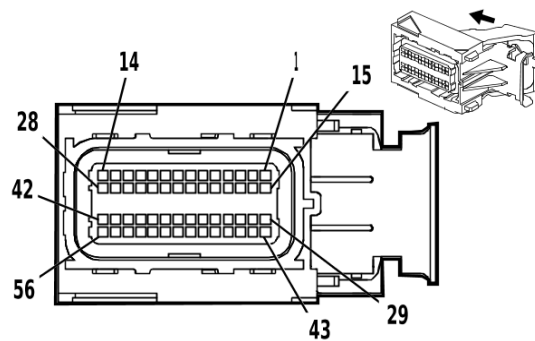

1590948

**Connector Part Information**

Harness Type: Chassis Wiring Harness  
 OEM Connector: 35554991  
 Service Connector: 88988373  
 Description: 56-Way F MX123 Series, Sealed( BK with BU Terminal Position Assurance)

**Terminal Part Information**

Terminal Type ID	Terminated Lead	Diagnostic Test Probe	Terminal Removal Tool
I	19351723	J-35616-64B (L-BU)	J-38125-213

**K19 Suspension Control Module (Z45)**

Pin	Size	Color	Circuit	Function	Terminal Type ID	Option
1	0.75	BU / GY	1114	Left Rear Shock Absorber Actuator Control	I	—
2	0.5	BN / WH	1207	Left Front Suspension Position Sensor Signal	I	—
3	—	—	—	Not Occupied	—	—
4	0.5	BK / BU	1206	Left Front Suspension Position Sensor Low Reference	I	—
5	0.5	GN / WH	1210	Left Rear Suspension Position Sensor Signal	I	—
6 - 10	—	—	—	Not Occupied	—	—
11	0.5	YE / WH	1213	Right Front Suspension Position Sensor Signal	I	—
12 - 13	—	—	—	Not Occupied	—	—
14	0.75	BN / GN	1118	Right Rear Shock Absorber Actuator Control	I	—
15	0.75	GN / VT	1115	Left Rear Shock Absorber Actuator Control	I	—
16	0.5	BU / RD	1205	Left Front Suspension Position Sensor Voltage Reference	I	—
17	0.75	BK / WH	1951	Signal Ground	I	—
18 - 19	—	—	—	Not Occupied	—	—
20	0.5	WH	4986	AUTOSAR CAN Bus [-] 1 Serial Data	I	—
21 - 22	—	—	—	Not Occupied	—	—
23	0.5	BU	4987	AUTOSAR CAN Bus [+] 1 Serial Data	I	—
24 - 25	—	—	—	Not Occupied	—	—
26	0.75	RD / GN	2440	Battery Positive Voltage	I	—
27	—	—	—	Not Occupied	—	—
28	0.75	GN / GY	1119	Right Rear Shock Absorber Actuator Control	I	—
29	0.75	BN / WH	1107	Left Front Shock Absorber Actuator Control	I	—

**K19 Suspension Control Module (Z45) (cont'd)**

Pin	Size	Color	Circuit	Function	Terminal Type ID	Option
30	0.75	GY / BU	1113	Left Front Shock Absorber Actuator Control	I	—
31	—	—	—	Not Occupied	—	—
32	0.5	BK / GN	1209	Left Rear Suspension Position Sensor Low Reference	I	—
33	0.5	YE / RD	1208	Left Rear Suspension Position Sensor Voltage Reference	I	—
34	0.5	WH	4986	AUTOSAR CAN Bus [-] 1 Serial Data	I	—
35	0.5	WH	4986	AUTOSAR CAN Bus [-] 1 Serial Data	I	—
36	0.5	BU	4987	AUTOSAR CAN Bus [+] 1 Serial Data	I	—
37	0.5	BU	4987	AUTOSAR CAN Bus [+] 1 Serial Data	I	—
38	0.5	BK / GY	1212	Right Front Suspension Position Sensor Low Reference	I	—
39	0.5	BN / RD	1211	Right Front Suspension Position Sensor Voltage Reference	I	—
40	—	—	—	Not Occupied	—	—
41	0.75	GY / WH	1117	Right Front Shock Absorber Actuator Control	I	—
42	0.75	BN / BU	1116	Right Front Shock Absorber Actuator Control	I	—
43 - 56	—	—	—	Not Occupied	—	—

**K20 Engine Control Module X1 (L3B)**

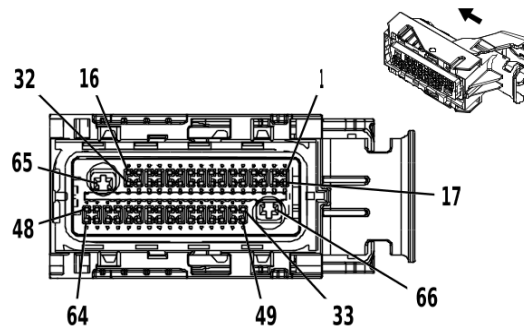

4504420

**Connector Part Information**

Harness Type: Engine Wiring Harness  
 OEM Connector: 34822-0033  
 Service Connector: 19371186  
 Description: 66-Way F 0.64, 2.8 Series, Sealed( BK with BU Terminal Position Assurance)

**Terminal Part Information**

Terminal Type ID	Terminated Lead	Diagnostic Test Probe	Terminal Removal Tool
I	13587518	J-35616-35 (VT)	J-38125-11A
II	19351723	J-35616-64B (L-BU)	J-38125-213

**K20 Engine Control Module X1 (L3B)**

Pin	Size	Color	Circuit	Function	Terminal Type ID	Option
1	0.5	YE	5991	Powertrain Relay Coil Control	II	—
2	0.5	YE / BK	625	Starter Enable Relay Control	II	—
3	0.5	YE / VT	4325	Starter Pinion Solenoid Actuator Relay Control	II	—
4 - 5	—	—	—	Not Occupied	—	—
6	0.5	VT / GY	3615	Intake Camshaft Profile Actuator 1 Control A	II	—
7	0.5	GN / BK	3616	Intake Camshaft Profile Actuator 1 Control B	II	—
8	0.5	GN	3585	Intake Camshaft Profile Actuator 2 Control A	II	—
9	0.5	BU	3584	Intake Camshaft Profile Actuator 2 Control B	II	—
10	0.5	YE / BU	3587	Intake Camshaft Profile Actuator 3 Control A	II	—
11	0.5	GY	3586	Intake Camshaft Profile Actuator 3 Control B	II	—
12	0.5	BU / WH	3589	Intake Camshaft Profile Actuator 1 Position Sensor Signal	II	—
13	0.5	GN / WH	3592	Intake Camshaft Profile Actuator 2 Position Sensor Signal	II	—
14	0.5	BK / GN	3593	Intake Camshaft Profile Actuator 3 Position Sensor Signal	II	—
15	0.5	WH / BU	6311	Cruise/ETC/TCC Brake Signal	II	—
16	0.75	VT / BU	5291	Powertrain Main Relay Fused Supply Voltage 2	II	—
17	0.5	GN / GY	465	Fuel Pump Primary Relay Control	II	—
18	0.5	WH / GY	459	Air Conditioning Compressor Clutch Relay Control	II	—
19 - 21	—	—	—	Not Occupied	—	—



**K20 Engine Control Module X1 (L3B) (cont'd)**

Pin	Size	Color	Circuit	Function	Terminal Type ID	Option
22	0.5	GN / YE	1402	Intake Camshaft Profile Actuator 4 Control A	II	—
23	0.5	GY / YE	1502	Intake Camshaft Profile Actuator 4 Control B	II	—
24	0.5	YE / VT	6265	Exhaust Camshaft Profile Actuator 2 Control B	II	—
25	0.5	VT / BK	6264	Exhaust Camshaft Profile Actuator 2 Control A	II	—
26	0.5	GY / BN	6262	Exhaust Camshaft Profile Actuator 3 Control B	II	—
27	0.5	GN / BN	6261	Exhaust Camshaft Profile Actuator 3 Control A	II	—
28	0.5	YE / BN	1702	Intake Camshaft Profile Actuator 4 Position Sensor Signal	II	—
29	0.5	GN / BK	6266	Exhaust Camshaft Profile Actuator 2 Position Sensor Signal	II	—
30	0.5	YE	6263	Exhaust Camshaft Profile Actuator 3 Position Sensor Signal	II	—
31	—	—	—	Not Occupied	—	—
32	0.5	VT / GN	439	Run/Crank Ignition 1 Voltage	II	—
33	0.5	BK / BU	1271	Accelerator Pedal Position Low Reference 1	II	—
34	0.5	YE / WH	3746	Camshaft Exhaust Lobe Axial Position Signal 1	II	—
35	0.5	BK / VT	1272	Accelerator Pedal Position Low Reference 2	II	—
36	0.5	YE / GN	3747	Camshaft Exhaust Lobe Axial Position Signal 2	II	—
37	—	—	—	Not Occupied	—	—
38	0.5	YE	4063	Hood Status A Signal	II	—
39	0.5	YE / WH	1161	Accelerator Pedal Position Signal 1	II	—
40 - 41	—	—	—	Not Occupied	—	—
42	0.5	GN / BN	2732	Engine Control Module LIN Bus 4	II	—
43 - 44	—	—	—	Not Occupied	—	—
45	0.5	BU / GY	4054	Private Serial Data Powertrain CAN Bus [-] Serial Data	II	—
46	0.5	WH	4055	Private Serial Data Powertrain CAN Bus [+] Serial Data	II	—
47	0.5	GN / WH	492	Mass Air Flow Sensor Signal	II	—
48	0.5	RD / BN	440	Battery Positive Voltage	II	—
49	0.5	WH / RD	1164	Accelerator Pedal Position 5V Reference 1	II	—
50	0.5	VT / WH	3744	Camshaft Intake Lobe Axial Position Signal 1	II	—
51	0.5	BN / RD	1274	Accelerator Pedal Position 5V Reference 2	II	—
52	0.5	VT / GN	3745	Camshaft Intake Lobe Axial Position Signal 2	II	—
53	0.5	BU / GY	636	Ambient Air Temperature Sensor Signal	II	—
54	—	—	—	Not Occupied	—	—
55	0.5	GN	380	Air Conditioning Refrigerant Pressure Sensor Signal	II	—
56	0.5	WH / GN	5380	Brake Position Sensor Signal	II	—
57	0.5	GN / WH	1162	Accelerator Pedal Position Signal 2	II	—
58	—	—	—	Not Occupied	—	—
59	0.5	WH	4978	AUTOSAR CAN Bus [-] 2 Serial Data	II	—
60	0.5	BU / YE	4979	AUTOSAR CAN Bus [+] 2 Serial Data	II	—
61 - 62	—	—	—	Not Occupied	—	—
63	0.5	WH	4976	AUTOSAR CAN Bus [-] 3 Serial Data	II	—
64	0.5	BU / BK	4977	AUTOSAR CAN Bus [+] 3 Serial Data	II	—
65	2	BK / WH	251	Signal Ground	I	—

**6-364 Electrical Component and Inline Harness Connector End Views****K20 Engine Control Module X1 (L3B) (cont'd)**

Pin	Size	Color	Circuit	Function	Terminal Type ID	Option
66	2	VT / BU	5290	Powertrain Main Relay Fused Supply Voltage 1	I	—

## K20 Engine Control Module X1 (L84 / L87)

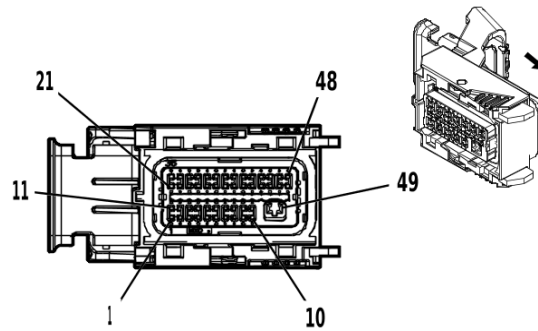

4596458

### Connector Part Information

Harness Type: Engine Wiring Harness

OEM Connector: 34576-0303

Service Connector: 19368142

Description: 49-Way F 0.64, 2.8 Series, Sealed( BK with BU Terminal Position Assurance)

### Terminal Part Information

Terminal Type ID	Terminated Lead	Diagnostic Test Probe	Terminal Removal Tool
I	13587518	J-35616-35 (VT)	J-38125-11A
II	19351723	J-35616-64B (L-BU)	J-38125-213

### K20 Engine Control Module X1 (L84 / L87)

Pin	Size	Color	Circuit	Function	Terminal Type ID	Option
1	0.5	GN / WH	492	Mass Air Flow Sensor Signal	II	—
2	—	—	—	Not Occupied	—	—
3	0.5	BU / GY	4054	Private Serial Data Powertrain CAN Bus [-] Serial Data	II	—
4	—	—	—	Not Occupied	—	—
5	0.5	WH	4976	AUTOSAR CAN Bus [-] 3 Serial Data	II	—
6	0.5	WH / BU	6311	Cruise/ETC/TCC Brake Signal	II	—
7	0.5	WH	4978	AUTOSAR CAN Bus [-] 2 Serial Data	II	—
8	—	—	—	Not Occupied	—	—
9	0.5	YE	5991	Powertrain Relay Coil Control	II	—
10	—	—	—	Not Occupied	—	—
11	0.5	YE	4063	Hood Status A Signal	II	—
12	0.5	BU / GY	636	Ambient Air Temperature Sensor Signal	II	—
13	0.5	WH	4055	Private Serial Data Powertrain CAN Bus [+] Serial Data	II	—
14	0.5	WH / GN	5380	Brake Position Sensor Signal	II	—
15	0.5	BU / BK	4977	AUTOSAR CAN Bus [+] 3 Serial Data	II	—
16	—	—	—	Not Occupied	—	—
17	0.5	BU / YE	4979	AUTOSAR CAN Bus [+] 2 Serial Data	II	—
18	0.5	WH / GY	459	Air Conditioning Compressor Clutch Relay Control	II	—
19 - 20	—	—	—	Not Occupied	—	—

**6-366 Electrical Component and Inline Harness Connector End Views**
**K20 Engine Control Module X1 (L84 / L87) (cont'd)**

Pin	Size	Color	Circuit	Function	Terminal Type ID	Option
21	0.5	GN / BU	428	EVAP Canister Purge Solenoid Control	II	—
22	0.5	WH / BN	1313	Variable Geometry Turbocharger Position Sensor Motor Open Control	II	—
23	0.5	BK / GN	580	Engine Control Sensors Low Reference 2	II	—
24	0.5	BK / BU	1271	Accelerator Pedal Position Low Reference 1	II	—
25 - 26	—	—	—	Not Occupied	—	—
27	0.5	GN / YE	3337	Transmission Internal Mode Switch Mode Control Y	II	—
28	0.5	BN / GN	1174	Oil Level Switch Signal	II	—
29	—	—	—	Not Occupied	—	—
30	0.5	BK / VT	1272	Accelerator Pedal Position Low Reference 2	II	—
31	—	—	—	Not Occupied	—	—
32	0.75	VT / BU	5291	Powertrain Main Relay Fused Supply Voltage 2	II	—
33	—	—	—	Not Occupied	—	—
34	0.5	RD / BN	440	Battery Positive Voltage	II	—
35	—	—	—	Not Occupied	—	—
36	0.5	YE / BK	625	Starter Enable Relay Control	II	—
37	0.5	GN / GY	465	Fuel Pump Primary Relay Control	II	—
38	0.5	WH / RD	1164	Accelerator Pedal Position 5V Reference 1	II	—
39	0.5	YE / WH	1161	Accelerator Pedal Position Signal 1	II	—
40	0.5	YE / BN	331	Oil Pressure Sensor Signal	II	—
41	0.5	GN	380	Air Conditioning Refrigerant Pressure Sensor Signal	II	—
42 - 43	—	—	—	Not Occupied	—	—
44	0.5	GN / WH	1162	Accelerator Pedal Position Signal 2	II	—
45	0.5	BN / RD	1274	Accelerator Pedal Position 5V Reference 2	II	—
46	—	—	—	Not Occupied	—	—
47	0.5	VT / GN	439	Run/Crank Ignition 1 Voltage	II	—
48	0.75	VT / BU	5291	Powertrain Main Relay Fused Supply Voltage 2	II	—
49	2	VT / BU	5290	Powertrain Main Relay Fused Supply Voltage 1	I	—

## K20 Engine Control Module X1 (LZ0)

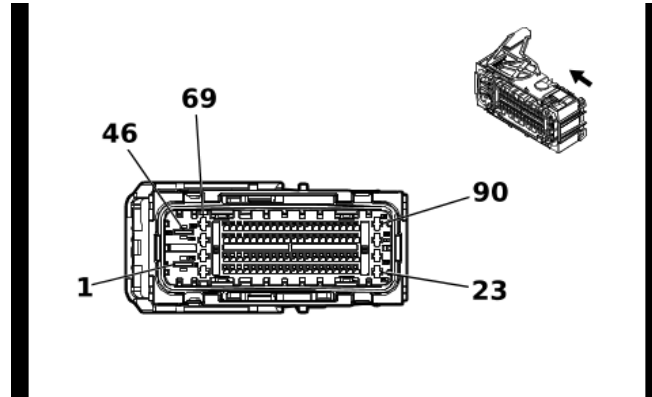

5492269

### Connector Part Information

Harness Type: Engine Wiring Harness

OEM Connector: 2344715-1

Service Connector: 84941451

Description: 90-Way F 0.64 GEN-Y, 2.8, 6.3 MCP Series, Sealed( BK with BU Terminal Position Assurance)

### Terminal Part Information

Terminal Type ID	Terminated Lead	Diagnostic Test Probe	Terminal Removal Tool
I	19367373	J-35616-64B (L-BU)	J-38125-215A
II	19371214	J-35616-4A (PU)	J-38125-215A
III	84616649	J-35616-42 (RD)	J-38125-556

### K20 Engine Control Module X1 (LZ0)

Pin	Size	Color	Circuit	Function	Terminal Type ID	Option
1	6	BN / BU	104	Glow Plug Control	III	—
2	2.5	GY / YE	1584	Glow Plug 4 Control	II	—
3 - 5	—	—	—	Not Occupied	—	—
6	0.5	WH / GY	459	Air Conditioning Compressor Clutch Relay Control	I	—
7	0.75	RD / BN	440	Battery Positive Voltage	I	—
8	0.5	GN / WH	492	Mass Air Flow Sensor Signal	I	—
9	—	—	—	Not Occupied	—	—
10	0.5	WH / BU	6311	Cruise/ETC/TCC Brake Signal	I	—
11	0.5	GY	2973	Coolant Flow Control Valve Position Signal	I	—
12	0.5	GN / GY	7316	Intake Manifold Runner Valve Actuator Control	I	—
13	0.5	GN	10289	Exhaust Gas Temperature Sensor SENT 1 Signal	I	—
14	0.5	BU	10290	Exhaust Gas Temperature Sensor SENT 2 Signal	I	—
15	0.5	BN / GN	4305	Exhaust Flow Control Valve 1	I	—
16	0.5	WH	4055	Private Serial Data Powertrain CAN Bus [+] Serial Data	I	—
17	0.5	BU / BK	4977	AUTOSAR CAN Bus [+] 3 Serial Data	I	—
18	0.5	BU / YE	4979	AUTOSAR CAN Bus [+] 2 Serial Data	I	—
19	0.5	BK / GN	580	Engine Control Sensors Low Reference 2	I	—

**6-368 Electrical Component and Inline Harness Connector End Views**
**K20 Engine Control Module X1 (LZ0) (cont'd)**

Pin	Size	Color	Circuit	Function	Terminal Type ID	Option
20	—	—	—	Not Occupied	—	—
21	0.75	GY / BK	1330	Variable Geometry Turbocharger Position Sensor Motor Close Control	I	—
22	0.75	WH / BN	1313	Variable Geometry Turbocharger Position Sensor Motor Open Control	I	—
23	2.5	GY / GN	1583	Glow Plug 3 Control	II	—
24	2.5	GY / BN	1582	Glow Plug 2 Control	II	—
25	0.75	VT / GN	439	Run/Crank Ignition 1 Voltage	I	—
26	0.5	YE	5991	Powertrain Relay Coil Control	I	—
27	—	—	—	Not Occupied	—	—
28	0.5	GN / BN	507	Wait To Start Indicator Control	I	—
29	—	—	—	Not Occupied	—	—
30	0.5	BK / GY	626	Engine Control Vehicle Sensors Low Reference 1	I	—
31 - 32	—	—	—	Not Occupied	—	—
33	0.5	WH / BN	2363	Exhaust Pressure Sensor SENT 1 Signal	I	—
34	0.5	VT / YE	5947	Turbocharger Vane Position Sensor Signal	I	—
35	0.5	BN / WH	5763	Exhaust Gas Recirculation Position Signal	I	—
36	0.5	BU / GY	2978	Coolant Diverter Valve Position Signal	I	—
37	0.5	GN	10478	Low Pressure Exhaust Gas Recirculation Sensor SENT Signal	I	—
38	0.5	BU / GY	4054	Private Serial Data Powertrain CAN Bus [-] Serial Data	I	—
39	0.5	WH	4976	AUTOSAR CAN Bus [-] 3 Serial Data	I	—
40	0.5	WH	4978	AUTOSAR CAN Bus [-] 2 Serial Data	I	—
41	—	—	—	Not Occupied	—	—
42	0.5	YE / BK	625	Starter Enable Relay Control	I	—
43	0.75	VT / BK	5746	Exhaust Gas Recirculation Valve Low Control	I	—
44	0.75	WH / VT	5764	Exhaust Gas Recirculation Valve High Control	I	—
45	2.5	GY / WH	1585	Glow Plug 5 Control	II	—
46	4	BK / WH	251	Signal Ground	III	—
47	2.5	GY / VT	1586	Glow Plug 6 Control	II	—
48	0.5	WH / RD	480	Engine Control Vehicle Sensors 5 Volt Reference 1	I	—
49	0.5	GN / WH	1162	Accelerator Pedal Position Signal 2	I	—
50	0.5	BK / VT	1272	Accelerator Pedal Position Low Reference 2	I	—
51	0.5	BK / BU	1271	Accelerator Pedal Position Low Reference 1	I	—
52	0.5	WH / GN	5380	Brake Position Sensor Signal	I	—
53 - 54	—	—	—	Not Occupied	—	—
55	0.5	YE	4063	Hood Status A Signal	I	—
56 - 58	—	—	—	Not Occupied	—	—
59	0.5	GN	380	Air Conditioning Refrigerant Pressure Sensor Signal	I	—
60	0.5	YE / BN	331	Oil Pressure Sensor Signal	I	—
61	0.5	YE / GY	3926	Crankcase Differential Pressure Sensor Signal	I	—
62 - 63	—	—	—	Not Occupied	—	—
64	0.5	GN / BU	3889	Powertrain Sensor Bus Relay Control	I	—

**K20 Engine Control Module X1 (LZ0) (cont'd)**

Pin	Size	Color	Circuit	Function	Terminal Type ID	Option
65	—	—	—	Not Occupied	—	—
66	0.75	BN	1421	Exhaust Restrictor Motor Closed Control	I	—
67	0.75	YE / BN	1420	Exhaust Restrictor Motor Open Control	I	—
68	2.5	GY / BU	1581	Glow Plug 1 Control	II	—
69	2.5	VT / BU	5291	Powertrain Main Relay Fused Supply Voltage 2	II	—
70	0.5	BU / RD	460	Engine Control Sensors 5 Volt Reference 1	I	—
71	0.5	BN / RD	1274	Accelerator Pedal Position 5V Reference 2	I	—
72	0.5	WH / RD	1164	Accelerator Pedal Position 5V Reference 1	I	—
73	0.5	YE / WH	1161	Accelerator Pedal Position Signal 1	I	—
74	0.5	BU / GY	636	Ambient Air Temperature Sensor Signal	I	—
75	0.5	VT	7485	Engine Oil Temperature Sensor 2 Signal	I	—
76 - 85	—	—	—	Not Occupied	—	—
86	0.5	GN / GY	465	Fuel Pump Primary Relay Control	I	—
87	0.75	VT / BU	5294	Powertrain Main Relay Fused Supply Voltage 5	I	—
88	0.75	GY / BN	2972	Coolant Flow Control Actuator Control Close	I	—
89	0.75	GY / BU	2971	Coolant Flow Control Actuator Control Open	I	—
90	2.5	VT / BU	5290	Powertrain Main Relay Fused Supply Voltage 1	II	—

**K20 Engine Control Module X2 (L3B)**

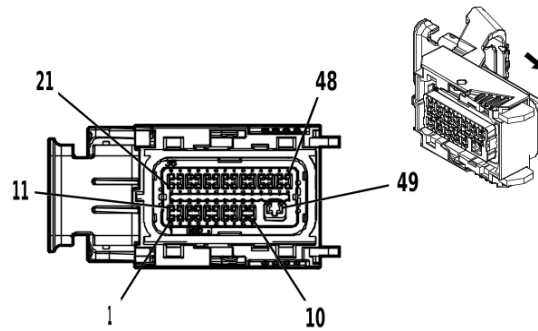

4596458

**Connector Part Information**

Harness Type: Engine Wiring Harness  
 OEM Connector: 34576-0103  
 Service Connector: 19355678  
 Description: 49-Way F 0.64, 2.8 Series, Sealed( BK with BK Terminal Position Assurance)

**Terminal Part Information**

Terminal Type ID	Terminated Lead	Diagnostic Test Probe	Terminal Removal Tool
I	13587518	J-35616-35 (VT)	J-38125-11A
II	19351723	J-35616-64B (L-BU)	J-38125-213

**K20 Engine Control Module X2 (L3B)**

Pin	Size	Color	Circuit	Function	Terminal Type ID	Option
1	0.5	VT / GN	4320	Powertrain Sensor Bus Enable	II	—
2	0.5	BU / RD	460	Engine Control Sensors 5 Volt Reference 1	II	—
3 - 4	—	—	—	Not Occupied	—	—
5	0.5	BN / BU	2447	Evaporative Purge Pump Pressure Signal	II	—
6 - 8	—	—	—	Not Occupied	—	—
9	0.75	VT / BU	5294	Powertrain Main Relay Fused Supply Voltage 5	II	—
10	0.5	BU / GY	2978	Coolant Diverter Valve Position Signal	II	—
11	—	—	—	Not Occupied	—	—
12	0.5	BK / GN	580	Engine Control Sensors Low Reference 2	II	—
13 - 14	—	—	—	Not Occupied	—	—
15	0.5	GN / YE	3337	Transmission Internal Mode Switch Mode Control Y	II	—
16	0.5	YE / BN	331	Oil Pressure Sensor Signal	II	—
17 - 18	—	—	—	Not Occupied	—	—
19	0.5	BU / WH	10786	Fuel Rail Pressure Sensor SENT 1 Signal	II	—
20	0.5	WH	2590	Turbocharger Wastegate Motor Feedback Signal	II	—
21	—	—	—	Not Occupied	—	—
22	0.5	BK / GY	626	Engine Control Vehicle Sensors Low Reference 1	II	—
23	0.5	VT	7485	Engine Oil Temperature Sensor 2 Signal	II	—
24	0.5	BN / BU	357	Oil Temperature Sensor Signal	II	—
25	0.5	YE / WH	3200	Throttle Inlet Absolute Pressure Sensor Signal	II	—



**K20 Engine Control Module X2 (L3B) (cont'd)**

Pin	Size	Color	Circuit	Function	Terminal Type ID	Option
26 - 28	—	—	—	Not Occupied	—	—
29	0.5	BU / GY	2125	Ignition Control 5	II	—
30	—	—	—	Not Occupied	—	—
31	0.5	YE / GY	6936	HO2S Signal	II	—
32	0.5	BN	6934	HO2S Ground	II	—
33	0.5	GN / YE	4623	Engine Control Module LIN Bus 3	II	—
34	0.5	GY / WH	3113	HO2S Heater Low Control Bank 1 Sensor 1	II	—
35	—	—	—	Not Occupied	—	—
36	0.5	WH / RD	480	Engine Control Vehicle Sensors 5 Volt Reference 1	II	—
37	0.5	YE / BK	3000	Coolant Temperature Sensor 2 Signal	II	—
38 - 39	—	—	—	Not Occupied	—	—
40	0.5	GY / VT	2404	Engine Block Coolant Temperature Signal	II	—
41 - 44	—	—	—	Not Occupied	—	—
45	0.5	GN	6935	HO2S Pump Current Trim Signal	II	—
46	0.5	BN / WH	6933	HO2S Pump Current Signal	II	—
47	0.5	GN / VT	4621	Engine Control Module LIN Bus 1	II	—
48	0.5	GN / YE	4622	Engine Control Module LIN Bus 2	II	—
49	2	BK / WH	251	Signal Ground	I	—

**K20 Engine Control Module X2 (L84 / L87)**

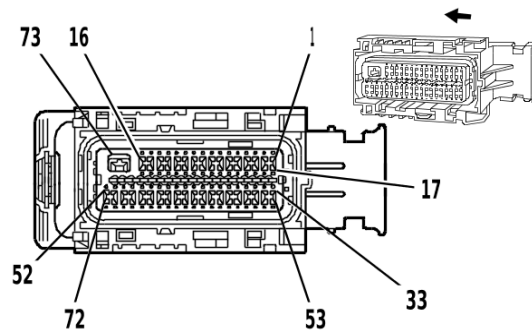

1673472

**Connector Part Information**

Harness Type: Engine Wiring Harness  
 OEM Connector: 34566-0103  
 Service Connector: 19333090  
 Description: 73-Way F 0.64, 2.8 Series, Sealed( BK with BK Terminal Position Assurance)

**Terminal Part Information**

Terminal Type ID	Terminated Lead	Diagnostic Test Probe	Terminal Removal Tool
I	13587518	J-35616-35 (VT)	J-38125-11A
II	19354746	J-35616-64B (L-BU)	J-38125-215A

**K20 Engine Control Module X2 (L84 / L87)**

Pin	Size	Color	Circuit	Function	Terminal Type ID	Option
1	0.5	GN / YE	3212	HO2S Heater Low Control Bank 2 Sensor 1	II	—
2	0.5	GY	5493	Cylinder Deactivation Solenoid Valve Control 3	II	—
3	0.5	BK / YE	548	Engine Control Sensors Low Reference 1	II	—
4 - 6	—	—	—	Not Occupied	—	—
7	0.5	GN / YE	4622	Engine Control Module LIN Bus 2	II	—
8	0.5	GN / VT	4621	Engine Control Module LIN Bus 1	II	—
9	0.5	VT / BU	5294	Powertrain Main Relay Fused Supply Voltage 5	II	—
10	0.5	VT / GY	3110	HO2S High Signal Bank 1 Sensor 1	II	—
11	0.5	WH / BK	3111	HO2S Low Signal Bank 1 Sensor 1	II	—
12	0.5	YE / BU	2124	Ignition Control 4	II	—
13	0.5	BN / BU	2126	Ignition Control 6	II	—
14	0.5	VT / BU	5294	Powertrain Main Relay Fused Supply Voltage 5	II	—
15	0.5	VT / BU	5294	Powertrain Main Relay Fused Supply Voltage 5	II	—
16	0.5	VT / BU	5294	Powertrain Main Relay Fused Supply Voltage 5	II	—
17	0.5	GY / WH	3113	HO2S Heater Low Control Bank 1 Sensor 1	II	—
18	0.5	YE / GY	2493	Cylinder Shutoff Solenoid Enable Signal 3	II	—
19 - 21	—	—	—	Not Occupied	—	—
22	0.5	BK / GY	626	Engine Control Vehicle Sensors Low Reference 1	II	—
23	0.5	BN / WH	3100	Diesel Exhaust Fluid Dosing Valve Low Control	II	—
24	0.5	BK / YE	2834	Fuel Rail Pressure Solenoid Valve Low Control	II	—

**K20 Engine Control Module X2 (L84 / L87) (cont'd)**

Pin	Size	Color	Circuit	Function	Terminal Type ID	Option
25	0.5	BU	179	Engine Oil Pump Control	II	—
26	0.5	VT / WH	3210	HO2S High Signal Bank 2 Sensor 1	II	—
27	0.5	YE / WH	3211	HO2S Low Signal Bank 2 Sensor 1	II	—
28	0.5	GN / BU	2123	Ignition Control 3	II	—
29	0.5	BU / GY	2125	Ignition Control 5	II	—
30	0.5	BK / GY	2130	Ignition Control Low Reference Bank 2	II	—
31	0.5	BN	5496	Cylinder Deactivation Solenoid Valve Control 6	II	—
32	0.5	YE / BN	2496	Cylinder Shutoff Solenoid Enable Signal 6	II	—
33	0.5	WH / BN	3223	HO2S Heater Low Control Bank 2 Sensor 2	II	—
34	—	—	—	Not Occupied	—	—
35	0.5	BU	179	Engine Oil Pump Control	II	—
36	0.5	YE / GN	2494	Cylinder Shutoff Solenoid Enable Signal 4	II	—
37	0.5	VT / BU	5294	Powertrain Main Relay Fused Supply Voltage 5	II	—
38	—	—	—	Not Occupied	—	—
39	0.5	WH / RD	480	Engine Control Vehicle Sensors 5 Volt Reference 1	II	—
40 - 45	—	—	—	Not Occupied	—	—
46	0.5	YE / BU	3221	HO2S Low Signal Bank 2 Sensor 2	II	—
47	0.5	VT / GN	3220	HO2S High Signal Bank 2 Sensor 2	II	—
48	0.5	GN / YE	4622	Engine Control Module LIN Bus 2	II	—
49	0.5	BK / WH	251	Signal Ground	II	—
50	0.75	BK / GY	2303	Knock Sensor Low Reference 2	II	—
51	0.75	BK / YE	1716	Knock Sensor Low Reference 1	II	—
52	0.5	BN / WH	582	Throttle Actuator Close Control	II	—
53	0.5	GY / WH	3122	HO2S Heater Low Control Bank 1 Sensor 2	II	—
54	0.5	VT	5495	Cylinder Deactivation Solenoid Valve Control 5	II	—
55	0.5	WH / VT	2495	Cylinder Shutoff Solenoid Enable Signal 5	II	—
56	0.5	YE / BU	5494	Cylinder Deactivation Solenoid Valve Control 4	II	—
57	0.5	GN	5492	Cylinder Deactivation Solenoid Valve Control 2	II	—
58	0.5	WH / GN	2492	Cylinder Shutoff Solenoid Enable Signal 2	II	—
59	0.5	BU / RD	460	Engine Control Sensors 5 Volt Reference 1	II	—
60 - 65	—	—	—	Not Occupied	—	—
66	0.5	WH / YE	3121	HO2S Low Signal Bank 1 Sensor 2	II	—
67	0.5	VT / BU	3120	HO2S High Signal Bank 1 Sensor 2	II	—
68	—	—	—	Not Occupied	—	—
69	0.5	BN / BU	357	Oil Temperature Sensor Signal	II	—
70	0.75	WH / GY	1876	Knock Sensor 2 Signal	II	—
71	0.75	VT / GY	496	Knock Sensor 1 Signal	II	—
72	0.5	YE	581	Throttle Actuator Open Control	II	—
73	2.5	BK / WH	251	Signal Ground	I	—

**K20 Engine Control Module X2 (LZ0)**

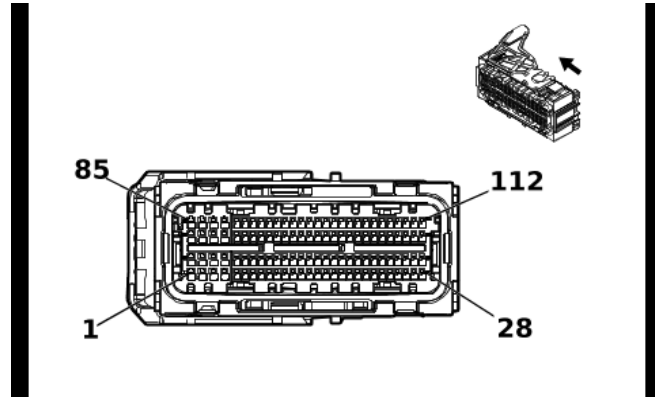

5491584

**Connector Part Information**

Harness Type: Engine Wiring Harness

OEM Connector: 2344717-2

Service Connector: 84941452

Description: 112-Way F 0.64 GEN-Y, 1.2 MCON Series, Sealed( BK with BK Terminal Position Assurance)

**Terminal Part Information**

Terminal Type ID	Terminated Lead	Diagnostic Test Probe	Terminal Removal Tool
I	19367373	J-35616-64B (L-BU)	J-38125-215A
II	84963773	J-35616-12 (BU)	J-38125-215A

**K20 Engine Control Module X2 (LZ0)**

Pin	Size	Color	Circuit	Function	Terminal Type ID	Option
1	1.5	GN	4803	Direct Fuel Injector High Voltage Control Cylinder 3	II	—
2	1.5	GY / BU	4804	Direct Fuel Injector High Voltage Control Cylinder 4	II	—
3	0.75	YE / VT	2420	Fuel High Pressure Pump Low Enable Signal	II	—
4	0.75	YE / VT	7245	High Pressure Fuel Pump Low Enable Signal	II	—
5	0.5	GY / YE	5297	Exhaust Camshaft Position Sensor 1 Voltage Reference	I	—
6	0.5	GN	6271	Crankshaft Position Sensor Signal	I	—
7	0.5	VT / BU	6270	Crankshaft Position Sensor Voltage	I	—
8	—	—	—	Not Occupied	—	—
9	0.5	BN	25	Charge Indicator Control	I	—
10	0.75	BU / YE	11616	Diesel Exhaust Fluid Dosing Valve Low Control 2	I	—
11	0.5	BK / GN	3235	Exhaust Gas Recirculation Temperature Sensor 3 Low Reference	I	—
12	0.5	YE / BU	3680	Charge Air Cooler Outlet Temperature Sensor Low Reference	I	—
13	0.5	YE / BK	3682	Charge Air Cooler Inlet Temperature Sensor Low Reference	I	—
14 - 22	—	—	—	Not Occupied	—	—
23	0.75	BN / WH	3100	Diesel Exhaust Fluid Dosing Valve Low Control	I	—
24	0.5	BK / YE	2834	Fuel Rail Pressure Solenoid Valve Low Control	I	—

**K20 Engine Control Module X2 (LZ0) (cont'd)**

Pin	Size	Color	Circuit	Function	Terminal Type ID	Option
25	0.5	BU	179	Engine Oil Pump Control	I	—
26	—	—	—	Not Occupied	—	—
27	0.75	BN / WH	582	Throttle Actuator Close Control	I	—
28	0.75	YE	581	Throttle Actuator Open Control	I	—
29	1.5	GN / GY	4903	Direct Fuel Injector High Voltage Supply Cylinder 3	II	—
30	1.5	BU / WH	4904	Direct Fuel Injector High Voltage Supply Cylinder 4	II	—
31	0.75	GY / BN	2419	Fuel High Pressure Pump High Side Supply Voltage	II	—
32	0.75	GY / BN	7244	High Pressure Fuel Pump High Side Control	II	—
33	0.5	BK / GY	5296	Exhaust Camshaft Position Sensor Low Reference 1	I	—
34	0.5	VT / BK	5273	Exhaust Camshaft Position Sensor 1	I	—
35	0.5	BK / VT	6272	Crankshaft Position Sensor Low Reference	I	—
36	—	—	—	Not Occupied	—	—
37	0.5	BU	3017	Fuel Heater Relay 1 Control	I	—
38	—	—	—	Not Occupied	—	—
39	0.5	WH / GY	3234	Exhaust Gas Recirculation Temperature Sensor 3 Signal	I	—
40	0.5	BN	3681	Charge Air Cooler Outlet Temperature Sensor Signal	I	—
41	0.5	GN	3683	Charge Air Cooler Inlet Temperature Sensor Signal	I	—
42 - 48	—	—	—	Not Occupied	—	—
49	0.75	BU	11615	Diesel Exhaust Fluid Dosing Valve High Control 2	I	—
50	—	—	—	Not Occupied	—	—
51	0.75	BN	3099	Diesel Exhaust Fluid Dosing Valve High Control	I	—
52	0.5	BU / WH	2530	Fuel Rail Pressure Solenoid Valve Control	I	—
53	0.5	YE / BN	106	Oil Pump Motor Control	I	—
54	—	—	—	Not Occupied	—	—
55	0.75	BK / BU	1408	Variable Swirl Valve Close Control	I	—
56	0.75	BK / GN	1389	Variable Swirl Valve Open Control	I	—
57	1.5	VT / GY	4906	Direct Fuel Injector High Voltage Supply Cylinder 6	II	—
58	1.5	BN / WH	4901	Direct Fuel Injector High Voltage Supply Cylinder 1	II	—
59	1.5	GN / WH	4905	Direct Fuel Injector High Voltage Supply Cylinder 5	II	—
60	1.5	BU / GY	4902	Direct Fuel Injector High Voltage Supply Cylinder 2	II	—
61	—	—	—	Not Occupied	—	—
62	0.5	GN / YE	3337	Transmission Internal Mode Switch Mode Control Y	I	—
63 - 65	—	—	—	Not Occupied	—	—
66	0.5	BN / RD	2917	Fuel Rail Pressure Sensor 5V Reference	I	—
67	0.5	BK / GN	2919	Fuel Rail Pressure Sensor Low Reference	I	—
68	—	—	—	Not Occupied	—	—

**6-376 Electrical Component and Inline Harness Connector End Views**
**K20 Engine Control Module X2 (LZ0) (cont'd)**

Pin	Size	Color	Circuit	Function	Terminal Type ID	Option
69	0.5	BN / BU	357	Oil Temperature Sensor Signal	I	—
70	0.5	YE / BK	3000	Coolant Temperature Sensor 2 Signal	I	—
71 - 72	—	—	—	Not Occupied	—	—
73	0.5	WH / BU	7329	Pre-Throttle Air Temperature Signal	I	—
74	—	—	—	Not Occupied	—	—
75	0.5	BK / YE	548	Engine Control Sensors Low Reference 1	I	—
76	0.5	GN / VT	4621	Engine Control Module LIN Bus 1	I	—
77	0.5	GN / YE	4622	Engine Control Module LIN Bus 2	I	—
78	0.5	GN / YE	4623	Engine Control Module LIN Bus 3	I	—
79 - 82	—	—	—	Not Occupied	—	—
83	0.75	BU / BN	2977	Coolant Diverter Valve Actuator Control Close	I	—
84	0.75	BU	2976	Coolant Diverter Valve Actuator Control Open	I	—
85	1.5	VT / GN	4806	Direct Fuel Injector High Voltage Control Cylinder 6	II	—
86	1.5	BN	4801	Direct Fuel Injector High Voltage Control Cylinder 1	II	—
87	1.5	BU	4802	Direct Fuel Injector High Voltage Control Cylinder 2	II	—
88	1.5	WH / GN	4805	Direct Fuel Injector High Voltage Control Cylinder 5	II	—
89	—	—	—	Not Occupied	—	—
90	0.5	BU / WH	3630	Throttle Position Sensor SENT 1 Signal	I	—
91	0.5	BU / GN	4012	Exhaust Gas Recirculation 2 Valve Position Sensor Signal	I	—
92	0.5	GY	23	Generator Field Duty Cycle Signal	I	—
93	—	—	—	Not Occupied	—	—
94	0.5	BU / WH	2918	Fuel Rail Pressure Sensor Signal	I	—
95	0.5	YE / BU	2408	Engine Inlet Coolant Temperature Signal	I	—
96	0.5	BN / YE	2161	Fuel Rail Pressure Sensor 2 Signal	I	—
97	0.5	VT	2988	Engine Outlet Coolant Temperature Signal	I	—
98 - 100	—	—	—	Not Occupied	—	—
101	0.5	GN / WH	432	Manifold Absolute Pressure Sensor Signal	I	—
102	0.5	GN / YE	37	Engine Block Temperature Sensor Signal	I	—
103	0.5	BU / BK	1422	Engine Water Charge Air Coolant Temperature Signal	I	—
104 - 110	—	—	—	Not Occupied	—	—
111	0.75	BU / BN	4013	Exhaust Gas Recirculation 2 Valve Close Control	I	—
112	0.75	BU / WH	4014	Exhaust Gas Recirculation 2 Valve Open Control	I	—

### K20 Engine Control Module X3 (L3B)

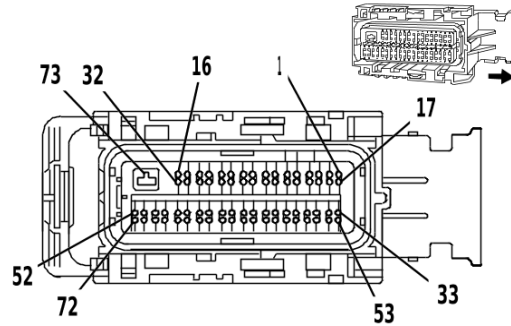

1590596

#### Connector Part Information

Harness Type: Engine Wiring Harness  
 OEM Connector: 35406518  
 Service Connector: 19333091  
 Description: 73-Way F 0.64, 2.8 Series, Sealed( BK with GY Terminal Position Assurance)

#### Terminal Part Information

Terminal Type ID	Terminated Lead	Diagnostic Test Probe	Terminal Removal Tool
I	13587518	J-35616-35 (VT)	J-38125-11A
II	19354746	J-35616-64B (L-BU)	J-38125-215A

#### K20 Engine Control Module X3 (L3B)

Pin	Size	Color	Circuit	Function	Terminal Type ID	Option
1	—	—	—	Not Occupied	—	—
2	0.5	GN	3060	Turbocharger Bypass Solenoid Valve Control Bank 1	II	—
3	0.5	BN	25	Charge Indicator Control	II	—
4 - 5	—	—	—	Not Occupied	—	—
6	0.5	VT / BU	6270	Crankshaft Position Sensor Voltage	II	—
7	0.5	BN / RD	2701	Throttle Position Sensor 5V Reference	II	—
8	—	—	—	Not Occupied	—	—
9	0.5	GN / WH	432	Manifold Absolute Pressure Sensor Signal	II	—
10	0.5	VT / BU	3120	HO2S High Signal Bank 1 Sensor 2	II	—
11	0.5	WH / YE	3121	HO2S Low Signal Bank 1 Sensor 2	II	—
12	0.5	VT / BN	5284	Intake Camshaft Position Actuator Solenoid Valve 1	II	—
13	0.5	GY / BU	5282	Exhaust Camshaft Position Actuator Solenoid Valve 1	II	—
14	0.75	BU	2976	Coolant Diverter Valve Actuator Control Open	II	—
15	0.75	WH / BN	2591	Turbocharger Wastegate Motor Open Control	II	—
16	0.75	WH / BU	2592	Turbocharger Wastegate Motor Close Control	II	—
17 - 20	—	—	—	Not Occupied	—	—
21	0.5	BK / YE	548	Engine Control Sensors Low Reference 1	II	—
22	0.5	BK / VT	6272	Crankshaft Position Sensor Low Reference	II	—
23	0.5	BK / BN	2752	Throttle Position Sensor Low Reference	II	—

**6-378 Electrical Component and Inline Harness Connector End Views**
**K20 Engine Control Module X3 (L3B) (cont'd)**

Pin	Size	Color	Circuit	Function	Terminal Type ID	Option
24	0.5	YE / BU	2408	Engine Inlet Coolant Temperature Signal	II	—
25	0.5	VT	2988	Engine Outlet Coolant Temperature Signal	II	—
26	0.5	WH / BU	7329	Pre-Throttle Air Temperature Signal	II	—
27	0.5	BU / YE	8938	Engine Integrated Exhaust Manifold Temperature Signal	II	—
28	0.5	BK / BN	6753	Camshaft Position Actuator Solenoid Valve W Low Reference	II	—
29	0.5	BK / VT	6754	Camshaft Position Actuator Solenoid Valve X Low Reference	II	—
30	0.5	YE	581	Throttle Actuator Open Control	II	—
31	0.5	BN / WH	582	Throttle Actuator Close Control	II	—
32	0.75	BU / BN	2977	Coolant Diverter Valve Actuator Control Close	II	—
33	0.5	VT / GY	496	Knock Sensor 1 Signal	II	—
34	0.5	WH / GY	1876	Knock Sensor 2 Signal	II	—
35	0.5	BK / GN	469	Manifold Absolute Pressure Sensor Low Reference	II	—
36	0.5	GN / BU	428	EVAP Canister Purge Solenoid Control	II	—
37 - 38	—	—	—	Not Occupied	—	—
39	0.5	BK / GN	5301	Intake Camshaft Position Sensor Low Reference 1	II	—
40	0.5	BK / GY	5296	Exhaust Camshaft Position Sensor Low Reference 1	II	—
41	—	—	—	Not Occupied	—	—
42	0.5	VT / BK	5273	Exhaust Camshaft Position Sensor 1	II	—
43	0.5	GN	6271	Crankshaft Position Sensor Signal	II	—
44	0.75	YE / BU	2124	Ignition Control 4	II	—
45	0.75	BU / WH	2122	Ignition Control 2	II	—
46	0.75	BK / BU	2129	Ignition Control Low Reference Bank 1	II	—
47	0.5	GY / WH	3122	HO2S Heater Low Control Bank 1 Sensor 2	II	—
48	0.5	BU / WH	3630	Throttle Position Sensor SENT 1 Signal	II	—
49	0.75	BU / WH	4904	Direct Fuel Injector High Voltage Supply Cylinder 4	II	—
50	0.75	GY / BU	4804	Direct Fuel Injector High Voltage Control Cylinder 4	II	—
51	0.75	BU / GY	4902	Direct Fuel Injector High Voltage Supply Cylinder 2	II	—
52	0.75	BU	4802	Direct Fuel Injector High Voltage Control Cylinder 2	II	—
53	0.5	BK / YE	1716	Knock Sensor Low Reference 1	II	—
54	0.5	BK / GY	2303	Knock Sensor Low Reference 2	II	—
55	0.5	GY / RD	2704	Manifold Absolute Pressure Sensor 5V Reference	II	—
56	0.5	YE / BN	106	Oil Pump Motor Control	II	—
57	0.5	BU	179	Engine Oil Pump Control	II	—
58	—	—	—	Not Occupied	—	—
59	0.5	GY / BU	5300	Intake Camshaft Position Sensor 1 Voltage Reference	II	—
60	0.5	GY / YE	5297	Exhaust Camshaft Position Sensor 1 Voltage Reference	II	—



**K20 Engine Control Module X3 (L3B) (cont'd)**

<b>Pin</b>	<b>Size</b>	<b>Color</b>	<b>Circuit</b>	<b>Function</b>	<b>Terminal Type ID</b>	<b>Option</b>
61	0.5	GY	23	Generator Field Duty Cycle Signal	II	—
62	—	—	—	Not Occupied	—	—
63	0.5	YE / VT	5275	Intake Camshaft Position Sensor 1	II	—
64	0.75	BU / VT	2121	Ignition Control 1	II	—
65	0.75	GN / BU	2123	Ignition Control 3	II	—
66	—	—	—	Not Occupied	—	—
67	0.5	VT / BK	7300	High Pressure Fuel Pump Low Control	II	—
68	0.5	YE	7301	High Pressure Fuel Pump High Control	II	—
69	0.75	BN / WH	4901	Direct Fuel Injector High Voltage Supply Cylinder 1	II	—
70	0.75	BN	4801	Direct Fuel Injector High Voltage Control Cylinder 1	II	—
71	0.75	GN / GY	4903	Direct Fuel Injector High Voltage Supply Cylinder 3	II	—
72	0.75	GN	4803	Direct Fuel Injector High Voltage Control Cylinder 3	II	—
73	2	VT / BU	5290	Powertrain Main Relay Fused Supply Voltage 1	I	—

**K20 Engine Control Module X3 (L84 / L87)**

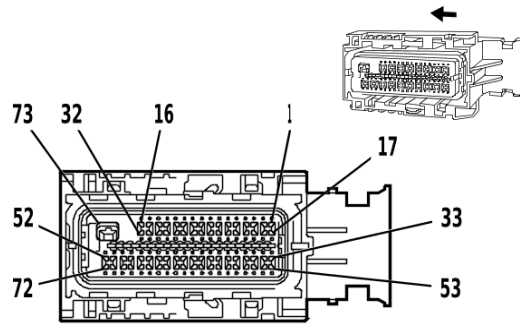

1650395

**Connector Part Information**

Harness Type: Engine Wiring Harness  
 OEM Connector: 34566-8753  
 Service Connector: 19333091  
 Description: 73-Way F 0.64, 2.8 Series, Sealed( BK with GY Terminal Position Assurance)

**Terminal Part Information**

Terminal Type ID	Terminated Lead	Diagnostic Test Probe	Terminal Removal Tool
I	13587518	J-35616-35 (VT)	J-38125-11A
II	19354746	J-35616-64B (L-BU)	J-38125-215A

**K20 Engine Control Module X3 (L84 / L87)**

Pin	Size	Color	Circuit	Function	Terminal Type ID	Option
1	0.5	WH	5497	Cylinder Deactivation Solenoid Valve Control 7	II	—
2	0.5	GN / GY	2497	Cylinder Shutoff Solenoid Enable Signal 7	II	—
3 - 4	—	—	—	Not Occupied	—	—
5	0.5	VT / BN	5284	Intake Camshaft Position Actuator Solenoid Valve 1	II	—
6	0.5	VT / GN	4320	Powertrain Sensor Bus Enable	II	—
7	—	—	—	Not Occupied	—	—
8	0.5	YE / VT	5275	Intake Camshaft Position Sensor 1	II	—
9	0.5	GY / BU	5300	Intake Camshaft Position Sensor 1 Voltage Reference	II	—
10	0.5	GN	6271	Crankshaft Position Sensor Signal	II	—
11	—	—	—	Not Occupied	—	—
12	0.5	BU / WH	2122	Ignition Control 2	II	—
13	0.5	VT / WH	2128	Ignition Control 8	II	—
14	0.5	BN	25	Charge Indicator Control	II	—
15	—	—	—	Not Occupied	—	—
16	0.75	YE	7301	High Pressure Fuel Pump High Control	II	—
17 - 20	—	—	—	Not Occupied	—	—
21	0.5	BK / BN	6753	Camshaft Position Actuator Solenoid Valve W Low Reference	II	—
22 - 23	—	—	—	Not Occupied	—	—

**K20 Engine Control Module X3 (L84 / L87) (cont'd)**

Pin	Size	Color	Circuit	Function	Terminal Type ID	Option
24	0.5	BK / GN	5301	Intake Camshaft Position Sensor Low Reference 1	II	—
25	0.5	VT / BU	6270	Crankshaft Position Sensor Voltage	II	—
26	0.5	BK / VT	6272	Crankshaft Position Sensor Low Reference	II	—
27	—	—	—	Not Occupied	—	—
28	0.5	GN / GY	2127	Ignition Control 7	II	—
29	0.5	BU / VT	2121	Ignition Control 1	II	—
30	0.5	BK / BU	2129	Ignition Control Low Reference Bank 1	II	—
31	—	—	—	Not Occupied	—	—
32	0.75	VT / BK	7300	High Pressure Fuel Pump Low Control	II	—
33	0.5	YE / VT	4325	Starter Pinion Solenoid Actuator Relay Control	II	—
34	0.5	WH / BU	2491	Cylinder Shutoff Solenoid Enable Signal 1	II	—
35	0.5	WH / YE	2498	Cylinder Shutoff Solenoid Enable Signal 8	II	—
36	0.5	BK / BN	2752	Throttle Position Sensor Low Reference	II	—
37	0.5	BK / GN	469	Manifold Absolute Pressure Sensor Low Reference	II	—
38 - 39	—	—	—	Not Occupied	—	—
40	0.5	BN / BU	357	Oil Temperature Sensor Signal	II	—
41 - 42	—	—	—	Not Occupied	—	—
43	0.5	BK / GY	626	Engine Control Vehicle Sensors Low Reference 1	II	—
44	0.75	VT / BU	5292	Powertrain Main Relay Fused Supply Voltage 3	II	—
45	0.75	GN	4803	Direct Fuel Injector High Voltage Control Cylinder 3	II	—
46	0.75	GY / BU	4804	Direct Fuel Injector High Voltage Control Cylinder 4	II	—
47	0.75	WH / GN	4805	Direct Fuel Injector High Voltage Control Cylinder 5	II	—
48	0.75	VT / GN	4806	Direct Fuel Injector High Voltage Control Cylinder 6	II	—
49	0.75	BU	4802	Direct Fuel Injector High Voltage Control Cylinder 2	II	—
50	0.75	YE / GY	4807	Direct Fuel Injector High Voltage Control Cylinder 7	II	—
51	0.75	GY	4808	Direct Fuel Injector High Voltage Control Cylinder 8	II	—
52	0.75	BN	4801	Direct Fuel Injector High Voltage Control Cylinder 1	II	—
53	0.5	BU / VT	5491	Cylinder Deactivation Solenoid Valve Control 1	II	—
54	0.5	YE	5498	Cylinder Deactivation Solenoid Valve Control 8	II	—
55	0.5	BN / RD	2701	Throttle Position Sensor 5V Reference	II	—
56	0.5	BU / WH	3630	Throttle Position Sensor SENT 1 Signal	II	—
57	0.5	GY / RD	2704	Manifold Absolute Pressure Sensor 5V Reference	II	—
58	0.5	GN / WH	432	Manifold Absolute Pressure Sensor Signal	II	—
59 - 60	—	—	—	Not Occupied	—	—
61	0.5	BU	410	Engine Coolant Temperature Sensor Signal	II	—
62	—	—	—	Not Occupied	—	—
63	0.5	BU / WH	10786	Fuel Rail Pressure Sensor SENT 1 Signal	II	—

**6-382 Electrical Component and Inline Harness Connector End Views****K20 Engine Control Module X3 (L84 / L87) (cont'd)**

Pin	Size	Color	Circuit	Function	Terminal Type ID	Option
64	0.5	GY	23	Generator Field Duty Cycle Signal	II	—
65	0.75	GN / BK	4903	Direct Fuel Injector High Voltage Supply Cylinder 3	II	—
66	0.75	BU / WH	4904	Direct Fuel Injector High Voltage Supply Cylinder 4	II	—
67	0.75	GN / WH	4905	Direct Fuel Injector High Voltage Supply Cylinder 5	II	—
68	0.75	VT / GY	4906	Direct Fuel Injector High Voltage Supply Cylinder 6	II	—
69	0.75	BU / BK	4902	Direct Fuel Injector High Voltage Supply Cylinder 2	II	—
70	0.75	WH / YE	4907	Direct Fuel Injector High Voltage Supply Cylinder 7	II	—
71	0.75	GY / WH	4908	Direct Fuel Injector High Voltage Supply Cylinder 8	II	—
72	0.75	BN / WH	4901	Direct Fuel Injector High Voltage Supply Cylinder 1	II	—
73	2.5	BK / WH	251	Signal Ground	I	—

**K29FV Front Seat Heater Vent Control Module X1 (KA1 & KQV)**

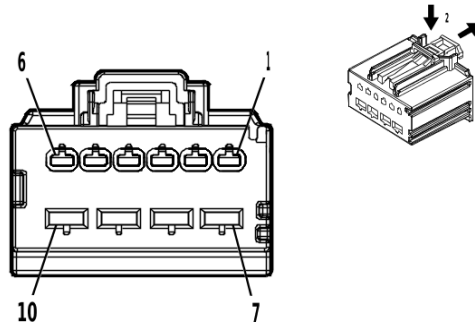

5035058

**Connector Part Information**

Harness Type: Front Seat Wiring Harness - Passenger  
 OEM Connector: 31372-1600  
 Service Connector: Service by Harness - See Part Catalog  
 Description: 10-Way F 1.5, 2.8 MX Series( BK)

**Terminal Part Information**

Terminal Type ID	Terminated Lead	Diagnostic Test Probe	Terminal Removal Tool
I	Not required	J-35616-2A (GY)	No Tool Required
II	Not required	J-35616-4A (PU)	No Tool Required

**K29FV Front Seat Heater Vent Control Module X1 (KA1 & KQV)**

Pin	Size	Color	Circuit	Function	Terminal Type ID	Option
1	0.75	WH / BN	2481	Passenger Seat Back Heating Element Control	I	—
2	0.75	BN / BU	2479	Passenger Seat Heating Element Control	I	—
3	0.75	GY / BK	2480	Passenger Seat Heating Element Low Reference	I	—
4	0.75	BN / BK	2078	Driver Seat Heating Element Low Reference	I	—
5	0.75	BN	2432	Driver Seat Back Heating Element Control	I	—
6	0.75	BN / VT	2077	Driver Seat Heating Element Control	I	—
7	0.75	RD / GN	6140	Battery Positive Voltage	II	—
8	0.75	BK	1350	Ground	II	—
9	—	—	—	Not Occupied	—	—
10	0.75	RD / BN	6640	Battery Positive Voltage	II	—

**K29FV Front Seat Heater Vent Control Module X2 (KA1 & KQV)**

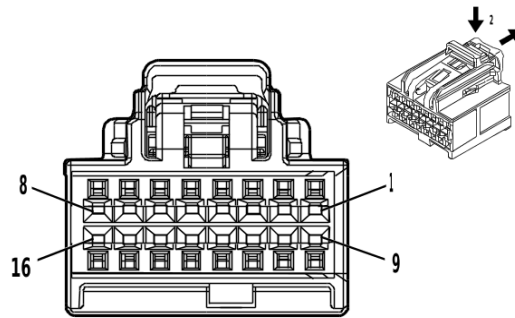

4873243

**Connector Part Information**

Harness Type: Front Seat Wiring Harness - Passenger  
 OEM Connector: 35016343  
 Service Connector: Service by Harness - See Part Catalog  
 Description: 16-Way F 0.64 OCS Series( BK)

**Terminal Part Information**

Terminal Type ID	Terminated Lead	Diagnostic Test Probe	Terminal Removal Tool
I	Not required	J-35616-64B (L-BU)	No Tool Required

**K29FV Front Seat Heater Vent Control Module X2 (KA1 & KQV)**

Pin	Size	Color	Circuit	Function	Terminal Type ID	Option
1	0.5	BK / YE	2080	Driver Heated Seat Thermistor Low Reference	I	—
2	0.5	BK / GY	2435	Passenger Heated Seat Thermistor Low Reference	I	—
3	0.5	BU	2425	Driver Seat Back Heating Temperature Sensor Signal	I	—
4	0.5	WH / BU	2436	Passenger Seat Back Heating Temperature Sensor Signal	I	—
5	0.5	WH / GY	2434	Passenger Seat Heating Temperature Sensor Signal	I	—
6	0.5	YE / GY	2079	Driver Seat Heating Temperature Sensor Signal	I	—
7	—	—	—	Not Occupied	—	—
8	0.5	GN / VT	2857	Body Control Module LIN Bus 11	I	—
9	0.5	GN / VT	5906	Driver Seat Blower Motor Control 1	I	—
10	0.5	VT / WH	5908	Passenger Seat Blower Motor Control 1	I	—
11	—	—	—	Not Occupied	—	—
12	0.5	BK / GN	2482	Passenger Heated Back Thermistor Low Reference	I	—
13 - 16	—	—	—	Not Occupied	—	—

## K29R Rear Seat Heater Control Module X1 (KA6)

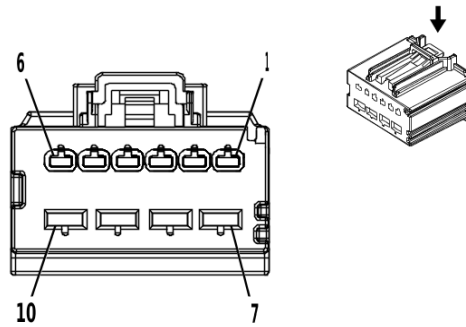

3791446

### Connector Part Information

Harness Type: Rear Seat Heater Control Wiring Harness  
 OEM Connector: 31372-1000  
 Service Connector: Service by Harness - See Part Catalog  
 Description: 10-Way F 1.5, 2.8 MX Series( BK)

### Terminal Part Information

Terminal Type ID	Terminated Lead	Diagnostic Test Probe	Terminal Removal Tool
I	Not required	J-35616-2A (GY)	No Tool Required
II	Not required	J-35616-4A (PU)	No Tool Required

### K29R Rear Seat Heater Control Module X1 (KA6)

Pin	Size	Color	Circuit	Function	Terminal Type ID	Option
1	—	—	—	Not Occupied	—	—
2	0.75	GN / BN	2296	Right Rear Seat Cushion Heating Element Control	I	—
3	0.75	GN / BK	2297	Right Rear Seat Cushion Heating Element Low Reference	I	—
4	0.75	BN / BK	2295	Left Rear Seat Cushion Heating Element Low Reference	I	—
5	—	—	—	Not Occupied	—	—
6	0.75	GY	2294	Left Rear Seat Cushion Heating Element Control	I	—
7	0.75	RD / YE	5740	Battery Positive Voltage	II	—
8	1	BK	1550	Ground	II	—
9	—	—	—	Not Occupied	—	—
10	0.75	RD / VT	6740	Battery Positive Voltage	II	—

**K29R Rear Seat Heater Control Module X2 (KA6)**

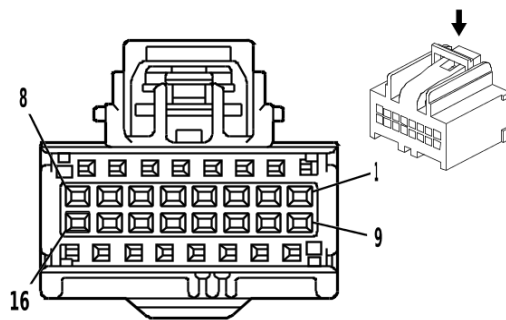

1653409

**Connector Part Information**

Harness Type: Rear Seat Heater Control Wiring Harness  
 OEM Connector: 7283-9076-30  
 Service Connector: Service by Harness - See Part Catalog  
 Description: 16-Way F 0.64 Kaizen Series( BK)

**Terminal Part Information**

Terminal Type ID	Terminated Lead	Diagnostic Test Probe	Terminal Removal Tool
I	Not required	J-35616-64B (L-BU)	No Tool Required

**K29R Rear Seat Heater Control Module X2 (KA6)**

Pin	Size	Color	Circuit	Function	Terminal Type ID	Option
1	0.75	BU / WH	7048	Left Rear Cushion Thermistor Feedback Signal	I	—
2	0.75	WH / BK	7054	Right Rear Cushion Thermistor Feedback Signal	I	—
3 - 4	—	—	—	Not Occupied	—	—
5	0.75	YE / WH	7053	Right Rear Seat Cushion Temperature Sensor Signal	I	—
6	0.75	WH / BU	7047	Left Rear Seat Cushion Temperature Sensor Signal	I	—
7	0.5	BK	1550	Ground	I	—
8	0.5	GN / BU	2857	Body Control Module LIN Bus 11	I	—
9 - 16	—	—	—	Not Occupied	—	—



**K32 Heated Steering Wheel Module X1 (K13 & (D07 / NK5))**

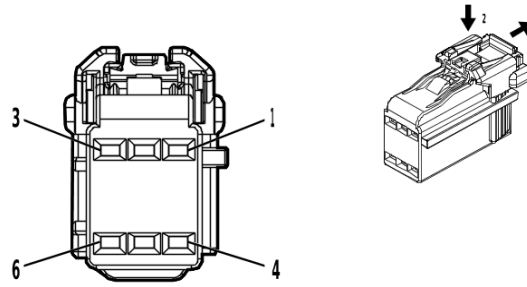

4862126

**Connector Part Information**

Harness Type: Steering Wheel Horn Switch Wiring Harness  
 OEM Connector: 13532426  
 Service Connector: Service by Harness - See Part Catalog  
 Description: 6-Way F 1.2 Series( BK)

**Terminal Part Information**

Terminal Type ID	Terminated Lead	Diagnostic Test Probe	Terminal Removal Tool
I	Not required	J-35616-16 (L-GN)	No Tool Required

**K32 Heated Steering Wheel Module X1 (K13 & (D07 / NK5))**

Pin	Size	Color	Circuit	Function	Terminal Type ID	Option
1	0.35	YE / GY	5883	Steering Wheel Heating Switch Signal	I	—
2	0.35	BN / WH	5884	Steering Wheel Heating Switch LED Control	I	—
3	0.5	RD / GN	10040	Battery Positive Voltage	I	—
4	0.5	BK	6050	Steering Wheel Ground	I	—
5	0.35	BK / WH	6051	Steering Wheel Ground	I	—
6	0.35	GN / BK	2858	Body Control Module LIN Bus 12	I	—

**K32 Heated Steering Wheel Module X1 (KI3 & N57 - D07)**

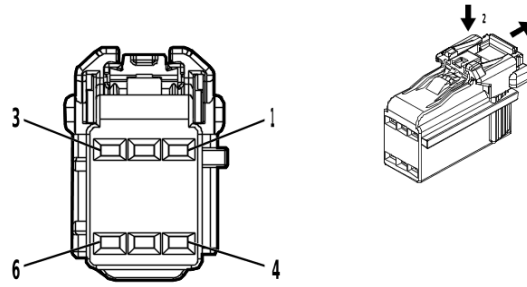

4862126

**Connector Part Information**

Harness Type: Steering Wheel Horn Switch Wiring Harness  
 OEM Connector: 13532426  
 Service Connector: Service by Harness - See Part Catalog  
 Description: 6-Way F 1.2 Series( BK)

**Terminal Part Information**

Terminal Type ID	Terminated Lead	Diagnostic Test Probe	Terminal Removal Tool
I	Not required	J-35616-16 (L-GN)	No Tool Required

**K32 Heated Steering Wheel Module X1 (KI3 & N57 - D07)**

Pin	Size	Color	Circuit	Function	Terminal Type ID	Option
1	0.35	GN	5883	Steering Wheel Heating Switch Signal	I	—
2	0.35	GY / OG	5884	Steering Wheel Heating Switch LED Control	I	—
3	0.5	OG	10040	Battery Positive Voltage	I	—
4	0.5	BK	6050	Steering Wheel Ground	I	—
5	0.35	BK	6051	Steering Wheel Ground	I	—
6	0.35	WH	2858	Body Control Module LIN Bus 12	I	—

**K32 Heated Steering Wheel Module X2 (KI3 - UKL)**

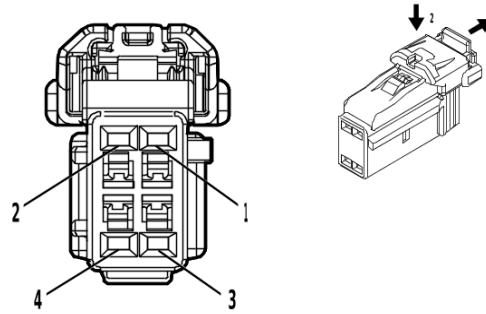

4872683

**Connector Part Information**

Harness Type: Steering Wheel Heater  
 OEM Connector: 13533335  
 Service Connector: Service by Harness - See Part Catalog  
 Description: 4-Way F 1.2 Series( BK)

**Terminal Part Information**

Terminal Type ID	Terminated Lead	Diagnostic Test Probe	Terminal Removal Tool
I	Not required	J-35616-12 (BU)	No Tool Required

**K32 Heated Steering Wheel Module X2 (KI3 - UKL)**

Pin	Size	Color	Circuit	Function	Terminal Type ID	Option
1	0.75	WH / YE	5888	Steering Wheel Heating High Control	I	—
2	0.75	GY / YE	5887	Steering Wheel Heating Low Control	I	—
3	0.35	VT / BU	5886	Steering Wheel Heating Temperature Sensor Signal	I	—
4	0.35	YE / RD	5885	Steering Wheel Heating Voltage Reference	I	—

**K36 Restraints Control Module X1**

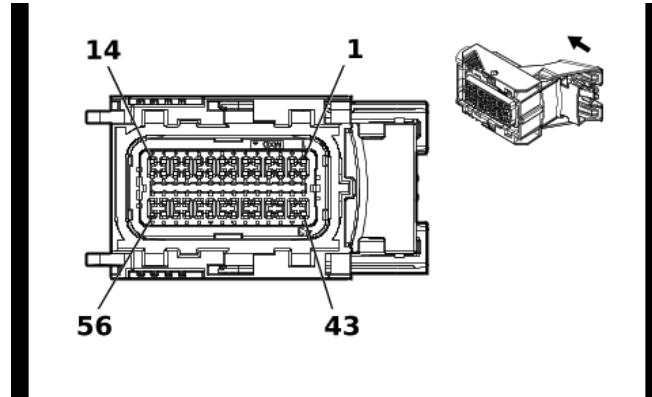

5377109

**Connector Part Information**

Harness Type: Body Wiring Harness  
 OEM Connector: 160099-0030  
 Service Connector: 26314571  
 Description: 56-Way F 0.64 Series, Sealed( BU)

**Terminal Part Information**

Terminal Type ID	Terminated Lead	Diagnostic Test Probe	Terminal Removal Tool
I	19354746	J-35616-64B (L-BU)	J-38125-213
II	19354746	J-35616-64B (L-BU)	J-38125-215A

**K36 Restraints Control Module X1**

Pin	Size	Color	Circuit	Function	Terminal Type ID	Option
1 - 6	—	—	—	Not Occupied	—	—
7	0.5	BK / OG	5045	Left Front Impact Discriminating Sensor Low Reference	II	—
8	0.5	OG / YE	354	Left Front Impact Discriminating Sensor Signal	II	—
9	0.5	OG / GN	1409	Right Front Impact Discriminating Sensor Signal	II	—
10	0.5	BK / OG	5600	Right Front Impact Discriminating Sensor Low Reference	II	—
11	0.5	WH / OG	3476	Passenger Seat Belt Retractor Pretensioner Low Control	I	—
12	0.5	OG / GN	3475	Passenger Seat Belt Retractor Pretensioner High Control	I	—
13	0.35	YE / OG	3025	Passenger Instrument Panel Air Bag Stage 1 High Control	II	—
14	0.35	OG / WH	3024	Passenger Instrument Panel Air Bag Stage 1 Low Control	II	—
15 - 24	—	—	—	Not Occupied	—	—
25	0.5	VT / OG	3478	Driver Seat Belt Retractor Pretensioner Low Control	I	—
26	0.5	OG / WH	3477	Driver Seat Belt Retractor Pretensioner High Control	I	—
27	0.35	OG / VT	3021	Steering Wheel Air Bag Stage 1 High Control	II	—
28	0.35	BN / OG	3020	Steering Wheel Air Bag Stage 1 Low Control	II	—
29	0.5	BU	4987	AUTOSAR CAN Bus [+] 1 Serial Data	II	—
30	0.5	WH	4986	AUTOSAR CAN Bus [-] 1 Serial Data	II	—

**K36 Restraints Control Module X1 (cont'd)**

Pin	Size	Color	Circuit	Function	Terminal Type ID	Option
31	—	—	—	Not Occupied	—	—
32	0.5	OG / BN	3479	Passenger Seat Belt Anchor Pretensioner High Control	I	—
33	0.5	GY / OG	3480	Passenger Seat Belt Anchor Pretensioner Low Control	I	—
34 - 37	—	—	—	Not Occupied	—	—
38	0.35	OG / VT	3026	Passenger Instrument Panel Air Bag Stage 2 Low Control	II	—
39	0.35	GY / OG	3027	Passenger Instrument Panel Air Bag Stage 2 High Control	II	—
40 - 41	—	—	—	Not Occupied	—	—
42	0.5	BK / WH	1251	Signal Ground	II	—
43	0.5	BU	4987	AUTOSAR CAN Bus [+] 1 Serial Data	II	—
44	0.5	WH	4986	AUTOSAR CAN Bus [-] 1 Serial Data	II	—
45	—	—	—	Not Occupied	—	—
46	0.5	VT / OG	3482	Driver Seat Belt Anchor Pretensioner Low Control	I	—
47	0.5	OG / YE	3481	Driver Seat Belt Anchor Pretensioner High Control	I	—
48 - 49	—	—	—	Not Occupied	—	—
50	0.35	BN / WH	3895	Roof Rail Air Bag Disable Switch Low Reference	II	—
51	0.35	BU / WH	3119	Roof Rail Air Bag Disable Switch Signal	II	—
52	—	—	—	Not Occupied	—	—
53	0.35	WH / OG	3022	Steering Wheel Air Bag Stage 2 Low Control	II	—
54	0.35	OG / GN	3023	Steering Wheel Air Bag Stage 2 High Control	II	—
55	0.35	VT / WH	239	Run/Crank Ignition 1 Voltage	II	—
56	0.5	RD / GN	4440	Battery Positive Voltage	II	—

**K36 Restraints Control Module X2**

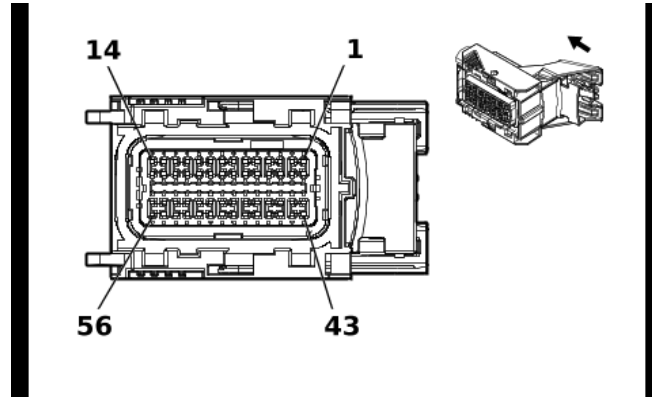

5377124

**Connector Part Information**

Harness Type: Body Wiring Harness  
 OEM Connector: 12683274  
 Service Connector: 85004498  
 Description: 56-Way F 0.64 Series, Sealed( BK)

**Terminal Part Information**

Terminal Type ID	Terminated Lead	Diagnostic Test Probe	Terminal Removal Tool
I	19354746	J-35616-64B (L-BU)	J-38125-213
II	19354746	J-35616-64B (L-BU)	J-38125-215A

**K36 Restraints Control Module X2**

Pin	Size	Color	Circuit	Function	Terminal Type ID	Option
1 - 9	—	—	—	Not Occupied	—	—
10	0.5	BU / OG	5163	Rear Center Seat Belt Switch Signal	II	—
11	0.5	YE / OG	5161	Left Rear Seat Belt Switch Signal	II	—
12	0.35	OG / GY	2652	Driver Seat Belt Sensor Signal	II	—
13	0.5	BK / OG	6627	Right Rear Side Impact Sensor Low Reference	II	—
14	0.5	OG / WH	6626	Right Rear Side Impact Sensor Signal	II	—
15 - 22	—	—	—	Not Occupied	—	—
23	0.5	BK / OG	1363	Driver Seat Belt Switch Low Reference	II	—
24	0.5	BN / OG	5162	Right Rear Seat Belt Switch Signal	II	—
25	0.35	OG / VT	1362	Passenger Seat Belt Switch Signal	II	—
26	—	—	—	Not Occupied	—	—
27	0.5	BK / OG	6628	Left Front Side Impact Sensor Low Reference	II	—
28	0.5	OG / GN	2132	Left Front Side Impact Sensor Signal	II	—
29 - 36	—	—	—	Not Occupied	—	—
37	0.5	OG / GY	5021	Right Front Roof Rail Air Bag High Control	I	—
38	0.5	WH / OG	5022	Right Front Roof Rail Air Bag Low Control	I	—
39	0.5	BU / OG	4957	Passenger Seat Back Air Bag Low Control	II	—
40	0.5	OG / GY	4956	Passenger Seat Back Air Bag High Control	II	—
41	0.5	BK / OG	6629	Right Front Side Impact Sensor Low Reference	II	—
42	0.5	BN / OG	2134	Right Front Side Impact Sensor Signal	II	—
43 - 50	—	—	—	Not Occupied	—	—

**K36 Restraints Control Module X2 (cont'd)**

<b>Pin</b>	<b>Size</b>	<b>Color</b>	<b>Circuit</b>	<b>Function</b>	<b>Terminal Type ID</b>	<b>Option</b>
51	0.5	OG / GN	5019	Left Front Roof Rail Air Bag High Control	I	—
52	0.5	VT / OG	5020	Left Front Roof Rail Air Bag Low Control	I	—
53	0.5	BK / OG	4963	Driver Seat Back Air Bag Low Control	II	—
54	0.5	OG / BU	4962	Driver Seat Back Air Bag High Control	II	—
55	0.5	BK / OG	6623	Left Rear Side Impact Sensor Low Reference	II	—
56	0.5	OG / BU	6622	Left Rear Side Impact Sensor Signal	II	—

**K38 Chassis Control Module (G93 / G94)**

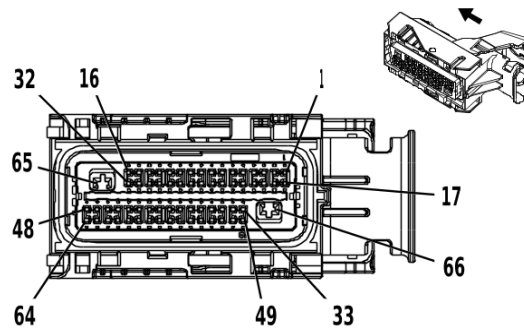

3621452

**Connector Part Information**

Harness Type: Chassis Wiring Harness  
 OEM Connector: 34822-0013  
 Service Connector: 19329822  
 Description: 66-Way F 0.64, 2.8 Series, Sealed( BK with BK Terminal Position Assurance)

**Terminal Part Information**

Terminal Type ID	Terminated Lead	Diagnostic Test Probe	Terminal Removal Tool
I	13587518	J-35616-35 (VT)	J-38125-11A
II	19351723	J-35616-64B (L-BU)	J-38125-213

**K38 Chassis Control Module (G93 / G94)**

Pin	Size	Color	Circuit	Function	Terminal Type ID	Option
1 - 5	—	—	—	Not Occupied	—	—
6	0.5	VT / WH	639	Run/Crank Ignition 1 Voltage	II	—
7 - 12	—	—	—	Not Occupied	—	—
13	0.5	YE / GN	7122	Axle Differential Lock Switch Signal	II	—
14 - 31	—	—	—	Not Occupied	—	—
32	0.5	VT / GY	7117	Front Axle Differential Lock Indicator Control	II	—
33	0.75	VT / WH	7256	Front Differential Lock Actuator Control	II	—
34	0.5	BU / YE	4979	AUTOSAR CAN Bus [+] 2 Serial Data	II	—
35	0.5	BU / YE	4979	AUTOSAR CAN Bus [+] 2 Serial Data	II	—
36	0.5	WH	4978	AUTOSAR CAN Bus [-] 2 Serial Data	II	—
37	0.5	WH	4978	AUTOSAR CAN Bus [-] 2 Serial Data	II	—
38	0.5	YE	7115	Rear Axle Differential Lock Indicator Control	II	—
39 - 43	—	—	—	Not Occupied	—	—
44	0.75	GY / BK	7253	Rear Differential Lock Actuator Low Control	II	—
45 - 49	—	—	—	Not Occupied	—	—
50	0.75	VT / BN	7258	Rear Differential Lock Actuator Control	II	—
51 - 59	—	—	—	Not Occupied	—	—
60	0.75	WH / BK	7254	Front Differential Lock Actuator Low Control	II	—
61 - 64	—	—	—	Not Occupied	—	—
65	1.5	BK	1850	Ground	I	—
66	1.5	RD / WH	5940	Battery Positive Voltage	I	—



## K40D Driver Seat Adjuster Memory Module X1

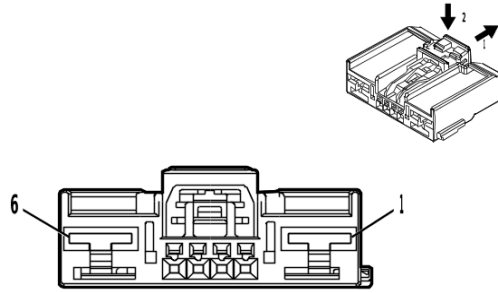

4650258

### Connector Part Information

Harness Type: Front Seat Wiring Harness - Driver  
 OEM Connector: 7289-7139-30  
 Service Connector: Service by Harness - See Part Catalog  
 Description: 6-Way F 0.64, 6.3 Series( BK)

### Terminal Part Information

Terminal Type ID	Terminated Lead	Diagnostic Test Probe	Terminal Removal Tool
I	Not required	J-35616-42 (RD)	No Tool Required
II	Not required	J-35616-64B (L-BU)	No Tool Required

### K40D Driver Seat Adjuster Memory Module X1

Pin	Size	Color	Circuit	Function	Terminal Type ID	Option
1	2.5	BK	1550	Ground	I	—
2	—	—	—	Not Occupied	—	—
3	0.5	RD / BN	2240	Battery Positive Voltage	II	—
4 - 5	—	—	—	Not Occupied	—	—
6	2.5	RD / YE	5040	Battery Positive Voltage	I	—

**K40D Driver Seat Adjuster Memory Module X2**

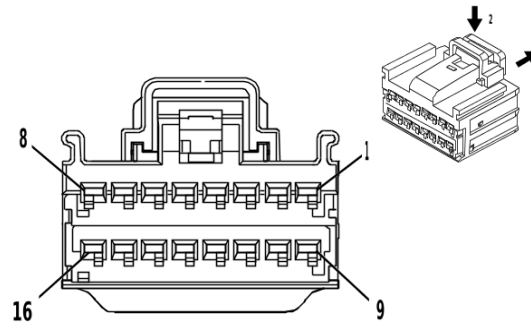

4332214

**Connector Part Information**

Harness Type: Front Seat Wiring Harness - Driver  
 OEM Connector: 15512506  
 Service Connector: Service by Harness - See Part Catalog  
 Description: 16-Way F 1.5 OCS Series( BK)

**Terminal Part Information**

Terminal Type ID	Terminated Lead	Diagnostic Test Probe	Terminal Removal Tool
I	Not required	J-35616-14 (GN)	No Tool Required

**K40D Driver Seat Adjuster Memory Module X2**

Pin	Size	Color	Circuit	Function	Terminal Type ID	Option
1	1.5	YE / BU	285	Driver Seat Horizontal Motor Forward Control	I	—
2	—	—	—	Not Occupied	—	—
3	1.5	GN / YE	276	Driver Seat Recline Motor Forward Control	I	—
4 - 5	—	—	—	Not Occupied	—	—
6	1.5	BU / VT	287	Driver Seat Front Vertical Motor Down Control	I	—
7	1.5	YE	282	Driver Seat Rear Vertical Motor Up Control	I	—
8	—	—	—	Not Occupied	—	—
9	1.5	BU / YE	277	Driver Seat Recline Motor Rearward Control	I	—
10	—	—	—	Not Occupied	—	—
11	1.5	GY / GN	284	Driver Seat Horizontal Motor Rearward Control	I	—
12	—	—	—	Not Occupied	—	—
13	1.5	GY / BU	283	Driver Seat Rear Vertical Motor Down Control	I	—
14 - 15	—	—	—	Not Occupied	—	—
16	1.5	GN / BN	286	Driver Seat Front Vertical Motor Up Control	I	—

## K40D Driver Seat Adjuster Memory Module X3

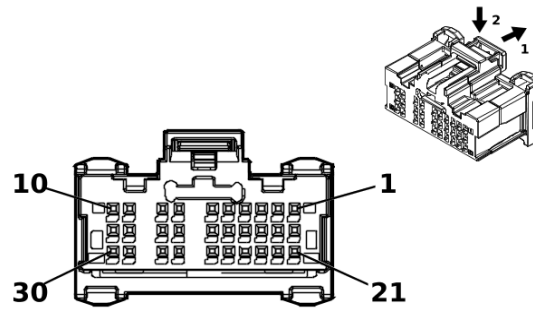

5202284

### Connector Part Information

Harness Type: Front Seat Wiring Harness - Driver  
 OEM Connector: 2309644-1  
 Service Connector: Service by Harness - See Part Catalog  
 Description: 30-Way F 0.5 MQS Series( BK)

### Terminal Part Information

Terminal Type ID	Terminated Lead	Diagnostic Test Probe	Terminal Removal Tool
I	Not required	EL-35616-58 (BK)	No Tool Required

### K40D Driver Seat Adjuster Memory Module X3

Pin	Size	Color	Circuit	Function	Terminal Type ID	Option
1	—	—	—	Not Occupied	—	—
2	0.35	BU / GN	614	Seat Memory Switch Set Signal	I	—
3 - 4	—	—	—	Not Occupied	—	—
5	0.35	BN	3038	Driver Seat Right Rear Haptic Movement Motor Control	I	—
6	0.35	YE / BN	3037	Driver Seat Left Rear Haptic Movement Motor Control	I	—
7	—	—	—	Not Occupied	—	—
8	0.35	GN / WH	7530	Driver Seat Adjuster Memory Module LIN Bus 1	I	—
9	0.35	WH	4100	AUTOSAR CAN Bus [-] 4 Serial Data	I	—
10	0.35	BU / VT	4101	AUTOSAR CAN Bus [+] 4 Serial Data	I	—
11 - 15	—	—	—	Not Occupied	—	—
16	0.35	WH	615	Seat Memory Switch Signal 1	I	—
17	—	—	—	Not Occupied	—	—
18	0.35	GN / GY	3758	Driver Seat Adjuster Memory Module LIN Bus 2	I	—
19	0.35	WH	4100	AUTOSAR CAN Bus [-] 4 Serial Data	I	—
20	0.35	BU / VT	4101	AUTOSAR CAN Bus [+] 4 Serial Data	I	—
21 - 30	—	—	—	Not Occupied	—	—

**K43 Power Steering Control Module X1**

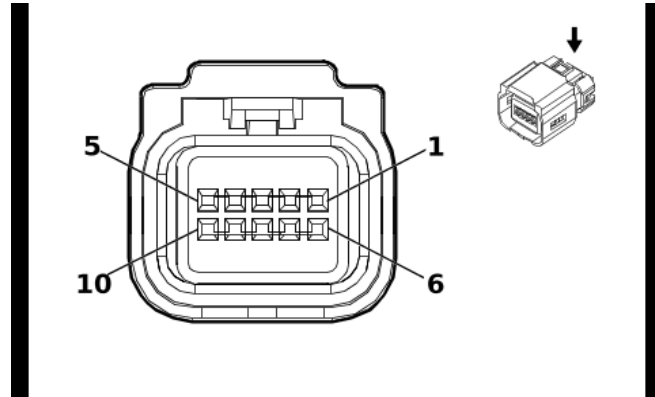

5924496

**Connector Part Information**

Harness Type: Power Steering Wiring Harness Extension Harness  
 OEM Connector: 13529266  
 Service Connector: Service by Harness - See Part Catalog  
 Description: 10-Way F 0.64 Kaizen Series, Sealed( GN)

**Terminal Part Information**

Terminal Type ID	Terminated Lead	Diagnostic Test Probe	Terminal Removal Tool
I	Not required	J-35616-64B (L-BU)	No Tool Required

**K43 Power Steering Control Module X1**

Pin	Size	Color	Circuit	Function	Terminal Type ID	Option
1 - 6	—	—	—	Not Occupied	—	—
7	0.5	WH / BU	4987	AUTOSAR CAN Bus [+] 1 Serial Data	I	—
8	0.5	GY / WH	4986	AUTOSAR CAN Bus [-] 1 Serial Data	I	—
9 - 10	—	—	—	Not Occupied	—	—

## K43 Power Steering Control Module X2

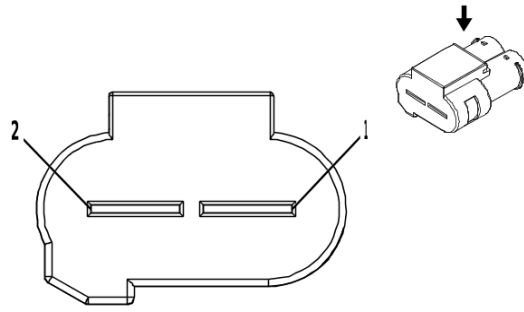

3608474

### Connector Part Information

Harness Type: Power Steering Control Module Wiring Harness  
 OEM Connector: 13598847  
 Service Connector: Service by Harness - See Part Catalog  
 Description: 2-Way

### Terminal Part Information

Terminal Type ID	Terminated Lead	Diagnostic Test Probe	Terminal Removal Tool
I	Not required	No Tool Required	No Tool Required

### K43 Power Steering Control Module X2

Pin	Size	Color	Circuit	Function	Terminal Type ID	Option
1	20	RD	3542	Battery Positive Voltage	I	—
2	20	BK	350	Ground	I	—

### K43 Power Steering Control Module X3

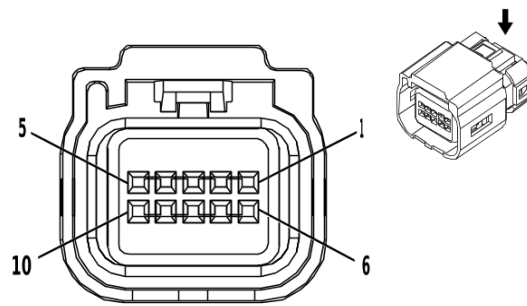

3608468

#### Connector Part Information

Harness Type: Power Steering Control Module Wiring Harness - Shaft Sensor  
 OEM Connector: 13587226  
 Service Connector: Service by Harness - See Part Catalog  
 Description: 10-Way F 0.64 Kaizen Series, Sealed( BN)

#### Terminal Part Information

Terminal Type ID	Terminated Lead	Diagnostic Test Probe	Terminal Removal Tool
I	Not required	J-35616-64B (L-BU)	No Tool Required

#### K43 Power Steering Control Module X3

Pin	Size	Color	Circuit	Function	Terminal Type ID	Option
1	0.5	BU	8367	Handwheel Channel A Torque Pressure Sensor 1 SENT Signal	I	—
2	0.5	RD	8366	Handwheel Channel A High Reference	I	—
3	0.5	BK	8370	Handwheel Channel A Low Reference	I	—
4	0.5	WH / RD	8371	Handwheel Channel B High Reference	I	—
5	0.5	WH / BU	8372	Handwheel Channel B Torque Pressure Sensor 1 SENT Signal	I	—
6	0.5	VT	8368	Handwheel Channel A Torque Pressure Sensor 2 SENT Signal	I	—
7	0.5	OG	8369	Handwheel Channel A Angle Position Sensor SENT Signal	I	—
8	0.5	GY	8375	Handwheel Channel B Low Reference	I	—
9	0.5	YE	8374	Handwheel Channel B Angle Position Sensor SENT Signal	I	—
10	0.5	GN	8373	Handwheel Channel B Torque Pressure Sensor 2 SENT Signal	I	—

## K56 Serial Data Gateway Module X1

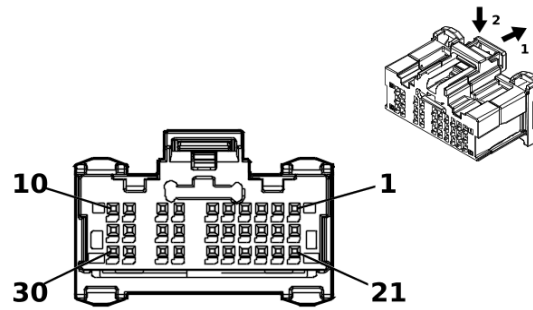

5202284

### Connector Part Information

Harness Type: Instrument Panel Wiring Harness  
 OEM Connector: 2309644-1  
 Service Connector: 84766507  
 Description: 30-Way F 0.5 MQS Series( BK)

### Terminal Part Information

Terminal Type ID	Terminated Lead	Diagnostic Test Probe	Terminal Removal Tool
I	19370262	EL-35616-58 (BK)	EL-38125-58
II	Not required	No Tool Required	No Tool Required
III	Service by Cable	No Tool Required	No Tool Required

### K56 Serial Data Gateway Module X1

Pin	Size	Color	Circuit	Function	Terminal Type ID	Option
1	0.35	RD / BN	4940	Battery Positive Voltage	I	—
2	0.35	BU / GN	4105	AUTOSAR CAN Bus [+] 8 Serial Data	I	—
3	0.35	WH / YE	4104	AUTOSAR CAN Bus [-] 8 Serial Data	I	—
4	0.35	BK / WH	851	Signal Ground	I	—
5	0.35	BU / BN	4987	AUTOSAR CAN Bus [+] 1 Serial Data	I	—
6	0.35	WH / RD	4986	AUTOSAR CAN Bus [-] 1 Serial Data	I	—
7	0.35	WH	4100	AUTOSAR CAN Bus [-] 4 Serial Data	I	—
8	0.35	BU / VT	4101	AUTOSAR CAN Bus [+] 4 Serial Data	I	—
9	0.35	WH	4976	AUTOSAR CAN Bus [-] 3 Serial Data	I	—
10	0.35	BU / BK	4977	AUTOSAR CAN Bus [+] 3 Serial Data	I	—
11 - 12	—	—	—	Not Occupied	—	—
13	0.35	WH / GY	4104	AUTOSAR CAN Bus [-] 8 Serial Data	I	—
14	0.35	BU / GY	4105	AUTOSAR CAN Bus [+] 8 Serial Data	I	—
15	0.35	BU / BN	4987	AUTOSAR CAN Bus [+] 1 Serial Data	I	—
16	— 0.35	WH WH / RD	4986 4986	AUTOSAR CAN Bus [-] 1 Serial Data AUTOSAR CAN Bus [-] 1 Serial Data	II I	— —
17	0.35	WH / BN	4978	AUTOSAR CAN Bus [-] 2 Serial Data	I	—
18	0.35	BU / RD	4979	AUTOSAR CAN Bus [+] 2 Serial Data	I	—
19	0.35	BU / GY	4984	AUTOSAR CAN Bus [-] 5 Serial Data	I	—
20	0.35	BU / WH	4985	AUTOSAR CAN Bus [+] 5 Serial Data	I	—

**6-402 Electrical Component and Inline Harness Connector End Views****K56 Serial Data Gateway Module X1 (cont'd)**

Pin	Size	Color	Circuit	Function	Terminal Type ID	Option
21	0.35	GN	7209	Ethernet Bus 3 [+]	III	—
22	0.35	BU	7208	Ethernet Bus 3 [-]	III	—
23 - 24	—	—	—	Not Occupied	—	—
25	0.35	BU / BK	4987	AUTOSAR CAN Bus [+] 1 Serial Data	I	—
26	0.35	WH / YE	4986	AUTOSAR CAN Bus [-] 1 Serial Data	I	—
27	0.35	WH	4978	AUTOSAR CAN Bus [-] 2 Serial Data	I	UKL
	0.35	WH / BN	4978	AUTOSAR CAN Bus [-] 2 Serial Data	I	- UKL
28	0.35	BU / YE	4979	AUTOSAR CAN Bus [+] 2 Serial Data	I	UKL
	0.35	BU / GN	4979	AUTOSAR CAN Bus [+] 2 Serial Data	I	- UKL
29	0.35	BU / OG	4984	AUTOSAR CAN Bus [-] 5 Serial Data	I	—
30	0.35	BU / WH	4985	AUTOSAR CAN Bus [+] 5 Serial Data	I	—



## K56 Serial Data Gateway Module X2

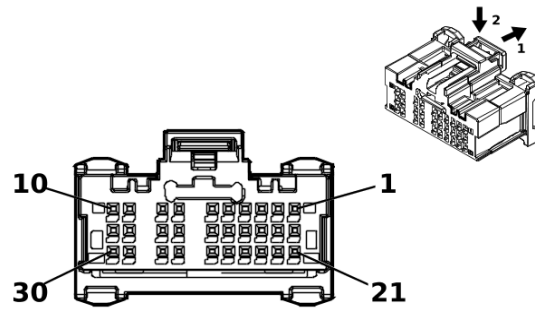

5203942

### Connector Part Information

Harness Type: Instrument Panel Wiring Harness  
 OEM Connector: 2309644-2  
 Service Connector: 84766509  
 Description: 30-Way F 0.5 MQS Series( BK with L-GY Front Housing)

### Terminal Part Information

Terminal Type ID	Terminated Lead	Diagnostic Test Probe	Terminal Removal Tool
I	19370262	EL-35616-58 (BK)	EL-38125-58
II	Service by Cable	No Tool Required	No Tool Required

### K56 Serial Data Gateway Module X2

Pin	Size	Color	Circuit	Function	Terminal Type ID	Option
1 - 4	—	—	—	Not Occupied	—	—
5	0.35	BK / GY	3559	Passive Start Switch 2 Low Reference	I	—
6	—	—	—	Not Occupied	—	—
7	0.35	GN / VT	5199	Run/Crank Relay Coil Control	I	—
8	—	—	—	Not Occupied	—	—
9	0.35	BU	4973	Ethernet Bus 1R [+]	II	—
10	0.35	YE	4972	Ethernet Bus 1R [-]	II	—
11 - 12	—	—	—	Not Occupied	—	—
13	0.35	BU / BN	4983	AUTOSAR CAN Bus [+] 7 Serial Data	I	—
14	0.35	WH	4982	AUTOSAR CAN Bus [-] 7 Serial Data	I	—
15	0.35	GN / BK	3558	Passive Start Switch Signal 2	I	—
16	0.35	WH	4980	AUTOSAR CAN Bus [-] 6 Serial Data	I	—
17	0.35	GN	2578	Private Serial Data Presentation CAN Bus [+] 1 Serial Data	I	—
18	0.35	BN	2577	Private Serial Data Presentation CAN Bus [-] 1 Serial Data	I	—
19	0.35	WH	7207	Ethernet Bus 1 Enable Signal	I	—
20 - 22	—	—	—	Not Occupied	—	—
23	0.35	BU / WH	4985	AUTOSAR CAN Bus [+] 5 Serial Data	I	—
24	0.35	BU / YE	4984	AUTOSAR CAN Bus [-] 5 Serial Data	I	—
25	—	—	—	Not Occupied	—	—
26	0.35	YE	4981	AUTOSAR CAN Bus [+] 6 Serial Data	I	—

**6-404 Electrical Component and Inline Harness Connector End Views****K56 Serial Data Gateway Module X2 (cont'd)**

<b>Pin</b>	<b>Size</b>	<b>Color</b>	<b>Circuit</b>	<b>Function</b>	<b>Terminal Type ID</b>	<b>Option</b>
27	0.35	VT	2580	Private Serial Data Presentation CAN Bus [+] 2 Serial Data	I	—
28	0.35	GY	2579	Private Serial Data Presentation CAN Bus [-] 2 Serial Data	I	—
29	0.35	WH	4975	Ethernet Bus 1T [+]	II	—
30	0.35	GN	4974	Ethernet Bus 1T [-]	II	—

## K56 Serial Data Gateway Module X3

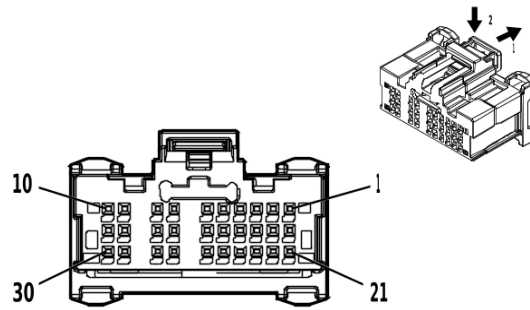

4900333

### Connector Part Information

Harness Type: Instrument Panel Wiring Harness  
 OEM Connector: 2309644-3  
 Service Connector: 13519319  
 Description: 30-Way F 0.5 MQS Series( BK with D-GY Front Housing)

### Terminal Part Information

Terminal Type ID	Terminated Lead	Diagnostic Test Probe	Terminal Removal Tool
I	Service by Cable	No Tool Required	No Tool Required

### K56 Serial Data Gateway Module X3

Pin	Size	Color	Circuit	Function	Terminal Type ID	Option
1 - 6	—	—	—	Not Occupied	—	—
7	0.35	YE	4758	Ethernet Bus 2 [+]	I	IOK
	0.35	BN	7211	Ethernet Bus 4 [+]	I	IOR/ UDA/ UE1
8	0.35	BU	4757	Ethernet Bus 2 [-]	I	IOK
	0.35	GY	7210	Ethernet Bus 4 [-]	I	IOR/ UDA/ UE1
9	0.35	YE	4758	Ethernet Bus 2 [+]	I	—
10	0.35	BU	4757	Ethernet Bus 2 [-]	I	—
11 - 26	—	—	—	Not Occupied	—	—
27	0.35	GN	7217	Ethernet Bus 7 [+]	I	—
28	0.35	WH	7216	Ethernet Bus 7 [-]	I	—
29 - 30	—	—	—	Not Occupied	—	—

**K60 Column Lock Module**

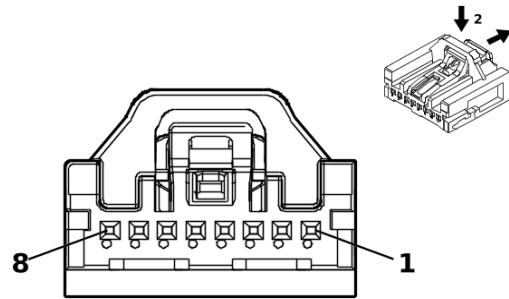

5200269

**Connector Part Information**

Harness Type: Instrument Panel Wiring Harness  
 OEM Connector: 35068228  
 Service Connector: 84769201  
 Description: 8-Way F Mini 50 Series( BK)

**Terminal Part Information**

Terminal Type ID	Terminated Lead	Diagnostic Test Probe	Terminal Removal Tool
I	Not required	EL-35616-58 (BK)	No Tool Required
II	Not required	No Tool Required	No Tool Required

**K60 Column Lock Module**

Pin	Size	Color	Circuit	Function	Terminal Type ID	Option
1	0.35	RD / BN	4940	Battery Positive Voltage	I	—
2	—	—	—	Not Occupied	—	—
3	0.35	BK / WH	851	Signal Ground	I	—
4	0.35	BU	4987	AUTOSAR CAN Bus [+] 1 Serial Data	I	—
5	—	BU	4987	AUTOSAR CAN Bus [+] 1 Serial Data	II	—
	0.35	BU / BN	4987	AUTOSAR CAN Bus [+] 1 Serial Data	I	—
6	0.35	WH	4986	AUTOSAR CAN Bus [-] 1 Serial Data	I	—
7	—	WH	4986	AUTOSAR CAN Bus [-] 1 Serial Data	II	—
	0.35	WH / RD	4986	AUTOSAR CAN Bus [-] 1 Serial Data	I	—
8	0.35	BU / VT	807	Ignition Off/Accessory Ignition Voltage	I	—

### K61 Sunroof Control Module (CF5)

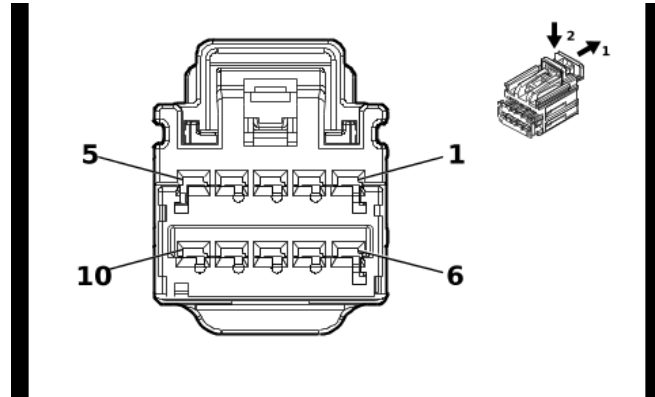

6153939

#### Connector Part Information

Harness Type: Sunroof Wiring Harness  
 OEM Connector: 15512475  
 Service Connector: Service by Harness - See Part Catalog  
 Description: 10-Way F 1.5 OCS Series( BK)

#### Terminal Part Information

Terminal Type ID	Terminated Lead	Diagnostic Test Probe	Terminal Removal Tool
I	Not required	J-35616-2A (GY)	No Tool Required

#### K61 Sunroof Control Module (CF5)

Pin	Size	Color	Circuit	Function	Terminal Type ID	Option
1 - 5	—	—	—	Not Occupied	—	—
6	0.35	GN / WH	2854	Body Control Module LIN Bus 8	I	—
7	—	—	—	Not Occupied	—	—
8	1.5	RD / BN	4540	Battery Positive Voltage	I	—
9	—	—	—	Not Occupied	—	—
10	1.5	BK	1050	Ground	I	—

**K67 Trailer Brake Control Module (JL1)**

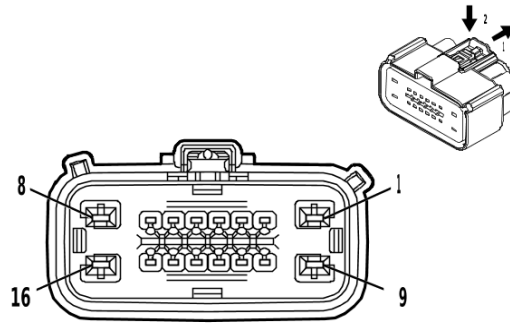

4624589

**Connector Part Information**

Harness Type: Chassis Wiring Harness  
 OEM Connector: 34985-4016  
 Service Connector: 13599889  
 Description: 16-Way F 1.5, 2.8 MX Series, Sealed( GY)

**Terminal Part Information**

Terminal Type ID	Terminated Lead	Diagnostic Test Probe	Terminal Removal Tool
I	13576377	J-35616-35 (VT)	J-38125-12A
II	85528055	J-35616-2A (GY)	J-38125-217

**K67 Trailer Brake Control Module (JL1)**

Pin	Size	Color	Circuit	Function	Terminal Type ID	Option
1	2.5	RD / BN	3640	Battery Positive Voltage	I	—
2	0.5	WH / BK	2223	Trailer Brake Apply Signal	II	—
3 - 4	—	—	—	Not Occupied	—	—
5	0.5	YE / BK	2224	Trailer Brake Enable Signal	II	—
6 - 7	—	—	—	Not Occupied	—	—
8	2.5	BU	47	Trailer Auxiliary Control	I	—
9	2.5	BK	1850	Ground	I	—
10 - 11	—	—	—	Not Occupied	—	—
12	0.5	GN / BU	2733	Brake System Control Module LIN Bus 2	II	—
13 - 16	—	—	—	Not Occupied	—	—

## K68 Trailer Lamp Control Module (UET)

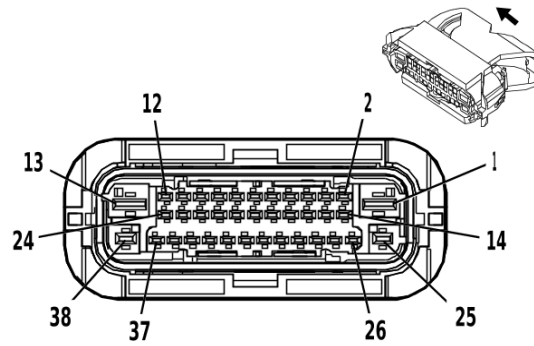

5141918

### Connector Part Information

Harness Type: Chassis Wiring Harness  
 OEM Connector: 35497871  
 Service Connector: 86825459  
 Description: 38-Way F 1.5, 2.8, 4.8 MCP Series, Sealed( BK with BN Inner Connector)

### Terminal Part Information

Terminal Type ID	Terminated Lead	Diagnostic Test Probe	Terminal Removal Tool
I	19368624	J-35616-35 (VT)	J-38125-212
II	19369235	J-35616-14 (GN)	EL-38125-560A
III	85158596	J-35616-40 (BU)	EL-38125-560A

### K68 Trailer Lamp Control Module (UET)

Pin	Size	Color	Circuit	Function	Terminal Type ID	Option
1	2.5	RD / VT	5640	Battery Positive Voltage	III	—
2	1	YE	1618	Left Rear Trailer Stop/Turn Lamp Control	II	—
3	1	GN	1619	Right Rear Trailer Stop/Turn Lamp Control	II	—
4 - 6	—	—	—	Not Occupied	—	—
7	1	GY	5189	Trailer Backup Lamp Control	II	—
8 - 9	—	—	—	Not Occupied	—	—
10	0.35	VT / WH	639	Run/Crank Ignition 1 Voltage	II	—
11	0.5	BN / YE	820	Center High Mounted Stop Lamp Supply Voltage	II	—
12	—	—	—	Not Occupied	—	—
13	2.5	BK	1750	Ground	III	—
14 - 24	—	—	—	Not Occupied	—	—
25	1	BN	2109	Trailer Park Lamp Control	I	—
26	—	—	—	Not Occupied	—	—
27	0.5	BU / VT	4101	AUTOSAR CAN Bus [+] 4 Serial Data	II	—
28	0.5	WH	4100	AUTOSAR CAN Bus [-] 4 Serial Data	II	—
29	0.5	BU / VT	4101	AUTOSAR CAN Bus [+] 4 Serial Data	II	—
30	0.5	WH	4100	AUTOSAR CAN Bus [-] 4 Serial Data	II	—
31 - 37	—	—	—	Not Occupied	—	—
38	2.5	RD / YE	5840	Battery Positive Voltage	I	—

**K69 Transfer Case Control Module (NP0 / NQH)**

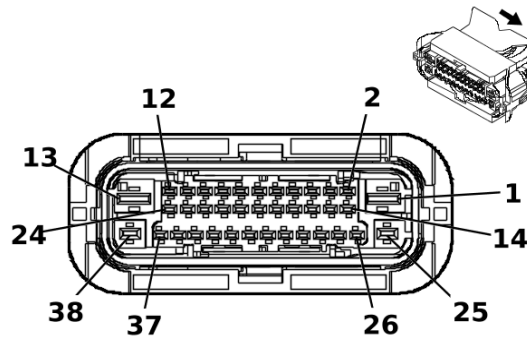

5199340

**Connector Part Information**

Harness Type: Engine Wiring Harness  
 OEM Connector: 35497867  
 Service Connector: 86825458  
 Description: 38-Way F 1.5, 2.8, 4.8 MCP Series, Sealed( BK with BN Inner Connector)

**Terminal Part Information**

Terminal Type ID	Terminated Lead	Diagnostic Test Probe	Terminal Removal Tool
I	19368624	J-35616-35 (VT)	J-38125-212
II	19369235	J-35616-14 (GN)	EL-38125-560A
III	85158596	J-35616-40 (BU)	EL-38125-560A

**K69 Transfer Case Control Module (NP0 / NQH)**

Pin	Size	Color	Circuit	Function	Terminal Type ID	Option
1	3	GN / RD	6042	Cruise Control Switch 5V Reference	III	—
2	—	—	—	Not Occupied	—	—
3	0.5	BU / YE	4979	AUTOSAR CAN Bus [+] 2 Serial Data	II	—
4	0.5	WH	4978	AUTOSAR CAN Bus [-] 2 Serial Data	II	—
5	0.5	WH / GN	7479	Rotary Position Sensor Signal	II	—
6	—	—	—	Not Occupied	—	—
7	0.5	YE	7474	Incremental Encoder Direction Signal	II	—
8	—	—	—	Not Occupied	—	—
9	0.5	YE / WH	1695	4WD Locked Range Indicator Control	II	—
10	—	—	—	Not Occupied	—	—
11	0.5	VT / GY	8017	Secondary Axle Motor Relay Control	II	—
12	0.5	GY / BK	1570	Front Axle Actuator Control	II	—
13	4	YE / VT	1553	Transfer Case Motor Counter Clockwise Control	III	—
14	—	—	—	Not Occupied	—	—
15	0.5	BU / YE	4979	AUTOSAR CAN Bus [+] 2 Serial Data	II	—
16	0.5	WH	4978	AUTOSAR CAN Bus [-] 2 Serial Data	II	—
17	—	—	—	Not Occupied	—	—
18	0.5	VT / GN	439	Run/Crank Ignition 1 Voltage	II	—
19	0.5	BU / GY	7473	Incremental Encoder Impulse Signal	II	—
20	0.5	WH / RD	7477	Gear Position Sensor 5V Reference	II	—



**K69 Transfer Case Control Module (NP0 / NQH) (cont'd)**

Pin	Size	Color	Circuit	Function	Terminal Type ID	Option
21 - 23	—	—	—	Not Occupied	—	—
24	0.5	GN	8015	Transfer Case Motor Low Reference	II	—
25	2.5	BK	450	Ground	I	—
26	—	—	—	Not Occupied	—	—
27	0.5	GN	8014	Transfer Case Lock Solenoid Low Reference	II	—
28 - 29	—	—	—	Not Occupied	—	—
30	0.5	YE / BK	7478	Gear Position Sensor Low Reference	II	—
31	0.5	WH / GN	7475	Incremental Encoder Sensor Voltage Reference	II	—
32	—	—	—	Not Occupied	—	—
33	0.75	BU	8013	Transfer Case Lock Solenoid Control 2	II	—
34	0.75	YE / BN	1569	Transfer Case Lock Solenoid Valve Control	II	—
35	—	—	—	Not Occupied	—	—
36	0.5	VT	7476	Incremental Encoder Sensor Low Reference	II	—
37	—	—	—	Not Occupied	—	—
38	2.5	YE / GY	1552	Transfer Case Motor Clockwise Control	I	—

**K71 Transmission Control Module**

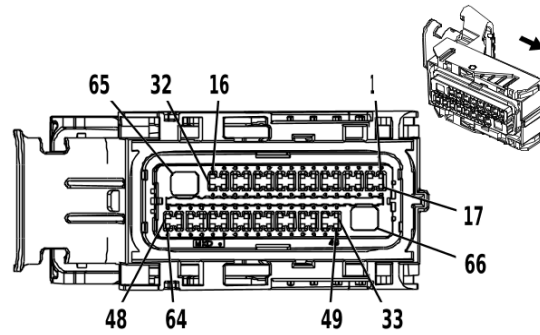

4024881

**Connector Part Information**

Harness Type: Engine Wiring Harness  
 OEM Connector: 34822-0023  
 Service Connector: 19330900  
 Description: 66-Way F 0.64, 2.8 Series, Sealed( BK with BK Terminal Position Assurance)

**Terminal Part Information**

Terminal Type ID	Terminated Lead	Diagnostic Test Probe	Terminal Removal Tool
I	13587518	J-35616-35 (VT)	J-38125-11A
II	19351723	J-35616-64B (L-BU)	J-38125-213
III	Not required	No Tool Required	No Tool Required

**K71 Transmission Control Module**

Pin	Size	Color	Circuit	Function	Terminal Type ID	Option
1	0.5	WH / BU	4507	Transmission Clutch H Control	II	L3B
	0.5	VT / WH	422	Torque Converter Clutch Solenoid Valve Control	II	L84 / L87 / LZ0
2	0.5	BU	6401	Clutch Solenoid Valve B Control	II	L3B
	0.5	GY / GN	6403	Clutch Solenoid Valve D Control	II	L84 / L87 / LZ0
3	0.5	GN / WH	1530	Transmission Line Pressure Control Solenoid Valve Control	II	L3B
	0.5	WH / BU	4507	Transmission Clutch H Control	II	L84 / L87 / LZ0
4	0.5	WH	4508	Transmission Clutch G Control	II	—
5	0.5	GY / RD	10817	Lubricant Circuit Pressure Sensor 5 Volt Reference	II	—
6	—	—	—	Not Occupied	—	—
7	0.5	YE / GN	4170	Transmission Output Shaft Speed Sensor Circuit 9V Reference	II	—
8	0.5	YE / BU	4171	Transmission Input Shaft Speed Sensor Circuit 9V Reference	II	—
9 - 10	—	—	—	Not Occupied	—	—
11	0.5	BU / BK	10819	Lubricant Circuit Pressure Sensor Low Reference	II	—
12	0.5	GN / YE	6353	Input Speed Signal	II	—
13	0.5	GN / VT	4510	Transmission Intermediate Speed Signal	II	—
14	0.5	GY / BU	6358	Output Speed Signal	II	—

**K71 Transmission Control Module (cont'd)**

Pin	Size	Color	Circuit	Function	Terminal Type ID	Option
15	—	BK / BU	6253	Transmission Input Speed Sensor Ground	III	—
	0.5	GN / YE	6353	Input Speed Signal	II	L3B
	0.5	BN / WH	6254	Transmission Input Speed Sensor Signal	II	L84 / L87 / LZ0
16	—	—	—	Not Occupied	—	—
17	0.5	WH	4508	Transmission Clutch G Control	II	L3B
	0.5	GN / WH	1530	Transmission Line Pressure Control Solenoid Valve Control	II	L84 / L87 / LZ0
18	0.5	BN	6400	Clutch Solenoid Valve A Control	II	L3B
	0.5	YE / BN	6404	Clutch Solenoid Valve E Control	II	L84 / L87 / LZ0
19	0.5	GY	6402	Clutch Solenoid Valve C Control	II	—
20	0.5	VT / WH	422	Torque Converter Clutch Solenoid Valve Control	II	L3B
	0.5	VT	4509	Transmission Clutch F Control	II	L84 / L87 / LZ0
21	0.5	GN / WH	6380	Torque Converter Clutch Enable Solenoid Valve A Control	II	L3B
	0.5	WH / YE	2159	Park Inhibit Solenoid Assembly Control	II	L84 / L87 / LZ0
22	0.5	YE / BN	6210	Torque Converter Clutch Enable Solenoid Valve B Control	II	L3B
	0.5	GN / BK	7819	Default Disable Solenoid Control	II	L84 / L87 / LZ0
23	—	—	—	Not Occupied	—	—
24	—	WH / GY	4578	Surge Accumulator Solenoid Valve Low Side Control	III	—
	0.5	GN / WH	2968	Transmission Auxiliary Fluid Pump Control	II	—
25 - 27	—	—	—	Not Occupied	—	—
28	0.5	BK / BN	586	Transmission Fluid Temperature Sensor Low Reference	II	—
29 - 30	—	—	—	Not Occupied	—	—
31	0.5	GN / VT	4621	Engine Control Module LIN Bus 1	II	—
32	—	—	—	Not Occupied	—	—
33	0.5	GN / GY	6387	Transmission High Side Driver 1 Control	II	—
34	—	—	—	Not Occupied	—	—
35	0.5	VT / GN	439	Run/Crank Ignition 1 Voltage	II	—
36	—	—	—	Not Occupied	—	—
37	0.5	BU / YE	4979	AUTOSAR CAN Bus [+] 2 Serial Data	II	—
38	0.5	WH	4978	AUTOSAR CAN Bus [-] 2 Serial Data	II	—
39 - 44	—	—	—	Not Occupied	—	—
45	0.5	GN / YE	10816	Lubricant Circuit Pressure Sensor Signal	II	—
46 - 48	—	—	—	Not Occupied	—	—
49	0.5	GY / BN	6388	Transmission High Side Driver 2 Control	II	—
50 - 52	—	—	—	Not Occupied	—	—
53	0.5	BU / YE	4979	AUTOSAR CAN Bus [+] 2 Serial Data	II	—
54	0.5	WH	4978	AUTOSAR CAN Bus [-] 2 Serial Data	II	—
55 - 58	—	—	—	Not Occupied	—	—
59	0.5	VT / WH	6319	Electronic Transmission Range Select Out of Park Switch 2 Signal	II	—
60	—	—	—	Not Occupied	—	—
61	0.5	WH / YE	6317	Electronic Transmission Range Select Out of Park Switch Signal	II	—
62	0.5	BN	3706	Electronic Transmission Range Select Switch Analog Signal 1	II	—

**6-414 Electrical Component and Inline Harness Connector End Views****K71 Transmission Control Module (cont'd)**

Pin	Size	Color	Circuit	Function	Terminal Type ID	Option
63	0.5	BN / WH	585	Transmission Fluid Temperature Sensor Signal	II	—
64	0.5	BU / WH	3338	Transmission Internal Mode Switch Mode Control X	II	—
65	1.5	BK / WH	251	Signal Ground	I	—
66	1.5	RD / GN	1840	Battery Positive Voltage	I	—

## K73 Telematic Control Module X1

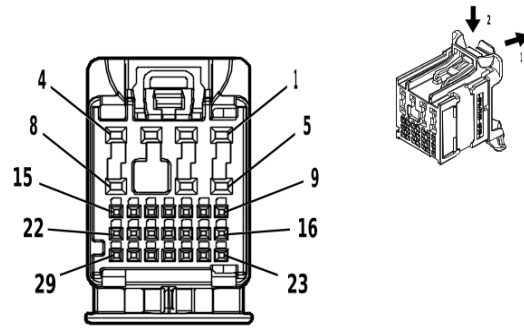

4496253

### Connector Part Information

Harness Type: Instrument Panel Wiring Harness  
 OEM Connector: 160014-0014  
 Service Connector: 13534974  
 Description: 29-Way F 0.5 NANO, 1.2 MCON, stAK50h Series( BK)

### Terminal Part Information

Terminal Type ID	Terminated Lead	Diagnostic Test Probe	Terminal Removal Tool
I	19370262	EL-35616-58 (BK)	EL-38125-58
II	84729890	J-35616-12 (BU)	J-38125-215A
III	Service by Cable	No Tool Required	No Tool Required

### K73 Telematic Control Module X1

Pin	Size	Color	Circuit	Function	Terminal Type ID	Option
1	0.5	RD / YE	3040	Battery Positive Voltage	II	—
2 - 3	—	—	—	Not Occupied	—	—
4	0.75	BK / WH	1051	Signal Ground	II	—
5	—	—	—	Not Occupied	—	—
6	0.35	GN / BK	2515	Telematics Switch Supply Voltage	II	—
7 - 8	—	—	—	Not Occupied	—	—
9	0.35	BU / YE	4984	AUTOSAR CAN Bus [-] 5 Serial Data	I	—
10	0.35	BU / WH	4985	AUTOSAR CAN Bus [+] 5 Serial Data	I	—
11	0.35	GN / WH	2514	Telematics Switch Signal	I	—
12	—	—	—	Not Occupied	—	—
13	0.35	Bare	1792	Low Reference	I	—
14	0.35	BK / GY	5152	Voice Recognition Audio [-] Control	I	—
15	0.35	GY / YE	5149	Voice Recognition Audio Signal	I	—
16	0.35	BU / YE	4984	AUTOSAR CAN Bus [-] 5 Serial Data	I	—
17	0.35	BU / WH	4985	AUTOSAR CAN Bus [+] 5 Serial Data	I	—
18	—	—	—	Not Occupied	—	—
19	0.35	YE / VT	2516	Telematics Switch Green LED Indicator Control	I	—
20	—	—	—	Not Occupied	—	—
21	0.35	BK / BN	654	Cellular Telephone Microphone Low Reference	I	—
22	0.35	BU	655	Cellular Telephone Microphone Signal	I	—

**6-416 Electrical Component and Inline Harness Connector End Views****K73 Telematic Control Module X1 (cont'd)**

Pin	Size	Color	Circuit	Function	Terminal Type ID	Option
23 - 25	—	—	—	Not Occupied	—	—
26	0.35	BN / WH	2517	Telematics Switch Red LED Indicator Control	I	—
27	—	—	—	Not Occupied	—	—
28	0.35	BN	7211	Ethernet Bus 4 [+]	III	—
29	0.35	GY	7210	Ethernet Bus 4 [-]	III	—

**K73 Telematic Control Module X2**

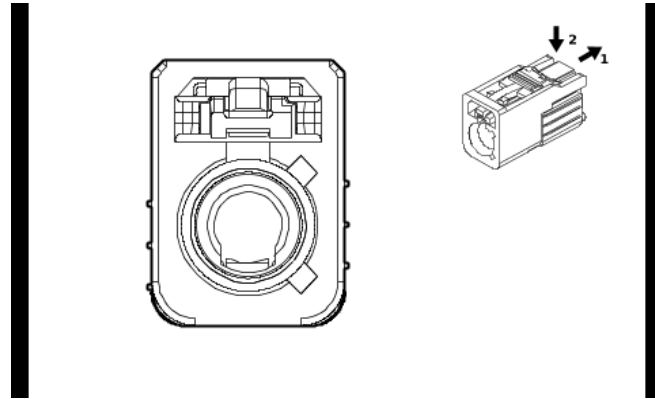

5630760

**Connector Part Information**

Harness Type: Instrument Panel Wiring Harness COAX  
 OEM Connector: 33340312  
 Service Connector: Service by Cable Assembly — See Part Catalog  
 Description: 1-Way F Coax Type( VT)

**Terminal Part Information**

Terminal Type ID	Terminated Lead	Diagnostic Test Probe	Terminal Removal Tool
I	Not required	No Tool Required	No Tool Required

**K73 Telematic Control Module X2**

Pin	Size	Color	Circuit	Function	Terminal Type ID	Option
—	—	Coax Cable	—	(Cell only) Coaxial Antenna Cell Phone Signal	I	—

**K73 Telematic Control Module X3**

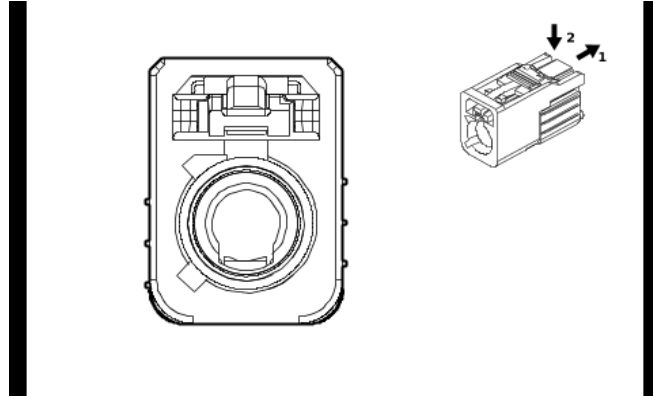

5630785

**Connector Part Information**

Harness Type: Instrument Panel Wiring Harness COAX  
 OEM Connector: 33340314  
 Service Connector: Service by Cable Assembly — See Part Catalog  
 Description: 1-Way F Coax Type( BN)

**Terminal Part Information**

Terminal Type ID	Terminated Lead	Diagnostic Test Probe	Terminal Removal Tool
I	Not required	No Tool Required	No Tool Required

**K73 Telematic Control Module X3**

Pin	Size	Color	Circuit	Function	Terminal Type ID	Option
—	—	Coax Cable	—	(GPS/Cell) Coaxial Antenna Cell/GPS combined Signal	I	—



## K77 Remote Function Actuator Module

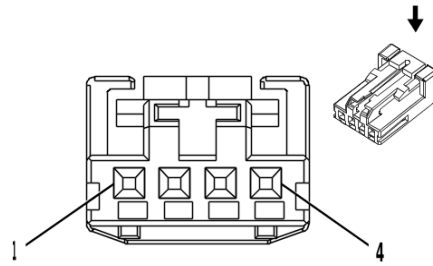

2717162

### Connector Part Information

Harness Type: Body Wiring Harness  
 OEM Connector: 1-936119-1  
 Service Connector: 19367524  
 Description: 4-Way F 0.64 Micro-Quadlock Series( BK)

### Terminal Part Information

Terminal Type ID	Terminated Lead	Diagnostic Test Probe	Terminal Removal Tool
I	Not required	J-35616-64B (L-BU)	No Tool Required

### K77 Remote Function Actuator Module

Pin	Size	Color	Circuit	Function	Terminal Type ID	Option
1	0.5	RD / VT	2640	Battery Positive Voltage	I	—
2	0.35	GN / YE	2862	Body Control Module LIN Bus 16	I	—
3	—	—	—	Not Occupied	—	—
4	0.75	BK / WH	1451	Signal Ground	I	—

**K85P Restraints Occupant Classification System Module - Passenger (AL0)**

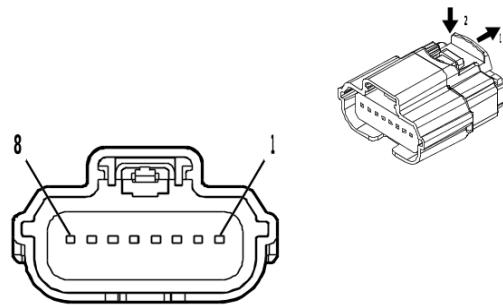

4708234

**Connector Part Information**

Harness Type: Front Seat Wiring Harness - Passenger  
 OEM Connector: 31404-9110  
 Service Connector: Service by Harness - See Part Catalog  
 Description: 8-Way F 64 Series, Sealed( BK)

**Terminal Part Information**

Terminal Type ID	Terminated Lead	Diagnostic Test Probe	Terminal Removal Tool
I	Not required	J-35616-64B (L-BU)	No Tool Required

**K85P Restraints Occupant Classification System Module - Passenger (AL0)**

Pin	Size	Color	Circuit	Function	Terminal Type ID	Option
1	0.5	RD / GN	4440	Battery Positive Voltage	I	—
2	0.5	BU	4987	AUTOSAR CAN Bus [+] 1 Serial Data	I	—
3	0.5	BU	4987	AUTOSAR CAN Bus [+] 1 Serial Data	I	—
4	0.5	WH	4986	AUTOSAR CAN Bus [-] 1 Serial Data	I	—
5	0.5	WH	4986	AUTOSAR CAN Bus [-] 1 Serial Data	I	—
6	0.5	BK / WH	1251	Signal Ground	I	—
7	0.5	OG / BN	3947	Passenger Automatic Locking Retractor Switch Signal	I	—
8	0.5	GY / OG	3946	Passenger Automatic Locking Retractor Switch Low Reference	I	—

## K99 Steering Column Control Module X1 (N38)

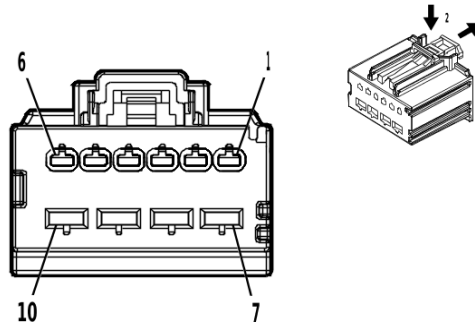

5035058

### Connector Part Information

Harness Type: Instrument Panel Wiring Harness  
 OEM Connector: 31372-1600  
 Service Connector: 13525907  
 Description: 10-Way F 1.5, 2.8 MX Series( BK)

### Terminal Part Information

Terminal Type ID	Terminated Lead	Diagnostic Test Probe	Terminal Removal Tool
I	19300432	J-35616-2A (GY)	J-38125-557
II	85544080	J-35616-4A (PU)	J-38125-11A

### K99 Steering Column Control Module X1 (N38)

Pin	Size	Color	Circuit	Function	Terminal Type ID	Option
1	0.5	VT / BK	2020	Steering Column Tilt and Telescope Switch Feedback Signal	I	—
2	0.5	GN / WH	7530	Driver Seat Adjuster Memory Module LIN Bus 1	I	—
3	0.5	GN / BN	2095	Steering Column Tilt and Telescope Switch Rearward Signal	I	—
4	0.5	BN / GY	2096	Steering Column Tilt and Telescope Switch Up Signal	I	—
5	0.5	YE / BN	2097	Steering Column Tilt and Telescope Switch Down Signal	I	—
6	0.5	BU / YE	2094	Steering Column Tilt and Telescope Switch Forward Signal	I	—
7	0.75	RD / VT	4640	Battery Positive Voltage	II	—
8	1.5	BK	1050	Ground	II	—
9 - 10	—	—	—	Not Occupied	—	—

**K99 Steering Column Control Module X2 (N38)**

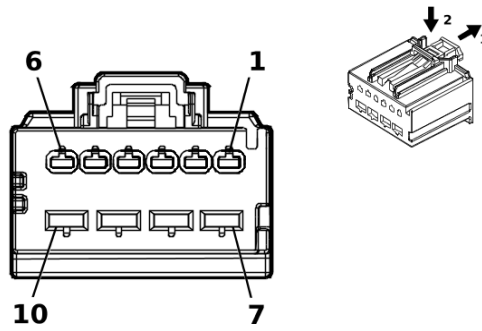

5190551

**Connector Part Information**

Harness Type: Steering Column Tilt and Telescope Wheel Actuator Motor Harness  
 OEM Connector: 31372-1700  
 Service Connector: Service by Harness - See Part Catalog  
 Description: 10-Way F 1.5, 2.8 MX Series( GY)

**Terminal Part Information**

Terminal Type ID	Terminated Lead	Diagnostic Test Probe	Terminal Removal Tool
I	Not required	No Tool Required	No Tool Required

**K99 Steering Column Control Module X2 (N38)**

Pin	Size	Color	Circuit	Function	Terminal Type ID	Option
1	0.35	VT / GY	2153	Steering Column Telescope Motor Signal	I	—
2	0.35	WH	2152	Steering Column Telescope Motor Low Reference	I	—
3	0.35	BN	2154	Steering Column Tilt Motor Signal	I	—
4	0.35	BU	2157	Steering Column Tilt Motor Low Reference	I	—
5 - 6	—	—	—	Not Occupied	—	—
7	1	GN	2098	Steering Column Telescope Motor Forward Control	I	—
8	1	RD	2110	Steering Column Telescope Motor Rearward Control	I	—
9	1	OG	2112	Steering Column Tilt Motor Down Control	I	—
10	1	VT	2111	Steering Column Tilt Motor Up Control	I	—

### K111 Fuel Pump Power Control Module (FJW)

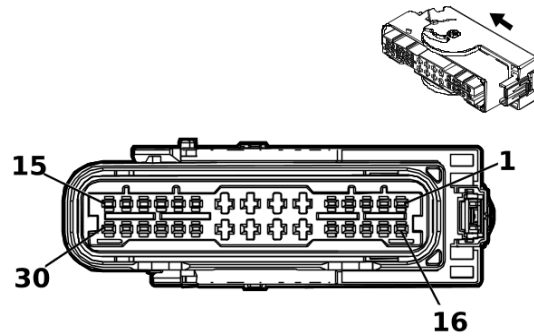

3240109

#### Connector Part Information

Harness Type: Chassis Wiring Harness  
 OEM Connector: 5-2109446-2  
 Service Connector: 86545828  
 Description: 30-Way F 1.5, 2.8 MCP Series, Sealed( BK)

#### Terminal Part Information

Terminal Type ID	Terminated Lead	Diagnostic Test Probe	Terminal Removal Tool
I	19329958	J-35616-2A (GY)	J-38125-11A
II	85533337	J-35616-35 (VT)	J-38125-11A

#### K111 Fuel Pump Power Control Module (FJW)

Pin	Size	Color	Circuit	Function	Terminal Type ID	Option
1	—	—	—	Not Occupied	—	—
2	0.5	BU / YE	6861	Water In Fuel Sensor Signal	I	—
3	0.5	BK / BU	6863	Water In Fuel Sensor Low Reference	I	—
4	0.5	BN / GY	7072	Fuel Temperature Sensor 1 Signal	I	—
5 - 6	—	—	—	Not Occupied	—	—
7	2.5	RD / VT	1940	Battery Positive Voltage	II	—
8	2.5	GY	120	Fuel Pump Control	II	—
9	2.5	YE / GY	4137	Fuel Pump Supply Voltage Phase 2	II	—
10	0.5	YE / RD	2709	Fuel Tank Pressure Sensor 5V Reference	I	—
11	0.5	BU / WH	890	Fuel Tank Pressure Sensor Signal	I	—
12	0.5	BN / RD	7445	Fuel Line Pressure Sensor 5V Reference	I	—
13	0.5	BU / GN	1936	Primary Fuel Level Sensor Signal	I	—
14	—	—	—	Not Occupied	—	—
15	0.5	BU / GY	4054	Private Serial Data Powertrain CAN Bus [-] Serial Data	I	—
16	1 0.5	VT / GN VT / GN	4320 4320	Powertrain Sensor Bus Enable Powertrain Sensor Bus Enable	I I	FHX FJW
17	—	—	—	Not Occupied	—	—
18	0.5	GN / GY	465	Fuel Pump Primary Relay Control	I	—
19	0.5	BN / WH	7073	Fuel Temperature Sensor 1 Low Reference	I	—
20	—	—	—	Not Occupied	—	—

**6-424 Electrical Component and Inline Harness Connector End Views****K111 Fuel Pump Power Control Module (FJW) (cont'd)**

Pin	Size	Color	Circuit	Function	Terminal Type ID	Option
21	0.5	WH	1310	EVAP Vent Solenoid Valve Control	II	—
22	2.5	BK	1650	Ground	II	—
23	0.5	WH	7444	Fuel Pump Assembly Shield Ground	II	—
24	2.5	WH / BN	4138	Fuel Pump Supply Voltage Phase 3	II	—
25	0.5	BK / BN	6284	Fuel Tank Pressure Sensor Low Reference	I	—
26	0.5	BU / WH	7446	Fuel Pressure Sensor Signal	I	—
27	0.5	BK / YE	7447	Fuel Pressure Sensor Low Reference	I	—
28	0.5	BK / GN	6281	Fuel Level Sensor Low Reference	I	—
29	—	—	—	Not Occupied	—	—
30	0.5	WH	4055	Private Serial Data Powertrain CAN Bus [+] Serial Data	I	—

## K111 Fuel Pump Power Control Module - Double Cab / Crew Cab (FHS)

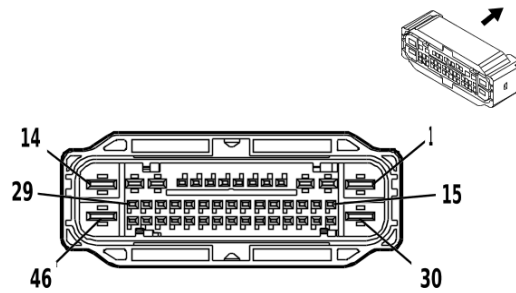

4162046

### Connector Part Information

Harness Type: Chassis Wiring Harness  
 OEM Connector: 33222138  
 Service Connector: 19333026  
 Description: 46-Way F 1.2 OCS, 2.8, 6.3 CTS Series, Sealed( GY)

### Terminal Part Information

Terminal Type ID	Terminated Lead	Diagnostic Test Probe	Terminal Removal Tool
I	13575368	J-35616-35 (VT)	J-38125-36
II	19370818	J-35616-12 (BU)	J-38125-215A
III	84634921	J-35616-42 (RD)	J-38125-212

### K111 Fuel Pump Power Control Module - Double Cab / Crew Cab (FHS)

Pin	Size	Color	Circuit	Function	Terminal Type ID	Option
1	2.5	WH / BN	4138	Fuel Pump Supply Voltage Phase 3	III	—
2	2.5	GY	120	Fuel Pump Control	I	—
3 - 4	—	—	—	Not Occupied	—	—
5	0.5	BK / GY	3802	Fuel Composition Sensor Low Reference	II	—
6	—	—	—	Not Occupied	—	—
7	0.5	WH	4055	Private Serial Data Powertrain CAN Bus [+] Serial Data	II	—
8	0.5	BU / GY	4054	Private Serial Data Powertrain CAN Bus [-] Serial Data	II	—
9	—	—	—	Not Occupied	—	—
10	0.5	VT / GN	4320	Powertrain Sensor Bus Enable	II	—
11	0.5	GN / GY	465	Fuel Pump Primary Relay Control	II	—
12 - 13	—	—	—	Not Occupied	—	—
14	2.5	BK	1650	Ground	III	—
15	0.5	WH	7444	Fuel Pump Assembly Shield Ground	II	—
16	0.5	VT / BN	3803	Fuel Composition Sensor Signal	II	—
17 - 18	—	—	—	Not Occupied	—	—
19	0.5	BN / RD	7445	Fuel Line Pressure Sensor 5V Reference	II	—
20	0.5	BU / WH	7446	Fuel Pressure Sensor Signal	II	—
21	0.5	BK / GN	6281	Fuel Level Sensor Low Reference	II	—
22	—	—	—	Not Occupied	—	—

**6-426 Electrical Component and Inline Harness Connector End Views****K111 Fuel Pump Power Control Module - Double Cab / Crew Cab (FHS) (cont'd)**

Pin	Size	Color	Circuit	Function	Terminal Type ID	Option
23	0.5	BK / BN	6284	Fuel Tank Pressure Sensor Low Reference	II	—
24 - 29	—	—	—	Not Occupied	—	—
30	2.5	YE / GY	4137	Fuel Pump Supply Voltage Phase 2	III	—
31 - 34	—	—	—	Not Occupied	—	—
35	0.5	BK / YE	7447	Fuel Pressure Sensor Low Reference	II	—
36	—	—	—	Not Occupied	—	—
37	0.5	BU / GN	1936	Primary Fuel Level Sensor Signal	II	—
38	—	—	—	Not Occupied	—	—
39	0.5	YE / RD	2709	Fuel Tank Pressure Sensor 5V Reference	II	—
40	0.5	BU / GN	890	Fuel Tank Pressure Sensor Signal	II	—
41 - 42	—	—	—	Not Occupied	—	—
43	0.5	WH	1310	EVAP Vent Solenoid Valve Control	II	—
44 - 45	—	—	—	Not Occupied	—	—
46	2.5	RD / VT	1940	Battery Positive Voltage	III	—



### K111 Fuel Pump Power Control Module - Regular Cab (FHS)

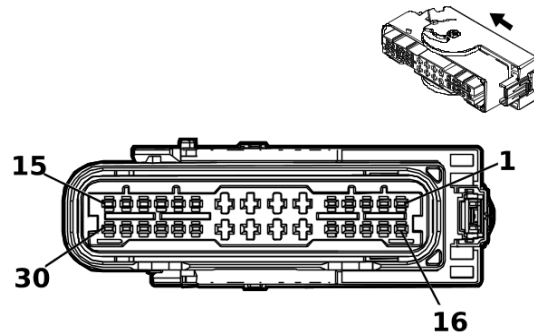

3240109

#### Connector Part Information

Harness Type: Chassis Wiring Harness  
 OEM Connector: 5-2109446-2  
 Service Connector: 86545828  
 Description: 30-Way F 1.5, 2.8 MCP Series, Sealed( BK)

#### Terminal Part Information

Terminal Type ID	Terminated Lead	Diagnostic Test Probe	Terminal Removal Tool
I	19329958	J-35616-2A (GY)	J-38125-11A
II	85533337	J-35616-35 (VT)	J-38125-11A

#### K111 Fuel Pump Power Control Module - Regular Cab (FHS)

Pin	Size	Color	Circuit	Function	Terminal Type ID	Option
1 - 6	—	—	—	Not Occupied	—	—
7	2.5	RD / VT	1940	Battery Positive Voltage	II	—
8	2.5	GY	120	Fuel Pump Control	II	—
9	2.5	YE / GY	4137	Fuel Pump Supply Voltage Phase 2	II	—
10	0.5	YE / RD	2709	Fuel Tank Pressure Sensor 5V Reference	I	—
11	0.5	BU / WH	890	Fuel Tank Pressure Sensor Signal	I	—
12	0.5	BN / RD	7445	Fuel Line Pressure Sensor 5V Reference	I	—
13	0.5	BU / GN	1936	Primary Fuel Level Sensor Signal	I	—
14	—	—	—	Not Occupied	—	—
15	0.5	BU / GY	4054	Private Serial Data Powertrain CAN Bus [-] Serial Data	I	—
16	0.5	VT / GN	4320	Powertrain Sensor Bus Enable	I	—
17	—	—	—	Not Occupied	—	—
18	0.5	GN / GY	465	Fuel Pump Primary Relay Control	I	—
19 - 20	—	—	—	Not Occupied	—	—
21	0.5	WH	1310	EVAP Vent Solenoid Valve Control	II	—
22	2.5	BK	1650	Ground	II	—
23	0.5	WH	7444	Fuel Pump Assembly Shield Ground	II	—
24	2.5	WH / BN	4138	Fuel Pump Supply Voltage Phase 3	II	—
25	0.5	BK / BN	6284	Fuel Tank Pressure Sensor Low Reference	I	—
26	0.5	BU / WH	7446	Fuel Pressure Sensor Signal	I	—

**6-428 Electrical Component and Inline Harness Connector End Views****K111 Fuel Pump Power Control Module - Regular Cab (FHS) (cont'd)**

Pin	Size	Color	Circuit	Function	Terminal Type ID	Option
27	0.5	BK / YE	7447	Fuel Pressure Sensor Low Reference	I	—
28	0.5	BK / GN	6281	Fuel Level Sensor Low Reference	I	—
29	—	—	—	Not Occupied	—	—
30	0.5	WH	4055	Private Serial Data Powertrain CAN Bus [+] Serial Data	I	—

### K111 Fuel Pump Power Control Module - Regular Cab (FJW)

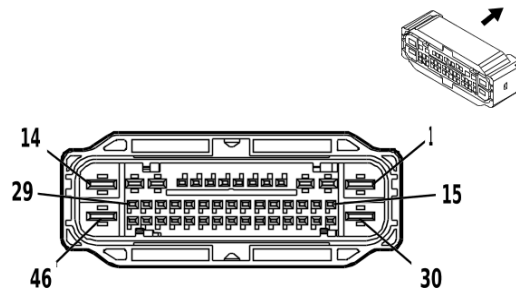

4162046

#### Connector Part Information

Harness Type: Chassis Wiring Harness  
 OEM Connector: 33222138  
 Service Connector: 19333026  
 Description: 46-Way F 1.2 OCS, 2.8, 6.3 CTS Series, Sealed( GY)

#### Terminal Part Information

Terminal Type ID	Terminated Lead	Diagnostic Test Probe	Terminal Removal Tool
I	13575368	J-35616-35 (VT)	J-38125-36
II	19370818	J-35616-12 (BU)	J-38125-215A
III	84634921	J-35616-42 (RD)	J-38125-212

#### K111 Fuel Pump Power Control Module - Regular Cab (FJW)

Pin	Size	Color	Circuit	Function	Terminal Type ID	Option
1	2.5	WH / BN	4138	Fuel Pump Supply Voltage Phase 3	III	—
2	2.5	GY	120	Fuel Pump Control	I	—
3 - 4	—	—	—	Not Occupied	—	—
5	0.5	BK / GY	3802	Fuel Composition Sensor Low Reference	II	—
6	—	—	—	Not Occupied	—	—
7	0.5	WH	4055	Private Serial Data Powertrain CAN Bus [+] Serial Data	II	—
8	0.5	BU / GY	4054	Private Serial Data Powertrain CAN Bus [-] Serial Data	II	—
9	—	—	—	Not Occupied	—	—
10	0.5	VT / GN	4320	Powertrain Sensor Bus Enable	II	—
11	0.5	GN / GY	465	Fuel Pump Primary Relay Control	II	—
12 - 13	—	—	—	Not Occupied	—	—
14	2.5	BK	1650	Ground	III	—
15	0.5	WH	7444	Fuel Pump Assembly Shield Ground	II	—
16	0.5	VT / BN	3803	Fuel Composition Sensor Signal	II	—
17 - 18	—	—	—	Not Occupied	—	—
19	0.5	BN / RD	7445	Fuel Line Pressure Sensor 5V Reference	II	—
20	0.5	BU / WH	7446	Fuel Pressure Sensor Signal	II	—
21	0.5	BK / GN	6281	Fuel Level Sensor Low Reference	II	—
22	—	—	—	Not Occupied	—	—

**6-430 Electrical Component and Inline Harness Connector End Views****K111 Fuel Pump Power Control Module - Regular Cab (FJW) (cont'd)**

Pin	Size	Color	Circuit	Function	Terminal Type ID	Option
23	0.5	BK / BN	6284	Fuel Tank Pressure Sensor Low Reference	II	—
24 - 29	—	—	—	Not Occupied	—	—
30	2.5	YE / GY	4137	Fuel Pump Supply Voltage Phase 2	III	—
31 - 34	—	—	—	Not Occupied	—	—
35	0.5	BK / YE	7447	Fuel Pressure Sensor Low Reference	II	—
36	—	—	—	Not Occupied	—	—
37	0.5	BU / GN	1936	Primary Fuel Level Sensor Signal	II	—
38	—	—	—	Not Occupied	—	—
39	0.5	YE / RD	2709	Fuel Tank Pressure Sensor 5V Reference	II	—
40	0.5	BU / GN	890	Fuel Tank Pressure Sensor Signal	II	—
41 - 42	—	—	—	Not Occupied	—	—
43	0.5	WH	1310	EVAP Vent Solenoid Valve Control	II	—
44 - 45	—	—	—	Not Occupied	—	—
46	2.5	RD / VT	1940	Battery Positive Voltage	III	—

**K115 Reductant Control Module (LZ0)**

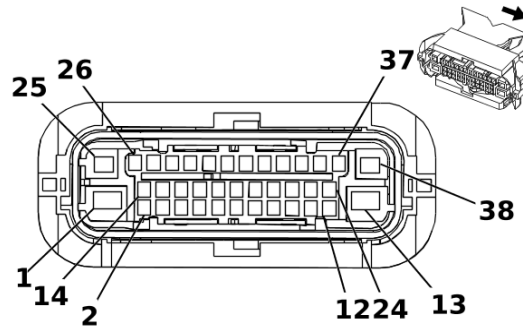

3240110

**Connector Part Information**

Harness Type: Emission Reduction Fluid Tank Reservoir Wire Harness  
 OEM Connector: 13582126  
 Service Connector: Service by Harness - See Part Catalog  
 Description: 38-Way F 1.5 CTS, 2.8 MCP, 4.8 MCP Series, Sealed( BK with BK Inner Connector)

**Terminal Part Information**

Terminal Type ID	Terminated Lead	Diagnostic Test Probe	Terminal Removal Tool
I	Not required	J-35616-14 (GN)	No Tool Required
II	Not required	J-35616-40 (BU)	No Tool Required
III	Not required	J-35616-4A (PU)	No Tool Required

**K115 Reductant Control Module (LZ0)**

Pin	Size	Color	Circuit	Function	Terminal Type ID	Option
1	3	BK	2040	Battery Positive Voltage	II	—
2	1	BN	3676	Diesel Exhaust Fluid Heating Tank 2 Heater Control	I	—
3	—	—	—	Not Occupied	—	—
4	1	YE	3677	Diesel Exhaust Fluid Reservoir Heater Control	I	—
5	—	—	—	Not Occupied	—	—
6	0.5	BK	3244	Diesel Exhaust Fluid Tank Temperature Sensor Signal	I	—
7	0.5	BK	7290	Diesel Exhaust Fluid Sensor Voltage Reference 1	I	—
8	0.5	BN	7284	Diesel Exhaust Fluid Liquid Quality Temperature Signal	I	—
9	0.5	BK	8434	Diesel Exhaust Fluid Sensor Low Reference	I	—
10	—	—	—	Not Occupied	—	—
11	1	YE	3876	Diesel Exhaust Fluid Smart Pump Supply Voltage Phase 3	I	—
12	—	—	—	Not Occupied	—	—
13	3	WH	1650	Ground	II	—
14	1	BN	2936	Diesel Exhaust Fluid Heating Tank 2 Heater Control Low	I	—
15	—	—	—	Not Occupied	—	—
16	1	BU	4318	Diesel Exhaust Fluid Tank Heater Low Control	I	—

**6-432 Electrical Component and Inline Harness Connector End Views**
**K115 Reductant Control Module (LZ0) (cont'd)**

Pin	Size	Color	Circuit	Function	Terminal Type ID	Option
17	—	—	—	Not Occupied	—	—
18	0.5	BN	3245	Diesel Exhaust Fluid Tank Temperature Sensor Low Reference	I	—
19	0.5	BN	3106	Diesel Exhaust Fluid Pressure Sensor 5 Volt Reference	I	—
20	0.5	BU	3108	Diesel Exhaust Fluid Pressure Sensor Signal	I	—
21	0.5	BU	3107	Diesel Exhaust Fluid Pressure Sensor Low Reference	I	—
22 - 23	—	—	—	Not Occupied	—	—
24	1	BN	3875	Diesel Exhaust Fluid Smart Pump Supply Voltage Phase 2	I	—
25	2	BK	1650	Ground	III	—
26	1	WH	3199	Diesel Exhaust Fluid Pressure Line Heater Control	I	—
27	—	—	—	Not Occupied	—	—
28	1	BN	4319	Diesel Exhaust Fluid Line Heater Low Control	I	—
29	—	—	—	Not Occupied	—	—
30	0.5	BN	639	Run/Crank Ignition 1 Voltage	I	—
31	0.5	BU	4977	AUTOSAR CAN Bus [+] 3 Serial Data	I	—
32	0.5	BU	4977	AUTOSAR CAN Bus [+] 3 Serial Data	I	—
33	0.5	BN	4976	AUTOSAR CAN Bus [-] 3 Serial Data	I	—
34	0.5	BN	4976	AUTOSAR CAN Bus [-] 3 Serial Data	I	—
35	—	—	—	Not Occupied	—	—
36	1	BU	2937	Diesel Exhaust Fluid Pump Motor Stator Low Reference	I	—
37	1	WH	3103	Diesel Exhaust Fluid Smart Pump Control	I	—
38	2	RD	3440	Battery Positive Voltage	III	—

**K124 Image Processing Module X1 (UGN - UKL)**

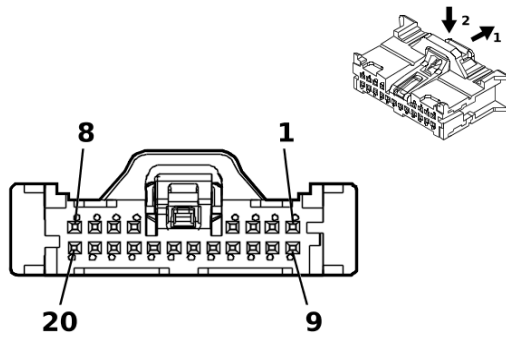

5200955

**Connector Part Information**

Harness Type: Front Floor Console Wiring Harness  
 OEM Connector: 35068196  
 Service Connector: Service by Harness - See Part Catalog  
 Description: 20-Way F Mini 50 Series( BK)

**Terminal Part Information**

Terminal Type ID	Terminated Lead	Diagnostic Test Probe	Terminal Removal Tool
I	Not required	EL-35616-58 (BK)	No Tool Required

**K124 Image Processing Module X1 (UGN - UKL)**

Pin	Size	Color	Circuit	Function	Terminal Type ID	Option
1	0.35	BK / WH	1451	Signal Ground	I	—
2	0.35	RD / WH	4740	Battery Positive Voltage	I	—
3 - 5	—	—	—	Not Occupied	—	—
6	0.35	WH	4986	AUTOSAR CAN Bus [-] 1 Serial Data	I	—
7	0.35	BU	4987	AUTOSAR CAN Bus [+] 1 Serial Data	I	—
8 - 17	—	—	—	Not Occupied	—	—
18	0.35	WH	4986	AUTOSAR CAN Bus [-] 1 Serial Data	I	—
19	0.35	BU	4987	AUTOSAR CAN Bus [+] 1 Serial Data	I	—
20	—	—	—	Not Occupied	—	—

**K124 Image Processing Module X1 (UGN & UKL)**

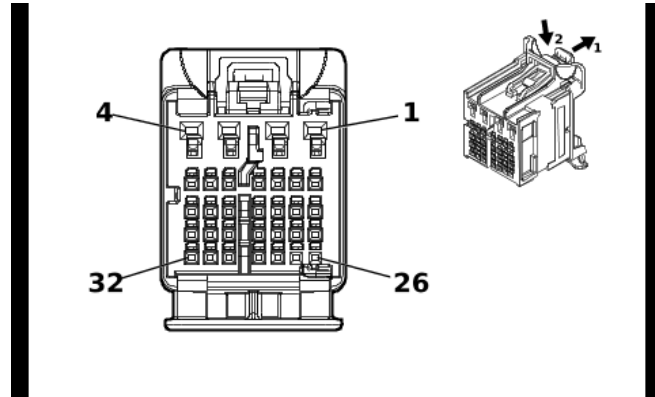

5493608

**Connector Part Information**

Harness Type: Front Floor Console Wiring Harness  
 OEM Connector: 160028-0011  
 Service Connector: Service by Harness - See Part Catalog  
 Description: 32-Way F 0.5 NANO, 1.2 MCON, stAK50h Series( BK with GY Inner Connector)

**Terminal Part Information**

Terminal Type ID	Terminated Lead	Diagnostic Test Probe	Terminal Removal Tool
I	Not required	EL-35616-58 (BK)	No Tool Required
II	Not required	No Tool Required	No Tool Required

**K124 Image Processing Module X1 (UGN & UKL)**

Pin	Size	Color	Circuit	Function	Terminal Type ID	Option
1 - 4	—	—	—	Not Occupied	—	—
5	0.35	RD / WH	4740	Battery Positive Voltage	I	—
6 - 8	—	—	—	Not Occupied	—	—
9	0.35	WH	4986	AUTOSAR CAN Bus [-] 1 Serial Data	I	—
10	0.35	BU	4987	AUTOSAR CAN Bus [+] 1 Serial Data	I	—
11 - 15	—	—	—	Not Occupied	—	—
16	0.35	WH	4986	AUTOSAR CAN Bus [-] 1 Serial Data	I	—
17	0.35	BU	4987	AUTOSAR CAN Bus [+] 1 Serial Data	I	—
18	—	—	—	Not Occupied	—	—
19	0.35	BK / WH	1451	Signal Ground	I	—
20 - 22	—	—	—	Not Occupied	—	—
23	0.35	GN / GY	4627	Image Processing Module LIN Bus 1	I	—
24 - 26	—	—	—	Not Occupied	—	—
27	0.35	VT / GY	8978	Inertial Sensor Supply Voltage	I	—
28 - 30	—	—	—	Not Occupied	—	—
31	0.35	WH	7225	Ethernet Bus 11 [+]	II	—
32	0.35	BU	7224	Ethernet Bus 11 [-]	II	—



**K124 Image Processing Module X2 (UGN - UKL)**

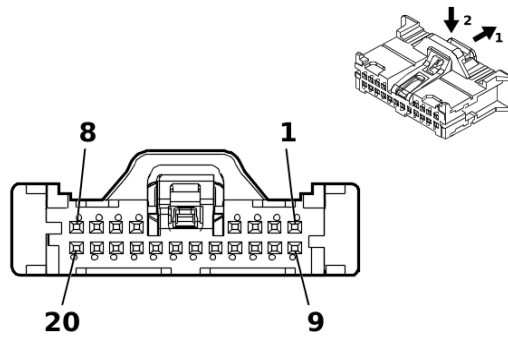

5360760

**Connector Part Information**

Harness Type: Front Floor Console Wiring Harness  
 OEM Connector: 35068197  
 Service Connector: Service by Harness - See Part Catalog  
 Description: 20-Way F 050 CTS Series( GY)

**Terminal Part Information**

Terminal Type ID	Terminated Lead	Diagnostic Test Probe	Terminal Removal Tool
I	Not required	EL-35616-58 (BK)	No Tool Required
II	Not required	No Tool Required	No Tool Required

**K124 Image Processing Module X2 (UGN - UKL)**

Pin	Size	Color	Circuit	Function	Terminal Type ID	Option
1	— 0.35	YE WH	4978	AUTOSAR CAN Bus [-] 2 Serial Data	II	—
			4978	AUTOSAR CAN Bus [-] 2 Serial Data	I	—
2	— 0.35	YE WH	4978	AUTOSAR CAN Bus [-] 2 Serial Data	II	—
			4978	AUTOSAR CAN Bus [-] 2 Serial Data	I	—
3	0.35	BU / YE	4979	AUTOSAR CAN Bus [+] 2 Serial Data	I	—
4	0.35	BU / YE	4979	AUTOSAR CAN Bus [+] 2 Serial Data	I	—
5	— 0.35	WH WH / GY	4978	AUTOSAR CAN Bus [-] 2 Serial Data	II	—
			4104	AUTOSAR CAN Bus [-] 8 Serial Data	I	—
6	—	WH	4978	AUTOSAR CAN Bus [-] 2 Serial Data	II	—
7 - 9	—	—	—	Not Occupied	—	—
10	— 0.35	YE WH	4978	AUTOSAR CAN Bus [-] 2 Serial Data	II	—
			4978	AUTOSAR CAN Bus [-] 2 Serial Data	I	—
11	0.35	BU / YE	4979	AUTOSAR CAN Bus [+] 2 Serial Data	I	—
12	—	—	—	Not Occupied	—	—
13	—	WH	4978	AUTOSAR CAN Bus [-] 2 Serial Data	II	—
14 - 16	—	—	—	Not Occupied	—	—
17	0.35	BU / GY	4105	AUTOSAR CAN Bus [+] 8 Serial Data	I	—
18 - 20	—	—	—	Not Occupied	—	—

**K124 Image Processing Module X2 (UGN & UKL)**

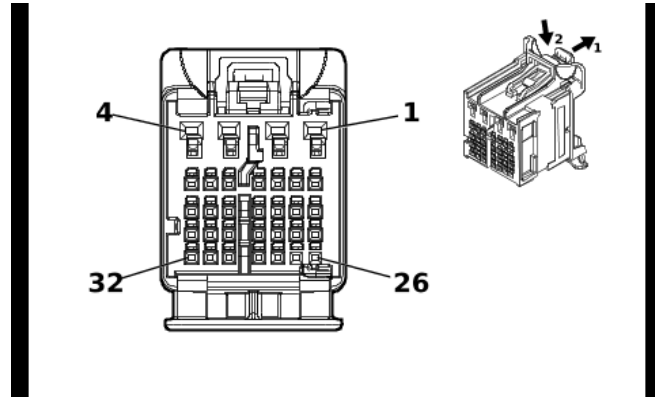

5493614

**Connector Part Information**

Harness Type: Front Floor Console Wiring Harness  
 OEM Connector: 160028-0013  
 Service Connector: Service by Harness - See Part Catalog  
 Description: 32-Way F 0.5 NANO, 1.2 MCON, stAK50h Series( GY with GY Inner Connector)

**Terminal Part Information**

Terminal Type ID	Terminated Lead	Diagnostic Test Probe	Terminal Removal Tool
I	Not required	EL-35616-58 (BK)	No Tool Required

**K124 Image Processing Module X2 (UGN & UKL)**

Pin	Size	Color	Circuit	Function	Terminal Type ID	Option
1 - 4	—	—	—	Not Occupied	—	—
5	0.35	YE	4978	AUTOSAR CAN Bus [-] 2 Serial Data	I	—
6	0.35	YE	4978	AUTOSAR CAN Bus [-] 2 Serial Data	I	—
7	0.35	BU / YE	4979	AUTOSAR CAN Bus [+] 2 Serial Data	I	—
8	0.35	BU / YE	4979	AUTOSAR CAN Bus [+] 2 Serial Data	I	—
9	0.35	WH / GY	4104	AUTOSAR CAN Bus [-] 8 Serial Data	I	—
10	0.35	BU / GY	4105	AUTOSAR CAN Bus [+] 8 Serial Data	I	—
11 - 12	—	—	—	Not Occupied	—	—
13	0.35	YE	4978	AUTOSAR CAN Bus [-] 2 Serial Data	I	—
14	0.35	BU / YE	4979	AUTOSAR CAN Bus [+] 2 Serial Data	I	—
15	0.35	WH / GY	4104	AUTOSAR CAN Bus [-] 8 Serial Data	I	—
16	0.35	WH / GY	4104	AUTOSAR CAN Bus [-] 8 Serial Data	I	—
17	0.35	BU / GY	4105	AUTOSAR CAN Bus [+] 8 Serial Data	I	—
18	0.35	BU / GY	4105	AUTOSAR CAN Bus [+] 8 Serial Data	I	—
19 - 20	—	—	—	Not Occupied	—	—
21	0.35	BU / YE	8977	Private Serial Data Active Safety CAN Bus [+] Serial Data	I	—
22	0.35	WH / YE	8976	Private Serial Data Active Safety CAN Bus [-] Serial Data	I	—
23 - 32	—	—	—	Not Occupied	—	—

## K157 Video Processing Module X1 (UV2)

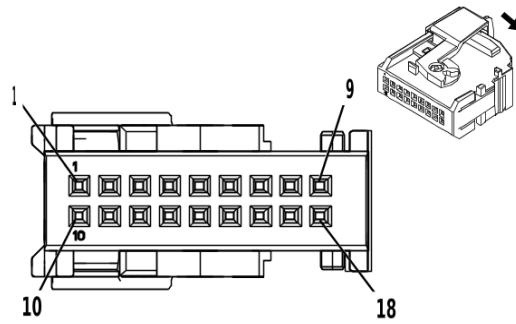

4329088

### Connector Part Information

Harness Type: Body Wiring Harness  
 OEM Connector: 3-2282182-1  
 Service Connector: 84976200  
 Description: 18-Way F Micro-Quadlock Series( BK)

### Terminal Part Information

Terminal Type ID	Terminated Lead	Diagnostic Test Probe	Terminal Removal Tool
I	19300632	J-35616-64B (L-BU)	J-38125-215A

### K157 Video Processing Module X1 (UV2)

Pin	Size	Color	Circuit	Function	Terminal Type ID	Option
1 - 2	—	—	—	Not Occupied	—	—
3	0.75	BK / WH	1451	Signal Ground	I	—
4 - 9	—	—	—	Not Occupied	—	—
10	0.5	RD / VT	1640	Battery Positive Voltage	I	—
11 - 12	—	—	—	Not Occupied	—	—
13	0.5	WH	4986	AUTOSAR CAN Bus [-] 1 Serial Data	I	—
14	0.5	WH	4986	AUTOSAR CAN Bus [-] 1 Serial Data	I	—
15	0.5	BU	4987	AUTOSAR CAN Bus [+] 1 Serial Data	I	—
16	0.5	BU	4987	AUTOSAR CAN Bus [+] 1 Serial Data	I	—
17 - 18	—	—	—	Not Occupied	—	—

**K157 Video Processing Module X3**

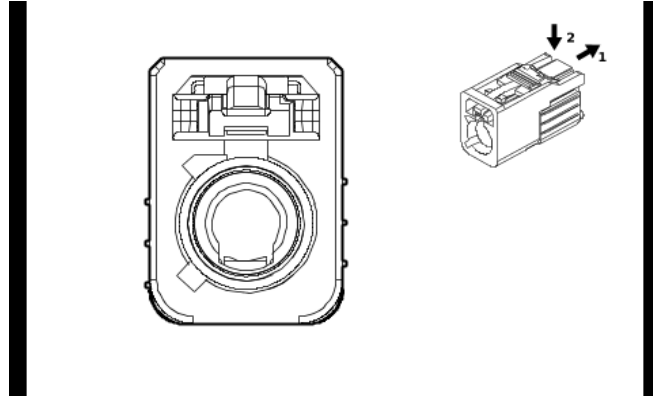

5630785

**Connector Part Information**

Harness Type: Body Wiring Harness COAX  
 OEM Connector: 33340314  
 Service Connector: Service by Cable Assembly — See Part Catalog  
 Description: 1-Way F Coax Type( BN)

**Terminal Part Information**

Terminal Type ID	Terminated Lead	Diagnostic Test Probe	Terminal Removal Tool
I	Not required	No Tool Required	No Tool Required

**K157 Video Processing Module X3**

Pin	Size	Color	Circuit	Function	Terminal Type ID	Option
—	—	Coax Cable	—	Video Processing Module Coaxial Video Signal	I	—

**K157 Video Processing Module X4**

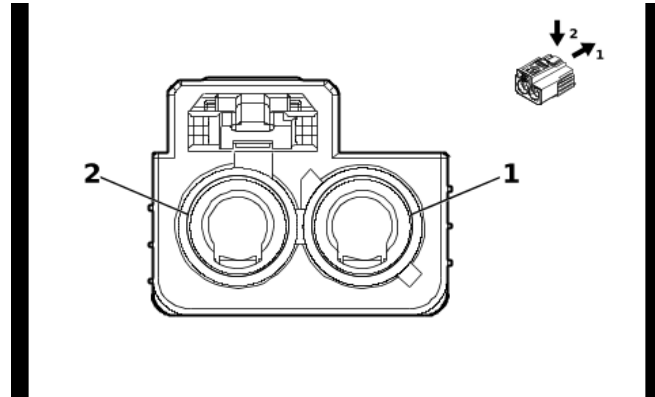

5810836

**Connector Part Information**

Harness Type: Body Wiring Harness  
 OEM Connector: 33340386  
 Service Connector: Service by Cable Assembly — See Part Catalog  
 Description: 2-Way F Coax Type( BG)

**Terminal Part Information**

Terminal Type ID	Terminated Lead	Diagnostic Test Probe	Terminal Removal Tool
I	Not required	No Tool Required	No Tool Required

**K157 Video Processing Module X4**

Pin	Size	Color	Circuit	Function	Terminal Type ID	Option
1	—	—	—	Not Occupied	—	—
2	0	—	2548	Cargo Bed Rear Vision Camera LVDS (Low Voltage Differential Signaling) Coaxial Signal	I	—

**K157 Video Processing Module X5**

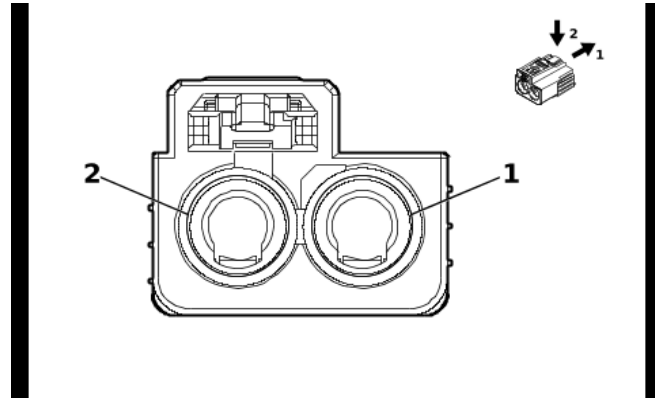

5810827

**Connector Part Information**

Harness Type: Body Wiring Harness  
 OEM Connector: 33340382  
 Service Connector: Service by Cable Assembly — See Part Catalog  
 Description: 2-Way F Coax Type( GN)

**Terminal Part Information**

Terminal Type ID	Terminated Lead	Diagnostic Test Probe	Terminal Removal Tool
I	Not required	No Tool Required	No Tool Required

**K157 Video Processing Module X5**

Pin	Size	Color	Circuit	Function	Terminal Type ID	Option
1	0	—	7886	Trailer 2 Rear Vision Camera LVDS (Low Voltage Differential Signaling) Coaxial Signal	I	—
2	0	—	2421	Trailer Rear Vision Camera LVDS (Low Voltage Differential Signaling) Coaxial Signal	I	—

**K157 Video Processing Module X6**

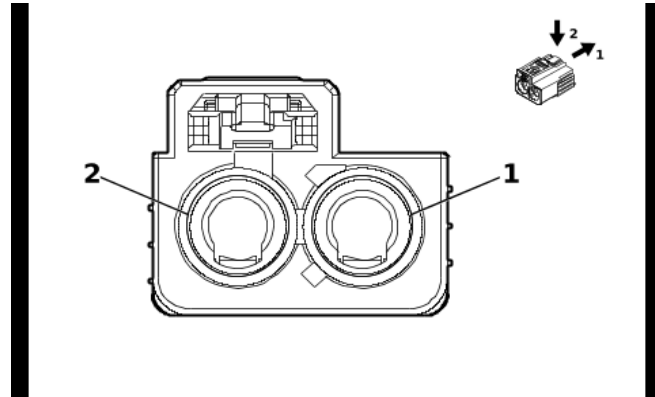

5810832

**Connector Part Information**

Harness Type: Body Wiring Harness  
 OEM Connector: 33340383  
 Service Connector: Service by Cable Assembly — See Part Catalog  
 Description: 2-Way F Coax Type( BN)

**Terminal Part Information**

Terminal Type ID	Terminated Lead	Diagnostic Test Probe	Terminal Removal Tool
I	Not required	No Tool Required	No Tool Required

**K157 Video Processing Module X6**

Pin	Size	Color	Circuit	Function	Terminal Type ID	Option
1	0	—	4724	Right Sideview Camera LVDS (Low Voltage Differential Signaling) Coaxial Signal	I	—
2	0	—	4725	Left Sideview Camera LVDS (Low Voltage Differential Signaling) Coaxial Signal	I	—

**K157 Video Processing Module X7**

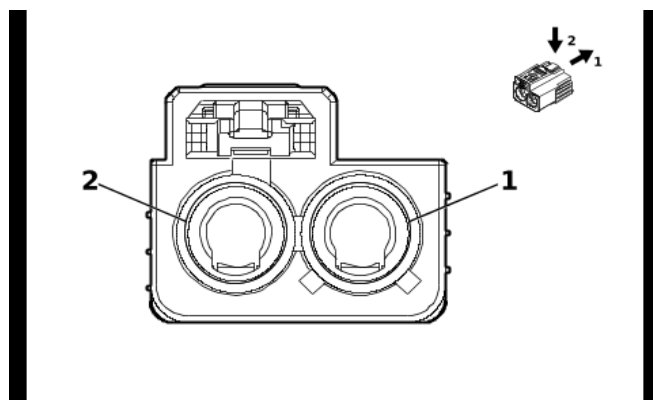

5810835

**Connector Part Information**

Harness Type: Body Wiring Harness  
 OEM Connector: 33340387  
 Service Connector: Service by Cable Assembly — See Part Catalog  
 Description: 2-Way F Coax Type( CU)

**Terminal Part Information**

Terminal Type ID	Terminated Lead	Diagnostic Test Probe	Terminal Removal Tool
I	Not required	No Tool Required	No Tool Required

**K157 Video Processing Module X7**

Pin	Size	Color	Circuit	Function	Terminal Type ID	Option
1	0	—	4722	Frontview Camera LVDS (Low Voltage Differential Signaling) Coaxial Signal	I	—
2	0	—	4721	Rearview Camera LVDS (Low Voltage Differential Signaling) Coaxial Signal	I	—



## K160 Brake System Control Module

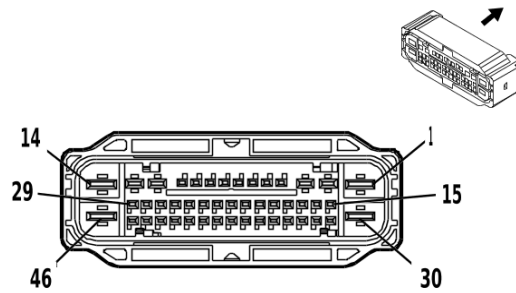

4162046

### Connector Part Information

Harness Type: Body Wiring Harness  
 OEM Connector: 35495608  
 Service Connector: 19333026  
 Description: 46-Way F 1.2 OCS, 2.8, 6.3 CTS Series, Sealed( GY)

### Terminal Part Information

Terminal Type ID	Terminated Lead	Diagnostic Test Probe	Terminal Removal Tool
I	13575368	J-35616-35 (VT)	J-38125-36
II	19370818	J-35616-12 (BU)	J-38125-215A
III	84634921	J-35616-42 (RD)	J-38125-212

### K160 Brake System Control Module

Pin	Size	Color	Circuit	Function	Terminal Type ID	Option
1	6	BK	150	Ground	III	—
2	2.5	WH	2001	Left Park Brake Motor Apply Control	I	—
3	2.5	GY / BK	4369	Left Park Brake Motor Low Reference	I	—
4	0.5	GY / WH	7064	Left Front Wheel Speed Sensor Control	II	—
5	0.5	GY	830	Left Front Wheel Speed Sensor Signal	II	—
6 - 8	—	—	—	Not Occupied	—	—
9	0.5	VT / WH	239	Run/Crank Ignition 1 Voltage	II	—
10	0.5	GY / BN	7065	Right Front Wheel Speed Sensor Control	II	—
11	0.5	YE	872	Right Front Wheel Speed Sensor Signal	II	—
12	2.5	GN / VT	1988	Right Park Brake Motor Apply Control	I	—
13	2.5	GY	4368	Right Park Brake Motor Low Reference	I	—
14	6	RD / WH	1642	Battery Positive Voltage	III	—
15	0.5	GY / BK	7127	Left Rear Wheel Speed Sensor Control	II	—
16	0.5	BU	884	Left Rear Wheel Speed Sensor Signal	II	—
17	0.35	BU / YE	4979	AUTOSAR CAN Bus [+] 2 Serial Data	II	—
18	0.5	BU / YE	4979	AUTOSAR CAN Bus [+] 2 Serial Data	II	—
19	0.35	GN / GY	817	Vehicle Speed Signal	II	—
20 - 22	—	—	—	Not Occupied	—	—
23	0.5	GN / YE	2731	Brake System Control Module LIN Bus 1	II	—
24	—	—	—	Not Occupied	—	—

## 6-444 Electrical Component and Inline Harness Connector End Views

### K160 Brake System Control Module (cont'd)

Pin	Size	Color	Circuit	Function	Terminal Type ID	Option
25	0.5	WH	4986	AUTOSAR CAN Bus [-] 1 Serial Data	II	—
26	0.5	WH	4986	AUTOSAR CAN Bus [-] 1 Serial Data	II	—
27	—	—	—	Not Occupied	—	—
28	0.5	GY / YE	7128	Right Rear Wheel Speed Sensor Control	II	—
29	0.5	VT	882	Right Rear Wheel Speed Sensor Signal	II	—
30	6	BK	250	Ground	III	—
31 - 32	—	—	—	Not Occupied	—	—
33	0.35	WH	4978	AUTOSAR CAN Bus [-] 2 Serial Data	II	—
34	0.5	WH	4978	AUTOSAR CAN Bus [-] 2 Serial Data	II	—
35	0.5	GN / BU	2733	Brake System Control Module LIN Bus 2	II	—
36	0.5	WH / BK	2223	Trailer Brake Apply Signal	II	—
37	0.5	YE / BK	2224	Trailer Brake Enable Signal	II	—
38	0.5	GN / GY	333	Brake Fluid Level Signal	II	—
39	0.5	BN / BU	1602	Front Brake Pad Wear Sensor Signal	II	—
40	—	—	—	Not Occupied	—	—
41	0.5	BU	4987	AUTOSAR CAN Bus [+] 1 Serial Data	II	—
42	0.5	BU	4987	AUTOSAR CAN Bus [+] 1 Serial Data	II	—
43	—	—	—	Not Occupied	—	—
44	0.5	GN / YE	1616	Rear Brake Pad Wear Sensor Signal	II	—
45	—	—	—	Not Occupied	—	—
46	6	RD / WH	1040	Battery Positive Voltage	III	—

## K179 Automated Driving Mapping Module X1 (UKL)

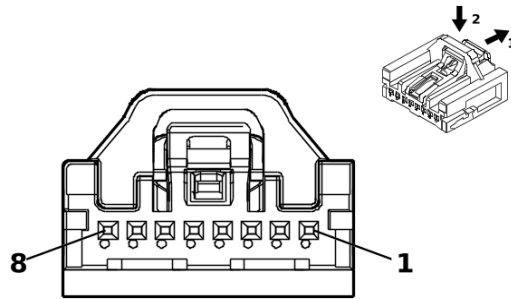

5200269

### Connector Part Information

Harness Type: Instrument Panel Wiring Harness  
 OEM Connector: 35068228  
 Service Connector: 84769201  
 Description: 8-Way F Mini 50 Series( BK)

### Terminal Part Information

Terminal Type ID	Terminated Lead	Diagnostic Test Probe	Terminal Removal Tool
I	Not required	EL-35616-58 (BK)	No Tool Required

### K179 Automated Driving Mapping Module X1 (UKL)

Pin	Size	Color	Circuit	Function	Terminal Type ID	Option
1	0.35	RD / WH	1340	Battery Positive Voltage	I	—
2	0.35	BU / GY	4105	AUTOSAR CAN Bus [+] 8 Serial Data	I	—
3	0.35	WH / GY	4104	AUTOSAR CAN Bus [-] 8 Serial Data	I	—
4	0.35	BU / GY	4105	AUTOSAR CAN Bus [+] 8 Serial Data	I	—
5	0.35	WH / GY	4104	AUTOSAR CAN Bus [-] 8 Serial Data	I	—
6 - 7	—	—	—	Not Occupied	—	—
8	0.35	BK / WH	851	Signal Ground	I	—

**K179 Automated Driving Mapping Module X2 (UKL)**

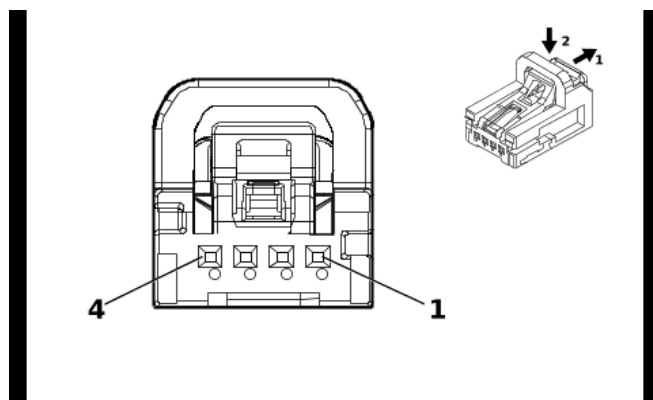

5921812

**Connector Part Information**

Harness Type: Instrument Panel Wiring Harness  
 OEM Connector: 35068221  
 Service Connector: 86825465  
 Description: 4-Way F Mini 50 Series( GN)

**Terminal Part Information**

Terminal Type ID	Terminated Lead	Diagnostic Test Probe	Terminal Removal Tool
I	Service by Cable	No Tool Required	No Tool Required

**K179 Automated Driving Mapping Module X2 (UKL)**

Pin	Size	Color	Circuit	Function	Terminal Type ID	Option
1	—	—	—	Not Occupied	—	—
2	0.35	BU	7208	Ethernet Bus 3 [-]	I	—
3	0.35	GN	7209	Ethernet Bus 3 [+]	I	—
4	—	—	—	Not Occupied	—	—

**K179 Automated Driving Mapping Module X3 (UKL)**

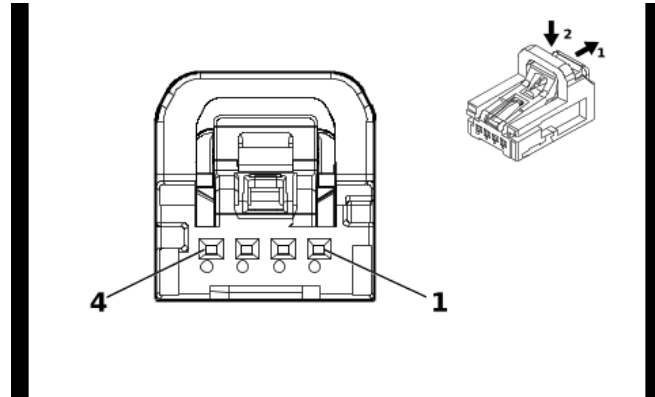

5921811

**Connector Part Information**

Harness Type: Instrument Panel Wiring Harness  
 OEM Connector: 35068220  
 Service Connector: 86825464  
 Description: 4-Way F Mini 50 Series( BN)

**Terminal Part Information**

Terminal Type ID	Terminated Lead	Diagnostic Test Probe	Terminal Removal Tool
I	Service by Cable	No Tool Required	No Tool Required

**K179 Automated Driving Mapping Module X3 (UKL)**

Pin	Size	Color	Circuit	Function	Terminal Type ID	Option
1	—	—	—	Not Occupied	—	—
2	0.35	BU	7224	Ethernet Bus 11 [-]	I	—
3	0.35	WH	7225	Ethernet Bus 11 [+]	I	—
4	—	—	—	Not Occupied	—	—

**K180 Driver Monitoring System Module X1 (UKL)**

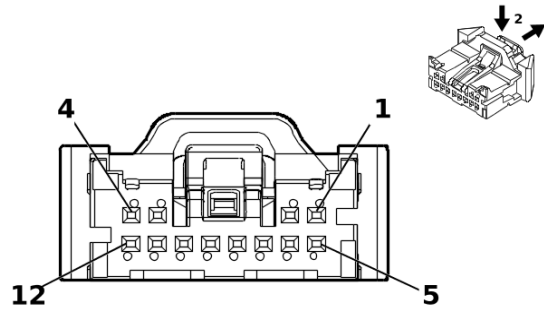

5360826

**Connector Part Information**

Harness Type: Instrument Panel Wiring Harness  
 OEM Connector: 35068239  
 Service Connector: 13529935  
 Description: 12-Way F 050 CTS Series( BK)

**Terminal Part Information**

Terminal Type ID	Terminated Lead	Diagnostic Test Probe	Terminal Removal Tool
I	84944580	EL-35616-58 (BK)	EL-38125-58

**K180 Driver Monitoring System Module X1 (UKL)**

Pin	Size	Color	Circuit	Function	Terminal Type ID	Option
1	0.35	RD / YE	3040	Battery Positive Voltage	I	—
2	0.35	BK / WH	851	Signal Ground	I	—
3	0.35	BU / YE	4979	AUTOSAR CAN Bus [+] 2 Serial Data	I	—
4	0.35	WH	4978	AUTOSAR CAN Bus [-] 2 Serial Data	I	—
5 - 6	—	—	—	Not Occupied	—	—
7	0.35	BU / BN	7744	Driver Illumination Lamp Ground	I	—
8	0.35	YE / BU	2245	Driver Illumination Lamp 2 Control	I	—
9	0.35	WH / VT	2246	Driver Illumination Lamp 1 Control	I	—
10	—	—	—	Not Occupied	—	—
11	0.35	BU / GN	4979	AUTOSAR CAN Bus [+] 2 Serial Data	I	—
12	0.35	WH / BN	4978	AUTOSAR CAN Bus [-] 2 Serial Data	I	—

**K180 Driver Monitoring System Module X2 (UKL)**

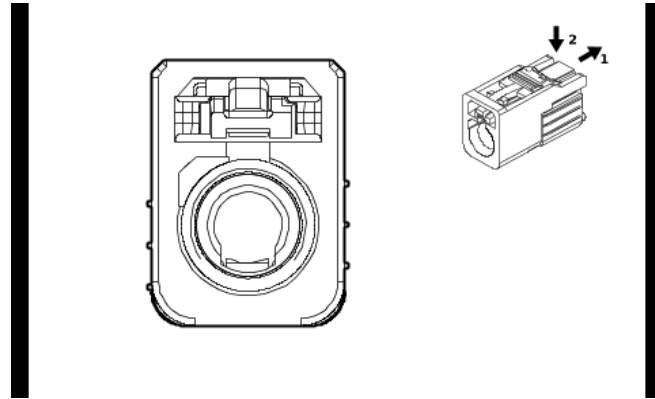

5519144

**Connector Part Information**

Harness Type: Instrument Panel Wiring Harness COAX  
 OEM Connector: 33340313  
 Service Connector: Service by Cable Assembly — See Part Catalog  
 Description: 1-Way F Coax Type( GN)

**Terminal Part Information**

Terminal Type ID	Terminated Lead	Diagnostic Test Probe	Terminal Removal Tool
I	Not required	No Tool Required	No Tool Required

**K180 Driver Monitoring System Module X2 (UKL)**

Pin	Size	Color	Circuit	Function	Terminal Type ID	Option
—	—	Coax Cable	—	Driver Monitoring System Camera Coaxial Signal	I	—

**K182 Parking Assist Control Module X1 (UD5 / UD7)**

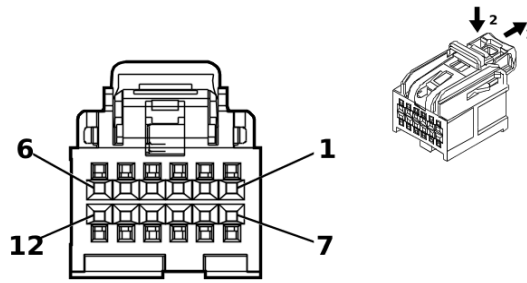

4975223

**Connector Part Information**

Harness Type: Body Wiring Harness  
 OEM Connector: 35016616  
 Service Connector: 13519750  
 Description: 12-Way F 0.64 OCS Series( BK)

**Terminal Part Information**

Terminal Type ID	Terminated Lead	Diagnostic Test Probe	Terminal Removal Tool
I	19300660	J-35616-64B (L-BU)	J-38125-215A

**K182 Parking Assist Control Module X1 (UD5 / UD7)**

Pin	Size	Color	Circuit	Function	Terminal Type ID	Option
1	0.5	RD / WH	4740	Battery Positive Voltage	I	—
2	0.5	WH	4986	AUTOSAR CAN Bus [-] 1 Serial Data	I	—
3	0.5	BU	4987	AUTOSAR CAN Bus [+] 1 Serial Data	I	—
4 - 5	—	—	—	Not Occupied	—	—
6	0.5	BK / WH	1551	Signal Ground	I	EXTENDED CAB/ CREW CAB
	0.75	BK / WH	1551	Signal Ground	I	REGULAR CAB
7	—	—	—	Not Occupied	—	—
8	0.5	WH	4986	AUTOSAR CAN Bus [-] 1 Serial Data	I	—
9	0.5	BU	4987	AUTOSAR CAN Bus [+] 1 Serial Data	I	—
10 - 12	—	—	—	Not Occupied	—	—



**K182 Parking Assist Control Module X2 (UD5 / UD7)**

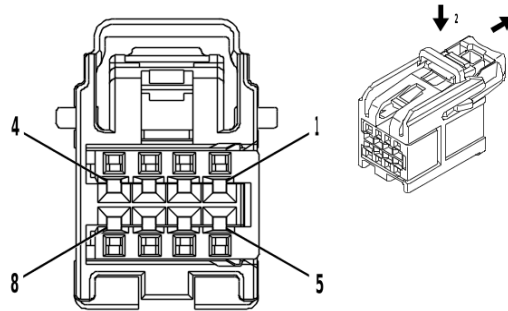

4232228

**Connector Part Information**

Harness Type: Body Wiring Harness  
 OEM Connector: 15526973  
 Service Connector: 19353873  
 Description: 8-Way F 0.64 OCS Series( GY)

**Terminal Part Information**

Terminal Type ID	Terminated Lead	Diagnostic Test Probe	Terminal Removal Tool
I	Not required	J-35616-64B (L-BU)	No Tool Required

**K182 Parking Assist Control Module X2 (UD5 / UD7)**

Pin	Size	Color	Circuit	Function	Terminal Type ID	Option
1	—	—	—	Not Occupied	—	—
2	0.5	YE / WH	2377	Right Rear Middle Parking Assist Sensor Signal	I	—
3	0.5	YE	2375	Left Rear Outer Parking Assist Sensor Signal	I	—
4	0.5	BN / WH	2374	Object Sensor Voltage Reference	I	—
5	0.5	YE / VT	2378	Right Rear Outer Parking Assist Sensor Signal	I	—
6	0.5	YE / BU	2376	Left Rear Middle Parking Assist Sensor Signal	I	—
7	—	—	—	Not Occupied	—	—
8	0.5	BK / GY	2379	Object Sensor Low Reference	I	—

**K182 Parking Assist Control Module X3 (UD5 / UD7)**

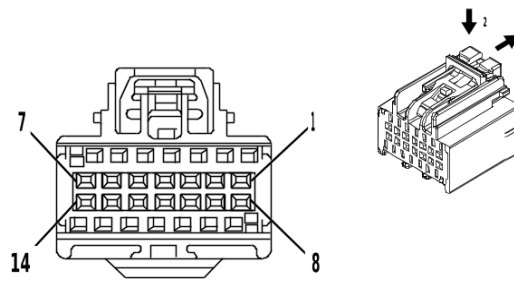

4547098

**Connector Part Information**

Harness Type: Body Wiring Harness  
 OEM Connector: 7289-2897-90  
 Service Connector: 19354933  
 Description: 14-Way F 0.64 Kaizen Series( BU)

**Terminal Part Information**

Terminal Type ID	Terminated Lead	Diagnostic Test Probe	Terminal Removal Tool
I	19303553	J-35616-64B (L-BU)	J-38125-215A

**K182 Parking Assist Control Module X3 (UD5 / UD7)**

Pin	Size	Color	Circuit	Function	Terminal Type ID	Option
1 - 4	—	—	—	Not Occupied	—	—
5	0.5	YE / GY	5216	Left Front Middle Parking Assist Sensor	I	—
6	0.5	WH / GY	5217	Right Front Outer Parking Assist Sensor	I	—
7	0.5	BN	6581	Front Parking Assist Display Control	I	—
8 - 10	—	—	—	Not Occupied	—	—
11	0.5	VT / WH	5215	Left Front Outer Parking Assist Sensor	I	—
12	0.5	VT / GY	5218	Right Front Middle Parking Assist Sensor	I	—
13	—	—	—	Not Occupied	—	—
14	0.5	BK / BU	5214	Front Parking Assist Sensor Low Reference	I	—

**K194 Rear Gate Module**

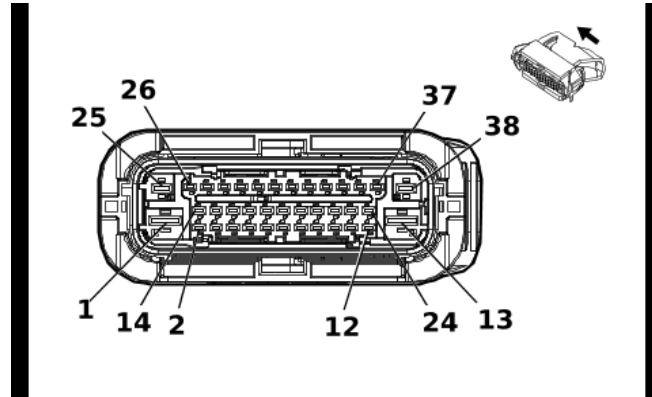

3240112

**Connector Part Information**

Harness Type: Endgate Wiring Harness

OEM Connector: 35503407

Service Connector: Service by Harness - See Part Catalog

Description: 38-Way F 1.5 CTS, 2.8 MCP, 4.8 MCP Series, Sealed( BK with BU Inner Connector)

**Terminal Part Information**

Terminal Type ID	Terminated Lead	Diagnostic Test Probe	Terminal Removal Tool
I	Not required	J-35616-14 (GN)	No Tool Required
II	Not required	J-35616-35 (VT)	No Tool Required
III	Not required	J-35616-40 (BU)	No Tool Required

**K194 Rear Gate Module**

Pin	Size	Color	Circuit	Function	Terminal Type ID	Option
1	2.5	BK	1850	Ground	III	—
2	0.5	WH	4100	AUTOSAR CAN Bus [-] 4 Serial Data	I	—
3	0.5	WH	4100	AUTOSAR CAN Bus [-] 4 Serial Data	I	—
4	—	—	—	Not Occupied	—	—
5	0.5	YE / BK	8085	Rear Closure Latch Primary Status	I	—
6	0.5	BN / GY	10281	Rear Closure Latch Secondary Status Signal	I	—
7	0.5	WH / GN	8084	Rear Closure Latch Neutral Status	I	—
8	0.5	GY / VT	4678	Rear Closure Latch Unlatch Status	I	—
9 - 12	—	—	—	Not Occupied	—	—
13	2.5	RD / VT	4442	Primary Fused Battery Positive Voltage	III	—
14	0.5	BU / VT	4101	AUTOSAR CAN Bus [+] 4 Serial Data	I	—
15	0.5	BU / VT	4101	AUTOSAR CAN Bus [+] 4 Serial Data	I	—
16	0.5	BN	7736	Rear Closure Latch 2 Unlatch Status Signal	I	—
17	—	—	—	Not Occupied	—	—
18	0.5	BN / RD	4683	Rear Closure Position Sensor Voltage Reference	I	—
19	0.5	BK / GN	4687	Rear Closure Position Sensor Low Reference	I	—
20	—	—	—	Not Occupied	—	—
21	0.5	BN / YE	4686	Rear Closure Position Sensor Signal 2	I	—
22	0.5	BU / WH	4685	Rear Closure Position Sensor Signal 1	I	—

**6-454 Electrical Component and Inline Harness Connector End Views****K194 Rear Gate Module (cont'd)**

Pin	Size	Color	Circuit	Function	Terminal Type ID	Option
23	0.5	GN / BU	10283	Rear Closure Latch 2 Primary Status Signal	I	—
24	0.5	VT / WH	10284	Rear Closure Latch 2 Secondary Status Signal	I	—
25	1	BN / WH	4690	Rear Closure Open/Close Motor Close Control	II	—
26	0.5	BU / BN	10282	Rear Closure Latch 2 Neutral Status Signal	I	—
27	0.5	GY / BK	1575	Rear Closure Sensor Low Reference 2	I	—
28	0.5	BK / VT	4656	Rear Closure Object Sensor Low Reference	I	—
29	—	—	—	Not Occupied	—	—
30	1	BU	1509	Rear Closure Cinch Latch Motor 2 Release Control	I	—
31	1	GN	1499	Rear Closure Cinch Latch Motor 2 Cinch Control	I	—
32	—	—	—	Not Occupied	—	—
33	1	BU / GY	4682	Rear Closure Cinch Latch Motor Release Control	I	—
34	1	BN	4681	Rear Closure Cinch Latch Motor Cinch Control	I	—
35	0.5	GN	1577	Rear Closure Clutch Control	I	—
36	0.5	BU / BK	1590	Rear Closure Clutch Low Return	I	—
37	—	—	—	Not Occupied	—	—
38	1	WH	4689	Rear Closure Open/Close Motor Open Control	II	—

## K212 Gear Shift Control Module

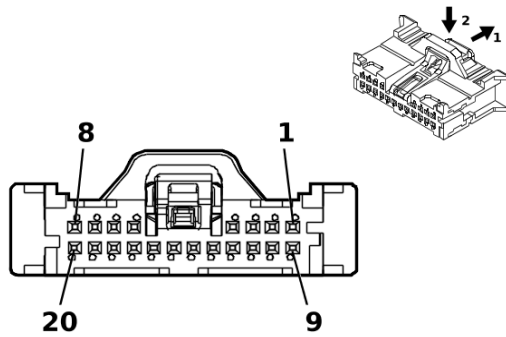

5200955

### Connector Part Information

Harness Type: Front Floor Console Wiring Harness  
 OEM Connector: 35068196  
 Service Connector: Service by Harness - See Part Catalog  
 Description: 20-Way F Mini 50 Series( BK)

### Terminal Part Information

Terminal Type ID	Terminated Lead	Diagnostic Test Probe	Terminal Removal Tool
I	Not required	EL-35616-58 (BK)	No Tool Required

### K212 Gear Shift Control Module

Pin	Size	Color	Circuit	Function	Terminal Type ID	Option
1	0.35	BU / BK	4977	AUTOSAR CAN Bus [+] 3 Serial Data	I	—
2	0.35	BU / BK	4977	AUTOSAR CAN Bus [+] 3 Serial Data	I	—
3	0.35	YE	4976	AUTOSAR CAN Bus [-] 3 Serial Data	I	—
4	0.35	YE	4976	AUTOSAR CAN Bus [-] 3 Serial Data	I	—
5	0.35	WH	4055	Private Serial Data Powertrain CAN Bus [+] Serial Data	I	—
6	0.35	WH	4055	Private Serial Data Powertrain CAN Bus [+] Serial Data	I	—
7	0.35	BU / GY	4054	Private Serial Data Powertrain CAN Bus [-] Serial Data	I	—
8	0.35	BU / GY	4054	Private Serial Data Powertrain CAN Bus [-] Serial Data	I	—
9	0.35	RD / WH	5440	Battery Positive Voltage	I	—
10 - 15	—	—	—	Not Occupied	—	—
16	0.35	VT / GN	4320	Powertrain Sensor Bus Enable	I	—
17	0.35	VT / WH	239	Run/Crank Ignition 1 Voltage	I	—
18 - 19	—	—	—	Not Occupied	—	—
20	0.35	BK	1350	Ground	I	—

**K214 Trailer Tire Pressure Indicator Module (UET)**

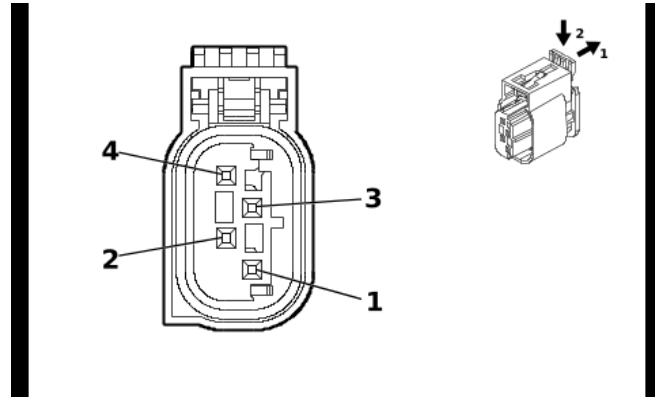

5215490

**Connector Part Information**

Harness Type: Chassis Wiring Harness  
 OEM Connector: 13655424  
 Service Connector: 86825461  
 Description: 4-Way F 0.64 MTS Series, Sealed( BK)

**Terminal Part Information**

Terminal Type ID	Terminated Lead	Diagnostic Test Probe	Terminal Removal Tool
I	Not required	J-35616-64B (L-BU)	No Tool Required

**K214 Trailer Tire Pressure Indicator Module (UET)**

Pin	Size	Color	Circuit	Function	Terminal Type ID	Option
1	0.5	RD / GN	6940	Battery Positive Voltage	I	—
2	0.5	BK / WH	1951	Signal Ground	I	—
3	0.5	GN / YE	2862	Body Control Module LIN Bus 16	I	—
4	—	—	—	Not Occupied	—	—

## K219 Lighting Control Module X1

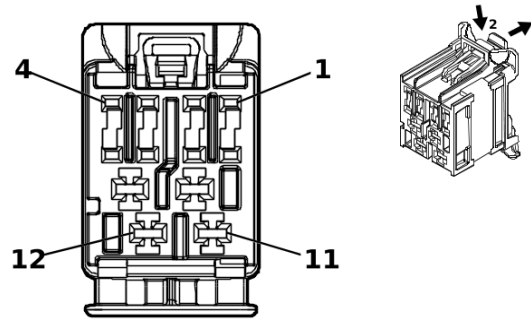

5203784

### Connector Part Information

Harness Type: Body Wiring Harness  
 OEM Connector: 160026-0003  
 Service Connector: 13509990  
 Description: 12-Way F 1.2, 2.8 stAK50h Series( L-PU)

### Terminal Part Information

Terminal Type ID	Terminated Lead	Diagnostic Test Probe	Terminal Removal Tool
I	84729890	J-35616-12 (BU)	J-38125-215A
II	87814662	J-35616-4A (PU)	J-38125-557

### K219 Lighting Control Module X1

Pin	Size	Color	Circuit	Function	Terminal Type ID	Option
1	0.5	WH / YE	1254	Left Front Park Lamp Control	I	—
2	—	—	—	Not Occupied	—	—
3	0.5	GN / WH	24	Backup Lamp Control	I	—
4	—	—	—	Not Occupied	—	—
5	0.5	BU / WH	1314	Left Front Turn Signal Lamp Control	I	—
6	0.5	BN / GY	5061	Left Front Fog Lamp Control	I	—
7	0.5	GN / YE	6846	Rear License Plate Lamp Control	I	—
8	0.35	GY / BU	7538	Left Front DRL Control	I	—
9	0.5	RD / VT	7140	Battery Positive Voltage	II	—
10	0.75	YE	712	Left Headlamp Low Beam Control	II	—
11	—	—	—	Not Occupied	—	—
12	0.75	WH	711	Left Headlamp High Beam Control	II	—

## K219 Lighting Control Module X2

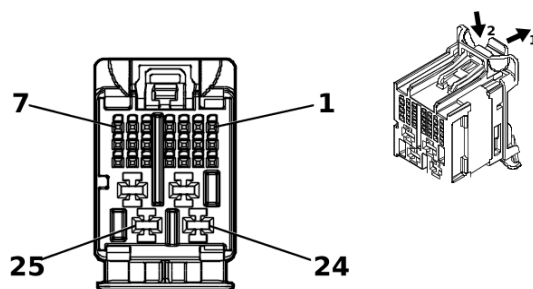

5203807

### Connector Part Information

Harness Type: Body Wiring Harness

OEM Connector: 160027-0012

Service Connector: 13534966

Description: 25-Way F 0.5 MQS, 2.8 MCP Series( GY with GY Inner Connector)

### Terminal Part Information

Terminal Type ID	Terminated Lead	Diagnostic Test Probe	Terminal Removal Tool
I	19370262	EL-35616-58 (BK)	EL-38125-58
II	87814662	J-35616-4A (PU)	J-38125-557

### K219 Lighting Control Module X2

Pin	Size	Color	Circuit	Function	Terminal Type ID	Option
1 - 2	—	—	—	Not Occupied	—	—
3	0.35	BN / GY	2268	Windshield Washer Relay Control	I	—
4	0.35	BU / BN	38	Backup Lamp Relay Control	I	—
5 - 9	—	—	—	Not Occupied	—	—
10	0.35	BN / GN	196	Windshield Wiper Motor Park Switch Signal	I	—
11	0.35	VT / BK	6568	Front Turn Signal Lamp Feedback Signal	I	—
12	0.35	GY	91	Windshield Wiper Motor Relay Coil Control	I	—
13	—	—	—	Not Occupied	—	—
14	0.35	VT	185	Low Washer Fluid Indicator Control	I	—
15 - 18	—	—	—	Not Occupied	—	—
19	0.35	WH / BN	7055	Auxiliary Park Lamp Relay Control	I	—
20	0.35	WH / YE	7545	Right Front Turn Signal Lamp Feedback Signal	I	—
21	0.35	WH / VT	860	Windshield Wiper Switch High Signal	I	—
22	0.5	RD / GN	7740	Battery Positive Voltage	II	—
23	0.5	RD / BU	840	Battery Positive Voltage	II	—
24 - 25	—	—	—	Not Occupied	—	—



## K219 Lighting Control Module X3

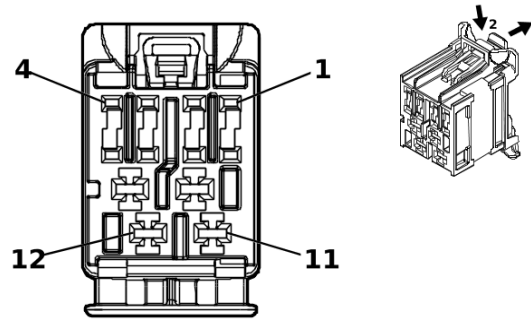

5203797

### Connector Part Information

Harness Type: Body Wiring Harness  
 OEM Connector: 160026-0002  
 Service Connector: 13509989  
 Description: 12-Way F 1.2, 2.8 stAK50h Series( GN)

### Terminal Part Information

Terminal Type ID	Terminated Lead	Diagnostic Test Probe	Terminal Removal Tool
I	84729890	J-35616-12 (BU)	J-38125-215A
II	87814662	J-35616-4A (PU)	J-38125-557

### K219 Lighting Control Module X3

Pin	Size	Color	Circuit	Function	Terminal Type ID	Option
1	0.35	BU / BN	7539	Right Front DRL Control	I	—
2 - 3	—	—	—	Not Occupied	—	—
4	0.5	BU / GN	1253	Right Front Park Lamp Control	I	—
5	—	—	—	Not Occupied	—	—
6	0.75	BU / VT	1335	Right Rear Turn Signal Lamp Control 2	I	—
7	0.35	BU / YE	7761	Backup Illumination Lamp Control	I	—
8	—	—	—	Not Occupied	—	—
9	1.5	RD / BU	540	Battery Positive Voltage	II	—
10	1.5	RD / BN	1440	Battery Positive Voltage	II	—
11	0.75	WH	311	Right Headlamp High Beam Control	II	—
12	1	YE	312	Right Headlamp Low Beam Control	II	—

## K219 Lighting Control Module X4

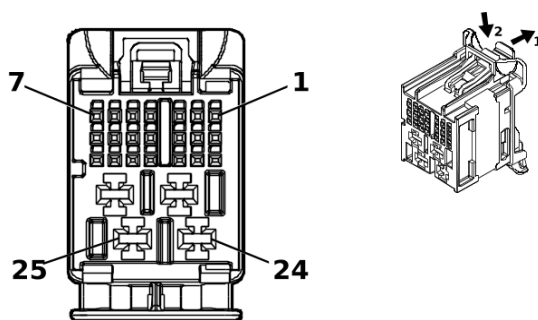

5203416

### Connector Part Information

Harness Type: Body Wiring Harness

OEM Connector: 160027-0015

Service Connector: 13534969

Description: 25-Way F 0.5 MQS, 2.8 MCP Series( PU with GY Inner Connector)

### Terminal Part Information

Terminal Type ID	Terminated Lead	Diagnostic Test Probe	Terminal Removal Tool
I	19370262	EL-35616-58 (BK)	EL-38125-58
II	87814662	J-35616-4A (PU)	J-38125-557

### K219 Lighting Control Module X4

Pin	Size	Color	Circuit	Function	Terminal Type ID	Option
1 - 2	—	—	—	Not Occupied	—	—
3	0.35	BU / YE	4979	AUTOSAR CAN Bus [+] 2 Serial Data	I	—
4	0.35	WH	4978	AUTOSAR CAN Bus [-] 2 Serial Data	I	—
5	0.35	BU / YE	4979	AUTOSAR CAN Bus [+] 2 Serial Data	I	—
6	0.35	WH	4978	AUTOSAR CAN Bus [-] 2 Serial Data	I	—
7	0.35	WH / BU	6311	Cruise/ETC/TCC Brake Signal	I	—
8 - 9	—	—	—	Not Occupied	—	—
10	0.35	WH	4978	AUTOSAR CAN Bus [-] 2 Serial Data	I	—
11	0.35	BU / YE	4979	AUTOSAR CAN Bus [+] 2 Serial Data	I	—
12 - 21	—	—	—	Not Occupied	—	—
22	1	RD / BN	1140	Battery Positive Voltage	II	—
23	1	BK / WH	1551	Signal Ground	II	—
24	0.5	RD / GN	1540	Battery Positive Voltage	II	—
25	1	BK / WH	1451	Signal Ground	II	—

## K219 Lighting Control Module X5

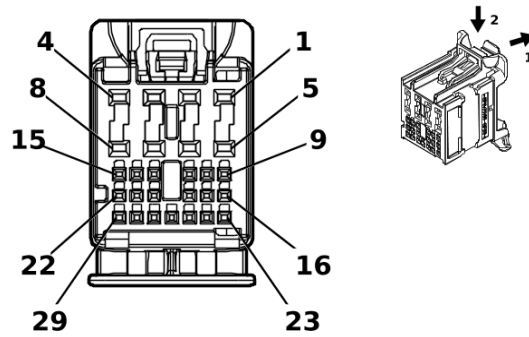

5203373

### Connector Part Information

Harness Type: Body Wiring Harness

OEM Connector: 160029-0013

Service Connector: 13534975

Description: 29-Way F 0.5 NANO, 1.2 MCON, stAK50h Series( BU with GY Inner Connector)

### Terminal Part Information

Terminal Type ID	Terminated Lead	Diagnostic Test Probe	Terminal Removal Tool
I	19370262	EL-35616-58 (BK)	EL-38125-58
II	84729890	J-35616-12 (BU)	J-38125-215A

### K219 Lighting Control Module X5

Pin	Size	Color	Circuit	Function	Terminal Type ID	Option
1	0.5	WH / GN	5966	Approach Lamp Control	II	—
2	0.75	BN / GY	6995	Right Rear Park Lamp Control	II	—
3	0.5	GY / BU	7762	Cargo Lamp Control	II	—
4	0.5	WH / VT	1430	Exterior Courtesy Lamp Control	II	—
5	0.5	YE / GN	2024	Animation Lighting Control	II	—
6	0.75	BN / BU	6993	Left Rear Park Lamp Control	II	—
7	0.5	GN / VT	1315	Right Front Turn Signal Lamp Control	II	—
8	0.75	BU / WH	1334	Left Rear Turn Signal Lamp Control 2	II	—
9	0.35	GN / GY	2115	Right Turn Signal Lamp Control 2	I	—
10	0.35	WH / GY	2114	Left Turn Signal Lamp Control 2	I	—
11	0.35	GY	1715	Windshield Wiper Switch High Signal	I	—
13	0.35	GN / BN	319	Right Rear Trailer Stop/Turn Lamp Control	I	—
14	—	—	—	Not Occupied	—	—
15	0.35	WH / GY	2935	Task Lamp Switch Signal	I	—
16	0.35	YE / WH	2934	Task Lamp Control Right	I	—
17	—	—	—	Not Occupied	—	—
18	0.35	VT / WH	239	Run/Crank Ignition 1 Voltage	I	—
20 - 22	—	—	—	Not Occupied	—	—
23	0.35	WH / VT	6567	Rear Turn Signal Lamp Feedback Signal	I	—
24	0.35	WH / BK	7544	Right Rear Turn Signal Lamp Feedback Signal	I	—
25	0.35	BN / YE	820	Center High Mounted Stop Lamp Supply Voltage	I	—

**6-462 Electrical Component and Inline Harness Connector End Views****K219 Lighting Control Module X5 (cont'd)**

Pin	Size	Color	Circuit	Function	Terminal Type ID	Option
26 - 27	—	—	—	Not Occupied	—	—
28	0.35	YE / GY	2933	Task Lamp Control Left	I	—
29	0.35	YE / BU	318	Left Rear Trailer Stop/Turn Lamp Control	I	—

## M4 Air Inlet Valve Actuator

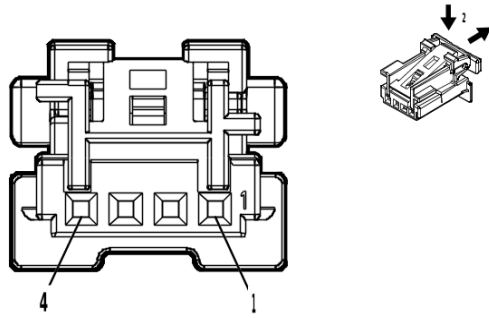

4997407

### Connector Part Information

Harness Type: Heater Wiring Harness  
 OEM Connector: 2294218-1  
 Service Connector: Service by Harness - See Part Catalog  
 Description: 4-Way F 0.64 Micro-Quadlock Series( BK)

### Terminal Part Information

Terminal Type ID	Terminated Lead	Diagnostic Test Probe	Terminal Removal Tool
I	Not required	J-35616-64B (L-BU)	No Tool Required

### M4 Air Inlet Valve Actuator

Pin	Size	Color	Circuit	Function	Terminal Type ID	Option
1	0.35	BK	1050	Ground	I	—
2	0.35	BU	2852	Body Control Module LIN Bus 6	I	—
3	0.35	BK	1050	Ground	I	—
4	0.35	RD	4634	HVAC Remote Enable Signal	I	—

**M6L Temperature Valve Actuator - Left**

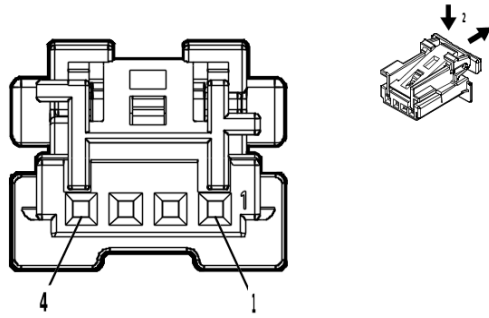

4997407

**Connector Part Information**

Harness Type: Heater Wiring Harness  
 OEM Connector: 2294218-1  
 Service Connector: Service by Harness - See Part Catalog  
 Description: 4-Way F 0.64 Micro-Quadlock Series( BK)

**Terminal Part Information**

Terminal Type ID	Terminated Lead	Diagnostic Test Probe	Terminal Removal Tool
I	Not required	J-35616-64B (L-BU)	No Tool Required

**M6L Temperature Valve Actuator - Left**

Pin	Size	Color	Circuit	Function	Terminal Type ID	Option
1	0.35	BK	1050	Ground	I	—
2	0.35	BU	2852	Body Control Module LIN Bus 6	I	—
3	0.35	BK	1050	Ground	I	—
4	0.35	RD	4634	HVAC Remote Enable Signal	I	—

**M6PL Programmable Temperature Valve Actuator - Left**

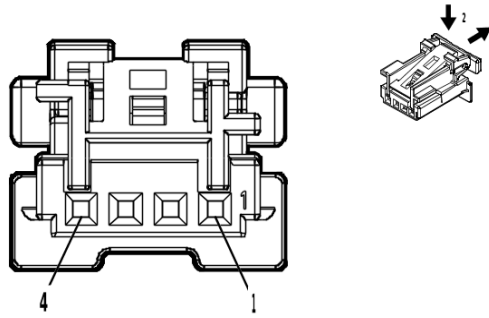

4997407

**Connector Part Information**

Harness Type: Heater Wiring Harness  
 OEM Connector: 2294218-1  
 Service Connector: Service by Harness - See Part Catalog  
 Description: 4-Way F 0.64 Micro-Quadlock Series( BK)

**Terminal Part Information**

Terminal Type ID	Terminated Lead	Diagnostic Test Probe	Terminal Removal Tool
I	Not required	J-35616-64B (L-BU)	No Tool Required

**M6PL Programmable Temperature Valve Actuator - Left**

Pin	Size	Color	Circuit	Function	Terminal Type ID	Option
1	0.35	BK	1050	Ground	I	—
2	0.35	BU	2852	Body Control Module LIN Bus 6	I	—
3	0.35	BK	1050	Ground	I	—
4	0.35	RD	4634	HVAC Remote Enable Signal	I	—

**M6PR Programmable Temperature Valve Actuator - Right**

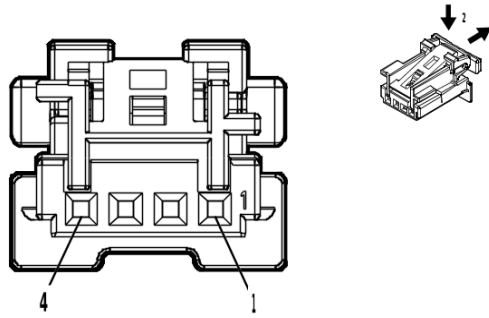

4997407

**Connector Part Information**

Harness Type: Heater Wiring Harness  
 OEM Connector: 2294218-1  
 Service Connector: Service by Harness - See Part Catalog  
 Description: 4-Way F 0.64 Micro-Quadlock Series( BK)

**Terminal Part Information**

Terminal Type ID	Terminated Lead	Diagnostic Test Probe	Terminal Removal Tool
I	Not required	J-35616-64B (L-BU)	No Tool Required

**M6PR Programmable Temperature Valve Actuator - Right**

Pin	Size	Color	Circuit	Function	Terminal Type ID	Option
1	0.35	BK	1050	Ground	I	—
2	0.35	BU	2852	Body Control Module LIN Bus 6	I	—
3	—	—	—	Not Occupied	—	—
4	0.35	RD	4634	HVAC Remote Enable Signal	I	—



**M6R Temperature Valve Actuator - Right (CJ2)**

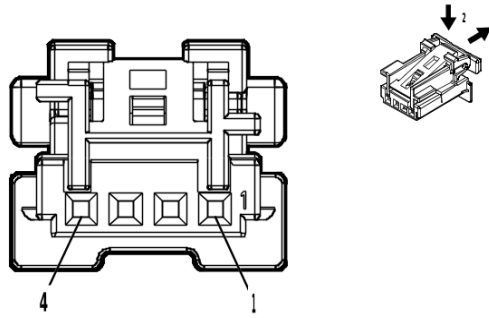

4997407

**Connector Part Information**

Harness Type: Heater Wiring Harness  
 OEM Connector: 2294218-1  
 Service Connector: Service by Harness - See Part Catalog  
 Description: 4-Way F 0.64 Micro-Quadlock Series( BK)

**Terminal Part Information**

Terminal Type ID	Terminated Lead	Diagnostic Test Probe	Terminal Removal Tool
I	Not required	J-35616-64B (L-BU)	No Tool Required

**M6R Temperature Valve Actuator - Right (CJ2)**

Pin	Size	Color	Circuit	Function	Terminal Type ID	Option
1	0.35	BK	1050	Ground	I	—
2	0.35	BU	2852	Body Control Module LIN Bus 6	I	—
3	—	—	—	Not Occupied	—	—
4	0.35	RD	4634	HVAC Remote Enable Signal	I	—

**M8 Blower Motor**

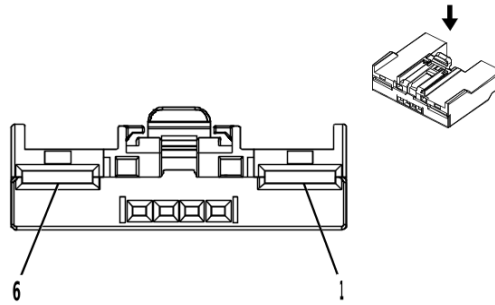

2904463

**Connector Part Information**

Harness Type: Instrument Panel Wiring Harness  
 OEM Connector: 7287-9355-30  
 Service Connector: 19356432  
 Description: 6-Way F 0.64 GET, 6.3 Series( BK)

**Terminal Part Information**

Terminal Type ID	Terminated Lead	Diagnostic Test Probe	Terminal Removal Tool
I	Not required	J-35616-42 (RD)	No Tool Required
II	Not required	J-35616-64B (L-BU)	No Tool Required

**M8 Blower Motor**

Pin	Size	Color	Circuit	Function	Terminal Type ID	Option
1	4	RD / GY	1740	Battery Positive Voltage	I	—
2	0.35	BU / GY	754	Blower Motor Speed Control	II	—
3	0.35	GN / BU	761	Blower Speed Feedback Signal	II	—
4 - 5	—	—	—	Not Occupied	—	—
6	4	BK	1050	Ground	I	—

## M10 Charge Air Cooler Coolant Pump

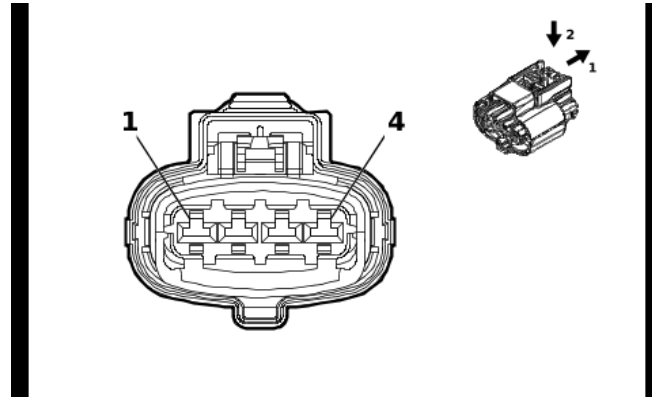

5869064

### Connector Part Information

Harness Type: Engine Wiring Harness  
 OEM Connector: 35133588  
 Service Connector: 19371209  
 Description: 4-Way F 2.8 CTS Series, Sealed( BK)

### Terminal Part Information

Terminal Type ID	Terminated Lead	Diagnostic Test Probe	Terminal Removal Tool
I	Not required	J-35616-4A (PU)	No Tool Required

### M10 Charge Air Cooler Coolant Pump

Pin	Size	Color	Circuit	Function	Terminal Type ID	Option
1	1	VT / BU	5294	Powertrain Main Relay Fused Supply Voltage 5	I	—
2	0.5	GN / VT	4621	Engine Control Module LIN Bus 1	I	—
3	—	—	—	Not Occupied	—	—
4	1	BK	6150	Engine Odd Bank Ground	I	—

## M14A Pickup Box Endgate Lock Actuator

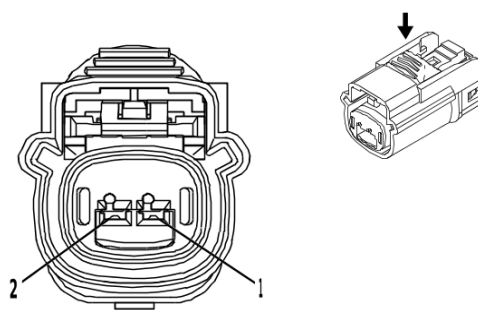

4332222

### Connector Part Information

Harness Type: Endgate Wiring Harness  
 OEM Connector: 15514573  
 Service Connector: Service by Harness - See Part Catalog  
 Description: 2-Way F 1.5 OCS Series, Sealed( BK)

### Terminal Part Information

Terminal Type ID	Terminated Lead	Diagnostic Test Probe	Terminal Removal Tool
I	Not required	J-35616-2A (GY)	No Tool Required

### M14A Pickup Box Endgate Lock Actuator

Pin	Size	Color	Circuit	Function	Terminal Type ID	Option
1	1	GN	1299	Major Endgate Motor Control	I	—
2	1	YE / BK	7730	Major Endgate Motor Low Reference	I	—

**M26 Front Drive Axle Actuator (NP0 / NQH)**

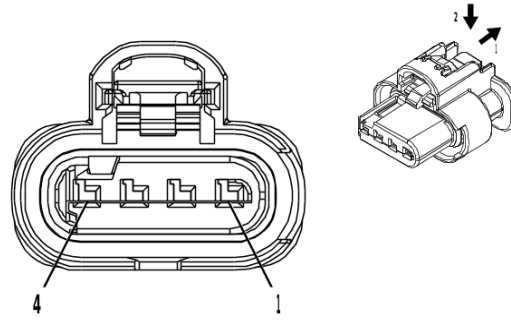

4210809

**Connector Part Information**

Harness Type: Transfer Case Selector Shift Control Switch Wiring Harness Extension Harness  
 OEM Connector: 1-2296696-1  
 Service Connector: Service by Harness - See Part Catalog  
 Description: 4-Way F 1.2 MCON-CB Series, Sealed( BK)

**Terminal Part Information**

Terminal Type ID	Terminated Lead	Diagnostic Test Probe	Terminal Removal Tool
I	Not required	J-35616-12 (BU)	No Tool Required

**M26 Front Drive Axle Actuator (NP0 / NQH)**

Pin	Size	Color	Circuit	Function	Terminal Type ID	Option
1	0.5	GN	8016	Secondary Axle Motor Control	I	—
2	0.5	GY / BK	1570	Front Axle Actuator Control	I	—
3	0.5	YE / WH	1695	4WD Locked Range Indicator Control	I	—
4	0.5	BK	450	Ground	I	—

**M37 Mode Valve Actuator**

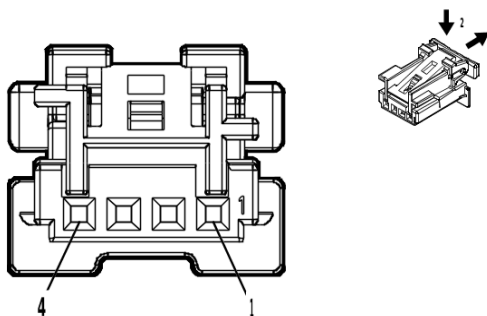

4997407

**Connector Part Information**

Harness Type: Heater Wiring Harness  
 OEM Connector: 2294218-1  
 Service Connector: Service by Harness - See Part Catalog  
 Description: 4-Way F 0.64 Micro-Quadlock Series( BK)

**Terminal Part Information**

Terminal Type ID	Terminated Lead	Diagnostic Test Probe	Terminal Removal Tool
I	Not required	J-35616-64B (L-BU)	No Tool Required

**M37 Mode Valve Actuator**

Pin	Size	Color	Circuit	Function	Terminal Type ID	Option
1	0.35	BK	1050	Ground	I	—
2	0.35	BU	2852	Body Control Module LIN Bus 6	I	—
3	—	—	—	Not Occupied	—	—
4	0.35	RD	4634	HVAC Remote Enable Signal	I	—

**M50D Front Seat Tilt Adjuster Actuator - Driver (A2X - A45)**

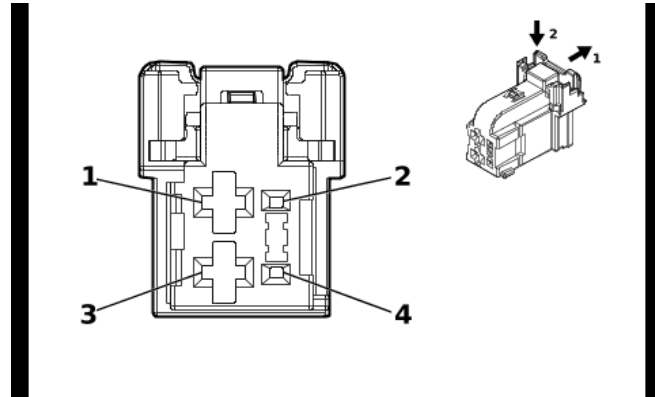

5410027

**Connector Part Information**

Harness Type: Front Seat Wiring Harness - Driver  
 OEM Connector: 2316171-1  
 Service Connector: Service by Harness - See Part Catalog  
 Description: 4-Way F 0.64, 2.8 Series( BK)

**Terminal Part Information**

Terminal Type ID	Terminated Lead	Diagnostic Test Probe	Terminal Removal Tool
I	Not required	J-35616-35 (VT)	No Tool Required

**M50D Front Seat Tilt Adjuster Actuator - Driver (A2X - A45)**

Pin	Size	Color	Circuit	Function	Terminal Type ID	Option
1	1.5	BU / VT	287	Driver Seat Front Vertical Motor Down Control	I	—
2	—	—	—	Not Occupied	—	—
3	1.5	GN / BN	286	Driver Seat Front Vertical Motor Up Control	I	—
4	—	—	—	Not Occupied	—	—

**M50D Front Seat Tilt Adjuster Actuator - Driver (A2X & A45)**

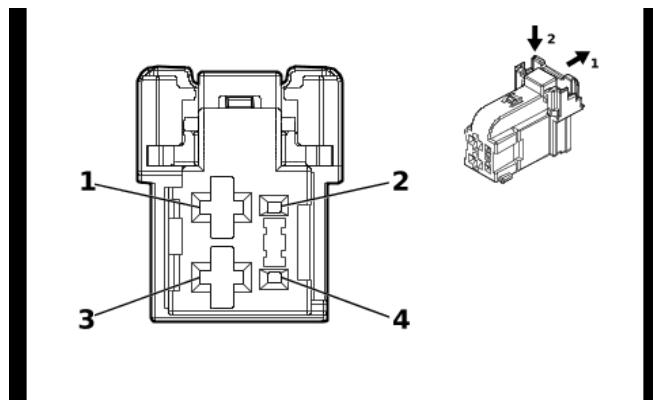

5410027

**Connector Part Information**

Harness Type: Front Seat Wiring Harness - Driver  
 OEM Connector: 2316171-1  
 Service Connector: Service by Harness - See Part Catalog  
 Description: 4-Way F 0.64, 2.8 Series( BK)

**Terminal Part Information**

Terminal Type ID	Terminated Lead	Diagnostic Test Probe	Terminal Removal Tool
I	Not required	J-35616-35 (VT)	No Tool Required

**M50D Front Seat Tilt Adjuster Actuator - Driver (A2X & A45)**

Pin	Size	Color	Circuit	Function	Terminal Type ID	Option
1	1.5	BU / VT	287	Driver Seat Front Vertical Motor Down Control	I	—
2	—	—	—	Not Occupied	—	—
3	1.5	GN / BN	286	Driver Seat Front Vertical Motor Up Control	I	—
4	—	—	—	Not Occupied	—	—



**M50P Front Seat Tilt Adjuster Actuator - Passenger**

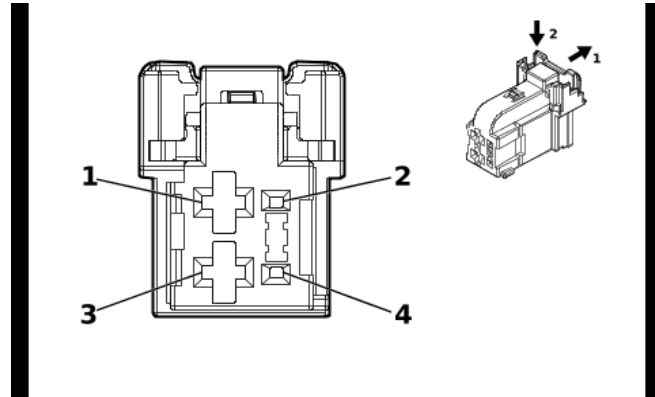

5410027

**Connector Part Information**

Harness Type: Front Seat Wiring Harness - Passenger  
 OEM Connector: 2316171-1  
 Service Connector: Service by Harness - See Part Catalog  
 Description: 4-Way F 0.64, 2.8 Series( BK)

**Terminal Part Information**

Terminal Type ID	Terminated Lead	Diagnostic Test Probe	Terminal Removal Tool
I	Not required	J-35616-35 (VT)	No Tool Required

**M50P Front Seat Tilt Adjuster Actuator - Passenger**

Pin	Size	Color	Circuit	Function	Terminal Type ID	Option
1	1.5	GN / VT	297	Passenger Seat Front Vertical Motor Up Control	I	—
2	—	—	—	Not Occupied	—	—
3	1.5	GN / BU	298	Passenger Seat Front Vertical Motor Down Control	I	—
4	—	—	—	Not Occupied	—	—

**M51D Front Seat Adjuster Actuator - Driver**

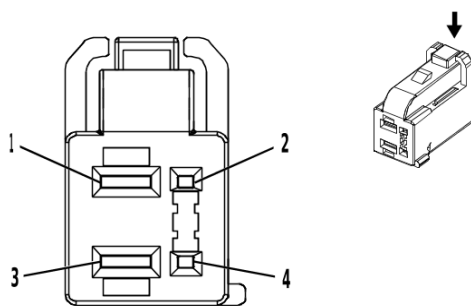

3683652

**Connector Part Information**

Harness Type: Front Seat Wiring Harness - Driver  
 OEM Connector: 13583828  
 Service Connector: Service by Harness - See Part Catalog  
 Description: 4-Way F 0.64, 2.8 Series( BK)

**Terminal Part Information**

Terminal Type ID	Terminated Lead	Diagnostic Test Probe	Terminal Removal Tool
I	Not required	J-35616-4A (PU)	No Tool Required

**M51D Front Seat Adjuster Actuator - Driver**

Pin	Size	Color	Circuit	Function	Terminal Type ID	Option
1	1.5	GY / GN	284	Driver Seat Horizontal Motor Rearward Control	I	—
2	—	—	—	Not Occupied	—	—
3	1.5	YE / BU	285	Driver Seat Horizontal Motor Forward Control	I	—
4	—	—	—	Not Occupied	—	—

**M51P Front Seat Adjuster Actuator - Passenger**

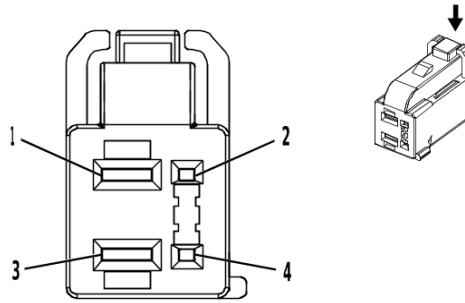

3683652

**Connector Part Information**

Harness Type: Front Seat Wiring Harness - Passenger  
 OEM Connector: 13583828  
 Service Connector: Service by Harness - See Part Catalog  
 Description: 4-Way F 0.64, 2.8 Series( BK)

**Terminal Part Information**

Terminal Type ID	Terminated Lead	Diagnostic Test Probe	Terminal Removal Tool
I	Not required	J-35616-4A (PU)	No Tool Required

**M51P Front Seat Adjuster Actuator - Passenger**

Pin	Size	Color	Circuit	Function	Terminal Type ID	Option
1	1.5	YE / BU	290	Passenger Seat Horizontal Motor Rearward Control	I	—
2	—	—	—	Not Occupied	—	—
3	1.5	YE / WH	296	Passenger Seat Horizontal Motor Forward Control	I	—
4	—	—	—	Not Occupied	—	—

**M53D Front Seat Back Lumbar Motor - Driver**

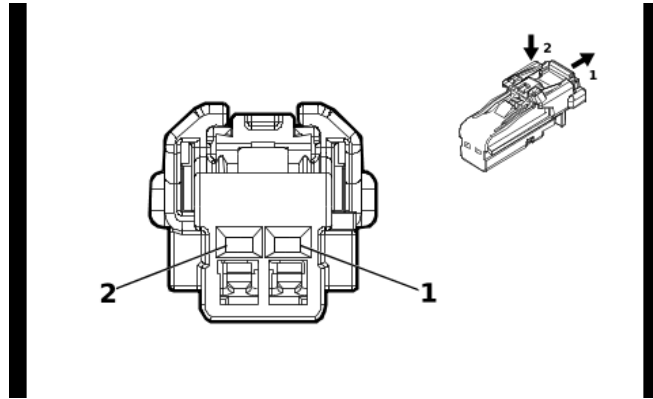

4115691

**Connector Part Information**

Harness Type: Front Seat Wiring Harness - Driver  
 OEM Connector: 6098-8988  
 Service Connector: Service by Harness - See Part Catalog  
 Description: 2-Way F 1.2 MCON Series( BK)

**Terminal Part Information**

Terminal Type ID	Terminated Lead	Diagnostic Test Probe	Terminal Removal Tool
I	Not required	J-35616-16 (L-GN)	No Tool Required

**M53D Front Seat Back Lumbar Motor - Driver**

Pin	Size	Color	Circuit	Function	Terminal Type ID	Option
1	0.75	BU	611	Driver Seat Lumbar Support Motor Forward Control	I	—
2	0.75	VT	610	Driver Seat Lumbar Support Motor Backward Control	I	—

### M53P Front Seat Back Lumbar Motor - Passenger

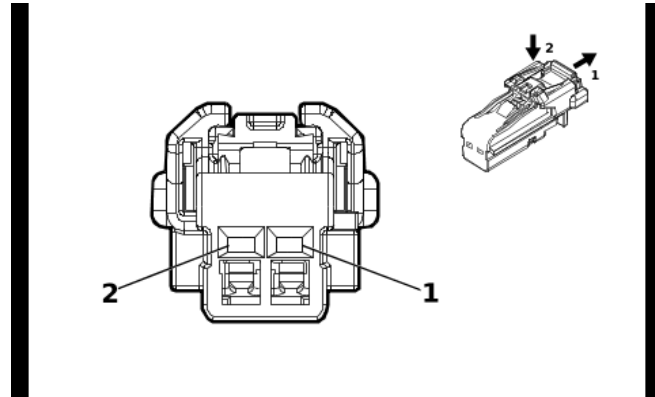

4115691

#### Connector Part Information

Harness Type: Front Seat Wiring Harness - Passenger  
 OEM Connector: 6098-8988  
 Service Connector: Service by Harness - See Part Catalog  
 Description: 2-Way F 1.2 MCON Series( BK)

#### Terminal Part Information

Terminal Type ID	Terminated Lead	Diagnostic Test Probe	Terminal Removal Tool
I	Not required	J-35616-16 (L-GN)	No Tool Required

#### M53P Front Seat Back Lumbar Motor - Passenger

Pin	Size	Color	Circuit	Function	Terminal Type ID	Option
1	0.75	BU	211	Passenger Seat Lumbar Support Motor Forward Control	I	—
2	0.75	VT	210	Passenger Seat Lumbar Support Motor Backward Control	I	—

**M55D Front Seat Vertical Adjuster Actuator - Driver**

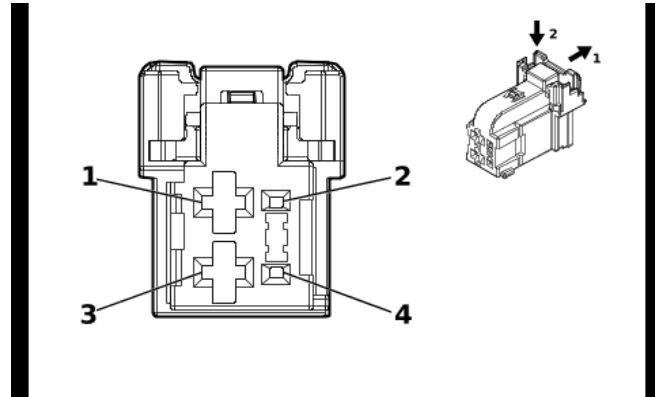

5410027

**Connector Part Information**

Harness Type: Front Seat Wiring Harness - Driver  
 OEM Connector: 2316171-1  
 Service Connector: Service by Harness - See Part Catalog  
 Description: 4-Way F 0.64, 2.8 Series( BK)

**Terminal Part Information**

Terminal Type ID	Terminated Lead	Diagnostic Test Probe	Terminal Removal Tool
I	Not required	J-35616-35 (VT)	No Tool Required

**M55D Front Seat Vertical Adjuster Actuator - Driver**

Pin	Size	Color	Circuit	Function	Terminal Type ID	Option
1	1.5	GY / BU	283	Driver Seat Rear Vertical Motor Down Control	I	—
2	—	—	—	Not Occupied	—	—
3	1.5	YE	282	Driver Seat Rear Vertical Motor Up Control	I	—
4	—	—	—	Not Occupied	—	—

**M55P Front Seat Vertical Adjuster Actuator - Passenger**

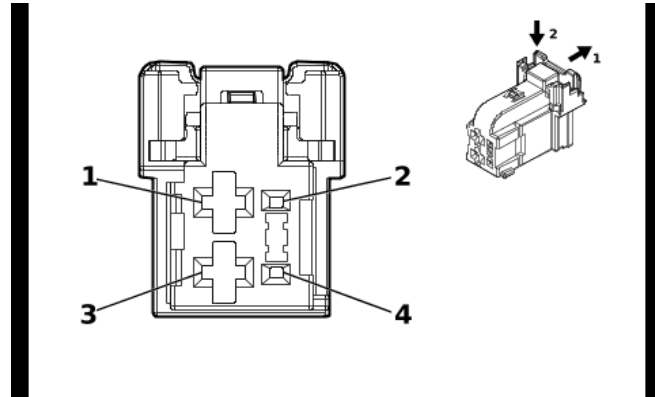

5410027

**Connector Part Information**

Harness Type: Front Seat Wiring Harness - Passenger  
 OEM Connector: 2316171-1  
 Service Connector: Service by Harness - See Part Catalog  
 Description: 4-Way F 0.64, 2.8 Series( BK)

**Terminal Part Information**

Terminal Type ID	Terminated Lead	Diagnostic Test Probe	Terminal Removal Tool
I	Not required	J-35616-35 (VT)	No Tool Required

**M55P Front Seat Vertical Adjuster Actuator - Passenger**

Pin	Size	Color	Circuit	Function	Terminal Type ID	Option
1	1.5	BU / WH	289	Passenger Seat Rear Vertical Motor Down Control	I	—
2	—	—	—	Not Occupied	—	—
3	1.5	GN / WH	288	Passenger Seat Rear Vertical Motor Up Control	I	—
4	—	—	—	Not Occupied	—	—

**M56D Front Seat Recliner Actuator - Driver (A45)**

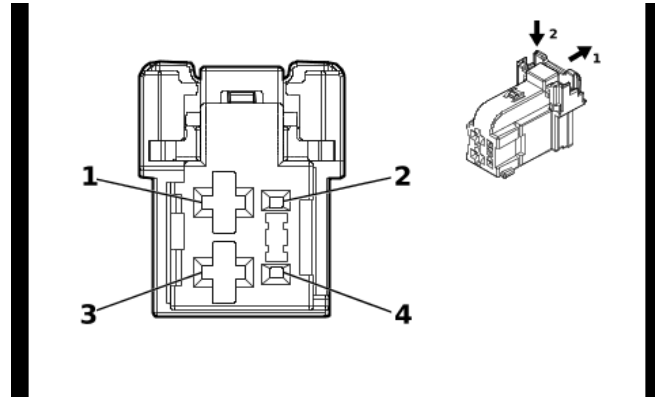

5410027

**Connector Part Information**

Harness Type: Front Seat Wiring Harness - Driver  
 OEM Connector: 2316171-1  
 Service Connector: Service by Harness - See Part Catalog  
 Description: 4-Way F 0.64, 2.8 Series( BK)

**Terminal Part Information**

Terminal Type ID	Terminated Lead	Diagnostic Test Probe	Terminal Removal Tool
I	Not required	J-35616-35 (VT)	No Tool Required

**M56D Front Seat Recliner Actuator - Driver (A45)**

Pin	Size	Color	Circuit	Function	Terminal Type ID	Option
1	1.5	GN / YE	276	Driver Seat Recline Motor Forward Control	I	—
2	—	—	—	Not Occupied	—	—
3	1.5	BU / YE	277	Driver Seat Recline Motor Rearward Control	I	—
4	—	—	—	Not Occupied	—	—



**M56P Front Seat Recliner Actuator - Passenger (AKE)**

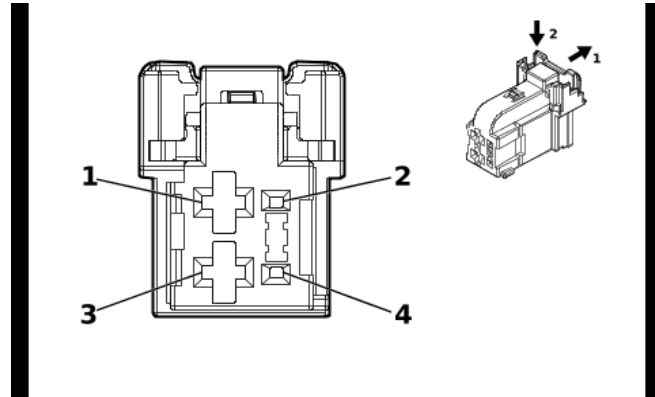

5410027

**Connector Part Information**

Harness Type: Front Seat Wiring Harness - Passenger  
 OEM Connector: 2316171-1  
 Service Connector: Service by Harness - See Part Catalog  
 Description: 4-Way F 0.64, 2.8 Series( BK)

**Terminal Part Information**

Terminal Type ID	Terminated Lead	Diagnostic Test Probe	Terminal Removal Tool
I	Not required	J-35616-35 (VT)	No Tool Required

**M56P Front Seat Recliner Actuator - Passenger (AKE)**

Pin	Size	Color	Circuit	Function	Terminal Type ID	Option
1	1.5	GN	76	Passenger Seat Recline Motor Forward Control	I	—
2	—	—	—	Not Occupied	—	—
3	1.5	BU / BN	77	Passenger Seat Recline Motor Rearward Control	I	—
4	—	—	—	Not Occupied	—	—

**M63 Rear Sliding Window Motor (A48)**

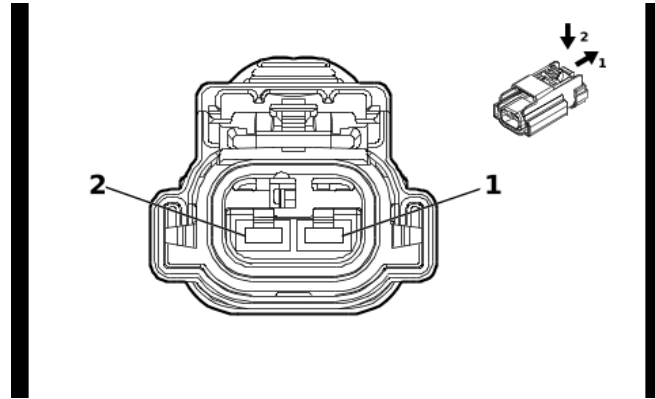

5795169

**Connector Part Information**

Harness Type: Body Wiring Harness  
 OEM Connector: 35286783  
 Service Connector: 19301518  
 Description: 2-Way F 2.8 APEX Series, Sealed( BK)

**Terminal Part Information**

Terminal Type ID	Terminated Lead	Diagnostic Test Probe	Terminal Removal Tool
I	Not required	J-35616-35 (VT)	No Tool Required

**M63 Rear Sliding Window Motor (A48)**

Pin	Size	Color	Circuit	Function	Terminal Type ID	Option
1	2	YE	7454	Window Motor Rear Auxiliary Close Control	I	—
2	2	VT / YE	7453	Window Motor Rear Auxiliary Open Control	I	—

**M64 Starter X1 (L3B)**

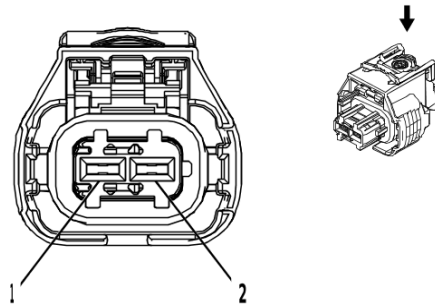

2577394

**Connector Part Information**

Harness Type: Engine Wiring Harness  
 OEM Connector: 1 928 405 714  
 Service Connector: 13384371  
 Description: 2-Way F 2.8 Series, Sealed( BK)

**Terminal Part Information**

Terminal Type ID	Terminated Lead	Diagnostic Test Probe	Terminal Removal Tool
I	Not required	J-35616-35 (VT)	No Tool Required

**M64 Starter X1 (L3B)**

Pin	Size	Color	Circuit	Function	Terminal Type ID	Option
1	2.5	YE	6	Starter Solenoid Crank Ignition Voltage	I	—
2	2.5	YE / GN	4358	Starter Pinion Solenoid Voltage	I	—

**M64 Starter X1 (L84 / L87)**

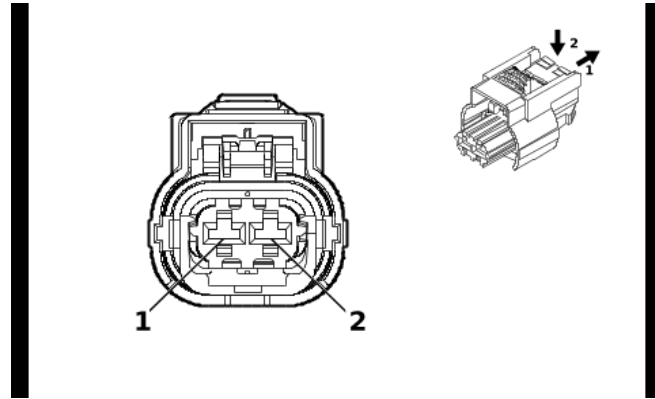

4992524

**Connector Part Information**

Harness Type: Engine Wiring Harness  
 OEM Connector: 35182447  
 Service Connector: 84941154  
 Description: 2-Way F 2.8 MCP Series, Sealed( BK)

**Terminal Part Information**

Terminal Type ID	Terminated Lead	Diagnostic Test Probe	Terminal Removal Tool
I	Not required	J-35616-4A (PU)	No Tool Required

**M64 Starter X1 (L84 / L87)**

Pin	Size	Color	Circuit	Function	Terminal Type ID	Option
1	2.5	YE	6	Starter Solenoid Crank Ignition Voltage	I	—
2	2.5	YE / GN	4358	Starter Pinion Solenoid Voltage	I	—

**M64 Starter X1 (LZ0)**

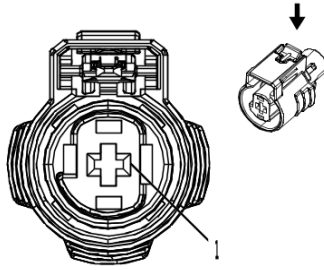

2717134

**Connector Part Information**

Harness Type: Engine Wiring Harness  
 OEM Connector: 2098198-5  
 Service Connector: 19300471  
 Description: 1-Way F 2.8 MCP Series, Sealed( BK)

**Terminal Part Information**

Terminal Type ID	Terminated Lead	Diagnostic Test Probe	Terminal Removal Tool
I	Not required	J-35616-4A (PU)	No Tool Required

**M64 Starter X1 (LZ0)**

Pin	Size	Color	Circuit	Function	Terminal Type ID	Option
1	2.5	YE	6	Starter Solenoid Crank Ignition Voltage	I	—

**M64 Starter X2 (L3B)**

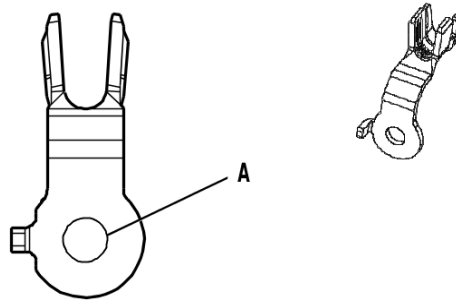

5020399

**Connector Part Information**

Harness Type: Starter Solenoid Cable  
 OEM Connector: 13516388  
 Service Connector: Service by Cable Assembly — See Part Catalog  
 Description: 1-Way Ring Terminal

**Terminal Part Information**

Terminal Type ID	Terminated Lead	Diagnostic Test Probe	Terminal Removal Tool
I	Not required	No Tool Required	No Tool Required

**M64 Starter X2 (L3B)**

Pin	Size	Color	Circuit	Function	Terminal Type ID	Option
A	35	RD / YE	2	Battery Positive Voltage	I	—

## M64 Starter X2 (L84 / L87)

—

### Connector Part Information

Harness Type: Starter Solenoid Cable  
 OEM Connector: 84406835  
 Service Connector: Service by Cable Assembly — See Part Catalog  
 Description: 1-Way F Ring Terminal

### Terminal Part Information

Terminal Type ID	Terminated Lead	Diagnostic Test Probe	Terminal Removal Tool
I	Not required	No Tool Required	No Tool Required

### M64 Starter X2 (L84 / L87)

Pin	Size	Color	Circuit	Function	Terminal Type ID	Option
A	35	RD / YE	2	Battery Positive Voltage	I	—

**M64 Starter X2 (LZ0)**

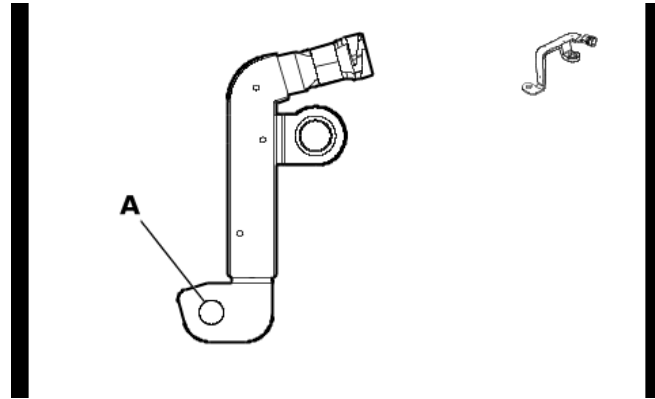

5911297

**Connector Part Information**

Harness Type: Starter Solenoid Cable  
 OEM Connector: 84892630  
 Service Connector: Service by Cable Assembly — See Part Catalog  
 Description: 1-Way Ring Terminal

**Terminal Part Information**

Terminal Type ID	Terminated Lead	Diagnostic Test Probe	Terminal Removal Tool
I	Not required	No Tool Required	No Tool Required

**M64 Starter X2 (LZ0)**

Pin	Size	Color	Circuit	Function	Terminal Type ID	Option
A	35	RD / YE	2	Battery Positive Voltage	I	—



### M65 Steering Column Telescope Actuator (N38)

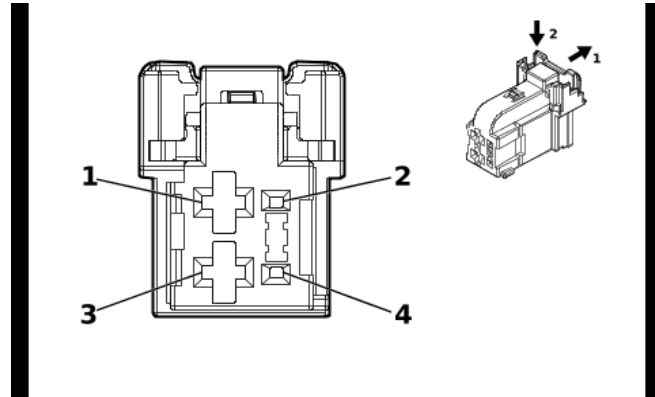

5410027

#### Connector Part Information

Harness Type: Steering Column Tilt and Telescope Wheel Actuator Motor Harness  
 OEM Connector: 2316171-1  
 Service Connector: Service by Harness - See Part Catalog  
 Description: 4-Way F 0.64, 2.8 Series( BK)

#### Terminal Part Information

Terminal Type ID	Terminated Lead	Diagnostic Test Probe	Terminal Removal Tool
I	Not required	No Tool Required	No Tool Required

#### M65 Steering Column Telescope Actuator (N38)

Pin	Size	Color	Circuit	Function	Terminal Type ID	Option
1	1	GN	2098	Steering Column Telescope Motor Forward Control	I	—
2	0.35	YE	2153	Steering Column Telescope Motor Signal	I	—
3	1	RD	2110	Steering Column Telescope Motor Rearward Control	I	—
4	0.35	WH	2152	Steering Column Telescope Motor Low Reference	I	—

**M68 Steering Column Tilt Wheel Actuator (N38)**

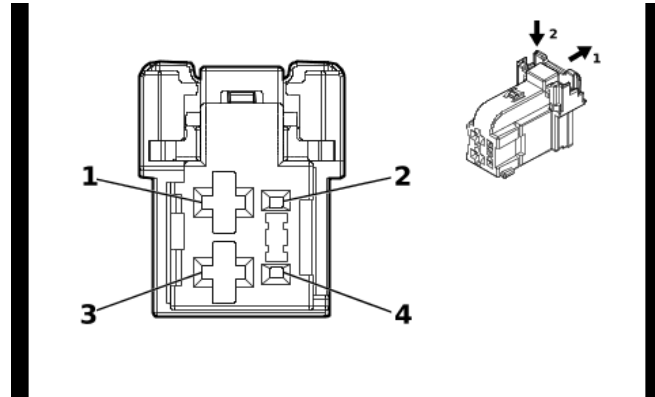

5410027

**Connector Part Information**

Harness Type: Steering Column Tilt and Telescope Wheel Actuator Motor Harness  
 OEM Connector: 2316171-1  
 Service Connector: Service by Harness - See Part Catalog  
 Description: 4-Way F 0.64, 2.8 Series( BK)

**Terminal Part Information**

Terminal Type ID	Terminated Lead	Diagnostic Test Probe	Terminal Removal Tool
I	Not required	No Tool Required	No Tool Required

**M68 Steering Column Tilt Wheel Actuator (N38)**

Pin	Size	Color	Circuit	Function	Terminal Type ID	Option
1	1	OG	2112	Steering Column Tilt Motor Down Control	I	—
2	0.35	BN	2154	Steering Column Tilt Motor Signal	I	—
3	1	VT	2111	Steering Column Tilt Motor Up Control	I	—
4	0.35	BU	2157	Steering Column Tilt Motor Low Reference	I	—

**M73A Front Seat Back Ventilation Blower - Driver**

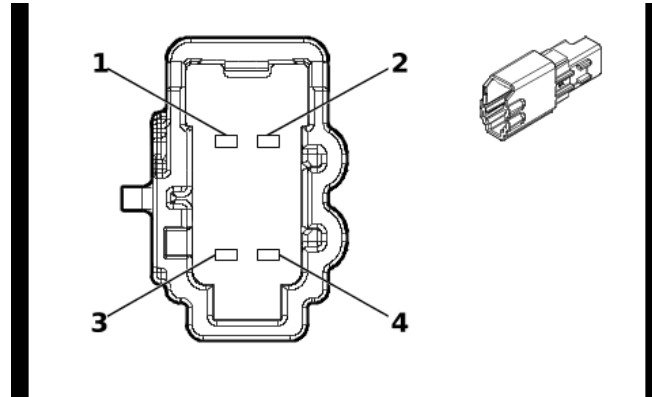

5423974

**Connector Part Information**

Harness Type: Front Seat Wiring Harness - Driver  
 OEM Connector: 6098-9049  
 Service Connector: Service by Harness - See Part Catalog  
 Description: 4-Way M 1.2 MCON Series( GY)

**Terminal Part Information**

Terminal Type ID	Terminated Lead	Diagnostic Test Probe	Terminal Removal Tool
I	Not required	J-35616-13 (BU)	No Tool Required
II	Not required	J-35616-17 (L-GN)	No Tool Required

**M73A Front Seat Back Ventilation Blower - Driver**

Pin	Size	Color	Circuit	Function	Terminal Type ID	Option
1	0.75	VT / WH	1139	Run/Crank Ignition 1 Voltage	I	—
2	0.5	GN / VT	5906	Driver Seat Blower Motor Control 1	II	—
3	0.75	BK	1550	Ground	I	—
4	—	—	—	Not Occupied	—	—

**M73B Front Seat Back Ventilation Blower - Passenger (KA1 & KQV)**

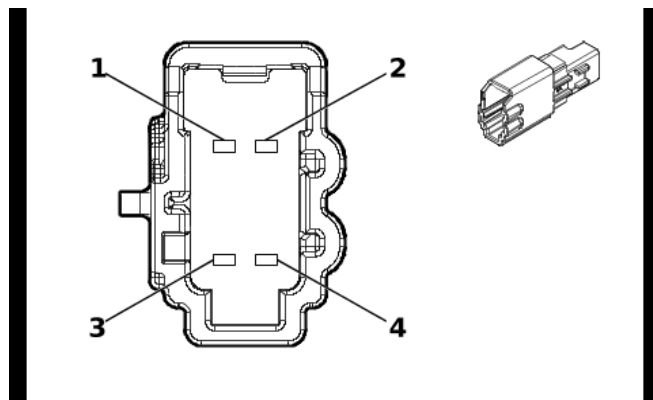

5423974

**Connector Part Information**

Harness Type: Front Seat Wiring Harness - Passenger  
 OEM Connector: 6098-9049  
 Service Connector: Service by Harness - See Part Catalog  
 Description: 4-Way M 1.2 MCON Series( GY)

**Terminal Part Information**

Terminal Type ID	Terminated Lead	Diagnostic Test Probe	Terminal Removal Tool
I	Not required	J-35616-13 (BU)	No Tool Required
II	Not required	J-35616-17 (L-GN)	No Tool Required

**M73B Front Seat Back Ventilation Blower - Passenger (KA1 & KQV)**

Pin	Size	Color	Circuit	Function	Terminal Type ID	Option
1	0.75	VT / WH	1139	Run/Crank Ignition 1 Voltage	I	—
2	0.5	VT / WH	5908	Passenger Seat Blower Motor Control 1	II	—
3	0.75	BK	1350	Ground	I	—
4	—	—	—	Not Occupied	—	—

**M73D Front Seat Cushion Ventilation Blower - Driver (KA1 & KQV)**

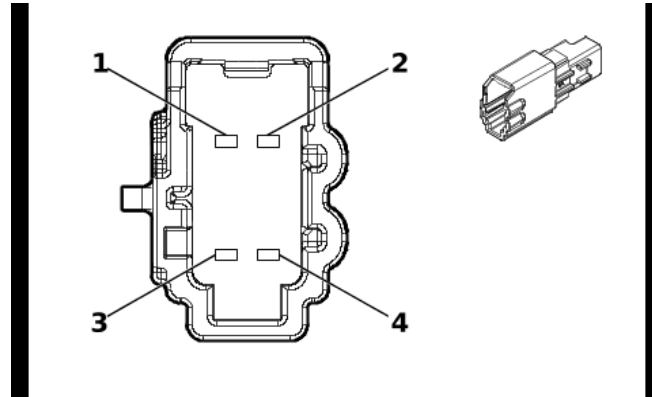

5423974

**Connector Part Information**

Harness Type: Front Seat Wiring Harness - Driver  
 OEM Connector: 6098-9049  
 Service Connector: Service by Harness - See Part Catalog  
 Description: 4-Way M 1.2 MCON Series( GY)

**Terminal Part Information**

Terminal Type ID	Terminated Lead	Diagnostic Test Probe	Terminal Removal Tool
I	Not required	J-35616-13 (BU)	No Tool Required
II	Not required	J-35616-17 (L-GN)	No Tool Required

**M73D Front Seat Cushion Ventilation Blower - Driver (KA1 & KQV)**

Pin	Size	Color	Circuit	Function	Terminal Type ID	Option
1	0.75	VT / WH	1139	Run/Crank Ignition 1 Voltage	I	—
2	0.5	GN / VT	5906	Driver Seat Blower Motor Control 1	II	—
3	0.75	BK	1550	Ground	I	—
4	—	—	—	Not Occupied	—	—

**M73P Front Seat Cushion Ventilation Blower - Passenger (KA1 & KQV)**

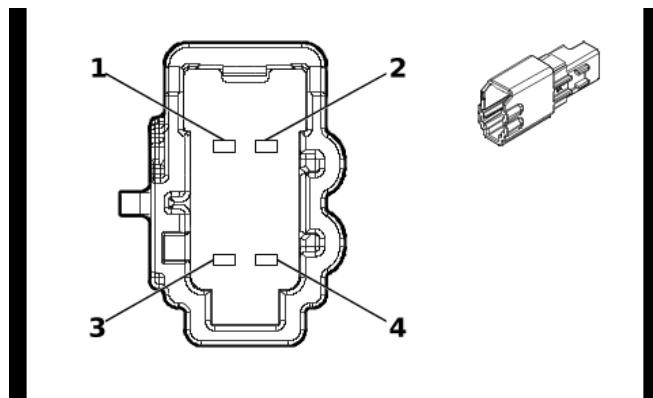

5423974

**Connector Part Information**

Harness Type: Front Seat Wiring Harness - Passenger  
 OEM Connector: 6098-9049  
 Service Connector: Service by Harness - See Part Catalog  
 Description: 4-Way M 1.2 MCON Series( GY)

**Terminal Part Information**

Terminal Type ID	Terminated Lead	Diagnostic Test Probe	Terminal Removal Tool
I	Not required	J-35616-13 (BU)	No Tool Required
II	Not required	J-35616-17 (L-GN)	No Tool Required

**M73P Front Seat Cushion Ventilation Blower - Passenger (KA1 & KQV)**

Pin	Size	Color	Circuit	Function	Terminal Type ID	Option
1	0.75	VT / WH	1139	Run/Crank Ignition 1 Voltage	I	—
2	0.5	VT / WH	5908	Passenger Seat Blower Motor Control 1	II	—
3	0.75	BK	1350	Ground	I	—
4	—	—	—	Not Occupied	—	—

## M74D Front Side Door Window Regulator Motor - Driver

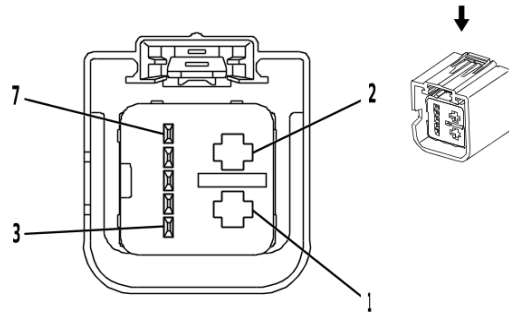

2282932

### Connector Part Information

Harness Type: Front Side Door Door Wiring Harness - Driver  
 OEM Connector: 1-1732115-1  
 Service Connector: Service by Harness - See Part Catalog  
 Description: 7-Way F 0.64, 2.8 Kaizen Timer Series, Sealed( GY)

### Terminal Part Information

Terminal Type ID	Terminated Lead	Diagnostic Test Probe	Terminal Removal Tool
I	Not required	J-35616-4A (PU)	No Tool Required
II	Not required	J-35616-64B (L-BU)	No Tool Required

### M74D Front Side Door Window Regulator Motor - Driver

Pin	Size	Color	Circuit	Function	Terminal Type ID	Option
1	2.5	BK	1550	Ground	I	—
2	2.5	RD / GY	3540	Battery Positive Voltage	I	—
3	0.5	GY / GN	2763	Window Switch Left Front Up Signal	II	—
4	0.5	GN / YE	6134	Body Control Module LIN Bus 3	II	—
5	0.5	GN	2766	Power Window Switch Left Front Express Signal	II	—
6	0.5	GY	745	Left Front Door Ajar Switch Signal	II	—
7	0.5	WH / BN	2764	Window Switch Left Front Down Signal	II	—

**M74LR Rear Side Door Window Regulator Motor - Left**

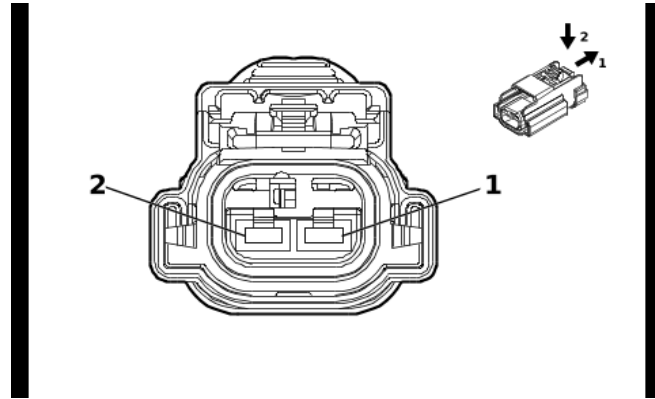

5795169

**Connector Part Information**

Harness Type: Rear Side Door Door Wiring Harness - Left Rear  
 OEM Connector: 35286783  
 Service Connector: Service by Harness - See Part Catalog  
 Description: 2-Way F 2.8 APEX Series, Sealed( BK)

**Terminal Part Information**

Terminal Type ID	Terminated Lead	Diagnostic Test Probe	Terminal Removal Tool
I	Not required	J-35616-35 (VT)	No Tool Required

**M74LR Rear Side Door Window Regulator Motor - Left**

Pin	Size	Color	Circuit	Function	Terminal Type ID	Option
1	2	BU / VT	668	Left Rear Window Motor Up Control	I	—
2	2	YE / BU	669	Left Rear Window Motor Down Control	I	—



**M74P Front Side Door Window Regulator Motor - Passenger - Double Cab / Crew Cab (AED)**

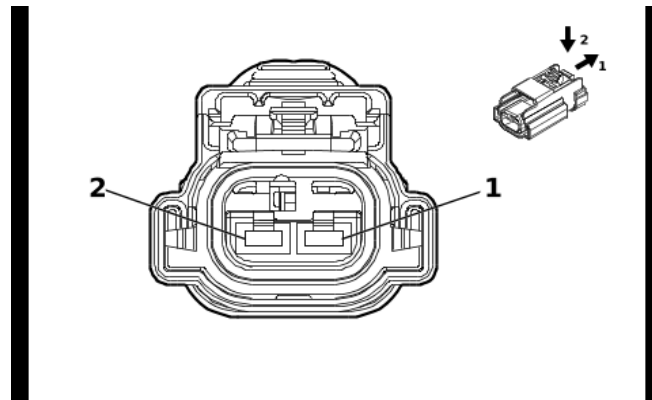

5795169

**Connector Part Information**

Harness Type: Front Side Door Door Wiring Harness - Passenger  
 OEM Connector: 35286783  
 Service Connector: Service by Harness - See Part Catalog  
 Description: 2-Way F 2.8 APEX Series, Sealed( BK)

**Terminal Part Information**

Terminal Type ID	Terminated Lead	Diagnostic Test Probe	Terminal Removal Tool
I	Not required	J-35616-14 (GN)	No Tool Required

**M74P Front Side Door Window Regulator Motor - Passenger - Double Cab / Crew Cab (AED)**

Pin	Size	Color	Circuit	Function	Terminal Type ID	Option
1	0.75	YE / BK	117	Right Front Speaker [-] Control 1	I	—
2	0.75	YE	200	Right Front Speaker 1 [+] Control	I	—

**M74P Front Side Door Window Regulator Motor - Passenger - Double Cab / Crew Cab (AEF)**

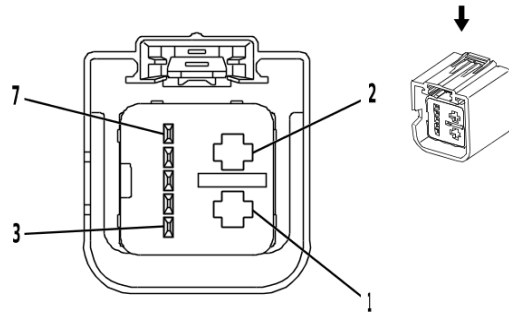

2282932

**Connector Part Information**

Harness Type: Front Side Door Door Wiring Harness - Passenger  
 OEM Connector: 15504732  
 Service Connector: Service by Harness - See Part Catalog  
 Description: 7-Way F 0.64, 2.8 Kaizen Timer Series, Sealed( GY)

**Terminal Part Information**

Terminal Type ID	Terminated Lead	Diagnostic Test Probe	Terminal Removal Tool
I	Not required	J-35616-4A (PU)	No Tool Required
II	Not required	J-35616-64B (L-BU)	No Tool Required

**M74P Front Side Door Window Regulator Motor - Passenger - Double Cab / Crew Cab (AEF)**

Pin	Size	Color	Circuit	Function	Terminal Type ID	Option
1	2.5	BK	1350	Ground	I	—
2	2.5	RD / BN	4240	Battery Positive Voltage	I	—
3	0.5	GN	1184	Window Switch Right Front Up Signal	II	—
4	0.5	GN / YE	6134	Body Control Module LIN Bus 3	II	—
5	0.5	VT / GY	2765	Window Switch Right Front Express Signal	II	—
6	0.5	GY	746	Right Front Door Ajar Switch Signal	II	—
7	0.5	BN	5295	Window Switch Right Front Down Signal	II	—

**M74P Front Side Door Window Regulator Motor - Passenger - Regular Cab (AED)**

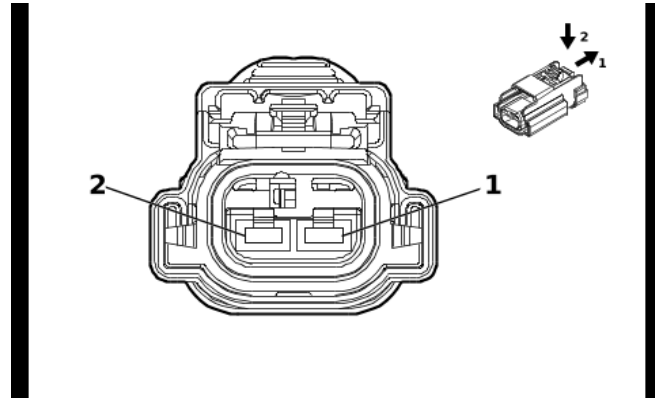

5795169

**Connector Part Information**

Harness Type: Front Side Door Door Wiring Harness - Passenger  
 OEM Connector: 35286783  
 Service Connector: Service by Harness - See Part Catalog  
 Description: 2-Way F 2.8 APEX Series, Sealed( BK)

**Terminal Part Information**

Terminal Type ID	Terminated Lead	Diagnostic Test Probe	Terminal Removal Tool
I	Not required	J-35616-35 (VT)	No Tool Required

**M74P Front Side Door Window Regulator Motor - Passenger - Regular Cab (AED)**

Pin	Size	Color	Circuit	Function	Terminal Type ID	Option
1	2	GN / GY	666	Right Front Window Motor Up Control	I	—
2	2	YE / BU	667	Right Front Window Motor Down Control	I	—

**M74P Front Side Door Window Regulator Motor - Passenger - Regular Cab (AEF)**

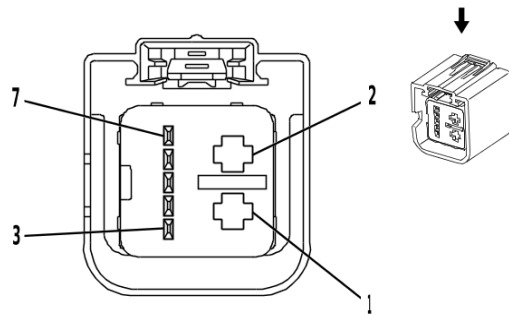

2282932

**Connector Part Information**

Harness Type: Front Side Door Door Wiring Harness - Passenger  
 OEM Connector: 1-1732115-1  
 Service Connector: Service by Harness - See Part Catalog  
 Description: 7-Way F 0.64, 2.8 Kaizen Timer Series, Sealed( GY)

**Terminal Part Information**

Terminal Type ID	Terminated Lead	Diagnostic Test Probe	Terminal Removal Tool
I	Not required	J-35616-4A (PU)	No Tool Required
II	Not required	J-35616-64B (L-BU)	No Tool Required

**M74P Front Side Door Window Regulator Motor - Passenger - Regular Cab (AEF)**

Pin	Size	Color	Circuit	Function	Terminal Type ID	Option
1	2.5	BK	1350	Ground	I	—
2	2.5	RD / BN	4240	Battery Positive Voltage	I	—
3	0.5	GN	1184	Window Switch Right Front Up Signal	II	—
4	0.5	GN / YE	6134	Body Control Module LIN Bus 3	II	—
5	0.5	VT / GY	2765	Window Switch Right Front Express Signal	II	—
6	0.5	GY	746	Right Front Door Ajar Switch Signal	II	—
7	0.5	BN	5295	Window Switch Right Front Down Signal	II	—

**M74RR Rear Side Door Window Regulator Motor - Right**

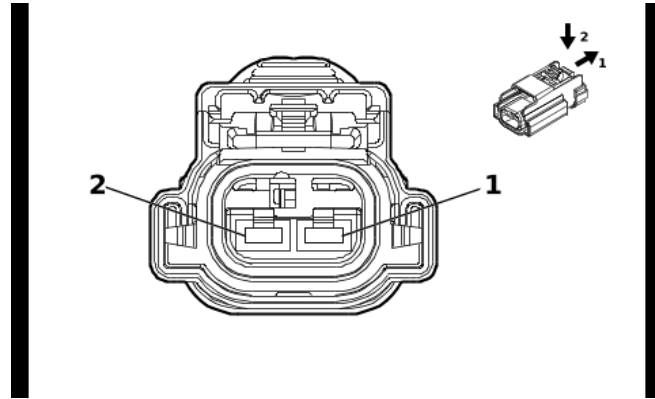

5795169

**Connector Part Information**

Harness Type: Rear Side Door Door Wiring Harness - Right Rear  
 OEM Connector: 35286783  
 Service Connector: Service by Harness - See Part Catalog  
 Description: 2-Way F 2.8 APEX Series, Sealed( BK)

**Terminal Part Information**

Terminal Type ID	Terminated Lead	Diagnostic Test Probe	Terminal Removal Tool
I	Not required	J-35616-35 (VT)	No Tool Required

**M74RR Rear Side Door Window Regulator Motor - Right**

Pin	Size	Color	Circuit	Function	Terminal Type ID	Option
1	2	BU / GY	670	Right Rear Window Motor Up Control	I	—
2	2	GN / BK	671	Right Rear Window Motor Down Control	I	—

**M75 Windshield Wiper Motor**

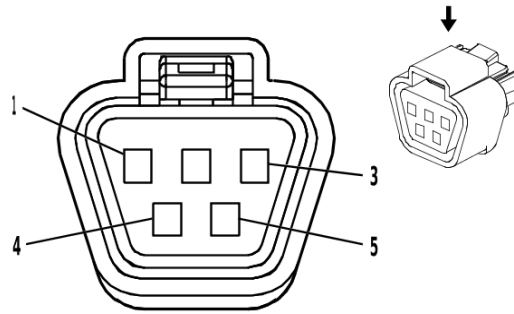

1715213

**Connector Part Information**

Harness Type: Body Wiring Harness  
 OEM Connector: 6189-0587  
 Service Connector: 13587179  
 Description: 5-Way F 090 Series, Sealed( BK)

**Terminal Part Information**

Terminal Type ID	Terminated Lead	Diagnostic Test Probe	Terminal Removal Tool
I	Not required	J-35616-14 (GN)	No Tool Required
II	Not required	J-35616-18 (BK)	No Tool Required

**M75 Windshield Wiper Motor**

Pin	Size	Color	Circuit	Function	Terminal Type ID	Option
1	2	YE / BN	95	Windshield Wiper Motor Low Speed Control	II	—
2	—	—	—	Not Occupied	—	—
3	0.35	BN / GN	196	Windshield Wiper Motor Park Switch Signal	I	—
4	2	WH	92	Windshield Wiper Motor High Speed Control	II	—
5	2	BK	150	Ground	II	—

**M96A Active Grille Air Shutter Actuator 1 (VTI / WMI)**

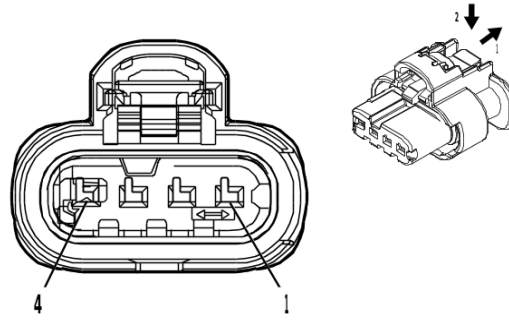

4934614

**Connector Part Information**

Harness Type: Active Grille Air Shutter Wiring Harness  
 OEM Connector: 13514087  
 Service Connector: Service by Harness - See Part Catalog  
 Description: 4-Way F 1.2 MCON-CB Series, Sealed( BK)

**Terminal Part Information**

Terminal Type ID	Terminated Lead	Diagnostic Test Probe	Terminal Removal Tool
I	Not required	J-35616-12 (BU)	No Tool Required

**M96A Active Grille Air Shutter Actuator 1 (VTI / WMI)**

Pin	Size	Color	Circuit	Function	Terminal Type ID	Option
1	0.5	VT / BU	5705	Powertrain Main Relay Control	I	—
2	0.5	GN / VT	4621	Engine Control Module LIN Bus 1	I	—
3	—	—	—	Not Occupied	—	—
4	0.5	BK	450	Ground	I	L3B/ L84/ L87
	0.5	BK	6550	Ground	I	LZ0

**M96B Active Grille Air Shutter Actuator 2 (WMI)**

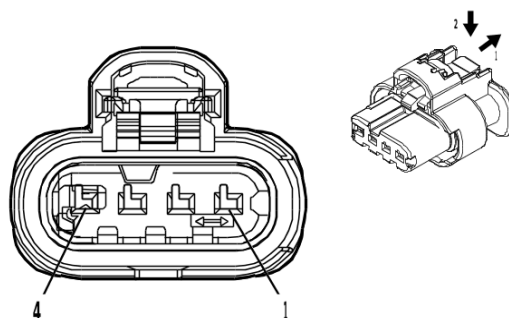

4934614

**Connector Part Information**

Harness Type: Active Grille Air Shutter Jumper Wiring Harness  
 OEM Connector: 13514087  
 Service Connector: Service by Harness - See Part Catalog  
 Description: 4-Way F 1.2 MCON-CB Series, Sealed( BK)

**Terminal Part Information**

Terminal Type ID	Terminated Lead	Diagnostic Test Probe	Terminal Removal Tool
I	Not required	J-35616-12 (BU)	No Tool Required

**M96B Active Grille Air Shutter Actuator 2 (WMI)**

Pin	Size	Color	Circuit	Function	Terminal Type ID	Option
1	0.5	VT / BU	5705	Powertrain Main Relay Control	I	—
2	0.5	GN / VT	4621	Engine Control Module LIN Bus 1	I	—
3	0.5	BK	450	Ground	I	L3B/ L84/ L87
	0.5	BK	6550	Ground	I	LZ0
4	0.5	BK	450	Ground	I	L3B/ L84/ L87
	0.5	BK	6550	Ground	I	LZ0



## M103 Turbocharger Vane Position Actuator

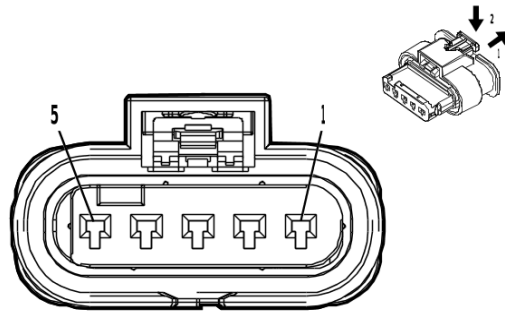

3338689

### Connector Part Information

Harness Type: Engine Wiring Harness  
 OEM Connector: 1-1718806-1  
 Service Connector: 19119351  
 Description: 5-Way F 1.2 MCON-LL Series, Sealed( BK)

### Terminal Part Information

Terminal Type ID	Terminated Lead	Diagnostic Test Probe	Terminal Removal Tool
I	Not required	J-35616-12 (BU)	No Tool Required

### M103 Turbocharger Vane Position Actuator

Pin	Size	Color	Circuit	Function	Terminal Type ID	Option
1	0.75	WH / BN	1313	Variable Geometry Turbocharger Position Sensor Motor Open Control	I	—
2	0.5	VT / YE	5947	Turbocharger Vane Position Sensor Signal	I	—
3	0.5	BK / GN	580	Engine Control Sensors Low Reference 2	I	—
4	0.5	WH / RD	480	Engine Control Vehicle Sensors 5 Volt Reference 1	I	—
5	0.75	GY / BK	1330	Variable Geometry Turbocharger Position Sensor Motor Close Control	I	—

**M104L Parking Brake Actuator - Left**

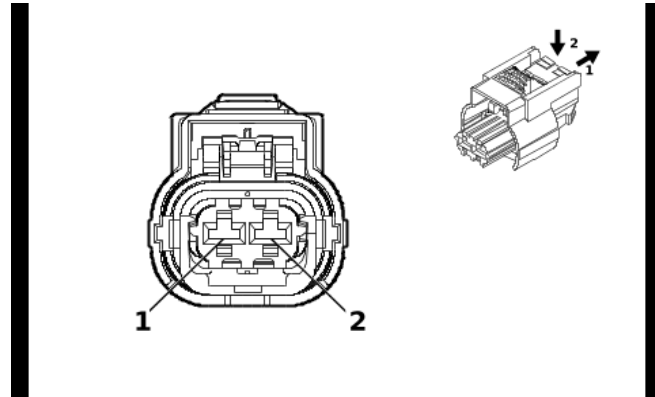

4992524

**Connector Part Information**

Harness Type: Chassis Rear Wiring Harness Extension Harness  
 OEM Connector: 13532979  
 Service Connector: Service by Harness - See Part Catalog  
 Description: 2-Way F 2.8 MCP Series, Sealed( BK)

**Terminal Part Information**

Terminal Type ID	Terminated Lead	Diagnostic Test Probe	Terminal Removal Tool
I	Not required	J-35616-35 (VT)	No Tool Required

**M104L Parking Brake Actuator - Left**

Pin	Size	Color	Circuit	Function	Terminal Type ID	Option
1	2.5	WH	2001	Left Park Brake Motor Apply Control	I	- Z45+ Z45+ G94
2	2.5	GY / BK	4369	Left Park Brake Motor Low Reference	I	- Z45+ Z45+ G94

## M104R Parking Brake Actuator - Right

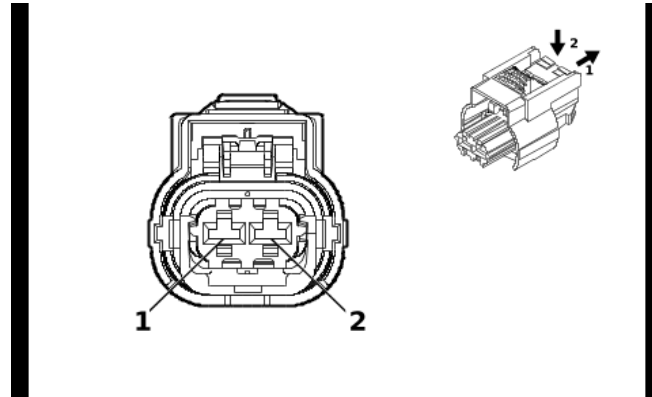

4992524

### Connector Part Information

Harness Type: Chassis Rear Wiring Harness Extension Harness  
 OEM Connector: 13532979  
 Service Connector: Service by Harness - See Part Catalog  
 Description: 2-Way F 2.8 MCP Series, Sealed( BK)

### Terminal Part Information

Terminal Type ID	Terminated Lead	Diagnostic Test Probe	Terminal Removal Tool
I	Not required	J-35616-35 (VT)	No Tool Required

### M104R Parking Brake Actuator - Right

Pin	Size	Color	Circuit	Function	Terminal Type ID	Option
1	2.5	GN / VT	1988	Right Park Brake Motor Apply Control	I	- Z45+ Z45+ G94
2	2.5	GY	4368	Right Park Brake Motor Low Reference	I	- Z45+ Z45+ G94

**M106V Exhaust Control Valve Actuator - Variable (L87)**

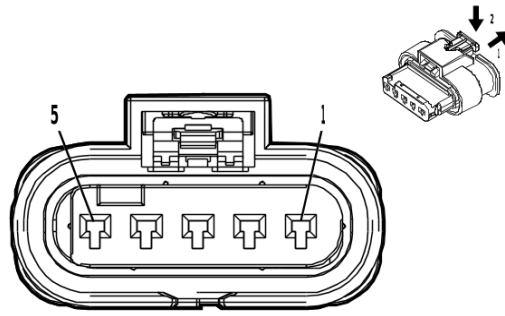

3338689

**Connector Part Information**

Harness Type: Chassis Wiring Harness  
 OEM Connector: 1-1718806-1  
 Service Connector: 19119351  
 Description: 5-Way F 1.2 MCON-LL Series, Sealed( BK)

**Terminal Part Information**

Terminal Type ID	Terminated Lead	Diagnostic Test Probe	Terminal Removal Tool
I	Not required	J-35616-12 (BU)	No Tool Required

**M106V Exhaust Control Valve Actuator - Variable (L87)**

Pin	Size	Color	Circuit	Function	Terminal Type ID	Option
1	0.75	BK	1650	Ground	I	—
2	0.5	BN / GN	4305	Exhaust Flow Control Valve 1	I	—
3	0.5	VT / WH	639	Run/Crank Ignition 1 Voltage	I	—
4	0.5	BU / WH	4306	Exhaust Flow Control Valve 1 - Cylinder Deactivation Feedback Signal	I	—
5	—	—	—	Not Occupied	—	—

## M122 Exhaust Pressure Regulator Valve

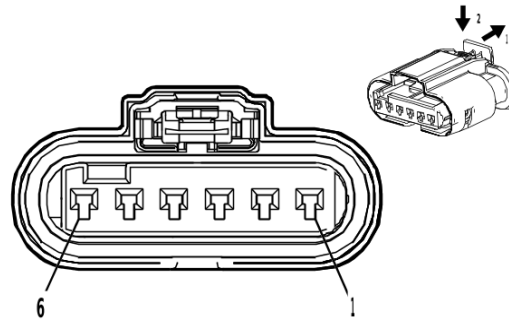

3960142

### Connector Part Information

Harness Type: Chassis Wiring Harness  
 OEM Connector: 34900-6119  
 Service Connector: 85005020  
 Description: 6-Way F 1.2 MCON-LL Series, Sealed( BK)

### Terminal Part Information

Terminal Type ID	Terminated Lead	Diagnostic Test Probe	Terminal Removal Tool
I	Not required	J-35616-16 (L-GN)	No Tool Required

### M122 Exhaust Pressure Regulator Valve

Pin	Size	Color	Circuit	Function	Terminal Type ID	Option
1	0.75	YE / BN	1420	Exhaust Restrictor Motor Open Control	I	—
2	0.75	BN	1421	Exhaust Restrictor Motor Closed Control	I	—
3	0.5	BK / YE	548	Engine Control Sensors Low Reference 1	I	—
4	0.5	BN / GN	4305	Exhaust Flow Control Valve 1	I	—
5	0.5	BU / RD	460	Engine Control Sensors 5 Volt Reference 1	I	—
6	—	—	—	Not Occupied	—	—

**M123 Transmission Park Valve Lock Solenoid Actuator (MHS / MQC)**

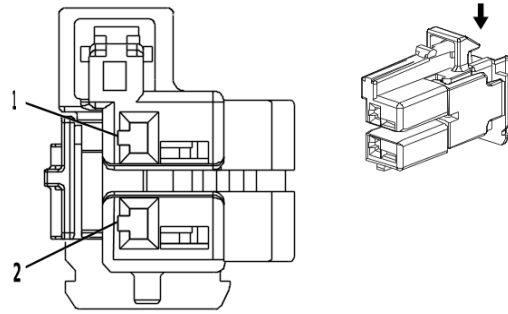

4364736

**Connector Part Information**

Harness Type: Automatic Transmission Wiring Harness - Control  
 OEM Connector: 2289523-2  
 Service Connector: Service by Harness - See Part Catalog  
 Description: 2-Way F 1.2 MCON Series( BU)

**Terminal Part Information**

Terminal Type ID	Terminated Lead	Diagnostic Test Probe	Terminal Removal Tool
I	Not required	J-35616-12 (BU)	No Tool Required

**M123 Transmission Park Valve Lock Solenoid Actuator (MHS / MQC)**

Pin	Size	Color	Circuit	Function	Terminal Type ID	Option
1	0.5	BN	6387	Transmission High Side Driver 1 Control	I	—
2	0.5	OG	2159	Park Inhibit Solenoid Assembly Control	I	—

**M125 Pickup Box Endgate Power Assist Actuator**

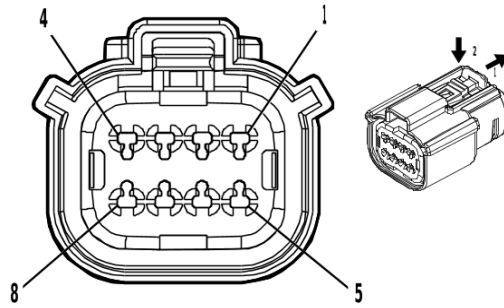

4846407

**Connector Part Information**

Harness Type: Endgate Wiring Harness  
 OEM Connector: 33472-4806  
 Service Connector: Service by Harness - See Part Catalog  
 Description: 8-Way F 1.5 MX Series, Sealed( BK)

**Terminal Part Information**

Terminal Type ID	Terminated Lead	Diagnostic Test Probe	Terminal Removal Tool
I	Not required	J-35616-2A (GY)	No Tool Required

**M125 Pickup Box Endgate Power Assist Actuator**

Pin	Size	Color	Circuit	Function	Terminal Type ID	Option
1	1	BN / WH	4690	Rear Closure Open/Close Motor Close Control	I	—
2	0.5	GN	1577	Rear Closure Clutch Control	I	—
3	0.5	BU / BK	1590	Rear Closure Clutch Low Return	I	—
4	0.5	BN / RD	4683	Rear Closure Position Sensor Voltage Reference	I	—
5	1	WH	4689	Rear Closure Open/Close Motor Open Control	I	—
6	0.5	BN / YE	4686	Rear Closure Position Sensor Signal 2	I	—
7	0.5	BK / GN	4687	Rear Closure Position Sensor Low Reference	I	—
8	0.5	BU / WH	4685	Rear Closure Position Sensor Signal 1	I	—

## M128 Turbocharger Wastegate Actuator

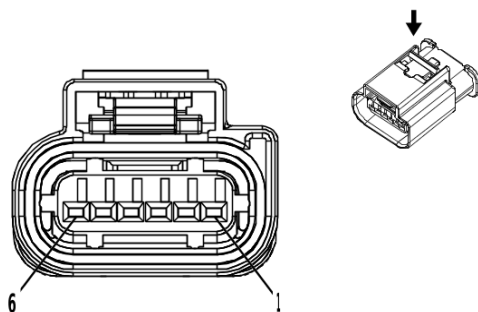

3747579

### Connector Part Information

Harness Type: Engine Wiring Harness

OEM Connector: 2272975-5

Service Connector: 19352911

Description: 6-Way F 1.2 MCON Series, Sealed( BK)

### Terminal Part Information

Terminal Type ID	Terminated Lead	Diagnostic Test Probe	Terminal Removal Tool
I	Not required	J-35616-12 (BU)	No Tool Required

### M128 Turbocharger Wastegate Actuator

Pin	Size	Color	Circuit	Function	Terminal Type ID	Option
1	0.5	BK / YE	548	Engine Control Sensors Low Reference 1	I	—
2	0.5	WH	2590	Turbocharger Wastegate Motor Feedback Signal	I	—
3	0.5	BU / RD	460	Engine Control Sensors 5 Volt Reference 1	I	—
4	0.75	WH / BU	2592	Turbocharger Wastegate Motor Close Control	I	—
5	0.75	WH / BN	2591	Turbocharger Wastegate Motor Open Control	I	—
6	—	—	—	Not Occupied	—	—



## M129A Intake Camshaft Profile Actuator 1

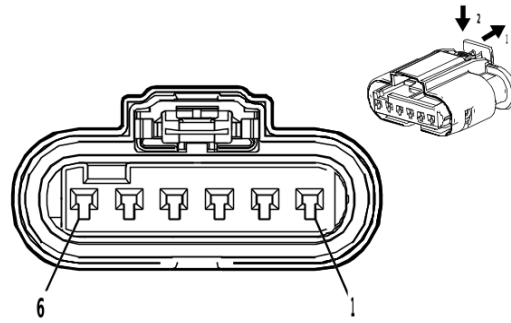

3960142

### Connector Part Information

Harness Type: Engine Wiring Harness  
 OEM Connector: 34900-6219  
 Service Connector: 85005020  
 Description: 6-Way F 1.2 MCON-LL Series, Sealed( BK)

### Terminal Part Information

Terminal Type ID	Terminated Lead	Diagnostic Test Probe	Terminal Removal Tool
I	Not required	J-35616-12 (BU)	No Tool Required

### M129A Intake Camshaft Profile Actuator 1

Pin	Size	Color	Circuit	Function	Terminal Type ID	Option
1	0.5	VT / GY	3615	Intake Camshaft Profile Actuator 1 Control A	I	—
2	0.5	BU / WH	3589	Intake Camshaft Profile Actuator 1 Position Sensor Signal	I	—
3	0.5	BK / YE	548	Engine Control Sensors Low Reference 1	I	—
4	0.5	BU / RD	460	Engine Control Sensors 5 Volt Reference 1	I	—
5	0.5	VT / BU	5293	Powertrain Main Relay Fused Supply Voltage 4	I	—
6	0.5	GN / BK	3616	Intake Camshaft Profile Actuator 1 Control B	I	—

**M129B Intake Camshaft Profile Actuator 2**

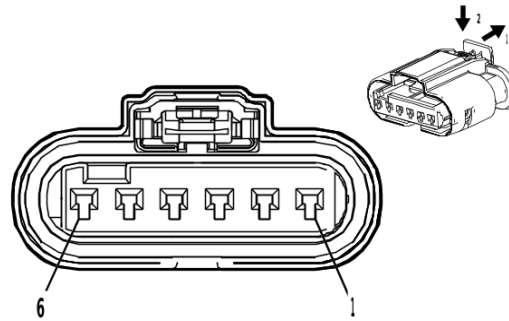

3960142

**Connector Part Information**

Harness Type: Engine Wiring Harness  
 OEM Connector: 34900-6219  
 Service Connector: 85005020  
 Description: 6-Way F 1.2 MCON-LL Series, Sealed( BK)

**Terminal Part Information**

Terminal Type ID	Terminated Lead	Diagnostic Test Probe	Terminal Removal Tool
I	Not required	J-35616-12 (BU)	No Tool Required

**M129B Intake Camshaft Profile Actuator 2**

Pin	Size	Color	Circuit	Function	Terminal Type ID	Option
1	0.5	GN	3585	Intake Camshaft Profile Actuator 2 Control A	I	—
2	0.5	GN / WH	3592	Intake Camshaft Profile Actuator 2 Position Sensor Signal	I	—
3	0.5	BK / YE	548	Engine Control Sensors Low Reference 1	I	—
4	0.5	BU / RD	460	Engine Control Sensors 5 Volt Reference 1	I	—
5	0.5	VT / BU	5293	Powertrain Main Relay Fused Supply Voltage 4	I	—
6	0.5	BU	3584	Intake Camshaft Profile Actuator 2 Control B	I	—

### M129C Intake Camshaft Profile Actuator 3

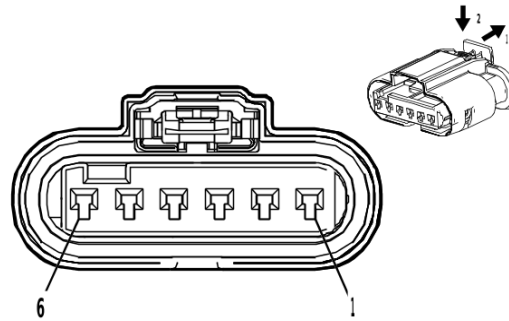

3960142

#### Connector Part Information

Harness Type: Engine Wiring Harness  
 OEM Connector: 34900-6219  
 Service Connector: 85005020  
 Description: 6-Way F 1.2 MCON-LL Series, Sealed( BK)

#### Terminal Part Information

Terminal Type ID	Terminated Lead	Diagnostic Test Probe	Terminal Removal Tool
I	Not required	J-35616-12 (BU)	No Tool Required

#### M129C Intake Camshaft Profile Actuator 3

Pin	Size	Color	Circuit	Function	Terminal Type ID	Option
1	0.5	YE / BU	3587	Intake Camshaft Profile Actuator 3 Control A	I	—
2	0.5	BK / GN	3593	Intake Camshaft Profile Actuator 3 Position Sensor Signal	I	—
3	0.5	BK / YE	548	Engine Control Sensors Low Reference 1	I	—
4	0.5	BU / RD	460	Engine Control Sensors 5 Volt Reference 1	I	—
5	0.5	VT / BU	5293	Powertrain Main Relay Fused Supply Voltage 4	I	—
6	0.5	GY	3586	Intake Camshaft Profile Actuator 3 Control B	I	—

**M129D Intake Camshaft Profile Actuator 4**

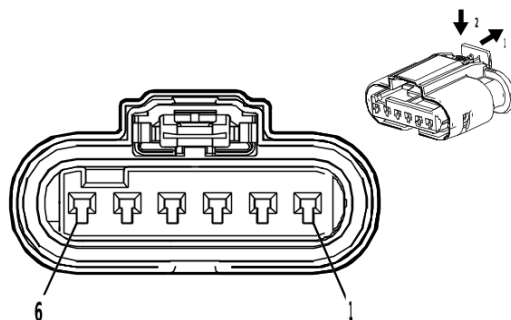

3960142

**Connector Part Information**

Harness Type: Engine Wiring Harness  
 OEM Connector: 34900-6219  
 Service Connector: 85005020  
 Description: 6-Way F 1.2 MCON-LL Series, Sealed( BK)

**Terminal Part Information**

Terminal Type ID	Terminated Lead	Diagnostic Test Probe	Terminal Removal Tool
I	Not required	J-35616-12 (BU)	No Tool Required

**M129D Intake Camshaft Profile Actuator 4**

Pin	Size	Color	Circuit	Function	Terminal Type ID	Option
1	0.5	GN / YE	1402	Intake Camshaft Profile Actuator 4 Control A	I	—
2	0.5	YE / BN	1702	Intake Camshaft Profile Actuator 4 Position Sensor Signal	I	—
3	0.5	BK / YE	548	Engine Control Sensors Low Reference 1	I	—
4	0.5	BU / RD	460	Engine Control Sensors 5 Volt Reference 1	I	—
5	0.5	VT / BU	5293	Powertrain Main Relay Fused Supply Voltage 4	I	—
6	0.5	GY / YE	1502	Intake Camshaft Profile Actuator 4 Control B	I	—

## M130B Exhaust Camshaft Profile Actuator 2

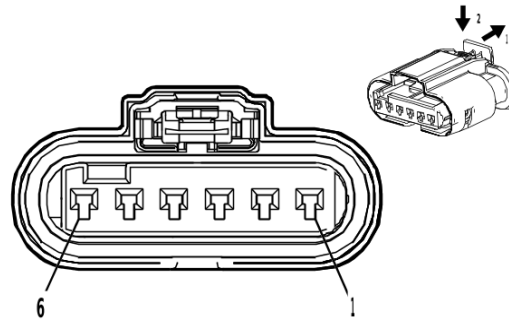

3960142

### Connector Part Information

Harness Type: Engine Wiring Harness  
 OEM Connector: 34900-6219  
 Service Connector: 85005020  
 Description: 6-Way F 1.2 MCON-LL Series, Sealed( BK)

### Terminal Part Information

Terminal Type ID	Terminated Lead	Diagnostic Test Probe	Terminal Removal Tool
I	Not required	J-35616-12 (BU)	No Tool Required

### M130B Exhaust Camshaft Profile Actuator 2

Pin	Size	Color	Circuit	Function	Terminal Type ID	Option
1	0.5	YE / VT	6265	Exhaust Camshaft Profile Actuator 2 Control B	I	—
2	0.5	GN / BK	6266	Exhaust Camshaft Profile Actuator 2 Position Sensor Signal	I	—
3	0.5	BK / YE	548	Engine Control Sensors Low Reference 1	I	—
4	0.5	BU / RD	460	Engine Control Sensors 5 Volt Reference 1	I	—
5	0.5	VT / BU	5293	Powertrain Main Relay Fused Supply Voltage 4	I	—
6	0.5	VT / BK	6264	Exhaust Camshaft Profile Actuator 2 Control A	I	—

**M151L Pickup Box Endgate Cinch Latch Actuator - Left**

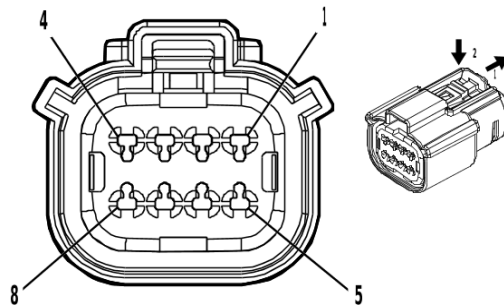

4846407

**Connector Part Information**

Harness Type: Endgate Wiring Harness  
 OEM Connector: 33472-4806  
 Service Connector: Service by Harness - See Part Catalog  
 Description: 8-Way F 1.5 MX Series, Sealed( BK)

**Terminal Part Information**

Terminal Type ID	Terminated Lead	Diagnostic Test Probe	Terminal Removal Tool
I	Not required	J-35616-2A (GY)	No Tool Required

**M151L Pickup Box Endgate Cinch Latch Actuator - Left**

Pin	Size	Color	Circuit	Function	Terminal Type ID	Option
1	—	—	—	Not Occupied	—	—
2	0.5	BN / GY	10281	Rear Closure Latch Secondary Status Signal	I	—
3	0.5	GY / VT	4678	Rear Closure Latch Unlatch Status	I	—
4	0.5	BK / VT	4656	Rear Closure Object Sensor Low Reference	I	—
5	1	BN	4681	Rear Closure Cinch Latch Motor Cinch Control	I	—
6	1	BU / GY	4682	Rear Closure Cinch Latch Motor Release Control	I	—
7	0.5	WH / GN	8084	Rear Closure Latch Neutral Status	I	—
8	0.5	YE / BK	8085	Rear Closure Latch Primary Status	I	—

**M151R Pickup Box Endgate Cinch Latch Actuator - Right**

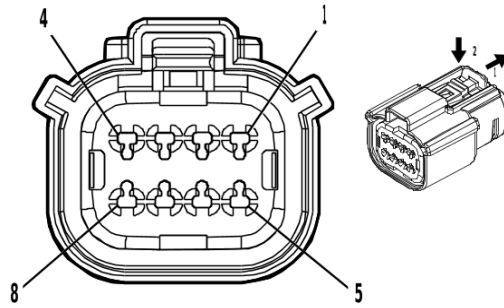

4846407

**Connector Part Information**

Harness Type: Endgate Wiring Harness  
 OEM Connector: 33472-4806  
 Service Connector: Service by Harness - See Part Catalog  
 Description: 8-Way F 1.5 MX Series, Sealed( BK)

**Terminal Part Information**

Terminal Type ID	Terminated Lead	Diagnostic Test Probe	Terminal Removal Tool
I	Not required	J-35616-2A (GY)	No Tool Required

**M151R Pickup Box Endgate Cinch Latch Actuator - Right**

Pin	Size	Color	Circuit	Function	Terminal Type ID	Option
1	0.5	GY / BK	1575	Rear Closure Sensor Low Reference 2	I	—
2	0.5	BN	7736	Rear Closure Latch 2 Unlatch Status Signal	I	—
3	0.5	VT / WH	10284	Rear Closure Latch 2 Secondary Status Signal	I	—
4	—	—	—	Not Occupied	—	—
5	0.5	GN / BU	10283	Rear Closure Latch 2 Primary Status Signal	I	—
6	0.5	BU / BN	10282	Rear Closure Latch 2 Neutral Status Signal	I	—
7	1	GN	1499	Rear Closure Cinch Latch Motor 2 Cinch Control	I	—
8	1	BU	1509	Rear Closure Cinch Latch Motor 2 Release Control	I	—

P13 Horn

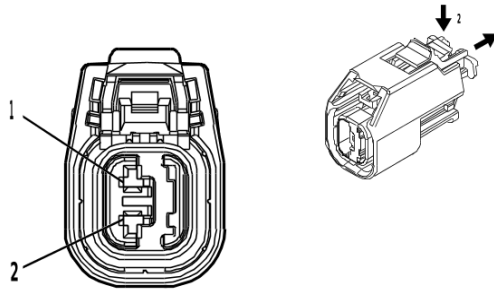

4889830

**Connector Part Information**

Harness Type: Body Wiring Harness  
 OEM Connector: 33164011  
 Service Connector: 86802964  
 Description: 2-Way F 1.5 OCS Series, Sealed( BK)

**Terminal Part Information**

Terminal Type ID	Terminated Lead	Diagnostic Test Probe	Terminal Removal Tool
I	Not required	J-35616-2A (GY)	No Tool Required

**P13 Horn**

Pin	Size	Color	Circuit	Function	Terminal Type ID	Option
1	0.75	BK	650	Ground	I	—
2	0.75	BN / GY	29	Horn Control	I	—



## P16 Instrument Panel Cluster Control Module X1

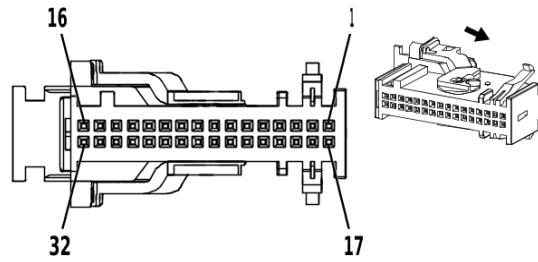

627214

### Connector Part Information

Harness Type: Instrument Panel Wiring Harness  
 OEM Connector: 2-2236674-1  
 Service Connector: 13511333  
 Description: 32-Way F 0.64 Micro-Quadlock Series( GY)

### Terminal Part Information

Terminal Type ID	Terminated Lead	Diagnostic Test Probe	Terminal Removal Tool
I	19300632	J-35616-64B (L-BU)	J-38125-215A
II	Service by Cable	No Tool Required	No Tool Required

### P16 Instrument Panel Cluster Control Module X1

Pin	Size	Color	Circuit	Function	Terminal Type ID	Option
1	0.35	WH	7216	Ethernet Bus 7 [-]	II	UDV
2 - 6	—	—	—	Not Occupied	—	—
7	0.5	RD / WH	1340	Battery Positive Voltage	I	—
8	0.35	VT / BK	339	Run/Crank Ignition 1 Voltage	I	—
9 - 10	—	—	—	Not Occupied	—	—
11	0.35	GY / BK	4787	Day Night LED Control	I	—
12	0.35	GY / YE	3885	Forward Collision Alert LED Control	I	—
13	0.35	BU / WH	4985	AUTOSAR CAN Bus [+] 5 Serial Data	I	—
14	0.35	BU / YE	4984	AUTOSAR CAN Bus [-] 5 Serial Data	I	—
15 - 16	—	—	—	Not Occupied	—	—
17	0.35	GN	7217	Ethernet Bus 7 [+]	II	UDV
18	—	—	—	Not Occupied	—	—
19	0.5	BK	851	Signal Ground	I	—
20	0.5	GN / BK	3894	Instrument Panel Cluster Control Module LIN Bus 1	I	—
21 - 28	—	—	—	Not Occupied	—	—
29	0.35	BU / WH	4985	AUTOSAR CAN Bus [+] 5 Serial Data	I	—
30	0.35	BU / YE	4984	AUTOSAR CAN Bus [-] 5 Serial Data	I	—
31	—	—	—	Not Occupied	—	—
32	0.35	GN / BN	507	Wait To Start Indicator Control	I	—

**P16 Instrument Panel Cluster Control Module X2**

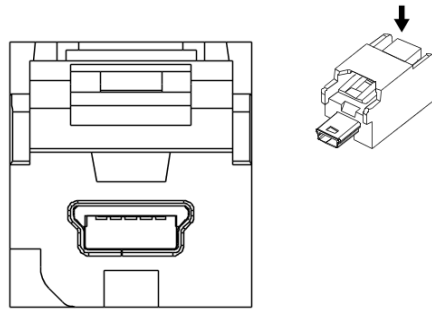

3214018

**Connector Part Information**

Harness Type: Instrument Panel Wiring Harness USB  
 OEM Connector: 13893437  
 Service Connector: Service by Cable Assembly — See Part Catalog  
 Description: 5-Way M 2.0 Mini-B USB Type( GY)

**Terminal Part Information**

Terminal Type ID	Terminated Lead	Diagnostic Test Probe	Terminal Removal Tool
I	Not required	No Tool Required	No Tool Required

**P16 Instrument Panel Cluster Control Module X2**

Pin	Size	Color	Circuit	Function	Terminal Type ID	Option
—	—	USB	—	USB Serial Data	I	—

**P19AFC Front Floor Speaker - Console (UQA / UQS)**

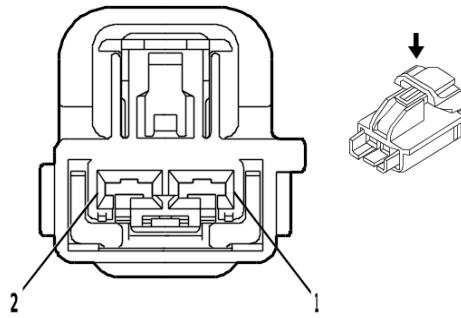

1803142

**Connector Part Information**

Harness Type: Body Wiring Harness  
 OEM Connector: 7283-6445-40  
 Service Connector: 19367562  
 Description: 2-Way F Kaizen Series( L-GY)

**Terminal Part Information**

Terminal Type ID	Terminated Lead	Diagnostic Test Probe	Terminal Removal Tool
I	Not required	J-35616-4A (PU)	No Tool Required

**P19AFC Front Floor Speaker - Console (UQA / UQS)**

Pin	Size	Color	Circuit	Function	Terminal Type ID	Option
1	2.5	GN / BK	1794	Left/Rear Subwoofer [-] Control	I	—
2	2.5	BU / GY	346	Left/Rear Subwoofer [+] Control	I	—

**P19AG Radio Front Side Door Speaker - Left**

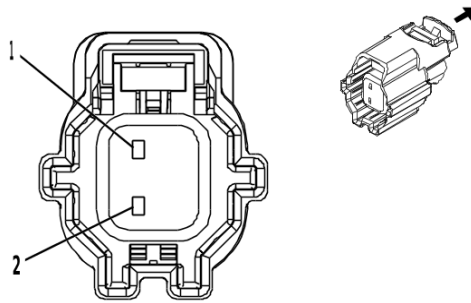

4223204

**Connector Part Information**

Harness Type: Front Side Door Door Wiring Harness - Driver  
 OEM Connector: 34062-0044  
 Service Connector: Service by Harness - See Part Catalog  
 Description: 2-Way F 1.5 MX Series, Sealed( BK)

**Terminal Part Information**

Terminal Type ID	Terminated Lead	Diagnostic Test Probe	Terminal Removal Tool
I	Not required	J-35616-2A (GY)	No Tool Required

**P19AG Radio Front Side Door Speaker - Left**

Pin	Size	Color	Circuit	Function	Terminal Type ID	Option
1	0.75	BN / BU	118	Left Front Speaker [-] Control 1	I	—
2	0.75	BU	201	Left Front Speaker 1 [+] Control	I	—

**P19AH Radio Front Side Door Speaker - Right - Double Cab / Crew Cab**

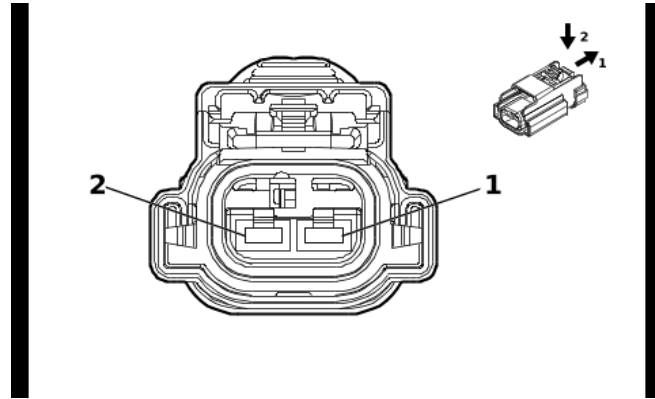

5795169

**Connector Part Information**

Harness Type: Front Side Door Door Wiring Harness - Passenger  
 OEM Connector: 35286783  
 Service Connector: Service by Harness - See Part Catalog  
 Description: 2-Way F 2.8 APEX Series, Sealed( BK)

**Terminal Part Information**

Terminal Type ID	Terminated Lead	Diagnostic Test Probe	Terminal Removal Tool
I	Not required	J-35616-35 (VT)	No Tool Required

**P19AH Radio Front Side Door Speaker - Right - Double Cab / Crew Cab**

Pin	Size	Color	Circuit	Function	Terminal Type ID	Option
1	2	GN / GY	666	Right Front Window Motor Up Control	I	—
2	2	YE / BU	667	Right Front Window Motor Down Control	I	—

**P19AH Radio Front Side Door Speaker - Right - Regular Cab**

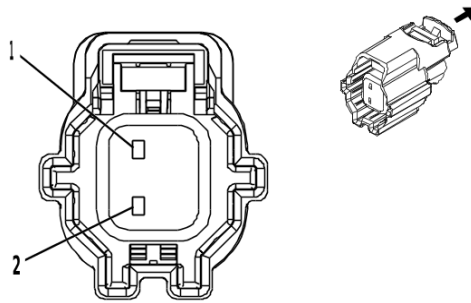

4223204

**Connector Part Information**

Harness Type: Front Side Door Door Wiring Harness - Passenger  
 OEM Connector: 34062-0044  
 Service Connector: Service by Harness - See Part Catalog  
 Description: 2-Way F 1.5 MX Series, Sealed( BK)

**Terminal Part Information**

Terminal Type ID	Terminated Lead	Diagnostic Test Probe	Terminal Removal Tool
I	Not required	J-35616-2A (GY)	No Tool Required

**P19AH Radio Front Side Door Speaker - Right - Regular Cab**

Pin	Size	Color	Circuit	Function	Terminal Type ID	Option
1	0.75	YE / BK	117	Right Front Speaker [-] Control 1	I	—
2	0.75	YE	200	Right Front Speaker 1 [+] Control	I	—

**P19AL Radio Rear Side Door Speaker - Left**

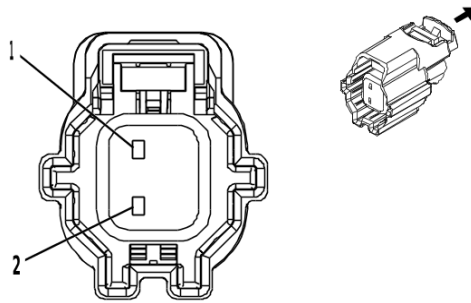

4223204

**Connector Part Information**

Harness Type: Rear Side Door Door Wiring Harness - Left Rear  
 OEM Connector: 34062-0044  
 Service Connector: Service by Harness - See Part Catalog  
 Description: 2-Way F 1.5 MX Series, Sealed( BK)

**Terminal Part Information**

Terminal Type ID	Terminated Lead	Diagnostic Test Probe	Terminal Removal Tool
I	Not required	J-35616-2A (GY)	No Tool Required

**P19AL Radio Rear Side Door Speaker - Left**

Pin	Size	Color	Circuit	Function	Terminal Type ID	Option
1	0.75	GN / BK	116	Left Rear Speaker [-] Control	I	—
2	0.75	GN	199	Left Rear Speaker [+] Control	I	—

**P19AM Radio Rear Side Door Speaker - Right**

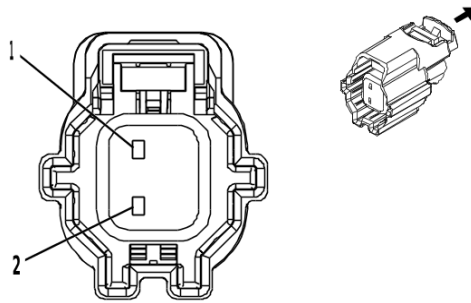

4223204

**Connector Part Information**

Harness Type: Rear Side Door Door Wiring Harness - Right Rear  
 OEM Connector: 34062-0044  
 Service Connector: Service by Harness - See Part Catalog  
 Description: 2-Way F 1.5 MX Series, Sealed( BK)

**Terminal Part Information**

Terminal Type ID	Terminated Lead	Diagnostic Test Probe	Terminal Removal Tool
I	Not required	J-35616-2A (GY)	No Tool Required

**P19AM Radio Rear Side Door Speaker - Right**

Pin	Size	Color	Circuit	Function	Terminal Type ID	Option
1	0.75	BU / BK	115	Right Rear Speaker [-] Control	I	—
2	0.75	WH	46	Right Rear Speaker [+] Control	I	—



**P19J Radio Front Speaker - Instrument Panel Left (UQA)**

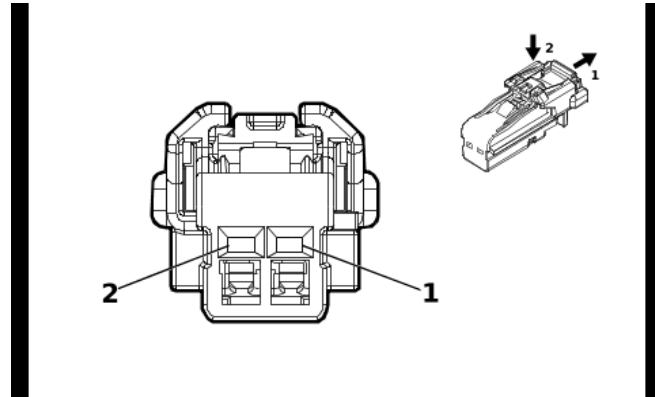

4115691

**Connector Part Information**

Harness Type: Instrument Panel Wiring Harness  
 OEM Connector: 6098-8988  
 Service Connector: 87816612  
 Description: 2-Way F 1.2 MCON Series( BK)

**Terminal Part Information**

Terminal Type ID	Terminated Lead	Diagnostic Test Probe	Terminal Removal Tool
I	Not required	J-35616-16 (L-GN)	No Tool Required

**P19J Radio Front Speaker - Instrument Panel Left (UQA)**

Pin	Size	Color	Circuit	Function	Terminal Type ID	Option
1	0.75	BU / BN	1957	Left Front Midrange Speaker [-] Control	I	—
2	0.75	BU / VT	1857	Left Front Midrange Speaker [+] Control	I	—

**P19W Radio Front Speaker - Instrument Panel Right**

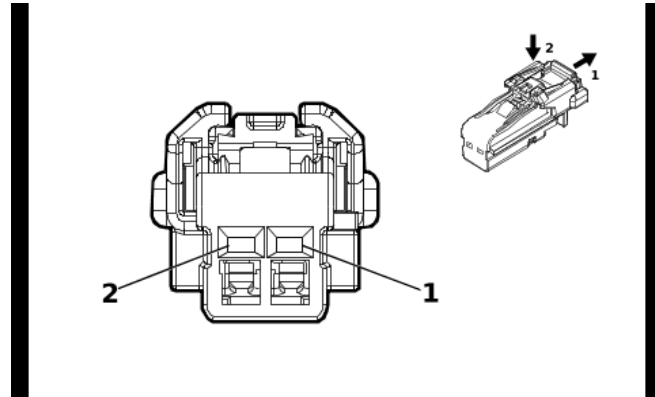

4115691

**Connector Part Information**

Harness Type: Instrument Panel Wiring Harness  
 OEM Connector: 6098-8988  
 Service Connector: 87816612  
 Description: 2-Way F 1.2 MCON Series( BK)

**Terminal Part Information**

Terminal Type ID	Terminated Lead	Diagnostic Test Probe	Terminal Removal Tool
I	Not required	J-35616-16 (L-GN)	No Tool Required
II	Not required	No Tool Required	No Tool Required

**P19W Radio Front Speaker - Instrument Panel Right**

Pin	Size	Color	Circuit	Function	Terminal Type ID	Option
1	— 0.75	BN / BK	1953	Right Front Midrange Speaker [-] Control	II	—
		YE / BK	117	Right Front Speaker [-] Control 1	I	—
2	— 0.75	WH / YE	1853	Right Front Midrange Speaker [+] Control	II	—
		YE	200	Right Front Speaker 1 [+] Control	I	—

## P29 Head-Up Display X1

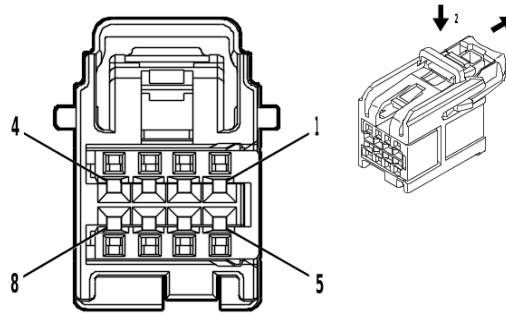

4935776

### Connector Part Information

Harness Type: Instrument Panel Wiring Harness  
 OEM Connector: 15526972  
 Service Connector: 19370429  
 Description: 8-Way F 0.64 OCS Series( BK)

### Terminal Part Information

Terminal Type ID	Terminated Lead	Diagnostic Test Probe	Terminal Removal Tool
I	Not required	J-35616-64B (L-BU)	No Tool Required

### P29 Head-Up Display X1

Pin	Size	Color	Circuit	Function	Terminal Type ID	Option
1	0.35	GN / BK	3894	Instrument Panel Cluster Control Module LIN Bus 1	I	—
2	—	—	—	Not Occupied	—	—
3	0.35	YE / WH	622	Head-Up Display Switch Signal	I	—
4	0.5	BK / WH	851	Signal Ground	I	—
5	—	—	—	Not Occupied	—	—
6	0.5	RD / WH	1340	Battery Positive Voltage	I	—
7	—	—	—	Not Occupied	—	—
8	0.35	BK / GN	5699	Head-Up Display Switch Low Reference	I	—

**P29 Head-Up Display X2**

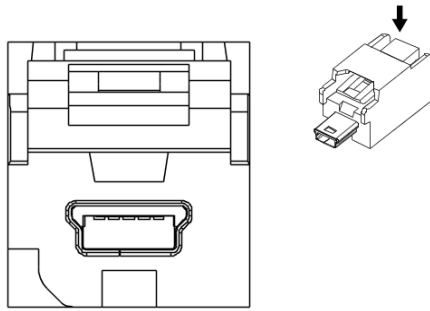

3214018

**Connector Part Information**

Harness Type: Instrument Panel Wiring Harness USB  
 OEM Connector: 13871470  
 Service Connector: Service by Cable Assembly — See Part Catalog  
 Description: 5-Way M 2.0 Mini-B USB Type( GY)

**Terminal Part Information**

Terminal Type ID	Terminated Lead	Diagnostic Test Probe	Terminal Removal Tool
I	Not required	No Tool Required	No Tool Required

**P29 Head-Up Display X2**

Pin	Size	Color	Circuit	Function	Terminal Type ID	Option
—	—	USB	—	USB Serial Data	I	—

**P43 Forward Collision Alert Display ((UEU / UHX) - UV6)**

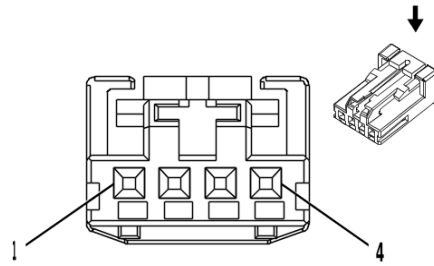

2717162

**Connector Part Information**

Harness Type: Instrument Panel Wiring Harness  
 OEM Connector: 1-936119-1  
 Service Connector: 19367524  
 Description: 4-Way F 0.64 Micro-Quadlock Series( BK)

**Terminal Part Information**

Terminal Type ID	Terminated Lead	Diagnostic Test Probe	Terminal Removal Tool
I	Not required	J-35616-64B (L-BU)	No Tool Required

**P43 Forward Collision Alert Display ((UEU / UHX) - UV6)**

Pin	Size	Color	Circuit	Function	Terminal Type ID	Option
1	0.35	VT / BK	339	Run/Crank Ignition 1 Voltage	I	—
2	0.35	GY / YE	3885	Forward Collision Alert LED Control	I	—
3	0.35	GY / BK	4787	Day Night LED Control	I	—
4	0.35	BK / WH	851	Signal Ground	I	—

**P45L Front Seat Lane Departure Warning Actuator - Left**

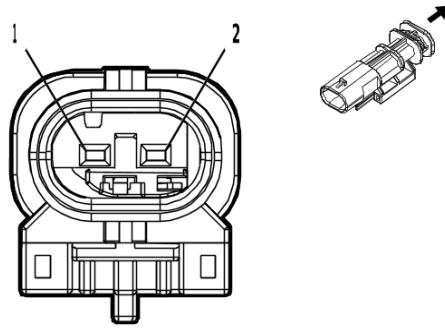

4569729

**Connector Part Information**

Harness Type: Front Seat Wiring Harness - Driver  
 OEM Connector: 34899-2080  
 Service Connector: Service by Harness - See Part Catalog  
 Description: 2-Way M 1.2 MCON Series, Sealed( BK)

**Terminal Part Information**

Terminal Type ID	Terminated Lead	Diagnostic Test Probe	Terminal Removal Tool
I	Not required	J-35616-13 (BU)	No Tool Required

**P45L Front Seat Lane Departure Warning Actuator - Left**

Pin	Size	Color	Circuit	Function	Terminal Type ID	Option
1	0.5	BK	1550	Ground	I	—
2	0.35	YE / BN	3037	Driver Seat Left Rear Haptic Movement Motor Control	I	—

**P45R Front Seat Lane Departure Warning Actuator - Right**

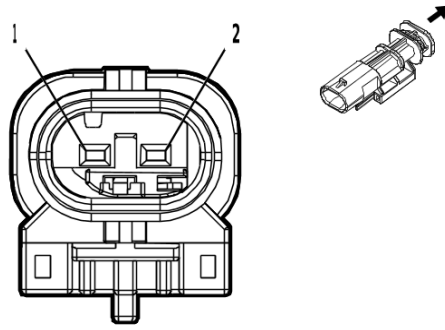

4569729

**Connector Part Information**

Harness Type: Front Seat Wiring Harness - Driver  
 OEM Connector: 34899-2080  
 Service Connector: Service by Harness - See Part Catalog  
 Description: 2-Way M 1.2 MCON Series, Sealed( BK)

**Terminal Part Information**

Terminal Type ID	Terminated Lead	Diagnostic Test Probe	Terminal Removal Tool
I	Not required	J-35616-13 (BU)	No Tool Required

**P45R Front Seat Lane Departure Warning Actuator - Right**

Pin	Size	Color	Circuit	Function	Terminal Type ID	Option
1	0.5	BK	1550	Ground	I	—
2	0.35	BN	3038	Driver Seat Right Rear Haptic Movement Motor Control	I	—

**P53 Driver Information Display X1 (IOK)**

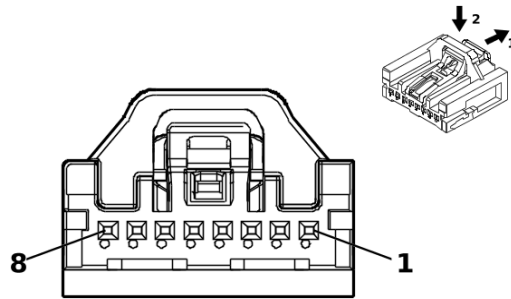

5200269

**Connector Part Information**

Harness Type: Instrument Panel Wiring Harness  
 OEM Connector: 35068228  
 Service Connector: 84769201  
 Description: 8-Way F Mini 50 Series( BK)

**Terminal Part Information**

Terminal Type ID	Terminated Lead	Diagnostic Test Probe	Terminal Removal Tool
I	Not required	EL-35616-58 (BK)	No Tool Required

**P53 Driver Information Display X1 (IOK)**

Pin	Size	Color	Circuit	Function	Terminal Type ID	Option
1	0.35	RD / WH	1340	Battery Positive Voltage	I	—
2 - 7	—	—	—	Not Occupied	—	—
8	0.35	BK / WH	1051	Signal Ground	I	—



### P53 Driver Information Display X1 (IOR)

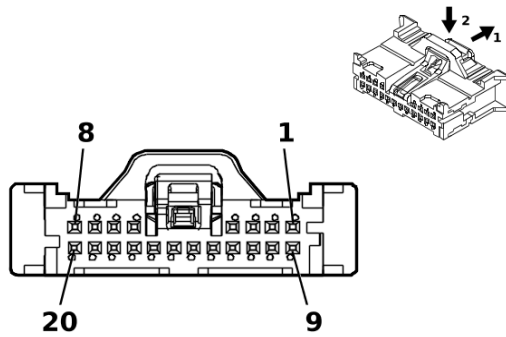

5200955

#### Connector Part Information

Harness Type: Instrument Panel Wiring Harness  
 OEM Connector: 35068196  
 Service Connector: 84769280  
 Description: 20-Way F Mini 50 Series( BK)

#### Terminal Part Information

Terminal Type ID	Terminated Lead	Diagnostic Test Probe	Terminal Removal Tool
I	84944580	EL-35616-58 (BK)	EL-38125-58

#### P53 Driver Information Display X1 (IOR)

Pin	Size	Color	Circuit	Function	Terminal Type ID	Option
1	0.35	BU / RD	11246	Infotainment Display 5 Volt Reference	I	—
2	0.35	GY / BU	11247	Infotainment Display LCD Enable Signal	I	—
3	—	—	—	Not Occupied	—	—
4	0.35	BU	11235	Radio Switch Volume Up Signal	I	—
5	0.35	GY / BN	11234	Radio Switch Volume Down Signal	I	—
6	0.35	BN / WH	11233	Radio Switch Power ON/OFF Switch Signal	I	—
7	0.35	VT / WH	11245	Radio Switch Buttons Signal	I	—
8	0.35	BU / GY	11244	Radio Switch Dimming Control	I	—
9	0.35	BU / GN	11248	Infotainment Display Backlight Dimming Control	I	—
10	—	—	—	Not Occupied	—	—
11	0.35	BK / WH	11252	Infotainment Display Low Reference	I	—
12	0.35	YE / RD	11236	Radio Switch 5 Volt Reference	I	—
13	0.35	BK / BU	11237	Radio Switch Low Reference 1	I	—
14	0.35	BU	11235	Radio Switch Volume Up Signal	I	—
15	0.35	GY / BN	11234	Radio Switch Volume Down Signal	I	—
16	0.35	BN / WH	11233	Radio Switch Power ON/OFF Switch Signal	I	—
17	0.35	VT / WH	11245	Radio Switch Buttons Signal	I	—
18	0.35	BU / GY	11244	Radio Switch Dimming Control	I	—
19	0.35	GY / VT	11249	Infotainment Display Backlight Enable Control	I	—
20	0.35	BK / GN	11238	Radio Switch Low Reference 2	I	—

**P53 Driver Information Display X2 (IOK)**

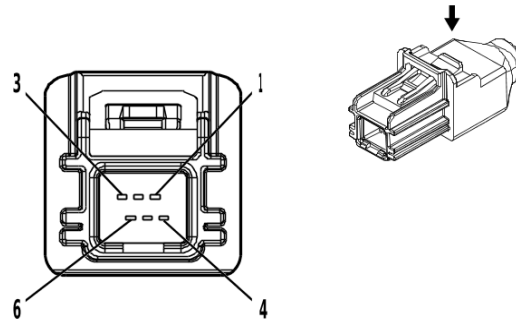

4806625

**Connector Part Information**

Harness Type: Instrument Panel Wiring Harness  
 OEM Connector: 100337-1020  
 Service Connector: Service by Cable Assembly — See Part Catalog  
 Description: 6-Way M HSAL-2 Series( BK)

**Terminal Part Information**

Terminal Type ID	Terminated Lead	Diagnostic Test Probe	Terminal Removal Tool
I	Not required	No Tool Required	No Tool Required

**P53 Driver Information Display X2 (IOK)**

Pin	Size	Color	Circuit	Function	Terminal Type ID	Option
1	0	—	7853	Center Stack LVDS (Low Voltage Differential Signaling) Low Reference	I	—
2	0	—	7854	Center Stack LVDS (Low Voltage Differential Signaling) Signal [+]	I	—
3	0	—	7855	Center Stack LVDS (Low Voltage Differential Signaling) Signal [-]	I	—
4	0	—	7848	Center Stack LVDS (Low Voltage Differential Signaling) 2 Signal [+]	I	—
5	0	—	7849	Center Stack LVDS (Low Voltage Differential Signaling) 2 Signal [-]	I	—
6	0	—	7847	Center Stack LVDS (Low Voltage Differential Signaling) 2 Low Reference	I	—

**P53 Driver Information Display X2 (IOR)**

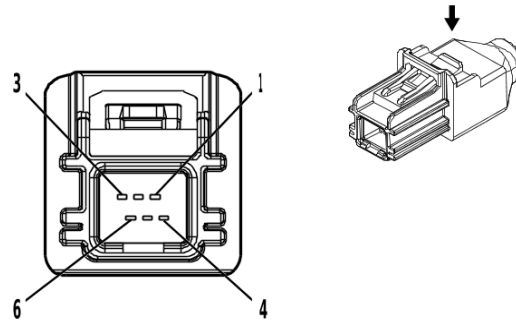

4806625

**Connector Part Information**

Harness Type: Instrument Panel Wiring Harness  
 OEM Connector: 100337-1020  
 Service Connector: Service by Cable Assembly — See Part Catalog  
 Description: 6-Way M HSAL-2 Series( BK)

**Terminal Part Information**

Terminal Type ID	Terminated Lead	Diagnostic Test Probe	Terminal Removal Tool
I	Not required	No Tool Required	No Tool Required

**P53 Driver Information Display X2 (IOR)**

Pin	Size	Color	Circuit	Function	Terminal Type ID	Option
1	0	—	4844	Radio LVDS (Low Voltage Differential Signaling) Low Reference	I	—
2	0	—	4845	Radio LVDS (Low Voltage Differential Signaling) Signal [+]	I	—
3	0	—	4846	Radio LVDS (Low Voltage Differential Signaling) Signal [-]	I	—
4 - 6	—	—	—	Not Occupied	—	—

**Q2 Air Conditioning Clutch (L3B)**

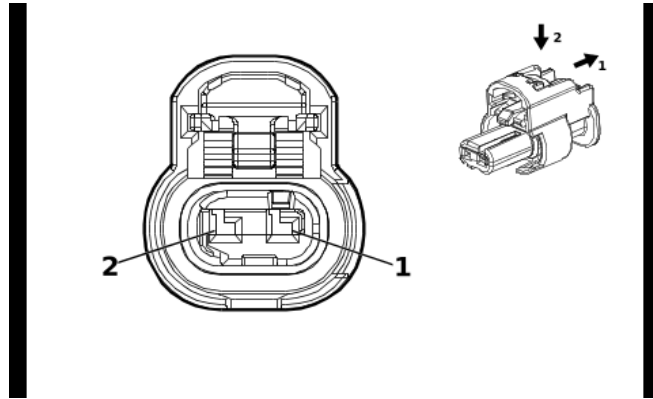

4649903

**Connector Part Information**

Harness Type: Engine Wiring Harness  
 OEM Connector: 1-2296694-1  
 Service Connector: 85519075  
 Description: 2-Way F 1.2 MCON Series, Sealed( BK)

**Terminal Part Information**

Terminal Type ID	Terminated Lead	Diagnostic Test Probe	Terminal Removal Tool
I	Not required	J-35616-12 (BU)	No Tool Required

**Q2 Air Conditioning Clutch (L3B)**

Pin	Size	Color	Circuit	Function	Terminal Type ID	Option
1	0.5	BK	450	Ground	I	—
2	0.75	BN / GN	59	Air Conditioning Compressor Clutch Control	I	—

**Q2 Air Conditioning Clutch (L84 / L87)**

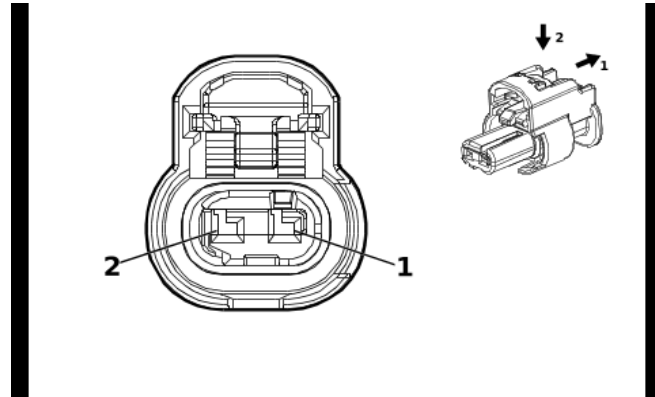

4649903

**Connector Part Information**

Harness Type: Engine Wiring Harness  
 OEM Connector: 1-2296694-1  
 Service Connector: 85519075  
 Description: 2-Way F 1.2 MCON Series, Sealed( BK)

**Terminal Part Information**

Terminal Type ID	Terminated Lead	Diagnostic Test Probe	Terminal Removal Tool
I	Not required	J-35616-16 (L-GN)	No Tool Required

**Q2 Air Conditioning Clutch (L84 / L87)**

Pin	Size	Color	Circuit	Function	Terminal Type ID	Option
1	1	BK	450	Ground	I	—
2	0.75	BN / GN	59	Air Conditioning Compressor Clutch Control	I	—

**Q2 Air Conditioning Clutch (LZ0)**

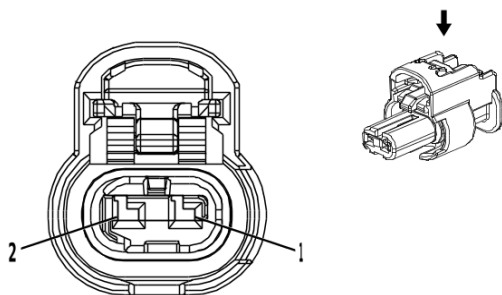

4335931

**Connector Part Information**

Harness Type: Engine Wiring Harness  
 OEM Connector: 1-2296694-2  
 Service Connector: 19366843  
 Description: 2-Way F 1.2 MCON Series, Sealed( BK)

**Terminal Part Information**

Terminal Type ID	Terminated Lead	Diagnostic Test Probe	Terminal Removal Tool
I	Not required	J-35616-12 (BU)	No Tool Required

**Q2 Air Conditioning Clutch (LZ0)**

Pin	Size	Color	Circuit	Function	Terminal Type ID	Option
1	0.75	BU / YE	7574	Air Conditioning Compressor Solenoid Valve Control	I	—
2	0.75	BU / BN	7573	Air Conditioning Compressor Solenoid Valve Control	I	—

**Q6 Camshaft Position Actuator Solenoid Valve (L84 / L87)**

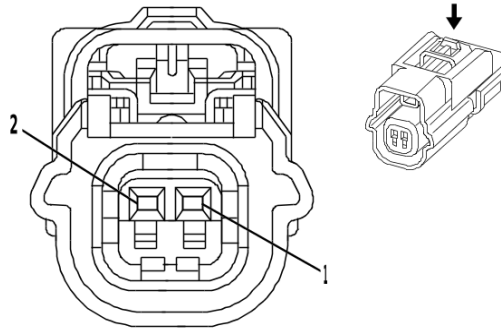

1664592

**Connector Part Information**

Harness Type: Camshaft Position Sensor Wire  
 OEM Connector: 89047381  
 Service Connector: Service by Harness - See Part Catalog  
 Description: 2-Way F 0.64 Kaizen Series, Sealed( BK)

**Terminal Part Information**

Terminal Type ID	Terminated Lead	Diagnostic Test Probe	Terminal Removal Tool
I	Not required	J-35616-64B (L-BU)	No Tool Required

**Q6 Camshaft Position Actuator Solenoid Valve (L84 / L87)**

Pin	Size	Color	Circuit	Function	Terminal Type ID	Option
1	0.5	BK / BN	6753	Camshaft Position Actuator Solenoid Valve W Low Reference	I	—
2	0.5	VT / BN	5284	Intake Camshaft Position Actuator Solenoid Valve 1	I	—

**Q6E Camshaft Position Actuator Solenoid Valve - Exhaust**

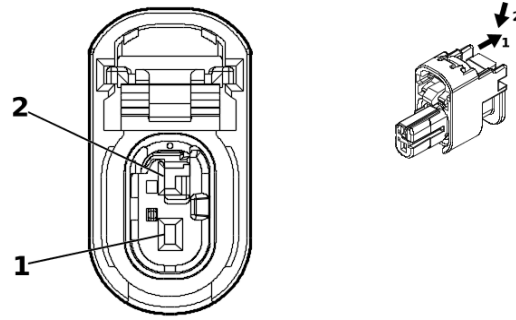

5340268

**Connector Part Information**

Harness Type: Engine Wiring Harness  
 OEM Connector: 1-2296702-2  
 Service Connector: 19371204  
 Description: 2-Way F 1.2 MCON-CB Series, Sealed( BK)

**Terminal Part Information**

Terminal Type ID	Terminated Lead	Diagnostic Test Probe	Terminal Removal Tool
I	Not required	J-35616-16 (L-GN)	No Tool Required

**Q6E Camshaft Position Actuator Solenoid Valve - Exhaust**

Pin	Size	Color	Circuit	Function	Terminal Type ID	Option
1	0.5	GY / BU	5282	Exhaust Camshaft Position Actuator Solenoid Valve 1	I	—
2	0.5	BK / VT	6754	Camshaft Position Actuator Solenoid Valve X Low Reference	I	—



**Q6F Camshaft Position Actuator Solenoid Valve - Intake**

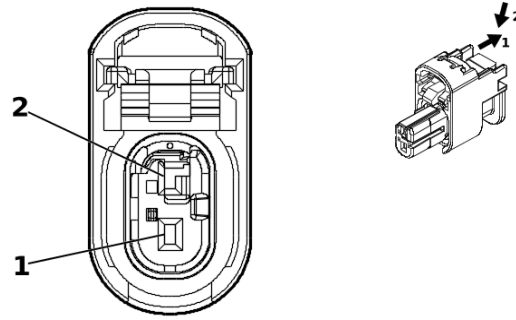

5340268

**Connector Part Information**

Harness Type: Engine Wiring Harness  
 OEM Connector: 1-2296702-2  
 Service Connector: 19371204  
 Description: 2-Way F 1.2 MCON-CB Series, Sealed( BK)

**Terminal Part Information**

Terminal Type ID	Terminated Lead	Diagnostic Test Probe	Terminal Removal Tool
I	Not required	J-35616-16 (L-GN)	No Tool Required

**Q6F Camshaft Position Actuator Solenoid Valve - Intake**

Pin	Size	Color	Circuit	Function	Terminal Type ID	Option
1	0.5	VT / BN	5284	Intake Camshaft Position Actuator Solenoid Valve 1	I	—
2	0.5	BK / BN	6753	Camshaft Position Actuator Solenoid Valve W Low Reference	I	—

**Q9F Differential Locking Actuator - Front (G93)**

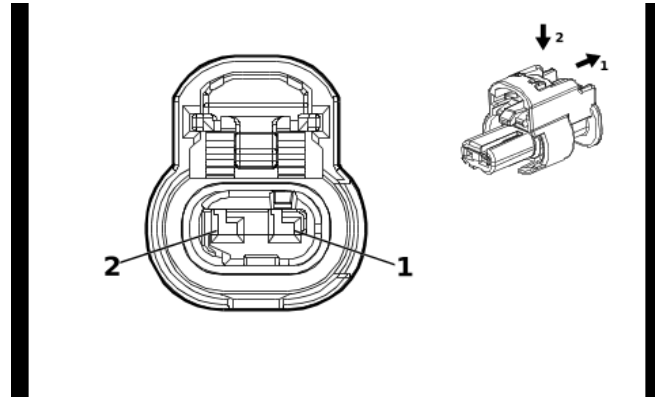

4649903

**Connector Part Information**

Harness Type: Front Differential Locking Actuator Jumper Wiring Harness  
 OEM Connector: 13512365  
 Service Connector: Service by Harness - See Part Catalog  
 Description: 2-Way F 1.2 MCON Series, Sealed( BK)

**Terminal Part Information**

Terminal Type ID	Terminated Lead	Diagnostic Test Probe	Terminal Removal Tool
I	Not required	J-35616-12 (BU)	No Tool Required

**Q9F Differential Locking Actuator - Front (G93)**

Pin	Size	Color	Circuit	Function	Terminal Type ID	Option
1	0.75	VT / WH	7256	Front Differential Lock Actuator Control	I	—
2	0.75	WH / BK	7254	Front Differential Lock Actuator Low Control	I	—

**Q9R Differential Locking Actuator - Rear (G94)**

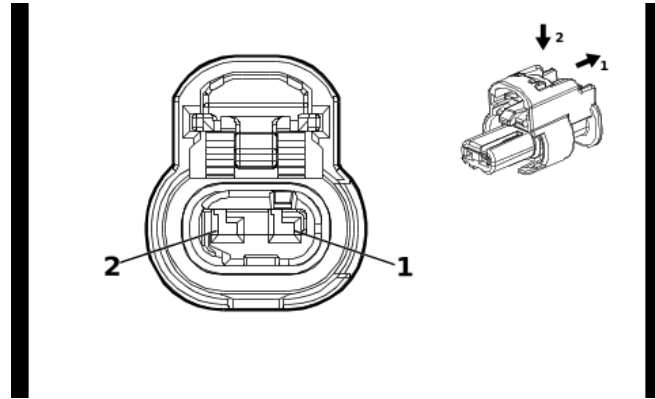

4649903

**Connector Part Information**

Harness Type: Chassis Rear Wiring Harness Extension Harness  
 OEM Connector: 13512365  
 Service Connector: Service by Harness - See Part Catalog  
 Description: 2-Way F 1.2 MCON Series, Sealed( BK)

**Terminal Part Information**

Terminal Type ID	Terminated Lead	Diagnostic Test Probe	Terminal Removal Tool
I	Not required	J-35616-16 (L-GN)	No Tool Required

**Q9R Differential Locking Actuator - Rear (G94)**

Pin	Size	Color	Circuit	Function	Terminal Type ID	Option
1	0.75	VT / BN	7258	Rear Differential Lock Actuator Control	I	G94
2	0.75	GY / BK	7253	Rear Differential Lock Actuator Low Control	I	G94

**Q12 Evaporative Emission Canister Purge Solenoid Valve (L3B)**

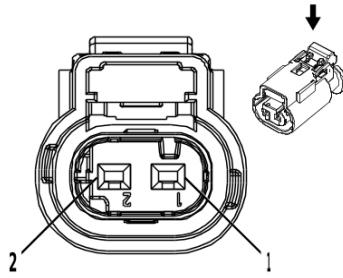

2717066

**Connector Part Information**

Harness Type: Engine Wiring Harness  
 OEM Connector: 10010337  
 Service Connector: 13587326  
 Description: 2-Way F 1.2 Multilock Series, Sealed( BK)

**Terminal Part Information**

Terminal Type ID	Terminated Lead	Diagnostic Test Probe	Terminal Removal Tool
I	Not required	J-35616-16 (L-GN)	No Tool Required

**Q12 Evaporative Emission Canister Purge Solenoid Valve (L3B)**

Pin	Size	Color	Circuit	Function	Terminal Type ID	Option
1	0.5	VT / BU	5293	Powertrain Main Relay Fused Supply Voltage 4	I	—
2	0.5	GN / BU	428	EVAP Canister Purge Solenoid Control	I	—

**Q12 Evaporative Emission Canister Purge Solenoid Valve (L84 / L87)**

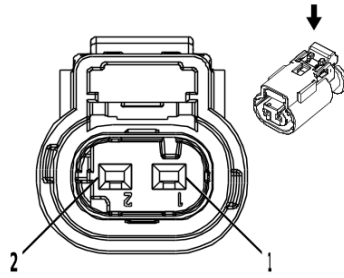

2717066

**Connector Part Information**

Harness Type: Engine Wiring Harness  
 OEM Connector: 10010337  
 Service Connector: 13587326  
 Description: 2-Way F 1.2 Multilock Series, Sealed( BK)

**Terminal Part Information**

Terminal Type ID	Terminated Lead	Diagnostic Test Probe	Terminal Removal Tool
I	Not required	J-35616-16 (L-GN)	No Tool Required

**Q12 Evaporative Emission Canister Purge Solenoid Valve (L84 / L87)**

Pin	Size	Color	Circuit	Function	Terminal Type ID	Option
1	0.5	VT / BU	5293	Powertrain Main Relay Fused Supply Voltage 4	I	—
2	0.5	GN / BU	428	EVAP Canister Purge Solenoid Control	I	—

**Q13 Evaporative Emission Canister Vent Solenoid Valve (FHS)**

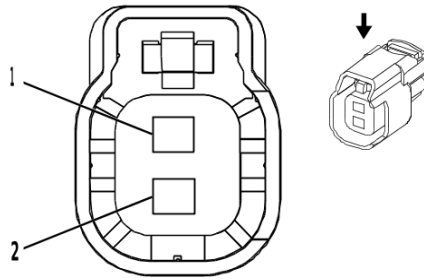

2422378

**Connector Part Information**

Harness Type: Chassis Wiring Harness  
 OEM Connector: 34062-0028  
 Service Connector: 13579002  
 Description: 2-Way F 1.5 Series, Sealed( BK)

**Terminal Part Information**

Terminal Type ID	Terminated Lead	Diagnostic Test Probe	Terminal Removal Tool
I	Not required	J-35616-14 (GN)	No Tool Required

**Q13 Evaporative Emission Canister Vent Solenoid Valve (FHS)**

Pin	Size	Color	Circuit	Function	Terminal Type ID	Option
1	0.5	WH	1310	EVAP Vent Solenoid Valve Control	I	—
2	0.5	RD / WH	3440	Battery Positive Voltage	I	—

## Q14A Exhaust Gas Recirculation Valve 1

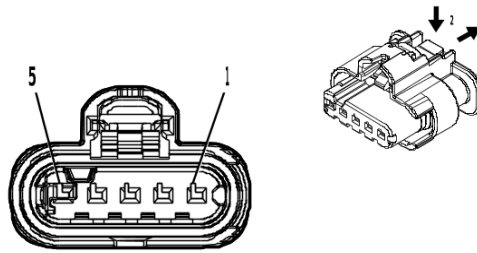

4997783

### Connector Part Information

Harness Type: Engine Wiring Harness  
 OEM Connector: 1-2296697-1  
 Service Connector: 19371195  
 Description: 5-Way F 1.2 MCON-CB Series, Sealed( BK)

### Terminal Part Information

Terminal Type ID	Terminated Lead	Diagnostic Test Probe	Terminal Removal Tool
I	Not required	J-35616-16 (L-GN)	No Tool Required

### Q14A Exhaust Gas Recirculation Valve 1

Pin	Size	Color	Circuit	Function	Terminal Type ID	Option
1	0.5	BU / RD	460	Engine Control Sensors 5 Volt Reference 1	I	—
2	0.5	BN / WH	5763	Exhaust Gas Recirculation Position Signal	I	—
3	0.5	BK / YE	548	Engine Control Sensors Low Reference 1	I	—
4	0.75	WH / VT	5764	Exhaust Gas Recirculation Valve High Control	I	—
5	0.75	VT / BK	5746	Exhaust Gas Recirculation Valve Low Control	I	—

## Q14B Exhaust Gas Recirculation Valve 2

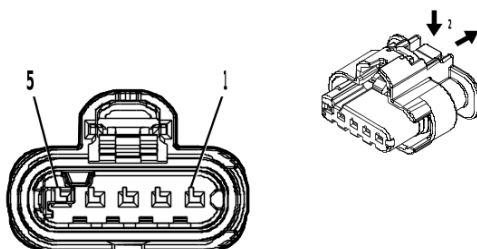

4997783

### Connector Part Information

Harness Type: Engine Wiring Harness

OEM Connector: 1-2296697-1

Service Connector: 19371195

Description: 5-Way F 1.2 MCON-CB Series, Sealed( BK)

### Terminal Part Information

Terminal Type ID	Terminated Lead	Diagnostic Test Probe	Terminal Removal Tool
I	Not required	J-35616-16 (L-GN)	No Tool Required

### Q14B Exhaust Gas Recirculation Valve 2

Pin	Size	Color	Circuit	Function	Terminal Type ID	Option
1	0.5	BK / YE	548	Engine Control Sensors Low Reference 1	I	—
2	0.5	BU / GN	4012	Exhaust Gas Recirculation 2 Valve Position Sensor Signal	I	—
3	0.5	BU / RD	460	Engine Control Sensors 5 Volt Reference 1	I	—
4	0.75	BU / WH	4014	Exhaust Gas Recirculation 2 Valve Open Control	I	—
5	0.75	BU / BN	4013	Exhaust Gas Recirculation 2 Valve Close Control	I	—



**Q17A Fuel Injector 1 (L3B)**

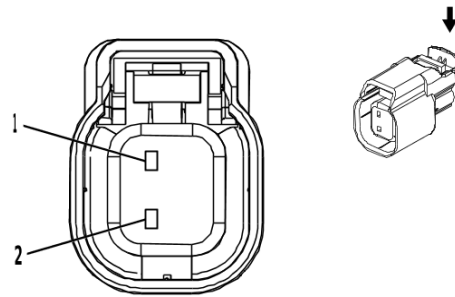

2792100

**Connector Part Information**

Harness Type: Fuel Injector Wiring Harness  
 OEM Connector: 34062-4008  
 Service Connector: Service by Harness - See Part Catalog  
 Description: 2-Way F 1.5 Series, Sealed( BK)

**Terminal Part Information**

Terminal Type ID	Terminated Lead	Diagnostic Test Probe	Terminal Removal Tool
I	Not required	J-35616-14 (GN)	No Tool Required

**Q17A Fuel Injector 1 (L3B)**

Pin	Size	Color	Circuit	Function	Terminal Type ID	Option
1	0.8	BN	4801	Direct Fuel Injector High Voltage Control Cylinder 1	I	—
2	0.8	BN / WH	4901	Direct Fuel Injector High Voltage Supply Cylinder 1	I	—

**Q17A Fuel Injector 1 (L84 / L87)**

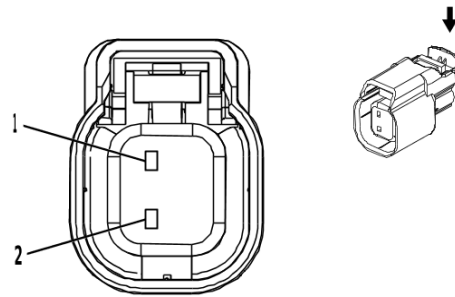

2792100

**Connector Part Information**

Harness Type: Fuel Injector Wiring Harness - Bank 1  
 OEM Connector: 340624008  
 Service Connector: Service by Harness - See Part Catalog  
 Description: 2-Way F 1.5 Series, Sealed( BK)

**Terminal Part Information**

Terminal Type ID	Terminated Lead	Diagnostic Test Probe	Terminal Removal Tool
I	Not required	J-35616-2A (GY)	No Tool Required

**Q17A Fuel Injector 1 (L84 / L87)**

Pin	Size	Color	Circuit	Function	Terminal Type ID	Option
1	0.8	BN / WH	4901	Direct Fuel Injector High Voltage Supply Cylinder 1	I	—
2	0.8	BN	4801	Direct Fuel Injector High Voltage Control Cylinder 1	I	—

**Q17A Fuel Injector 1 (LZ0)**

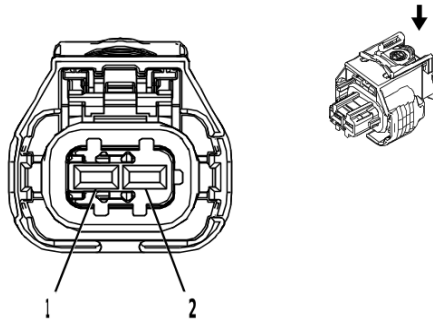

2845578

**Connector Part Information**

Harness Type: Fuel Injector Wiring Harness  
 OEM Connector: 1 928 405 715  
 Service Connector: Service by Harness - See Part Catalog  
 Description: 2-Way F 2.8 Series, Sealed( BK)

**Terminal Part Information**

Terminal Type ID	Terminated Lead	Diagnostic Test Probe	Terminal Removal Tool
I	Not required	J-35616-35 (VT)	No Tool Required

**Q17A Fuel Injector 1 (LZ0)**

Pin	Size	Color	Circuit	Function	Terminal Type ID	Option
1	1.5	BN / WH	4901	Direct Fuel Injector High Voltage Supply Cylinder 1	I	—
2	1.5	BN	4801	Direct Fuel Injector High Voltage Control Cylinder 1	I	—

**Q17B Fuel Injector 2 (L3B)**

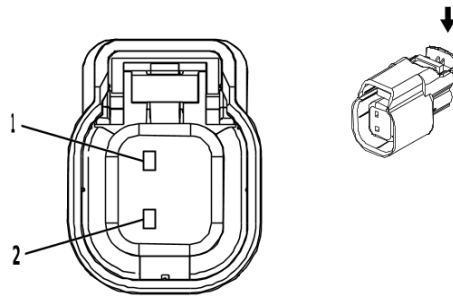

2792100

**Connector Part Information**

Harness Type: Fuel Injector Wiring Harness  
 OEM Connector: 34062-4008  
 Service Connector: Service by Harness - See Part Catalog  
 Description: 2-Way F 1.5 Series, Sealed( BK)

**Terminal Part Information**

Terminal Type ID	Terminated Lead	Diagnostic Test Probe	Terminal Removal Tool
I	Not required	J-35616-14 (GN)	No Tool Required

**Q17B Fuel Injector 2 (L3B)**

Pin	Size	Color	Circuit	Function	Terminal Type ID	Option
1	0.8	BU	4802	Direct Fuel Injector High Voltage Control Cylinder 2	I	—
2	0.8	BU / GY	4902	Direct Fuel Injector High Voltage Supply Cylinder 2	I	—

**Q17B Fuel Injector 2 (L84 / L87)**

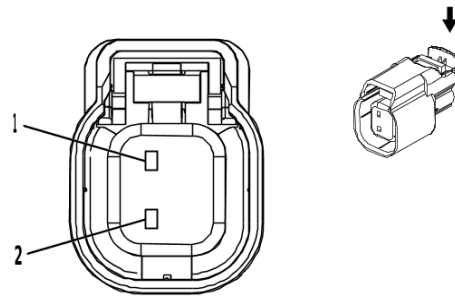

2792100

**Connector Part Information**

Harness Type: Fuel Injector Wiring Harness - Bank 2  
 OEM Connector: 340624008  
 Service Connector: Service by Harness - See Part Catalog  
 Description: 2-Way F 1.5 Series, Sealed( BK)

**Terminal Part Information**

Terminal Type ID	Terminated Lead	Diagnostic Test Probe	Terminal Removal Tool
I	Not required	J-35616-2A (GY)	No Tool Required

**Q17B Fuel Injector 2 (L84 / L87)**

Pin	Size	Color	Circuit	Function	Terminal Type ID	Option
1	0.8	BU / GY	4902	Direct Fuel Injector High Voltage Supply Cylinder 2	I	—
2	0.8	BU	4802	Direct Fuel Injector High Voltage Control Cylinder 2	I	—

**Q17B Fuel Injector 2 (LZ0)**

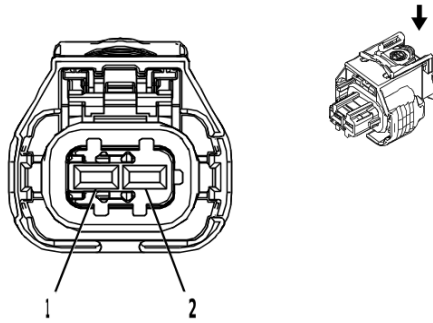

2845578

**Connector Part Information**

Harness Type: Fuel Injector Wiring Harness  
 OEM Connector: 1 928 405 715  
 Service Connector: Service by Harness - See Part Catalog  
 Description: 2-Way F 2.8 Series, Sealed( BK)

**Terminal Part Information**

Terminal Type ID	Terminated Lead	Diagnostic Test Probe	Terminal Removal Tool
I	Not required	J-35616-35 (VT)	No Tool Required

**Q17B Fuel Injector 2 (LZ0)**

Pin	Size	Color	Circuit	Function	Terminal Type ID	Option
1	1.5	BU / GY	4902	Direct Fuel Injector High Voltage Supply Cylinder 2	I	—
2	1.5	BU	4802	Direct Fuel Injector High Voltage Control Cylinder 2	I	—

**Q17C Fuel Injector 3 (L3B)**

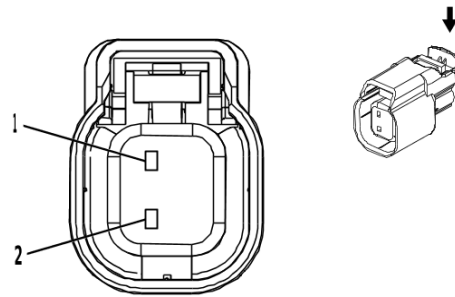

2792100

**Connector Part Information**

Harness Type: Fuel Injector Wiring Harness  
 OEM Connector: 34062-4008  
 Service Connector: Service by Harness - See Part Catalog  
 Description: 2-Way F 1.5 Series, Sealed( BK)

**Terminal Part Information**

Terminal Type ID	Terminated Lead	Diagnostic Test Probe	Terminal Removal Tool
I	Not required	J-35616-14 (GN)	No Tool Required

**Q17C Fuel Injector 3 (L3B)**

Pin	Size	Color	Circuit	Function	Terminal Type ID	Option
1	0.8	GN	4803	Direct Fuel Injector High Voltage Control Cylinder 3	I	—
2	0.8	GN / GY	4903	Direct Fuel Injector High Voltage Supply Cylinder 3	I	—

**Q17C Fuel Injector 3 (L84 / L87)**

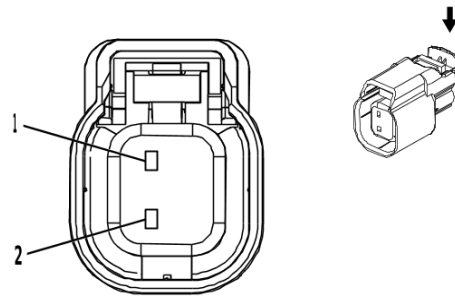

2792100

**Connector Part Information**

Harness Type: Fuel Injector Wiring Harness - Bank 1  
 OEM Connector: 340624008  
 Service Connector: Service by Harness - See Part Catalog  
 Description: 2-Way F 1.5 Series, Sealed( BK)

**Terminal Part Information**

Terminal Type ID	Terminated Lead	Diagnostic Test Probe	Terminal Removal Tool
I	Not required	J-35616-2A (GY)	No Tool Required

**Q17C Fuel Injector 3 (L84 / L87)**

Pin	Size	Color	Circuit	Function	Terminal Type ID	Option
1	0.8	GN / GY	4903	Direct Fuel Injector High Voltage Supply Cylinder 3	I	—
2	0.8	GN	4803	Direct Fuel Injector High Voltage Control Cylinder 3	I	—



**Q17C Fuel Injector 3 (LZ0)**

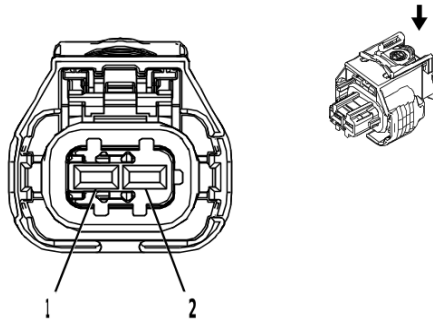

2845578

**Connector Part Information**

Harness Type: Fuel Injector Wiring Harness  
 OEM Connector: 1 928 405 715  
 Service Connector: Service by Harness - See Part Catalog  
 Description: 2-Way F 2.8 Series, Sealed( BK)

**Terminal Part Information**

Terminal Type ID	Terminated Lead	Diagnostic Test Probe	Terminal Removal Tool
I	Not required	J-35616-35 (VT)	No Tool Required

**Q17C Fuel Injector 3 (LZ0)**

Pin	Size	Color	Circuit	Function	Terminal Type ID	Option
1	1.5	GN / GY	4903	Direct Fuel Injector High Voltage Supply Cylinder 3	I	—
2	1.5	GN	4803	Direct Fuel Injector High Voltage Control Cylinder 3	I	—

**Q17D Fuel Injector 4 (L3B)**

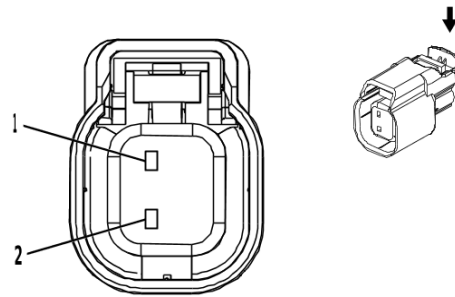

2792100

**Connector Part Information**

Harness Type: Fuel Injector Wiring Harness  
 OEM Connector: 34062-4008  
 Service Connector: Service by Harness - See Part Catalog  
 Description: 2-Way F 1.5 Series, Sealed( BK)

**Terminal Part Information**

Terminal Type ID	Terminated Lead	Diagnostic Test Probe	Terminal Removal Tool
I	Not required	J-35616-14 (GN)	No Tool Required

**Q17D Fuel Injector 4 (L3B)**

Pin	Size	Color	Circuit	Function	Terminal Type ID	Option
1	0.8	GY / BU	4804	Direct Fuel Injector High Voltage Control Cylinder 4	I	—
2	0.8	BU / WH	4904	Direct Fuel Injector High Voltage Supply Cylinder 4	I	—

**Q17D Fuel Injector 4 (L84 / L87)**

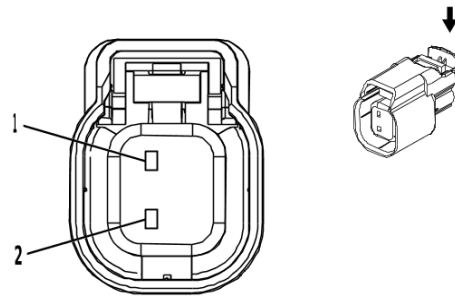

2792100

**Connector Part Information**

Harness Type: Fuel Injector Wiring Harness - Bank 2  
 OEM Connector: 340624008  
 Service Connector: Service by Harness - See Part Catalog  
 Description: 2-Way F 1.5 Series, Sealed( BK)

**Terminal Part Information**

Terminal Type ID	Terminated Lead	Diagnostic Test Probe	Terminal Removal Tool
I	Not required	J-35616-2A (GY)	No Tool Required

**Q17D Fuel Injector 4 (L84 / L87)**

Pin	Size	Color	Circuit	Function	Terminal Type ID	Option
1	0.8	BU / WH	4904	Direct Fuel Injector High Voltage Supply Cylinder 4	I	—
2	0.8	GY / BU	4804	Direct Fuel Injector High Voltage Control Cylinder 4	I	—

**Q17D Fuel Injector 4 (LZ0)**

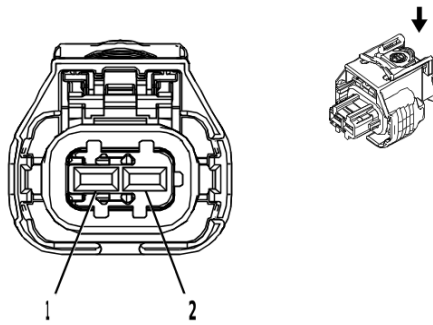

2845578

**Connector Part Information**

Harness Type: Fuel Injector Wiring Harness  
 OEM Connector: 1 928 405 715  
 Service Connector: Service by Harness - See Part Catalog  
 Description: 2-Way F 2.8 Series, Sealed( BK)

**Terminal Part Information**

Terminal Type ID	Terminated Lead	Diagnostic Test Probe	Terminal Removal Tool
I	Not required	J-35616-35 (VT)	No Tool Required

**Q17D Fuel Injector 4 (LZ0)**

Pin	Size	Color	Circuit	Function	Terminal Type ID	Option
1	1.5	BU / WH	4904	Direct Fuel Injector High Voltage Supply Cylinder 4	I	—
2	1.5	GY / BU	4804	Direct Fuel Injector High Voltage Control Cylinder 4	I	—

**Q17E Fuel Injector 5 (L84 / L87)**

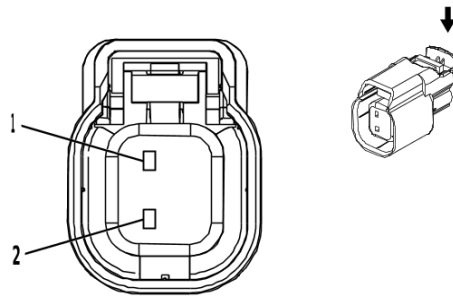

2792100

**Connector Part Information**

Harness Type: Fuel Injector Wiring Harness - Bank 1  
 OEM Connector: 340624008  
 Service Connector: Service by Harness - See Part Catalog  
 Description: 2-Way F 1.5 Series, Sealed( BK)

**Terminal Part Information**

Terminal Type ID	Terminated Lead	Diagnostic Test Probe	Terminal Removal Tool
I	Not required	J-35616-2A (GY)	No Tool Required

**Q17E Fuel Injector 5 (L84 / L87)**

Pin	Size	Color	Circuit	Function	Terminal Type ID	Option
1	0.8	GN / WH	4905	Direct Fuel Injector High Voltage Supply Cylinder 5	I	—
2	0.8	WH / GN	4805	Direct Fuel Injector High Voltage Control Cylinder 5	I	—

**Q17E Fuel Injector 5 (LZ0)**

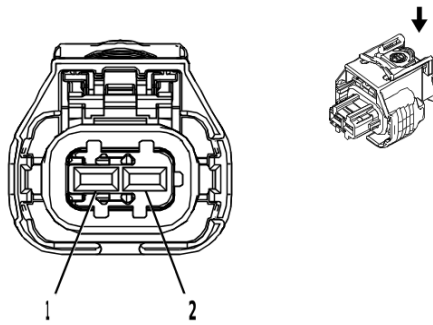

2845578

**Connector Part Information**

Harness Type: Fuel Injector Wiring Harness  
 OEM Connector: 1 928 405 715  
 Service Connector: Service by Harness - See Part Catalog  
 Description: 2-Way F 2.8 Series, Sealed( BK)

**Terminal Part Information**

Terminal Type ID	Terminated Lead	Diagnostic Test Probe	Terminal Removal Tool
I	Not required	J-35616-35 (VT)	No Tool Required

**Q17E Fuel Injector 5 (LZ0)**

Pin	Size	Color	Circuit	Function	Terminal Type ID	Option
1	1.5	GN / WH	4905	Direct Fuel Injector High Voltage Supply Cylinder 5	I	—
2	1.5	WH / GN	4805	Direct Fuel Injector High Voltage Control Cylinder 5	I	—

**Q17F Fuel Injector 6 (L84 / L87)**

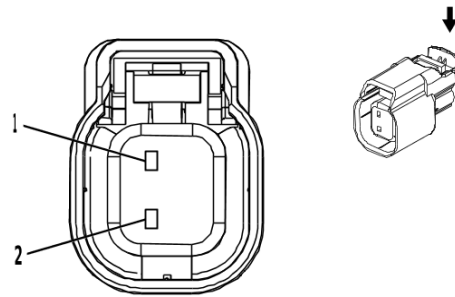

2792100

**Connector Part Information**

Harness Type: Fuel Injector Wiring Harness - Bank 2  
 OEM Connector: 340624008  
 Service Connector: Service by Harness - See Part Catalog  
 Description: 2-Way F 1.5 Series, Sealed( BK)

**Terminal Part Information**

Terminal Type ID	Terminated Lead	Diagnostic Test Probe	Terminal Removal Tool
I	Not required	J-35616-2A (GY)	No Tool Required

**Q17F Fuel Injector 6 (L84 / L87)**

Pin	Size	Color	Circuit	Function	Terminal Type ID	Option
1	0.8	VT / GY	4906	Direct Fuel Injector High Voltage Supply Cylinder 6	I	—
2	0.8	VT / GN	4806	Direct Fuel Injector High Voltage Control Cylinder 6	I	—

**Q17F Fuel Injector 6 (LZ0)**

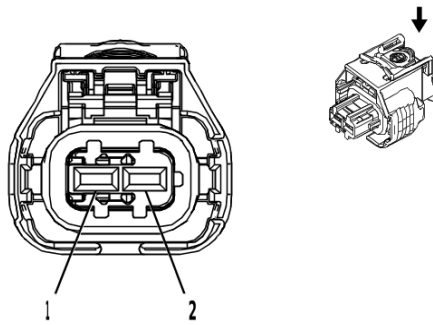

2845578

**Connector Part Information**

Harness Type: Fuel Injector Wiring Harness  
 OEM Connector: 1 928 405 715  
 Service Connector: Service by Harness - See Part Catalog  
 Description: 2-Way F 2.8 Series, Sealed( BK)

**Terminal Part Information**

Terminal Type ID	Terminated Lead	Diagnostic Test Probe	Terminal Removal Tool
I	Not required	J-35616-35 (VT)	No Tool Required

**Q17F Fuel Injector 6 (LZ0)**

Pin	Size	Color	Circuit	Function	Terminal Type ID	Option
1	1.5	VT / GY	4906	Direct Fuel Injector High Voltage Supply Cylinder 6	I	—
2	1.5	VT / GN	4806	Direct Fuel Injector High Voltage Control Cylinder 6	I	—



**Q17G Fuel Injector 7 (L84 / L87)**

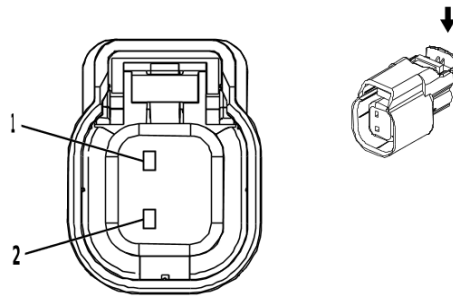

2792100

**Connector Part Information**

Harness Type: Fuel Injector Wiring Harness - Bank 1  
 OEM Connector: 340624008  
 Service Connector: Service by Harness - See Part Catalog  
 Description: 2-Way F 1.5 Series, Sealed( BK)

**Terminal Part Information**

Terminal Type ID	Terminated Lead	Diagnostic Test Probe	Terminal Removal Tool
I	Not required	J-35616-2A (GY)	No Tool Required

**Q17G Fuel Injector 7 (L84 / L87)**

Pin	Size	Color	Circuit	Function	Terminal Type ID	Option
1	0.8	WH / YE	4907	Direct Fuel Injector High Voltage Supply Cylinder 7	I	—
2	0.8	YE / GY	4807	Direct Fuel Injector High Voltage Control Cylinder 7	I	—

**Q17H Fuel Injector 8 (L84 / L87)**

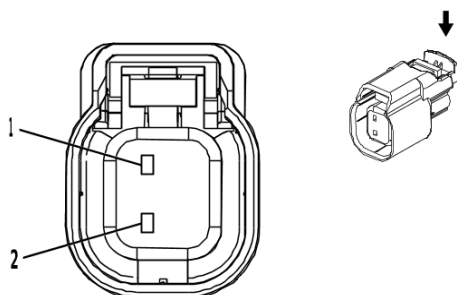

2792100

**Connector Part Information**

Harness Type: Fuel Injector Wiring Harness - Bank 2  
 OEM Connector: 340624008  
 Service Connector: Service by Harness - See Part Catalog  
 Description: 2-Way F 1.5 Series, Sealed( BK)

**Terminal Part Information**

Terminal Type ID	Terminated Lead	Diagnostic Test Probe	Terminal Removal Tool
I	Not required	J-35616-2A (GY)	No Tool Required

**Q17H Fuel Injector 8 (L84 / L87)**

Pin	Size	Color	Circuit	Function	Terminal Type ID	Option
1	0.8	GY / WH	4908	Direct Fuel Injector High Voltage Supply Cylinder 8	I	—
2	0.8	GY	4808	Direct Fuel Injector High Voltage Control Cylinder 8	I	—

## Q18A Fuel Pressure Regulator 1

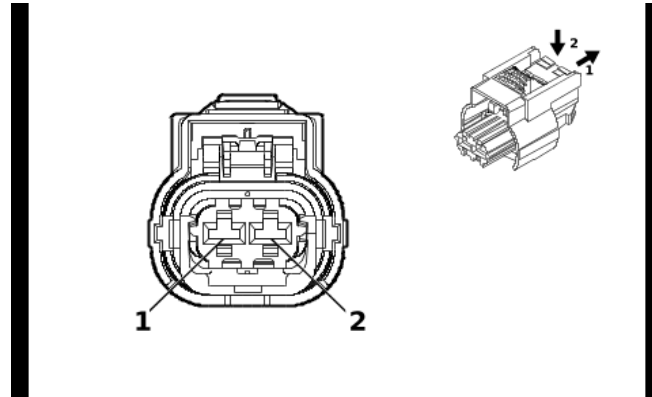

4992524

### Connector Part Information

Harness Type: Engine Wiring Harness  
 OEM Connector: 35182447  
 Service Connector: 84941154  
 Description: 2-Way F 2.8 MCP Series, Sealed( BK)

### Terminal Part Information

Terminal Type ID	Terminated Lead	Diagnostic Test Probe	Terminal Removal Tool
I	Not required	J-35616-4A (PU)	No Tool Required

### Q18A Fuel Pressure Regulator 1

Pin	Size	Color	Circuit	Function	Terminal Type ID	Option
1	0.75	YE / VT	7245	High Pressure Fuel Pump Low Enable Signal	I	—
2	0.75	GY / BN	7244	High Pressure Fuel Pump High Side Control	I	—

**Q18B Fuel Pressure Regulator 2**

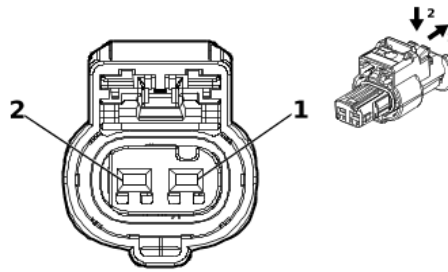

6055996

**Connector Part Information**

Harness Type: Engine Wiring Harness  
 OEM Connector: 5-2297795-1  
 Service Connector: 85625525  
 Description: 2-Way F 1.2 HPF Series, Sealed( BK)

**Terminal Part Information**

Terminal Type ID	Terminated Lead	Diagnostic Test Probe	Terminal Removal Tool
I	Not required	J-35616-12 (BU)	No Tool Required

**Q18B Fuel Pressure Regulator 2**

Pin	Size	Color	Circuit	Function	Terminal Type ID	Option
1	0.5	BK / YE	2834	Fuel Rail Pressure Solenoid Valve Low Control	I	—
2	0.5	BU / WH	2530	Fuel Rail Pressure Solenoid Valve Control	I	—

**Q18C Fuel Pressure Regulator 3**

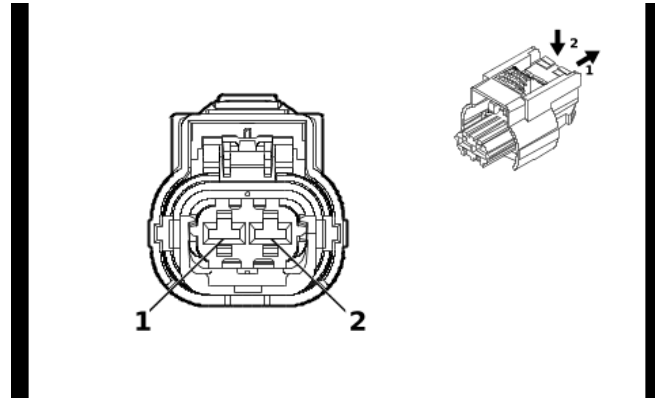

4992524

**Connector Part Information**

Harness Type: Engine Wiring Harness  
 OEM Connector: 35182447  
 Service Connector: 84941154  
 Description: 2-Way F 2.8 MCP Series, Sealed( BK)

**Terminal Part Information**

Terminal Type ID	Terminated Lead	Diagnostic Test Probe	Terminal Removal Tool
I	Not required	J-35616-4A (PU)	No Tool Required

**Q18C Fuel Pressure Regulator 3**

Pin	Size	Color	Circuit	Function	Terminal Type ID	Option
1	0.75	YE / VT	2420	Fuel High Pressure Pump Low Enable Signal	I	—
2	0.75	GY / BN	2419	Fuel High Pressure Pump High Side Supply Voltage	I	—

**Q22 Intake Manifold Tuning Solenoid Valve**

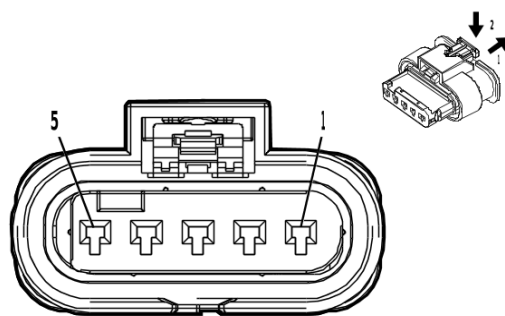

3338689

**Connector Part Information**

Harness Type: Engine Wiring Harness  
 OEM Connector: 1-1718806-1  
 Service Connector: 19119351  
 Description: 5-Way F 1.2 MCON-LL Series, Sealed( BK)

**Terminal Part Information**

Terminal Type ID	Terminated Lead	Diagnostic Test Probe	Terminal Removal Tool
I	Not required	J-35616-12 (BU)	No Tool Required

**Q22 Intake Manifold Tuning Solenoid Valve**

Pin	Size	Color	Circuit	Function	Terminal Type ID	Option
1	0.5	BK / YE	548	Engine Control Sensors Low Reference 1	I	—
2	0.5	GN / GY	7316	Intake Manifold Runner Valve Actuator Control	I	—
3	0.5	BU / RD	460	Engine Control Sensors 5 Volt Reference 1	I	—
4	0.75	BK / BU	1408	Variable Swirl Valve Close Control	I	—
5	0.75	BK / GN	1389	Variable Swirl Valve Open Control	I	—

**Q37LFB Front Shock Absorber Actuator - Left**

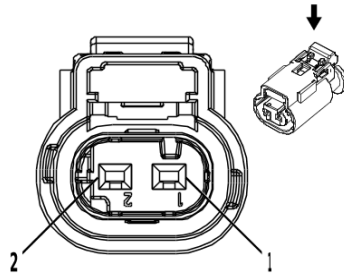

2717066

**Connector Part Information**

Harness Type: Electronic Suspension Strut Wiring Harness Extension Harness  
 OEM Connector: 13503566  
 Service Connector: Service by Harness - See Part Catalog  
 Description: 2-Way F 1.2 Multilock Series, Sealed( BK)

**Terminal Part Information**

Terminal Type ID	Terminated Lead	Diagnostic Test Probe	Terminal Removal Tool
I	Not required	J-35616-16 (L-GN)	No Tool Required

**Q37LFB Front Shock Absorber Actuator - Left**

Pin	Size	Color	Circuit	Function	Terminal Type ID	Option
1	0.75	BU / WH	1107	Left Front Shock Absorber Actuator Control	I	—
2	0.75	GY	1113	Left Front Shock Absorber Actuator Control	I	—

**Q37LRB Rear Shock Absorber Actuator - Left (Z45)**

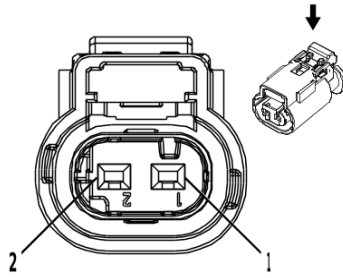

2717066

**Connector Part Information**

Harness Type: Chassis Rear Wiring Harness Extension Harness  
 OEM Connector: 13503566  
 Service Connector: Service by Harness - See Part Catalog  
 Description: 2-Way F 1.2 Multilock Series, Sealed( BK)

**Terminal Part Information**

Terminal Type ID	Terminated Lead	Diagnostic Test Probe	Terminal Removal Tool
I	Not required	J-35616-16 (L-GN)	No Tool Required

**Q37LRB Rear Shock Absorber Actuator - Left (Z45)**

Pin	Size	Color	Circuit	Function	Terminal Type ID	Option
1	0.75	BU / GY	1114	Left Rear Shock Absorber Actuator Control	I	Z45
2	0.75	GN / VT	1115	Left Rear Shock Absorber Actuator Control	I	Z45



**Q37RFB Front Shock Absorber Actuator - Right**

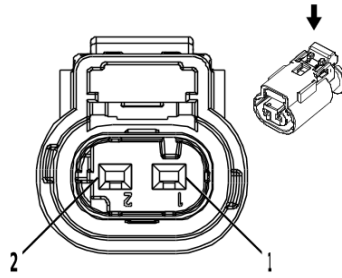

2717066

**Connector Part Information**

Harness Type: Electronic Suspension Strut Wiring Harness Extension Harness  
 OEM Connector: 13503566  
 Service Connector: Service by Harness - See Part Catalog  
 Description: 2-Way F 1.2 Multilock Series, Sealed( BK)

**Terminal Part Information**

Terminal Type ID	Terminated Lead	Diagnostic Test Probe	Terminal Removal Tool
I	Not required	J-35616-16 (L-GN)	No Tool Required

**Q37RFB Front Shock Absorber Actuator - Right**

Pin	Size	Color	Circuit	Function	Terminal Type ID	Option
1	0.75	BU / WH	1116	Right Front Shock Absorber Actuator Control	I	—
2	0.75	GY	1117	Right Front Shock Absorber Actuator Control	I	—

**Q37RRB Rear Shock Absorber Actuator - Right (Z45)**

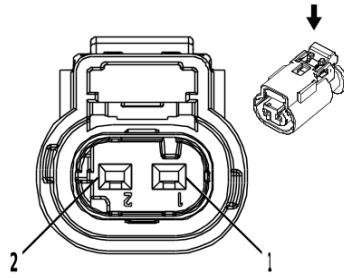

2717066

**Connector Part Information**

Harness Type: Chassis Rear Wiring Harness Extension Harness  
 OEM Connector: 13503566  
 Service Connector: Service by Harness - See Part Catalog  
 Description: 2-Way F 1.2 Multilock Series, Sealed( BK)

**Terminal Part Information**

Terminal Type ID	Terminated Lead	Diagnostic Test Probe	Terminal Removal Tool
I	Not required	J-35616-16 (L-GN)	No Tool Required

**Q37RRB Rear Shock Absorber Actuator - Right (Z45)**

Pin	Size	Color	Circuit	Function	Terminal Type ID	Option
1	0.75	BN / GN	1118	Right Rear Shock Absorber Actuator Control	I	Z45
2	0.75	GN / GY	1119	Right Rear Shock Absorber Actuator Control	I	Z45

## Q38 Throttle Body

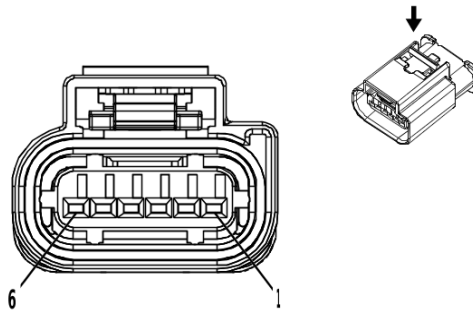

3747579

### Connector Part Information

Harness Type: Engine Wiring Harness  
 OEM Connector: 2272975-5  
 Service Connector: 19352911  
 Description: 6-Way F 1.2 MCON Series, Sealed( BK)

### Terminal Part Information

Terminal Type ID	Terminated Lead	Diagnostic Test Probe	Terminal Removal Tool
I	Not required	J-35616-12 (BU)	No Tool Required

### Q38 Throttle Body

Pin	Size	Color	Circuit	Function	Terminal Type ID	Option
1	0.5	YE	581	Throttle Actuator Open Control	I	L84 / L87 / L3B
	0.75	YE	581	Throttle Actuator Open Control	I	LZ0
2	0.5	BN / WH	582	Throttle Actuator Close Control	I	L84 / L87 / L3B
	0.75	BN / WH	582	Throttle Actuator Close Control	I	LZ0
3	0.5	BU / WH	3630	Throttle Position Sensor SENT 1 Signal	I	—
4	0.5	BK / BN	2752	Throttle Position Sensor Low Reference	I	L84 / L87 / L3B
	0.5	BK / YE	548	Engine Control Sensors Low Reference 1	I	LZ0
5	0.5	BN / RD	2701	Throttle Position Sensor 5V Reference	I	L84 / L87 / L3B
	0.5	BU / RD	460	Engine Control Sensors 5 Volt Reference 1	I	LZ0
6	—	—	—	Not Occupied	—	—

**Q40 Turbocharger Bypass Valve Solenoid**

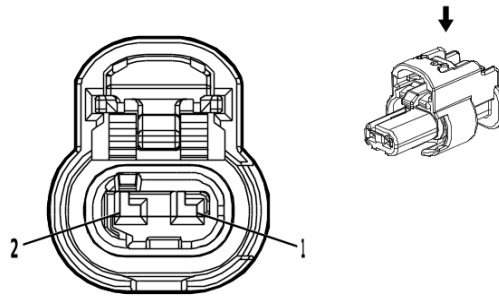

4690744

**Connector Part Information**

Harness Type: Engine Wiring Harness  
 OEM Connector: 1-2296694-3  
 Service Connector: 19366871  
 Description: 2-Way F 1.2 MCON Series, Sealed( BK)

**Terminal Part Information**

Terminal Type ID	Terminated Lead	Diagnostic Test Probe	Terminal Removal Tool
I	Not required	J-35616-16 (L-GN)	No Tool Required

**Q40 Turbocharger Bypass Valve Solenoid**

Pin	Size	Color	Circuit	Function	Terminal Type ID	Option
1	0.5	VT / BU	5293	Powertrain Main Relay Fused Supply Voltage 4	I	—
2	0.5	GN	3060	Turbocharger Bypass Solenoid Valve Control Bank 1	I	—

**Q44 Engine Oil Pressure Control Solenoid Valve (L87)**

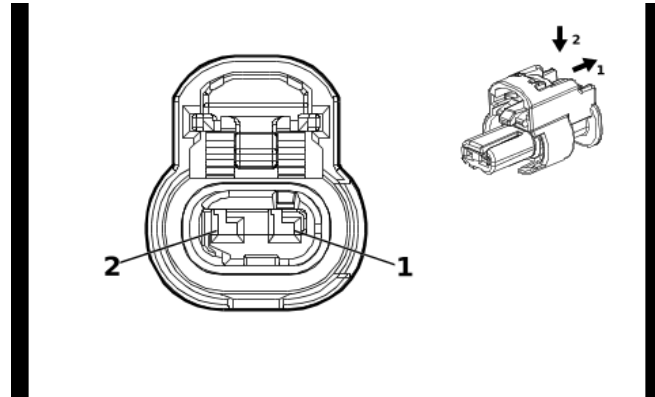

4036662

**Connector Part Information**

Harness Type: Oil Pump Flow Control Solenoid Valve Wiring Harness  
 OEM Connector: 13514238  
 Service Connector: Service by Harness - See Part Catalog  
 Description: 2-Way F 1.2 MCON-CB Series, Sealed( BK)

**Terminal Part Information**

Terminal Type ID	Terminated Lead	Diagnostic Test Probe	Terminal Removal Tool
I	Not required	J-35616-16 (L-GN)	No Tool Required

**Q44 Engine Oil Pressure Control Solenoid Valve (L87)**

Pin	Size	Color	Circuit	Function	Terminal Type ID	Option
1	0.5	VT / BU	5293	Powertrain Main Relay Fused Supply Voltage 4	I	—
2	0.5	BU	179	Engine Oil Pump Control	I	—

**Q44 Engine Oil Pressure Control Solenoid Valve (LZ0)**

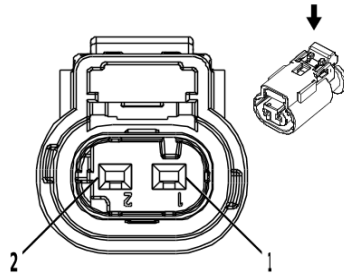

2717066

**Connector Part Information**

Harness Type: Oil Pump Flow Control Solenoid Valve Wiring Harness  
 OEM Connector: 13503566  
 Service Connector: Service by Harness - See Part Catalog  
 Description: 2-Way F 1.2 Multilock Series, Sealed( BK)

**Terminal Part Information**

Terminal Type ID	Terminated Lead	Diagnostic Test Probe	Terminal Removal Tool
I	Not required	J-35616-12 (BU)	No Tool Required

**Q44 Engine Oil Pressure Control Solenoid Valve (LZ0)**

Pin	Size	Color	Circuit	Function	Terminal Type ID	Option
1	0.5	YE / BN	106	Oil Pump Motor Control	I	—
2	0.5	BU	179	Engine Oil Pump Control	I	—

**Q46 Air Conditioning Compressor Solenoid Valve (L3B)**

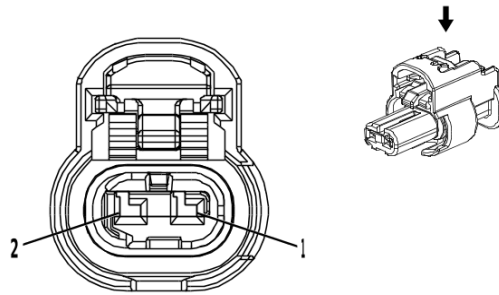

4335931

**Connector Part Information**

Harness Type: Engine Wiring Harness  
 OEM Connector: 1-2296694-2  
 Service Connector: 19366843  
 Description: 2-Way F 1.2 MCON Series, Sealed( BK)

**Terminal Part Information**

Terminal Type ID	Terminated Lead	Diagnostic Test Probe	Terminal Removal Tool
I	Not required	J-35616-12 (BU)	No Tool Required

**Q46 Air Conditioning Compressor Solenoid Valve (L3B)**

Pin	Size	Color	Circuit	Function	Terminal Type ID	Option
1	0.75	BU / YE	7574	Air Conditioning Compressor Solenoid Valve Control	I	—
2	0.75	BU / BN	7573	Air Conditioning Compressor Solenoid Valve Control	I	—

**Q46 Air Conditioning Compressor Solenoid Valve (L84 / L87)**

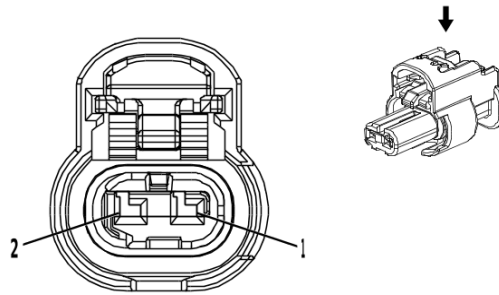

4335931

**Connector Part Information**

Harness Type: Engine Wiring Harness  
 OEM Connector: 1-2296694-2  
 Service Connector: 19366843  
 Description: 2-Way F 1.2 MCON Series, Sealed( BK)

**Terminal Part Information**

Terminal Type ID	Terminated Lead	Diagnostic Test Probe	Terminal Removal Tool
I	Not required	J-35616-16 (L-GN)	No Tool Required

**Q46 Air Conditioning Compressor Solenoid Valve (L84 / L87)**

Pin	Size	Color	Circuit	Function	Terminal Type ID	Option
1	0.75	BU / YE	7574	Air Conditioning Compressor Solenoid Valve Control	I	—
2	0.75	BU / BN	7573	Air Conditioning Compressor Solenoid Valve Control	I	—



**Q46 Air Conditioning Compressor Solenoid Valve (LZ0)**

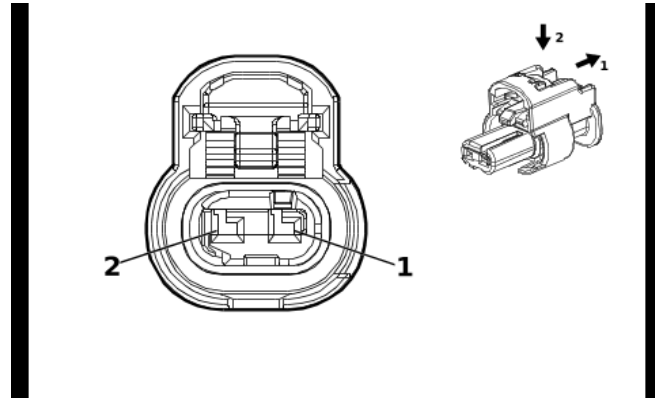

4649903

**Connector Part Information**

Harness Type: Engine Wiring Harness  
 OEM Connector: 1-2296694-1  
 Service Connector: 85519075  
 Description: 2-Way F 1.2 MCON Series, Sealed( BK)

**Terminal Part Information**

Terminal Type ID	Terminated Lead	Diagnostic Test Probe	Terminal Removal Tool
I	Not required	J-35616-12 (BU)	No Tool Required

**Q46 Air Conditioning Compressor Solenoid Valve (LZ0)**

Pin	Size	Color	Circuit	Function	Terminal Type ID	Option
1	0.75	BK	450	Ground	I	—
2	0.75	BN / GN	59	Air Conditioning Compressor Clutch Control	I	—

**Q61 Reductant Fluid Injector**

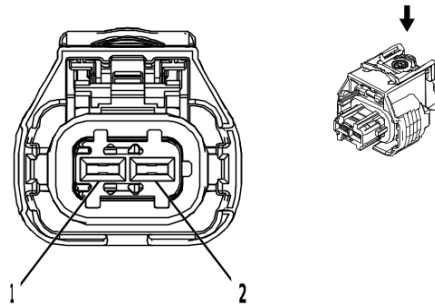

2577394

**Connector Part Information**

Harness Type: Engine Wiring Harness  
 OEM Connector: 1 928 405 714  
 Service Connector: 13384371  
 Description: 2-Way F 2.8 Series, Sealed( BK)

**Terminal Part Information**

Terminal Type ID	Terminated Lead	Diagnostic Test Probe	Terminal Removal Tool
I	Not required	J-35616-35 (VT)	No Tool Required

**Q61 Reductant Fluid Injector**

Pin	Size	Color	Circuit	Function	Terminal Type ID	Option
1	0.75	BN / WH	3100	Diesel Exhaust Fluid Dosing Valve Low Control	I	—
2	0.75	BN	3099	Diesel Exhaust Fluid Dosing Valve High Control	I	—

**Q61B Reductant Fluid Injector 2**

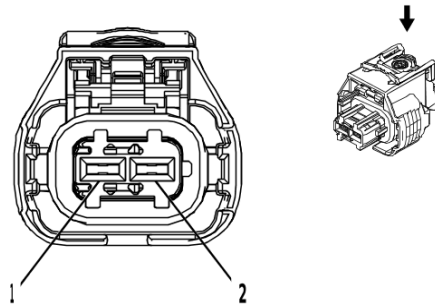

2577394

**Connector Part Information**

Harness Type: Engine Wiring Harness  
 OEM Connector: 1 928 405 714  
 Service Connector: 13384371  
 Description: 2-Way F 2.8 Series, Sealed( BK)

**Terminal Part Information**

Terminal Type ID	Terminated Lead	Diagnostic Test Probe	Terminal Removal Tool
I	Not required	J-35616-35 (VT)	No Tool Required

**Q61B Reductant Fluid Injector 2**

Pin	Size	Color	Circuit	Function	Terminal Type ID	Option
1	0.75	BU	11615	Diesel Exhaust Fluid Dosing Valve High Control 2	I	—
2	0.75	BU / YE	11616	Diesel Exhaust Fluid Dosing Valve Low Control 2	I	—

**Q74 Engine Coolant Bypass Valve**

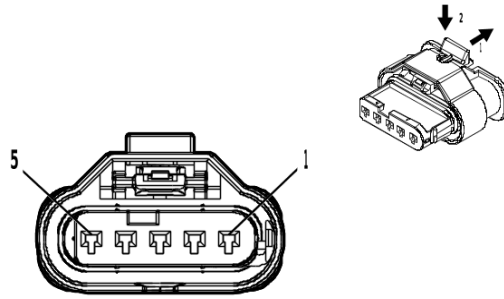

4994456

**Connector Part Information**

Harness Type: Engine Wiring Harness  
 OEM Connector: 2-2236898-5  
 Service Connector: 19371191  
 Description: 5-Way F 1.2 MCON-LL Series, Sealed( NA)

**Terminal Part Information**

Terminal Type ID	Terminated Lead	Diagnostic Test Probe	Terminal Removal Tool
I	Not required	J-35616-12 (BU)	No Tool Required

**Q74 Engine Coolant Bypass Valve**

Pin	Size	Color	Circuit	Function	Terminal Type ID	Option
1	0.75	BU	2976	Coolant Diverter Valve Actuator Control Open	I	—
2	0.75	BU / BN	2977	Coolant Diverter Valve Actuator Control Close	I	—
3	0.5	WH / RD	480	Engine Control Vehicle Sensors 5 Volt Reference 1	I	—
4	0.5	BU / GY	2978	Coolant Diverter Valve Position Signal	I	—
5	0.5	BK / GN	580	Engine Control Sensors Low Reference 2	I	—

**Q77A Transmission Control Solenoid Valve 1 (MHS / MQC)**

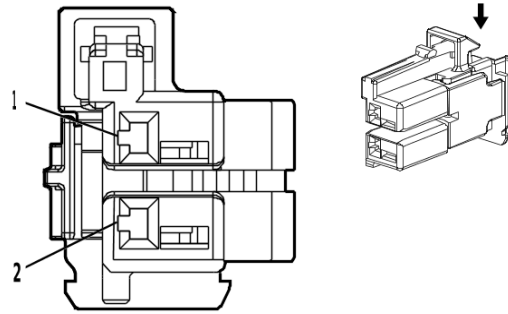

4672650

**Connector Part Information**

Harness Type: Automatic Transmission Wiring Harness - Control  
 OEM Connector: 2289523-1  
 Service Connector: Service by Harness - See Part Catalog  
 Description: 2-Way F 1.2 MCON Series( BN)

**Terminal Part Information**

Terminal Type ID	Terminated Lead	Diagnostic Test Probe	Terminal Removal Tool
I	Not required	J-35616-12 (BU)	No Tool Required

**Q77A Transmission Control Solenoid Valve 1 (MHS / MQC)**

Pin	Size	Color	Circuit	Function	Terminal Type ID	Option
1	0.5	WH	6388	Transmission High Side Driver 2 Control	I	—
2	0.5	BU / GN	6404	Clutch Solenoid Valve E Control	I	—

**Q77A Transmission Control Solenoid Valve 1 (MHT / MI2 / MQB)**

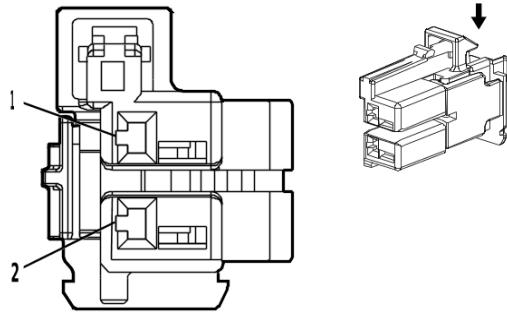

4672650

**Connector Part Information**

Harness Type: Automatic Transmission Wiring Harness - Control  
 OEM Connector: 2289523-1  
 Service Connector: Service by Harness - See Part Catalog  
 Description: 2-Way F 1.2 MCON Series( BN)

**Terminal Part Information**

Terminal Type ID	Terminated Lead	Diagnostic Test Probe	Terminal Removal Tool
I	Not required	J-35616-12 (BU)	No Tool Required

**Q77A Transmission Control Solenoid Valve 1 (MHT / MI2 / MQB)**

Pin	Size	Color	Circuit	Function	Terminal Type ID	Option
1	0.5	WH	6388	Transmission High Side Driver 2 Control	I	—
2	0.5	BU / GN	6404	Clutch Solenoid Valve E Control	I	—

**Q77A Transmission Control Solenoid Valve 1 (MQE)**

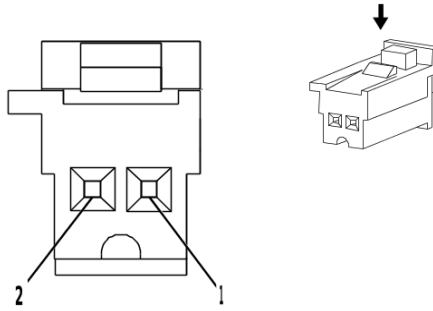

4051391

**Connector Part Information**

Harness Type: Automatic Transmission Wiring Harness - Control  
 OEM Connector: 13956948  
 Service Connector: Service by Harness - See Part Catalog  
 Description: 2-Way F 0.64 MTS Series( VT)

**Terminal Part Information**

Terminal Type ID	Terminated Lead	Diagnostic Test Probe	Terminal Removal Tool
I	Not required	J-35616-64B (L-BU)	No Tool Required

**Q77A Transmission Control Solenoid Valve 1 (MQE)**

Pin	Size	Color	Circuit	Function	Terminal Type ID	Option
1	0.5	BN	6400	Clutch Solenoid Valve A Control	I	—
2	0.5	GY / BN	6388	Transmission High Side Driver 2 Control	I	—

**Q77B Transmission Control Solenoid Valve 2 (MHS / MQC)**

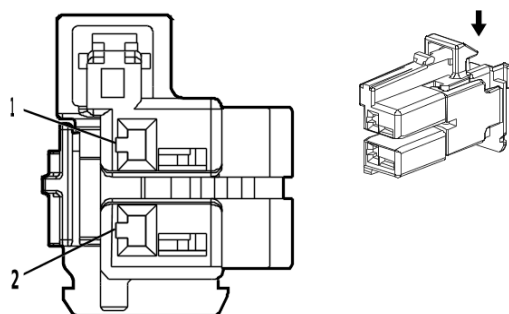

4672650

**Connector Part Information**

Harness Type: Automatic Transmission Wiring Harness - Control  
 OEM Connector: 2289523-1  
 Service Connector: Service by Harness - See Part Catalog  
 Description: 2-Way F 1.2 MCON Series( BN)

**Terminal Part Information**

Terminal Type ID	Terminated Lead	Diagnostic Test Probe	Terminal Removal Tool
I	Not required	J-35616-12 (BU)	No Tool Required

**Q77B Transmission Control Solenoid Valve 2 (MHS / MQC)**

Pin	Size	Color	Circuit	Function	Terminal Type ID	Option
1	0.5	WH	6388	Transmission High Side Driver 2 Control	I	—
2	0.5	GN / BN	6403	Clutch Solenoid Valve D Control	I	—



**Q77B Transmission Control Solenoid Valve 2 (MHT / MI2 / MQB)**

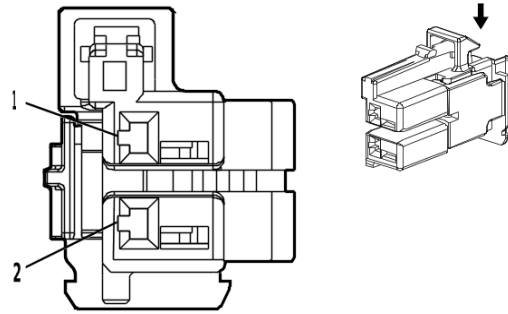

4672650

**Connector Part Information**

Harness Type: Automatic Transmission Wiring Harness - Control  
 OEM Connector: 2289523-1  
 Service Connector: Service by Harness - See Part Catalog  
 Description: 2-Way F 1.2 MCON Series( BN)

**Terminal Part Information**

Terminal Type ID	Terminated Lead	Diagnostic Test Probe	Terminal Removal Tool
I	Not required	J-35616-12 (BU)	No Tool Required

**Q77B Transmission Control Solenoid Valve 2 (MHT / MI2 / MQB)**

Pin	Size	Color	Circuit	Function	Terminal Type ID	Option
1	0.5	WH	6388	Transmission High Side Driver 2 Control	I	—
2	0.5	GN / BN	6403	Clutch Solenoid Valve D Control	I	—

**Q77B Transmission Control Solenoid Valve 2 (MQE)**

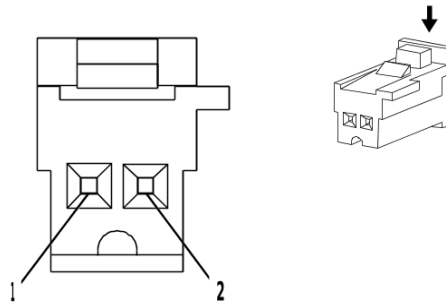

4008644

**Connector Part Information**

Harness Type: Automatic Transmission Wiring Harness - Control  
 OEM Connector: 13941672  
 Service Connector: Service by Harness - See Part Catalog  
 Description: 2-Way F 0.64 MTS Series( GY)

**Terminal Part Information**

Terminal Type ID	Terminated Lead	Diagnostic Test Probe	Terminal Removal Tool
I	Not required	J-35616-64B (L-BU)	No Tool Required

**Q77B Transmission Control Solenoid Valve 2 (MQE)**

Pin	Size	Color	Circuit	Function	Terminal Type ID	Option
1	0.5	BU	6401	Clutch Solenoid Valve B Control	I	—
2	0.5	GY / BN	6388	Transmission High Side Driver 2 Control	I	—

**Q77C Transmission Control Solenoid Valve 3 (MHS / MQC)**

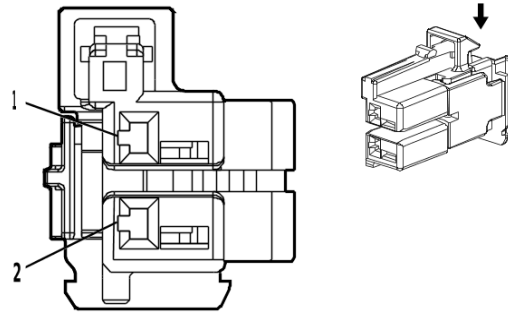

4672650

**Connector Part Information**

Harness Type: Automatic Transmission Wiring Harness - Control  
 OEM Connector: 2289523-1  
 Service Connector: Service by Harness - See Part Catalog  
 Description: 2-Way F 1.2 MCON Series( BN)

**Terminal Part Information**

Terminal Type ID	Terminated Lead	Diagnostic Test Probe	Terminal Removal Tool
I	Not required	J-35616-12 (BU)	No Tool Required

**Q77C Transmission Control Solenoid Valve 3 (MHS / MQC)**

Pin	Size	Color	Circuit	Function	Terminal Type ID	Option
1	0.5	WH	6388	Transmission High Side Driver 2 Control	I	—
2	0.5	GY	6402	Clutch Solenoid Valve C Control	I	—

**Q77C Transmission Control Solenoid Valve 3 (MHT / MI2 / MQB)**

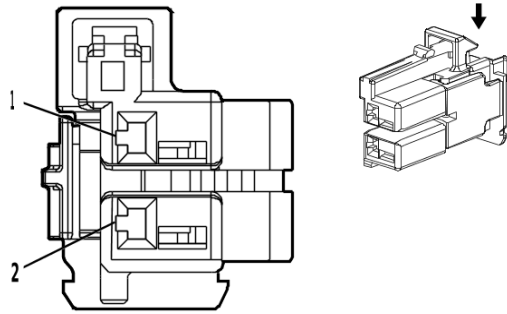

4672650

**Connector Part Information**

Harness Type: Automatic Transmission Wiring Harness - Control  
 OEM Connector: 2289523-1  
 Service Connector: Service by Harness - See Part Catalog  
 Description: 2-Way F 1.2 MCON Series( BN)

**Terminal Part Information**

Terminal Type ID	Terminated Lead	Diagnostic Test Probe	Terminal Removal Tool
I	Not required	J-35616-12 (BU)	No Tool Required

**Q77C Transmission Control Solenoid Valve 3 (MHT / MI2 / MQB)**

Pin	Size	Color	Circuit	Function	Terminal Type ID	Option
1	0.5	WH	6388	Transmission High Side Driver 2 Control	I	—
2	0.5	GY	6402	Clutch Solenoid Valve C Control	I	—

**Q77C Transmission Control Solenoid Valve 3 (MQE)**

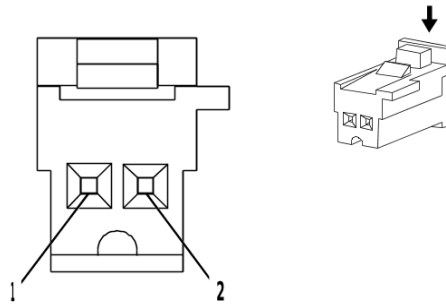

4008644

**Connector Part Information**

Harness Type: Automatic Transmission Wiring Harness - Control  
 OEM Connector: 13941672  
 Service Connector: Service by Harness - See Part Catalog  
 Description: 2-Way F 0.64 MTS Series( GY)

**Terminal Part Information**

Terminal Type ID	Terminated Lead	Diagnostic Test Probe	Terminal Removal Tool
I	Not required	J-35616-64B (L-BU)	No Tool Required

**Q77C Transmission Control Solenoid Valve 3 (MQE)**

Pin	Size	Color	Circuit	Function	Terminal Type ID	Option
1	0.5	GY	6402	Clutch Solenoid Valve C Control	I	—
2	0.5	GY / BN	6388	Transmission High Side Driver 2 Control	I	—

**Q77D Transmission Control Solenoid Valve 4 (MHS / MQC)**

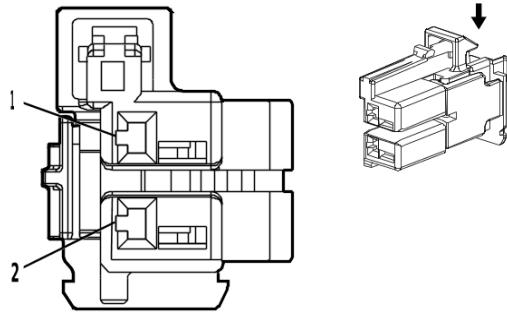

4672650

**Connector Part Information**

Harness Type: Automatic Transmission Wiring Harness - Control  
 OEM Connector: 2289523-1  
 Service Connector: Service by Harness - See Part Catalog  
 Description: 2-Way F 1.2 MCON Series( BN)

**Terminal Part Information**

Terminal Type ID	Terminated Lead	Diagnostic Test Probe	Terminal Removal Tool
I	Not required	J-35616-12 (BU)	No Tool Required

**Q77D Transmission Control Solenoid Valve 4 (MHS / MQC)**

Pin	Size	Color	Circuit	Function	Terminal Type ID	Option
1	0.5	WH	6388	Transmission High Side Driver 2 Control	I	—
2	0.5	BN / WH	4509	Transmission Clutch F Control	I	—

**Q77D Transmission Control Solenoid Valve 4 (MHT / MI2 / MQB)**

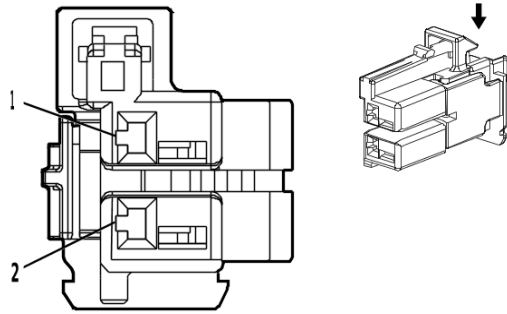

4672650

**Connector Part Information**

Harness Type: Automatic Transmission Wiring Harness - Control  
 OEM Connector: 2289523-1  
 Service Connector: Service by Harness - See Part Catalog  
 Description: 2-Way F 1.2 MCON Series( BN)

**Terminal Part Information**

Terminal Type ID	Terminated Lead	Diagnostic Test Probe	Terminal Removal Tool
I	Not required	J-35616-12 (BU)	No Tool Required

**Q77D Transmission Control Solenoid Valve 4 (MHT / MI2 / MQB)**

Pin	Size	Color	Circuit	Function	Terminal Type ID	Option
1	0.5	WH	6388	Transmission High Side Driver 2 Control	I	—
2	0.5	BN / WH	4509	Transmission Clutch F Control	I	—

**Q77D Transmission Control Solenoid Valve 4 (MQE)**

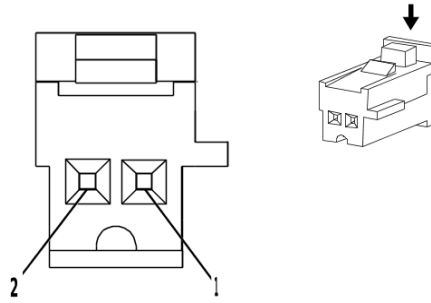

4008636

**Connector Part Information**

Harness Type: Automatic Transmission Wiring Harness - Control  
 OEM Connector: 13947283  
 Service Connector: Service by Harness - See Part Catalog  
 Description: 2-Way F 0.64 MTS Series( NA)

**Terminal Part Information**

Terminal Type ID	Terminated Lead	Diagnostic Test Probe	Terminal Removal Tool
I	Not required	J-35616-64B (L-BU)	No Tool Required

**Q77D Transmission Control Solenoid Valve 4 (MQE)**

Pin	Size	Color	Circuit	Function	Terminal Type ID	Option
1	0.5	WH	4508	Transmission Clutch G Control	I	—
2	0.5	GN / GY	6387	Transmission High Side Driver 1 Control	I	—



**Q77E Transmission Control Solenoid Valve 5 (MHS / MQC)**

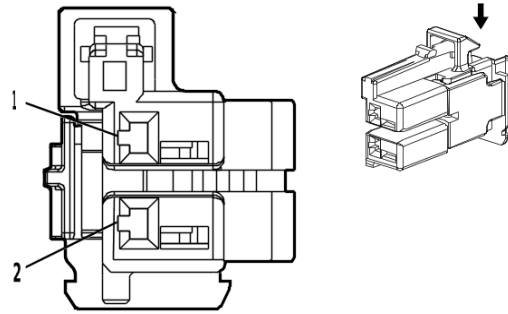

4672650

**Connector Part Information**

Harness Type: Automatic Transmission Wiring Harness - Control  
 OEM Connector: 2289523-1  
 Service Connector: Service by Harness - See Part Catalog  
 Description: 2-Way F 1.2 MCON Series( BN)

**Terminal Part Information**

Terminal Type ID	Terminated Lead	Diagnostic Test Probe	Terminal Removal Tool
I	Not required	J-35616-12 (BU)	No Tool Required

**Q77E Transmission Control Solenoid Valve 5 (MHS / MQC)**

Pin	Size	Color	Circuit	Function	Terminal Type ID	Option
1	0.5	WH	6388	Transmission High Side Driver 2 Control	I	—
2	0.5	YE / VT	4507	Transmission Clutch H Control	I	—

**Q77E Transmission Control Solenoid Valve 5 (MHT / MI2 / MQB)**

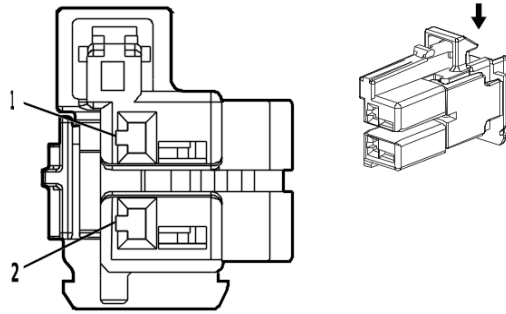

4672650

**Connector Part Information**

Harness Type: Automatic Transmission Wiring Harness - Control  
 OEM Connector: 2289523-1  
 Service Connector: Service by Harness - See Part Catalog  
 Description: 2-Way F 1.2 MCON Series( BN)

**Terminal Part Information**

Terminal Type ID	Terminated Lead	Diagnostic Test Probe	Terminal Removal Tool
I	Not required	J-35616-12 (BU)	No Tool Required

**Q77E Transmission Control Solenoid Valve 5 (MHT / MI2 / MQB)**

Pin	Size	Color	Circuit	Function	Terminal Type ID	Option
1	0.5	WH	6388	Transmission High Side Driver 2 Control	I	—
2	0.5	YE / VT	4507	Transmission Clutch H Control	I	—

**Q77E Transmission Control Solenoid Valve 5 (MQE)**

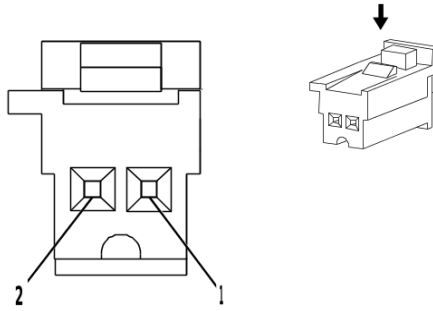

4051391

**Connector Part Information**

Harness Type: Automatic Transmission Wiring Harness - Control  
 OEM Connector: 13956948  
 Service Connector: Service by Harness - See Part Catalog  
 Description: 2-Way F 0.64 MTS Series( VT)

**Terminal Part Information**

Terminal Type ID	Terminated Lead	Diagnostic Test Probe	Terminal Removal Tool
I	Not required	J-35616-64B (L-BU)	No Tool Required

**Q77E Transmission Control Solenoid Valve 5 (MQE)**

Pin	Size	Color	Circuit	Function	Terminal Type ID	Option
1	0.5	WH / BU	4507	Transmission Clutch H Control	I	—
2	0.5	GN / GY	6387	Transmission High Side Driver 1 Control	I	—

**Q77F Transmission Control Solenoid Valve 6 (MHS / MQC)**

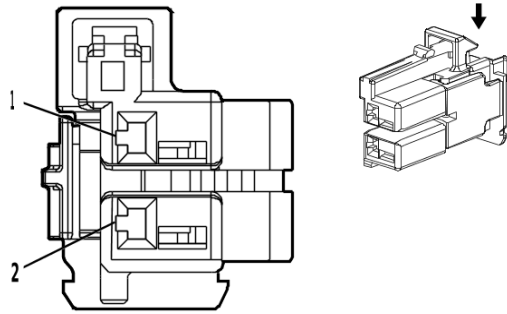

4672650

**Connector Part Information**

Harness Type: Automatic Transmission Wiring Harness - Control  
 OEM Connector: 2289523-1  
 Service Connector: Service by Harness - See Part Catalog  
 Description: 2-Way F 1.2 MCON Series( BN)

**Terminal Part Information**

Terminal Type ID	Terminated Lead	Diagnostic Test Probe	Terminal Removal Tool
I	Not required	J-35616-12 (BU)	No Tool Required

**Q77F Transmission Control Solenoid Valve 6 (MHS / MQC)**

Pin	Size	Color	Circuit	Function	Terminal Type ID	Option
1	0.5	WH	6388	Transmission High Side Driver 2 Control	I	—
2	0.5	BU / GY	4508	Transmission Clutch G Control	I	—

**Q77F Transmission Control Solenoid Valve 6 (MHT / MI2 / MQB)**

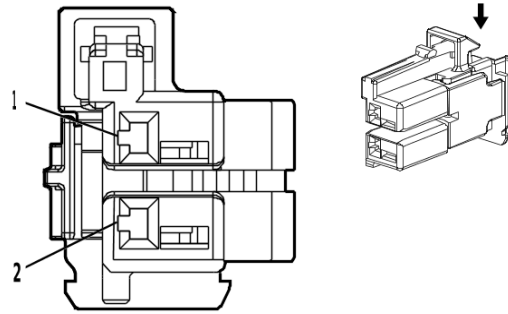

4672650

**Connector Part Information**

Harness Type: Automatic Transmission Wiring Harness - Control  
 OEM Connector: 2289523-1  
 Service Connector: Service by Harness - See Part Catalog  
 Description: 2-Way F 1.2 MCON Series( BN)

**Terminal Part Information**

Terminal Type ID	Terminated Lead	Diagnostic Test Probe	Terminal Removal Tool
I	Not required	J-35616-12 (BU)	No Tool Required

**Q77F Transmission Control Solenoid Valve 6 (MHT / MI2 / MQB)**

Pin	Size	Color	Circuit	Function	Terminal Type ID	Option
1	0.5	WH	6388	Transmission High Side Driver 2 Control	I	—
2	0.5	BU / GY	4508	Transmission Clutch G Control	I	—

**Q77F Transmission Control Solenoid Valve 6 (MQE)**

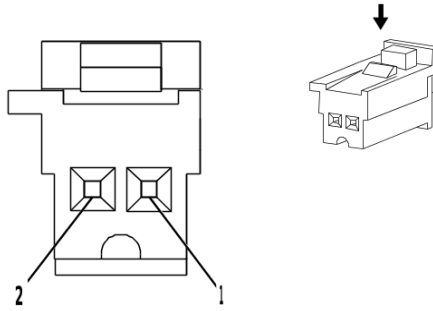

4051391

**Connector Part Information**

Harness Type: Automatic Transmission Wiring Harness - Control  
 OEM Connector: 13956948  
 Service Connector: Service by Harness - See Part Catalog  
 Description: 2-Way F 0.64 MTS Series( VT)

**Terminal Part Information**

Terminal Type ID	Terminated Lead	Diagnostic Test Probe	Terminal Removal Tool
I	Not required	J-35616-64B (L-BU)	No Tool Required

**Q77F Transmission Control Solenoid Valve 6 (MQE)**

Pin	Size	Color	Circuit	Function	Terminal Type ID	Option
1	0.5	GY / GN	1530	Transmission Line Pressure Control Solenoid Valve Control	I	—
2	0.5	GY / BN	6388	Transmission High Side Driver 2 Control	I	—

**Q77G Transmission Control Solenoid Valve 7 (MHS / MQC)**

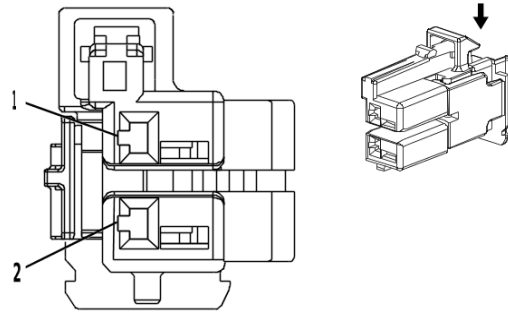

4364736

**Connector Part Information**

Harness Type: Automatic Transmission Wiring Harness - Control Extension  
 OEM Connector: 2289523-2  
 Service Connector: Service by Harness - See Part Catalog  
 Description: 2-Way F 1.2 MCON Series( BU)

**Terminal Part Information**

Terminal Type ID	Terminated Lead	Diagnostic Test Probe	Terminal Removal Tool
I	Not required	J-35616-12 (BU)	No Tool Required

**Q77G Transmission Control Solenoid Valve 7 (MHS / MQC)**

Pin	Size	Color	Circuit	Function	Terminal Type ID	Option
1	0.5	BN	6387	Transmission High Side Driver 1 Control	I	—
2	0.5	GN / OG	1530	Transmission Line Pressure Control Solenoid Valve Control	I	—

**Q77G Transmission Control Solenoid Valve 7 (MHT / MI2 / MQB)**

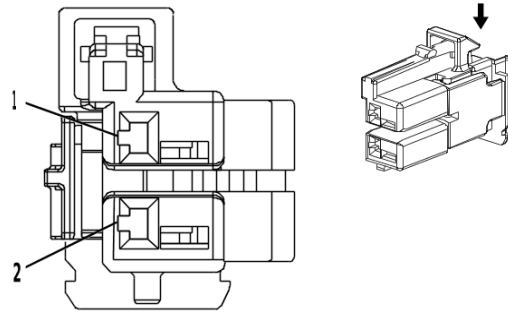

4364736

**Connector Part Information**

Harness Type: Automatic Transmission Wiring Harness - Control Extension  
 OEM Connector: 2289523-2  
 Service Connector: Service by Harness - See Part Catalog  
 Description: 2-Way F 1.2 MCON Series( BU)

**Terminal Part Information**

Terminal Type ID	Terminated Lead	Diagnostic Test Probe	Terminal Removal Tool
I	Not required	J-35616-12 (BU)	No Tool Required

**Q77G Transmission Control Solenoid Valve 7 (MHT / MI2 / MQB)**

Pin	Size	Color	Circuit	Function	Terminal Type ID	Option
1	0.5	BN	6387	Transmission High Side Driver 1 Control	I	—
2	0.5	GN / OG	1530	Transmission Line Pressure Control Solenoid Valve Control	I	—



**Q77G Transmission Control Solenoid Valve 7 (MQE)**

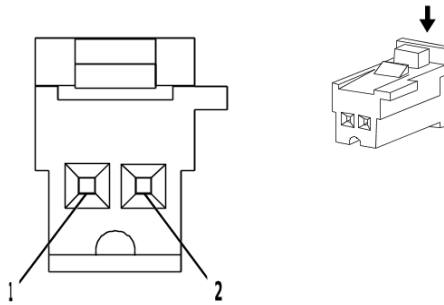

4008644

**Connector Part Information**

Harness Type: Automatic Transmission Wiring Harness - Control  
 OEM Connector: 13941672  
 Service Connector: Service by Harness - See Part Catalog  
 Description: 2-Way F 0.64 MTS Series( GY)

**Terminal Part Information**

Terminal Type ID	Terminated Lead	Diagnostic Test Probe	Terminal Removal Tool
I	Not required	J-35616-64B (L-BU)	No Tool Required

**Q77G Transmission Control Solenoid Valve 7 (MQE)**

Pin	Size	Color	Circuit	Function	Terminal Type ID	Option
1	0.5	YE / BN	422	Torque Converter Clutch Solenoid Valve Control	I	—
2	0.5	GY / BN	6388	Transmission High Side Driver 2 Control	I	—

**Q77H Transmission Control Solenoid Valve 8 (MHS / MQC)**

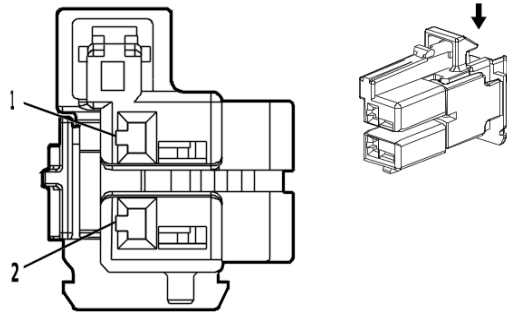

4672683

**Connector Part Information**

Harness Type: Automatic Transmission Wiring Harness - Control Extension  
 OEM Connector: 2289523-3  
 Service Connector: Service by Harness - See Part Catalog  
 Description: 2-Way F 1.2 MCON Series( GN)

**Terminal Part Information**

Terminal Type ID	Terminated Lead	Diagnostic Test Probe	Terminal Removal Tool
I	Not required	J-35616-12 (BU)	No Tool Required

**Q77H Transmission Control Solenoid Valve 8 (MHS / MQC)**

Pin	Size	Color	Circuit	Function	Terminal Type ID	Option
1	0.5	BN	6387	Transmission High Side Driver 1 Control	I	—
2	0.5	GY / BN	422	Torque Converter Clutch Solenoid Valve Control	I	—

**Q77H Transmission Control Solenoid Valve 8 (MHT / MI2 / MQB)**

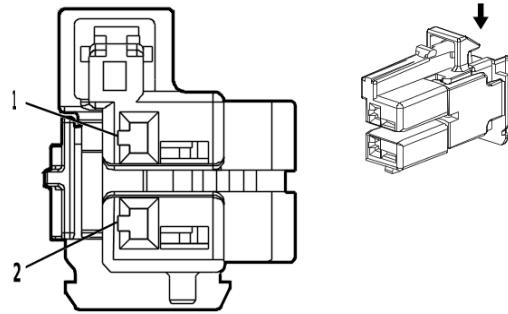

4672683

**Connector Part Information**

Harness Type: Automatic Transmission Wiring Harness - Control Extension  
 OEM Connector: 2289523-3  
 Service Connector: Service by Harness - See Part Catalog  
 Description: 2-Way F 1.2 MCON Series( GN)

**Terminal Part Information**

Terminal Type ID	Terminated Lead	Diagnostic Test Probe	Terminal Removal Tool
I	Not required	J-35616-12 (BU)	No Tool Required

**Q77H Transmission Control Solenoid Valve 8 (MHT / MI2 / MQB)**

Pin	Size	Color	Circuit	Function	Terminal Type ID	Option
1	0.5	BN	6387	Transmission High Side Driver 1 Control	I	—
2	0.5	GY / BN	422	Torque Converter Clutch Solenoid Valve Control	I	—

**Q77H Transmission Control Solenoid Valve 8 (MQE)**

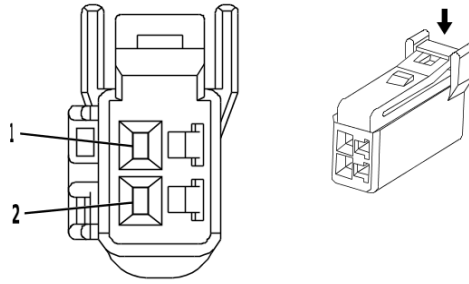

4051682

**Connector Part Information**

Harness Type: Automatic Transmission Wiring Harness - Control  
 OEM Connector: 7287-0122  
 Service Connector: Service by Harness - See Part Catalog  
 Description: 2-Way F 040 III Series( NA)

**Terminal Part Information**

Terminal Type ID	Terminated Lead	Diagnostic Test Probe	Terminal Removal Tool
I	Not required	J-35616-16 (L-GN)	No Tool Required

**Q77H Transmission Control Solenoid Valve 8 (MQE)**

Pin	Size	Color	Circuit	Function	Terminal Type ID	Option
1	0.5	GN / GY	6387	Transmission High Side Driver 1 Control	I	—
2	0.5	GN / WH	6380	Torque Converter Clutch Enable Solenoid Valve A Control	I	—

**Q77J Transmission Control Solenoid Valve 9 (MHS / MQC)**

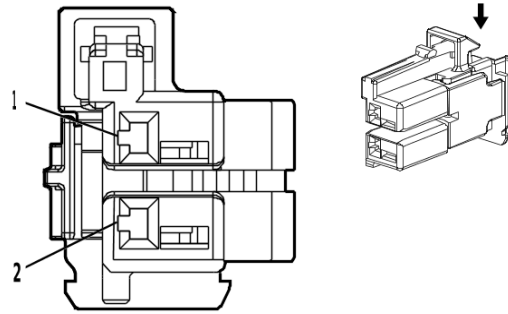

4672650

**Connector Part Information**

Harness Type: Automatic Transmission Wiring Harness - Control Extension  
 OEM Connector: 2289523-1  
 Service Connector: Service by Harness - See Part Catalog  
 Description: 2-Way F 1.2 MCON Series( BN)

**Terminal Part Information**

Terminal Type ID	Terminated Lead	Diagnostic Test Probe	Terminal Removal Tool
I	Not required	J-35616-12 (BU)	No Tool Required

**Q77J Transmission Control Solenoid Valve 9 (MHS / MQC)**

Pin	Size	Color	Circuit	Function	Terminal Type ID	Option
1	0.5	WH	6388	Transmission High Side Driver 2 Control	I	—
2	0.5	VT	7819	Default Disable Solenoid Control	I	—

**Q77J Transmission Control Solenoid Valve 9 (MHT / MI2 / MQB)**

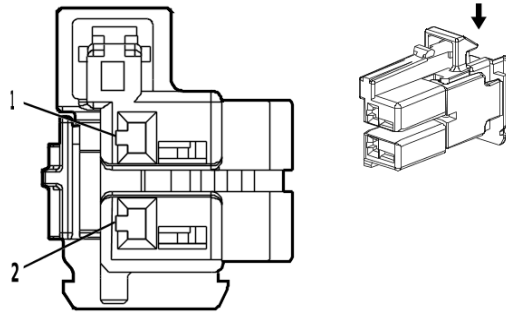

4672650

**Connector Part Information**

Harness Type: Automatic Transmission Wiring Harness - Control Extension  
 OEM Connector: 2289523-1  
 Service Connector: Service by Harness - See Part Catalog  
 Description: 2-Way F 1.2 MCON Series( BN)

**Terminal Part Information**

Terminal Type ID	Terminated Lead	Diagnostic Test Probe	Terminal Removal Tool
I	Not required	J-35616-12 (BU)	No Tool Required

**Q77J Transmission Control Solenoid Valve 9 (MHT / MI2 / MQB)**

Pin	Size	Color	Circuit	Function	Terminal Type ID	Option
1	0.5	WH	6388	Transmission High Side Driver 2 Control	I	—
2	0.5	VT	7819	Default Disable Solenoid Control	I	—

**Q77J Transmission Control Solenoid Valve 9 (MQE)**

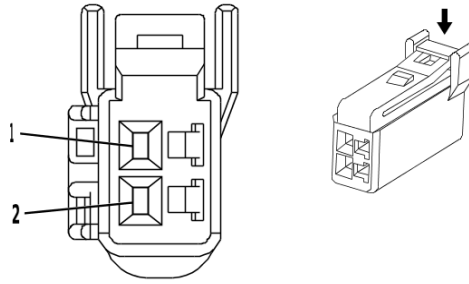

4051682

**Connector Part Information**

Harness Type: Automatic Transmission Wiring Harness - Control  
 OEM Connector: 7287-0122  
 Service Connector: Service by Harness - See Part Catalog  
 Description: 2-Way F 040 III Series( NA)

**Terminal Part Information**

Terminal Type ID	Terminated Lead	Diagnostic Test Probe	Terminal Removal Tool
I	Not required	J-35616-16 (L-GN)	No Tool Required

**Q77J Transmission Control Solenoid Valve 9 (MQE)**

Pin	Size	Color	Circuit	Function	Terminal Type ID	Option
1	0.5	YE / BN	6388	Transmission High Side Driver 2 Control	I	—
2	0.5	GY / BN	6210	Torque Converter Clutch Enable Solenoid Valve B Control	I	—

**Q83AA Valve Lifter Oil Solenoid Valve - Cylinder 1 (L84 / L87)**

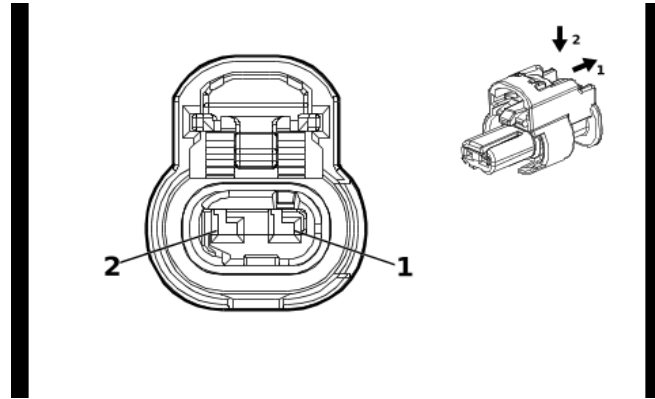

4036662

**Connector Part Information**

Harness Type: Valve Rocker Arm Oil Control Valve Harness  
 OEM Connector: 1-2296704-1  
 Service Connector: Service by Harness - See Part Catalog  
 Description: 2-Way F 1.2 MCON-CB Series, Sealed( BK)

**Terminal Part Information**

Terminal Type ID	Terminated Lead	Diagnostic Test Probe	Terminal Removal Tool
I	Not required	J-35616-16 (L-GN)	No Tool Required

**Q83AA Valve Lifter Oil Solenoid Valve - Cylinder 1 (L84 / L87)**

Pin	Size	Color	Circuit	Function	Terminal Type ID	Option
1	0.5	WH / BU	2491	Cylinder Shutoff Solenoid Enable Signal 1	I	—
2	0.5	BU	5491	Cylinder Deactivation Solenoid Valve Control 1	I	—



**Q83AB Valve Lifter Oil Solenoid Valve - Cylinder 2 (L84 / L87)**

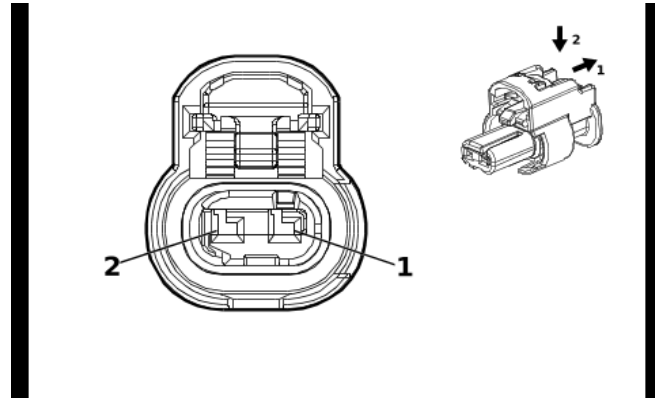

4036662

**Connector Part Information**

Harness Type: Valve Rocker Arm Oil Control Valve Harness  
 OEM Connector: 1-2296704-1  
 Service Connector: Service by Harness - See Part Catalog  
 Description: 2-Way F 1.2 MCON-CB Series, Sealed( BK)

**Terminal Part Information**

Terminal Type ID	Terminated Lead	Diagnostic Test Probe	Terminal Removal Tool
I	Not required	J-35616-16 (L-GN)	No Tool Required

**Q83AB Valve Lifter Oil Solenoid Valve - Cylinder 2 (L84 / L87)**

Pin	Size	Color	Circuit	Function	Terminal Type ID	Option
1	0.5	WH / GN	2492	Cylinder Shutoff Solenoid Enable Signal 2	I	—
2	0.5	GN	5492	Cylinder Deactivation Solenoid Valve Control 2	I	—

**Q83AC Valve Lifter Oil Solenoid Valve - Cylinder 3 (L84 / L87)**

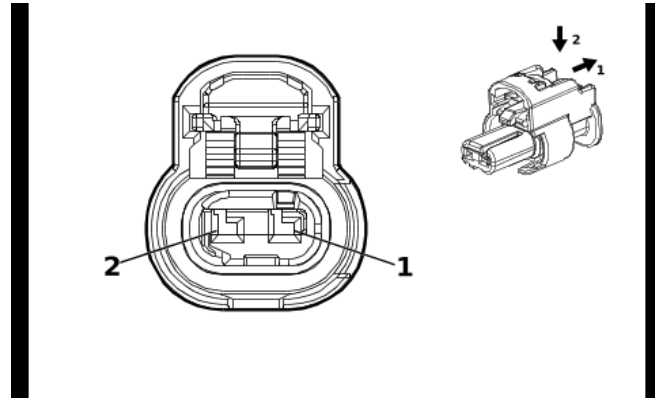

4036662

**Connector Part Information**

Harness Type: Valve Rocker Arm Oil Control Valve Harness  
 OEM Connector: 1-2296704-1  
 Service Connector: Service by Harness - See Part Catalog  
 Description: 2-Way F 1.2 MCON-CB Series, Sealed( BK)

**Terminal Part Information**

Terminal Type ID	Terminated Lead	Diagnostic Test Probe	Terminal Removal Tool
I	Not required	J-35616-16 (L-GN)	No Tool Required

**Q83AC Valve Lifter Oil Solenoid Valve - Cylinder 3 (L84 / L87)**

Pin	Size	Color	Circuit	Function	Terminal Type ID	Option
1	0.5	YE / GY	2493	Cylinder Shutoff Solenoid Enable Signal 3	I	—
2	0.5	GY	5493	Cylinder Deactivation Solenoid Valve Control 3	I	—

**Q83AD Valve Lifter Oil Solenoid Valve - Cylinder 4 (L84 / L87)**

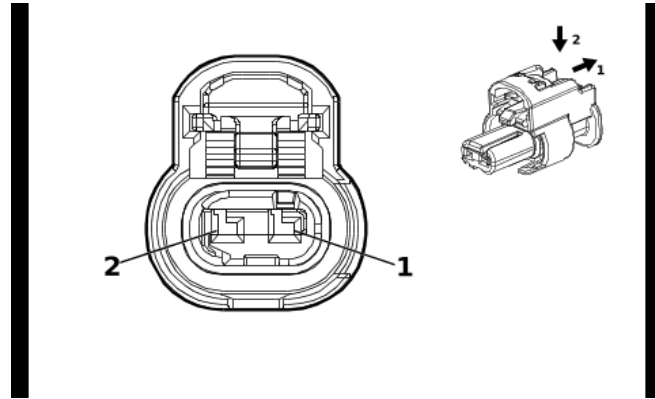

4036662

**Connector Part Information**

Harness Type: Valve Rocker Arm Oil Control Valve Harness  
 OEM Connector: 1-2296704-1  
 Service Connector: Service by Harness - See Part Catalog  
 Description: 2-Way F 1.2 MCON-CB Series, Sealed( BK)

**Terminal Part Information**

Terminal Type ID	Terminated Lead	Diagnostic Test Probe	Terminal Removal Tool
I	Not required	J-35616-16 (L-GN)	No Tool Required

**Q83AD Valve Lifter Oil Solenoid Valve - Cylinder 4 (L84 / L87)**

Pin	Size	Color	Circuit	Function	Terminal Type ID	Option
1	0.5	YE / GN	2494	Cylinder Shutoff Solenoid Enable Signal 4	I	—
2	0.5	YE / BU	5494	Cylinder Deactivation Solenoid Valve Control 4	I	—

**Q83AE Valve Lifter Oil Solenoid Valve - Cylinder 5 (L84 / L87)**

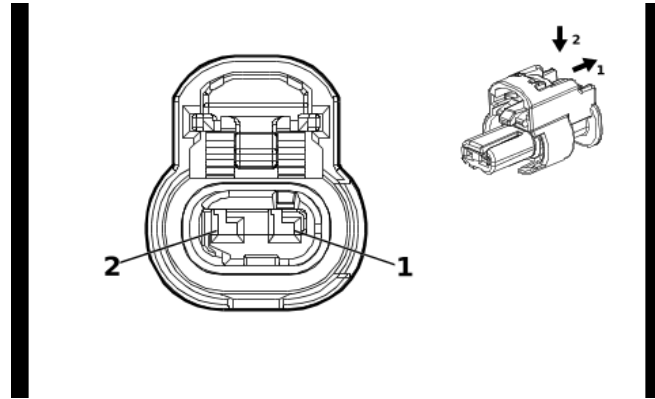

4036662

**Connector Part Information**

Harness Type: Valve Rocker Arm Oil Control Valve Harness  
 OEM Connector: 1-2296704-1  
 Service Connector: Service by Harness - See Part Catalog  
 Description: 2-Way F 1.2 MCON-CB Series, Sealed( BK)

**Terminal Part Information**

Terminal Type ID	Terminated Lead	Diagnostic Test Probe	Terminal Removal Tool
I	Not required	J-35616-16 (L-GN)	No Tool Required

**Q83AE Valve Lifter Oil Solenoid Valve - Cylinder 5 (L84 / L87)**

Pin	Size	Color	Circuit	Function	Terminal Type ID	Option
1	0.5	WH / VT	2495	Cylinder Shutoff Solenoid Enable Signal 5	I	—
2	0.5	VT	5495	Cylinder Deactivation Solenoid Valve Control 5	I	—

**Q83AF Valve Lifter Oil Solenoid Valve - Cylinder 6 (L84 / L87)**

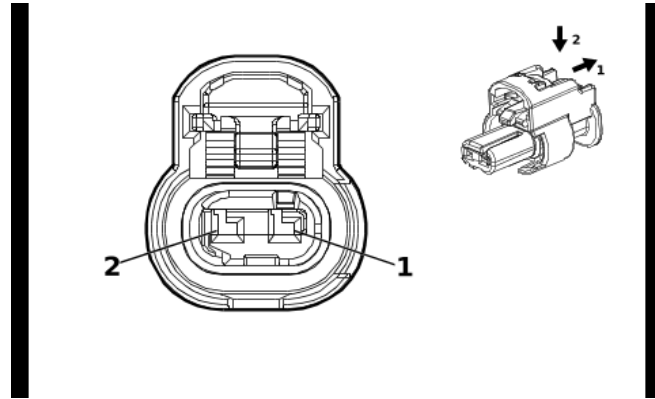

4036662

**Connector Part Information**

Harness Type: Valve Rocker Arm Oil Control Valve Harness  
 OEM Connector: 1-2296704-1  
 Service Connector: Service by Harness - See Part Catalog  
 Description: 2-Way F 1.2 MCON-CB Series, Sealed( BK)

**Terminal Part Information**

Terminal Type ID	Terminated Lead	Diagnostic Test Probe	Terminal Removal Tool
I	Not required	J-35616-16 (L-GN)	No Tool Required

**Q83AF Valve Lifter Oil Solenoid Valve - Cylinder 6 (L84 / L87)**

Pin	Size	Color	Circuit	Function	Terminal Type ID	Option
1	0.5	YE / BN	2496	Cylinder Shutoff Solenoid Enable Signal 6	I	—
2	0.5	BN	5496	Cylinder Deactivation Solenoid Valve Control 6	I	—

**Q83AG Valve Lifter Oil Solenoid Valve - Cylinder 7 (L84 / L87)**

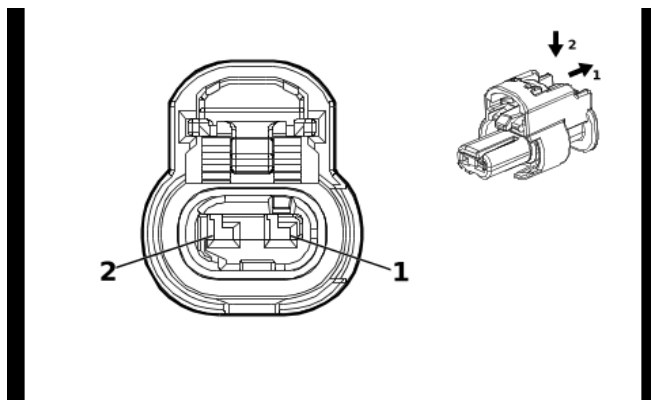

4036662

**Connector Part Information**

Harness Type: Valve Rocker Arm Oil Control Valve Harness  
 OEM Connector: 1-2296704-1  
 Service Connector: Service by Harness - See Part Catalog  
 Description: 2-Way F 1.2 MCON-CB Series, Sealed( BK)

**Terminal Part Information**

Terminal Type ID	Terminated Lead	Diagnostic Test Probe	Terminal Removal Tool
I	Not required	J-35616-16 (L-GN)	No Tool Required

**Q83AG Valve Lifter Oil Solenoid Valve - Cylinder 7 (L84 / L87)**

Pin	Size	Color	Circuit	Function	Terminal Type ID	Option
1	0.5	GN / GY	2497	Cylinder Shutoff Solenoid Enable Signal 7	I	—
2	0.5	WH	5497	Cylinder Deactivation Solenoid Valve Control 7	I	—

**Q83AH Valve Lifter Oil Solenoid Valve - Cylinder 8 (L84 / L87)**

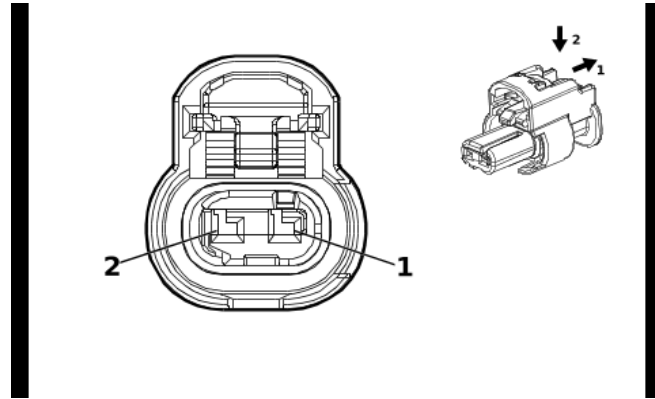

4036662

**Connector Part Information**

Harness Type: Valve Rocker Arm Oil Control Valve Harness  
 OEM Connector: 1-2296704-1  
 Service Connector: Service by Harness - See Part Catalog  
 Description: 2-Way F 1.2 MCON-CB Series, Sealed( BK)

**Terminal Part Information**

Terminal Type ID	Terminated Lead	Diagnostic Test Probe	Terminal Removal Tool
I	Not required	J-35616-16 (L-GN)	No Tool Required

**Q83AH Valve Lifter Oil Solenoid Valve - Cylinder 8 (L84 / L87)**

Pin	Size	Color	Circuit	Function	Terminal Type ID	Option
1	0.5	WH / YE	2498	Cylinder Shutoff Solenoid Enable Signal 8	I	—
2	0.5	YE	5498	Cylinder Deactivation Solenoid Valve Control 8	I	—

**Q97B Engine Coolant Flow Control Valve - Block**

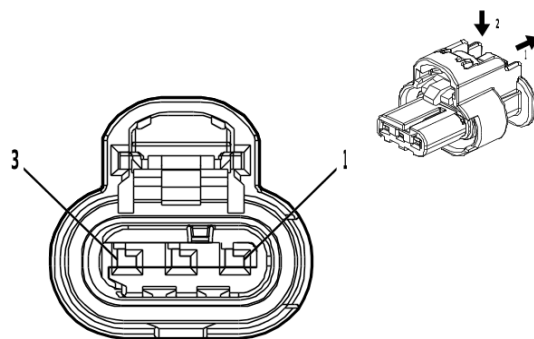

4778903

**Connector Part Information**

Harness Type: Engine Wiring Harness  
 OEM Connector: 1-2296695-2  
 Service Connector: 86792095  
 Description: 3-Way F 1.2 MCON-CB Series, Sealed( BK)

**Terminal Part Information**

Terminal Type ID	Terminated Lead	Diagnostic Test Probe	Terminal Removal Tool
I	Not required	J-35616-16 (L-GN)	No Tool Required

**Q97B Engine Coolant Flow Control Valve - Block**

Pin	Size	Color	Circuit	Function	Terminal Type ID	Option
1	0.5	GN / BN	2732	Engine Control Module LIN Bus 4	I	—
2	0.5	BK	6550	Ground	I	—
3	0.5	VT / BU	5294	Powertrain Main Relay Fused Supply Voltage 5	I	—



**Q97M Engine Coolant Flow Control Valve - Main**

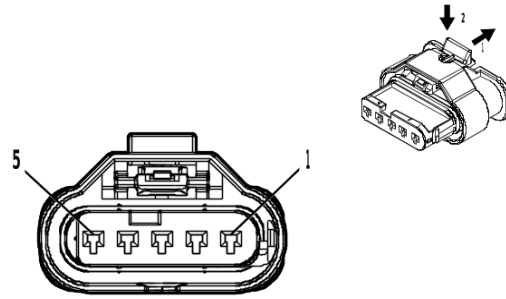

4994456

**Connector Part Information**

Harness Type: Engine Wiring Harness  
 OEM Connector: 2-2236898-5  
 Service Connector: 19371191  
 Description: 5-Way F 1.2 MCON-LL Series, Sealed( NA)

**Terminal Part Information**

Terminal Type ID	Terminated Lead	Diagnostic Test Probe	Terminal Removal Tool
I	Not required	J-35616-12 (BU)	No Tool Required

**Q97M Engine Coolant Flow Control Valve - Main**

Pin	Size	Color	Circuit	Function	Terminal Type ID	Option
1	0.75	GY / BN	2972	Coolant Flow Control Actuator Control Close	I	—
2	0.75	GY / BU	2971	Coolant Flow Control Actuator Control Open	I	—
3	0.5	BU / RD	460	Engine Control Sensors 5 Volt Reference 1	I	—
4	0.5	GY	2973	Coolant Flow Control Valve Position Signal	I	—
5	0.5	BK / YE	548	Engine Control Sensors Low Reference 1	I	—

**R6A Terminating Resistor - High Speed Bus**

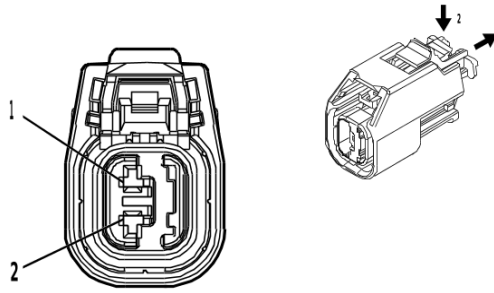

4889830

**Connector Part Information**

Harness Type: Rear Object Alarm Sensor Wiring Harness  
 OEM Connector: 33164011  
 Service Connector: Service by Harness - See Part Catalog  
 Description: 2-Way F 1.5 OCS Series, Sealed( BK)

**Terminal Part Information**

Terminal Type ID	Terminated Lead	Diagnostic Test Probe	Terminal Removal Tool
I	Not required	J-35616-14 (GN)	No Tool Required

**R6A Terminating Resistor - High Speed Bus**

Pin	Size	Color	Circuit	Function	Terminal Type ID	Option
1	0.5	WH	4100	AUTOSAR CAN Bus [-] 4 Serial Data	I	—
2	0.5	BU / VT	4101	AUTOSAR CAN Bus [+] 4 Serial Data	I	—

## R29 Fuel Filter (LM2)

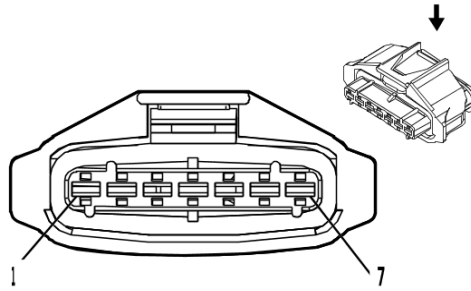

2537256

### Connector Part Information

Harness Type: Chassis Wiring Harness  
 OEM Connector: 10774827  
 Service Connector: 19354080  
 Description: 7-Way F 2.8 Junior Power Timer Series, Sealed( BK)

### Terminal Part Information

Terminal Type ID	Terminated Lead	Diagnostic Test Probe	Terminal Removal Tool
I	Not required	J-35616-35 (VT)	No Tool Required

### R29 Fuel Filter (LM2)

Pin	Size	Color	Circuit	Function	Terminal Type ID	Option
1	2.5	BK	1650	Ground	I	—
2	2.5	BN / YE	2996	Fuel Heater Control 1	I	—
3	1	VT / GN	4320	Powertrain Sensor Bus Enable	I	—
4	0.5	BK / BU	6863	Water In Fuel Sensor Low Reference	I	—
5	0.5	BU / YE	6861	Water In Fuel Sensor Signal	I	—
6	0.5	BN / GY	7072	Fuel Temperature Sensor 1 Signal	I	—
7	0.5	BN / WH	7073	Fuel Temperature Sensor 1 Low Reference	I	—

**S2 Automatic Transmission Manual Shift Shaft Position Switch (IOK)**

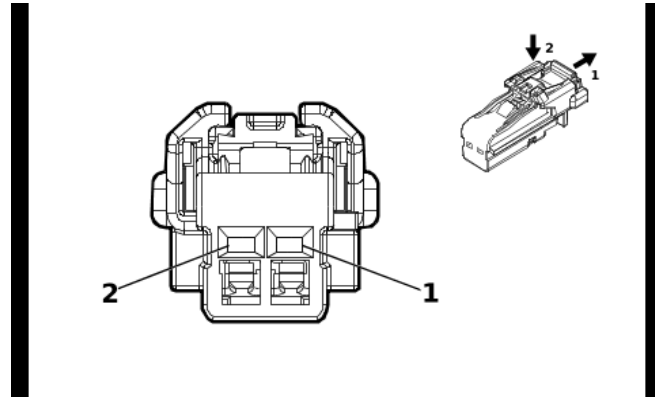

4115691

**Connector Part Information**

Harness Type: Instrument Panel Wiring Harness  
 OEM Connector: 6098-8988  
 Service Connector: 87816612  
 Description: 2-Way F 1.2 MCON Series( BK)

**Terminal Part Information**

Terminal Type ID	Terminated Lead	Diagnostic Test Probe	Terminal Removal Tool
I	Not required	J-35616-12 (BU)	No Tool Required
II	Not required	J-35616-16 (L-GN)	No Tool Required

**S2 Automatic Transmission Manual Shift Shaft Position Switch (IOK)**

Pin	Size	Color	Circuit	Function	Terminal Type ID	Option
1	0.35	GN / BU	3738	Tap Up/Tap Down Switch Signal 2	I	—
2	0.5	BK / WH	851	Signal Ground	II	—

**S2 Automatic Transmission Manual Shift Shaft Position Switch (MHT / MQB)**

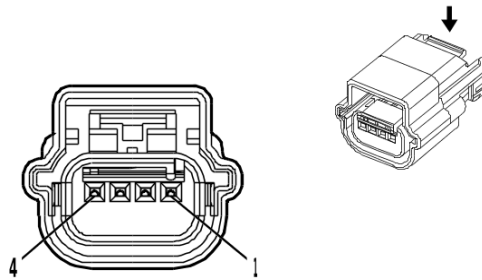

4789353

**Connector Part Information**

Harness Type: Automatic Transmission Wiring Harness - Case  
 OEM Connector: 6006314801  
 Service Connector: Service by Harness - See Part Catalog  
 Description: 4-Way F 0.64 Series, Sealed( BK)

**Terminal Part Information**

Terminal Type ID	Terminated Lead	Diagnostic Test Probe	Terminal Removal Tool
I	Not required	J-35616-64B (L-BU)	No Tool Required

**S2 Automatic Transmission Manual Shift Shaft Position Switch (MHT / MQB)**

Pin	Size	Color	Circuit	Function	Terminal Type ID	Option
1	0.5	BK / GY	626	Engine Control Vehicle Sensors Low Reference 1	I	—
2	0.5	YE	3338	Transmission Internal Mode Switch Mode Control X	I	—
3	0.5	YE / GY	3337	Transmission Internal Mode Switch Mode Control Y	I	—
4	0.5	OG	480	Engine Control Vehicle Sensors 5 Volt Reference 1	I	—

**S2 Automatic Transmission Manual Shift Shaft Position Switch (MQE)**

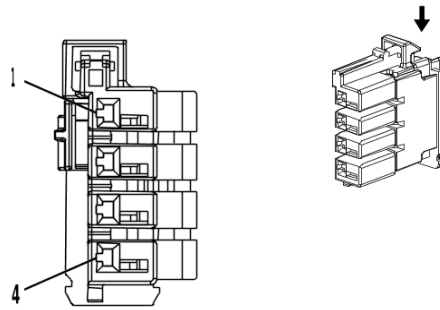

4364148

**Connector Part Information**

Harness Type: Automatic Transmission Wiring Harness - Control  
 OEM Connector: 2289524-1  
 Service Connector: Service by Harness - See Part Catalog  
 Description: 4-Way F 1.2 MCON Series( BN)

**Terminal Part Information**

Terminal Type ID	Terminated Lead	Diagnostic Test Probe	Terminal Removal Tool
I	Not required	J-35616-16 (L-GN)	No Tool Required

**S2 Automatic Transmission Manual Shift Shaft Position Switch (MQE)**

Pin	Size	Color	Circuit	Function	Terminal Type ID	Option
1	0.5	GN / YE	3337	Transmission Internal Mode Switch Mode Control Y	I	—
2	0.5	WH / RD	480	Engine Control Vehicle Sensors 5 Volt Reference 1	I	—
3	0.5	BK / GY	626	Engine Control Vehicle Sensors Low Reference 1	I	—
4	0.5	BU / WH	3338	Transmission Internal Mode Switch Mode Control X	I	—

### S3 Automatic Transmission Control

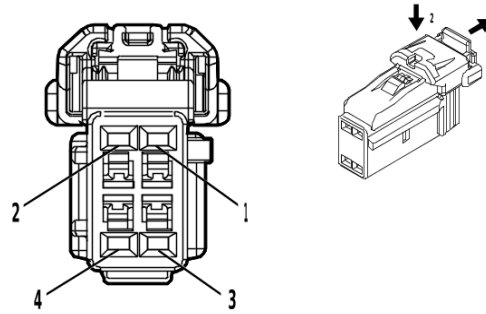

4872683

#### Connector Part Information

Harness Type: Instrument Panel Wiring Harness  
 OEM Connector: 6098-8435  
 Service Connector: 19369633  
 Description: 4-Way F 1.2 Series( BK)

#### Terminal Part Information

Terminal Type ID	Terminated Lead	Diagnostic Test Probe	Terminal Removal Tool
I	Not required	J-35616-12 (BU)	No Tool Required
II	Not required	J-35616-16 (L-GN)	No Tool Required

#### S3 Automatic Transmission Control

Pin	Size	Color	Circuit	Function	Terminal Type ID	Option
1	0.35	YE / WH	816	Brake Transmission Shift Interlock Solenoid Actuator Control	I	—
2	0.5	BK	1050	Ground	II	—
3	0.35	VT / BK	7553	Park Lock Solenoid Actuator Control	I	—
4	0.5	BK	1050	Ground	II	—

**S13D Door Lock Switch - Driver (- AEQ)**

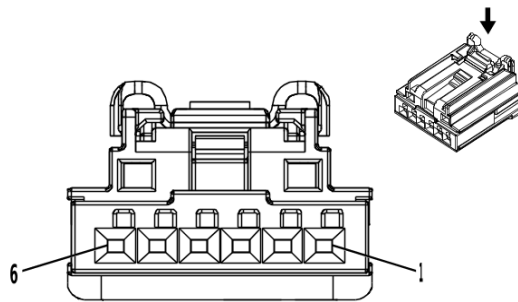

4145138

**Connector Part Information**

Harness Type: Front Side Door Door Lock Door Wiring Harness - Driver  
 OEM Connector: 2035363-2  
 Service Connector: Service by Harness - See Part Catalog  
 Description: 6-Way F 0.64 Generation Y Series( BK)

**Terminal Part Information**

Terminal Type ID	Terminated Lead	Diagnostic Test Probe	Terminal Removal Tool
I	Not required	J-35616-64B (L-BU)	No Tool Required

**S13D Door Lock Switch - Driver (- AEQ)**

Pin	Size	Color	Circuit	Function	Terminal Type ID	Option
1	0.5	BN / GY	4784	Left Front Door LED Backlight Dimming Control	I	—
2	—	—	—	Not Occupied	—	—
3	0.5	BN / YE	2771	Left Front Door Lock Switch Lock Signal	I	—
4	0.5	BN / WH	2772	Left Front Door Lock Switch Unlock Signal	I	—
5	0.5	BK	1550	Ground	I	—
6	—	—	—	Not Occupied	—	—



**S13D Door Lock Switch - Driver (AEQ)**

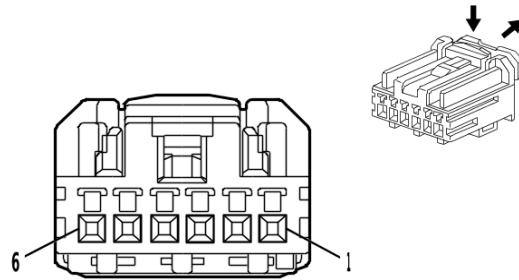

4650256

**Connector Part Information**

Harness Type: Front Side Door Door Lock Door Wiring Harness - Driver  
 OEM Connector: HCMPB-C06A-K  
 Service Connector: Service by Harness - See Part Catalog  
 Description: 6-Way F 0.64 HCM Series( BK)

**Terminal Part Information**

Terminal Type ID	Terminated Lead	Diagnostic Test Probe	Terminal Removal Tool
I	Not required	J-35616-64B (L-BU)	No Tool Required

**S13D Door Lock Switch - Driver (AEQ)**

Pin	Size	Color	Circuit	Function	Terminal Type ID	Option
1	0.5	BN / GY	4784	Left Front Door LED Backlight Dimming Control	I	—
	0.5	YE	6817	LED Backlight Dimming Control 1		—
2	0.5	BN / YE	2771	Left Front Door Lock Switch Lock Signal	I	—
3	0.5	BN / WH	2772	Left Front Door Lock Switch Unlock Signal	I	—
4	0.5	BK	1550	Ground	I	—
5 - 6	—	—	—	Not Occupied	—	—

**S13P Door Lock Switch - Passenger - Double Cab / Crew Cab (GF2 / GF5 / GFF / GPZ)**

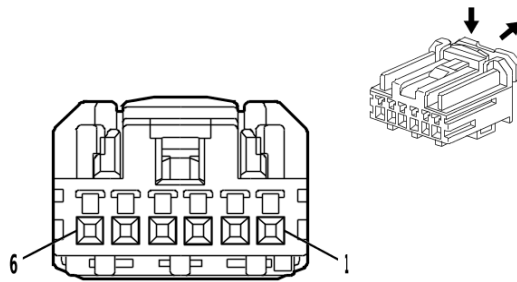

4650256

**Connector Part Information**

Harness Type: Front Side Door Door Lock Door Wiring Harness - Passenger  
 OEM Connector: HCMPB-C06A-K  
 Service Connector: Service by Harness - See Part Catalog  
 Description: 6-Way F 0.64 HCM Series( BK)

**Terminal Part Information**

Terminal Type ID	Terminated Lead	Diagnostic Test Probe	Terminal Removal Tool
I	Not required	J-35616-64B (L-BU)	No Tool Required

**S13P Door Lock Switch - Passenger - Double Cab / Crew Cab (GF2 / GF5 / GFF / GPZ)**

Pin	Size	Color	Circuit	Function	Terminal Type ID	Option
1	0.5	YE	6817	LED Backlight Dimming Control 1	I	DEN DLF/ DPO
	0.5	GY / VT	4638	LED Backlight Dimming Control Right Front Door	I	
2	0.5	YE / VT	2773	Right Front Door Lock Switch Lock Control	I	—
3	0.5	BN / VT	2774	Right Front Door Lock Switch Unlock Control	I	—
4	0.5	BK	1350	Ground	I	—
5 - 6	—	—	—	Not Occupied	—	—

**S13P Door Lock Switch - Passenger - Double Cab / Crew Cab (GF3 / GF4 / GFC / GRZ)**

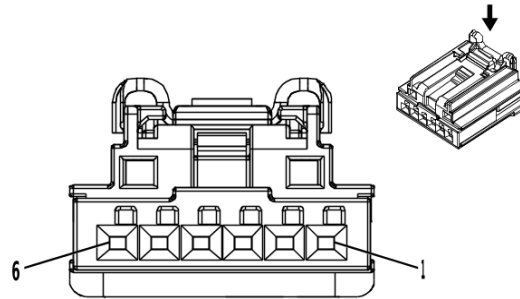

4145138

**Connector Part Information**

Harness Type: Front Side Door Door Lock Door Wiring Harness - Passenger  
 OEM Connector: 2035363-2  
 Service Connector: Service by Harness - See Part Catalog  
 Description: 6-Way F 0.64 Generation Y Series( BK)

**Terminal Part Information**

Terminal Type ID	Terminated Lead	Diagnostic Test Probe	Terminal Removal Tool
I	Not required	J-35616-64B (L-BU)	No Tool Required

**S13P Door Lock Switch - Passenger - Double Cab / Crew Cab (GF3 / GF4 / GFC / GRZ)**

Pin	Size	Color	Circuit	Function	Terminal Type ID	Option
1	0.5	GY / VT	4638	LED Backlight Dimming Control Right Front Door	I	—
2	—	—	—	Not Occupied	—	—
3	0.5	YE / VT	2773	Right Front Door Lock Switch Lock Control	I	—
4	0.5	BN / VT	2774	Right Front Door Lock Switch Unlock Control	I	—
5	0.5	BK	1350	Ground	I	—
6	—	—	—	Not Occupied	—	—

**S13P Door Lock Switch - Passenger - Regular Cab (GF3 / GF4 / GF5 / GFC)**

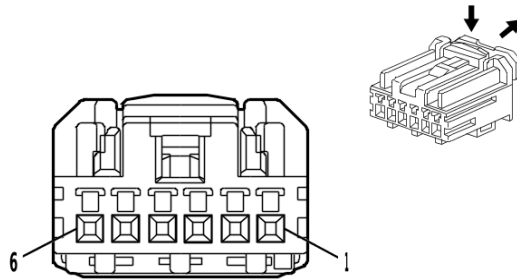

4650256

**Connector Part Information**

Harness Type: Front Side Door Door Lock Door Wiring Harness - Passenger  
 OEM Connector: HCMPB-C06A-K  
 Service Connector: Service by Harness - See Part Catalog  
 Description: 6-Way F 0.64 HCM Series( BK)

**Terminal Part Information**

Terminal Type ID	Terminated Lead	Diagnostic Test Probe	Terminal Removal Tool
I	Not required	J-35616-64B (L-BU)	No Tool Required

**S13P Door Lock Switch - Passenger - Regular Cab (GF3 / GF4 / GF5 / GFC)**

Pin	Size	Color	Circuit	Function	Terminal Type ID	Option
1	0.5	GY / VT	4638	LED Backlight Dimming Control Right Front Door	I	—
2	0.5	YE / VT	2773	Right Front Door Lock Switch Lock Control	I	—
3	0.5	BN / VT	2774	Right Front Door Lock Switch Unlock Control	I	—
4	0.5	BK	1350	Ground	I	—
5 - 6	—	—	—	Not Occupied	—	—

## S27 Head-Up Display Switch (UV6)

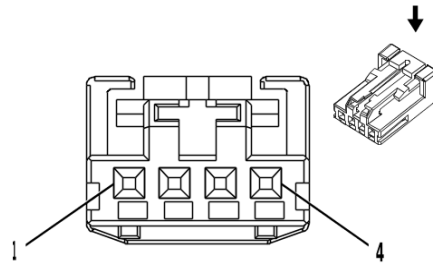

2717162

### Connector Part Information

Harness Type: Instrument Panel Wiring Harness  
 OEM Connector: 1-936119-1  
 Service Connector: 19367524  
 Description: 4-Way F 0.64 Micro-Quadlock Series( BK)

### Terminal Part Information

Terminal Type ID	Terminated Lead	Diagnostic Test Probe	Terminal Removal Tool
I	Not required	J-35616-64B (L-BU)	No Tool Required

### S27 Head-Up Display Switch (UV6)

Pin	Size	Color	Circuit	Function	Terminal Type ID	Option
1	0.35	YE	6817	LED Backlight Dimming Control 1	I	—
2	0.35	BK / WH	851	Signal Ground	I	—
3	0.35	BK / GN	5699	Head-Up Display Switch Low Reference	I	—
4	0.35	YE / WH	622	Head-Up Display Switch Signal	I	—

### S30 Headlamp Switch

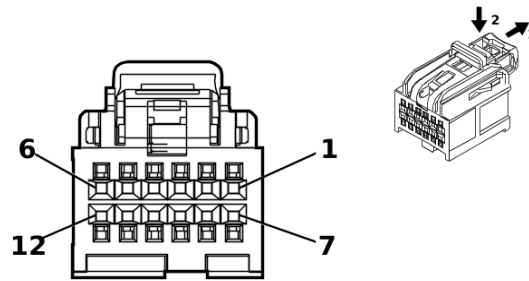

4975223

#### Connector Part Information

Harness Type: Instrument Panel Wiring Harness  
 OEM Connector: 35016616  
 Service Connector: 13519750  
 Description: 12-Way F 0.64 OCS Series( BK)

#### Terminal Part Information

Terminal Type ID	Terminated Lead	Diagnostic Test Probe	Terminal Removal Tool
I	19300660	J-35616-64B (L-BU)	J-38125-215A

#### S30 Headlamp Switch

Pin	Size	Color	Circuit	Function	Terminal Type ID	Option
1	0.35	WH / VT	103	Headlamp Switch On Signal	I	—
2	0.35	YE	6817	LED Backlight Dimming Control 1	I	—
3	0.35	GN / BN	306	Headlamp Switch Off Signal	I	—
4	0.35	GY	158	Cargo Lamp Switch Signal	I	—
5	0.35	GN / GY	13	Headlamp Switch Park Lamp Signal	I	—
6	0.35	BU / GN	4248	Cargo Lamp Indicator Control	I	—
7	0.35	WH / GY	2935	Task Lamp Switch Signal	I	—
8	0.35	BK / WH	851	Signal Ground	I	—
9 - 10	—	—	—	Not Occupied	—	—
11	0.35	WH / BN	7555	Headlamp Switch Signal	I	—
12	0.35	YE	7556	Headlamp Switch Reference	I	—

**S32R Rear Seat Heater Switch (KA6)**

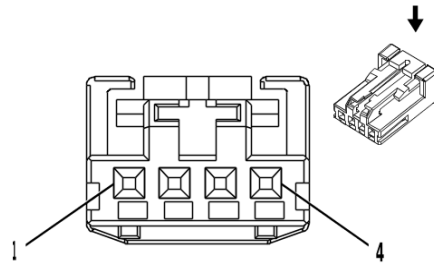

2717162

**Connector Part Information**

Harness Type: Front Floor Console Wiring Harness  
 OEM Connector: 13969166  
 Service Connector: Service by Harness - See Part Catalog  
 Description: 4-Way F 0.64 Micro-Quadlock Series( BK)

**Terminal Part Information**

Terminal Type ID	Terminated Lead	Diagnostic Test Probe	Terminal Removal Tool
I	Not required	No Tool Required	No Tool Required

**S32R Rear Seat Heater Switch (KA6)**

Pin	Size	Color	Circuit	Function	Terminal Type ID	Option
1	—	RD / BU	1240	Battery Positive Voltage	I	—
2	—	—	—	Not Occupied	—	—
3	—	GN / VT	2857	Body Control Module LIN Bus 11	I	—
4	—	BK / WH	1451	Signal Ground	I	—

**S33 Steering Wheel Horn Contact (D07 / NK5)**

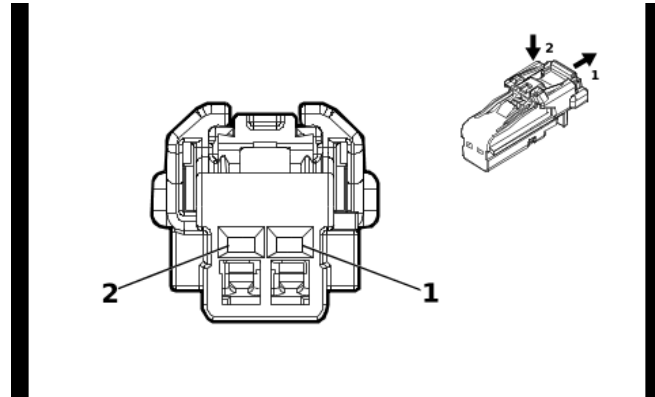

4115691

**Connector Part Information**

Harness Type: Steering Wheel Horn Switch Wiring Harness  
 OEM Connector: 13532422  
 Service Connector: Service by Harness - See Part Catalog  
 Description: 2-Way F 1.2 MCON Series( BK)

**Terminal Part Information**

Terminal Type ID	Terminated Lead	Diagnostic Test Probe	Terminal Removal Tool
I	Not required	J-35616-16 (L-GN)	No Tool Required

**S33 Steering Wheel Horn Contact (D07 / NK5)**

Pin	Size	Color	Circuit	Function	Terminal Type ID	Option
1	0.35	BK / WH	6051	Steering Wheel Ground	I	—
2	0.35	GN / WH	3287	Horn Switch Signal	I	—



**S33 Steering Wheel Horn Contact (N57 - D07)**

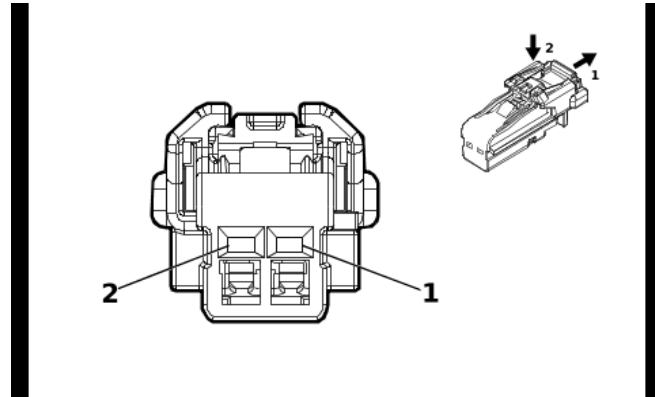

4115691

**Connector Part Information**

Harness Type: Steering Wheel Horn Switch Wiring Harness  
 OEM Connector: 13532422  
 Service Connector: Service by Harness - See Part Catalog  
 Description: 2-Way F 1.2 MCON Series( BK)

**Terminal Part Information**

Terminal Type ID	Terminated Lead	Diagnostic Test Probe	Terminal Removal Tool
I	Not required	J-35616-16 (L-GN)	No Tool Required

**S33 Steering Wheel Horn Contact (N57 - D07)**

Pin	Size	Color	Circuit	Function	Terminal Type ID	Option
1	0.35	BK	6051	Steering Wheel Ground	I	—
2	0.35	RD	3287	Horn Switch Signal	I	—

**S38 On/Off Vehicle Switch**

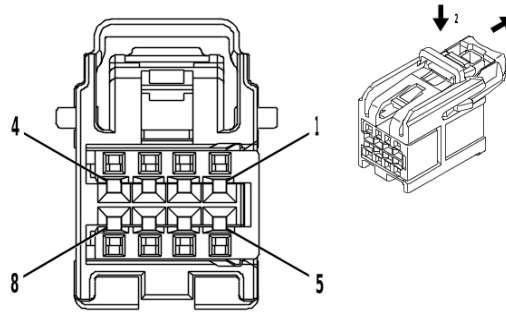

4232228

**Connector Part Information**

Harness Type: Instrument Panel Wiring Harness  
 OEM Connector: 15526973  
 Service Connector: 19353873  
 Description: 8-Way F 0.64 OCS Series( GY)

**Terminal Part Information**

Terminal Type ID	Terminated Lead	Diagnostic Test Probe	Terminal Removal Tool
I	Not required	J-35616-64B (L-BU)	No Tool Required

**S38 On/Off Vehicle Switch**

Pin	Size	Color	Circuit	Function	Terminal Type ID	Option
1	0.35	BU / BK	5719	Ignition Mode Switch Start LED Signal	I	—
2	0.35	BN / BK	5720	Ignition Mode Switch Accessory LED Signal	I	—
3	0.35	BK / WH	851	Signal Ground	I	—
4	0.35	BU / GN	5723	Ignition Mode Switch Mode Voltage	I	—
5	0.35	YE	6817	LED Backlight Dimming Control 1	I	—
6	—	—	—	Not Occupied	—	—
7	0.35	BK / GY	3559	Passive Start Switch 2 Low Reference	I	—
8	0.35	GN / BK	3558	Passive Start Switch Signal 2	I	—

**S47D Front Seat Adjuster Memory Switch - Driver - Cab / Crew Cab ((A45))**

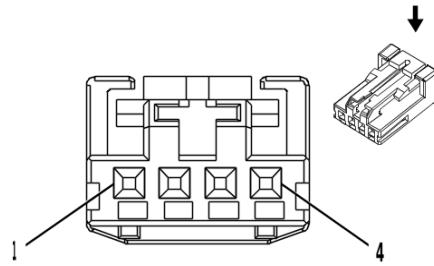

2717162

**Connector Part Information**

Harness Type: Front Side Door Door Lock Door Wiring Harness - Driver  
 OEM Connector: 1-936119-1  
 Service Connector: Service by Harness - See Part Catalog  
 Description: 4-Way F 0.64 Micro-Quadlock Series( BK)

**Terminal Part Information**

Terminal Type ID	Terminated Lead	Diagnostic Test Probe	Terminal Removal Tool
I	Not required	J-35616-64B (L-BU)	No Tool Required

**S47D Front Seat Adjuster Memory Switch - Driver - Cab / Crew Cab ((A45))**

Pin	Size	Color	Circuit	Function	Terminal Type ID	Option
1	0.5	BN / GY	4784	Left Front Door LED Backlight Dimming Control	I	—
2	0.5	BK / WH	1551	Signal Ground	I	—
3	0.5	WH	615	Seat Memory Switch Signal 1	I	—
4	0.5	BU / GN	614	Seat Memory Switch Set Signal	I	—

**S47D Front Seat Adjuster Memory Switch - Driver - Regular Cab ((A45))**

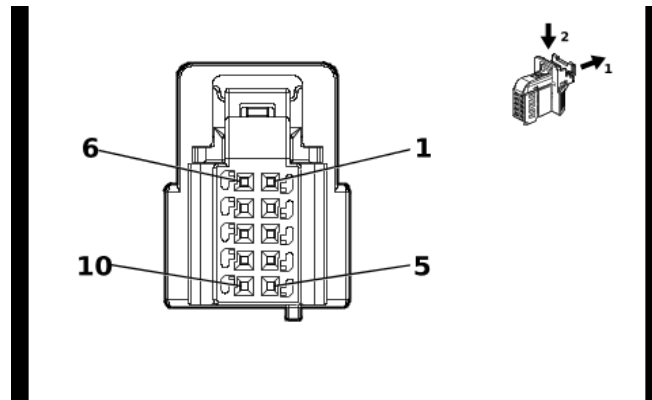

5838155

**Connector Part Information**

Harness Type: Front Side Door Door Lock Door Wiring Harness - Driver  
 OEM Connector: 2310000-1  
 Service Connector: Service by Harness - See Part Catalog  
 Description: 10-Way F 0.64 MQS Series( BK)

**Terminal Part Information**

Terminal Type ID	Terminated Lead	Diagnostic Test Probe	Terminal Removal Tool
I	Not required	J-35616-64B (L-BU)	No Tool Required

**S47D Front Seat Adjuster Memory Switch - Driver - Regular Cab ((A45))**

Pin	Size	Color	Circuit	Function	Terminal Type ID	Option
1	0.5	BN / GY	4784	Left Front Door LED Backlight Dimming Control	I	—
2	—	—	—	Not Occupied	—	—
3	0.5	BN / YE	2771	Left Front Door Lock Switch Lock Signal	I	—
4	0.5	BN / WH	2772	Left Front Door Lock Switch Unlock Signal	I	—
5	0.5	BK / WH	1551	Signal Ground	I	—
6	0.5	BU / GN	614	Seat Memory Switch Set Signal	I	—
7	0.5	WH	615	Seat Memory Switch Signal 1	I	—
8 - 10	—	—	—	Not Occupied	—	—

**S64D Front Seat Adjuster Switch - Driver (A45)**

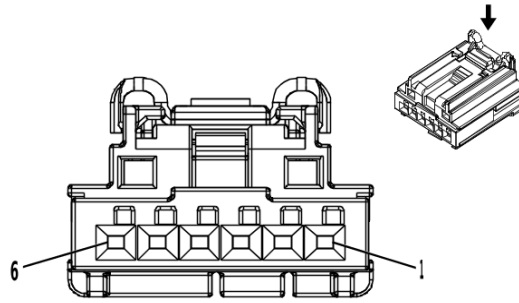

3960313

**Connector Part Information**

Harness Type: Front Seat Wiring Harness - Driver  
 OEM Connector: 2035363-4  
 Service Connector: Service by Harness - See Part Catalog  
 Description: 6-Way F 0.64 Generation Y Series( BK)

**Terminal Part Information**

Terminal Type ID	Terminated Lead	Diagnostic Test Probe	Terminal Removal Tool
I	Not required	J-35616-64B (L-BU)	No Tool Required

**S64D Front Seat Adjuster Switch - Driver (A45)**

Pin	Size	Color	Circuit	Function	Terminal Type ID	Option
1	0.5	RD / BN	2240	Battery Positive Voltage	I	—
2	—	—	—	Not Occupied	—	—
3	0.5 0.35	GN / GY	3758	Driver Seat Adjuster Memory Module LIN Bus 2	I	A45
		GN / GY	3758	Driver Seat Adjuster Memory Module LIN Bus 2		- A45
4	0.5	BK	1550	Ground	I	—
5	0.5	BU / YE	2818	Driver Seat Auxiliary Adjustment Switch Signal	I	—
6	0.5	BK / VT	2817	Auxiliary Driver Seat Adjustment Switch Low Reference	I	—

**S64D Front Seat Adjuster Switch - Driver (AZX - A45)**

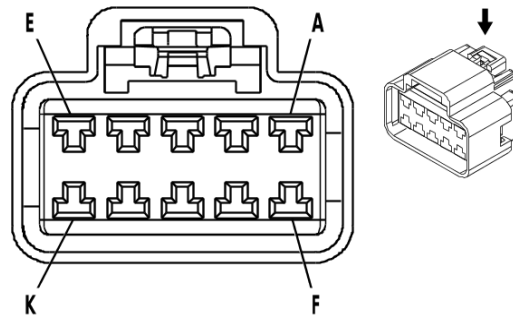

623046

**Connector Part Information**

Harness Type: Front Seat Wiring Harness - Driver  
 OEM Connector: 35058909  
 Service Connector: Service by Harness - See Part Catalog  
 Description: 10-Way F 280 GT Series( BK)

**Terminal Part Information**

Terminal Type ID	Terminated Lead	Diagnostic Test Probe	Terminal Removal Tool
I	Not required	J-35616-4A (PU)	No Tool Required

**S64D Front Seat Adjuster Switch - Driver (AZX - A45)**

Pin	Size	Color	Circuit	Function	Terminal Type ID	Option
A	2.5	RD / YE	5040	Battery Positive Voltage	I	—
B	1.5	BU / YE	277	Driver Seat Recline Motor Rearward Control	I	—
C	1.5	YE / BU	285	Driver Seat Horizontal Motor Forward Control	I	—
D	1.5	GY / GN	284	Driver Seat Horizontal Motor Rearward Control	I	—
E	1.5	GY / BU	283	Driver Seat Rear Vertical Motor Down Control	I	—
F	1.5	GN / BN	286	Driver Seat Front Vertical Motor Up Control	I	—
G	1.5	YE	282	Driver Seat Rear Vertical Motor Up Control	I	—
H	1.5	GN / YE	276	Driver Seat Recline Motor Forward Control	I	—
J	2.5	BK	1550	Ground	I	—
K	1.5	BU / VT	287	Driver Seat Front Vertical Motor Down Control	I	—

**S64P Front Seat Adjuster Switch - Passenger (A7K)**

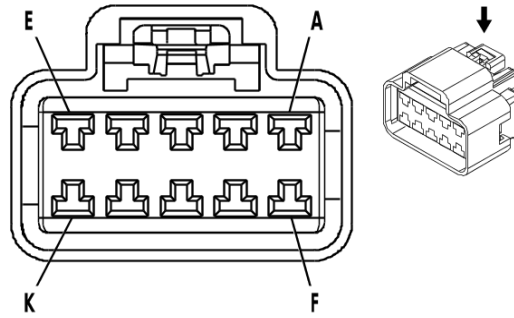

623046

**Connector Part Information**

Harness Type: Front Seat Wiring Harness - Passenger  
 OEM Connector: 35058909  
 Service Connector: Service by Harness - See Part Catalog  
 Description: 10-Way F 280 GT Series( BK)

**Terminal Part Information**

Terminal Type ID	Terminated Lead	Diagnostic Test Probe	Terminal Removal Tool
I	Not required	J-35616-4A (PU)	No Tool Required

**S64P Front Seat Adjuster Switch - Passenger (A7K)**

Pin	Size	Color	Circuit	Function	Terminal Type ID	Option
A	1.5	BU / WH	289	Passenger Seat Rear Vertical Motor Down Control	I	—
B	1.5	YE / BU	290	Passenger Seat Horizontal Motor Rearward Control	I	—
C	1.5	YE / WH	296	Passenger Seat Horizontal Motor Forward Control	I	—
D	1.5	BU / BN	77	Passenger Seat Recline Motor Rearward Control	I	—
E	2.5	BK	1350	Ground	I	—
F	1.5	GN / BU	298	Passenger Seat Front Vertical Motor Down Control	I	—
G	2.5	RD / GY	7440	Battery Positive Voltage	I	—
H	1.5	GN	76	Passenger Seat Recline Motor Forward Control	I	—
J	1.5	GN / WH	288	Passenger Seat Rear Vertical Motor Up Control	I	—
K	1.5	GN / VT	297	Passenger Seat Front Vertical Motor Up Control	I	—

**S65D Front Seat Lumbar Switch - Driver (AVK)**

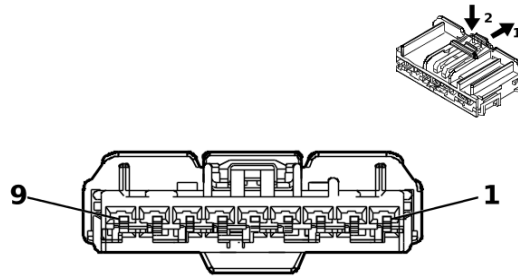

5204289

**Connector Part Information**

Harness Type: Front Seat Wiring Harness - Driver  
 OEM Connector: 7289-6875-40  
 Service Connector: Service by Harness - See Part Catalog  
 Description: 9-Way F 2.8 YESC Series( GY)

**Terminal Part Information**

Terminal Type ID	Terminated Lead	Diagnostic Test Probe	Terminal Removal Tool
I	Not required	J-35616-4A (PU)	No Tool Required

**S65D Front Seat Lumbar Switch - Driver (AVK)**

Pin	Size	Color	Circuit	Function	Terminal Type ID	Option
1	0.75	BK	1550	Ground	I	—
2	—	—	—	Not Occupied	—	—
3	0.75	RD / BN	2240	Battery Positive Voltage	I	—
4	—	—	—	Not Occupied	—	—
5	0.75	BU	611	Driver Seat Lumbar Support Motor Forward Control	I	—
6	—	—	—	Not Occupied	—	—
7	0.75	VT	610	Driver Seat Lumbar Support Motor Backward Control	I	—
8 - 9	—	—	—	Not Occupied	—	—



**S65P Front Seat Lumbar Switch - Passenger (- (AKE / AVU))**

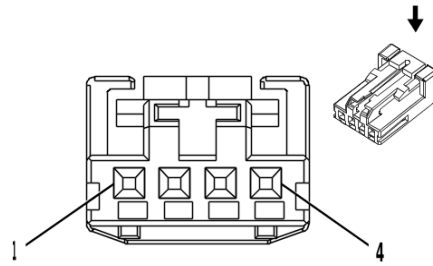

2717162

**Connector Part Information**

Harness Type: Front Seat Wiring Harness - Passenger  
 OEM Connector: 1-936119-1  
 Service Connector: Service by Harness - See Part Catalog  
 Description: 4-Way F 0.64 Micro-Quadlock Series( BK)

**Terminal Part Information**

Terminal Type ID	Terminated Lead	Diagnostic Test Probe	Terminal Removal Tool
I	Not required	J-35616-64B (L-BU)	No Tool Required

**S65P Front Seat Lumbar Switch - Passenger (- (AKE / AVU))**

Pin	Size	Color	Circuit	Function	Terminal Type ID	Option
1 - 2	—	—	—	Not Occupied	—	—
3	0.5	YE / GN	1068	Passenger Seat Lumbar Support Switch Analog Signal	I	—
4	0.5	BK / BU	2194	Passenger Seat Position Switch Low Reference	I	—

**S65P Front Seat Lumbar Switch - Passenger (A7K - AVU)**

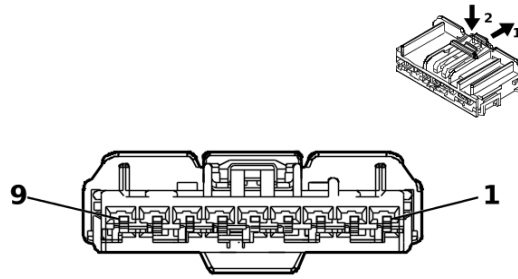

5204289

**Connector Part Information**

Harness Type: Front Seat Wiring Harness - Passenger  
 OEM Connector: 7289-6875-40  
 Service Connector: Service by Harness - See Part Catalog  
 Description: 9-Way F 2.8 YESC Series( GY)

**Terminal Part Information**

Terminal Type ID	Terminated Lead	Diagnostic Test Probe	Terminal Removal Tool
I	Not required	J-35616-4A (PU)	No Tool Required

**S65P Front Seat Lumbar Switch - Passenger (A7K - AVU)**

Pin	Size	Color	Circuit	Function	Terminal Type ID	Option
1	0.75	BK	1350	Ground	I	—
2	—	—	—	Not Occupied	—	—
3	0.75	RD / BN	2240	Battery Positive Voltage	I	—
4	—	—	—	Not Occupied	—	—
5	0.75	BU	211	Passenger Seat Lumbar Support Motor Forward Control	I	—
6	—	—	—	Not Occupied	—	—
7	0.75	VT	210	Passenger Seat Lumbar Support Motor Backward Control	I	—
8 - 9	—	—	—	Not Occupied	—	—

**S65P Front Seat Lumbar Switch - Passenger (AKE & AVU)**

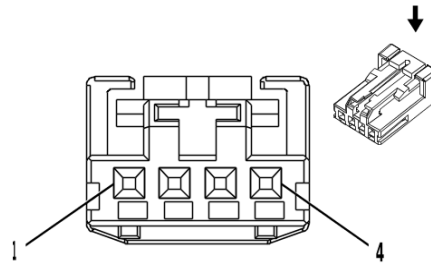

2717162

**Connector Part Information**

Harness Type: Front Seat Wiring Harness - Passenger  
 OEM Connector: 1-936119-1  
 Service Connector: Service by Harness - See Part Catalog  
 Description: 4-Way F 0.64 Micro-Quadlock Series( BK)

**Terminal Part Information**

Terminal Type ID	Terminated Lead	Diagnostic Test Probe	Terminal Removal Tool
I	Not required	J-35616-64B (L-BU)	No Tool Required

**S65P Front Seat Lumbar Switch - Passenger (AKE & AVU)**

Pin	Size	Color	Circuit	Function	Terminal Type ID	Option
1 - 2	—	—	—	Not Occupied	—	—
3	0.5	GN / WH	2816	Passenger Seat Auxiliary Adjustment Switch Signal	I	—
4	0.5	BK / BN	2815	Auxiliary Passenger Seat Adjustment Switch Low Reference	I	—

**S70E Radio Favorites Switch - Steering Wheel (D07 / NK5)**

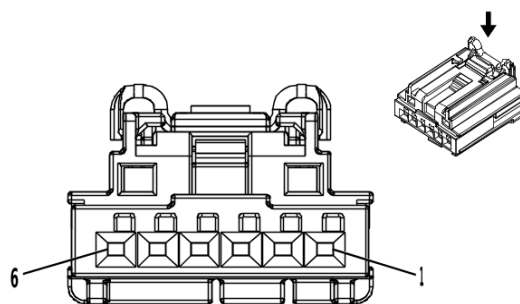

3960313

**Connector Part Information**

Harness Type: Steering Wheel Horn Switch Wiring Harness  
 OEM Connector: 13583825  
 Service Connector: Service by Harness - See Part Catalog  
 Description: 6-Way F 0.64 Generation Y Series( BK)

**Terminal Part Information**

Terminal Type ID	Terminated Lead	Diagnostic Test Probe	Terminal Removal Tool
I	Not required	J-35616-64B (L-BU)	No Tool Required

**S70E Radio Favorites Switch - Steering Wheel (D07 / NK5)**

Pin	Size	Color	Circuit	Function	Terminal Type ID	Option
1	0.35	YE / BK	6051	Steering Wheel Ground	I	—
2	0.35	WH / YE	4312	Radio Favorite Back Switch Signal	I	—
3	0.35	YE / YE	4313	Radio Favorite Forward Switch Signal	I	—
4	0.35	YE / BU	6855	Transmission Tap Down Switch Signal	I	—
5 - 6	—	—	—	Not Occupied	—	—

**S70E Radio Favorites Switch - Steering Wheel (N57 - D07)**

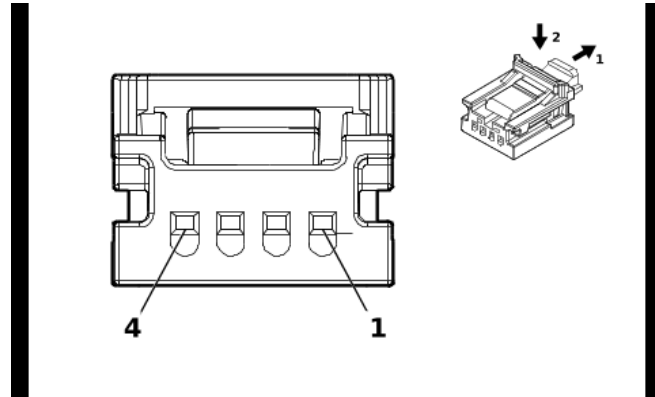

5493278

**Connector Part Information**

Harness Type: Steering Wheel Horn Switch Wiring Harness  
 OEM Connector: 13507113  
 Service Connector: Service by Harness - See Part Catalog  
 Description: 4-Way F Mini 50 Series( BK)

**Terminal Part Information**

Terminal Type ID	Terminated Lead	Diagnostic Test Probe	Terminal Removal Tool
I	Not required	EL-35616-58 (BK)	No Tool Required

**S70E Radio Favorites Switch - Steering Wheel (N57 - D07)**

Pin	Size	Color	Circuit	Function	Terminal Type ID	Option
1	0.35	BK	6051	Steering Wheel Ground	I	—
2	0.35	YE / RD	4313	Radio Favorite Forward Switch Signal	I	—
3	0.35	BU / RD	4312	Radio Favorite Back Switch Signal	I	—
4	—	—	—	Not Occupied	—	—

**S70F Radio Volume Switch - Steering Wheel (D07 / NK5)**

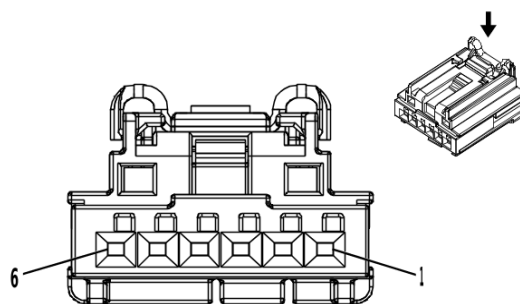

3960313

**Connector Part Information**

Harness Type: Steering Wheel Horn Switch Wiring Harness  
 OEM Connector: 13583825  
 Service Connector: Service by Harness - See Part Catalog  
 Description: 6-Way F 0.64 Generation Y Series( BK)

**Terminal Part Information**

Terminal Type ID	Terminated Lead	Diagnostic Test Probe	Terminal Removal Tool
I	Not required	J-35616-64B (L-BU)	No Tool Required

**S70F Radio Volume Switch - Steering Wheel (D07 / NK5)**

Pin	Size	Color	Circuit	Function	Terminal Type ID	Option
1	0.35	BK / WH	6051	Steering Wheel Ground	I	—
2	0.35	GY / BN	4314	Radio Volume Down Switch Signal	I	—
3	0.35	GN / BN	4315	Radio Volume Up Switch Signal	I	—
4	0.35	YE / BU	6855	Transmission Tap Down Switch Signal	I	—
5	0.35	VT / YE	5526	Tap Up/Tap Down Switch Signal	I	—
6	—	—	—	Not Occupied	—	—

**S70F Radio Volume Switch - Steering Wheel (N57 - D07)**

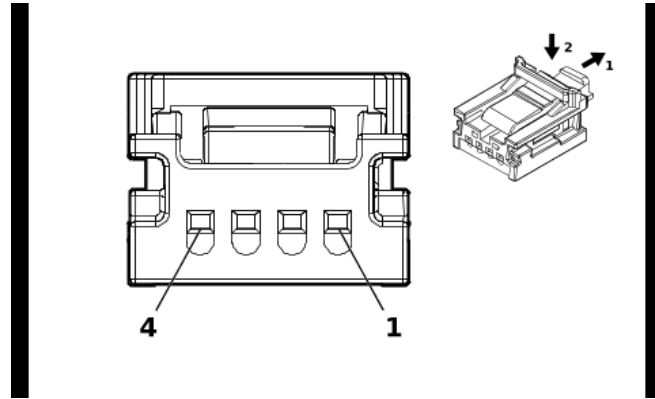

5493584

**Connector Part Information**

Harness Type: Steering Wheel Horn Switch Wiring Harness  
 OEM Connector: 13507115  
 Service Connector: Service by Harness - See Part Catalog  
 Description: 4-Way F Mini 50 Series( GY)

**Terminal Part Information**

Terminal Type ID	Terminated Lead	Diagnostic Test Probe	Terminal Removal Tool
I	Not required	J-35616-64B (L-BU)	No Tool Required

**S70F Radio Volume Switch - Steering Wheel (N57 - D07)**

Pin	Size	Color	Circuit	Function	Terminal Type ID	Option
1	0.35	BK	6051	Steering Wheel Ground	I	—
2	0.35	GN / RD	4314	Radio Volume Down Switch Signal	I	—
3	0.35	OG / RD	4315	Radio Volume Up Switch Signal	I	—
4	—	—	—	Not Occupied	—	—

**S70L Cruise Control Switch (D07 / NK5)**

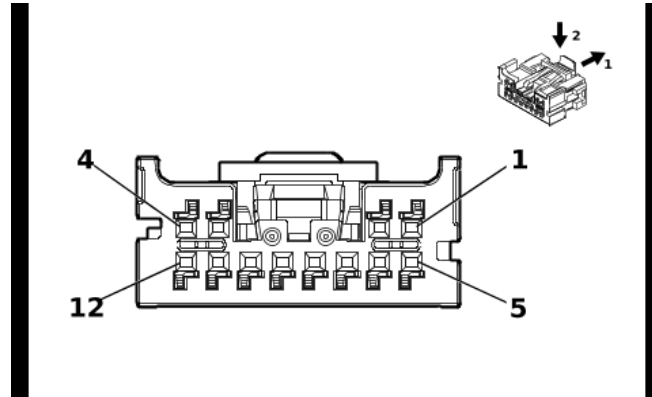

5823893

**Connector Part Information**

Harness Type: Steering Wheel Horn Switch Wiring Harness  
 OEM Connector: 13541203  
 Service Connector: Service by Harness - See Part Catalog  
 Description: 12-Way F Mini 50 Series( GY)

**Terminal Part Information**

Terminal Type ID	Terminated Lead	Diagnostic Test Probe	Terminal Removal Tool
I	Not required	EL-35616-58 (BK)	No Tool Required

**S70L Cruise Control Switch (D07 / NK5)**

Pin	Size	Color	Circuit	Function	Terminal Type ID	Option
1	0.35	RD / GN	5140	Battery Positive Voltage	I	—
2	0.35	YE / BK	3893	Steering Wheel LED Backlight Dimming Control	I	N57+ D07
	0.35	PK	3893	Steering Wheel LED Backlight Dimming Control	I	NK5
3	0.35	BN / GN	1884	Cruise Control Set/Coast/Resume/Accelerate Switch Signal	I	—
4	0.35	GY / GN	5737	Distance Sensing Cruise Control Gap Up/Down Switch Signal	I	—
5	—	—	—	Not Occupied	—	—
6	0.35	BK / WH	6051	Steering Wheel Ground	I	—
7	0.35	BN / WH	5884	Steering Wheel Heating Switch LED Control	I	K13
8	0.35	YE / GY	5883	Steering Wheel Heating Switch Signal	I	K13
9	0.35	VT	3892	Indicator Dimming Control 2	I	—
10	0.35	BK / VT	1449	Steering Wheel Resistor Ladder Low Reference	I	K13
11 - 12	—	—	—	Not Occupied	—	—



**S70L Cruise Control Switch (N57 - D07)**

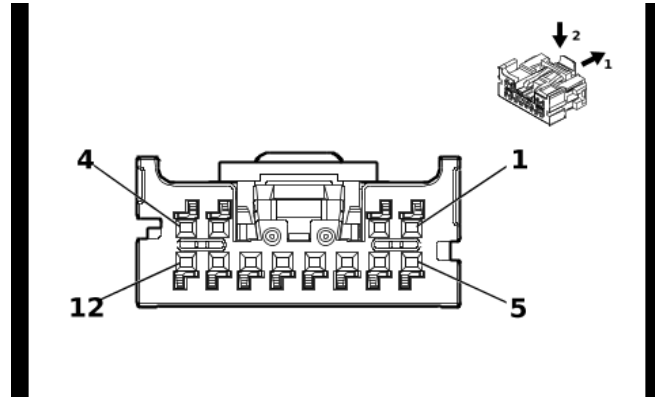

5823893

**Connector Part Information**

Harness Type: Steering Wheel Horn Switch Wiring Harness  
 OEM Connector: 13541203  
 Service Connector: Service by Harness - See Part Catalog  
 Description: 12-Way F Mini 50 Series( GY)

**Terminal Part Information**

Terminal Type ID	Terminated Lead	Diagnostic Test Probe	Terminal Removal Tool
I	Not required	EL-35616-58 (BK)	No Tool Required

**S70L Cruise Control Switch (N57 - D07)**

Pin	Size	Color	Circuit	Function	Terminal Type ID	Option
1	0.35	GN / GN	5140	Battery Positive Voltage	I	—
2	0.35	YE / BK	3893	Steering Wheel LED Backlight Dimming Control	I	—
3	0.35	GN / OG	1884	Cruise Control Set/Coast/Resume/Accelerate Switch Signal	I	—
4	0.35	GY / GN	5737	Distance Sensing Cruise Control Gap Up/Down Switch Signal	I	—
5	—	—	—	Not Occupied	—	—
6	0.35	BK	6051	Steering Wheel Ground	I	—
7	0.35	GY / OG	5884	Steering Wheel Heating Switch LED Control	I	K13
8	0.35	YE / GY	5883	Steering Wheel Heating Switch Signal	I	K13
9	0.35	BK / RD	3892	Indicator Dimming Control 2	I	—
10	0.35	BK / VT	1449	Steering Wheel Resistor Ladder Low Reference	I	—
11 - 12	—	—	—	Not Occupied	—	—

**S70R Radio Control Switch - Steering Wheel (D07 / NK5)**

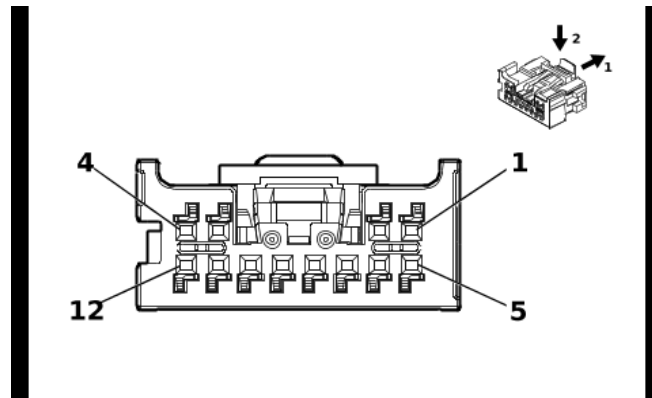

5911307

**Connector Part Information**

Harness Type: Steering Wheel Horn Switch Wiring Harness  
 OEM Connector: 13541204  
 Service Connector: Service by Harness - See Part Catalog  
 Description: 12-Way F Mini 50 Series( GY)

**Terminal Part Information**

Terminal Type ID	Terminated Lead	Diagnostic Test Probe	Terminal Removal Tool
I	Not required	EL-35616-58 (BK)	No Tool Required

**S70R Radio Control Switch - Steering Wheel (D07 / NK5)**

Pin	Size	Color	Circuit	Function	Terminal Type ID	Option
1	0.35	GN / GN	5140	Battery Positive Voltage	I	—
2	0.35	YE / BK	3893	Steering Wheel LED Backlight Dimming Control	I	N57+ D07
3	0.35	GN / BK	3894	Instrument Panel Cluster Control Module LIN Bus 1	I	—
4 - 5	—	—	—	Not Occupied	—	—
6	0.35	BK / WH	6051	Steering Wheel Ground	I	—
7	0.35	WH / YE	4313	Radio Favorite Forward Switch Signal	I	—
8	0.35	YE / BU	4312	Radio Favorite Back Switch Signal	I	—
9	0.35	VT	3892	Indicator Dimming Control 2	I	—
10	0.35	BU	4315	Radio Volume Up Switch Signal	I	—
11	0.35	GN / BN	4314	Radio Volume Down Switch Signal	I	—
12	—	—	—	Not Occupied	—	—

**S70R Radio Control Switch - Steering Wheel (N57 - D07)**

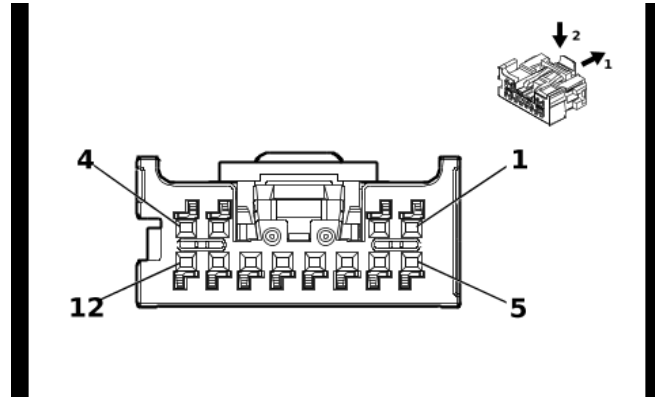

5911307

**Connector Part Information**

Harness Type: Steering Wheel Horn Switch Wiring Harness  
 OEM Connector: 13541204  
 Service Connector: Service by Harness - See Part Catalog  
 Description: 12-Way F Mini 50 Series( GY)

**Terminal Part Information**

Terminal Type ID	Terminated Lead	Diagnostic Test Probe	Terminal Removal Tool
I	Not required	EL-35616-58 (BK)	No Tool Required

**S70R Radio Control Switch - Steering Wheel (N57 - D07)**

Pin	Size	Color	Circuit	Function	Terminal Type ID	Option
1	0.35	GN	5140	Battery Positive Voltage	I	—
2	0.35	PK	3893	Steering Wheel LED Backlight Dimming Control	I	—
3	0.35	GN / BK	3894	Instrument Panel Cluster Control Module LIN Bus 1	I	—
4 - 5	—	—	—	Not Occupied	—	—
6	0.35	BK / WH	6051	Steering Wheel Ground	I	—
7	0.35	WH / YE	4313	Radio Favorite Forward Switch Signal	I	—
8	0.35	YE / RD	4312	Radio Favorite Back Switch Signal	I	—
9	0.35	BK / RD	3892	Indicator Dimming Control 2	I	—
10	0.35	OG / RD	4315	Radio Volume Up Switch Signal	I	—
11	0.35	GN / BN	4314	Radio Volume Down Switch Signal	I	—
12	—	—	—	Not Occupied	—	—

**S71 Steering Column Tilt Wheel and Telescope Switch (N38)**

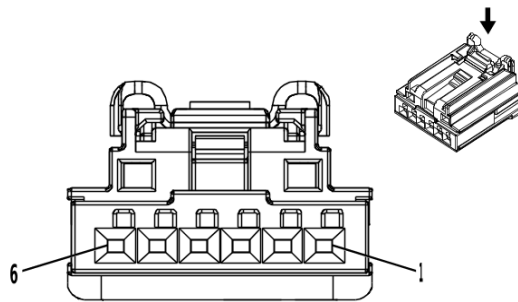

4145138

**Connector Part Information**

Harness Type: Instrument Panel Wiring Harness  
 OEM Connector: 2035363-2  
 Service Connector: 19356359  
 Description: 6-Way F 0.64 Generation Y Series( BK)

**Terminal Part Information**

Terminal Type ID	Terminated Lead	Diagnostic Test Probe	Terminal Removal Tool
I	Not required	J-35616-64B (L-BU)	No Tool Required

**S71 Steering Column Tilt Wheel and Telescope Switch (N38)**

Pin	Size	Color	Circuit	Function	Terminal Type ID	Option
1	0.5	BU / YE	2094	Steering Column Tilt and Telescope Switch Forward Signal	I	—
2	0.5	YE / BN	2097	Steering Column Tilt and Telescope Switch Down Signal	I	—
3	0.5	BN / GY	2096	Steering Column Tilt and Telescope Switch Up Signal	I	—
4	—	—	—	Not Occupied	—	—
5	0.5	GN / BN	2095	Steering Column Tilt and Telescope Switch Rearward Signal	I	—
6	0.5	VT / BK	2020	Steering Column Tilt and Telescope Switch Feedback Signal	I	—

## S76 Trailer Brake Control Switch (- D07)

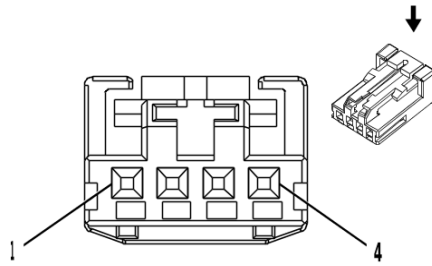

2717162

### Connector Part Information

Harness Type: Instrument Panel Wiring Harness  
 OEM Connector: 1-936119-1  
 Service Connector: 19367524  
 Description: 4-Way F 0.64 Micro-Quadlock Series( BK)

### Terminal Part Information

Terminal Type ID	Terminated Lead	Diagnostic Test Probe	Terminal Removal Tool
I	Not required	J-35616-64B (L-BU)	No Tool Required

### S76 Trailer Brake Control Switch (- D07)

Pin	Size	Color	Circuit	Function	Terminal Type ID	Option
1	0.5	RD / YE	2340	Battery Positive Voltage	I	—
2	0.35	GN / BU	2733	Brake System Control Module LIN Bus 2	I	—
3	0.5	BK	1050	Ground	I	—
4	—	—	—	Not Occupied	—	—

**S76 Trailer Brake Control Switch (D07)**

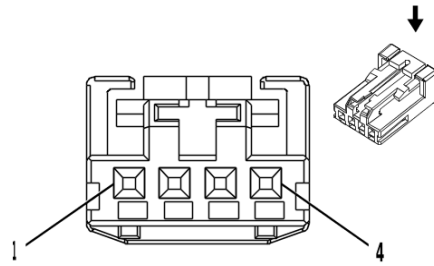

2717162

**Connector Part Information**

Harness Type: Front Floor Console Wiring Harness  
 OEM Connector: 1-936119-1  
 Service Connector: Service by Harness - See Part Catalog  
 Description: 4-Way F 0.64 Micro-Quadlock Series( BK)

**Terminal Part Information**

Terminal Type ID	Terminated Lead	Diagnostic Test Probe	Terminal Removal Tool
I	Not required	J-35616-64B (L-BU)	No Tool Required

**S76 Trailer Brake Control Switch (D07)**

Pin	Size	Color	Circuit	Function	Terminal Type ID	Option
1	0.5	RD / YE	2340	Battery Positive Voltage	I	—
2	0.35	GN / BU	2733	Brake System Control Module LIN Bus 2	I	—
3	0.5	BK	1350	Ground	I	—
4	—	—	—	Not Occupied	—	—

### S78 Turn Signal Switch

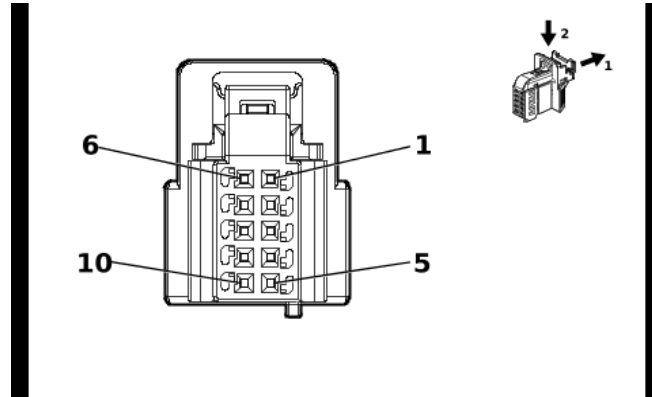

5838155

#### Connector Part Information

Harness Type: Instrument Panel Wiring Harness  
 OEM Connector: 2310000-1  
 Service Connector: 13518417  
 Description: 10-Way F 0.64 MQS Series( BK)

#### Terminal Part Information

Terminal Type ID	Terminated Lead	Diagnostic Test Probe	Terminal Removal Tool
I	19300632	J-35616-64B (L-BU)	J-38125-215A

#### S78 Turn Signal Switch

Pin	Size	Color	Circuit	Function	Terminal Type ID	Option
1	0.35	WH / GN	2915	Left Turn Signal Switch Signal	I	—
2	0.35	VT / BU	2916	Right Turn Signal Switch Signal	I	—
3	0.5	BK / WH	851	Signal Ground	I	—
4	0.35	GY / BN	3904	Auto High Beam Assist Switch Signal	I	—
5	0.35	WH / BK	94	Windshield Washer Switch Signal	I	—
6	0.35	YE / BN	307	Headlamp Switch Flash Signal	I	—
7	0.35	WH	524	High Beam Select Switch High Beam Signal	I	—
8	0.35	BK / GY	6009	Windshield Wiper Switch Low Reference	I	—
9	0.5	GY	1715	Windshield Wiper Switch High Signal	I	—
10	0.35	YE / BU	1714	Windshield Wiper Switch Low Signal	I	—

**S79D Front Side Door Window Control Switch - Driver X1**

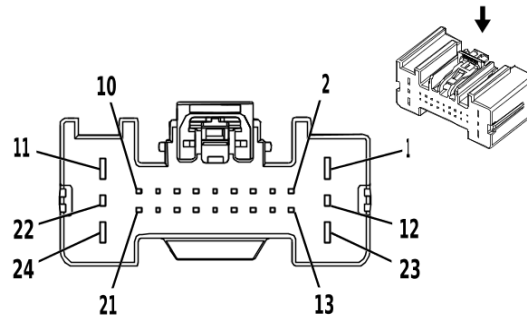

2871905

**Connector Part Information**

Harness Type: Front Side Door Door Lock Door Wiring Harness - Driver  
 OEM Connector: 7287-3260-30  
 Service Connector: Service by Harness - See Part Catalog  
 Description: 24-Way F 0.64 GEN-Y, 1.5, 2.8 YESC Series( BK)

**Terminal Part Information**

Terminal Type ID	Terminated Lead	Diagnostic Test Probe	Terminal Removal Tool
I	Not required	J-35616-14 (GN)	No Tool Required
II	Not required	J-35616-2A (GY)	No Tool Required
III	Not required	J-35616-4A (PU)	No Tool Required
IV	Not required	J-35616-64B (L-BU)	No Tool Required

**S79D Front Side Door Window Control Switch - Driver X1**

Pin	Size	Color	Circuit	Function	Terminal Type ID	Option
1	0.5	WH / BN	2764	Window Switch Left Front Down Signal	III	—
2	0.5	GN	2766	Power Window Switch Left Front Express Signal	IV	—
3	0.5	BN / YE	2771	Left Front Door Lock Switch Lock Signal	IV	—
4	0.5	BN / WH	2772	Left Front Door Lock Switch Unlock Signal	IV	—
5	0.5	GY / VT	2767	LED Ambient Lighting Control Left Front Door	IV	—
6	—	—	—	Not Occupied	—	—
7	0.5	BN / GY	4784	Left Front Door LED Backlight Dimming Control	IV	—
8	0.35	GY / YE	1760	Left Side Object Detection LED Control	IV	—
9	0.5	WH / GN	2786	Left Front Mirror Motor Fold In Control	IV	—
10	0.5	YE / BN	2789	Left Front Mirror Motor Common Control	IV	—
11	0.5	BK	1550	Ground	III	—
12	0.5	GY / WH	2785	Left Front Mirror Motor Fold Out Control	I	—
13 - 16	—	—	—	Not Occupied	—	—
17	0.5	WH / VT	4258	Left Front Door Lock Status Signal	IV	—
18	0.5	VT / BU	2788	Left Front Mirror Motor Up [+] Down [-] Control	IV	—
19	0.5	BN / BK	2790	Left Front Mirror Motor Right [+] Left [-] Control	IV	—
20	—	—	—	Not Occupied	—	—
21	0.5	GN / YE	6134	Body Control Module LIN Bus 3	IV	—
22	0.5	WH	606	Left Outside Rearview Mirror Heater Control	II	—



**S79D Front Side Door Window Control Switch - Driver X1 (cont'd)**

<b>Pin</b>	<b>Size</b>	<b>Color</b>	<b>Circuit</b>	<b>Function</b>	<b>Terminal Type ID</b>	<b>Option</b>
23	0.5	GY / GN	2763	Window Switch Left Front Up Signal	III	—
24	0.5	RD / BU	1240	Battery Positive Voltage	III	—

**S79D Front Side Door Window Control Switch - Driver X2 (A45)**

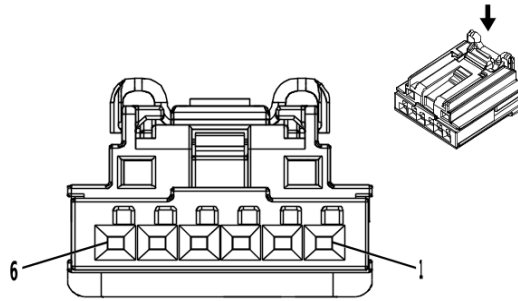

4145138

**Connector Part Information**

Harness Type: Front Side Door Door Lock Door Wiring Harness - Driver  
 OEM Connector: 2035363-2  
 Service Connector: Service by Harness - See Part Catalog  
 Description: 6-Way F 0.64 Generation Y Series( BK)

**Terminal Part Information**

Terminal Type ID	Terminated Lead	Diagnostic Test Probe	Terminal Removal Tool
I	Not required	J-35616-64B (L-BU)	No Tool Required

**S79D Front Side Door Window Control Switch - Driver X2 (A45)**

Pin	Size	Color	Circuit	Function	Terminal Type ID	Option
1	0.5	WH / YE	2792	Left Front Mirror Position Sensor Left [-] Right [+] Signal	I	—
2	0.5	GY / BN	2787	Left Front Mirror Position Sensor Up [+] Down [-] Signal	I	—
3	0.5	VT / RD	2791	Left Front Mirror Position Sensor High Refer- ence	I	—
4	0.5	BK / BN	673	Left Outside Rearview Mirror Position Sensor Low Reference	I	—
5 - 6	—	—	—	Not Occupied	—	—

**S79LR Rear Side Door Window Switch - Left**

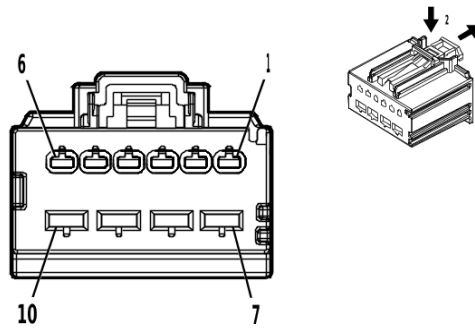

5035058

**Connector Part Information**

Harness Type: Rear Side Door Door Wiring Harness - Left Rear  
 OEM Connector: 31372-1600  
 Service Connector: Service by Harness - See Part Catalog  
 Description: 10-Way F 1.5, 2.8 MX Series( BK)

**Terminal Part Information**

Terminal Type ID	Terminated Lead	Diagnostic Test Probe	Terminal Removal Tool
I	Not required	J-35616-2A (GY)	No Tool Required
II	Not required	J-35616-4A (PU)	No Tool Required

**S79LR Rear Side Door Window Switch - Left**

Pin	Size	Color	Circuit	Function	Terminal Type ID	Option
1	0.5	GN / GY	6135	Body Control Module LIN Bus 4	I	—
2	0.5	GY	747	Left Rear Door Ajar Switch Signal	I	—
3	0.5	BK	1550	Ground	I	—
4 - 6	—	—	—	Not Occupied	—	—
7	2.5	BK	1550	Ground	II	—
8	2.5	RD / BU	3240	Battery Positive Voltage	II	—
9	2	BU / VT	668	Left Rear Window Motor Up Control	II	—
10	2	YE / BU	669	Left Rear Window Motor Down Control	II	—

**S79P Front Side Door Window Switch - Passenger**

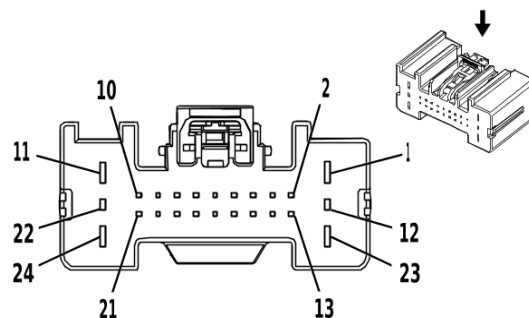

2871905

**Connector Part Information**

Harness Type: Front Side Door Door Lock Door Wiring Harness - Passenger  
 OEM Connector: 7287-3260-30  
 Service Connector: Service by Harness - See Part Catalog  
 Description: 24-Way F 0.64 GEN-Y, 1.5, 2.8 YESC Series( BK)

**Terminal Part Information**

Terminal Type ID	Terminated Lead	Diagnostic Test Probe	Terminal Removal Tool
I	Not required	J-35616-2A (GY)	No Tool Required
II	Not required	J-35616-4A (PU)	No Tool Required
III	Not required	J-35616-64B (L-BU)	No Tool Required

**S79P Front Side Door Window Switch - Passenger**

Pin	Size	Color	Circuit	Function	Terminal Type ID	Option
1	2.5	BK	1350	Ground	II	—
2	0.5	YE / RD	2799	Right Front Mirror Position Sensor High Reference	III	—
3	0.5	GN / BK	2798	Right Front Mirror Motor Right [+] Left [-] Control	III	—
4	0.5	YE / VT	2796	Right Front Mirror Motor Up [+] Down [-] Control	III	—
5	0.5	WH / BN	2768	LED Ambient Lighting Control Right Front Door	III	—
6	—	—	—	Not Occupied	—	—
7	0.5	GY / VT	4638	LED Backlight Dimming Control Right Front Door	III	—
8	0.35	GY	1761	Right Side Object Detection LED Control	III	—
9	0.5	BU / GY	2794	Right Front Mirror Motor Fold In Control	III	—
10	0.5	YE / WH	2793	Right Front Mirror Motor Fold Out Control	III	—
11	2.5 0.5	GN / GY GN	666 1184	Right Front Window Motor Up Control Window Switch Right Front Up Signal	II II	AED AEF
12	0.5	BN / VT	607	Right Outside Rearview Mirror Heater Control	I	—
13	—	—	—	Not Occupied	—	—
14	0.5	GN / YE	6134	Body Control Module LIN Bus 3	III	—
15	0.5	VT / WH	2800	Right Front Mirror Position Sensor Left [-] Right [+] Signal	III	—
16	0.5	BU / YE	2795	Right Front Mirror Position Sensor Up [+] Down [-] Signal	III	—

**S79P Front Side Door Window Switch - Passenger (cont'd)**

<b>Pin</b>	<b>Size</b>	<b>Color</b>	<b>Circuit</b>	<b>Function</b>	<b>Terminal Type ID</b>	<b>Option</b>
17	0.5	YE / VT	2773	Right Front Door Lock Switch Lock Control	III	—
18	0.5	BN / VT	2774	Right Front Door Lock Switch Unlock Control	III	—
19	—	—	—	Not Occupied	—	—
20	0.5	GY	746	Right Front Door Ajar Switch Signal	III	AED
	0.5	VT / GY	2765	Window Switch Right Front Express Signal	III	AEF
21	0.5	WH	2797	Right Front Mirror Motor Common Control	III	—
22	0.5	BK / GN	675	Right Outside Rearview Mirror Position Sensor Low Reference	I	—
23	2.5	RD / BN	4240	Battery Positive Voltage	II	—
24	2.5	YE / BU	667	Right Front Window Motor Down Control	II	AED
	0.5	BN	5295	Window Switch Right Front Down Signal	II	AEF

**S79RR Rear Side Door Window Switch - Right**

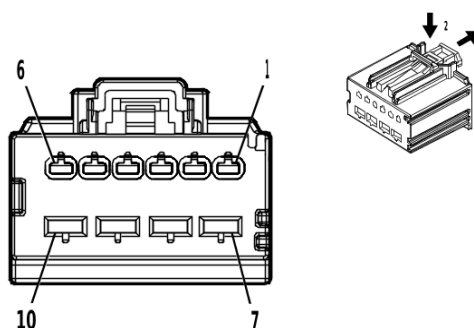

5035058

**Connector Part Information**

Harness Type: Rear Side Door Door Wiring Harness - Right Rear  
 OEM Connector: 31372-1600  
 Service Connector: Service by Harness - See Part Catalog  
 Description: 10-Way F 1.5, 2.8 MX Series( BK)

**Terminal Part Information**

Terminal Type ID	Terminated Lead	Diagnostic Test Probe	Terminal Removal Tool
I	Not required	J-35616-2A (GY)	No Tool Required
II	Not required	J-35616-4A (PU)	No Tool Required

**S79RR Rear Side Door Window Switch - Right**

Pin	Size	Color	Circuit	Function	Terminal Type ID	Option
1	0.5	GN / GY	6135	Body Control Module LIN Bus 4	I	—
2	0.5	GY	748	Right Rear Door Ajar Switch Signal	I	—
3 - 6	—	—	—	Not Occupied	—	—
7	2.5	BK	1350	Ground	II	—
8	2.5	YE / BK	4840	Battery Positive Voltage	II	—
9	2	BU / GY	670	Right Rear Window Motor Up Control	II	—
10	2	GN / BK	671	Right Rear Window Motor Down Control	II	—

## S86 Vehicle Stability Control System Switch

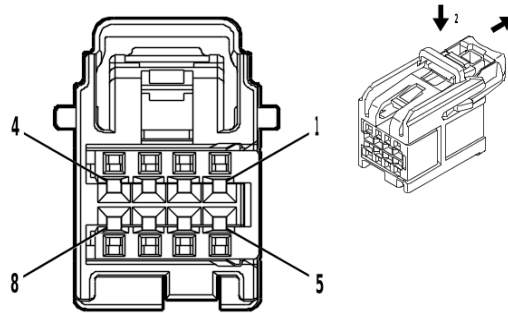

4935776

### Connector Part Information

Harness Type: Instrument Panel Wiring Harness  
 OEM Connector: 15526972  
 Service Connector: 19370429  
 Description: 8-Way F 0.64 OCS Series( BK)

### Terminal Part Information

Terminal Type ID	Terminated Lead	Diagnostic Test Probe	Terminal Removal Tool
I	Not required	J-35616-64B (L-BU)	No Tool Required

### S86 Vehicle Stability Control System Switch

Pin	Size	Color	Circuit	Function	Terminal Type ID	Option
1	0.35	BU / VT	1788	Traction Control Switch Signal 1	I	—
2	0.35	YE	6817	LED Backlight Dimming Control 1	I	—
3	0.35	BN	7291	Major Endgate Release Switch Signal Interior	I	—
4	0.35	BU / YE	6844	ABS/Traction Control Hill Descent Control Switch Signal	I	—
5	—	—	—	Not Occupied	—	—
6	0.35	BK / WH	851	Signal Ground	I	—
7	0.35	GN / WH	111	Hazard Warning Switch Signal	I	—
8	0.35	GY	1198	Endgate Release Switch Analog Signal Interior	I	—

### S91 Parking Brake Control Switch

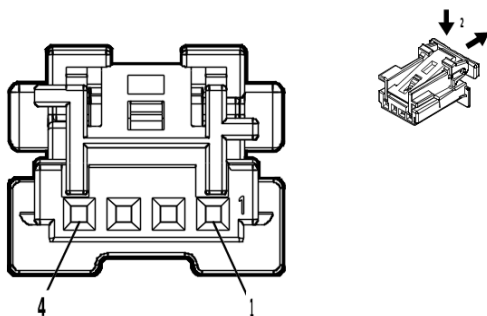

4997407

#### Connector Part Information

Harness Type: Instrument Panel Wiring Harness  
 OEM Connector: 2294218-1  
 Service Connector: 19371192  
 Description: 4-Way F 0.64 Micro-Quadlock Series( BK)

#### Terminal Part Information

Terminal Type ID	Terminated Lead	Diagnostic Test Probe	Terminal Removal Tool
I	Not required	J-35616-64B (L-BU)	No Tool Required

#### S91 Parking Brake Control Switch

Pin	Size	Color	Circuit	Function	Terminal Type ID	Option
1	0.35	RD / YE	4340	Battery Positive Voltage	I	—
2	0.5	GN / YE	2731	Brake System Control Module LIN Bus 1	I	—
3	—	—	—	Not Occupied	—	—
4	0.35	BK / WH	851	Signal Ground	I	—



**S126 Ride Control Switch**

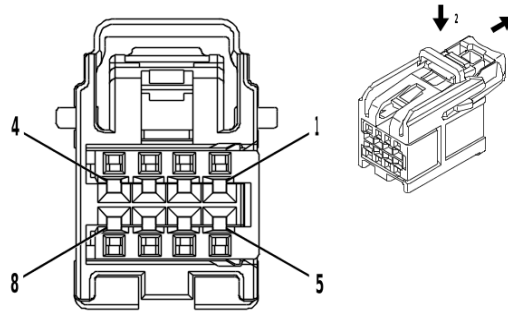

4232228

**Connector Part Information**

Harness Type: Instrument Panel Wiring Harness  
 OEM Connector: 15526973  
 Service Connector: 19353873  
 Description: 8-Way F 0.64 OCS Series( GY)

**Terminal Part Information**

Terminal Type ID	Terminated Lead	Diagnostic Test Probe	Terminal Removal Tool
I	Not required	J-35616-64B (L-BU)	No Tool Required

**S126 Ride Control Switch**

Pin	Size	Color	Circuit	Function	Terminal Type ID	Option
1	0.35	WH / BN	2203	Enhanced Driver Mode 2 Switch Signal	I	—
2	—	—	—	Not Occupied	—	—
3	0.35	BK / VT	1449	Steering Wheel Resistor Ladder Low Reference	I	—
4	0.35	YE	6817	LED Backlight Dimming Control 1	I	—
5	0.35	BK / WH	851	Signal Ground	I	—
6 - 8	—	—	—	Not Occupied	—	—

**S148L Assist Step Switch - Left (BRS)**

**Connector Part Information**

Harness Type: Assist Step Wire - Left  
 OEM Connector: ANR88725  
 Service Connector: Service by Harness - See Part Catalog  
 Description: 2-Way F

**Terminal Part Information**

Terminal Type ID	Terminated Lead	Diagnostic Test Probe	Terminal Removal Tool
I	Not required	No Tool Required	No Tool Required

**S148L Assist Step Switch - Left (BRS)**

Pin	Size	Color	Circuit	Function	Terminal Type ID	Option
1	0.5	WH	4746	Running Board Step Left Kick Switch Signal	I	—
2	0.5	BK	1151	Signal Ground	I	—

## S148R Assist Step Switch - Right (BRS)

### Connector Part Information

Harness Type: Assist Step Wire - Right  
 OEM Connector: ANR88725  
 Service Connector: Service by Harness - See Part Catalog  
 Description: 2-Way F

### Terminal Part Information

Terminal Type ID	Terminated Lead	Diagnostic Test Probe	Terminal Removal Tool
I	Not required	No Tool Required	No Tool Required

### S148R Assist Step Switch - Right (BRS)

Pin	Size	Color	Circuit	Function	Terminal Type ID	Option
1	0.5	WH	4747	Running Board Step Right Kick Switch Signal	I	—
2	0.5	BK	1151	Signal Ground	I	—

**S158 Liftgate Exterior Release Switch - Auxiliary Endgate (QT5)**

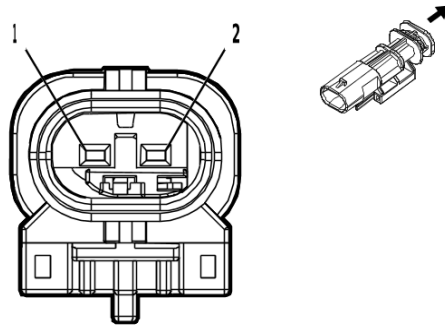

4994410

**Connector Part Information**

Harness Type: Endgate Wiring Harness  
 OEM Connector: 34899-2081  
 Service Connector: Service by Harness - See Part Catalog  
 Description: 2-Way M 1.2 MCON Series, Sealed( GY)

**Terminal Part Information**

Terminal Type ID	Terminated Lead	Diagnostic Test Probe	Terminal Removal Tool
I	Not required	J-35616-17 (L-GN)	No Tool Required

**S158 Liftgate Exterior Release Switch - Auxiliary Endgate (QT5)**

Pin	Size	Color	Circuit	Function	Terminal Type ID	Option
1	0.5	YE	7294	Minor Endgate Release Switch Discrete Signal Exterior	I	—
2	0.5	BK	1850	Ground	I	—

**S159E Liftgate Exterior Release Switch - Endgate (QT5)**

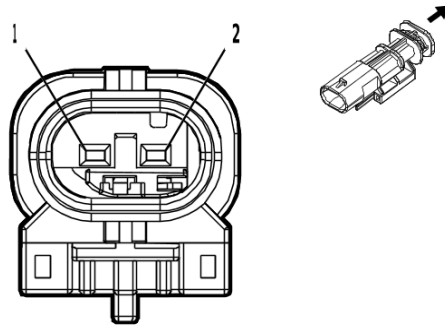

4994411

**Connector Part Information**

Harness Type: Endgate Wiring Harness  
 OEM Connector: 34899-2082  
 Service Connector: Service by Harness - See Part Catalog  
 Description: 2-Way M 1.2 MCON Series, Sealed( GY)

**Terminal Part Information**

Terminal Type ID	Terminated Lead	Diagnostic Test Probe	Terminal Removal Tool
I	Not required	J-35616-17 (L-GN)	No Tool Required

**S159E Liftgate Exterior Release Switch - Endgate (QT5)**

Pin	Size	Color	Circuit	Function	Terminal Type ID	Option
1	0.5	GY	7292	Major Endgate Release Switch Signal Exterior	I	—
2	0.5	BK	1850	Ground	I	—

**S159E Liftgate Exterior Release Switch - Endgate (QT6)**

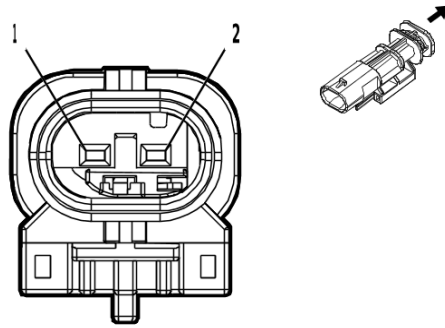

4994411

**Connector Part Information**

Harness Type: Endgate Wiring Harness  
 OEM Connector: 34899-2082  
 Service Connector: Service by Harness - See Part Catalog  
 Description: 2-Way M 1.2 MCON Series, Sealed( GY)

**Terminal Part Information**

Terminal Type ID	Terminated Lead	Diagnostic Test Probe	Terminal Removal Tool
I	Not required	J-35616-17 (L-GN)	No Tool Required

**S159E Liftgate Exterior Release Switch - Endgate (QT6)**

Pin	Size	Color	Circuit	Function	Terminal Type ID	Option
1	0.5	YE	1144	Endgate Release Switch Discrete Signal Exterior	I	—
2	0.5	BK	1850	Ground	I	—

## S171L Instrument Panel Center Accessory Function Switch - Left

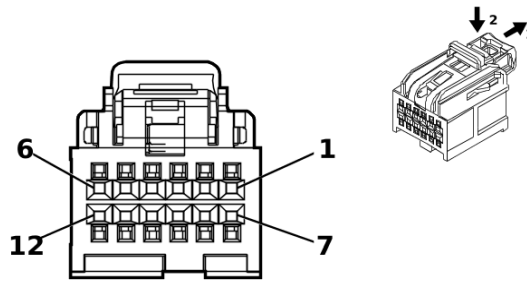

4975223

### Connector Part Information

Harness Type: Instrument Panel Wiring Harness  
 OEM Connector: 35016616  
 Service Connector: 13519750  
 Description: 12-Way F 0.64 OCS Series( BK)

### Terminal Part Information

Terminal Type ID	Terminated Lead	Diagnostic Test Probe	Terminal Removal Tool
I	19300660	J-35616-64B (L-BU)	J-38125-215A

### S171L Instrument Panel Center Accessory Function Switch - Left

Pin	Size	Color	Circuit	Function	Terminal Type ID	Option
1	0.35	GY / GN	2555	Rear Parking Assist Disable Signal	I	—
2	0.35	YE	6817	LED Backlight Dimming Control 1	I	—
3	0.35	BU / WH	3119	Roof Rail Air Bag Disable Switch Signal	I	—
4	0.35	GY / WH	3153	Lane Departure Warning Disable Switch Signal	I	—
5	0.35	WH	3152	Lane Departure Warning Indicator Control	I	—
6	0.35	BU / YE	6844	ABS/Traction Control Hill Descent Control Switch Signal	I	—
7	—	—	—	Not Occupied	—	—
8	0.35	GN / BN	5852	Rear Parking Assist Disable LED Signal	I	—
9	0.35	BK / WH	851	Signal Ground	I	—
10	0.35	BN / WH	3895	Roof Rail Air Bag Disable Switch Low Reference	I	—
11	0.35	GN	1110	Stop/Start Indicator Control	I	—
12	0.35	BU	1111	Stop/Start Switch Signal	I	—

**S171R Instrument Panel Center Accessory Function Switch - Right**

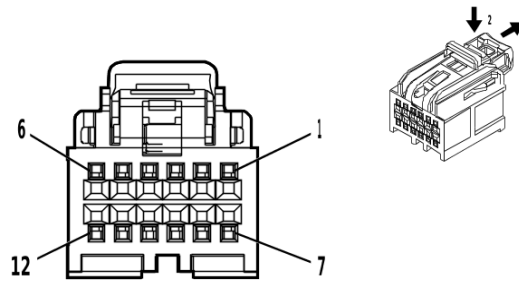

4997362

**Connector Part Information**

Harness Type: Instrument Panel Wiring Harness  
 OEM Connector: 35016613  
 Service Connector: 13519752  
 Description: 12-Way F 0.64 OCS Series( BN)

**Terminal Part Information**

Terminal Type ID	Terminated Lead	Diagnostic Test Probe	Terminal Removal Tool
I	19300660	J-35616-64B (L-BU)	J-38125-215A

**S171R Instrument Panel Center Accessory Function Switch - Right**

Pin	Size	Color	Circuit	Function	Terminal Type ID	Option
1	—	—	—	Not Occupied	—	—
2	0.35	YE	6817	LED Backlight Dimming Control 1	I	—
3	0.35	BU / YE	6844	ABS/Traction Control Hill Descent Control Switch Signal	I	—
4	0.35	YE / GN	7122	Axle Differential Lock Switch Signal	I	—
5	0.35	YE	7115	Rear Axle Differential Lock Indicator Control	I	—
6	0.35	GN	1110	Stop/Start Indicator Control	I	—
7	0.35	VT / GY	7117	Front Axle Differential Lock Indicator Control	I	—
8	0.35	BU / YE	7176	All Windows Open Switch Signal	I	—
9	0.35	BK / WH	851	Signal Ground	I	—
10	0.35	WH	6816	Indicator Dimming Control	I	—
11	—	—	—	Not Occupied	—	—
12	0.35	BU	1111	Stop/Start Switch Signal	I	URC
	0.35	BU / GY	4990	Driver Mode 1 Switch Signal	I	- URC



## S172 Auxiliary Multifunction Switch

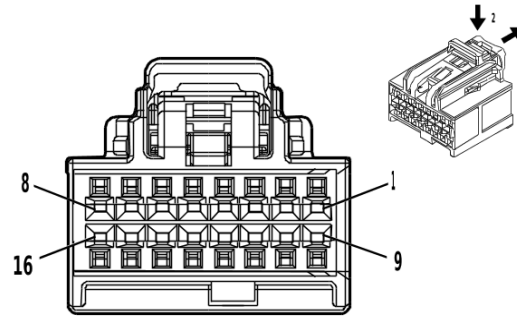

4873243

### Connector Part Information

Harness Type: Auxiliary Fuse Block Wiring Harness  
 OEM Connector: 35016343  
 Service Connector: Service by Harness - See Part Catalog  
 Description: 16-Way F 0.64 OCS Series( BK)

### Terminal Part Information

Terminal Type ID	Terminated Lead	Diagnostic Test Probe	Terminal Removal Tool
I	Not required	J-35616-64B (L-BU)	No Tool Required

### S172 Auxiliary Multifunction Switch

Pin	Size	Color	Circuit	Function	Terminal Type ID	Option
1	—	—	—	Not Occupied	—	—
2	0.35	YE	6817	LED Backlight Dimming Control 1	I	—
3	0.35	WH	6816	Indicator Dimming Control	I	—
4 - 5	—	—	—	Not Occupied	—	—
6	0.35	BU / WH	10716	Upfitter Accessory Relay 1 Coil Control	I	—
7	0.35	VT / GY	10717	Upfitter Accessory Relay 2 Coil Control	I	—
8	0.35	GN / BN	10718	Upfitter Accessory Relay 3 Coil Control	I	—
9	0.35	WH / YE	10719	Upfitter Accessory Relay 4 Coil Control	I	—
10	0.35	GY / VT	10720	Upfitter Accessory Relay 5 Coil Control	I	—
11	—	—	—	Not Occupied	—	—
12	0.75	BK / WH	851	Signal Ground	I	—
13 - 16	—	—	—	Not Occupied	—	—

**S192 Radio Function Switch (IOR)**

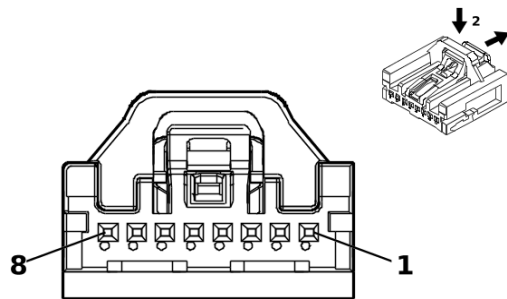

5200269

**Connector Part Information**

Harness Type: Instrument Panel Wiring Harness  
 OEM Connector: 35068228  
 Service Connector: 84769201  
 Description: 8-Way F Mini 50 Series( BK)

**Terminal Part Information**

Terminal Type ID	Terminated Lead	Diagnostic Test Probe	Terminal Removal Tool
I	Not required	EL-35616-58 (BK)	No Tool Required

**S192 Radio Function Switch (IOR)**

Pin	Size	Color	Circuit	Function	Terminal Type ID	Option
1	0.35	YE / RD	11236	Radio Switch 5 Volt Reference	I	—
2	0.35	BK / BU	11237	Radio Switch Low Reference 1	I	—
3	0.35	BN / WH	11233	Radio Switch Power ON/OFF Switch Signal	I	—
4	0.35	BK / GN	11238	Radio Switch Low Reference 2	I	—
5	0.35	BU / GY	11244	Radio Switch Dimming Control	I	—
6	0.35	VT / WH	11245	Radio Switch Buttons Signal	I	—
7	0.35	BU	11235	Radio Switch Volume Up Signal	I	—
8	0.35	GY / BN	11234	Radio Switch Volume Down Signal	I	—

**T1 DC/AC Converter Control Module X1 (KI4 / KI5)**

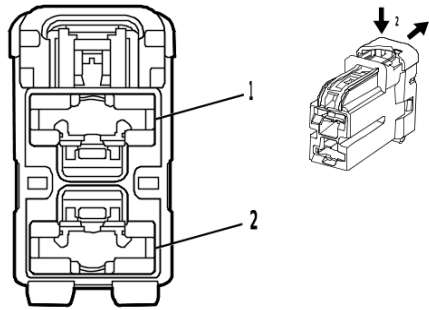

2453116

**Connector Part Information**

Harness Type: Body Wiring Harness  
 OEM Connector: 7283-0724-30  
 Service Connector: 85011842  
 Description: 2-Way F 9.5 Series( BK)

**Terminal Part Information**

Terminal Type ID	Terminated Lead	Diagnostic Test Probe	Terminal Removal Tool
I	Not required	J-35616-22 (RD)	No Tool Required

**T1 DC/AC Converter Control Module X1 (KI4 / KI5)**

Pin	Size	Color	Circuit	Function	Terminal Type ID	Option
1	5	BN / BK	4629	DC/AC Inverter Control	I	—
2	5	BK	1550	Ground	I	—

**T1 DC/AC Converter Control Module X2**

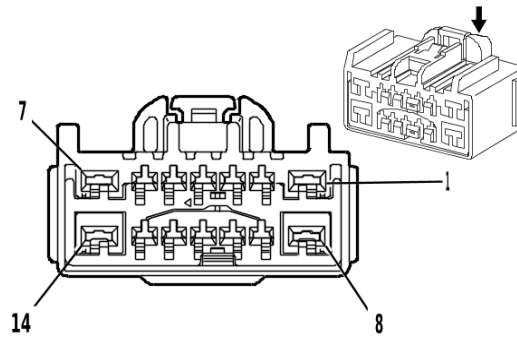

1540775

**Connector Part Information**

Harness Type: Body Rear Wiring Harness Extension Harness  
 OEM Connector: 7289-7631-90  
 Service Connector: Service by Harness - See Part Catalog  
 Description: 14-Way F 1.5, 2.8 YESC Series( BU)

**Terminal Part Information**

Terminal Type ID	Terminated Lead	Diagnostic Test Probe	Terminal Removal Tool
I	Not required	J-35616-2A (GY)	No Tool Required
II	Not required	J-35616-4A (PU)	No Tool Required

**T1 DC/AC Converter Control Module X2**

Pin	Size	Color	Circuit	Function	Terminal Type ID	Option
1	0.75	BK	10117	AC Outlet Phase A Control	II	—
2	0.5	VT / RD	4049	AC Power Outlet Sensor High Reference	I	—
3	0.35	VT / WH	239	Run/Crank Ignition 1 Voltage	I	—
4	0.5	WH / GN	4628	DC/AC Inverter Relay Control	I	—
5	0.5	BU / BN	6807	DC/AC Inverter Control	I	—
6	—	—	—	Not Occupied	—	—
7	0.75	BK / WH	10120	AC Outlet 2 Phase A Control	II	—
8	0.75	RD	10118	AC Outlet Phase B Control	II	—
9	0.35	Bare	10116	AC Outlet Low Reference	I	—
10	0.5	GN / BU	6133	Body Control Module LIN Bus 2	I	—
11	—	—	—	Not Occupied	—	—
12	0.5	GN / BN	2266	DC/AC Inverter Control 2	I	—
13	0.35	Bare	10119	AC Outlet 2 Low Reference	I	—
14	0.75	RD / WH	10121	AC Outlet 2 Phase B Control	II	—

### T3 Audio Amplifier X1 (UQA / UQS)

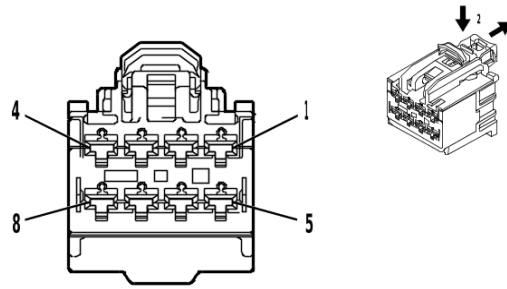

4875738

#### Connector Part Information

Harness Type: Body Wiring Harness  
 OEM Connector: 33223792  
 Service Connector: 19369366  
 Description: 8-Way F 2.8 OCS Series( BK)

#### Terminal Part Information

Terminal Type ID	Terminated Lead	Diagnostic Test Probe	Terminal Removal Tool
I	Not required	J-35616-4A (PU)	No Tool Required

#### T3 Audio Amplifier X1 (UQA / UQS)

Pin	Size	Color	Circuit	Function	Terminal Type ID	Option
1	2.5	BU / GY	346	Left/Rear Subwoofer [+] Control	I	—
2	0.75	YE	200	Right Front Speaker 1 [+] Control	I	—
3	0.75	BU	201	Left Front Speaker 1 [+] Control	I	—
4	2.5	RD / YE	3740	Battery Positive Voltage	I	—
5	2.5	GN / BK	1794	Left/Rear Subwoofer [-] Control	I	—
6	0.75	YE / BK	117	Right Front Speaker [-] Control 1	I	—
7	0.75	BN / BU	118	Left Front Speaker [-] Control 1	I	—
8	2.5	BK / WH	1051	Signal Ground	I	—

**T3 Audio Amplifier X2 (UQA / UQS)**

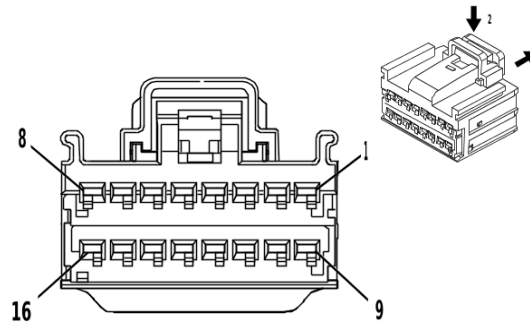

4332214

**Connector Part Information**

Harness Type: Body Wiring Harness  
 OEM Connector: 15512506  
 Service Connector: 13591061  
 Description: 16-Way F 1.5 OCS Series( BK)

**Terminal Part Information**

Terminal Type ID	Terminated Lead	Diagnostic Test Probe	Terminal Removal Tool
I	84757974	J-35616-2A (GY)	J-38125-215A

**T3 Audio Amplifier X2 (UQA / UQS)**

Pin	Size	Color	Circuit	Function	Terminal Type ID	Option
1	—	—	—	Not Occupied	—	—
2	0.75	BN / BK	1953	Right Front Midrange Speaker [-] Control	I	—
3	0.75	BU / VT	1857	Left Front Midrange Speaker [+] Control	I	—
4	1.5	WH	46	Right Rear Speaker [+] Control	I	—
5	1.5	GN	199	Left Rear Speaker [+] Control	I	—
6	—	—	—	Not Occupied	—	—
7	0.75	YE / WH	1860	Front Center Speaker [+] Control	I	—
8 - 9	—	—	—	Not Occupied	—	—
10	0.75	WH / YE	1853	Right Front Midrange Speaker [+] Control	I	—
11	0.75	BU / BN	1957	Left Front Midrange Speaker [-] Control	I	—
12	1.5	BU / BK	115	Right Rear Speaker [-] Control	I	—
13	1.5	GN / BK	116	Left Rear Speaker [-] Control	I	—
14	—	—	—	Not Occupied	—	—
15	0.75	BU / YE	1960	Front Center Speaker [-] Control	I	—
16	—	—	—	Not Occupied	—	—

### T3 Audio Amplifier X3 (UQA / UQS)

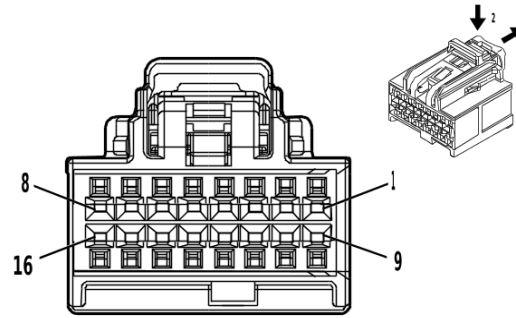

4873243

#### Connector Part Information

Harness Type: Body Wiring Harness  
 OEM Connector: 35016343  
 Service Connector: 13519738  
 Description: 16-Way F 0.64 OCS Series( BK)

#### Terminal Part Information

Terminal Type ID	Terminated Lead	Diagnostic Test Probe	Terminal Removal Tool
I	19354230	J-35616-64B (L-BU)	J-38125-215A
II	Service by Cable	No Tool Required	No Tool Required

#### T3 Audio Amplifier X3 (UQA / UQS)

Pin	Size	Color	Circuit	Function	Terminal Type ID	Option
1	0.35	YE	7215	Ethernet Bus 6 [+]	II	—
2	0.35	GN	7214	Ethernet Bus 6 [-]	II	—
3 - 4	—	—	—	Not Occupied	—	—
5	0.35	GN / WH	3005	Active Noise Cancellation Microphone 1 Signal	I	—
6 - 10	—	—	—	Not Occupied	—	—
11	0.5	BU / WH	4985	AUTOSAR CAN Bus [+] 5 Serial Data	I	—
12	0.5	BU / YE	4984	AUTOSAR CAN Bus [-] 5 Serial Data	I	—
13	0.35	GN / BK	3008	Active Noise Cancellation Microphone 1 Feed-back Signal	I	—
14 - 16	—	—	—	Not Occupied	—	—

**T4M Radio Antenna**

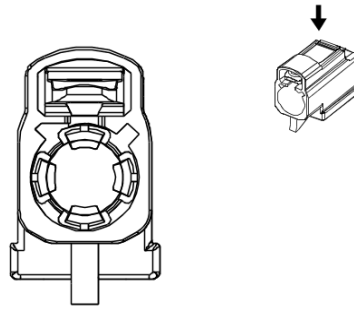

3214010

**Connector Part Information**

Harness Type: Radio Antenna Cable Extension Cable COAX  
 OEM Connector: 12784301  
 Service Connector: Service by Cable Assembly — See Part Catalog  
 Description: 1-Way F Coax Type( BK)

**Terminal Part Information**

Terminal Type ID	Terminated Lead	Diagnostic Test Probe	Terminal Removal Tool
I	Not required	No Tool Required	No Tool Required

**T4M Radio Antenna**

Pin	Size	Color	Circuit	Function	Terminal Type ID	Option
—	—	Coax Cable	—	(AM/FM) Antenna RF Signal	I	—



**T4P High Frequency Antenna X1 (- (UDA / UE1))**

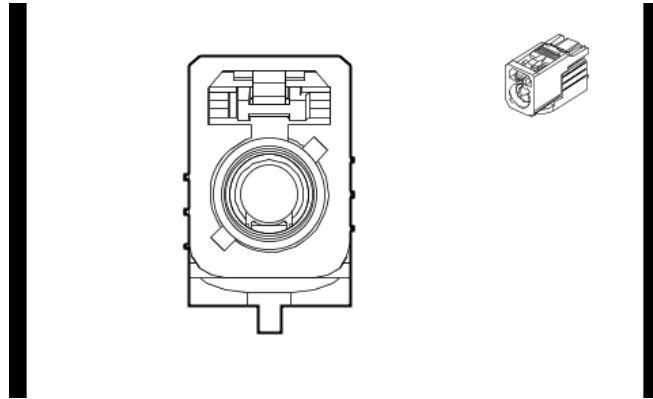

6267120

**Connector Part Information**

Harness Type: Instrument Panel Wiring Harness COAX  
 OEM Connector: 33351013  
 Service Connector: Service by Cable Assembly — See Part Catalog  
 Description: 1-Way F Coax Type( BU)

**Terminal Part Information**

Terminal Type ID	Terminated Lead	Diagnostic Test Probe	Terminal Removal Tool
I	Not required	No Tool Required	No Tool Required

**T4P High Frequency Antenna X1 (- (UDA / UE1))**

Pin	Size	Color	Circuit	Function	Terminal Type ID	Option
—	—	Coax Cable	—	(GPS only) Coaxial Antenna GPS Signal	I	—

T4P High Frequency Antenna X1 (UDA / UE1)

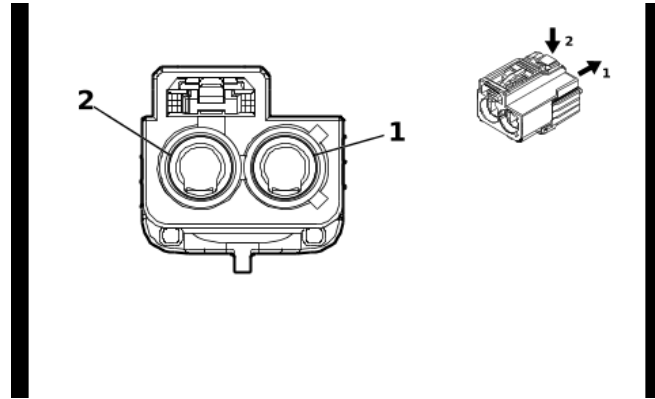

5661671

**Connector Part Information**

Harness Type: Instrument Panel Wiring Harness COAX  
 OEM Connector: 33351060  
 Service Connector: Service by Cable Assembly — See Part Catalog  
 Description: 2-Way F Coax Type( VT)

**Terminal Part Information**

Terminal Type ID	Terminated Lead	Diagnostic Test Probe	Terminal Removal Tool
I	Not required	No Tool Required	No Tool Required

**T4P High Frequency Antenna X1 (UDA / UE1)**

Pin	Size	Color	Circuit	Function	Terminal Type ID	Option
—	—	Coax Cable	—	(GPS/Cell) Coaxial Antenna Cell/GPS combined Signal	I	—

## T4P High Frequency Antenna X2 (U2K)

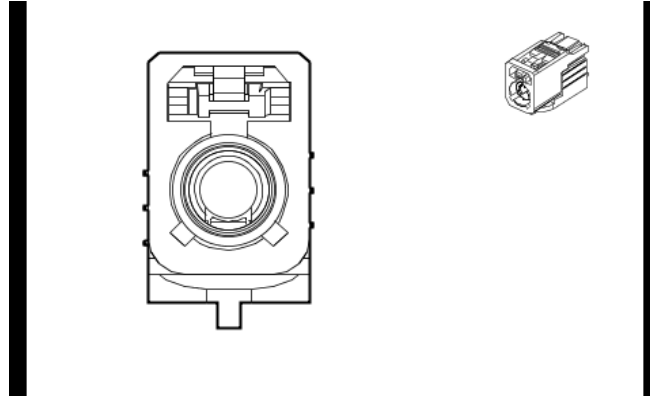

5661657

### Connector Part Information

Harness Type: Instrument Panel Wiring Harness COAX  
 OEM Connector: 33351022  
 Service Connector: Service by Cable Assembly — See Part Catalog  
 Description: 1-Way F Coax Type( YE)

### Terminal Part Information

Terminal Type ID	Terminated Lead	Diagnostic Test Probe	Terminal Removal Tool
I	Not required	No Tool Required	No Tool Required

### T4P High Frequency Antenna X2 (U2K)

Pin	Size	Color	Circuit	Function	Terminal Type ID	Option
—	—	Coax Cable	—	(XM +/-HD) Coaxial Antenna XM Signal	I	—

**T4TA Auxiliary Wireless Communication Interface Antenna**

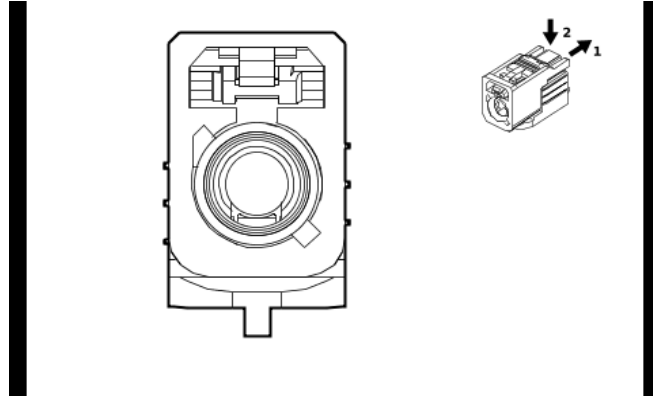

5518436

**Connector Part Information**

Harness Type: Instrument Panel Wiring Harness COAX  
 OEM Connector: 33351021  
 Service Connector: Service by Cable Assembly — See Part Catalog  
 Description: 1-Way F Coax Type( BG)

**Terminal Part Information**

Terminal Type ID	Terminated Lead	Diagnostic Test Probe	Terminal Removal Tool
I	Not required	No Tool Required	No Tool Required

**T4TA Auxiliary Wireless Communication Interface Antenna**

Pin	Size	Color	Circuit	Function	Terminal Type ID	Option
—	—	Coax Cable	—	WiFi Antenna Coaxial Signal	I	—

### T8A Ignition Coil 1 (L3B)

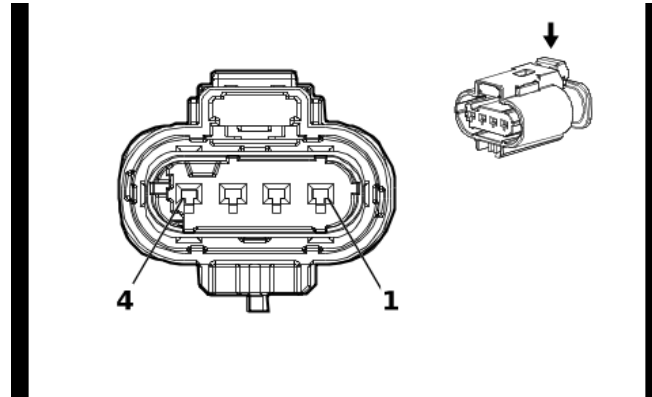

5402120

#### Connector Part Information

Harness Type: Engine Wiring Harness  
 OEM Connector: 10092979  
 Service Connector: Service by Harness - See Part Catalog  
 Description: 4-Way F 1.2 Multilock Series, Sealed( BK)

#### Terminal Part Information

Terminal Type ID	Terminated Lead	Diagnostic Test Probe	Terminal Removal Tool
I	Not required	J-35616-12 (BU)	No Tool Required

#### T8A Ignition Coil 1 (L3B)

Pin	Size	Color	Circuit	Function	Terminal Type ID	Option
1	1	BK	6450	Engine Even Bank Ground	I	—
2	0.75	BK / BU	2129	Ignition Control Low Reference Bank 1	I	—
3	0.75	BU / VT	2121	Ignition Control 1	I	—
4	1	VT / BU	5291	Powertrain Main Relay Fused Supply Voltage 2	I	—

### T8A Ignition Coil 1 (L84 / L87)

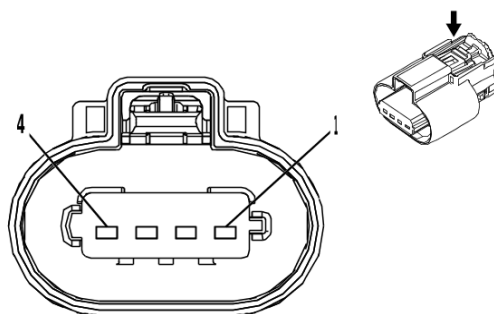

3240115

#### Connector Part Information

Harness Type: Engine Wiring Harness  
 OEM Connector: 34770-0402  
 Service Connector: 19367596  
 Description: 4-Way F 1.5 MX Series, Sealed( BK)

#### Terminal Part Information

Terminal Type ID	Terminated Lead	Diagnostic Test Probe	Terminal Removal Tool
I	Not required	J-35616-14 (GN)	No Tool Required
II	Not required	J-35616-2A (GY)	No Tool Required

#### T8A Ignition Coil 1 (L84 / L87)

Pin	Size	Color	Circuit	Function	Terminal Type ID	Option
1	1	BK	6150	Engine Odd Bank Ground	II	—
2	0.5	BK / BU	2129	Ignition Control Low Reference Bank 1	I	—
3	0.5	BU / VT	2121	Ignition Control 1	I	—
4	1	VT / BU	5291	Powertrain Main Relay Fused Supply Voltage 2	II	—

### T8B Ignition Coil 2 (L3B)

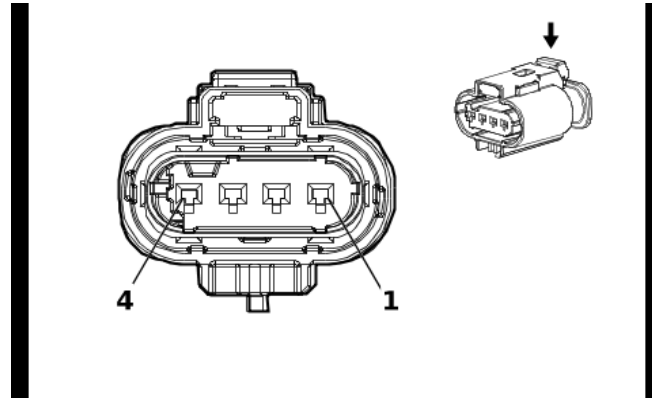

5402120

#### Connector Part Information

Harness Type: Engine Wiring Harness  
 OEM Connector: 10092979  
 Service Connector: Service by Harness - See Part Catalog  
 Description: 4-Way F 1.2 Multilock Series, Sealed( BK)

#### Terminal Part Information

Terminal Type ID	Terminated Lead	Diagnostic Test Probe	Terminal Removal Tool
I	Not required	J-35616-12 (BU)	No Tool Required

#### T8B Ignition Coil 2 (L3B)

Pin	Size	Color	Circuit	Function	Terminal Type ID	Option
1	1	BK	6450	Engine Even Bank Ground	I	—
2	0.75	BK / BU	2129	Ignition Control Low Reference Bank 1	I	—
3	0.75	BU / WH	2122	Ignition Control 2	I	—
4	1	VT / BU	5291	Powertrain Main Relay Fused Supply Voltage 2	I	—

**T8B Ignition Coil 2 (L84 / L87)**

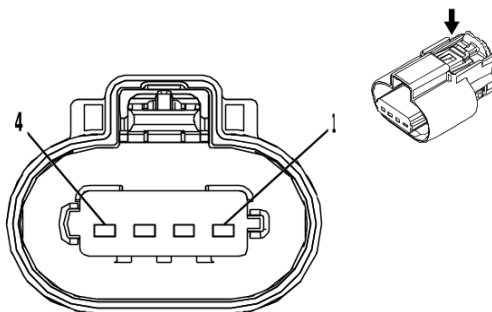

3240115

**Connector Part Information**

Harness Type: Engine Wiring Harness  
 OEM Connector: 34770-0402  
 Service Connector: 19367596  
 Description: 4-Way F 1.5 MX Series, Sealed( BK)

**Terminal Part Information**

Terminal Type ID	Terminated Lead	Diagnostic Test Probe	Terminal Removal Tool
I	Not required	J-35616-14 (GN)	No Tool Required
II	Not required	J-35616-2A (GY)	No Tool Required

**T8B Ignition Coil 2 (L84 / L87)**

Pin	Size	Color	Circuit	Function	Terminal Type ID	Option
1	1	BK	6450	Engine Even Bank Ground	II	—
2	0.5	BK / GY	2130	Ignition Control Low Reference Bank 2	I	—
3	0.5	BU / WH	2122	Ignition Control 2	I	—
4	1	VT / BU	5292	Powertrain Main Relay Fused Supply Voltage 3	II	—



### T8C Ignition Coil 3 (L3B)

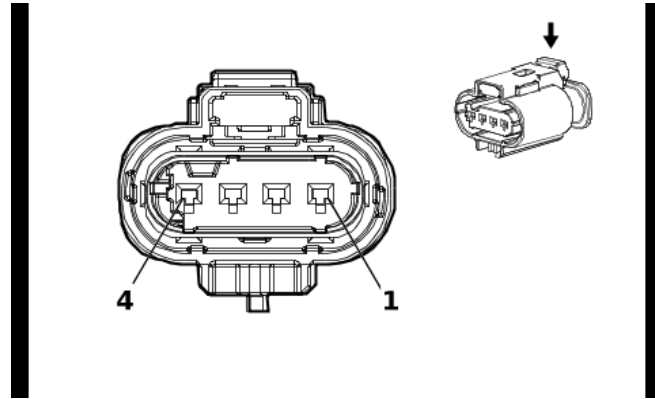

5402120

#### Connector Part Information

Harness Type: Engine Wiring Harness  
 OEM Connector: 10092979  
 Service Connector: Service by Harness - See Part Catalog  
 Description: 4-Way F 1.2 Multilock Series, Sealed( BK)

#### Terminal Part Information

Terminal Type ID	Terminated Lead	Diagnostic Test Probe	Terminal Removal Tool
I	Not required	J-35616-12 (BU)	No Tool Required

#### T8C Ignition Coil 3 (L3B)

Pin	Size	Color	Circuit	Function	Terminal Type ID	Option
1	1	BK	6450	Engine Even Bank Ground	I	—
2	0.75	BK / BU	2129	Ignition Control Low Reference Bank 1	I	—
3	0.75	GN / BU	2123	Ignition Control 3	I	—
4	1	VT / BU	5291	Powertrain Main Relay Fused Supply Voltage 2	I	—

**T8C Ignition Coil 3 (L84 / L87)**

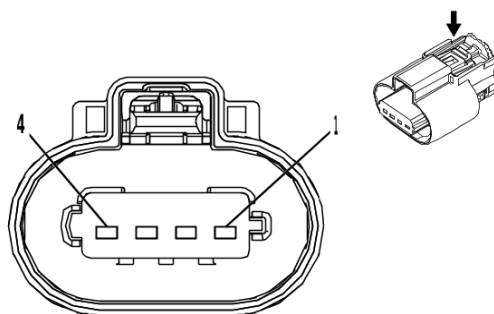

3240115

**Connector Part Information**

Harness Type: Engine Wiring Harness  
 OEM Connector: 34770-0402  
 Service Connector: 19367596  
 Description: 4-Way F 1.5 MX Series, Sealed( BK)

**Terminal Part Information**

Terminal Type ID	Terminated Lead	Diagnostic Test Probe	Terminal Removal Tool
I	Not required	J-35616-14 (GN)	No Tool Required
II	Not required	J-35616-2A (GY)	No Tool Required

**T8C Ignition Coil 3 (L84 / L87)**

Pin	Size	Color	Circuit	Function	Terminal Type ID	Option
1	1	BK	6150	Engine Odd Bank Ground	II	—
2	0.5	BK / BU	2129	Ignition Control Low Reference Bank 1	I	—
3	0.5	GN / BU	2123	Ignition Control 3	I	—
4	1	VT / BU	5291	Powertrain Main Relay Fused Supply Voltage 2	II	—

**T8D Ignition Coil 4 (L3B)**

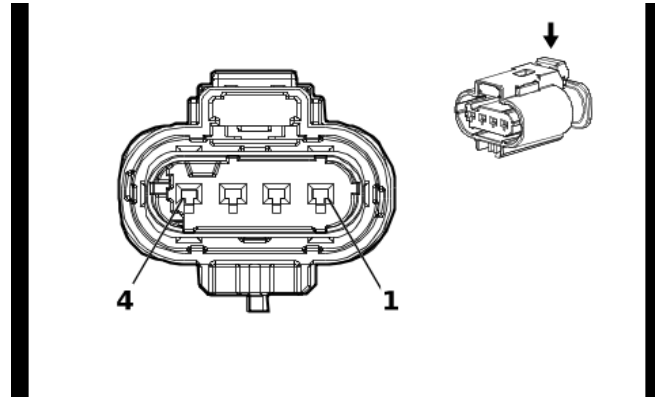

5402120

**Connector Part Information**

Harness Type: Engine Wiring Harness  
 OEM Connector: 10092979  
 Service Connector: Service by Harness - See Part Catalog  
 Description: 4-Way F 1.2 Multilock Series, Sealed( BK)

**Terminal Part Information**

Terminal Type ID	Terminated Lead	Diagnostic Test Probe	Terminal Removal Tool
I	Not required	J-35616-12 (BU)	No Tool Required

**T8D Ignition Coil 4 (L3B)**

Pin	Size	Color	Circuit	Function	Terminal Type ID	Option
1	1	BK	6450	Engine Even Bank Ground	I	—
2	0.75	BK / BU	2129	Ignition Control Low Reference Bank 1	I	—
3	0.75	YE / BU	2124	Ignition Control 4	I	—
4	1	VT / BU	5291	Powertrain Main Relay Fused Supply Voltage 2	I	—

**T8D Ignition Coil 4 (L84 / L87)**

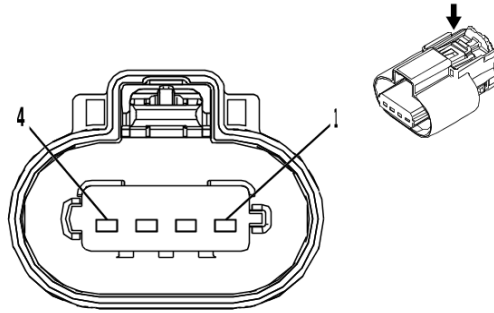

3240115

**Connector Part Information**

Harness Type: Engine Wiring Harness  
 OEM Connector: 34770-0402  
 Service Connector: 19367596  
 Description: 4-Way F 1.5 MX Series, Sealed( BK)

**Terminal Part Information**

Terminal Type ID	Terminated Lead	Diagnostic Test Probe	Terminal Removal Tool
I	Not required	J-35616-14 (GN)	No Tool Required
II	Not required	J-35616-2A (GY)	No Tool Required

**T8D Ignition Coil 4 (L84 / L87)**

Pin	Size	Color	Circuit	Function	Terminal Type ID	Option
1	1	BK	6450	Engine Even Bank Ground	II	—
2	0.5	BK / GY	2130	Ignition Control Low Reference Bank 2	I	—
3	0.5	YE / BU	2124	Ignition Control 4	I	—
4	1	VT / BU	5292	Powertrain Main Relay Fused Supply Voltage 3	II	—

## T8E Ignition Coil 5

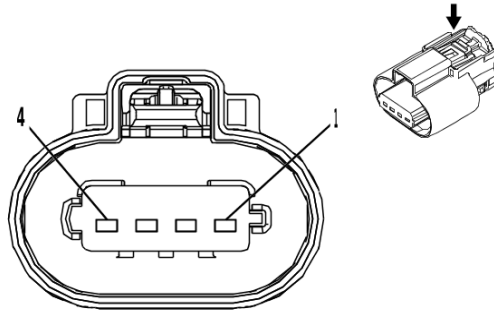

3240115

### Connector Part Information

Harness Type: Engine Wiring Harness  
 OEM Connector: 34770-0402  
 Service Connector: 19367596  
 Description: 4-Way F 1.5 MX Series, Sealed( BK)

### Terminal Part Information

Terminal Type ID	Terminated Lead	Diagnostic Test Probe	Terminal Removal Tool
I	Not required	J-35616-14 (GN)	No Tool Required
II	Not required	J-35616-2A (GY)	No Tool Required

### T8E Ignition Coil 5

Pin	Size	Color	Circuit	Function	Terminal Type ID	Option
1	1	BK	6150	Engine Odd Bank Ground	II	—
2	0.5	BK / BU	2129	Ignition Control Low Reference Bank 1	I	—
3	0.5	BU / GY	2125	Ignition Control 5	I	—
4	1	VT / BU	5291	Powertrain Main Relay Fused Supply Voltage 2	II	—

T8F Ignition Coil 6

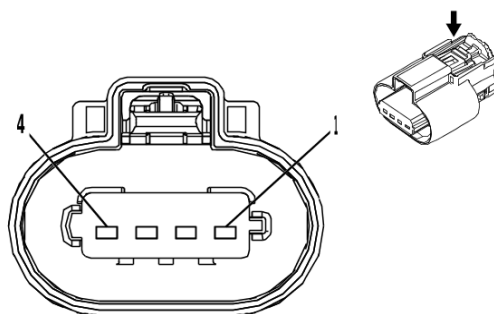

3240115

**Connector Part Information**

Harness Type: Engine Wiring Harness  
 OEM Connector: 34770-0402  
 Service Connector: 19367596  
 Description: 4-Way F 1.5 MX Series, Sealed( BK)

**Terminal Part Information**

Terminal Type ID	Terminated Lead	Diagnostic Test Probe	Terminal Removal Tool
I	Not required	J-35616-14 (GN)	No Tool Required
II	Not required	J-35616-2A (GY)	No Tool Required

**T8F Ignition Coil 6**

Pin	Size	Color	Circuit	Function	Terminal Type ID	Option
1	1	BK	6450	Engine Even Bank Ground	II	—
2	0.5	BK / GY	2130	Ignition Control Low Reference Bank 2	I	—
3	0.5	BN / BU	2126	Ignition Control 6	I	—
4	1	VT / BU	5292	Powertrain Main Relay Fused Supply Voltage 3	II	—

## T8G Ignition Coil 7

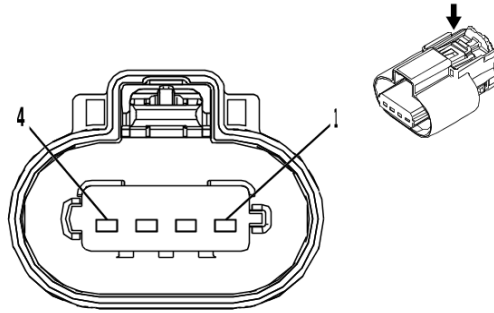

3240115

### Connector Part Information

Harness Type: Engine Wiring Harness  
 OEM Connector: 34770-0402  
 Service Connector: 19367596  
 Description: 4-Way F 1.5 MX Series, Sealed( BK)

### Terminal Part Information

Terminal Type ID	Terminated Lead	Diagnostic Test Probe	Terminal Removal Tool
I	Not required	J-35616-14 (GN)	No Tool Required
II	Not required	J-35616-2A (GY)	No Tool Required

### T8G Ignition Coil 7

Pin	Size	Color	Circuit	Function	Terminal Type ID	Option
1	1	BK	6150	Engine Odd Bank Ground	II	—
2	0.5	BK / BU	2129	Ignition Control Low Reference Bank 1	I	—
3	0.5	GN / GY	2127	Ignition Control 7	I	—
4	1	VT / BU	5291	Powertrain Main Relay Fused Supply Voltage 2	II	—

T8H Ignition Coil 8

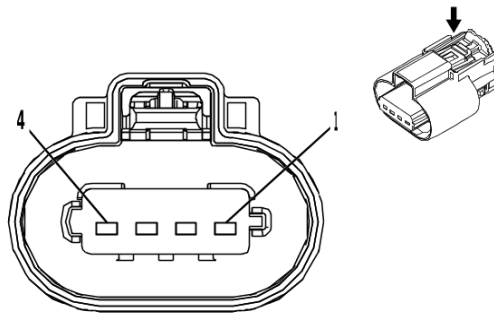

3240115

**Connector Part Information**

Harness Type: Engine Wiring Harness  
 OEM Connector: 34770-0402  
 Service Connector: 19367596  
 Description: 4-Way F 1.5 MX Series, Sealed( BK)

**Terminal Part Information**

Terminal Type ID	Terminated Lead	Diagnostic Test Probe	Terminal Removal Tool
I	Not required	J-35616-14 (GN)	No Tool Required
II	Not required	J-35616-2A (GY)	No Tool Required

**T8H Ignition Coil 8**

Pin	Size	Color	Circuit	Function	Terminal Type ID	Option
1	1	BK	6450	Engine Even Bank Ground	II	—
2	0.5	BK / GY	2130	Ignition Control Low Reference Bank 2	I	—
3	0.5	VT / WH	2128	Ignition Control 8	I	—
4	1	VT / BU	5292	Powertrain Main Relay Fused Supply Voltage 3	II	—



**T10G Low Frequency Rear Bumper Antenna (AVJ)**

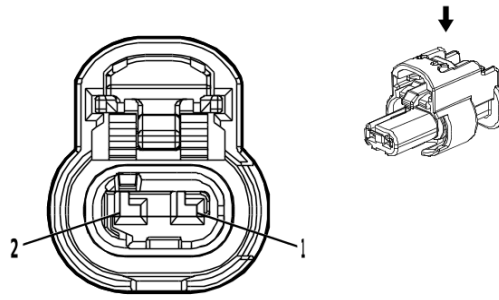

4690744

**Connector Part Information**

Harness Type: Chassis Wiring Harness  
 OEM Connector: 1-2296694-3  
 Service Connector: 19366871  
 Description: 2-Way F 1.2 MCON Series, Sealed( BK)

**Terminal Part Information**

Terminal Type ID	Terminated Lead	Diagnostic Test Probe	Terminal Removal Tool
I	Not required	J-35616-12 (BU)	No Tool Required

**T10G Low Frequency Rear Bumper Antenna (AVJ)**

Pin	Size	Color	Circuit	Function	Terminal Type ID	Option
1	0.5	BN / GN	3568	Rear Closure Passive Entry Antenna High Signal	I	—
2	0.5	GN / GY	3569	Rear Closure Passive Entry Antenna Low Signal	I	—

**T10J Low Frequency Instrument Panel Antenna (IOK)**

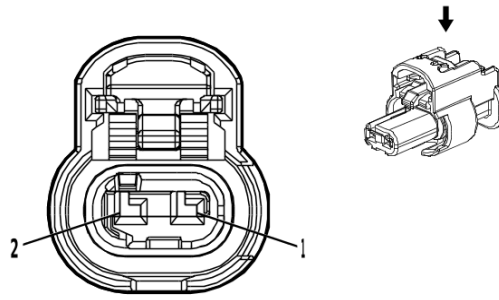

4690744

**Connector Part Information**

Harness Type: Instrument Panel Wiring Harness  
 OEM Connector: 1-2296694-3  
 Service Connector: 19366871  
 Description: 2-Way F 1.2 MCON Series, Sealed( BK)

**Terminal Part Information**

Terminal Type ID	Terminated Lead	Diagnostic Test Probe	Terminal Removal Tool
I	Not required	J-35616-12 (BU)	No Tool Required

**T10J Low Frequency Instrument Panel Antenna (IOK)**

Pin	Size	Color	Circuit	Function	Terminal Type ID	Option
1	0.35	BN / BK	3552	Interior Passive Entry Antenna 1 High Signal	I	—
2	0.35	WH	3553	Interior Passive Entry Antenna 1 Low Signal	I	—

**T10J Low Frequency Instrument Panel Antenna (IOR)**

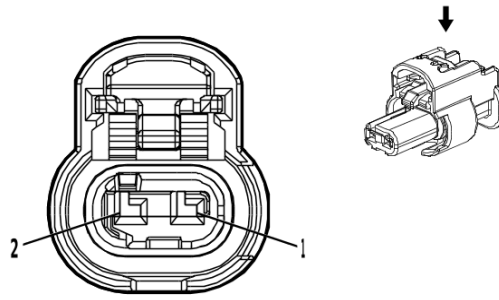

4690744

**Connector Part Information**

Harness Type: Instrument Panel Wiring Harness  
 OEM Connector: 1-2296694-3  
 Service Connector: 19366871  
 Description: 2-Way F 1.2 MCON Series, Sealed( BK)

**Terminal Part Information**

Terminal Type ID	Terminated Lead	Diagnostic Test Probe	Terminal Removal Tool
I	Not required	J-35616-12 (BU)	No Tool Required

**T10J Low Frequency Instrument Panel Antenna (IOR)**

Pin	Size	Color	Circuit	Function	Terminal Type ID	Option
1	0.35	BN / BK	3552	Interior Passive Entry Antenna 1 High Signal	I	—
2	0.35	WH	3553	Interior Passive Entry Antenna 1 Low Signal	I	—

T10UA Low Frequency Console Antenna (AZ3)

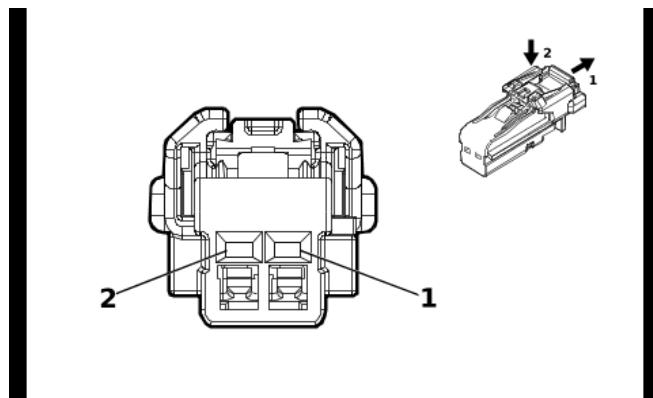

4115691

**Connector Part Information**

Harness Type: Front Seat Wiring Harness - Center  
 OEM Connector: 6098-8988  
 Service Connector: Service by Harness - See Part Catalog  
 Description: 2-Way F 1.2 MCON Series( BK)

**Terminal Part Information**

Terminal Type ID	Terminated Lead	Diagnostic Test Probe	Terminal Removal Tool
I	Not required	J-35616-16 (L-GN)	No Tool Required

**T10UA Low Frequency Console Antenna (AZ3)**

Pin	Size	Color	Circuit	Function	Terminal Type ID	Option
1	0.5	BN / BK	4996	Immobilizer Antenna Signal [+]	I	—
2	0.5	WH / GY	4997	Immobilizer Antenna Low Signal	I	—

**T10UA Low Frequency Console Antenna (D07)**

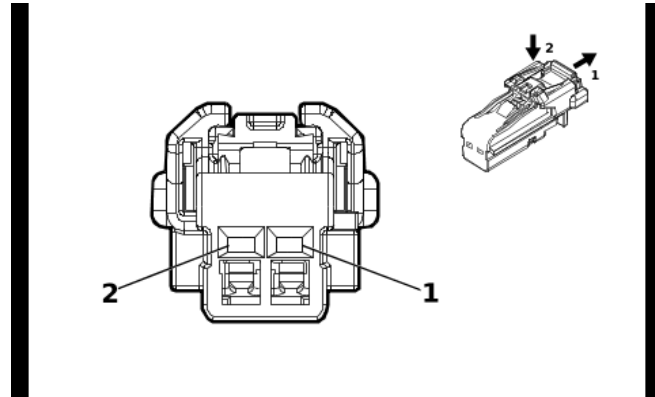

4115691

**Connector Part Information**

Harness Type: Front Floor Console Wiring Harness  
 OEM Connector: 6098-8988  
 Service Connector: Service by Harness - See Part Catalog  
 Description: 2-Way F 1.2 MCON Series( BK)

**Terminal Part Information**

Terminal Type ID	Terminated Lead	Diagnostic Test Probe	Terminal Removal Tool
I	Not required	J-35616-12 (BU)	No Tool Required

**T10UA Low Frequency Console Antenna (D07)**

Pin	Size	Color	Circuit	Function	Terminal Type ID	Option
1	0.35	BN / BK	4996	Immobilizer Antenna Signal [+]	I	—
2	0.35	WH / GY	4997	Immobilizer Antenna Low Signal	I	—

T12 Automatic Transmission X1

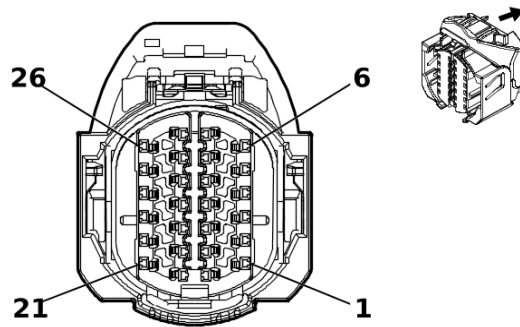

5275597

**Connector Part Information**

Harness Type: Engine Wiring Harness  
 OEM Connector: 2327375-1  
 Service Connector: 13528029  
 Description: 26-Way F 1.2 MCON Series, Sealed( BK)

**Terminal Part Information**

Terminal Type ID	Terminated Lead	Diagnostic Test Probe	Terminal Removal Tool
I	19331733	J-35616-12 (BU)	J-38125-215A
II	84963773	J-35616-12 (BU)	J-38125-215A

**T12 Automatic Transmission X1**

Pin	Size	Color	Circuit	Function	Terminal Type ID	Option
1	0.5	GN / YE	6353	Input Speed Signal	I	—
2	0.5	GN / VT	4510	Transmission Intermediate Speed Signal	I	—
3	0.5	BN / WH	6254	Transmission Input Speed Sensor Signal	I	—
4	0.5	GY / BU	6358	Output Speed Signal	I	—
5	0.5	BU / WH	3338	Transmission Internal Mode Switch Mode Control X	I	—
6	0.5	GN / YE	3337	Transmission Internal Mode Switch Mode Control Y	I	—
7	0.5	YE / GN	4170	Transmission Output Shaft Speed Sensor Circuit 9V Reference	I	—
8	0.5	YE / BU	4171	Transmission Input Shaft Speed Sensor Circuit 9V Reference	I	—
9	0.5	GY / BN	6388	Transmission High Side Driver 2 Control	I	—
10	1.5	RD / GY	8540	Battery Positive Voltage	II	—
11	0.5	GN / GY	6387	Transmission High Side Driver 1 Control	I	—
12	0.5	WH / RD	480	Engine Control Vehicle Sensors 5 Volt Reference 1	I	—
13	0.5	BN / WH	585	Transmission Fluid Temperature Sensor Signal	I	—
14	0.5	YE / BN	6404	Clutch Solenoid Valve E Control	I	—
15	0.5	GY / GN	6403	Clutch Solenoid Valve D Control	I	—
16	0.5	GY	6402	Clutch Solenoid Valve C Control	I	—
17	1.5	BK	450	Ground	II	—
18	0.5	GN / WH	2968	Transmission Auxiliary Fluid Pump Control	I	—

**T12 Automatic Transmission X1 (cont'd)**

<b>Pin</b>	<b>Size</b>	<b>Color</b>	<b>Circuit</b>	<b>Function</b>	<b>Terminal Type ID</b>	<b>Option</b>
19	0.5	GN / BK	7819	Default Disable Solenoid Control		—
20	0.5	BK / GY	626	Engine Control Vehicle Sensors Low Reference 1		—
21	0.5	VT	4509	Transmission Clutch F Control		—
22	0.5	WH / BU	4507	Transmission Clutch H Control		—
23	0.5	WH	4508	Transmission Clutch G Control		—
24	0.5	GN / WH	1530	Transmission Line Pressure Control Solenoid Valve Control		—
25	0.5	VT / WH	422	Torque Converter Clutch Solenoid Valve Control		—
26	0.5	BK / BN	586	Transmission Fluid Temperature Sensor Low Reference		—

**T12 Automatic Transmission X2 (MHT / MI2 / MQB)**

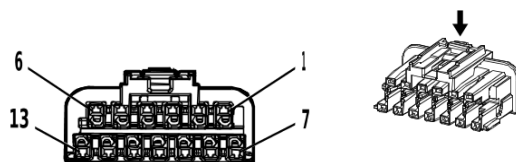

4757907

**Connector Part Information**

Harness Type: Automatic Transmission Wiring Harness - Case  
 OEM Connector: 2203990-1  
 Service Connector: Service by Harness - See Part Catalog  
 Description: 13-Way F 1.2 MCON Series( BN)

**Terminal Part Information**

Terminal Type ID	Terminated Lead	Diagnostic Test Probe	Terminal Removal Tool
I	Not required	J-35616-12 (BU)	No Tool Required
II	Not required	J-35616-16 (L-GN)	No Tool Required

**T12 Automatic Transmission X2 (MHT / MI2 / MQB)**

Pin	Size	Color	Circuit	Function	Terminal Type ID	Option
1	0.5	YE / GY	3337	Transmission Internal Mode Switch Mode Control Y	II	—
2	0.5	YE	3338	Transmission Internal Mode Switch Mode Control X	II	—
3	0.5	YE / OG	6358	Output Speed Signal	I	—
4	0.5	WH / BU	6254	Transmission Input Speed Sensor Signal	I	—
5	0.5	VT / GN	4510	Transmission Intermediate Speed Signal	I	—
6	0.5	WH / VT	6353	Input Speed Signal	I	—
7	0.5	BN / YE	585	Transmission Fluid Temperature Sensor Signal	I	—
8	0.5	OG	480	Engine Control Vehicle Sensors 5 Volt Reference 1	I	—
9	0.5	BN	6387	Transmission High Side Driver 1 Control	I	—
10	1.5	GN / VT	8540	Battery Positive Voltage	I	—
11	0.5	WH	6388	Transmission High Side Driver 2 Control	I	—
12	0.5	BU	4171	Transmission Input Shaft Speed Sensor Circuit 9V Reference	I	—
13	0.5	GN	4170	Transmission Output Shaft Speed Sensor Circuit 9V Reference	I	—



## T12 Automatic Transmission X2 (MQC / MHS)

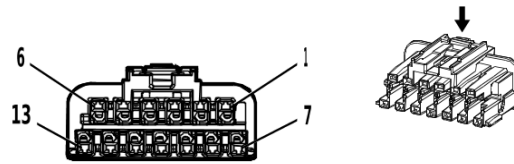

4757907

### Connector Part Information

Harness Type: Automatic Transmission Wiring Harness - Case  
 OEM Connector: 2203990-1  
 Service Connector: Service by Harness - See Part Catalog  
 Description: 13-Way F 1.2 MCON Series( BN)

### Terminal Part Information

Terminal Type ID	Terminated Lead	Diagnostic Test Probe	Terminal Removal Tool
I	Not required	J-35616-12 (BU)	No Tool Required
II	Not required	J-35616-16 (L-GN)	No Tool Required

### T12 Automatic Transmission X2 (MQC / MHS)

Pin	Size	Color	Circuit	Function	Terminal Type ID	Option
1	0.5	YE / GY	6319	Electronic Transmission Range Select Out of Park Switch 2 Signal	II	—
2	0.5	YE	6317	Electronic Transmission Range Select Out of Park Switch Signal	II	—
3	0.5	YE / OG	6358	Output Speed Signal	I	—
4	0.5	WH / BU	6254	Transmission Input Speed Sensor Signal	I	—
5	0.5	VT / GN	4510	Transmission Intermediate Speed Signal	I	—
6	0.5	WH / VT	6353	Input Speed Signal	I	—
7	0.5	BN / YE	585	Transmission Fluid Temperature Sensor Signal	I	—
8	0.5	OG	2159	Park Inhibit Solenoid Assembly Control	I	—
9	0.5	BN	6387	Transmission High Side Driver 1 Control	I	—
10	1.5	GN / VT	8540	Battery Positive Voltage	I	—
11	0.5	WH	6388	Transmission High Side Driver 2 Control	I	—
12	0.5	BU	4171	Transmission Input Shaft Speed Sensor Circuit 9V Reference	I	—
13	0.5	GN	4170	Transmission Output Shaft Speed Sensor Circuit 9V Reference	I	—

**T12 Automatic Transmission X3 (MHS / MQC)**

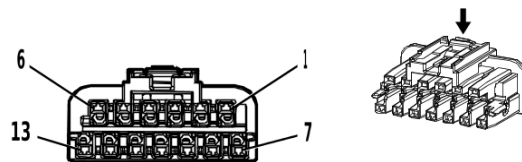

4757999

**Connector Part Information**

Harness Type: Automatic Transmission Wiring Harness - Case  
 OEM Connector: 2203990-2  
 Service Connector: Service by Harness - See Part Catalog  
 Description: 13-Way F 1.2 MCON Series( BN)

**Terminal Part Information**

Terminal Type ID	Terminated Lead	Diagnostic Test Probe	Terminal Removal Tool
I	Not required	J-35616-12 (BU)	No Tool Required

**T12 Automatic Transmission X3 (MHS / MQC)**

Pin	Size	Color	Circuit	Function	Terminal Type ID	Option
1	0.5	BN / WH	4509	Transmission Clutch F Control	I	—
2	0.5	YE / VT	4507	Transmission Clutch H Control	I	—
3	0.5	BU / GY	4508	Transmission Clutch G Control	I	—
4	0.5	GN / OG	1530	Transmission Line Pressure Control Solenoid Valve Control	I	—
5	0.5	GY / BN	422	Torque Converter Clutch Solenoid Valve Control	I	—
6	0.5	BU / BN	586	Transmission Fluid Temperature Sensor Low Reference	I	—
7	0.5	BU / GN	6404	Clutch Solenoid Valve E Control	I	—
8	0.5	GN / BN	6403	Clutch Solenoid Valve D Control	I	—
9	0.5	GY	6402	Clutch Solenoid Valve C Control	I	—
10	1.5	BK / YE	450	Ground	I	—
11	0.5	GY / OG	2968	Transmission Auxiliary Fluid Pump Control	I	—
12	0.5	VT	7819	Default Disable Solenoid Control	I	—
13	0.5	BK / GY	3706	Electronic Transmission Range Select Switch Analog Signal 1	I	—

**T12 Automatic Transmission X3 (MHT / MI2 / MQB)**

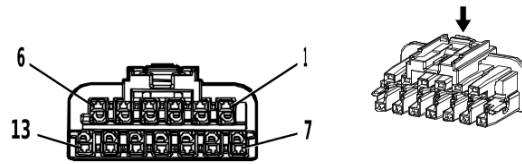

4757999

**Connector Part Information**

Harness Type: Automatic Transmission Wiring Harness - Case  
 OEM Connector: 2203990-2  
 Service Connector: Service by Harness - See Part Catalog  
 Description: 13-Way F 1.2 MCON Series( BN)

**Terminal Part Information**

Terminal Type ID	Terminated Lead	Diagnostic Test Probe	Terminal Removal Tool
I	Not required	J-35616-12 (BU)	No Tool Required

**T12 Automatic Transmission X3 (MHT / MI2 / MQB)**

Pin	Size	Color	Circuit	Function	Terminal Type ID	Option
1	0.5	BN / WH	4509	Transmission Clutch F Control	I	—
2	0.5	YE / VT	4507	Transmission Clutch H Control	I	—
3	0.5	BU / GY	4508	Transmission Clutch G Control	I	—
4	0.5	GN / OG	1530	Transmission Line Pressure Control Solenoid Valve Control	I	—
5	0.5	GY / BN	422	Torque Converter Clutch Solenoid Valve Control	I	—
6	0.5	BU / BN	586	Transmission Fluid Temperature Sensor Low Reference	I	—
7	0.5	BU / GN	6404	Clutch Solenoid Valve E Control	I	—
8	0.5	GN / BN	6403	Clutch Solenoid Valve D Control	I	—
9	0.5	GY	6402	Clutch Solenoid Valve C Control	I	—
10	1.5	BK / YE	450	Ground	I	—
11	0.5	GY / OG	2968	Transmission Auxiliary Fluid Pump Control	I	—
12	0.5	VT	7819	Default Disable Solenoid Control	I	—
13	0.5	BK / GY	626	Engine Control Vehicle Sensors Low Reference 1	I	—

T19 Multifunction Power Supply Converter

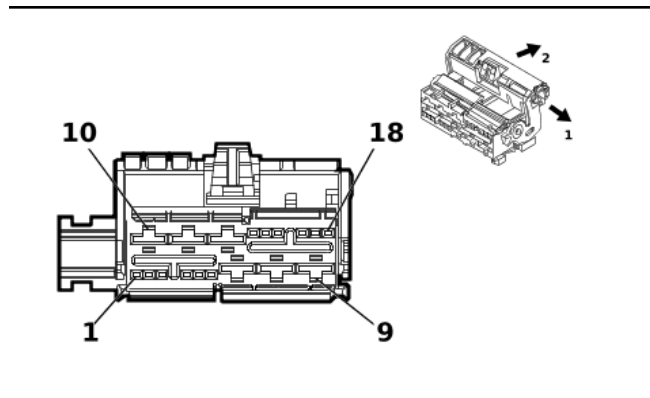

3825662

Connector Part Information

Harness Type: Body Wiring Harness  
 OEM Connector: 35509388  
 Service Connector: 13549243  
 Description: 18-Way F 0.64 MTS, 6.3 MCP Series( BK)

Terminal Part Information

Terminal Type ID	Terminated Lead	Diagnostic Test Probe	Terminal Removal Tool
I	19300632	J-35616-64B (L-BU)	J-38125-215A
II	19367600	J-35616-42 (RD)	J-38125-556

T19 Multifunction Power Supply Converter

Pin	Size	Color	Circuit	Function	Terminal Type ID	Option
1 - 3	—	—	—	Not Occupied	—	—
4	0.5 0.35	VT / GN VT / GN	4320 4320	Powertrain Sensor Bus Enable Powertrain Sensor Bus Enable	I I	D07+ FHX+ ( MQC/ MHS) D07+ FJW- L3B- L84- L87+ ( MQC/ MHS)
5	0.5	YE / BK	625	Starter Enable Relay Control	I	—
6	—	—	—	Not Occupied	—	—
7	2.5	BK	1350	Ground	II	—
8	2.5	RD / YE	8140	Battery Positive Voltage	II	—
9	2.5	RD / GN	2173	12V Regulated Supply Voltage 2	II	—
10	2.5	RD / YE	2172	12V Regulated Supply Voltage 1	II	—
11	2.5	RD / WH	8040	Battery Positive Voltage	II	—
12	2.5	BK	1350	Ground	II	—
13	0.5	BU / GY	4054	Private Serial Data Powertrain CAN Bus [-] Serial Data	I	—
14	0.5	BU / GY	4054	Private Serial Data Powertrain CAN Bus [-] Serial Data	I	—
15	0.5	WH	4055	Private Serial Data Powertrain CAN Bus [+] Serial Data	I	—
16	0.5	WH	4055	Private Serial Data Powertrain CAN Bus [+] Serial Data	I	—
17 - 18	—	—	—	Not Occupied	—	—

## T22 Wireless Accessory Charging Module

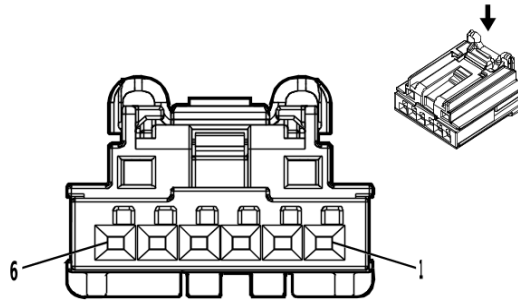

5020940

### Connector Part Information

Harness Type: Front Floor Console Wiring Harness  
 OEM Connector: 2035363-6  
 Service Connector: Service by Harness - See Part Catalog  
 Description: 6-Way F 0.64 Generation Y Series( BK)

### Terminal Part Information

Terminal Type ID	Terminated Lead	Diagnostic Test Probe	Terminal Removal Tool
I	Not required	J-35616-64B (L-BU)	No Tool Required

### T22 Wireless Accessory Charging Module

Pin	Size	Color	Circuit	Function	Terminal Type ID	Option
1	0.5	RD / VT	2640	Battery Positive Voltage	I	—
2	0.5	BK	1350	Ground	I	—
3	0.5	BU / YE	4984	AUTOSAR CAN Bus [-] 5 Serial Data	I	—
4	0.5	BU / WH	4985	AUTOSAR CAN Bus [+] 5 Serial Data	I	—
5	0.5	BU / YE	4984	AUTOSAR CAN Bus [-] 5 Serial Data	I	—
6	0.5	BU / WH	4985	AUTOSAR CAN Bus [+] 5 Serial Data	I	—

**X80G Accessory Power Receptacle - Instrument Panel (KC5)**

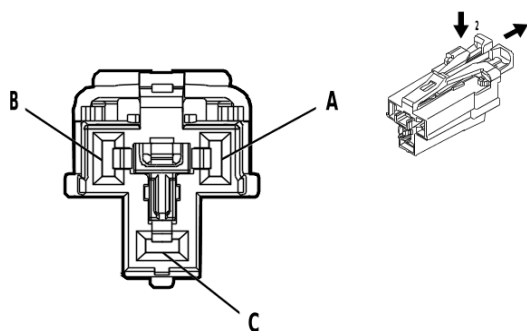

4872413

**Connector Part Information**

Harness Type: Instrument Panel Wiring Harness  
 OEM Connector: 33386302  
 Service Connector: 19369281  
 Description: 3-Way F 2.8 APEX Series( GY)

**Terminal Part Information**

Terminal Type ID	Terminated Lead	Diagnostic Test Probe	Terminal Removal Tool
I	Not required	J-35616-35 (VT)	No Tool Required

**X80G Accessory Power Receptacle - Instrument Panel (KC5)**

Pin	Size	Color	Circuit	Function	Terminal Type ID	Option
A	1.5	VT	1001	Retained Accessory Power Ignition Voltage	I	—
B	—	—	—	Not Occupied	—	—
C	1.5	BK	1050	Ground	I	—

**X81ACA Front Floor Console Accessory Power Rear Receptacle - 110V AC (KI4)**

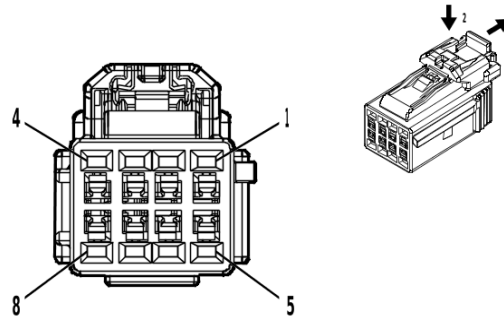

5086387

**Connector Part Information**

Harness Type: Front Floor Console Wiring Harness  
 OEM Connector: 6098-8443  
 Service Connector: Service by Harness - See Part Catalog  
 Description: 8-Way F 1.2 Series( BK)

**Terminal Part Information**

Terminal Type ID	Terminated Lead	Diagnostic Test Probe	Terminal Removal Tool
I	Not required	J-35616-12 (BU)	No Tool Required
II	Not required	J-35616-16 (L-GN)	No Tool Required

**X81ACA Front Floor Console Accessory Power Rear Receptacle - 110V AC (KI4)**

Pin	Size	Color	Circuit	Function	Terminal Type ID	Option
1	0.75	BK	10117	AC Outlet Phase A Control	II	—
2	—	—	—	Not Occupied	—	—
3	0.5	VT / RD	4049	AC Power Outlet Sensor High Reference	II	—
4	0.5	BU / BN	6807	DC/AC Inverter Control	II	—
5	0.75	RD	10118	AC Outlet Phase B Control	II	—
6	—	—	—	Not Occupied	—	—
7	0.5	BK	1350	Ground	II	—
8	0.35	YE	6817	LED Backlight Dimming Control 1	I	—

**X81AP Pickup Box Accessory Power Receptacle - 110V AC (KC9)**

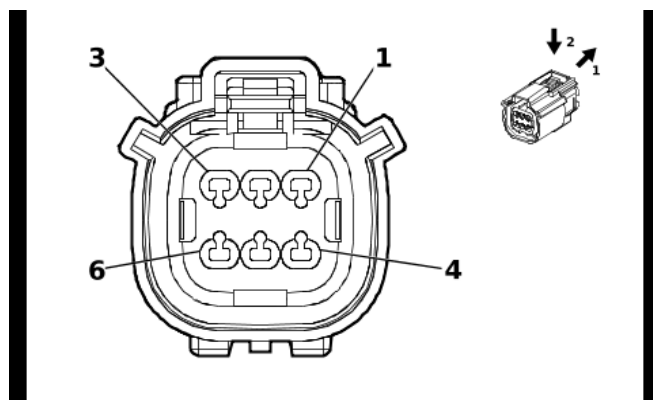

5666225

**Connector Part Information**

Harness Type: Chassis Rear Wiring Harness  
 OEM Connector: 33472-0744  
 Service Connector: Service by Harness - See Part Catalog  
 Description: 6-Way F 1.5 MX Series, Sealed( BK)

**Terminal Part Information**

Terminal Type ID	Terminated Lead	Diagnostic Test Probe	Terminal Removal Tool
I	Not required	J-35616-2A (GY)	No Tool Required

**X81AP Pickup Box Accessory Power Receptacle - 110V AC (KC9)**

Pin	Size	Color	Circuit	Function	Terminal Type ID	Option
1	0.5	VT / RD	4049	AC Power Outlet Sensor High Reference	I	—
2	0.5	GN / BN	2266	DC/AC Inverter Control 2	I	—
3	—	—	—	Not Occupied	—	—
4	0.75	BK / WH	10120	AC Outlet 2 Phase A Control	I	—
5	0.5	BK	1750	Ground	I	—
6	0.75	RD / WH	10121	AC Outlet 2 Phase B Control	I	—



**X81BCA Front Floor Console Accessory Power Rear Receptacle - 220V AC (KI5)**

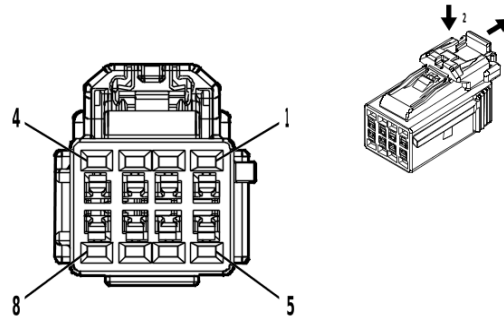

5086387

**Connector Part Information**

Harness Type: Front Floor Console Wiring Harness  
 OEM Connector: 6098-8443  
 Service Connector: Service by Harness - See Part Catalog  
 Description: 8-Way F 1.2 Series( BK)

**Terminal Part Information**

Terminal Type ID	Terminated Lead	Diagnostic Test Probe	Terminal Removal Tool
I	Not required	J-35616-12 (BU)	No Tool Required
II	Not required	J-35616-16 (L-GN)	No Tool Required

**X81BCA Front Floor Console Accessory Power Rear Receptacle - 220V AC (KI5)**

Pin	Size	Color	Circuit	Function	Terminal Type ID	Option
1	0.75	BK	10117	AC Outlet Phase A Control	II	—
2	—	—	—	Not Occupied	—	—
3	0.5	VT / RD	4049	AC Power Outlet Sensor High Reference	II	—
4	0.5	BU / BN	6807	DC/AC Inverter Control	II	—
5	0.75	RD	10118	AC Outlet Phase B Control	II	—
6	—	—	—	Not Occupied	—	—
7	0.5	BK	1350	Ground	II	—
8	0.35	YE	6817	LED Backlight Dimming Control 1	I	—

**X81BCA Front Floor Console Accessory Power Rear Receptacle - 220V AC (KI5 & D07)**

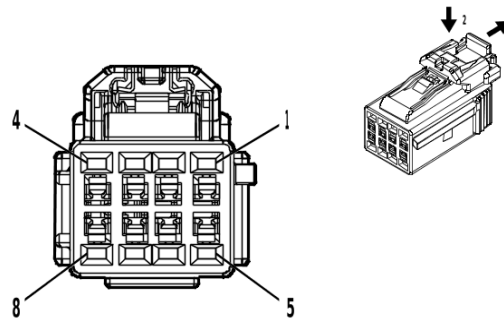

5086387

**Connector Part Information**

Harness Type: Front Floor Console Wiring Harness  
 OEM Connector: 35029311  
 Service Connector: Service by Harness - See Part Catalog  
 Description: 8-Way F 1.2 Series( BK)

**Terminal Part Information**

Terminal Type ID	Terminated Lead	Diagnostic Test Probe	Terminal Removal Tool
I	Not required	J-35616-12 (BU)	No Tool Required
II	Not required	J-35616-16 (L-GN)	No Tool Required

**X81BCA Front Floor Console Accessory Power Rear Receptacle - 220V AC (KI5 & D07)**

Pin	Size	Color	Circuit	Function	Terminal Type ID	Option
1	0.75	BK	10117	AC Outlet Phase A Control	II	—
2	—	—	—	Not Occupied	—	—
3	0.5	VT / RD	4049	AC Power Outlet Sensor High Reference	II	—
4	0.5	BU / BN	6807	DC/AC Inverter Control	II	—
5	0.75	RD	10118	AC Outlet Phase B Control	II	—
6	—	—	—	Not Occupied	—	—
7	0.5	BK	1350	Ground	II	—
8	0.35	YE	6817	LED Backlight Dimming Control 1	I	—

**X81BI Accessory Power Receptacle - Instrument Panel 220V AC (KI5 - AZ3 - D07)**

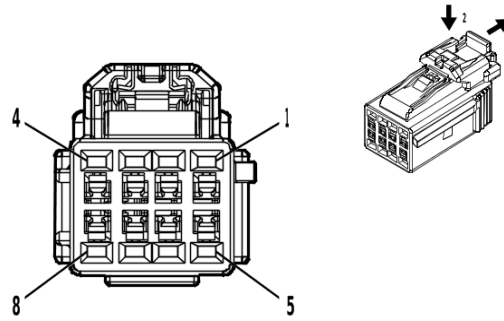

5086387

**Connector Part Information**

Harness Type: Instrument Panel Wiring Harness  
 OEM Connector: 35029311  
 Service Connector: 84613126  
 Description: 8-Way F 1.2 Series( BK)

**Terminal Part Information**

Terminal Type ID	Terminated Lead	Diagnostic Test Probe	Terminal Removal Tool
I	Not required	J-35616-12 (BU)	No Tool Required
II	Not required	J-35616-16 (L-GN)	No Tool Required

**X81BI Accessory Power Receptacle - Instrument Panel 220V AC (KI5 - AZ3 - D07)**

Pin	Size	Color	Circuit	Function	Terminal Type ID	Option
1	0.75	BK	10117	AC Outlet Phase A Control	II	—
2	—	—	—	Not Occupied	—	—
3	0.5	VT / RD	4049	AC Power Outlet Sensor High Reference	II	—
4	0.5	BU / BN	6807	DC/AC Inverter Control	II	—
5	0.75	RD	10118	AC Outlet Phase B Control	II	—
6	—	—	—	Not Occupied	—	—
7	0.5	BK / WH	851	Signal Ground	II	—
8	0.35	YE	6817	LED Backlight Dimming Control 1	I	—

**X81BP Pickup Box Accessory Power Receptacle - 220V AC (KCA)**

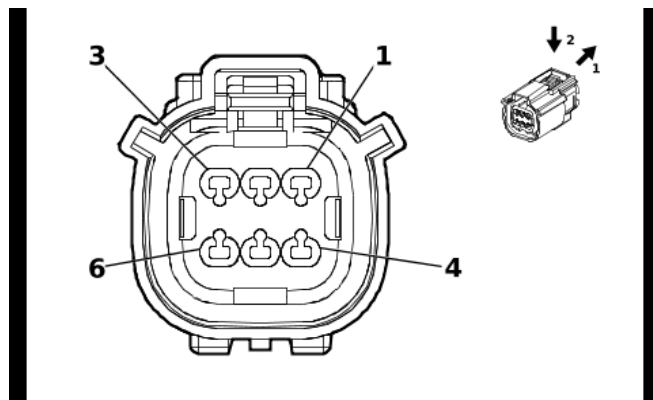

5666225

**Connector Part Information**

Harness Type: Chassis Rear Wiring Harness  
 OEM Connector: 33472-0744  
 Service Connector: Service by Harness - See Part Catalog  
 Description: 6-Way F 1.5 MX Series, Sealed( BK)

**Terminal Part Information**

Terminal Type ID	Terminated Lead	Diagnostic Test Probe	Terminal Removal Tool
I	Not required	J-35616-2A (GY)	No Tool Required

**X81BP Pickup Box Accessory Power Receptacle - 220V AC (KCA)**

Pin	Size	Color	Circuit	Function	Terminal Type ID	Option
1	0.5	VT / RD	4049	AC Power Outlet Sensor High Reference	I	—
2	0.5	GN / BN	2266	DC/AC Inverter Control 2	I	—
3	—	—	—	Not Occupied	—	—
4	0.75	BK / WH	10120	AC Outlet 2 Phase A Control	I	—
5	0.5	BK	1750	Ground	I	—
6	0.75	RD / WH	10121	AC Outlet 2 Phase B Control	I	—

**X81FSA Accessory Power Receptacle - Front Center Seat Rear Cover 110V AC (KI4)**

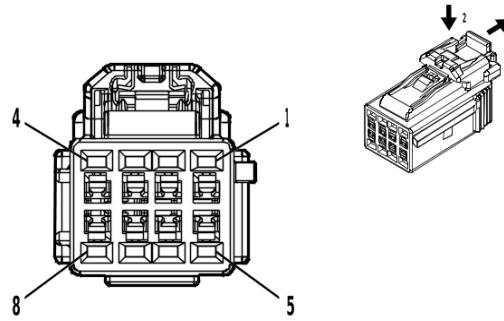

5086387

**Connector Part Information**

Harness Type: Front Seat Wiring Harness - Center  
 OEM Connector: 6098-8443  
 Service Connector: Service by Harness - See Part Catalog  
 Description: 8-Way F 1.2 Series( BK)

**Terminal Part Information**

Terminal Type ID	Terminated Lead	Diagnostic Test Probe	Terminal Removal Tool
I	Not required	J-35616-16 (L-GN)	No Tool Required

**X81FSA Accessory Power Receptacle - Front Center Seat Rear Cover 110V AC (KI4)**

Pin	Size	Color	Circuit	Function	Terminal Type ID	Option
1	0.75	BK	10117	AC Outlet Phase A Control	I	—
2	—	—	—	Not Occupied	—	—
3	0.75	VT / RD	4049	AC Power Outlet Sensor High Reference	I	—
4	0.75	BU / BN	6807	DC/AC Inverter Control	I	—
5	0.75	RD	10118	AC Outlet Phase B Control	I	—
6	—	—	—	Not Occupied	—	—
7	0.75	BK	1050	Ground	I	—
8	0.35	YE	6817	LED Backlight Dimming Control 1	I	—

**X81FSA Accessory Power Receptacle - Front Center Seat Rear Cover 110V AC (KI4 / KI5)**

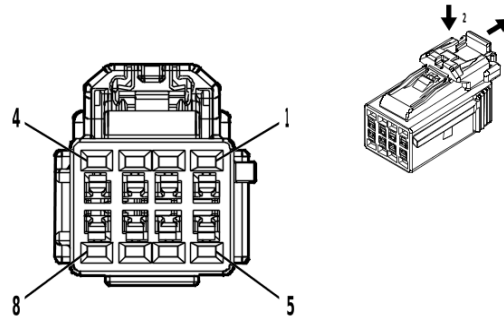

5086387

**Connector Part Information**

Harness Type: Instrument Panel Wiring Harness  
 OEM Connector: 6098-8443  
 Service Connector: 84613126  
 Description: 8-Way F 1.2 Series( BK)

**Terminal Part Information**

Terminal Type ID	Terminated Lead	Diagnostic Test Probe	Terminal Removal Tool
I	Not required	J-35616-12 (BU)	No Tool Required
II	Not required	J-35616-16 (L-GN)	No Tool Required

**X81FSA Accessory Power Receptacle - Front Center Seat Rear Cover 110V AC (KI4 / KI5)**

Pin	Size	Color	Circuit	Function	Terminal Type ID	Option
1	0.75	BK	10117	AC Outlet Phase A Control	II	—
2	—	—	—	Not Occupied	—	—
3	0.5	VT / RD	4049	AC Power Outlet Sensor High Reference	II	—
4	0.5	BU / BN	6807	DC/AC Inverter Control	II	—
5	0.75	RD	10118	AC Outlet Phase B Control	II	—
6	—	—	—	Not Occupied	—	—
7	0.5	BK / WH	851	Signal Ground	II	—
8	0.35	YE	6817	LED Backlight Dimming Control 1	I	—

**X81FSB Accessory Power Receptacle - Front Center Seat Rear Cover 220V AC (KI5)**

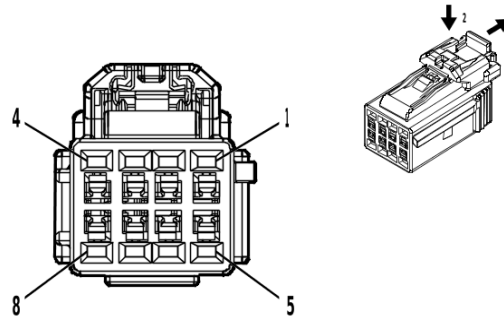

5086387

**Connector Part Information**

Harness Type: Front Seat Wiring Harness - Center  
 OEM Connector: 6098-8443  
 Service Connector: Service by Harness - See Part Catalog  
 Description: 8-Way F 1.2 Series( BK)

**Terminal Part Information**

Terminal Type ID	Terminated Lead	Diagnostic Test Probe	Terminal Removal Tool
I	Not required	J-35616-16 (L-GN)	No Tool Required

**X81FSB Accessory Power Receptacle - Front Center Seat Rear Cover 220V AC (KI5)**

Pin	Size	Color	Circuit	Function	Terminal Type ID	Option
1	0.75	BK	10117	AC Outlet Phase A Control	I	—
2	—	—	—	Not Occupied	—	—
3	0.75	VT / RD	4049	AC Power Outlet Sensor High Reference	I	—
4	0.75	BU / BN	6807	DC/AC Inverter Control	I	—
5	0.75	RD	10118	AC Outlet Phase B Control	I	—
6	—	—	—	Not Occupied	—	—
7	0.75	BK	1050	Ground	I	—
8	0.35	YE	6817	LED Backlight Dimming Control 1	I	—

**X83B Audio/Video Receptacle X1 (D07)**

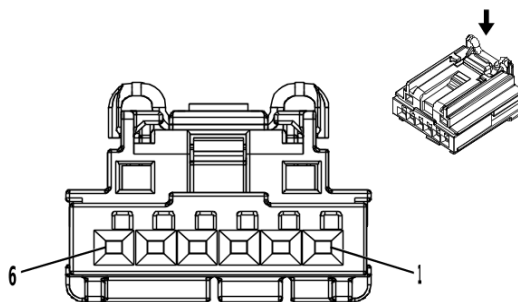

3960313

**Connector Part Information**

Harness Type: Front Floor Console Wiring Harness  
 OEM Connector: 2035363-4  
 Service Connector: Service by Harness - See Part Catalog  
 Description: 6-Way F 0.64 Generation Y Series( BK)

**Terminal Part Information**

Terminal Type ID	Terminated Lead	Diagnostic Test Probe	Terminal Removal Tool
I	Not required	J-35616-64B (L-BU)	No Tool Required

**X83B Audio/Video Receptacle X1 (D07)**

Pin	Size	Color	Circuit	Function	Terminal Type ID	Option
1	0.5	RD / VT	2640	Battery Positive Voltage	I	—
2	0.35	YE	6817	LED Backlight Dimming Control 1	I	—
3	0.5	BK / WH	1051	Signal Ground	I	—
4 - 6	—	—	—	Not Occupied	—	—



**X83B Audio/Video Receptacle X2 (D07)**

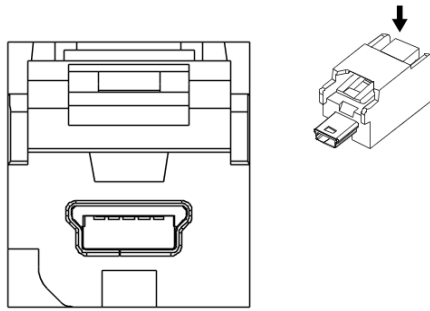

3214018

**Connector Part Information**

Harness Type: Front Floor Console Wiring Harness USB  
 OEM Connector: 13890926  
 Service Connector: Service by Cable Assembly — See Part Catalog  
 Description: 5-Way M 2.0 Mini-B USB Type( GY)

**Terminal Part Information**

Terminal Type ID	Terminated Lead	Diagnostic Test Probe	Terminal Removal Tool
I	Not required	No Tool Required	No Tool Required

**X83B Audio/Video Receptacle X2 (D07)**

Pin	Size	Color	Circuit	Function	Terminal Type ID	Option
—	—	USB	—	USB Serial Data	I	—

**X84 Data Link Connector**

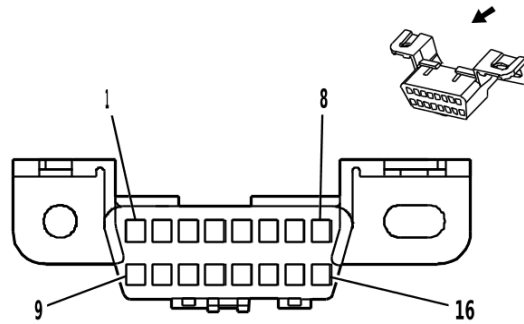

68793

**Connector Part Information**

Harness Type: Instrument Panel Wiring Harness  
 OEM Connector: 12110250  
 Service Connector: 12110250  
 Description: 16-Way F 150 Metri-Pack Series( BK)

**Terminal Part Information**

Terminal Type ID	Terminated Lead	Diagnostic Test Probe	Terminal Removal Tool
I	13580059	J-35616-14 (GN)	J-38125-12A
II	Service by Cable	No Tool Required	No Tool Required

**X84 Data Link Connector**

Pin	Size	Color	Circuit	Function	Terminal Type ID	Option
1	0.35	BU / BN	4983	AUTOSAR CAN Bus [+] 7 Serial Data	I	—
2	0.35	GN	2578	Private Serial Data Presentation CAN Bus [+] 1 Serial Data	I	—
3	0.35	BU	4973	Ethernet Bus 1R [+]	II	—
4	0.5	BK	1050	Ground	I	—
5	0.5	BK / WH	851	Signal Ground	I	—
6	0.35	YE	4981	AUTOSAR CAN Bus [+] 6 Serial Data	I	—
7	0.35	VT	2580	Private Serial Data Presentation CAN Bus [+] 2 Serial Data	I	—
8	0.35	WH	7207	Ethernet Bus 1 Enable Signal	I	—
9	0.35	WH	4982	AUTOSAR CAN Bus [-] 7 Serial Data	I	—
10	0.35	BN	2577	Private Serial Data Presentation CAN Bus [-] 1 Serial Data	I	—
11	0.35	YE	4972	Ethernet Bus 1R [-]	II	—
12	0.35	WH	4975	Ethernet Bus 1T [+]	II	—
13	0.35	GN	4974	Ethernet Bus 1T [-]	II	—
14	0.35	WH	4980	AUTOSAR CAN Bus [-] 6 Serial Data	I	—
15	0.35	GY	2579	Private Serial Data Presentation CAN Bus [-] 2 Serial Data	I	—
16	0.5	RD / YE	6540	Battery Positive Voltage	I	—

## X85 Steering Wheel Airbag Coil X1 (- UKL)

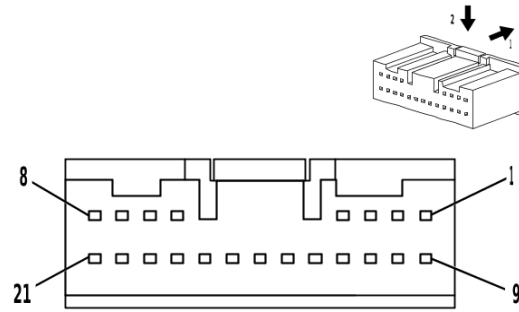

3960237

### Connector Part Information

Harness Type: Instrument Panel Wiring Harness  
 OEM Connector: ATLCPB-21B-2AY  
 Service Connector: 13510218  
 Description: 21-Way F 0.64 Series( YE)

### Terminal Part Information

Terminal Type ID	Terminated Lead	Diagnostic Test Probe	Terminal Removal Tool
I	13575742	J-35616-64B (L-BU)	J-38125-215A
II	13575865	J-35616-64B (L-BU)	J-38125-215A

### X85 Steering Wheel Airbag Coil X1 (- UKL)

Pin	Size	Color	Circuit	Function	Terminal Type ID	Option
1	0.5	BK / WH	851	Signal Ground	I	—
2	0.35	GN / WH	3287	Horn Switch Signal	I	—
3 - 4	—	—	—	Not Occupied	—	—
5	0.5	OG / GN	3023	Steering Wheel Air Bag Stage 2 High Control	II	—
6	0.5	WH / OG	3022	Steering Wheel Air Bag Stage 2 Low Control	II	—
7	0.5	BN / OG	3020	Steering Wheel Air Bag Stage 1 Low Control	II	—
8	0.5	OG / VT	3021	Steering Wheel Air Bag Stage 1 High Control	II	—
9	0.5	GN / BK	3894	Instrument Panel Cluster Control Module LIN Bus 1	I	—
10	0.35	GN / BK	2858	Body Control Module LIN Bus 12	I	—
11	0.35	BN / GN	1884	Cruise Control Set/Coast/Resume/Accelerate Switch Signal	I	—
12	0.35 0.5	BK / VT BK / VT	1449	Steering Wheel Resistor Ladder Low Reference	I	( K34/ KSG/ UEU) - N38- URC URC- N38+ ( K34/ KSG/ UEU)
			1449	Steering Wheel Resistor Ladder Low Reference	I	
13	—	—	—	Not Occupied	—	—
14	0.5	RD / GN	5140	Battery Positive Voltage	I	—
15	0.35	GY / GN	5737	Distance Sensing Cruise Control Gap Up/Down Switch Signal	I	—
16	0.35	VT / YE	5526	Tap Up/Tap Down Switch Signal	I	—
17	0.35	YE	6817	LED Backlight Dimming Control 1	I	—

**6-734 Electrical Component and Inline Harness Connector End Views****X85 Steering Wheel Airbag Coil X1 (- UKL) (cont'd)**

Pin	Size	Color	Circuit	Function	Terminal Type ID	Option
18 - 19	—	—	—	Not Occupied	—	—
20	0.5	BK	1050	Ground	I	—
21	0.5	RD / BN	10040	Battery Positive Voltage	I	—

### X85 Steering Wheel Airbag Coil X1 (UKL)

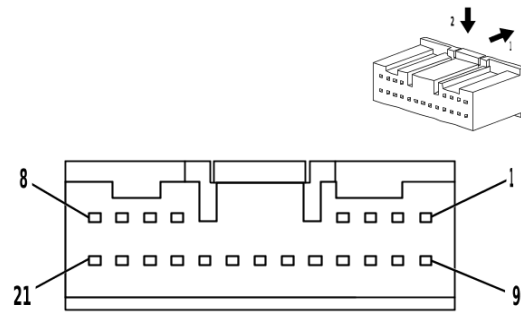

3960237

#### Connector Part Information

Harness Type: Instrument Panel Wiring Harness  
 OEM Connector: ATLCPB-21B-2AY  
 Service Connector: 13510218  
 Description: 21-Way F 0.64 Series( YE)

#### Terminal Part Information

Terminal Type ID	Terminated Lead	Diagnostic Test Probe	Terminal Removal Tool
I	13575742	J-35616-64B (L-BU)	J-38125-215A
II	13575865	J-35616-64B (L-BU)	J-38125-215A

### X85 Steering Wheel Airbag Coil X1 (UKL)

Pin	Size	Color	Circuit	Function	Terminal Type ID	Option
1	0.5	BK / WH	851	Signal Ground	I	—
2	0.35	GN / WH	3287	Horn Switch Signal	I	—
3 - 4	—	—	—	Not Occupied	—	—
5	0.5	OG / GN	3023	Steering Wheel Air Bag Stage 2 High Control	II	—
6	0.5	WH / OG	3022	Steering Wheel Air Bag Stage 2 Low Control	II	—
7	0.5	BN / OG	3020	Steering Wheel Air Bag Stage 1 Low Control	II	—
8	0.5	OG / VT	3021	Steering Wheel Air Bag Stage 1 High Control	II	—
9	0.5	GN / BK	3894	Instrument Panel Cluster Control Module LIN Bus 1	I	—
10	0.5	GN / GY	4627	Image Processing Module LIN Bus 1	I	D07+ UKL
	0.35	GN / BK	2858	Body Control Module LIN Bus 12	I	KI3+ N38- UKL
11	0.35	BN / GN	1884	Cruise Control Set/Coast/Resume/Accelerate Switch Signal	I	—
12	0.5	BK / VT	1449	Steering Wheel Resistor Ladder Low Reference	I	—
13	0.35	WH / VT	2246	Driver Illumination Lamp 1 Control	I	—
14	0.5	RD / GN	5140	Battery Positive Voltage	I	—
15	0.35	GY / GN	5737	Distance Sensing Cruise Control Gap Up/Down Switch Signal	I	—
16	0.35	VT / YE	5526	Tap Up/Tap Down Switch Signal	I	—
17	0.35	YE / BU	2245	Driver Illumination Lamp 2 Control	I	—
18	0.35	BU / BN	7744	Driver Illumination Lamp Ground	I	—
19	—	—	—	Not Occupied	—	—

**6-736 Electrical Component and Inline Harness Connector End Views****X85 Steering Wheel Airbag Coil X1 (UKL) (cont'd)**

Pin	Size	Color	Circuit	Function	Terminal Type ID	Option
20	0.5	BK	1050	Ground	I	—
21	0.5	RD / BN	10040	Battery Positive Voltage	I	—

### X85 Steering Wheel Airbag Coil X2 (N57 - D07)

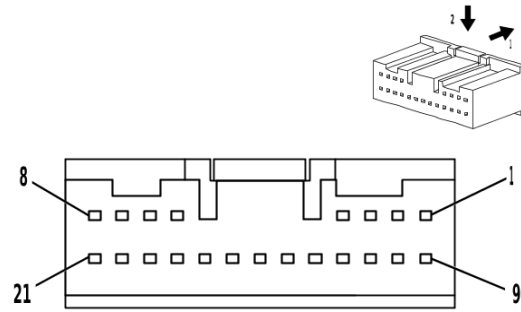

3960237

#### Connector Part Information

Harness Type: Steering Wheel Horn Switch Wiring Harness  
 OEM Connector: 13510218  
 Service Connector: Service by Harness - See Part Catalog  
 Description: 21-Way F 0.64 Series( YE)

#### Terminal Part Information

Terminal Type ID	Terminated Lead	Diagnostic Test Probe	Terminal Removal Tool
I	Not required	J-35616-64B (L-BU)	No Tool Required

#### X85 Steering Wheel Airbag Coil X2 (N57 - D07)

Pin	Size	Color	Circuit	Function	Terminal Type ID	Option
1	0.35	BK	6051	Steering Wheel Ground	I	—
2	0.35	GN / WH	3287	Horn Switch Signal	I	—
3 - 4	—	—	—	Not Occupied	—	—
5	0.5	GY / GN	3023	Steering Wheel Air Bag Stage 2 High Control	I	—
6	0.5	WH / VT	3022	Steering Wheel Air Bag Stage 2 Low Control	I	—
7	0.5	BN / WH	3020	Steering Wheel Air Bag Stage 1 Low Control	I	—
8	0.5	YE / VT	3021	Steering Wheel Air Bag Stage 1 High Control	I	—
9	0.5	OG / BN	10040	Battery Positive Voltage	I	KI3
10	0.5	BK	6050	Steering Wheel Ground	I	KI3
11 - 14	—	—	—	Not Occupied	—	—
15	0.35	GY / GN	5737	Distance Sensing Cruise Control Gap Up/Down Switch Signal	I	—
16	0.35	GN / GN	5140	Battery Positive Voltage	I	—
17	—	—	—	Not Occupied	—	—
18	0.35	BU	1449	Steering Wheel Resistor Ladder Low Reference	I	—
19	0.35	BN / GN	1884	Cruise Control Set/Coast/Resume/Accelerate Switch Signal	I	—
20	0.35	GN / BK	2858	Body Control Module LIN Bus 12	I	KI3
21	0.35	GN / BK	3894	Instrument Panel Cluster Control Module LIN Bus 1	I	—

**X85 Steering Wheel Airbag Coil X2 (NK5 / D07)**

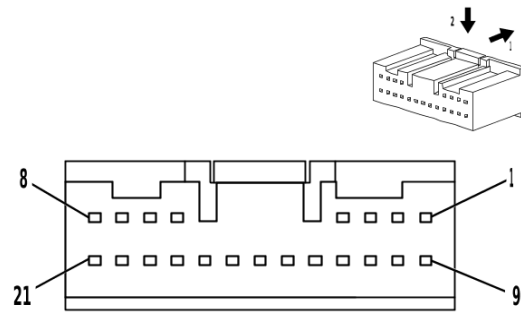

3960237

**Connector Part Information**

Harness Type: Steering Wheel Horn Switch Wiring Harness  
 OEM Connector: 13510218  
 Service Connector: Service by Harness - See Part Catalog  
 Description: 21-Way F 0.64 Series( YE)

**Terminal Part Information**

Terminal Type ID	Terminated Lead	Diagnostic Test Probe	Terminal Removal Tool
I	Not required	J-35616-64B (L-BU)	No Tool Required

**X85 Steering Wheel Airbag Coil X2 (NK5 / D07)**

Pin	Size	Color	Circuit	Function	Terminal Type ID	Option
1	0.35	BK / WH	6051	Steering Wheel Ground	I	—
2	0.35	GN / WH	3287	Horn Switch Signal	I	—
3 - 4	—	—	—	Not Occupied	—	—
5	0.5	OG / GN	3023	Steering Wheel Air Bag Stage 2 High Control	I	—
6	0.5	WH / OG	3022	Steering Wheel Air Bag Stage 2 Low Control	I	—
7	0.5	BN / OG	3020	Steering Wheel Air Bag Stage 1 Low Control	I	—
8	0.5	OG / VT	3021	Steering Wheel Air Bag Stage 1 High Control	I	—
9	0.5	RD / GN	10040	Battery Positive Voltage	I	KI3
10	0.5	BK	6050	Steering Wheel Ground	I	KI3
11 - 12	—	—	—	Not Occupied	—	—
13	0.35	PK	3893	Steering Wheel LED Backlight Dimming Control	I	NK5
14	0.35	VT / YE	5526	Tap Up/Tap Down Switch Signal	I	—
15	0.35	GY / GN	5737	Distance Sensing Cruise Control Gap Up/Down Switch Signal	I	—
16	0.35	RD / GN	5140	Battery Positive Voltage	I	—
17	—	—	—	Not Occupied	—	—
18	0.35	BK / VT	1449	Steering Wheel Resistor Ladder Low Reference	I	—
19	0.35	BN / GN	1884	Cruise Control Set/Coast/Resume/Accelerate Switch Signal	I	—
20	0.35	GN / BK	2858	Body Control Module LIN Bus 12	I	KI3
21	0.35	GN / BK	3894	Instrument Panel Cluster Control Module LIN Bus 1	I	—



### X88B Tow Vehicle Electrical Receptacle X1

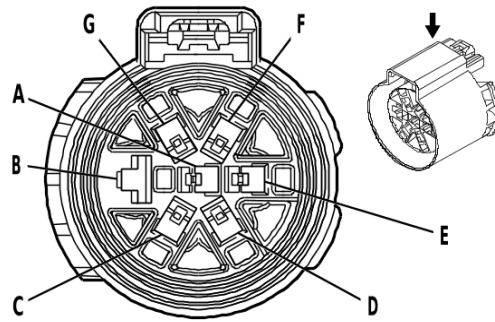

2056936

#### Connector Part Information

Harness Type: Chassis Wiring Harness  
 OEM Connector: 13857223  
 Service Connector: 86816072  
 Description: 7-Way F 280, 630 Metri-Pack Series, Sealed( BK)

#### Terminal Part Information

Terminal Type ID	Terminated Lead	Diagnostic Test Probe	Terminal Removal Tool
I	Not required	J-35616-42 (RD)	No Tool Required
II	Not required	J-35616-4A (PU)	No Tool Required

#### X88B Tow Vehicle Electrical Receptacle X1

Pin	Size	Color	Circuit	Function	Terminal Type ID	Option
A	1	GY	1624	Trailer Backup Lamp Control	II	UET
	1	GY	5189	Trailer Backup Lamp Control	II	- UET
B	5	WH	22	Trailer Ground	I	—
C	2.5	BU	47	Trailer Auxiliary Control	II	—
D	1	GN	1619	Right Rear Trailer Stop/Turn Lamp Control	II	—
E	4	OG	3940	Battery Positive Voltage	II	—
	1	BN	2109	Trailer Park Lamp Control	II	UET
F	1.5	BN	2109	Trailer Park Lamp Control	II	- UET
	1	YE	1618	Left Rear Trailer Stop/Turn Lamp Control	II	—

**X88B Tow Vehicle Electrical Receptacle X2**

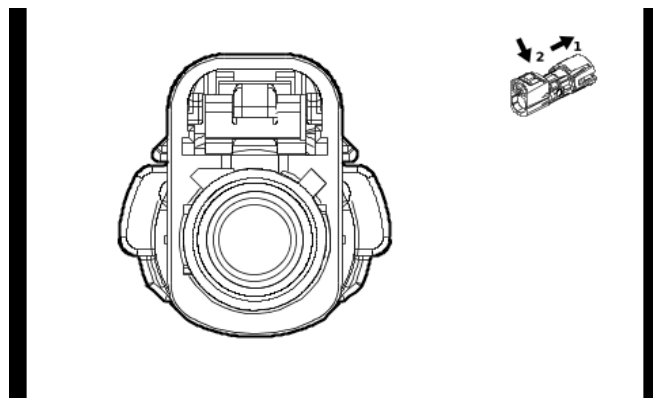

5758030

**Connector Part Information**

Harness Type: Chassis Wiring Harness COAX  
 OEM Connector: 35187032  
 Service Connector: Service by Cable Assembly — See Part Catalog  
 Description: 1-Way F Coax Type( BK)

**Terminal Part Information**

Terminal Type ID	Terminated Lead	Diagnostic Test Probe	Terminal Removal Tool
I	Not required	No Tool Required	No Tool Required

**X88B Tow Vehicle Electrical Receptacle X2**

Pin	Size	Color	Circuit	Function	Terminal Type ID	Option
—	—	Coax Cable	—	Trailer Rear Vision Camera Coaxial Video Signal	I	—

**X88B Tow Vehicle Electrical Receptacle X3**

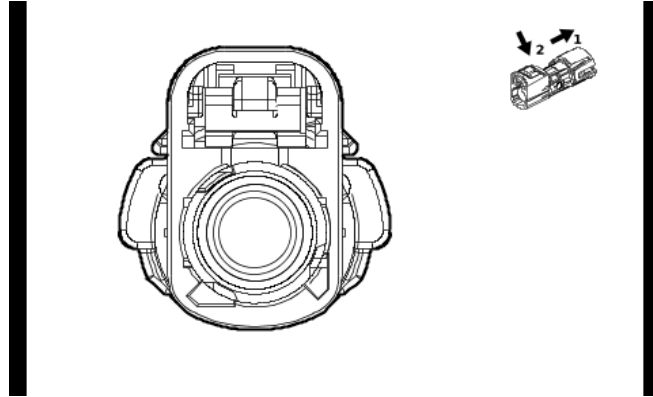

5757455

**Connector Part Information**

Harness Type: Chassis Wiring Harness COAX  
 OEM Connector: 35187043  
 Service Connector: Service by Cable Assembly — See Part Catalog  
 Description: 1-Way F Coax Type( OG)

**Terminal Part Information**

Terminal Type ID	Terminated Lead	Diagnostic Test Probe	Terminal Removal Tool
I	Not required	No Tool Required	No Tool Required

**X88B Tow Vehicle Electrical Receptacle X3**

Pin	Size	Color	Circuit	Function	Terminal Type ID	Option
—	—	Coax Cable	—	Trailer 2 Rear Vision Camera Coaxial Video Signal	I	—

**X92CD Dual Charge Only Receptacle - Floor Console Rear (UBI)**

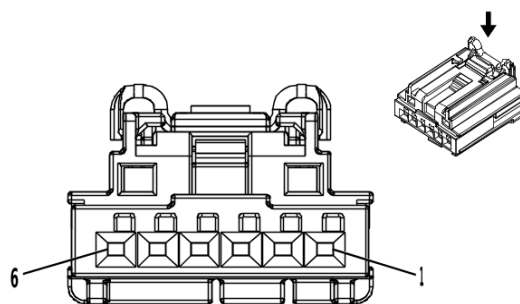

3960313

**Connector Part Information**

Harness Type: Front Floor Console Wiring Harness  
 OEM Connector: 2035363-4  
 Service Connector: Service by Harness - See Part Catalog  
 Description: 6-Way F 0.64 Generation Y Series( BK)

**Terminal Part Information**

Terminal Type ID	Terminated Lead	Diagnostic Test Probe	Terminal Removal Tool
I	Not required	J-35616-64B (L-BU)	No Tool Required

**X92CD Dual Charge Only Receptacle - Floor Console Rear (UBI)**

Pin	Size	Color	Circuit	Function	Terminal Type ID	Option
1	0.35	VT	4701	Retained Accessory Power Control	I	—
2	0.35	YE	6817	LED Backlight Dimming Control 1	I	—
3	0.35	BK	1350	Ground	I	—
4 - 6	—	—	—	Not Occupied	—	—

**X92FSR Dual Charge Only Receptacle - Front Center Seat Rear Cover**

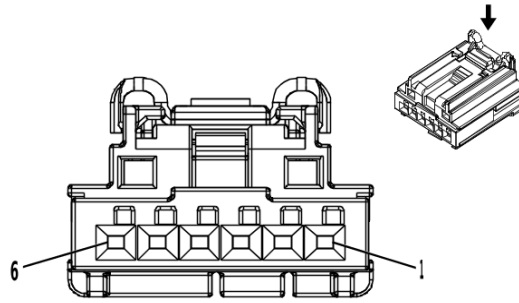

3960313

**Connector Part Information**

Harness Type: Front Seat Wiring Harness - Center  
 OEM Connector: 2035363-4  
 Service Connector: Service by Harness - See Part Catalog  
 Description: 6-Way F 0.64 Generation Y Series( BK)

**Terminal Part Information**

Terminal Type ID	Terminated Lead	Diagnostic Test Probe	Terminal Removal Tool
I	Not required	J-35616-64B (L-BU)	No Tool Required

**X92FSR Dual Charge Only Receptacle - Front Center Seat Rear Cover**

Pin	Size	Color	Circuit	Function	Terminal Type ID	Option
1	0.35	VT	4701	Retained Accessory Power Control	I	—
2	0.35	YE	6817	LED Backlight Dimming Control 1	I	—
3	0.35	BK	1350	Ground	I	—
4 - 6	—	—	—	Not Occupied	—	—

**X92IP USB 2 Port Receptacle - Instrument Panel X1 (- D07)**

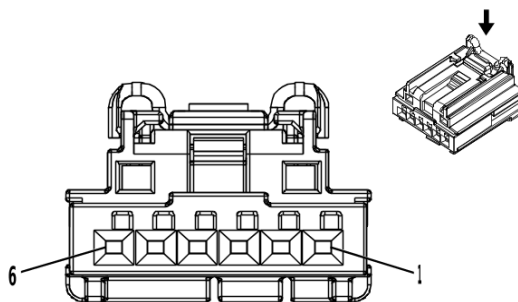

3960313

**Connector Part Information**

Harness Type: Instrument Panel Wiring Harness  
 OEM Connector: 2035363-4  
 Service Connector: 19332786  
 Description: 6-Way F 0.64 Generation Y Series( BK)

**Terminal Part Information**

Terminal Type ID	Terminated Lead	Diagnostic Test Probe	Terminal Removal Tool
I	Not required	J-35616-64B (L-BU)	No Tool Required

**X92IP USB 2 Port Receptacle - Instrument Panel X1 (- D07)**

Pin	Size	Color	Circuit	Function	Terminal Type ID	Option
1	0.5	RD / VT	2640	Battery Positive Voltage	I	—
2	0.5	YE	6817	LED Backlight Dimming Control 1	I	—
3	0.75	BK / WH	1051	Signal Ground	I	—
4 - 6	—	—	—	Not Occupied	—	—

**X92IP USB 2 Port Receptacle - Instrument Panel X2 (- D07)**

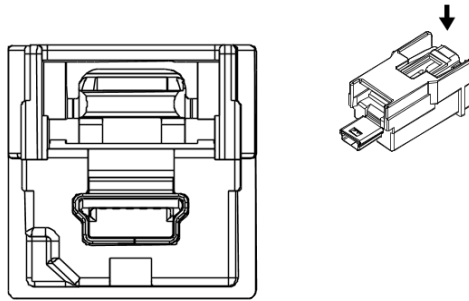

2807491

**Connector Part Information**

Harness Type: Instrument Panel Wiring Harness USB  
 OEM Connector: 111014-9001  
 Service Connector: Service by Cable Assembly — See Part Catalog  
 Description: 5-Way M 2.0 Mini-B USB Type( GY)

**Terminal Part Information**

Terminal Type ID	Terminated Lead	Diagnostic Test Probe	Terminal Removal Tool
I	Not required	No Tool Required	No Tool Required

**X92IP USB 2 Port Receptacle - Instrument Panel X2 (- D07)**

Pin	Size	Color	Circuit	Function	Terminal Type ID	Option
—	—	USB	—	USB Serial Data	I	—

**X92IP USB 2 Port Receptacle - Instrument Panel X3 (- D07)**

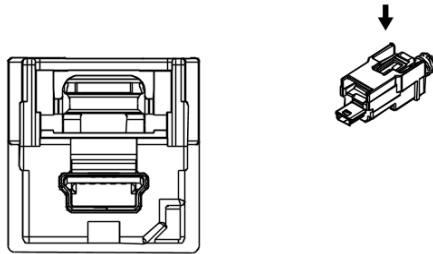

2807425

**Connector Part Information**

Harness Type: Instrument Panel Wiring Harness USB  
 OEM Connector: 13576672  
 Service Connector: Service by Cable Assembly — See Part Catalog  
 Description: 5-Way M 2.0 Mini-B USB Type( BK)

**Terminal Part Information**

Terminal Type ID	Terminated Lead	Diagnostic Test Probe	Terminal Removal Tool
I	Not required	No Tool Required	No Tool Required

**X92IP USB 2 Port Receptacle - Instrument Panel X3 (- D07)**

Pin	Size	Color	Circuit	Function	Terminal Type ID	Option
—	—	USB	—	USB Serial Data	I	—



### Inline Harness Connector End Views

#### X122 Front View Camera Switch Wiring Harness to Body Wiring Harness

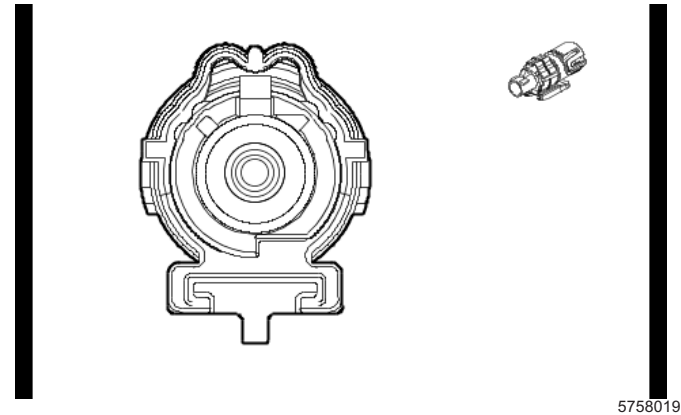
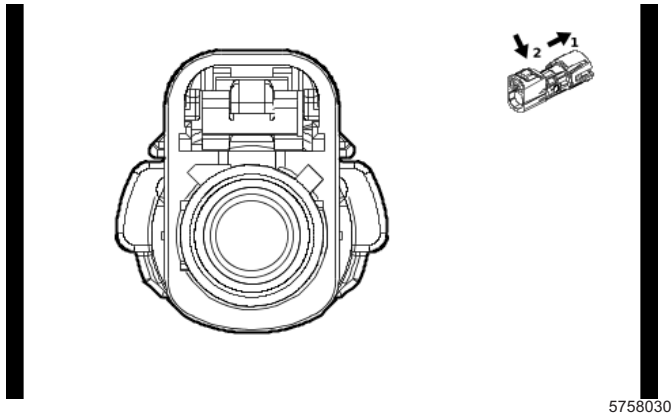

#### Connector Part Information

Harness Type: Front View Camera Switch Wiring Harness COAX  
 OEM Connector: 35187032  
 Service Connector: Service by Cable Assembly — See Part Catalog  
 Description: 1-Way F Coax Type( BK)

#### Connector Part Information

Harness Type: Body Wiring Harness COAX  
 OEM Connector: 33338239  
 Service Connector: Service by Cable Assembly — See Part Catalog  
 Description: 1-Way M Coax Type, Sealed( BK)

#### Terminal Part Information

Terminal Type ID	Terminated Lead	Diagnostic Test Probe	Terminal Removal Tool
I	Not required	No Tool Required	No Tool Required

#### X122 Front View Camera Switch Wiring Harness to Body Wiring Harness

Pin	Size	Color	Circuit	Terminal Type ID	Option	Function	Pin	Size	Color	Circuit	Terminal Type ID	Option
—	—	Coax Cable	—	I	—	Front Vision Camera 1 Coaxial Video Signal	—	—	Coax Cable	—	I	—

**X124 Front View Camera Switch Wiring Harness to Body Wiring Harness**

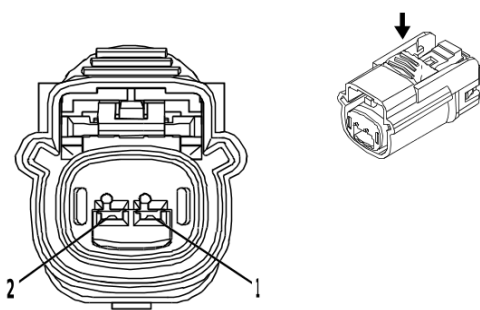

4332222

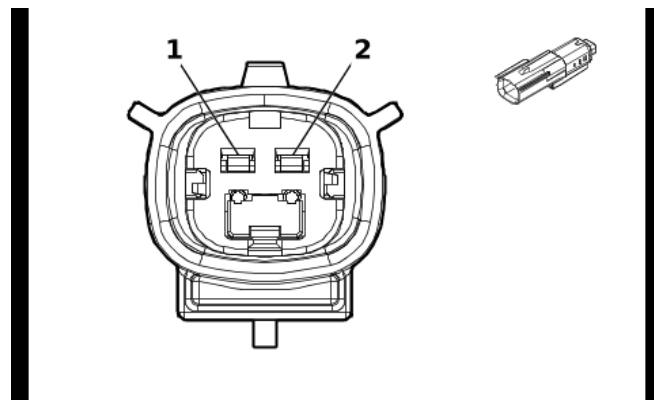

5921817

**Connector Part Information**

Harness Type: Front View Camera Switch Wiring Harness  
 OEM Connector: 15514573  
 Service Connector: Service by Harness - See Part Catalog  
 Description: 2-Way F 1.5 OCS Series, Sealed( BK)

**Connector Part Information**

Harness Type: Body Wiring Harness  
 OEM Connector: 15514550  
 Service Connector: 86825463  
 Description: 2-Way M 1.5 OCS Series, Sealed( BK)

**Terminal Part Information**

Terminal Type ID	Terminated Lead	Diagnostic Test Probe	Terminal Removal Tool
I	Not required	J-35616-14 (GN)	No Tool Required
II	Not required	J-35616-3 (GY)	No Tool Required

**X124 Front View Camera Switch Wiring Harness to Body Wiring Harness**

Pin	Size	Color	Circuit	Terminal Type ID	Option	Function	Pin	Size	Color	Circuit	Terminal Type ID	Option
1	1.5	BN / GN	4246	I	—	Identification Lamp Control	1	1.5	BN / GN	4246	II	—
2	1.5	BK	650	I	—	Ground	2	1	BK	650	II	—

**X125 Engine Wiring Harness to Body Wiring Harness (L3B)**

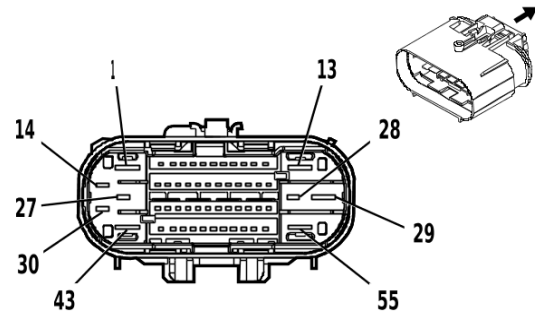
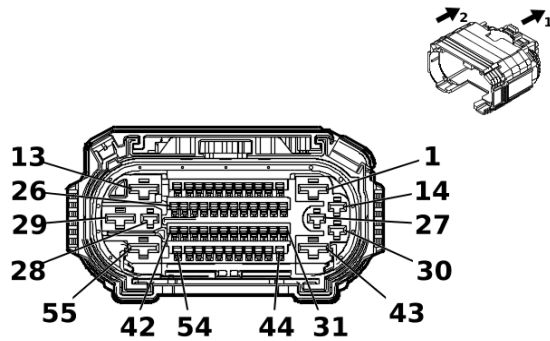

5246872

4994369

**Connector Part Information**

Harness Type: Engine Wiring Harness  
 OEM Connector: 35580811  
 Service Connector: 19371184  
 Description: 55-Way F 1.2 OCS, 2.8, 6.3 CTS Series, Sealed( GY)

**Connector Part Information**

Harness Type: Body Wiring Harness  
 OEM Connector: 35588062  
 Service Connector: 84727363  
 Description: 55-Way M 1.2 OCS, 2.8, 6.3 CTS Series, Sealed( GY)

**Terminal Part Information**

Terminal Type ID	Terminated Lead	Diagnostic Test Probe	Terminal Removal Tool
I	19332901	J-35616-35 (VT)	J-38125-212
II	19370818	J-35616-12 (BU)	J-38125-215A
III	19371217	J-35616-12 (BU)	J-38125-553
IV	84634921	J-35616-42 (RD)	J-38125-212
V	84847992	J-35616-32 (OG)	J-38125-36
VI	84867140	J-35616-13 (BU)	J-38125-215A
VII	84867141	J-35616-13 (BU)	J-38125-215A
VIII	84992391	J-35616-5 (PU)	J-38125-215A

**X125 Engine Wiring Harness to Body Wiring Harness (L3B)**

Pin	Size	Color	Circuit	Terminal Type ID	Option	Function	Pin	Size	Color	Circuit	Terminal Type ID	Option
1	3	BK / WH	251	IV	—	Signal Ground	1	3	BK / WH	251	V	—
2	1.5	RD / GN	1840	III	—	Battery Positive Voltage	2	1.5	RD / GN	1840	VII	—
3	—	—	—	—	—	Not Occupied	3	—	—	—	—	—
4	0.5	BU / GY	4054	II	—	Private Serial Data Powertrain CAN Bus [-] Serial Data	4	0.5	BU / GY	4054	VI	—
5	0.5	WH	4055	II	—	Private Serial Data Powertrain CAN Bus [+] Serial Data	5	0.5	WH	4055	VI	—
6	0.5	WH	4976	II	—	AUTOSAR CAN Bus [-] 3 Serial Data	6	0.5	WH	4976	VI	—

**6-750 Electrical Component and Inline Harness Connector End Views**

**X125 Engine Wiring Harness to Body Wiring Harness (L3B) (cont'd)**

Pin	Size	Color	Circuit	Terminal Type ID	Option	Function	Pin	Size	Color	Circuit	Terminal Type ID	Option
7	0.5	BU / BK	4977	II	—	AUTOSAR CAN Bus [+] 3 Serial Data	7	0.5	BU / BK	4977	VI	—
8	0.5	WH / RD	1164	II	—	Accelerator Pedal Position 5V Reference 1	8	0.35	WH / RD	1164	VI	—
9	0.5	BK / BU	1271	II	—	Accelerator Pedal Position Low Reference 1	9	0.35	BK / BU	1271	VI	—
10	0.5	YE / WH	1161	II	—	Accelerator Pedal Position Signal 1	10	0.35	YE / WH	1161	VI	—
11	0.5	GN / WH	1162	II	—	Accelerator Pedal Position Signal 2	11	0.35	GN / WH	1162	VI	—
12 - 14	—	—	—	—	—	Not Occupied	12 - 14	—	—	—	—	—
15	0.5	BN / RD	1274	II	—	Accelerator Pedal Position 5V Reference 2	15	0.35	BN / RD	1274	VI	—
16	0.5	YE	4063	II	—	Hood Status A Signal	16	0.5	YE	4063	VI	—
17	0.5	VT / GN	4320	II	—	Powertrain Sensor Bus Enable	17	0.5	VT / GN	4320	VI	—
18	0.5	WH / RD	480	II	—	Engine Control Vehicle Sensors 5 Volt Reference 1	18	0.35	WH / RD	480	VI	—
19	—	—	—	—	—	Not Occupied	19	—	—	—	—	—
20	0.5	WH / GN	5380	II	—	Brake Position Sensor Signal	20	0.35	WH / GN	5380	VI	—
21	—	—	—	—	—	Not Occupied	21	—	—	—	—	—
22	0.5	BK / VT	1272	II	—	Accelerator Pedal Position Low Reference 2	22	0.35	BK / VT	1272	VI	—
23	0.5	BK / GY	626	II	—	Engine Control Vehicle Sensors Low Reference 1	23	0.5	BK / GY	626	VI	—
24	0.5	WH / BU	6311	II	—	Cruise/ETC/TCC Brake Signal	24	0.5	WH / BU	6311	VI	—
25	0.5	BU / GY	636	II	—	Ambient Air Temperature Sensor Signal	25	0.5	BU / GY	636	VI	—

**X125 Engine Wiring Harness to Body Wiring Harness (L3B) (cont'd)**

Pin	Size	Color	Circuit	Terminal Type ID	Option	Function	Pin	Size	Color	Circuit	Terminal Type ID	Option
26	0.75	BU / BN	7573	II	—	Air Conditioning Compressor Solenoid Valve Control	26	0.5	BU / BN	7573	VI	—
27	0.75	BU / YE	7574	I	—	Air Conditioning Compressor Solenoid Valve Control	27	0.5	BU / YE	7574	VIII	—
28 - 30	—	—	—	—	—	Not Occupied	28 - 30	—	—	—	—	—
31	0.5	WH	4978	II	—	AUTOSAR CAN Bus [-] 2 Serial Data	31	0.5	WH	4978	VI	—
32	0.5	BU / YE	4979	II	—	AUTOSAR CAN Bus [+] 2 Serial Data	32	0.5	BU / YE	4979	VI	—
33	0.5	YE / BK	625	II	—	Starter Enable Relay Control	33	0.5	YE / BK	625	VI	—
34 - 36	—	—	—	—	—	Not Occupied	34 - 36	—	—	—	—	—
37	0.5	GN / GY	465	II	—	Fuel Pump Primary Relay Control	37	0.5	GN / GY	465	VI	—
38 - 55	—	—	—	—	—	Not Occupied	38 - 55	—	—	—	—	—

X125 Engine Wiring Harness to Body Wiring Harness (L84 / L87)

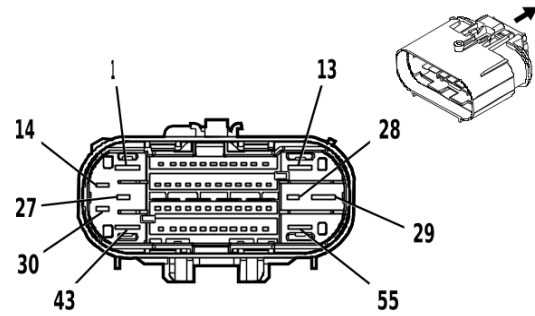
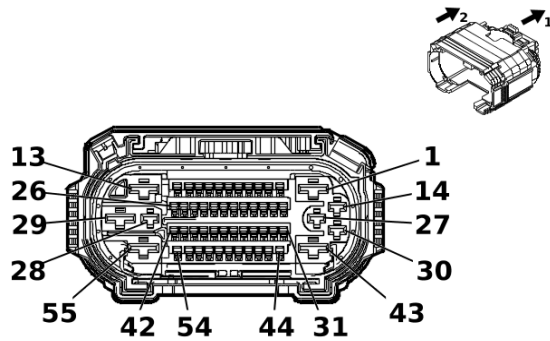

5246872

4994369

**Connector Part Information**

Harness Type: Engine Wiring Harness  
 OEM Connector: 35580811  
 Service Connector: 19371184  
 Description: 55-Way F 1.2 OCS, 2.8, 6.3 CTS Series, Sealed( GY)

**Connector Part Information**

Harness Type: Body Wiring Harness  
 OEM Connector: 35588062  
 Service Connector: 84727363  
 Description: 55-Way M 1.2 OCS, 2.8, 6.3 CTS Series, Sealed( GY)

**Terminal Part Information**

Terminal Type ID	Terminated Lead	Diagnostic Test Probe	Terminal Removal Tool
I	19332901	J-35616-35 (VT)	J-38125-212
II	19370818	J-35616-12 (BU)	J-38125-215A
III	19371217	J-35616-12 (BU)	J-38125-553
IV	84634921	J-35616-42 (RD)	J-38125-212
V	84847992	J-35616-32 (OG)	J-38125-36
VI	84867140	J-35616-13 (BU)	J-38125-215A
VII	84867141	J-35616-13 (BU)	J-38125-215A
VIII	84992391	J-35616-5 (PU)	J-38125-215A

**X125 Engine Wiring Harness to Body Wiring Harness (L84 / L87)**

Pin	Size	Color	Circuit	Terminal Type ID	Option	Function	Pin	Size	Color	Circuit	Terminal Type ID	Option
1	3	BK / WH	251	IV	—	Signal Ground	1	3	BK / WH	251	V	—
2	1.5	RD / GN	1840	III	—	Battery Positive Voltage	2	1.5	RD / GN	1840	VII	—
3	—	—	—	—	—	Not Occupied	3	—	—	—	—	—
4	0.5	BU / GY	4054	II	—	Private Serial Data Powertrain CAN Bus [-] Serial Data	4	0.5	BU / GY	4054	VI	—
5	0.5	WH	4055	II	—	Private Serial Data Powertrain CAN Bus [+] Serial Data	5	0.5	WH	4055	VI	—
6	0.5	WH	4976	II	—	AUTOSAR CAN Bus [-] 3 Serial Data	6	0.5	WH	4976	VI	—

**X125 Engine Wiring Harness to Body Wiring Harness (L84 / L87) (cont'd)**

Pin	Size	Color	Circuit	Terminal Type ID	Option	Function	Pin	Size	Color	Circuit	Terminal Type ID	Option
7	0.5	BU / BK	4977	II	—	AUTOSAR CAN Bus [+] 3 Serial Data	7	0.5	BU / BK	4977	VI	—
8	0.5	WH / RD	1164	II	—	Accelerator Pedal Position 5V Reference 1	8	0.35	WH / RD	1164	VI	—
9	0.5	BK / BU	1271	II	—	Accelerator Pedal Position Low Reference 1	9	0.35	BK / BU	1271	VI	—
10	0.5	YE / WH	1161	II	—	Accelerator Pedal Position Signal 1	10	0.35	YE / WH	1161	VI	—
11	0.5	GN / WH	1162	II	—	Accelerator Pedal Position Signal 2	11	0.35	GN / WH	1162	VI	—
12 - 14	—	—	—	—	—	Not Occupied	12 - 14	—	—	—	—	—
15	0.5	BN / RD	1274	II	—	Accelerator Pedal Position 5V Reference 2	15	0.35	BN / RD	1274	VI	—
16	0.5	YE	4063	II	—	Hood Status A Signal	16	0.5	YE	4063	VI	—
17	0.5	VT / GN	4320	II	—	Powertrain Sensor Bus Enable	17	0.5	VT / GN	4320	VI	—
18	0.5	WH / RD	480	II	—	Engine Control Vehicle Sensors 5 Volt Reference 1	18	0.35	WH / RD	480	VI	—
19	—	—	—	—	—	Wait To Start Indicator Control	19	0.35	GN / BN	507	VI	—
20	0.5	WH / GN	5380	II	—	Brake Position Sensor Signal	20	0.35	WH / GN	5380	VI	—
21	—	—	—	—	—	Not Occupied	21	—	—	—	—	—
22	0.5	BK / VT	1272	II	—	Accelerator Pedal Position Low Reference 2	22	0.35	BK / VT	1272	VI	—
23	0.5	BK / GY	626	II	—	Engine Control Vehicle Sensors Low Reference 1	23	0.5	BK / GY	626	VI	—
24	0.5	WH / BU	6311	II	—	Cruise/ETC/TCC Brake Signal	24	0.5	WH / BU	6311	VI	—
25	0.5	BU / GY	636	II	—	Ambient Air Temperature Sensor Signal	25	0.5	BU / GY	636	VI	—

**6-754 Electrical Component and Inline Harness Connector End Views**

**X125 Engine Wiring Harness to Body Wiring Harness (L84 / L87) (cont'd)**

Pin	Size	Color	Circuit	Terminal Type ID	Option	Function	Pin	Size	Color	Circuit	Terminal Type ID	Option
26	0.75	BU / BN	7573	II	—	Air Conditioning Compressor Solenoid Valve Control	26	0.5	BU / BN	7573	VI	—
27	0.75	BU / YE	7574	I	—	Air Conditioning Compressor Solenoid Valve Control	27	0.5	BU / YE	7574	VIII	—
28	—	—	—	—	—	Powertrain Sensor Bus Enable	28	0.5	VT / GN	4320	VIII	—
29 - 30	—	—	—	—	—	Not Occupied	29 - 30	—	—	—	—	—
31	0.5	WH	4978	II	—	AUTOSAR CAN Bus [-] 2 Serial Data	31	0.5	WH	4978	VI	—
32	0.5	BU / YE	4979	II	—	AUTOSAR CAN Bus [+] 2 Serial Data	32	0.5	BU / YE	4979	VI	—
33	0.5	YE / BK	625	II	—	Starter Enable Relay Control	33	0.5	YE / BK	625	VI	—
34 - 36	—	—	—	—	—	Not Occupied	34 - 36	—	—	—	—	—
37	0.5	GN / GY	465	II	—	Fuel Pump Primary Relay Control	37	0.5	GN / GY	465	VI	—
38	—	—	—	—	—	Not Occupied	38	—	—	—	—	—
39	0.5	BU / WH	4306	II	—	Exhaust Flow Control Valve 1 - Cylinder Deactivation Feedback Signal	39	—	—	—	—	—
40	0.5	BN / GN	4305	II	—	Exhaust Flow Control Valve 1	40	—	—	—	—	—
41 - 55	—	—	—	—	—	Not Occupied	41 - 55	—	—	—	—	—



**X125 Engine Wiring Harness to Body Wiring Harness (LZ0)**

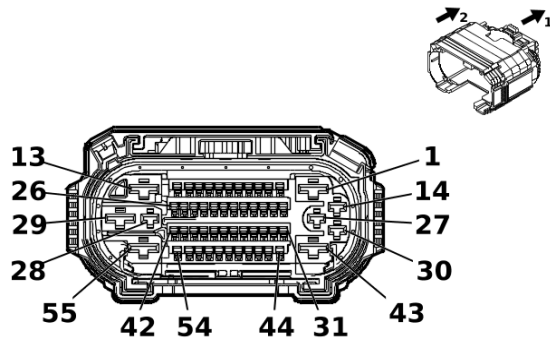

5246872

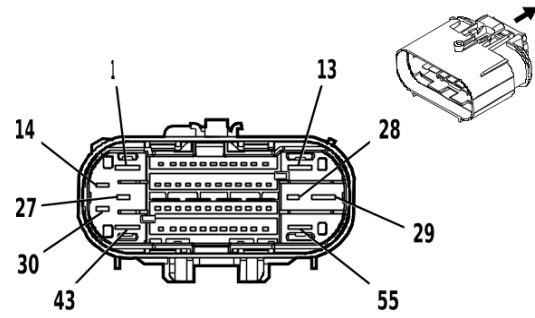

4994369

**Connector Part Information**

Harness Type: Engine Wiring Harness  
 OEM Connector: 35580811  
 Service Connector: 19371184  
 Description: 55-Way F 1.2 OCS, 2.8, 6.3 CTS Series, Sealed( GY)

**Connector Part Information**

Harness Type: Body Wiring Harness  
 OEM Connector: 35588062  
 Service Connector: 84727363  
 Description: 55-Way M 1.2 OCS, 2.8, 6.3 CTS Series, Sealed( GY)

**Terminal Part Information**

Terminal Type ID	Terminated Lead	Diagnostic Test Probe	Terminal Removal Tool
I	19332901	J-35616-35 (VT)	J-38125-212
II	19370818	J-35616-12 (BU)	J-38125-215A
III	19371217	J-35616-12 (BU)	J-38125-553
IV	84634921	J-35616-42 (RD)	J-38125-212
V	84847992	J-35616-32 (OG)	J-38125-36
VI	84867140	J-35616-13 (BU)	J-38125-215A
VII	84867141	J-35616-13 (BU)	J-38125-215A
VIII	84992391	J-35616-5 (PU)	J-38125-215A

**X125 Engine Wiring Harness to Body Wiring Harness (LZ0)**

Pin	Size	Color	Circuit	Terminal Type ID	Option	Function	Pin	Size	Color	Circuit	Terminal Type ID	Option
1	3	BK / WH	251	IV	—	Signal Ground	1	3	BK / WH	251	V	—
2	1.5	RD / GN	1840	III	—	Battery Positive Voltage	2	1.5	RD / GN	1840	VII	—
3	—	—	—	—	—	Not Occupied	3	—	—	—	—	—
4	0.5	BU / GY	4054	II	—	Private Serial Data Powertrain CAN Bus [-] Serial Data	4	0.5	BU / GY	4054	VI	—
5	0.5	WH	4055	II	—	Private Serial Data Powertrain CAN Bus [+] Serial Data	5	0.5	WH	4055	VI	—
6	0.5	WH	4976	II	—	AUTOSAR CAN Bus [-] 3 Serial Data	6	0.5	WH	4976	VI	—

**6-756 Electrical Component and Inline Harness Connector End Views**
**X125 Engine Wiring Harness to Body Wiring Harness (LZ0) (cont'd)**

Pin	Size	Color	Circuit	Terminal Type ID	Option	Function	Pin	Size	Color	Circuit	Terminal Type ID	Option
7	0.5	BU / BK	4977	II	—	AUTOSAR CAN Bus [+] 3 Serial Data	7	0.5	BU / BK	4977	VI	—
8	0.5	WH / RD	1164	II	—	Accelerator Pedal Position 5V Reference 1	8	0.35	WH / RD	1164	VI	—
9	0.5	BK / BU	1271	II	—	Accelerator Pedal Position Low Reference 1	9	0.35	BK / BU	1271	VI	—
10	0.5	YE / WH	1161	II	—	Accelerator Pedal Position Signal 1	10	0.35	YE / WH	1161	VI	—
11	0.5	GN / WH	1162	II	—	Accelerator Pedal Position Signal 2	11	0.35	GN / WH	1162	VI	—
12 - 14	—	—	—	—	—	Not Occupied	12 - 14	—	—	—	—	—
15	0.5	BN / RD	1274	II	—	Accelerator Pedal Position 5V Reference 2	15	0.35	BN / RD	1274	VI	—
16	0.5	YE	4063	II	—	Hood Status A Signal	16	0.5	YE	4063	VI	—
17	—	—	—	—	—	Powertrain Sensor Bus Enable	17	0.5	VT / GN	4320	VI	—
18	0.5	WH / RD	480	II	—	Engine Control Vehicle Sensors 5 Volt Reference 1	18	0.35	WH / RD	480	VI	—
19	0.5	GN / BN	507	II	—	Wait To Start Indicator Control	19	0.35	GN / BN	507	VI	—
20	0.5	WH / GN	5380	II	—	Brake Position Sensor Signal	20	0.35	WH / GN	5380	VI	—
21	—	—	—	—	—	Not Occupied	21	—	—	—	—	—
22	0.5	BK / VT	1272	II	—	Accelerator Pedal Position Low Reference 2	22	0.35	BK / VT	1272	VI	—
23	0.5	BK / GY	626	II	—	Engine Control Vehicle Sensors Low Reference 1	23	0.5	BK / GY	626	VI	—
24	0.5	WH / BU	6311	II	—	Cruise/ETC/TCC Brake Signal	24	0.5	WH / BU	6311	VI	—
25	0.5	BU / GY	636	II	—	Ambient Air Temperature Sensor Signal	25	0.5	BU / GY	636	VI	—

**X125 Engine Wiring Harness to Body Wiring Harness (LZ0) (cont'd)**

Pin	Size	Color	Circuit	Terminal Type ID	Option	Function	Pin	Size	Color	Circuit	Terminal Type ID	Option
26	0.75	BU / BN	7573	II	—	Air Conditioning Compressor Solenoid Valve Control	26	0.5	BU / BN	7573	VI	—
27	0.75	BU / YE	7574	I	—	Air Conditioning Compressor Solenoid Valve Control	27	0.5	BU / YE	7574	VIII	—
28	0.5	VT / GN	4320	I	—	Powertrain Sensor Bus Enable	28	0.5	VT / GN	4320	VIII	—
29 - 30	—	—	—	—	—	Not Occupied	29 - 30	—	—	—	—	—
31	0.5	WH	4978	II	—	AUTOSAR CAN Bus [-] 2 Serial Data	31	0.5	WH	4978	VI	—
32	0.5	BU / YE	4979	II	—	AUTOSAR CAN Bus [+] 2 Serial Data	32	0.5	BU / YE	4979	VI	—
33	0.5	YE / BK	625	II	—	Starter Enable Relay Control	33	0.5	YE / BK	625	VI	—
34 - 36	—	—	—	—	—	Not Occupied	34 - 36	—	—	—	—	—
37	—	—	—	—	—	Fuel Pump Primary Relay Control	37	0.5	GN / GY	465	VI	—
38 - 55	—	—	—	—	—	Not Occupied	38 - 55	—	—	—	—	—

**X128 Engine Wiring Harness to Camshaft Position Sensor Wire**

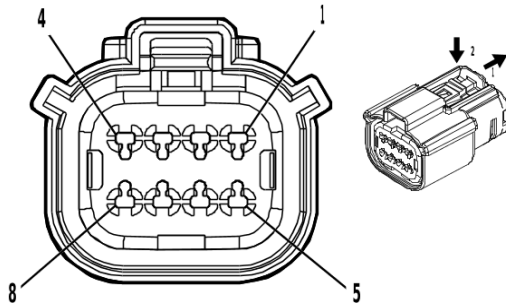

4846407

**Connector Part Information**

Harness Type: Engine Wiring Harness  
 OEM Connector: 33472-4877  
 Service Connector: 84928314  
 Description: 8-Way F 1.5 MX Series, Sealed( BK)

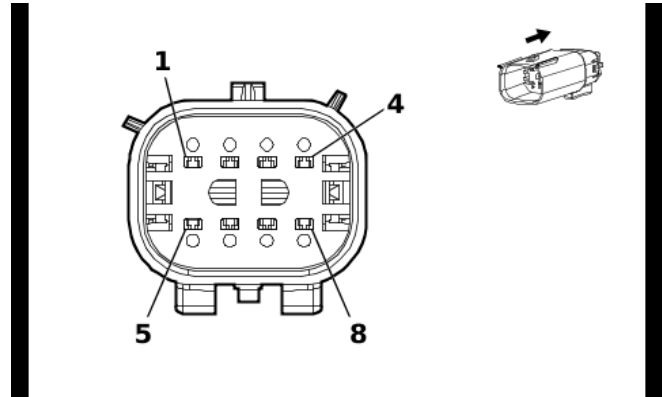

5429080

**Connector Part Information**

Harness Type: Camshaft Position Sensor Wire  
 OEM Connector: Not Available  
 Service Connector: Service by Harness - See Part Catalog  
 Description: 8-Way M ( BK)

**Terminal Part Information**

Terminal Type ID	Terminated Lead	Diagnostic Test Probe	Terminal Removal Tool
I	Not required	J-35616-14 (GN)	No Tool Required
II	Not required	No Tool Required	No Tool Required

**X128 Engine Wiring Harness to Camshaft Position Sensor Wire**

Pin	Size	Color	Circuit	Terminal Type ID	Option	Function	Pin	Size	Color	Circuit	Terminal Type ID	Option
1	0.5	GY / BU	5300	I	—	Intake Camshaft Position Sensor 1 Voltage Reference	1	0.5	GY / BU	5300	II	—
2	0.5	BK / GN	5301	I	—	Intake Camshaft Position Sensor Low Reference 1	2	0.5	BK / GN	5301	II	—
3	0.5	YE / VT	5275	I	—	Intake Camshaft Position Sensor 1	3	0.5	YE / VT	5275	II	—
4	0.5	BU	179	I	—	Engine Oil Pump Control	4	0.5	BU	179	II	—
5	0.5	VT / BN	5284	I	—	Intake Camshaft Position Actuator Solenoid Valve 1	5	0.5	VT / BN	5284	II	—
6	0.5	BK / BN	6753	I	—	Camshaft Position Actuator Solenoid Valve W Low Reference	6	0.5	BK / BN	6753	II	—

**X128 Engine Wiring Harness to Camshaft Position Sensor Wire (cont'd)**

Pin	Size	Color	Circuit	Terminal Type ID	Option	Function	Pin	Size	Color	Circuit	Terminal Type ID	Option
7	0.5	VT / BU	5293	I	—	Powertrain Main Relay Fused Supply Voltage 4	7	0.5	VT / BU	5293	II	—
8	—	—	—	—	—	Not Occupied	8	—	—	—	—	—

**X129 Camshaft Position Sensor Wiring Harness to Oil Pump Flow Control Solenoid Valve Wiring Harness (L87)**

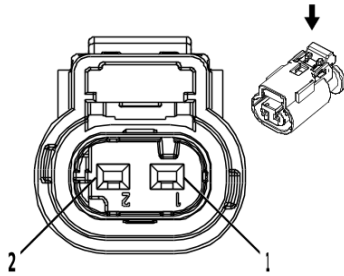

2717066

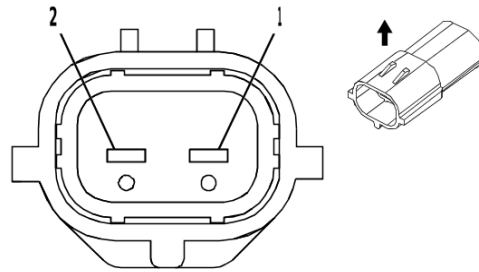

2684367

**Connector Part Information**

Harness Type: Camshaft Position Sensor Wiring Harness  
 OEM Connector: 13503566  
 Service Connector: Service by Harness - See Part Catalog  
 Description: 2-Way F 1.2 Multilock Series, Sealed( BK)

**Connector Part Information**

Harness Type: Oil Pump Flow Control Solenoid Valve Wiring Harness  
 OEM Connector: 12681015  
 Service Connector: Service by Harness - See Part Catalog  
 Description: 2-Way M ( BK)

**Terminal Part Information**

Terminal Type ID	Terminated Lead	Diagnostic Test Probe	Terminal Removal Tool
I	Not required	J-35616-12 (BU)	No Tool Required
II	Not required	Not Available	No Tool Required

**X129 Camshaft Position Sensor Wiring Harness to Oil Pump Flow Control Solenoid Valve Wiring Harness (L87)**

Pin	Size	Color	Circuit	Terminal Type ID	Option	Function	Pin	Size	Color	Circuit	Terminal Type ID	Option
1	0.5	VT / BU	5293	I	—	Powertrain Main Relay Fused Supply Voltage 4	1	0.5	VT / BU	5293	II	—
2	0.5	BU	179	I	—	Engine Oil Pump Control	2	0.5	BU	179	II	—

## X129 Engine Wiring Harness to Oil Pump Flow Control Solenoid Valve Wiring Harness (L3B)

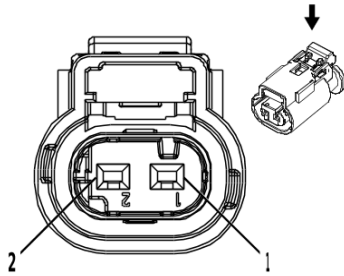

2717066

### Connector Part Information

Harness Type: Engine Wiring Harness  
 OEM Connector: 10010337  
 Service Connector: 13587326  
 Description: 2-Way F 1.2 Multilock Series, Sealed( BK)

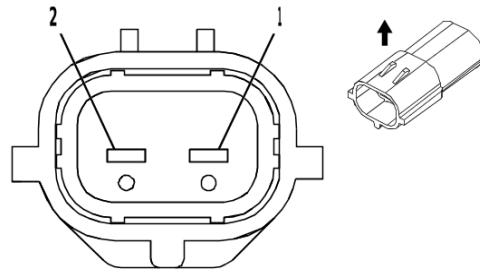

2684367

### Connector Part Information

Harness Type: Oil Pump Flow Control Solenoid Valve Wiring Harness  
 OEM Connector: 12681015  
 Service Connector: Service by Harness - See Part Catalog  
 Description: 2-Way M ( BK)

### Terminal Part Information

Terminal Type ID	Terminated Lead	Diagnostic Test Probe	Terminal Removal Tool
I	Not required	J-35616-16 (L-GN)	No Tool Required
II	Not required	No Tool Required	No Tool Required

## X129 Engine Wiring Harness to Oil Pump Flow Control Solenoid Valve Wiring Harness (L3B)

Pin	Size	Color	Circuit	Terminal Type ID	Option	Function	Pin	Size	Color	Circuit	Terminal Type ID	Option
1	0.5	YE / BN	106	I	—	Oil Pump Motor Control	1	0.5	YE / BN	106	II	—
2	0.5	BU	179	I	—	Engine Oil Pump Control	2	0.5	BU	179	II	—

**X129 Engine Wiring Harness to Oil Pump Flow Control Solenoid Valve Wiring Harness (LZ0)**

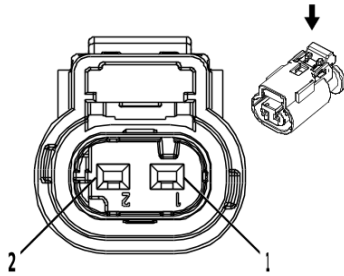

2717066

**Connector Part Information**

Harness Type: Engine Wiring Harness  
 OEM Connector: 10010337  
 Service Connector: 13587326  
 Description: 2-Way F 1.2 Multilock Series, Sealed( BK)

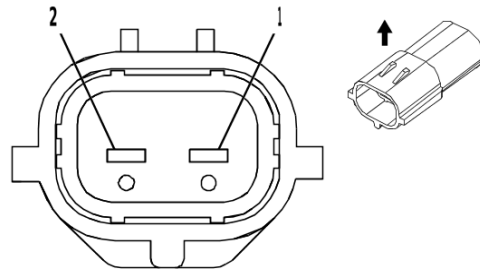

2684367

**Connector Part Information**

Harness Type: Oil Pump Flow Control Solenoid Valve Wiring Harness  
 OEM Connector: 12681015  
 Service Connector: Service by Harness - See Part Catalog  
 Description: 2-Way M ( BK)

**Terminal Part Information**

Terminal Type ID	Terminated Lead	Diagnostic Test Probe	Terminal Removal Tool
I	Not required	J-35616-16 (L-GN)	No Tool Required
II	Not required	No Tool Required	No Tool Required

**X129 Engine Wiring Harness to Oil Pump Flow Control Solenoid Valve Wiring Harness (LZ0)**

Pin	Size	Color	Circuit	Terminal Type ID	Option	Function	Pin	Size	Color	Circuit	Terminal Type ID	Option
1	0.5	YE / BN	106	I	—	Oil Pump Motor Control	1	0.5	YE / BN	106	II	—
2	0.5	BU	179	I	—	Engine Oil Pump Control	2	0.5	BU	179	II	—



**X150 Front Object Alarm Sensor Wiring Harness to Body Wiring Harness**

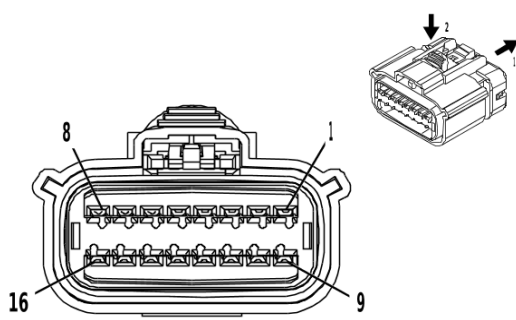

4253394

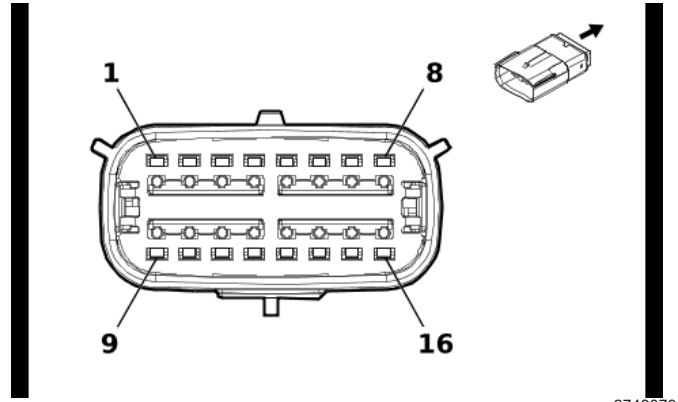

2748079

**Connector Part Information**

Harness Type: Front Object Alarm Sensor Wiring Harness  
 OEM Connector: 13590423  
 Service Connector: Service by Harness - See Part Catalog  
 Description: 16-Way F 1.5 OCS Series, Sealed( BK)

**Connector Part Information**

Harness Type: Body Wiring Harness  
 OEM Connector: 35589680  
 Service Connector: 26314575  
 Description: 16-Way M 1.5 OCS Series, Sealed( BK)

**Terminal Part Information**

Terminal Type ID	Terminated Lead	Diagnostic Test Probe	Terminal Removal Tool
I	Not required	J-35616-2A (GY)	No Tool Required
II	19352418	J-35616-3 (GY)	J-38125-215A

**X150 Front Object Alarm Sensor Wiring Harness to Body Wiring Harness**

Pin	Size	Color	Circuit	Terminal Type ID	Option	Function	Pin	Size	Color	Circuit	Terminal Type ID	Option
1	0.5	RD / GN	3140	I	—	Battery Positive Voltage	1	0.5	RD / GN	3140	II	—
2	—	—	—	—	—	Not Occupied	2	—	—	—	—	—
3	0.5	BK / BU	5214	I	—	Front Parking Assist Sensor Low Reference	3	0.5	BK / BU	5214	II	—
4	0.5	VT / WH	5215	I	—	Left Front Outer Parking Assist Sensor	4	0.5	VT / WH	5215	II	—
5	0.5	YE / GY	5216	I	—	Left Front Middle Parking Assist Sensor	5	0.5	YE / GY	5216	II	—
6	0.5	WH / GY	5217	I	—	Right Front Outer Parking Assist Sensor	6	0.5	WH / GY	5217	II	—
7	0.5	VT / GY	5218	I	—	Right Front Middle Parking Assist Sensor	7	0.5	VT / GY	5218	II	—
8	0.5	BK	650	I	—	Ground	8	0.5	BK	650	II	—
9	0.5	BK / WH	651	I	—	Signal Ground	9	0.5	BK / WH	651	II	—

## 6-764 Electrical Component and Inline Harness Connector End Views

### X150 Front Object Alarm Sensor Wiring Harness to Body Wiring Harness (cont'd)

Pin	Size	Color	Circuit	Terminal Type ID	Option	Function	Pin	Size	Color	Circuit	Terminal Type ID	Option
10	0.5	BN / GY	5061	I	—	Left Front Fog Lamp Control	10	0.5	BN / GY	5061	II	—
11	0.5	BN	6581	I	—	Front Parking Assist Display Control	11	0.5	BN	6581	II	—
12 - 14	—	—	—	—	—	Not Occupied	12 - 14	—	—	—	—	—
15	0.5	WH / GY	4104	I	—	AUTOSAR CAN Bus [-] 8 Serial Data	15	0.5	WH / GY	4104	II	—
16	0.5	BU / GY	4105	I	—	AUTOSAR CAN Bus [+] 8 Serial Data	16	0.5	BU / GY	4105	II	—

**X160 Engine Wiring Harness to Fuel Injector Wiring Harness (L3B)**

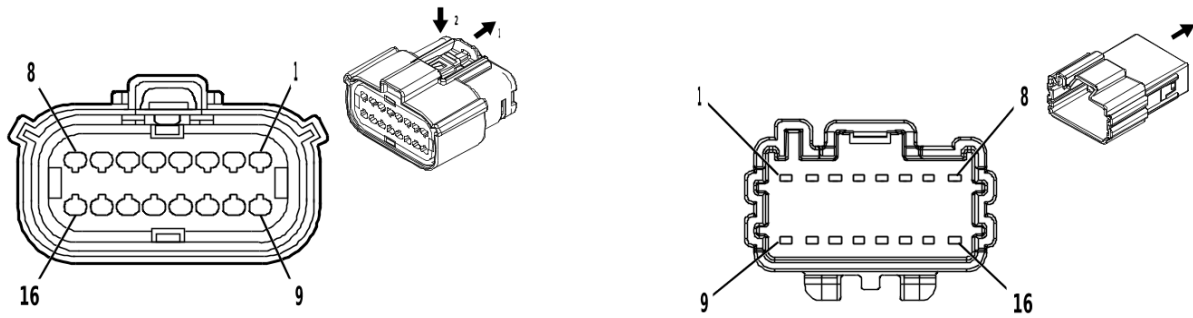

4574233

4223086

**Connector Part Information**

Harness Type: Engine Wiring Harness  
 OEM Connector: 33472-1866  
 Service Connector: 13584788  
 Description: 16-Way F 1.5 MX Series, Sealed( BK)

**Connector Part Information**

Harness Type: Fuel Injector Wiring Harness  
 OEM Connector: Not Available  
 Service Connector: Service by Harness - See Part Catalog  
 Description: 16-Way M ( BK)

**Terminal Part Information**

Terminal Type ID	Terminated Lead	Diagnostic Test Probe	Terminal Removal Tool
I	19368973	J-35616-2A (GY)	J-38125-217
II	Not required	No Tool Required	No Tool Required

**X160 Engine Wiring Harness to Fuel Injector Wiring Harness (L3B)**

Pin	Size	Color	Circuit	Terminal Type ID	Option	Function	Pin	Size	Color	Circuit	Terminal Type ID	Option
1	0.5	VT / GY	496	I	—	Knock Sensor 1 Signal	1	0.5	VT / GY	496	II	—
2	0.75	BN	4801	I	—	Direct Fuel Injector High Voltage Control Cylinder 1	2	0.75	BN	4801	II	—
3	0.5	WH / RD	480	I	—	Engine Control Vehicle Sensors 5 Volt Reference 1	3	0.5	WH / RD	480	II	—
4	0.75	GY / BU	4804	I	—	Direct Fuel Injector High Voltage Control Cylinder 4	4	0.75	GY / BU	4804	II	—
5	—	—	—	—	—	Not Occupied	5	—	—	—	—	—
6	0.75	GN	4803	I	—	Direct Fuel Injector High Voltage Control Cylinder 3	6	0.75	GN	4803	II	—
7	0.75	BU	4802	I	—	Direct Fuel Injector High Voltage Control Cylinder 2	7	0.75	BU	4802	II	—

**6-766 Electrical Component and Inline Harness Connector End Views**

**X160 Engine Wiring Harness to Fuel Injector Wiring Harness (L3B) (cont'd)**

Pin	Size	Color	Circuit	Terminal Type ID	Option	Function	Pin	Size	Color	Circuit	Terminal Type ID	Option
8	0.5	WH / GY	1876	I	—	Knock Sensor 2 Signal	8	0.5	WH / GY	1876	II	—
9	0.5	BK / YE	1716	I	—	Knock Sensor Low Reference 1	9	0.5	BK / YE	1716	II	—
10	0.75	BN / WH	4901	I	—	Direct Fuel Injector High Voltage Supply Cylinder 1	10	0.75	BN / WH	4901	II	—
11	0.5	BU / WH	10786	I	—	Fuel Rail Pressure Sensor SENT 1 Signal	11	0.5	BU / WH	10786	II	—
12	0.5	BK / GN	580	I	—	Engine Control Sensors Low Reference 2	12	0.5	BK / GN	580	II	—
13	0.75	BU / WH	4904	I	—	Direct Fuel Injector High Voltage Supply Cylinder 4	13	0.75	BU / WH	4904	II	—
14	0.75	GN / GY	4903	I	—	Direct Fuel Injector High Voltage Supply Cylinder 3	14	0.75	GN / GY	4903	II	—
15	0.75	BU / GY	4902	I	—	Direct Fuel Injector High Voltage Supply Cylinder 2	15	0.75	BU / GY	4902	II	—
16	0.5	BK / GY	2303	I	—	Knock Sensor Low Reference 2	16	0.5	BK / GY	2303	II	—

**X160 Engine Wiring Harness to Fuel Injector Wiring Harness (LZ0)**

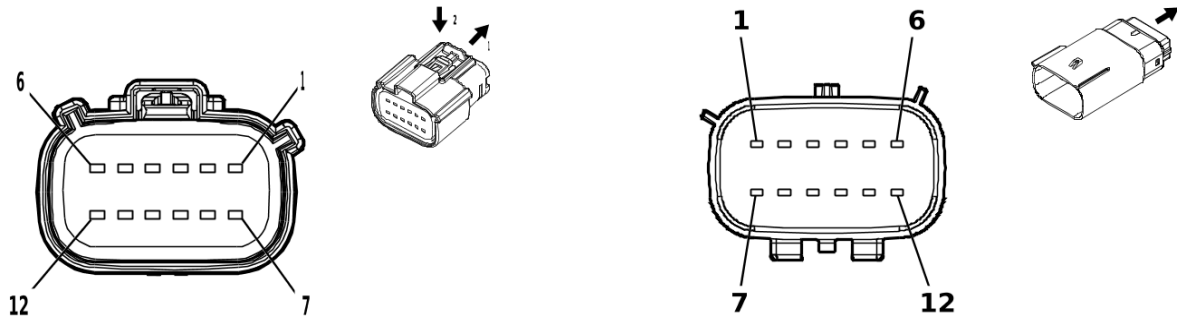

4584248

5187933

**Connector Part Information**

Harness Type: Engine Wiring Harness  
 OEM Connector: 33472-1259  
 Service Connector: 19333239  
 Description: 12-Way F 1.5 MX Series, Sealed( D-GY)

**Connector Part Information**

Harness Type: Fuel Injector Wiring Harness  
 OEM Connector: 33482-6261  
 Service Connector: Service by Harness - See Part Catalog  
 Description: 12-Way M 1.5 MX Series, Sealed( GY)

**Terminal Part Information**

Terminal Type ID	Terminated Lead	Diagnostic Test Probe	Terminal Removal Tool
I	85528055	J-35616-2A (GY)	J-38125-217
II	Not required	J-35616-3 (GY)	No Tool Required

**X160 Engine Wiring Harness to Fuel Injector Wiring Harness (LZ0)**

Pin	Size	Color	Circuit	Terminal Type ID	Option	Function	Pin	Size	Color	Circuit	Terminal Type ID	Option
1	1.5	BN / WH	4901	I	—	Direct Fuel Injector High Voltage Supply Cylinder 1	1	1.5	BN / WH	4901	II	—
2	1.5	BN	4801	I	—	Direct Fuel Injector High Voltage Control Cylinder 1	2	1.5	BN	4801	II	—
3	1.5	BU / GY	4902	I	—	Direct Fuel Injector High Voltage Supply Cylinder 2	3	1.5	BU / GY	4902	II	—
4	1.5	BU	4802	I	—	Direct Fuel Injector High Voltage Control Cylinder 2	4	1.5	BU	4802	II	—
5	1.5	GN / GY	4903	I	—	Direct Fuel Injector High Voltage Supply Cylinder 3	5	1.5	GN / GY	4903	II	—
6	1.5	GN	4803	I	—	Direct Fuel Injector High Voltage Control Cylinder 3	6	1.5	GN	4803	II	—

**6-768 Electrical Component and Inline Harness Connector End Views**

**X160 Engine Wiring Harness to Fuel Injector Wiring Harness (LZ0) (cont'd)**

Pin	Size	Color	Circuit	Terminal Type ID	Option	Function	Pin	Size	Color	Circuit	Terminal Type ID	Option
7	1.5	BU / WH	4904	I	—	Direct Fuel Injector High Voltage Supply Cylinder 4	7	1.5	BU / WH	4904	II	—
8	1.5	GY / BU	4804	I	—	Direct Fuel Injector High Voltage Control Cylinder 4	8	1.5	GY / BU	4804	II	—
9	1.5	GN / WH	4905	I	—	Direct Fuel Injector High Voltage Supply Cylinder 5	9	1.5	GN / WH	4905	II	—
10	1.5	WH / GN	4805	I	—	Direct Fuel Injector High Voltage Control Cylinder 5	10	1.5	WH / GN	4805	II	—
11	1.5	VT / GY	4906	I	—	Direct Fuel Injector High Voltage Supply Cylinder 6	11	1.5	VT / GY	4906	II	—
12	1.5	VT / GN	4806	I	—	Direct Fuel Injector High Voltage Control Cylinder 6	12	1.5	VT / GN	4806	II	—

**X160 Engine Wiring Harness to Fuel Injector Wiring Harness - Bank 1 (L84 / L87)**

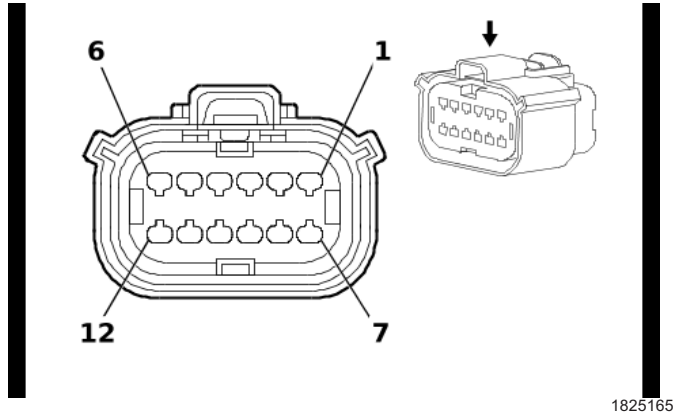

**Connector Part Information**

Harness Type: Engine Wiring Harness  
 OEM Connector: 33472-1216  
 Service Connector: 19352907  
 Description: 12-Way F 1.5 MX Series, Sealed( BK)

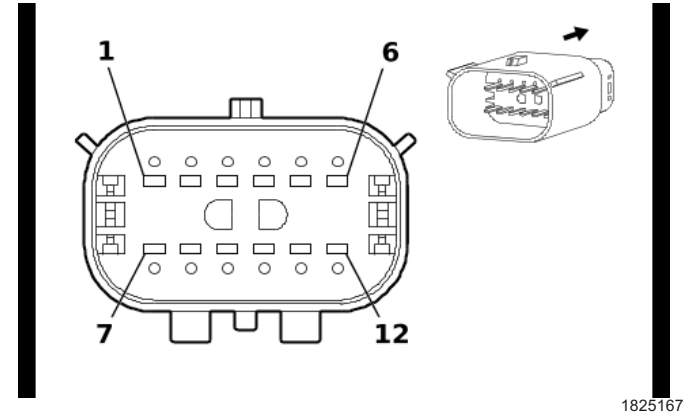

**Connector Part Information**

Harness Type: Fuel Injector Wiring Harness - Bank 1  
 OEM Connector: 334826206  
 Service Connector: Service by Harness - See Part Catalog  
 Description: 12-Way M 1.5 MX Series, Sealed( BK)

**Terminal Part Information**

Terminal Type ID	Terminated Lead	Diagnostic Test Probe	Terminal Removal Tool
I	19368973	J-35616-2A (GY)	J-38125-217
II	Not required	J-35616-3 (GY)	No Tool Required

**X160 Engine Wiring Harness to Fuel Injector Wiring Harness - Bank 1 (L84 / L87)**

Pin	Size	Color	Circuit	Terminal Type ID	Option	Function	Pin	Size	Color	Circuit	Terminal Type ID	Option
1	0.75	BN / WH	4901	I	—	Direct Fuel Injector High Voltage Supply Cylinder 1	1	0.8	BN / WH	4901	II	—
2	0.75	GN / BK	4903	I	—	Direct Fuel Injector High Voltage Supply Cylinder 3	2	0.8	GN / GY	4903	II	—
3	0.75	GN / WH	4905	I	—	Direct Fuel Injector High Voltage Supply Cylinder 5	3	0.8	GN / WH	4905	II	—
4	0.75	WH / YE	4907	I	—	Direct Fuel Injector High Voltage Supply Cylinder 7	4	0.8	WH / YE	4907	II	—
5	0.75	BN	4801	I	—	Direct Fuel Injector High Voltage Control Cylinder 1	5	0.8	BN	4801	II	—
6	—	—	—	—	—	Not Occupied	6	—	—	—	—	—

**6-770 Electrical Component and Inline Harness Connector End Views**

**X160 Engine Wiring Harness to Fuel Injector Wiring Harness - Bank 1 (L84 / L87) (cont'd)**

Pin	Size	Color	Circuit	Terminal Type ID	Option	Function	Pin	Size	Color	Circuit	Terminal Type ID	Option
7	0.75	GN	4803	I	—	Direct Fuel Injector High Voltage Control Cylinder 3	7	0.8	GN	4803	II	—
8	0.75	WH / GN	4805	I	—	Direct Fuel Injector High Voltage Control Cylinder 5	8	0.8	WH / GN	4805	II	—
9	0.75	YE / GY	4807	I	—	Direct Fuel Injector High Voltage Control Cylinder 7	9	0.8	YE / GY	4807	II	—
10	0.5	WH / RD	480	I	—	Engine Control Vehicle Sensors 5 Volt Reference 1	10	0.5	BN / RD	480	II	—
11	0.5	BU / WH	10786	I	—	Fuel Rail Pressure Sensor SENT 1 Signal	11	0.5	BU / WH	10786	II	—
12	0.5	BK / YE	548	I	—	Engine Control Sensors Low Reference 1	12	0.5	BK / GN	548	II	—



**X161 Engine Wiring Harness to Fuel Injector Wiring Harness - Bank 2 (L84 / L87)**

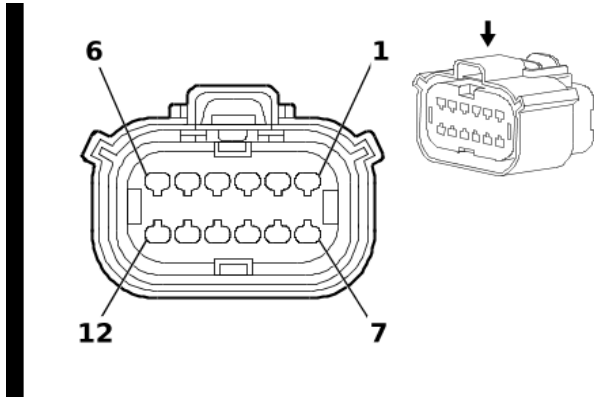

1825165

**Connector Part Information**

Harness Type: Engine Wiring Harness  
 OEM Connector: 33472-1226  
 Service Connector: 19352907  
 Description: 12-Way F 1.5 MX Series, Sealed( BK)

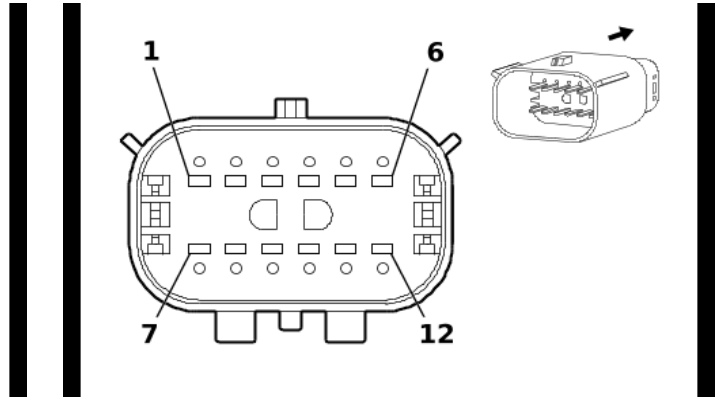

1825167

**Connector Part Information**

Harness Type: Fuel Injector Wiring Harness - Bank 2  
 OEM Connector: 334826211  
 Service Connector: Service by Harness - See Part Catalog  
 Description: 12-Way M 1.5 MX Series, Sealed( BK)

**Terminal Part Information**

Terminal Type ID	Terminated Lead	Diagnostic Test Probe	Terminal Removal Tool
I	19368973	J-35616-2A (GY)	J-38125-217
II	Not required	J-35616-3 (GY)	No Tool Required

**X161 Engine Wiring Harness to Fuel Injector Wiring Harness - Bank 2 (L84 / L87)**

Pin	Size	Color	Circuit	Terminal Type ID	Option	Function	Pin	Size	Color	Circuit	Terminal Type ID	Option
1	0.75	BU / BK	4902	I	—	Direct Fuel Injector High Voltage Supply Cylinder 2	1	0.8	BU / GY	4902	II	—
2	0.75	BU / WH	4904	I	—	Direct Fuel Injector High Voltage Supply Cylinder 4	2	0.8	BU / WH	4904	II	—
3	0.75	VT / GY	4906	I	—	Direct Fuel Injector High Voltage Supply Cylinder 6	3	0.8	VT / GY	4906	II	—
4	0.75	GY / WH	4908	I	—	Direct Fuel Injector High Voltage Supply Cylinder 8	4	0.8	GY / WH	4908	II	—
5	0.75	BU	4802	I	—	Direct Fuel Injector High Voltage Control Cylinder 2	5	0.8	BU	4802	II	—
6 - 7	—	—	—	—	—	Not Occupied	6 - 7	—	—	—	—	—

**6-772 Electrical Component and Inline Harness Connector End Views**

**X161 Engine Wiring Harness to Fuel Injector Wiring Harness - Bank 2 (L84 / L87) (cont'd)**

Pin	Size	Color	Circuit	Terminal Type ID	Option	Function	Pin	Size	Color	Circuit	Terminal Type ID	Option
8	0.75	GY / BU	4804	I	—	Direct Fuel Injector High Voltage Control Cylinder 4	8	0.8	GY / BU	4804	II	—
9	0.75	VT / GN	4806	I	—	Direct Fuel Injector High Voltage Control Cylinder 6	9	0.8	VT / GN	4806	II	—
10	0.75	GY	4808	I	—	Direct Fuel Injector High Voltage Control Cylinder 8	10	0.8	GY	4808	II	—
11	0.75	VT / BK	7300	I	—	High Pressure Fuel Pump Low Control	11	0.8	VT / BK	7300	II	—
12	0.75	YE	7301	I	—	High Pressure Fuel Pump High Control	12	0.8	YE	7301	II	—

### X162 Front Object Alarm Sensor Wiring Harness to Front Object Alarm Sensor Wiring Harness (UKL)

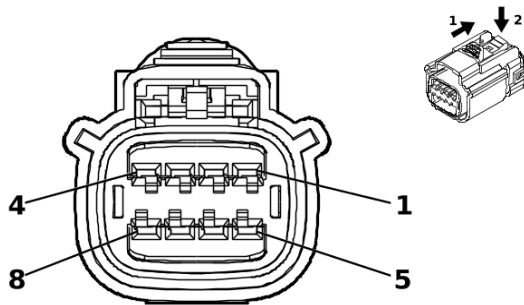

5253496

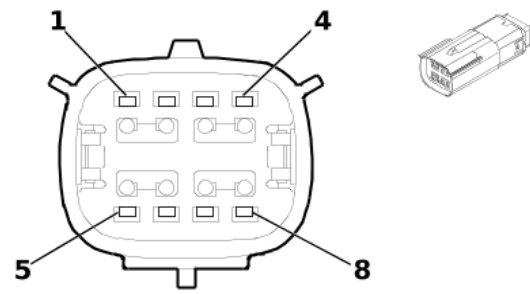

5402096

#### Connector Part Information

Harness Type: Front Object Alarm Sensor Wiring Harness  
 OEM Connector: 35507578  
 Service Connector: Service by Harness - See Part Catalog  
 Description: 8-Way F 1.5 OCS Series, Sealed( BK)

#### Connector Part Information

Harness Type: Front Object Alarm Sensor Wiring Harness  
 OEM Connector: 15514651  
 Service Connector: Service by Harness - See Part Catalog  
 Description: 8-Way M 1.5 OCS Series, Sealed( BK)

#### Terminal Part Information

Terminal Type ID	Terminated Lead	Diagnostic Test Probe	Terminal Removal Tool
I	Not required	J-35616-2A (GY)	No Tool Required
II	Not required	J-35616-3 (GY)	No Tool Required

### X162 Front Object Alarm Sensor Wiring Harness to Front Object Alarm Sensor Wiring Harness (UKL)

Pin	Size	Color	Circuit	Terminal Type ID	Option	Function	Pin	Size	Color	Circuit	Terminal Type ID	Option
1	0.5	RD / GN	3140	I	—	Battery Positive Voltage	1	0.5	RD / GN	3140	II	—
2	0.5	BK / WH	651	I	—	Signal Ground	2	0.5	BK / WH	651	II	—
3	0.5	BU / GY	4105	I	—	AUTOSAR CAN Bus [+] 8 Serial Data	3	0.5	BU / GY	4105	II	—
4	0.5	BU / GY	4105	I	—	AUTOSAR CAN Bus [+] 8 Serial Data	4	0.5	BU / GY	4105	II	—
5	0.5	BK / WH	651	I	—	Signal Ground	5	0.5	BK / WH	651	II	—
6	—	—	—	—	—	Not Occupied	6	—	—	—	—	—
7	0.5	WH / GY	4104	I	—	AUTOSAR CAN Bus [-] 8 Serial Data	7	0.5	WH / GY	4104	II	—
8	0.5	WH / GY	4104	I	—	AUTOSAR CAN Bus [-] 8 Serial Data	8	0.5	WH / GY	4104	II	—

X163 Engine Wiring Harness to Diesel Glow Plug Wiring Harness

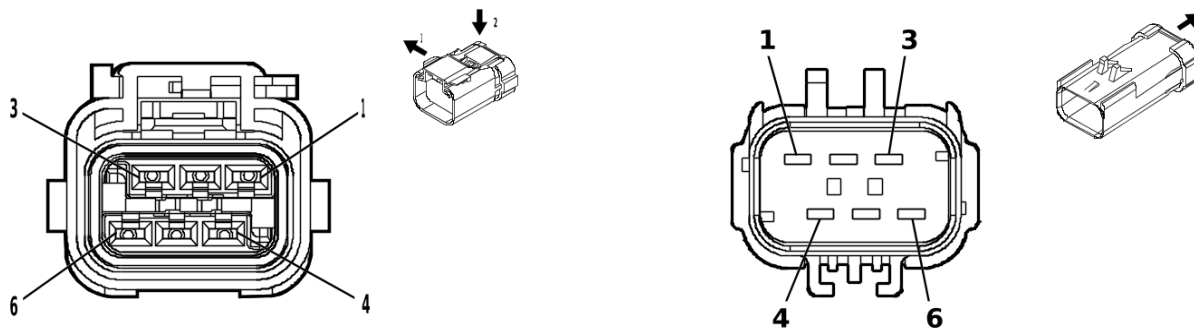

4997615

5187846

**Connector Part Information**

Harness Type: Engine Wiring Harness  
 OEM Connector: 15419838  
 Service Connector: 86825462  
 Description: 6-Way F 2.8 APEX Series, Sealed( BK)

**Connector Part Information**

Harness Type: Diesel Glow Plug Wiring Harness  
 OEM Connector: 54200612  
 Service Connector: Service by Harness - See Part Catalog  
 Description: 6-Way M 2.8 APEX Series, Sealed( BK)

**Terminal Part Information**

Terminal Type ID	Terminated Lead	Diagnostic Test Probe	Terminal Removal Tool
I	Not required	J-35616-4A (PU)	No Tool Required
II	Not required	J-35616-5 (PU)	No Tool Required

**X163 Engine Wiring Harness to Diesel Glow Plug Wiring Harness**

Pin	Size	Color	Circuit	Terminal Type ID	Option	Function	Pin	Size	Color	Circuit	Terminal Type ID	Option
1	2.5	GY / BU	1581	I	—	Glow Plug 1 Control	1	2.5	GY / RD	1581	II	—
2	2.5	GY / BN	1582	I	—	Glow Plug 2 Control	2	2.5	GY / BK	1582	II	—
3	2.5	GY / GN	1583	I	—	Glow Plug 3 Control	3	2.5	GY / GN	1583	II	—
4	2.5	GY / YE	1584	I	—	Glow Plug 4 Control	4	2.5	GY / YE	1584	II	—
5	2.5	GY / WH	1585	I	—	Glow Plug 5 Control	5	2.5	GY / WH	1585	II	—
6	2.5	GY / VT	1586	I	—	Glow Plug 6 Control	6	2.5	GY	1586	II	—

### X165 Front Object Alarm Sensor Wiring Harness to Front Object Alarm Sensor Wiring Harness - Jumper (UKL)

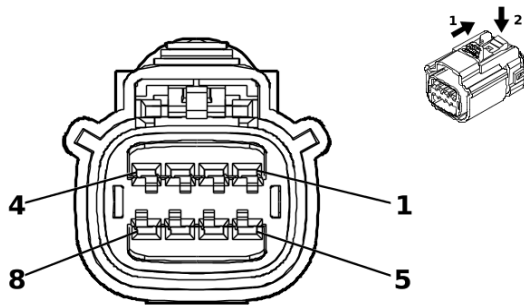

5253496

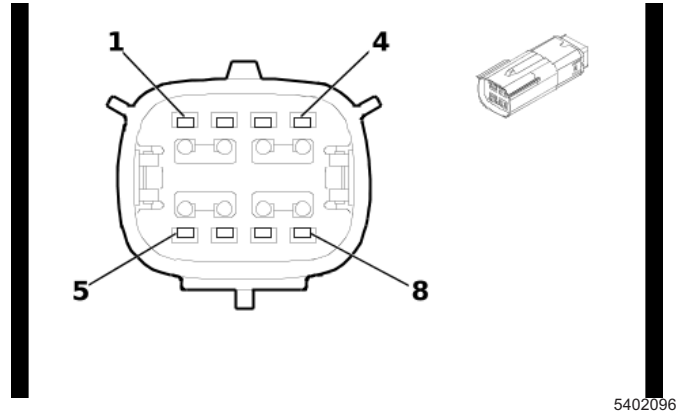

5402096

#### Connector Part Information

Harness Type: Front Object Alarm Sensor Wiring Harness  
 OEM Connector: 35507578  
 Service Connector: Service by Harness - See Part Catalog  
 Description: 8-Way F 1.5 OCS Series, Sealed( BK)

#### Connector Part Information

Harness Type: Front Object Alarm Sensor Wiring Harness - Jumper  
 OEM Connector: 15514651  
 Service Connector: Service by Harness - See Part Catalog  
 Description: 8-Way M 1.5 OCS Series, Sealed( BK)

#### Terminal Part Information

Terminal Type ID	Terminated Lead	Diagnostic Test Probe	Terminal Removal Tool
I	Not required	J-35616-2A (GY)	No Tool Required
II	Not required	J-35616-64B (L-BU)	No Tool Required

### X165 Front Object Alarm Sensor Wiring Harness to Front Object Alarm Sensor Wiring Harness - Jumper (UKL)

Pin	Size	Color	Circuit	Terminal Type ID	Option	Function	Pin	Size	Color	Circuit	Terminal Type ID	Option
1	0.5	RD / GN	3140	I	—	Battery Positive Voltage	1	0.5	BK / WH	651	II	—
2	—	—	—	—	—	Not Occupied	2	—	—	—	—	—
3	0.5	BU / GY	4105	I	—	AUTOSAR CAN Bus [+] 8 Serial Data	3	0.5	BK / WH	651	II	—
4	0.5	BU / GY	4105	I	—	AUTOSAR CAN Bus [+] 8 Serial Data	4	0.5	RD / GN	3140	II	—
5	0.5	BK / WH	651	I	—	Signal Ground	5	0.5	WH / GY	4104	II	—
6	—	—	—	—	—	AUTOSAR CAN Bus [+] 8 Serial Data	6	0.5	BU / GY	4105	II	—
7	0.5	WH / GY	4104	I	—	AUTOSAR CAN Bus [-] 8 Serial Data	7	0.5	WH / GY	4104	II	—
8	0.5	WH / GY	4104	I	—	AUTOSAR CAN Bus [-] 8 Serial Data	8	0.5	BU / GY	4105	II	—

**X175 Engine Wiring Harness to Automatic Transmission Wiring Harness - Case (MQC)**

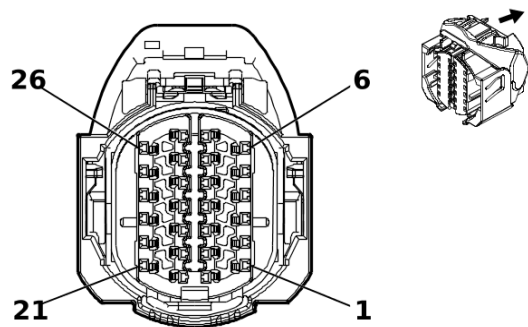

5275597

**Connector Part Information**

Harness Type: Engine Wiring Harness  
 OEM Connector: 2327375-1  
 Service Connector: 13528029  
 Description: 26-Way F 1.2 MCON Series, Sealed( BK)

**Connector Part Information**

Harness Type: Automatic Transmission Wiring Harness - Case  
 OEM Connector: Not Available  
 Service Connector: Service by Harness - See Part Catalog  
 Description: 26-Way M ( BK)

**Terminal Part Information**

Terminal Type ID	Terminated Lead	Diagnostic Test Probe	Terminal Removal Tool
I	19331733	J-35616-12 (BU)	J-38125-215A
II	84963773	J-35616-12 (BU)	J-38125-215A
III	Not required	No Tool Required	No Tool Required

**X175 Engine Wiring Harness to Automatic Transmission Wiring Harness - Case (MQC)**

Pin	Size	Color	Circuit	Terminal Type ID	Option	Function	Pin	Size	Color	Circuit	Terminal Type ID	Option
1	0.5	GN / YE	6353	I	—	Input Speed Signal	1	0.5	GN / YE	6353	III	—
2	0.5	GN / VT	4510	I	—	Transmission Intermediate Speed Signal	2	0.5	GN / VT	4510	III	—
3	0.5	BN / WH	6254	I	—	Transmission Input Speed Sensor Signal	3	0.5	BN / WH	6254	III	—
4	0.5	GY / BU	6358	I	—	Output Speed Signal	4	0.5	GY / BU	6358	III	—
5	0.5	WH / YE	6317	I	—	Electronic Transmission Range Select Out of Park Switch Signal	5	0.5	WH / YE	6317	III	—
6	0.5	VT / WH	6319	I	—	Electronic Transmission Range Select Out of Park Switch 2 Signal	6	0.5	VT / WH	6319	III	—

**X175 Engine Wiring Harness to Automatic Transmission Wiring Harness - Case (MQC)  
(cont'd)**

Pin	Size	Color	Circuit	Terminal Type ID	Option	Function	Pin	Size	Color	Circuit	Terminal Type ID	Option
7	0.5	YE / GN	4170	I	—	Transmission Output Shaft Speed Sensor Circuit 9V Reference	7	0.5	YE / GN	4170	III	—
8	0.5	YE / BU	4171	I	—	Transmission Input Shaft Speed Sensor Circuit 9V Reference	8	0.5	YE / BU	4171	III	—
9	0.5	GY / BN	6388	I	—	Transmission High Side Driver 2 Control	9	0.5	GY / BN	6388	III	—
10	1.5	RD / GY	8540	II	—	Battery Positive Voltage	10	1.5	RD / GY	8540	III	—
11	0.5	GN / GY	6387	I	—	Transmission High Side Driver 1 Control	11	0.5	GN / GY	6387	III	—
12	0.5	WH / YE	2159	I	—	Park Inhibit Solenoid Assembly Control	12	0.5	WH / YE	2159	III	—
13	0.5	BN / WH	585	I	—	Transmission Fluid Temperature Sensor Signal	13	0.5	BN / WH	585	III	—
14	0.5	YE / BN	6404	I	—	Clutch Solenoid Valve E Control	14	0.5	YE / BN	6404	III	—
15	0.5	GY / GN	6403	I	—	Clutch Solenoid Valve D Control	15	0.5	GY / GN	6403	III	—
16	0.5	GY	6402	I	—	Clutch Solenoid Valve C Control	16	0.5	GY	6402	III	—
17	1.5	BK	450	II	—	Ground	17	1.5	BK	450	III	—
18	0.5	GN / WH	2968	I	—	Transmission Auxiliary Fluid Pump Control	18	0.5	GN / WH	2968	III	—
19	0.5	GN / BK	7819	I	—	Default Disable Solenoid Control	19	0.5	GN / BK	7819	III	—
20	0.5	BN	3706	I	—	Electronic Transmission Range Select Switch Analog Signal 1	20	0.5	BN	3706	III	—
21	0.5	VT	4509	I	—	Transmission Clutch F Control	21	0.5	VT	4509	III	—
22	0.5	WH / BU	4507	I	—	Transmission Clutch H Control	22	0.5	WH / BU	4507	III	—
23	0.5	WH	4508	I	—	Transmission Clutch G Control	23	0.5	WH	4508	III	—

**6-778 Electrical Component and Inline Harness Connector End Views**

**X175 Engine Wiring Harness to Automatic Transmission Wiring Harness - Case (MQC)  
(cont'd)**

Pin	Size	Color	Circuit	Terminal Type ID	Option	Function	Pin	Size	Color	Circuit	Terminal Type ID	Option
24	0.5	GN / WH	1530	I	—	Transmission Line Pressure Control Solenoid Valve Control	24	0.5	GN / WH	1530	III	—
25	0.5	VT / WH	422	I	—	Torque Converter Clutch Solenoid Valve Control	25	0.5	VT / WH	422	III	—
26	0.5	BK / BN	586	I	—	Transmission Fluid Temperature Sensor Low Reference	26	0.5	BK / BN	586	III	—



### X175 Engine Wiring Harness to Automatic Transmission Wiring Harness - Case (MQE)

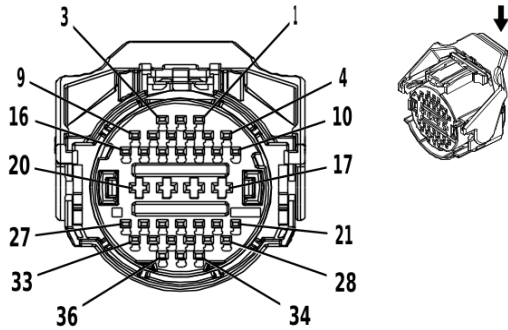

3621473

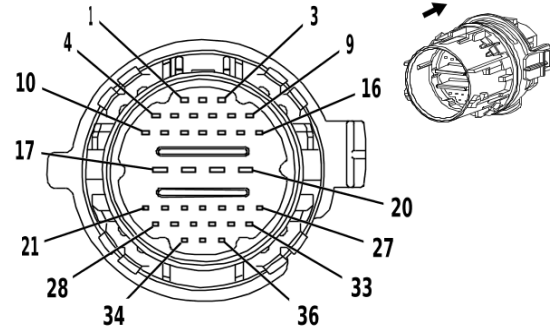

3977661

#### Connector Part Information

Harness Type: Engine Wiring Harness  
 OEM Connector: 2138314-1  
 Service Connector: 19329922  
 Description: 36-Way F 1.2 MCON-CB, 2.8 MCP Series, Sealed( BK)

#### Connector Part Information

Harness Type: Automatic Transmission Wiring Harness - Case  
 OEM Connector: Not Available  
 Service Connector: Service by Harness - See Part Catalog  
 Description: 36-Way M ( BK)

#### Terminal Part Information

Terminal Type ID	Terminated Lead	Diagnostic Test Probe	Terminal Removal Tool
I	13575368	J-35616-35 (VT)	J-38125-36
II	19300445	J-35616-12 (BU)	J-38125-11A
III	Not required	No Tool Required	No Tool Required

### X175 Engine Wiring Harness to Automatic Transmission Wiring Harness - Case (MQE)

Pin	Size	Color	Circuit	Terminal Type ID	Option	Function	Pin	Size	Color	Circuit	Terminal Type ID	Option
1	0.5	GN / WH	6380	II	—	Torque Converter Clutch Enable Solenoid Valve A Control	1	0.5	GN / WH	6380	III	—
2	—	—	—	—	—	Not Occupied	2	—	—	—	—	—
3	0.5	VT / WH	422	II	—	Torque Converter Clutch Solenoid Valve Control	3	0.5	VT / WH	422	III	—
4	0.5	GN / WH	1530	II	—	Transmission Line Pressure Control Solenoid Valve Control	4	0.5	GN / WH	1530	III	—
5	0.5	BN	6400	II	—	Clutch Solenoid Valve A Control	5	0.5	BN	6400	III	—
6	0.5	BU	6401	II	—	Clutch Solenoid Valve B Control	6	0.5	BU	6401	III	—

**6-780 Electrical Component and Inline Harness Connector End Views**
**X175 Engine Wiring Harness to Automatic Transmission Wiring Harness - Case (MQE)  
(cont'd)**

Pin	Size	Color	Circuit	Terminal Type ID	Option	Function	Pin	Size	Color	Circuit	Terminal Type ID	Option
7	0.5	YE / BN	6210	II	—	Torque Converter Clutch Enable Solenoid Valve B Control	7	0.5	YE / BN	6210	III	—
8	0.5	GN / WH	2968	II	—	Transmission Auxiliary Fluid Pump Control	8	0.5	GN / WH	2968	III	—
9	—	—	—	—	—	Not Occupied	9	—	—	—	—	—
10	0.5	GY	6402	II	—	Clutch Solenoid Valve C Control	10	0.5	GY	6402	III	—
11	0.5	BK / BN	586	II	—	Transmission Fluid Temperature Sensor Low Reference	11	0.5	BK / BN	586	III	—
12	0.5	BN / WH	585	II	—	Transmission Fluid Temperature Sensor Signal	12	0.5	BN / WH	585	III	—
13	0.5	WH	4508	II	—	Transmission Clutch G Control	13	0.5	WH	4508	III	—
14	0.5	WH / BU	4507	II	—	Transmission Clutch H Control	14	0.5	WH / BU	4507	III	—
15 - 16	—	—	—	—	—	Not Occupied	15 - 16	—	—	—	—	—
17	1.5	RD / GY	8540	I	—	Battery Positive Voltage	17	1.5	RD / GY	8540	III	—
18	0.5	GN / GY	6387	I	—	Transmission High Side Driver 1 Control	18	0.5	GN / GY	6387	III	—
19	0.5	GY / BN	6388	I	—	Transmission High Side Driver 2 Control	19	0.5	GY / BN	6388	III	—
20	1.5	BK	450	I	—	Ground	20	1.5	BK	450	III	—
21	0.5	GN / YE	3337	II	—	Transmission Internal Mode Switch Mode Control Y	21	0.5	GN / YE	3337	III	—
22	0.5	BU / WH	3338	II	—	Transmission Internal Mode Switch Mode Control X	22	0.5	BU / WH	3338	III	—
23	—	—	—	—	—	Not Occupied	23	—	—	—	—	—
24	0.5	GY / BU	6358	II	—	Output Speed Signal	24	0.5	GY / BU	6358	III	—

**X175 Engine Wiring Harness to Automatic Transmission Wiring Harness - Case (MQE)  
(cont'd)**

Pin	Size	Color	Circuit	Terminal Type ID	Option	Function	Pin	Size	Color	Circuit	Terminal Type ID	Option
25	0.5	YE / GN	4170	II	—	Transmission Output Shaft Speed Sensor Circuit 9V Reference	25	0.5	YE / GN	4170	III	—
26	0.5	GN / YE	6353	II	—	Input Speed Signal	26	0.5	GN / YE	6353	III	—
27	0.5	YE / BU	4171	II	—	Transmission Input Shaft Speed Sensor Circuit 9V Reference	27	0.5	YE / BU	4171	III	—
28	—	—	—	—	—	Not Occupied	28	—	—	—	—	—
29	0.5	WH / RD	480	II	—	Engine Control Vehicle Sensors 5 Volt Reference 1	29	0.5	WH / RD	480	III	—
30	0.5	BK / GY	626	II	—	Engine Control Vehicle Sensors Low Reference 1	30	0.5	BK / GY	626	III	—
31	—	—	—	—	—	Not Occupied	31	—	—	—	—	—
32	0.5	GN / VT	4510	II	—	Transmission Intermediate Speed Signal	32	0.5	GN / VT	4510	III	—
33	—	—	—	—	—	Not Occupied	33	—	—	—	—	—
34	0.5	GY / RD	10817	II	—	Lubricant Circuit Pressure Sensor 5 Volt Reference	34	0.5	GY / RD	10817	III	—
35	0.5	BU / BK	10819	II	—	Lubricant Circuit Pressure Sensor Low Reference	35	0.5	BU / BK	10819	III	—
36	0.5	GN / YE	10816	II	—	Lubricant Circuit Pressure Sensor Signal	36	0.5	GN / YE	10816	III	—

**X176 Automatic Transmission Wiring Harness - Case to Automatic Transmission Wiring Harness - Control (MHS / MQC)**

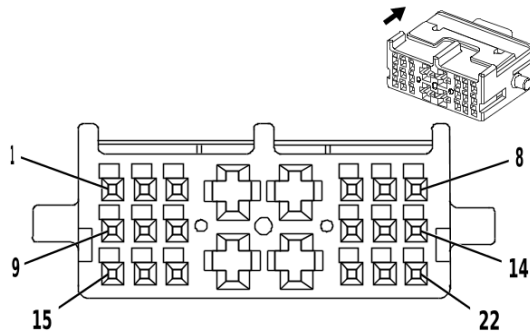

3977748

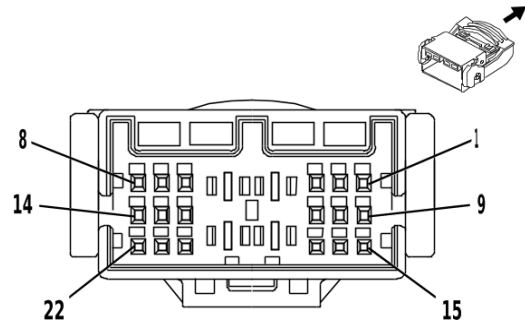

3977770

**Connector Part Information**

Harness Type: Automatic Transmission Wiring Harness - Case  
 OEM Connector: 1897543-1  
 Service Connector: Service by Harness - See Part Catalog  
 Description: 22-Way F 0.64 Micro-Quadlock, 2.8 Micro-Power Series( NA)

**Connector Part Information**

Harness Type: Automatic Transmission Wiring Harness - Control  
 OEM Connector: 1897540-1  
 Service Connector: Service by Harness - See Part Catalog  
 Description: 22-Way M 0.64 Micro-Quadlock, 2.8 Micro-Power Series( NA)

**Terminal Part Information**

Terminal Type ID	Terminated Lead	Diagnostic Test Probe	Terminal Removal Tool
I	Not required	J-35616-35 (VT)	No Tool Required
II	Not required	J-35616-64B (L-BU)	No Tool Required
III	Not required	J-35616-5 (PU)	No Tool Required
IV	Not required	J-35616-65B (L-BU)	No Tool Required

**X176 Automatic Transmission Wiring Harness - Case to Automatic Transmission Wiring Harness - Control (MHS / MQC)**

Pin	Size	Color	Circuit	Terminal Type ID	Option	Function	Pin	Size	Color	Circuit	Terminal Type ID	Option
1	0.5	VT	7819	II	—	Default Disable Solenoid Control	1	0.5	VT	7819	IV	—
2	0.5	GN / OG	1530	II	—	Transmission Line Pressure Control Solenoid Valve Control	2	0.5	GN / OG	1530	IV	—
3	0.5	GY / BN	422	II	—	Torque Converter Clutch Solenoid Valve Control	3	0.5	GY / BN	422	IV	—
4	0.5	BN	6387	I	—	Transmission High Side Driver 1 Control	4	0.5	BN	6387	III	—
5	—	—	—	—	—	Not Occupied	5	—	—	—	—	—
6	0.5	YE	6317	II	—	Electronic Transmission Range Select	6	0.5	YE	6317	IV	—

**X176 Automatic Transmission Wiring Harness - Case to Automatic Transmission Wiring Harness - Control (MHS / MQC) (cont'd)**

Pin	Size	Color	Circuit	Terminal Type ID	Option	Function	Pin	Size	Color	Circuit	Terminal Type ID	Option
						Out of Park Switch Signal						
7	0.5	YE / GY	6319	II	—	Electronic Transmission Range Select Out of Park Switch 2 Signal	7	0.5	YE / GY	6319	IV	—
8	0.5	GN	4170	II	—	Transmission Output Shaft Speed Sensor Circuit 9V Reference	8	0.5	GN	4170	IV	—
9	0.5	OG	2159	II	—	Park Inhibit Solenoid Assembly Control	9	0.5	OG	2159	IV	—
10	0.5	BK / GY	3706	II	—	Electronic Transmission Range Select Switch Analog Signal 1	10	0.5	BK / GY	3706	IV	—
11	0.5	BU	4171	II	—	Transmission Input Shaft Speed Sensor Circuit 9V Reference	11	0.5	BU	4171	IV	—
12	—	—	—	—	—	Not Occupied	12	—	—	—	—	—
13	0.5	BU / BN	586	II	—	Transmission Fluid Temperature Sensor Low Reference	13	0.5	BU / BN	586	IV	—
14	0.5	BN / YE	585	II	—	Transmission Fluid Temperature Sensor Signal	14	0.5	BN / YE	585	IV	—
15	0.5	BU / GN	6404	II	—	Clutch Solenoid Valve E Control	15	0.5	BU / GN	6404	IV	—
16	0.5	GN / BN	6403	II	—	Clutch Solenoid Valve D Control	16	0.5	GN / BN	6403	IV	—
17	0.5	GY	6402	II	—	Clutch Solenoid Valve C Control	17	0.5	GY	6402	IV	—
18	0.5	WH	6388	I	—	Transmission High Side Driver 2 Control	18	0.5	WH	6388	III	—
19	—	—	—	—	—	Not Occupied	19	—	—	—	—	—
20	0.5	BN / WH	4509	II	—	Transmission Clutch F Control	20	0.5	BN / WH	4509	IV	—

**6-784 Electrical Component and Inline Harness Connector End Views****X176 Automatic Transmission Wiring Harness - Case to Automatic Transmission Wiring Harness - Control (MHS / MQC) (cont'd)**

Pin	Size	Color	Circuit	Terminal Type ID	Option	Function	Pin	Size	Color	Circuit	Terminal Type ID	Option
21	0.5	YE / VT	4507	II	—	Transmission Clutch H Control	21	0.5	YE / VT	4507	IV	—
22	0.5	BU / GY	4508	II	—	Transmission Clutch G Control	22	0.5	BU / GY	4508	IV	—

**X176 Automatic Transmission Wiring Harness - Case to Automatic Transmission Wiring Harness - Control (MHT / MI2 / MQB)**

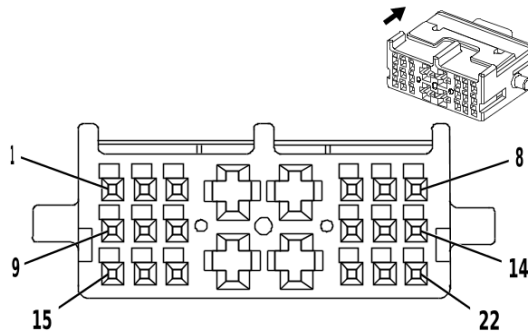

3977748

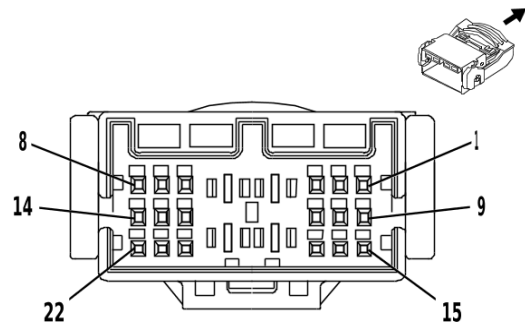

3977770

**Connector Part Information**

Harness Type: Automatic Transmission Wiring Harness - Case  
 OEM Connector: 1897543-1  
 Service Connector: Service by Harness - See Part Catalog  
 Description: 22-Way F 0.64 Micro-Quadlock, 2.8 Micro-Power Series( NA)

**Connector Part Information**

Harness Type: Automatic Transmission Wiring Harness - Control  
 OEM Connector: 1897540-1  
 Service Connector: Service by Harness - See Part Catalog  
 Description: 22-Way M 0.64 Micro-Quadlock, 2.8 Micro-Power Series( NA)

**Terminal Part Information**

Terminal Type ID	Terminated Lead	Diagnostic Test Probe	Terminal Removal Tool
I	Not required	J-35616-35 (VT)	No Tool Required
II	Not required	J-35616-64B (L-BU)	No Tool Required
III	Not required	J-35616-65B (L-BU)	No Tool Required

**X176 Automatic Transmission Wiring Harness - Case to Automatic Transmission Wiring Harness - Control (MHT / MI2 / MQB)**

Pin	Size	Color	Circuit	Terminal Type ID	Option	Function	Pin	Size	Color	Circuit	Terminal Type ID	Option
1	0.5	VT	7819	II	—	Default Disable Solenoid Control	1	0.5	VT	7819	III	—
2	0.5	GN / OG	1530	II	—	Transmission Line Pressure Control Solenoid Valve Control	2	0.5	GN / OG	1530	III	—
3	0.5	GY / BN	422	II	—	Torque Converter Clutch Solenoid Valve Control	3	0.5	GY / BN	422	III	—
4	0.5	BN	6387	I	—	Transmission High Side Driver 1 Control	4	0.5	BN	6387	III	—
5-12	—	—	—	—	—	Not Occupied	5-12	—	—	—	—	—
13	0.5	BU / BN	586	II	—	Transmission Fluid Temperature Sensor Low Reference	13	0.5	BU / BN	586	III	—

**6-786 Electrical Component and Inline Harness Connector End Views**

**X176 Automatic Transmission Wiring Harness - Case to Automatic Transmission Wiring Harness - Control (MHT / MI2 / MQB) (cont'd)**

Pin	Size	Color	Circuit	Terminal Type ID	Option	Function	Pin	Size	Color	Circuit	Terminal Type ID	Option
14	0.5	BN / YE	585	II	—	Transmission Fluid Temperature Sensor Signal	14	0.5	BN / YE	585	III	—
15	0.5	BU / GN	6404	II	—	Clutch Solenoid Valve E Control	15	0.5	BU / GN	6404	III	—
16	0.5	GN / BN	6403	II	—	Clutch Solenoid Valve D Control	16	0.5	GN / BN	6403	III	—
17	0.5	GY	6402	II	—	Clutch Solenoid Valve C Control	17	0.5	GY	6402	III	—
18	0.5	WH	6388	I	—	Transmission High Side Driver 2 Control	18	0.5	WH	6388	III	—
19	—	—	—	—	—	Not Occupied	19	—	—	—	—	—
20	0.5	BN / WH	4509	II	—	Transmission Clutch F Control	20	0.5	BN / WH	4509	III	—
21	0.5	YE / VT	4507	II	—	Transmission Clutch H Control	21	0.5	YE / VT	4507	III	—
22	0.5	BU / GY	4508	II	—	Transmission Clutch G Control	22	0.5	BU / GY	4508	III	—



**X176 Automatic Transmission Wiring Harness - Case to Automatic Transmission Wiring Harness - Control (MQE)**

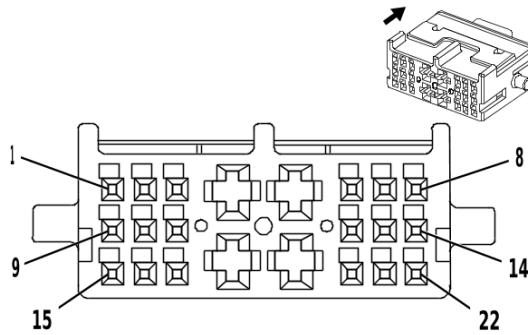

3977748

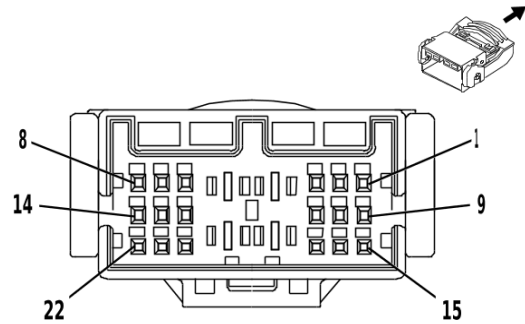

3977770

**Connector Part Information**

Harness Type: Automatic Transmission Wiring Harness - Case  
 OEM Connector: 1897543-1  
 Service Connector: Service by Harness - See Part Catalog  
 Description: 22-Way F 0.64 Micro-Quadlock, 2.8 Micro-Power Series( NA)

**Connector Part Information**

Harness Type: Automatic Transmission Wiring Harness - Control  
 OEM Connector: 1897540-1  
 Service Connector: Service by Harness - See Part Catalog  
 Description: 22-Way M 0.64 Micro-Quadlock, 2.8 Micro-Power Series( NA)

**Terminal Part Information**

Terminal Type ID	Terminated Lead	Diagnostic Test Probe	Terminal Removal Tool
I	Not required	J-35616-35 (VT)	No Tool Required
II	Not required	J-35616-64B (L-BU)	No Tool Required
III	Not required	J-35616-5 (PU)	No Tool Required
IV	Not required	J-35616-65B (L-BU)	No Tool Required

**X176 Automatic Transmission Wiring Harness - Case to Automatic Transmission Wiring Harness - Control (MQE)**

Pin	Size	Color	Circuit	Terminal Type ID	Option	Function	Pin	Size	Color	Circuit	Terminal Type ID	Option
1	0.5	GN / WH	6380	II	—	Torque Converter Clutch Enable Solenoid Valve A Control	1	0.5	GN / WH	6380	IV	—
2	0.5	VT / WH	3338	II	—	Transmission Internal Mode Switch Mode Control X	2	0.5	VT / WH	3338	IV	—
3	—	—	—	—	—	Not Occupied	3	—	—	—	—	—
4	2.5	GN / GY	6387	I	—	Transmission High Side Driver 1 Control	4	2.5	GN / GY	6387	III	—
5	0.5	YE / RD	480	I	—	Engine Control Vehicle Sensors 5 Volt Reference 1	5	0.5	YE / RD	480	III	—

### X176 Automatic Transmission Wiring Harness - Case to Automatic Transmission Wiring Harness - Control (MQE) (cont'd)

Pin	Size	Color	Circuit	Terminal Type ID	Option	Function	Pin	Size	Color	Circuit	Terminal Type ID	Option
6	—	—	—	—	—	Not Occupied	6	—	—	—	—	—
7	0.5	WH / BU	4507	II	—	Transmission Clutch H Control	7	0.5	WH / BU	4507	IV	—
8	0.5	GY / GN	1530	II	—	Transmission Line Pressure Control Solenoid Valve Control	8	0.5	GY / GN	1530	IV	—
9	0.5	WH	4508	II	—	Transmission Clutch G Control	9	0.5	WH	4508	IV	—
10	0.5	YE / BN	6210	II	—	Torque Converter Clutch Enable Solenoid Valve B Control	10	0.5	YE / BN	6210	IV	—
11	0.5	WH / BK	3337	II	—	Transmission Internal Mode Switch Mode Control Y	11	0.5	WH / BK	3337	IV	—
12	—	—	—	—	—	Not Occupied	12	—	—	—	—	—
13	0.5	GY	6402	II	—	Clutch Solenoid Valve C Control	13	0.5	GY	6402	IV	—
14	0.5	YE / BN	422	II	—	Torque Converter Clutch Solenoid Valve Control	14	0.5	YE / BN	422	IV	—
15	0.5	BN / WH	585	II	—	Transmission Fluid Temperature Sensor Signal	15	0.5	BK / BN	585	IV	—
16	0.5	BK / BN	586	II	—	Transmission Fluid Temperature Sensor Low Reference	16	0.5	BK / BN	586	IV	—
17	—	—	—	—	—	Not Occupied	17	—	—	—	—	—
18	2.5	GY / BN	6388	I	—	Transmission High Side Driver 2 Control	18	2.5	GY / BN	6388	III	—
19	—	—	—	—	—	Not Occupied	19	—	—	—	—	—
20	0.5	BK / GY	626	II	—	Engine Control Vehicle Sensors Low Reference 1	20	0.5	BK / GY	626	IV	—
21	0.5	BN	6400	II	—	Clutch Solenoid Valve A Control	21	0.5	BN	6400	IV	—
22	0.5	BU	6401	II	—	Clutch Solenoid Valve B Control	22	0.5	BU	6401	IV	—

**X177 Automatic Transmission Wiring Harness - Case to Automatic Transmission Output Speed Sensor Wiring Harness (MQE)**

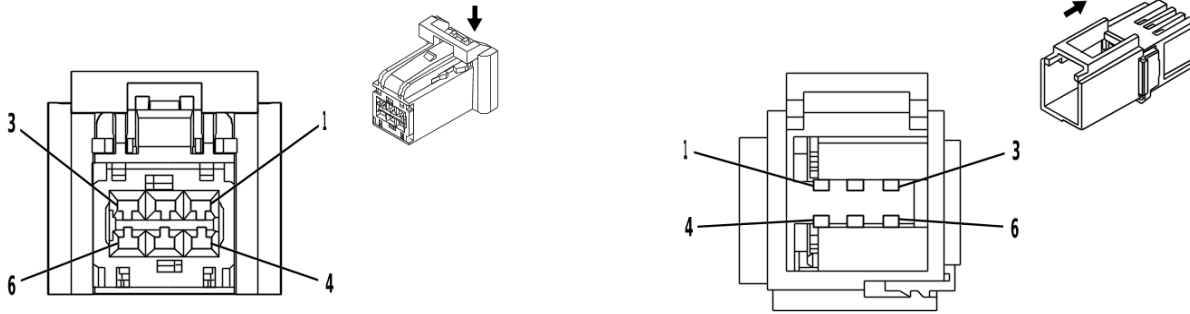

3977938

3977959

**Connector Part Information**

Harness Type: Automatic Transmission Wiring Harness - Case  
 OEM Connector: 13582377  
 Service Connector: Service by Harness - See Part Catalog  
 Description: 6-Way F 1.2 OCS Series( NA)

**Connector Part Information**

Harness Type: Automatic Transmission Output Speed Sensor Wiring Harness  
 OEM Connector: 13955963  
 Service Connector: Service by Harness - See Part Catalog  
 Description: 6-Way M 0.64 II Series( GY)

**Terminal Part Information**

Terminal Type ID	Terminated Lead	Diagnostic Test Probe	Terminal Removal Tool
I	Not required	J-35616-16 (L-GN)	No Tool Required
II	Not required	J-35616-65B (L-BU)	No Tool Required

**X177 Automatic Transmission Wiring Harness - Case to Automatic Transmission Output Speed Sensor Wiring Harness (MQE)**

Pin	Size	Color	Circuit	Terminal Type ID	Option	Function	Pin	Size	Color	Circuit	Terminal Type ID	Option
1	0.5	GY / BU	6358	I	—	Output Speed Signal	1	0.5	YE	6358	II	—
2	0.5	YE / GN	4170	I	—	Transmission Output Shaft Speed Sensor Circuit 9V Reference	2	0.5	RD	4170	II	—
3	0.5	YE / GN	4170	I	—	Transmission Output Shaft Speed Sensor Circuit 9V Reference	3	0.5	WH	4170	II	—
4	0.5	WH / RD	4171	I	—	Transmission Input Shaft Speed Sensor Circuit 9V Reference	4	0.5	WH	4171	II	—
5	0.5	GN / YE	6253	I	—	Transmission Input Speed Sensor Ground	5	0.5	GN	6253	II	—
6	0.5	GN / VT	4510	I	—	Transmission Intermediate Speed Signal	6	0.5	BK	4510	II	—

**X177 Automatic Transmission Wiring Harness - Control Extension to Automatic Transmission Wiring Harness - Control (MHS / MQC)**

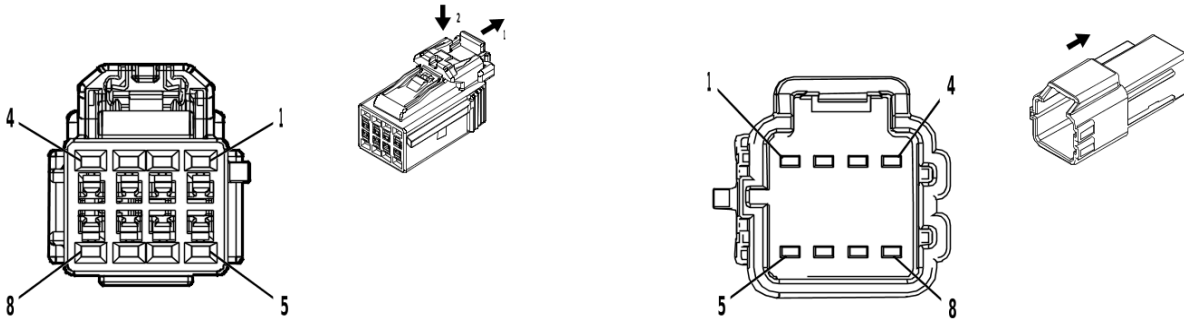

5086387

4331672

**Connector Part Information**

Harness Type: Automatic Transmission Wiring Harness - Control Extension  
 OEM Connector: 6098-8632  
 Service Connector: Service by Harness - See Part Catalog  
 Description: 8-Way F 1.2 Series

**Connector Part Information**

Harness Type: Automatic Transmission Wiring Harness - Control  
 OEM Connector: 6098-8630  
 Service Connector: Service by Harness - See Part Catalog  
 Description: 8-Way M 1.2 Series

**Terminal Part Information**

Terminal Type ID	Terminated Lead	Diagnostic Test Probe	Terminal Removal Tool
I	Not required	J-35616-12 (BU)	No Tool Required
II	Not required	J-35616-13 (BU)	No Tool Required

**X177 Automatic Transmission Wiring Harness - Control Extension to Automatic Transmission Wiring Harness - Control (MHS / MQC)**

Pin	Size	Color	Circuit	Terminal Type ID	Option	Function	Pin	Size	Color	Circuit	Terminal Type ID	Option
1	0.5	BN	6387	I	—	Transmission High Side Driver 1 Control	1	0.5	BN	6387	II	—
2	0.5	GN / OG	1530	I	—	Transmission Line Pressure Control Solenoid Valve Control	2	0.5	GN / OG	1530	II	—
3	0.5	GY / BN	422	I	—	Torque Converter Clutch Solenoid Valve Control	3	0.5	GY / BN	422	II	—
4	0.5	VT	7819	I	—	Default Disable Solenoid Control	4	0.5	VT	7819	II	—
5	0.5	BK / GY	3706	I	—	Electronic Transmission Range Select Switch Analog Signal 1	5	0.5	BK / GY	3706	II	—
6	0.5	BU	4171	I	—	Transmission Input Shaft Speed Sensor Circuit 9V Reference	6	0.5	BU	4171	II	—

**X177 Automatic Transmission Wiring Harness - Control Extension to Automatic  
Transmission Wiring Harness - Control (MHS / MQC) (cont'd)**

Pin	Size	Color	Circuit	Terminal Type ID	Option	Function	Pin	Size	Color	Circuit	Terminal Type ID	Option
7	0.5	WH	6388	I	—	Transmission High Side Driver 2 Control	7	0.5	WH	6388	II	—
8	—	—	—	—	—	Not Occupied	8	—	—	—	—	—

**X177 Automatic Transmission Wiring Harness - Control Extension to Automatic Transmission Wiring Harness - Control (MHT / MI2 / MQB)**

**Connector Part Information**

Harness Type: Automatic Transmission Wiring Harness - Control Extension  
 OEM Connector: 6098-8427  
 Service Connector: Service by Harness - See Part Catalog  
 Description: 6-Way F SUMITOMO

**Connector Part Information**

Harness Type: Automatic Transmission Wiring Harness - Control  
 OEM Connector: 6098-8429  
 Service Connector: Service by Harness - See Part Catalog  
 Description: 6-Way M SUMITOMO SLV WIR CONN FEM

**Terminal Part Information**

Terminal Type ID	Terminated Lead	Diagnostic Test Probe	Terminal Removal Tool
I	Not required	J-35616-12 (BU)	No Tool Required
II	Not required	J-35616-13 (BU)	No Tool Required

**X177 Automatic Transmission Wiring Harness - Control Extension to Automatic Transmission Wiring Harness - Control (MHT / MI2 / MQB)**

Pin	Size	Color	Circuit	Terminal Type ID	Option	Function	Pin	Size	Color	Circuit	Terminal Type ID	Option
1	0.5	BN	6387	I	—	Transmission High Side Driver 1 Control	1	0.5	BN	6387	II	—
2	0.5	GN / OG	1530	I	—	Transmission Line Pressure Control Solenoid Valve Control	2	0.5	GN / OG	1530	II	—
3	0.5	GY / BN	422	I	—	Torque Converter Clutch Solenoid Valve Control	3	0.5	GY / BN	422	II	—
4	0.5	VT	7819	I	—	Default Disable Solenoid Control	4	0.5	VT	7819	II	—
5	0.5	WH	6388	I	—	Transmission High Side Driver 2 Control	5	0.5	WH	6388	II	—

## X210 Instrument Panel Wiring Harness to Body Wiring Harness

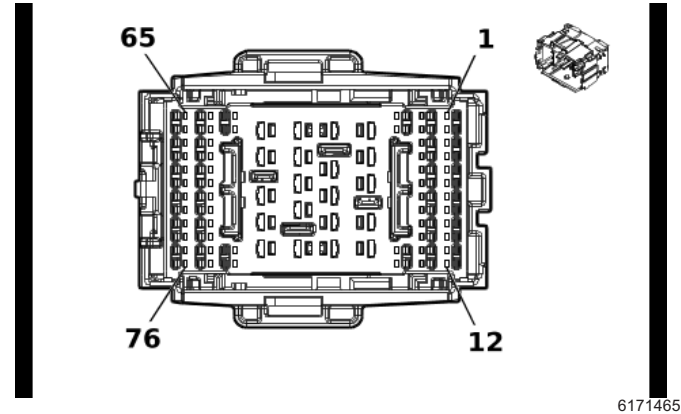
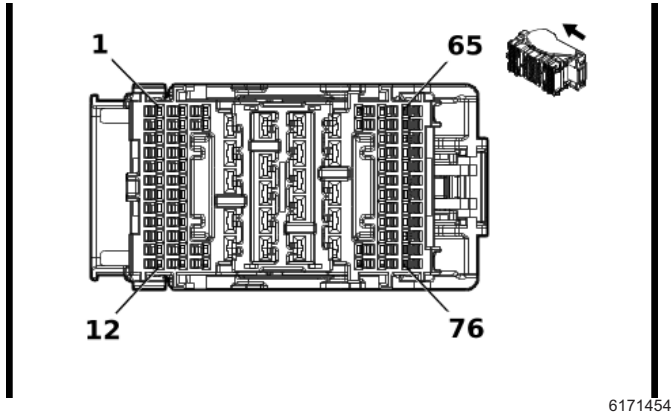

### Connector Part Information

Harness Type: Instrument Panel Wiring Harness  
 OEM Connector: 6099-0188  
 Service Connector: 85026856  
 Description: 76-Way F 1.2 Sumitomo, 2.8 YESC Series( BK)

### Connector Part Information

Harness Type: Body Wiring Harness  
 OEM Connector: 6099-0184  
 Service Connector: 13549030  
 Description: 76-Way M 1.2 Sumitomo, 2.8 YESC Series( BK)

### Terminal Part Information

Terminal Type ID	Terminated Lead	Diagnostic Test Probe	Terminal Removal Tool
I	84962854	J-35616-12 (BU)	J-38125-215A
II	84962855	J-35616-4A (PU)	J-38125-11A
III	84616651	J-35616-13 (BU)	J-38125-215A
IV	84888592	J-35616-5 (PU)	J-38125-11A

### X210 Instrument Panel Wiring Harness to Body Wiring Harness

Pin	Size	Color	Circuit	Terminal Type ID	Option	Function	Pin	Size	Color	Circuit	Terminal Type ID	Option
1	0.5	RD / GN	1540	I	—	Battery Positive Voltage	1	0.5	RD / GN	1540	III	—
2	0.5	RD / YE	6540	I	—	Battery Positive Voltage	2	0.5	RD / YE	6540	III	—
3	0.5	BN / OG	3020	I	—	Steering Wheel Air Bag Stage 1 Low Control	3	0.35	BN / OG	3020	III	—
4	0.5	OG / VT	3021	I	—	Steering Wheel Air Bag Stage 1 High Control	4	0.35	OG / VT	3021	III	—
5	0.5	WH / OG	3022	I	—	Steering Wheel Air Bag Stage 2 Low Control	5	0.35	WH / OG	3022	III	—
6	0.5	OG / GN	3023	I	—	Steering Wheel Air Bag Stage 2 High Control	6	0.35	OG / GN	3023	III	—
7	0.35	BN / WH	28	I	—	Horn Relay Control	7	0.35	BN / WH	28	III	—
8	—	—	—	—	—	Not Used	8	0.35	YE	900	III	—
9	—	—	—	—	—	Not Used	9	0.35	YE	901	III	—

**6-794 Electrical Component and Inline Harness Connector End Views**

**X210 Instrument Panel Wiring Harness to Body Wiring Harness (cont'd)**

Pin	Size	Color	Circuit	Terminal Type ID	Option	Function	Pin	Size	Color	Circuit	Terminal Type ID	Option
10	—	—	—	—	—	Not Used	10	0.35	YE	902	III	—
11 - 12	—	—	—	—	—	Not Occupied	11 - 12	—	—	—	—	—
13	0.35	BN / BK	3552	I	—	Interior Passive Entry Antenna 1 High Signal	13	0.35	BN / BK	3552	III	—
14	0.35	WH	3553	I	—	Interior Passive Entry Antenna 1 Low Signal	14	0.35	WH	3553	III	—
15	0.35	WH	4100	I	—	AUTOSAR CAN Bus [-] 4 Serial Data	15	0.5	WH	4100	III	—
16	0.35	BU / VT	4101	I	—	AUTOSAR CAN Bus [+] 4 Serial Data	16	0.5	BU / VT	4101	III	—
17	0.35	WH	4976	I	—	AUTOSAR CAN Bus [-] 3 Serial Data	17	0.5	WH	4976	III	—
18	0.35	BU / BK	4977	I	—	AUTOSAR CAN Bus [+] 3 Serial Data	18	0.5	BU / BK	4977	III	—
19 - 20	—	—	—	—	—	Not Occupied	19 - 20	—	—	—	—	—
21	0.35	BU / YE	4984	I	—	AUTOSAR CAN Bus [-] 5 Serial Data	21	0.5	BU / YE	4984	III	—
22	0.35	BU / WH	4985	I	—	AUTOSAR CAN Bus [+] 5 Serial Data	22	0.5	BU / WH	4985	III	—
23	0.35	WH	4986	I	—	AUTOSAR CAN Bus [-] 1 Serial Data	23	0.5	WH	4986	III	—
24	0.35	BU	4987	I	—	AUTOSAR CAN Bus [+] 1 Serial Data	24	0.5	BU	4987	III	—
25 - 26	—	—	—	—	—	Not Occupied	25 - 26	—	—	—	—	—
27	0.35	BN / BK	4996	I	—	Immobilizer Antenna Signal [+]	27	0.35	BN / BK	4996	III	—
28	0.35	WH / GY	4997	I	—	Immobilizer Antenna Low Signal	28	0.35	WH / GY	4997	III	—
29	2.5	RD / BN	4142	II	—	Primary Fused Battery Positive Voltage	29	2.5	RD / BN	4142	IV	—
30	0.5	GY	1715	II	—	Windshield Wiper Switch High Signal	30	0.35	GY	1715	IV	—
31	0.5	GN / YE	2731	II	—	Brake System Control Module LIN Bus 1	31	0.5	GN / YE	2731	IV	—



**X210 Instrument Panel Wiring Harness to Body Wiring Harness (cont'd)**

Pin	Size	Color	Circuit	Terminal Type ID	Option	Function	Pin	Size	Color	Circuit	Terminal Type ID	Option
32	0.35	BU / BN	4987	II	—	AUTOSAR CAN Bus [+] 1 Serial Data	32	0.5	BU	4987	IV	—
33	0.35	WH / RD	4986	II	—	AUTOSAR CAN Bus [-] 1 Serial Data	33	0.5	WH	4986	IV	—
34	—	—	—	—	—	Not Occupied	34	—	—	—	—	—
35	0.75	GN / BK	116	II	—	Left Rear Speaker [-] Control	35	0.75	GN / BK	116	IV	—
36	0.75	GN	199	II	—	Left Rear Speaker [+] Control	36	0.75	GN	199	IV	—
37	0.75	BN / BU	118	II	—	Left Front Speaker [-] Control 1	37	0.75	BN / BU	118	IV	—
38	0.75	BU	201	II	—	Left Front Speaker 1 [+] Control	38	0.75	BU	201	IV	—
39	—	—	—	—	—	Not Occupied	39	—	—	—	—	—
40	0.35	BU / WH	3119	II	—	Roof Rail Air Bag Disable Switch Signal	40	0.35	BU / WH	3119	IV	—
41	0.35	BN / WH	3895	II	—	Roof Rail Air Bag Disable Switch Low Reference	41	0.35	BN / WH	3895	IV	—
42	—	—	—	—	—	Not Occupied	42	—	—	—	—	—
43	0.5	GN / GY	4627	II	—	Image Processing Module LIN Bus 1	43	0.5	GN / GY	4627	IV	—
44	—	—	—	—	—	Not Occupied	44	—	—	—	—	—
45	0.35	GN / VT	4786	II	—	Dome/Reading Lamp Enable Signal	45	0.5	GN / VT	4786	IV	—
46	0.35	GN / BN	507	II	—	Wait To Start Indicator Control	46	0.35	GN / BN	507	IV	—
47	—	—	—	—	—	Not Occupied	47	—	—	—	—	—
48	0.5	YE / VT	6191	II	—	Power Rear Window Switch Open Signal	48	0.5	YE / VT	6191	IV	—
49	0.5	WH	6192	I	—	Sliding Rear Window Switch Close Signal	49	0.5	WH	6192	III	—
50	0.5	YE	6817	I	—	LED Backlight Dimming Control 1	50	0.5	YE	6817	III	—

**6-796 Electrical Component and Inline Harness Connector End Views**

**X210 Instrument Panel Wiring Harness to Body Wiring Harness (cont'd)**

Pin	Size	Color	Circuit	Terminal Type ID	Option	Function	Pin	Size	Color	Circuit	Terminal Type ID	Option
51	0.35	WH / GY	7297	I	—	Minor Endgate High Relay Control	51	0.75	WH / GY	7297	III	—
52	0.5	GN / WH	7530	I	—	Driver Seat Adjuster Memory Module LIN Bus 1	52	0.5	GN / WH	7530	III	—
53	0.5	RD / VT	7140	I	—	Battery Positive Voltage	53	0.5	RD / VT	7140	III	—
54	0.35	WH / GN	7728	I	—	Major Endgate High Relay Control	54	0.75	WH / GN	7728	III	—
55	0.35	BU / VT	7729	I	—	Major Endgate Low Relay Control	55	0.75	BU / VT	7729	III	—
56	0.5	VT	801	I	—	Retained Accessory Power Control	56	0.35	VT	801	III	—
57	0.5	BN / YE	820	I	—	Center High Mounted Stop Lamp Supply Voltage	57	0.5	BN / YE	820	III	—
58	0.35	GN / BU	2733	I	—	Brake System Control Module LIN Bus 2	58	0.5	GN / BU	2733	III	—
59	0.5	RD / VT	2640	I	—	Battery Positive Voltage	59	0.5	RD / VT	2640	III	—
60	0.35	BU / OG	4984	I	—	AUTOSAR CAN Bus [-] 5 Serial Data	60	0.5	BU / YE	4984	III	—
61	0.35	BU / WH	4985	I	—	AUTOSAR CAN Bus [+] 5 Serial Data	61	0.5	BU / WH	4985	III	—
62	—	—	—	—	—	Not Occupied	62	—	—	—	—	—
63	0.5	RD / GN	7740	I	—	Battery Positive Voltage	63	0.5	RD / GN	7740	III	—
64	—	—	—	—	—	Not Occupied	64	—	—	—	—	—
65	0.35	GN / GY	817	I	—	Vehicle Speed Signal	65	0.35	GN / GY	817	III	—
66	0.35	WH / GY	2935	I	—	Task Lamp Switch Signal	66	0.35	WH / GY	2935	III	—
67	0.5	RD / YE	2340	I	—	Battery Positive Voltage	67	0.5	RD / YE	2340	III	—
68	0.5	WH / VT	1430	I	—	Exterior Courtesy Lamp Control	68	0.5	WH / VT	1430	III	—
69	0.5	GN / WH	2854	I	—	Body Control Module LIN Bus 8	69	0.35	GN / WH	2854	III	—
70	0.5	BU / BN	6807	I	—	DC/AC Inverter Control	70	0.5	BU / BN	6807	III	—

**X210 Instrument Panel Wiring Harness to Body Wiring Harness (cont'd)**

Pin	Size	Color	Circuit	Terminal Type ID	Option	Function	Pin	Size	Color	Circuit	Terminal Type ID	Option
71	0.5	VT / RD	4049	I	—	AC Power Outlet Sensor High Reference	71	0.5	VT / RD	4049	III	—
72 - 73	—	—	—	—	—	Not Occupied	72 - 73	—	—	—	—	—
74	0.35	Bare	10116	I	—	AC Outlet Low Reference	74	0.35	Bare	10116	III	—
75	0.75	BK	10117	I	—	AC Outlet Phase A Control	75	0.75	BK	10117	III	—
76	0.75	RD	10118	I	—	AC Outlet Phase B Control	76	0.75	RD	10118	III	—

**X211 Instrument Panel Wiring Harness to Body Wiring Harness**

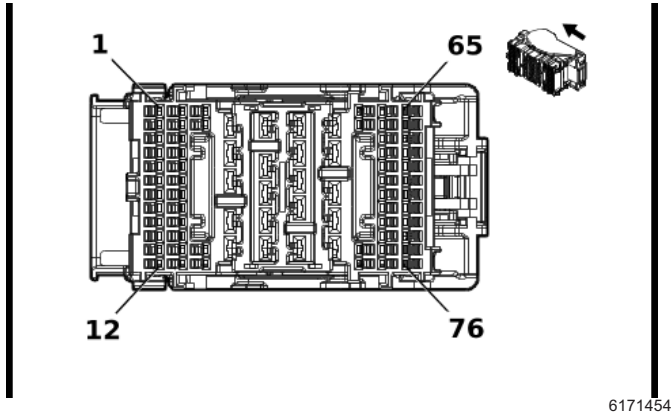

**Connector Part Information**

Harness Type: Instrument Panel Wiring Harness  
 OEM Connector: 6099-0188  
 Service Connector: 85026856  
 Description: 76-Way F 1.2 Sumitomo, 2.8 YESC Series( BK)

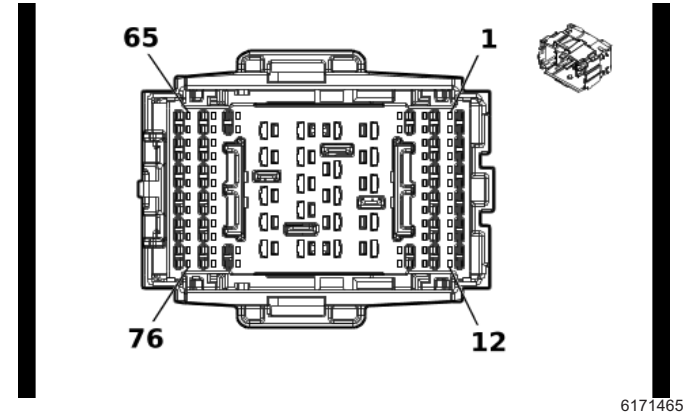

**Connector Part Information**

Harness Type: Body Wiring Harness  
 OEM Connector: 6099-0184  
 Service Connector: 13549030  
 Description: 76-Way M 1.2 Sumitomo, 2.8 YESC Series( BK)

**Terminal Part Information**

Terminal Type ID	Terminated Lead	Diagnostic Test Probe	Terminal Removal Tool
I	84962854	J-35616-12 (BU)	J-38125-215A
II	84962855	J-35616-4A (PU)	J-38125-11A
III	84616651	J-35616-13 (BU)	J-38125-215A
IV	84888592	J-35616-5 (PU)	J-38125-11A

**X211 Instrument Panel Wiring Harness to Body Wiring Harness**

Pin	Size	Color	Circuit	Terminal Type ID	Option	Function	Pin	Size	Color	Circuit	Terminal Type ID	Option
1	0.5	VT / BK	339	I	—	Run/Crank Ignition 1 Voltage	1	0.5	VT / BK	339	III	—
2	0.35	BU / VT	807	I	—	Ignition Off/ Accessory Ignition Voltage	2	0.35	BU / VT	807	III	—
3	—	—	—	—	—	Not Occupied	3	—	—	—	—	—
4	0.5	GN / WH	24	I	—	Backup Lamp Control	4	0.5	GN / WH	24	III	—
5	0.35	OG / WH	3024	I	—	Passenger Instrument Panel Air Bag Stage 1 Low Control	5	0.35	OG / WH	3024	III	—
6	0.35	YE / OG	3025	I	—	Passenger Instrument Panel Air Bag Stage 1 High Control	6	0.35	YE / OG	3025	III	—

**X211 Instrument Panel Wiring Harness to Body Wiring Harness (cont'd)**

Pin	Size	Color	Circuit	Terminal Type ID	Option	Function	Pin	Size	Color	Circuit	Terminal Type ID	Option
7	0.35	OG / VT	3026	I	—	Passenger Instrument Panel Air Bag Stage 2 Low Control	7	0.35	OG / VT	3026	III	—
8	0.35	GY / OG	3027	I	—	Passenger Instrument Panel Air Bag Stage 2 High Control	8	0.35	GY / OG	3027	III	—
9 - 15	—	—	—	—	—	Not Occupied	9 - 15	—	—	—	—	—
16	0.35	GN / BN	3005	I	—	Active Noise Cancellation Microphone 1 Signal	16	0.35	GN / WH	3005	III	—
17	0.35	GN / BK	3008	I	—	Active Noise Cancellation Microphone 1 Feedback Signal	17	0.35	GN / BK	3008	III	—
18 - 19	—	—	—	—	—	Not Occupied	18 - 19	—	—	—	—	—
20	0.35	WH / YE	4104	I	—	AUTOSAR CAN Bus [-] 8 Serial Data	20	0.5	WH / GY	4104	III	—
21	0.35	BU / GN	4105	I	—	AUTOSAR CAN Bus [+] 8 Serial Data	21	0.5	BU / GY	4105	III	—
22	0.5	WH / GY	4104	I	—	AUTOSAR CAN Bus [-] 8 Serial Data	22	0.5	WH / GY	4104	III	—
23	0.5	BU / GY	4105	I	—	AUTOSAR CAN Bus [+] 8 Serial Data	23	0.5	BU / GY	4105	III	—
24	—	—	—	—	—	Not Occupied	24	—	—	—	—	—
25	0.35	BU / BK	4987	I	—	AUTOSAR CAN Bus [+] 1 Serial Data	25	0.5	BU	4987	III	—
26	0.35	WH / YE	4986	I	—	AUTOSAR CAN Bus [-] 1 Serial Data	26	0.5	WH	4986	III	—
27 - 28	—	—	—	—	—	Not Occupied	27 - 28	—	—	—	—	—
29	1	GN / YE	6840	II	—	Auxiliary Device 2 Switched Voltage	29	1	GN / YE	6840	IV	—
30 - 31	—	—	—	—	—	Not Occupied	30 - 31	—	—	—	—	—
32	0.5	BU / BK	1053	II	—	Center High Mounted Stop Lamp Control 3	32	0.5	BU / BK	1053	IV	—

**6-800 Electrical Component and Inline Harness Connector End Views**

**X211 Instrument Panel Wiring Harness to Body Wiring Harness (cont'd)**

Pin	Size	Color	Circuit	Terminal Type ID	Option	Function	Pin	Size	Color	Circuit	Terminal Type ID	Option
33	0.75	WH	46	II	—	Right Rear Speaker [+] Control	33	0.75	WH	46	IV	—
34	0.75	BU / BK	115	II	—	Right Rear Speaker [-] Control	34	0.75	BU / BK	115	IV	—
35	0.75	YE / BK	117	II	—	Right Front Speaker [-] Control 1	35	0.75	YE / BK	117	IV	—
36	0.75	YE	200	II	—	Right Front Speaker 1 [+] Control	36	0.75	YE	200	IV	—
37	0.75	YE / BK	117	II	—	Right Front Speaker [-] Control 1	37	0.75	YE / BK	117	IV	—
38	0.75	YE	200	II	—	Right Front Speaker 1 [+] Control	38	0.75	YE	200	IV	—
39	0.75	YE / BK	117	II	—	Right Front Speaker [-] Control 1	39	0.75	YE / BK	117	IV	—
40	0.75	YE	200	II	—	Right Front Speaker 1 [+] Control	40	0.75	YE	200	IV	—
41	0.75	WH / YE	1853	II	—	Right Front Midrange Speaker [+] Control	41	0.75	WH / YE	1853	IV	—
42	0.75	BN / BK	1953	II	—	Right Front Midrange Speaker [-] Control	42	0.75	BN / BK	1953	IV	—
43	0.75	YE / WH	1860	II	—	Front Center Speaker [+] Control	43	0.75	YE / WH	1860	IV	—
44	0.75	BU / YE	1960	II	—	Front Center Speaker [-] Control	44	0.75	BU / YE	1960	IV	—
45	0.75	BU / VT	1857	II	—	Left Front Midrange Speaker [+] Control	45	0.75	BU / VT	1857	IV	—
46	0.75	BU / BN	1957	II	—	Left Front Midrange Speaker [-] Control	46	0.75	BU / BN	1957	IV	—
47	2	BU	47	II	—	Trailer Auxiliary Control	47	2	BU	47	IV	—
48	2.5	BK / WH	1051	II	—	Signal Ground Signal Ground	48	0.5 2.5	BK / WH BK / WH	1051 1051	IV IV	D07- ( IOK/ UQA) IOK- D07
49	0.35 0.35	BU / RD BU / YE	4979 4979	I I	UGN UHY	AUTOSAR CAN Bus [+] 2 Serial Data AUTOSAR CAN Bus [+] 2 Serial Data	49	0.5	BU / YE	4979	III	—

**X211 Instrument Panel Wiring Harness to Body Wiring Harness (cont'd)**

Pin	Size	Color	Circuit	Terminal Type ID	Option	Function	Pin	Size	Color	Circuit	Terminal Type ID	Option
50	0.35	WH / BN WH	4978	I	UGN UHY	AUTOSAR CAN Bus [-] 2 Serial Data	50	0.5	WH	4978	III	—
	0.35		4978	I								
51	0.35	VT / GY	7117	I	—	Front Axle Differential Lock Indicator Control	51	0.35	VT / GY	7117	III	—
52	0.35	YE	7115	I	—	Rear Axle Differential Lock Indicator Control	52	0.35	YE	7115	III	—
53	0.35	YE / GN	7122	I	—	Axle Differential Lock Switch Signal	53	0.35	YE / GN	7122	III	—
54	0.5	GN / VT	5199	I	—	Run/Crank Relay Coil Control	54	0.5	GN / VT	5199	III	—
55 - 59	—	—	—	—	—	Not Occupied	55 - 59	—	—	—	—	—
60	0.35	YE / WH	1690	I	—	Mirror Dimming Signal	60	0.35	YE / WH	1690	III	—
61	0.35	BK / YE	1691	I	—	Automatic Day/Night Mirror Low Reference	61	0.35	BK / YE	1691	III	—
62 - 76	—	—	—	—	—	Not Occupied	62 - 76	—	—	—	—	—

## X213A Trailer Wiring Harness Extension Harness to Instrument Panel Wiring Harness

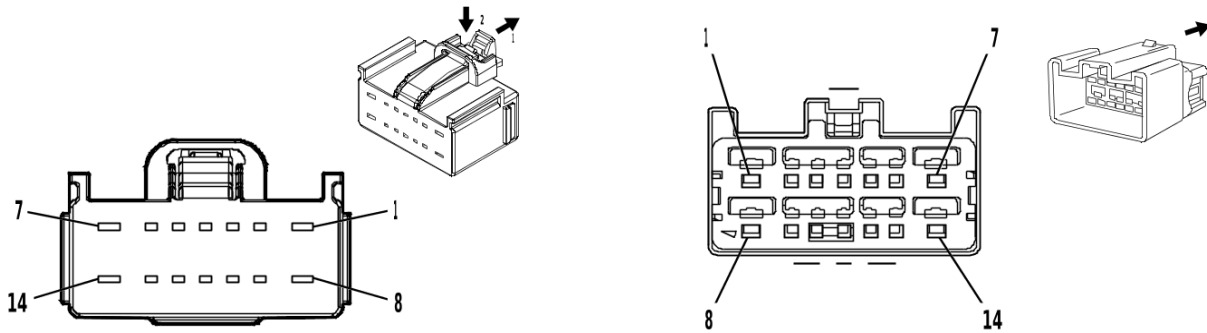

4934172

1283905

### Connector Part Information

Harness Type: Trailer Wiring Harness Extension Harness  
 OEM Connector: 13513605  
 Service Connector: Service by Harness - See Part Catalog  
 Description: 14-Way F 1.5, 2.8 YESC Series( GY)

### Connector Part Information

Harness Type: Instrument Panel Wiring Harness  
 OEM Connector: 7282-6447-40  
 Service Connector: 88956523  
 Description: 14-Way M 1.5, 2.8 YESC Series( L-GY)

### Terminal Part Information

Terminal Type ID	Terminated Lead	Diagnostic Test Probe	Terminal Removal Tool
I	Not required	J-35616-2A (GY)	No Tool Required
II	Not required	J-35616-4A (PU)	No Tool Required
III	13578907	J-35616-3 (GY)	J-38125-215A
IV	13578908	J-35616-5 (PU)	J-38125-11A

### X213A Trailer Wiring Harness Extension Harness to Instrument Panel Wiring Harness

Pin	Size	Color	Circuit	Terminal Type ID	Option	Function	Pin	Size	Color	Circuit	Terminal Type ID	Option
1	2.5	WH	22	II	—	Trailer Ground	1	2.5	WH	22	IV	—
2	—	—	—	—	—	Not Occupied	2	—	—	—	—	—
3	—	—	—	—	—	LED Backlight Dimming Control 1	3	0.35	YE	6817	III	—
4	—	—	—	—	—	Not Occupied	4	—	—	—	—	—
5	0.5	WH / BU	3691	I	—	Trailer Brake Apply Signal	5	0.35	WH / BU	3691	III	—
6	—	—	—	—	—	Not Occupied	6	—	—	—	—	—
7	2.5	RD / BN	4142	II	—	Primary Fused Battery Positive Voltage	7	2.5	RD / BN	4142	IV	—
8	—	—	—	—	—	Upfitter Accessory 5 Supply Voltage	8	2.5	VT / BU	10735	IV	—



**X213A Trailer Wiring Harness Extension Harness to Instrument Panel Wiring Harness  
(cont'd)**

Pin	Size	Color	Circuit	Terminal Type ID	Option	Function	Pin	Size	Color	Circuit	Terminal Type ID	Option
9	—	—	—	—	—	Out of Park Signal	9	0.35	YE	6812	III	—
10	—	—	—	—	—	Vehicle Speed Signal	10	0.35	GN / GY	817	III	—
11	—	—	—	—	—	Indicator Dimming Control	11	0.35	WH	6816	III	—
12	—	—	—	—	—	Not Occupied	12	—	—	—	—	—
13	—	—	—	—	—	Run/Crank Ignition 1 Voltage	13	0.5	VT / BK	339	III	—
14	2	BU	47	II	—	Trailer Auxiliary Control	14	2	BU	47	IV	—

**X213B Trailer Wiring Harness Extension Harness to Instrument Panel Wiring Harness**

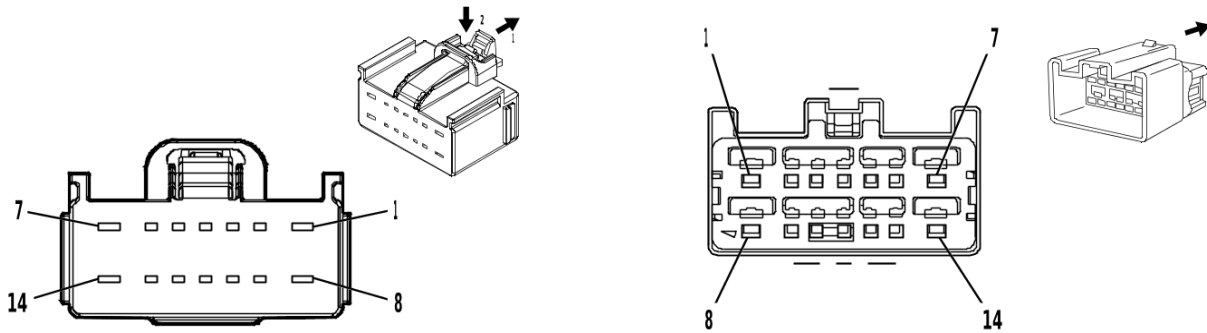

4934172

1283905

**Connector Part Information**

Harness Type: Trailer Wiring Harness Extension Harness  
 OEM Connector: 13513605  
 Service Connector: Service by Harness - See Part Catalog  
 Description: 14-Way F 1.5, 2.8 YESC Series( GY)

**Connector Part Information**

Harness Type: Instrument Panel Wiring Harness  
 OEM Connector: 7282-6447-40  
 Service Connector: 88956523  
 Description: 14-Way M 1.5, 2.8 YESC Series( L-GY)

**Terminal Part Information**

Terminal Type ID	Terminated Lead	Diagnostic Test Probe	Terminal Removal Tool
I	Not required	J-35616-2A (GY)	No Tool Required
II	Not required	J-35616-4A (PU)	No Tool Required
III	13578907	J-35616-3 (GY)	J-38125-215A
IV	13578908	J-35616-5 (PU)	J-38125-11A

**X213B Trailer Wiring Harness Extension Harness to Instrument Panel Wiring Harness**

Pin	Size	Color	Circuit	Terminal Type ID	Option	Function	Pin	Size	Color	Circuit	Terminal Type ID	Option
1	2.5	WH	22	II	—	Trailer Ground	1	2.5	WH	22	IV	—
2	—	—	—	—	—	Not Occupied	2	—	—	—	—	—
3	—	—	—	—	—	LED Backlight Dimming Control 1	3	0.35	YE	6817	III	—
4	—	—	—	—	—	Not Occupied	4	—	—	—	—	—
5	0.5	WH / BU	3691	I	—	Trailer Brake Apply Signal	5	0.35	WH / BU	3691	III	—
6	—	—	—	—	—	Not Occupied	6	—	—	—	—	—
7	2.5	RD / BN	4142	II	—	Primary Fused Battery Positive Voltage	7	2.5	RD / BN	4142	IV	—
8-13	—	—	—	—	—	Not Occupied	8-13	—	—	—	—	—
14	2	BU	47	II	—	Trailer Auxiliary Control	14	2	BU	47	IV	—

## X217 Body Wiring Harness to Instrument Panel Wiring Harness

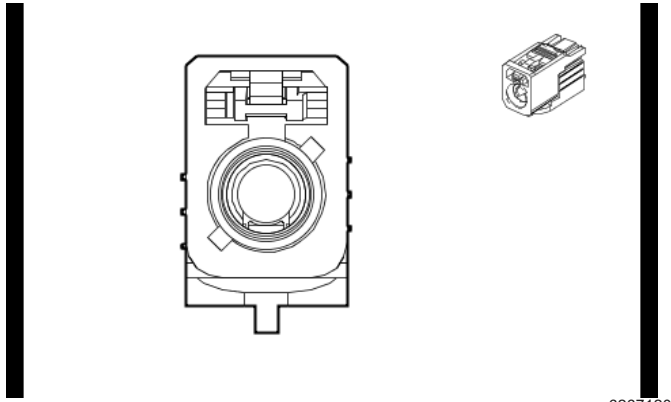

6267120

### Connector Part Information

Harness Type: Body Wiring Harness COAX  
 OEM Connector: 33351013  
 Service Connector: Service by Cable Assembly — See Part Catalog  
 Description: 1-Way F Coax Type( BU)

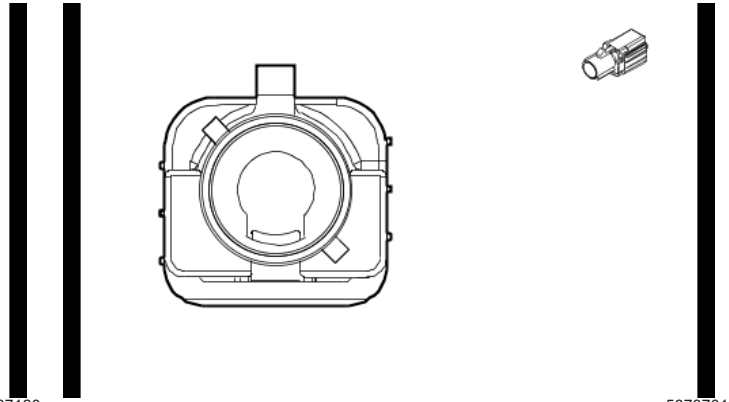

5873701

### Connector Part Information

Harness Type: Instrument Panel Wiring Harness COAX  
 OEM Connector: 33351038  
 Service Connector: Service by Cable Assembly — See Part Catalog  
 Description: 1-Way M Coax Type( BU)

### Terminal Part Information

Terminal Type ID	Terminated Lead	Diagnostic Test Probe	Terminal Removal Tool
I	Not required	No Tool Required	No Tool Required

### X217 Body Wiring Harness to Instrument Panel Wiring Harness

Pin	Size	Color	Circuit	Terminal Type ID	Option	Function	Pin	Size	Color	Circuit	Terminal Type ID	Option
—	—	Coax Cable	—	I	—	Video Processing Module Coaxial Video Signal	—	—	Coax Cable	—	I	—

**X218 Instrument Panel Wiring Harness to Body Wiring Harness**

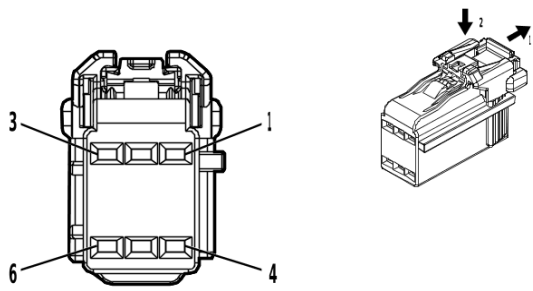

4862126

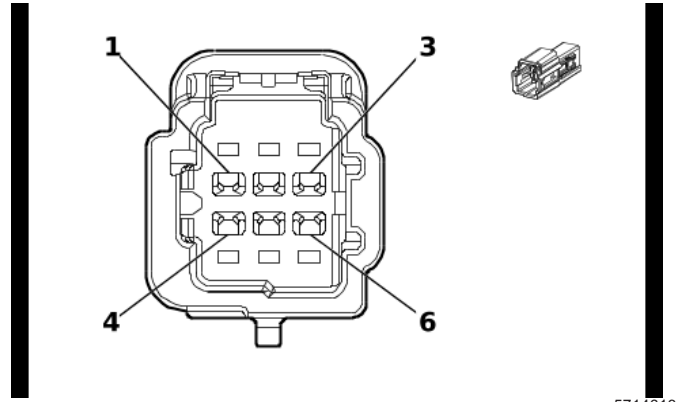

5714613

**Connector Part Information**

Harness Type: Instrument Panel Wiring Harness  
 OEM Connector: 6098-8996  
 Service Connector: 84613129  
 Description: 6-Way F 1.2 Series( BK)

**Connector Part Information**

Harness Type: Body Wiring Harness  
 OEM Connector: 6098-9120  
 Service Connector: 86825467  
 Description: 6-Way M 1.2 MBS Series( BK)

**Terminal Part Information**

Terminal Type ID	Terminated Lead	Diagnostic Test Probe	Terminal Removal Tool
I	Service by Cable	No Tool Required	No Tool Required
II	Service by Cable	No Tool Required	No Tool Required

**X218 Instrument Panel Wiring Harness to Body Wiring Harness**

Pin	Size	Color	Circuit	Terminal Type ID	Option	Function	Pin	Size	Color	Circuit	Terminal Type ID	Option
1	0.35	GN	7214	I	—	Ethernet Bus 6 [-]	1	0.35	GN	7214	II	—
2	0.35	YE	7215	I	—	Ethernet Bus 6 [+]	2	0.35	YE	7215	II	—
3-4	—	—	—	—	—	Not Occupied	3-4	—	—	—	—	—
5	0.35	BU	7224	I	—	Ethernet Bus 11 [-]	5	0.35	BU	7224	II	—
6	0.35	WH	7225	I	—	Ethernet Bus 11 [+]	6	0.35	WH	7225	II	—

**X219 Police Accessory Harness to Instrument Panel Wiring Harness (5W4 / 9C1)**

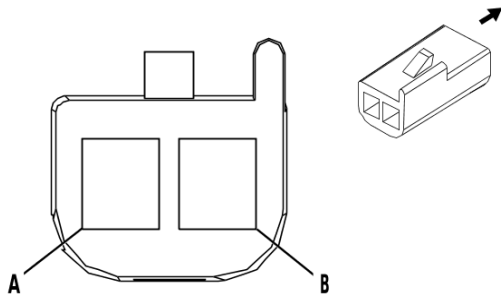

82383

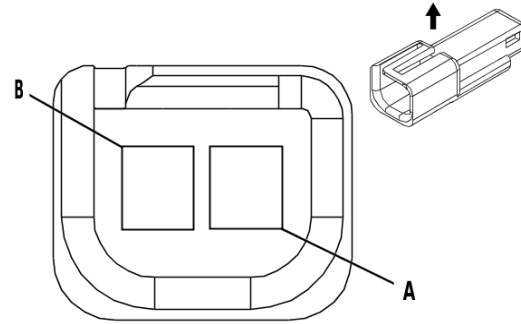

35441

**Connector Part Information**

Harness Type: Police Accessory Harness  
 OEM Connector: Not Available  
 Service Connector: Service by Harness - See Part Catalog  
 Description: 2-Way F

**Connector Part Information**

Harness Type: Instrument Panel Wiring Harness  
 OEM Connector: 12047663  
 Service Connector: 13584278  
 Description: 2-Way M 150 Metri-Pack Series( BK)

**Terminal Part Information**

Terminal Type ID	Terminated Lead	Diagnostic Test Probe	Terminal Removal Tool
I	Not required	No Tool Required	No Tool Required
II	Not required	J-35616-3 (GY)	No Tool Required

**X219 Police Accessory Harness to Instrument Panel Wiring Harness (5W4 / 9C1)**

Pin	Size	Color	Circuit	Terminal Type ID	Option	Function	Pin	Size	Color	Circuit	Terminal Type ID	Option
A	0.75	BK	1050	I	—	Ground	A	0.75	BK	1050	II	—
B	0.75	RD / GY	10340	I	—	Battery Positive Voltage Police	B	0.75	RD / GY	10340	II	—

**X220 Police Accessory Harness to Instrument Panel Wiring Harness (5W4 / 9C1)**

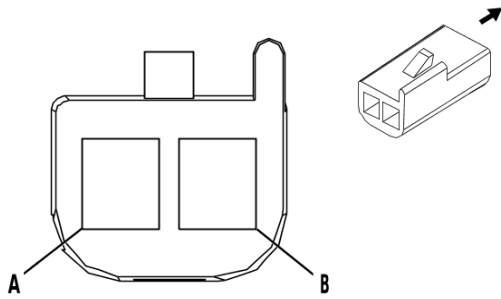

82383

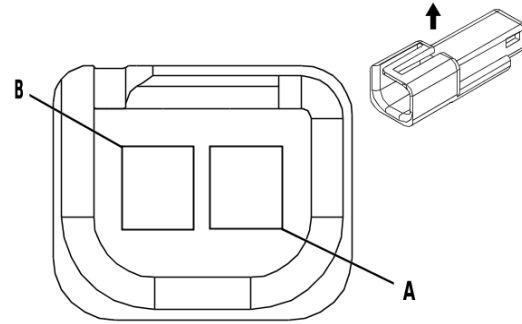

35441

**Connector Part Information**

Harness Type: Police Accessory Harness  
 OEM Connector: Not Available  
 Service Connector: Service by Harness - See Part Catalog  
 Description: 2-Way F

**Connector Part Information**

Harness Type: Instrument Panel Wiring Harness  
 OEM Connector: 12047663  
 Service Connector: 13584278  
 Description: 2-Way M 150 Metri-Pack Series( BK)

**Terminal Part Information**

Terminal Type ID	Terminated Lead	Diagnostic Test Probe	Terminal Removal Tool
I	Not required	No Tool Required	No Tool Required
II	Not required	J-35616-3 (GY)	No Tool Required

**X220 Police Accessory Harness to Instrument Panel Wiring Harness (5W4 / 9C1)**

Pin	Size	Color	Circuit	Terminal Type ID	Option	Function	Pin	Size	Color	Circuit	Terminal Type ID	Option
A	0.75	BK	1050	I	—	Ground	A	0.75	BK	1050	II	—
B	0.75	RD / GN	10240	I	—	Battery Positive Voltage Police	B	0.75	RD / GN	10240	II	—

## X225 Front Floor Console Wiring Harness to Body Wiring Harness

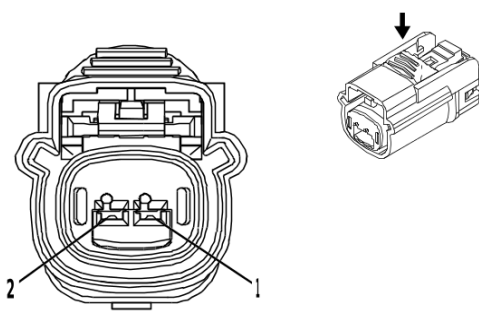

4332222

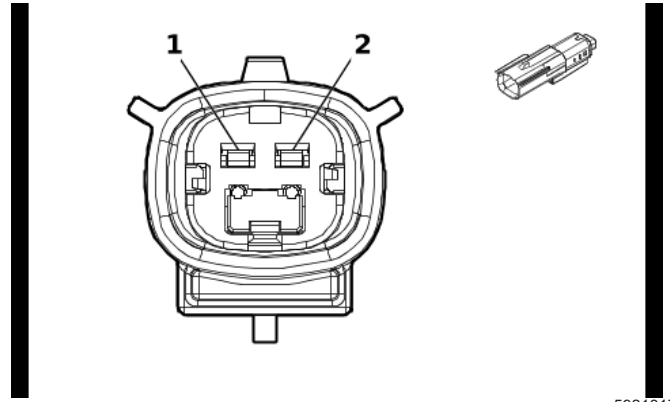

5921817

### Connector Part Information

Harness Type: Front Floor Console Wiring Harness  
 OEM Connector: 15514573  
 Service Connector: Service by Harness - See Part Catalog  
 Description: 2-Way F 1.5 OCS Series, Sealed( BK)

### Connector Part Information

Harness Type: Body Wiring Harness  
 OEM Connector: 15514550  
 Service Connector: 86825463  
 Description: 2-Way M 1.5 OCS Series, Sealed( BK)

### Terminal Part Information

Terminal Type ID	Terminated Lead	Diagnostic Test Probe	Terminal Removal Tool
I	Service by Cable	No Tool Required	No Tool Required
II	Service by Cable	No Tool Required	No Tool Required

### X225 Front Floor Console Wiring Harness to Body Wiring Harness

Pin	Size	Color	Circuit	Terminal Type ID	Option	Function	Pin	Size	Color	Circuit	Terminal Type ID	Option
1	0.35	BU	7224	I	—	Ethernet Bus 11 [-]	1	0.35	BU	7224	II	—
2	0.35	WH	7225	I	—	Ethernet Bus 11 [+]	2	0.35	WH	7225	II	—

**X226 Front Floor Console Wiring Harness to Instrument Panel Wiring Harness**

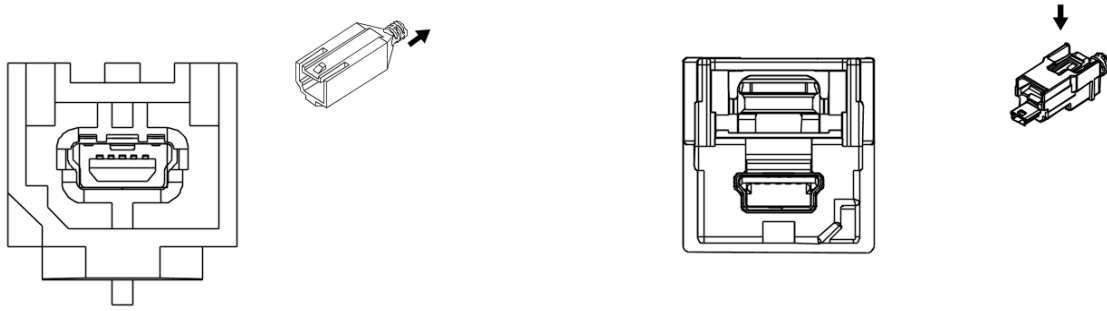

3273655

2807425

**Connector Part Information**

Harness Type: Front Floor Console Wiring Harness USB  
 OEM Connector: 13699757  
 Service Connector: Service by Cable Assembly — See Part Catalog  
 Description: 5-Way F 2.0 Mini-B USB Type( BK)

**Connector Part Information**

Harness Type: Instrument Panel Wiring Harness USB  
 OEM Connector: 13576672  
 Service Connector: Service by Cable Assembly — See Part Catalog  
 Description: 5-Way M 2.0 Mini-B USB Type( BK)

**Terminal Part Information**

Terminal Type ID	Terminated Lead	Diagnostic Test Probe	Terminal Removal Tool
I	Not required	No Tool Required	No Tool Required

**X226 Front Floor Console Wiring Harness to Instrument Panel Wiring Harness**

Pin	Size	Color	Circuit	Terminal Type ID	Option	Function	Pin	Size	Color	Circuit	Terminal Type ID	Option
—	—	USB	—	I	—	USB Serial Data	—	—	USB	—	I	—



**X227 Front Floor Console Wiring Harness to Body Wiring Harness - Double Cab / Crew Cab**

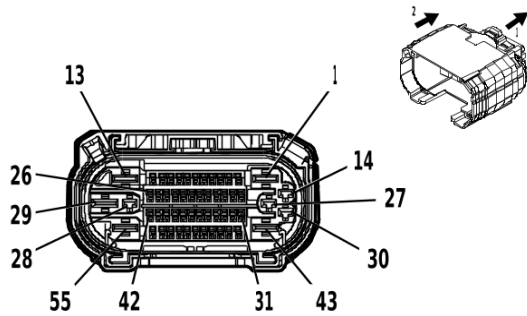

4992168

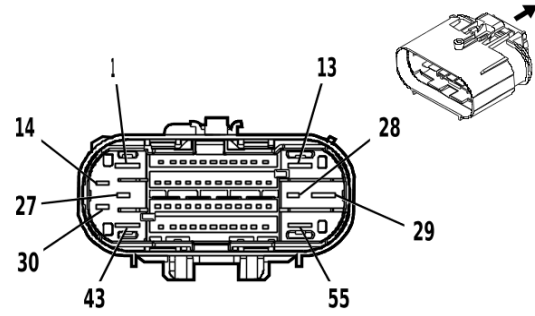

4993301

**Connector Part Information**

Harness Type: Front Floor Console Wiring Harness  
 OEM Connector: 35598969  
 Service Connector: Service by Harness - See Part Catalog  
 Description: 55-Way F 1.2 OCS, 2.8, 6.3 CTS Series, Sealed( BK)

**Connector Part Information**

Harness Type: Body Wiring Harness  
 OEM Connector: 35589922  
 Service Connector: 84727364  
 Description: 55-Way M 1.2 OCS, 2.8, 6.3 CTS Series, Sealed( BK)

**Terminal Part Information**

Terminal Type ID	Terminated Lead	Diagnostic Test Probe	Terminal Removal Tool
I	Not required	J-35616-12 (BU)	No Tool Required
II	Not required	J-35616-16 (L-GN)	No Tool Required
III	Not required	J-35616-35 (VT)	No Tool Required
IV	Not required	J-35616-42 (RD)	No Tool Required
V	84847992	J-35616-32 (OG)	J-38125-36
VI	84867140	J-35616-13 (BU)	J-38125-215A
VII	84992391	J-35616-5 (PU)	J-38125-215A

**X227 Front Floor Console Wiring Harness to Body Wiring Harness - Double Cab / Crew Cab**

Pin	Size	Color	Circuit	Terminal Type ID	Option	Function	Pin	Size	Color	Circuit	Terminal Type ID	Option
1 - 2	—	—	—	—	—	Not Occu- pied	1 - 2	—	—	—	—	—
3	0.35	WH	4986	I	—	AUTOSAR CAN Bus [-] 1 Serial Data	3	0.35	WH	4986	VI	—
4	0.35	BU	4987	I	—	AUTOSAR CAN Bus [+] 1 Serial Data	4	0.35	BU	4987	VI	—
5	0.35	VT / WH	239	I	—	Run/Crank Ignition 1 Voltage	5	0.5	VT / WH	239	VI	—
6	0.35	WH	4986	I	—	AUTOSAR CAN Bus [-] 1 Serial Data	6	0.5	WH	4986	VI	—
7	0.35	BU	4987	I	—	AUTOSAR CAN Bus [+] 1 Serial Data	7	0.5	BU	4987	VI	—

**6-812 Electrical Component and Inline Harness Connector End Views**

**X227 Front Floor Console Wiring Harness to Body Wiring Harness - Double Cab / Crew Cab (cont'd)**

Pin	Size	Color	Circuit	Terminal Type ID	Option	Function	Pin	Size	Color	Circuit	Terminal Type ID	Option
8	0.35	RD / WH	5440	I	—	Battery Positive Voltage	8	0.5	RD / WH	5440	VI	—
9	0.5	RD / BU	1240	II	—	Battery Positive Voltage	9	0.5	RD / BU	1240	VI	—
10	0.35	BN / BK	3552	I	—	Interior Passive Entry Antenna 1 High Signal	10	0.35	BN / BK	3552	VI	—
11	0.35	WH	3553	I	—	Interior Passive Entry Antenna 1 Low Signal	11	0.35	WH	3553	VI	—
12 - 13	—	—	—	—	—	Not Occupied	12 - 13	—	—	—	—	—
14	0.75	BK	10117	III	—	AC Outlet Phase A Control	14	0.75	BK	10117	VII	—
15	0.35	RD / WH	4740	I	—	Battery Positive Voltage	15	0.5	RD / WH	4740	VI	—
16	0.35	YE	4976	I	—	AUTOSAR CAN Bus [-] 3 Serial Data	16	0.5	WH	4976	VI	—
17	0.35	BU / BK	4977	I	—	AUTOSAR CAN Bus [+] 3 Serial Data	17	0.5	BU / BK	4977	VI	—
18	0.35	YE	4976	I	—	AUTOSAR CAN Bus [-] 3 Serial Data	18	0.5	WH	4976	VI	—
19	0.35	BU / BK	4977	I	—	AUTOSAR CAN Bus [+] 3 Serial Data	19	0.5	BU / BK	4977	VI	—
20	0.35	WH	4978	I	UGN-UKL UKL	AUTOSAR CAN Bus [-] 2 Serial Data	20	0.35	WH	4978	VI	—
	0.35	YE	4978	I		AUTOSAR CAN Bus [-] 2 Serial Data						
21	0.35	BU / YE	4979	I	—	AUTOSAR CAN Bus [+] 2 Serial Data	21	0.35	BU / YE	4979	VI	—
22	0.5	BU / YE	4984	II	—	AUTOSAR CAN Bus [-] 5 Serial Data	22	0.5	BU / YE	4984	VI	—
23	0.5	BU / WH	4985	II	—	AUTOSAR CAN Bus [+] 5 Serial Data	23	0.5	BU / WH	4985	VI	—
24	0.5	BU / YE	4984	II	—	AUTOSAR CAN Bus [-] 5 Serial Data	24	0.5	BU / YE	4984	VI	—
25	0.5	BU / WH	4985	II	—	AUTOSAR CAN Bus [+] 5 Serial Data	25	0.5	BU / WH	4985	VI	—
26	0.5	BK	1350	II	—	Ground	26	0.75	BK	1350	VI	—
27	0.5	WH	10116	III	—	AC Outlet Low Reference	27	0.5	WH	10116	VII	—

**X227 Front Floor Console Wiring Harness to Body Wiring Harness - Double Cab / Crew Cab (cont'd)**

Pin	Size	Color	Circuit	Terminal Type ID	Option	Function	Pin	Size	Color	Circuit	Terminal Type ID	Option
28	0.35	GN / BU	2733	III	—	Brake System Control Module LIN Bus 2	28	0.5	GN / BU	2733	VII	—
29	0.5	RD / VT	2640	IV	—	Battery Positive Voltage	29	0.5	RD / VT	2640	V	—
30	0.75	RD	10118	III	—	AC Outlet Phase B Control	30	0.75	RD	10118	VII	—
31	0.35	VT / GY	8978	I	—	Inertial Sensor Supply Voltage	31	0.5	VT / GY	8978	VI	—
32	0.35	BN / BK	4996	I	—	Immobilizer Antenna Signal [+]	32	0.35	BN / BK	4996	VI	—
33	0.35	WH / GY	4997	I	—	Immobilizer Antenna Low Signal	33	0.35	WH / GY	4997	VI	—
34	0.35	WH / YE	8976	I	—	Private Serial Data Active Safety CAN Bus [-] Serial Data	34	0.5	WH / YE	8976	VI	—
35	0.35	BU / YE	8977	I	—	Private Serial Data Active Safety CAN Bus [+] Serial Data	35	0.5	BU / YE	8977	VI	—
36	0.5	RD / YE	2340	II	—	Battery Positive Voltage	36	0.5	RD / YE	2340	VI	—
37	0.5	GN / VT	2857	II	—	Body Control Module LIN Bus 11	37	0.35	GN / VT	2857	VI	—
38	0.5	VT / RD	4049	II	—	AC Power Outlet Sensor High Reference	38	0.5	VT / RD	4049	VI	—
39	0.35	VT / GN	4320	I	—	Powertrain Sensor Bus Enable	39	0.5	VT / GN	4320	VI	—
40	0.35	WH	4055	I	—	Private Serial Data Powertrain CAN Bus [+] Serial Data	40	0.5	WH	4055	VI	—
41	0.35	GN / GY	4627	I	—	Image Processing Module LIN Bus 1	41	0.5	GN / GY	4627	VI	—
42	0.5	BU / BN	6807	II	—	DC/AC Inverter Control	42	0.5	BU / BN	6807	VI	—
43	0.5	GN / VT	4786	IV	—	Dome/Reading Lamp Enable Signal	43	0.5	GN / VT	4786	V	—
44	0.75	YE	6817	II	—	LED Backlight Dimming Control 1	44	0.75	YE	6817	VI	—

**6-814 Electrical Component and Inline Harness Connector End Views**

**X227 Front Floor Console Wiring Harness to Body Wiring Harness - Double Cab / Crew Cab (cont'd)**

Pin	Size	Color	Circuit	Terminal Type ID	Option	Function	Pin	Size	Color	Circuit	Terminal Type ID	Option
45	0.35	BU / GY	4054	I	—	Private Serial Data Powertrain CAN Bus [-] Serial Data	45	0.5	BU / GY	4054	VI	—
46	0.35	WH	4055	I	—	Private Serial Data Powertrain CAN Bus [+] Serial Data	46	0.5	WH	4055	VI	—
47	0.5	BK	1451	II	—	Signal Ground	47	0.75	BK / WH	1451	VI	—
48	0.35	VT	4701	I	—	Retained Accessory Power Control	48	0.35	VT	4701	VI	—
49	0.35	WH / GY	4104	I	—	AUTOSAR CAN Bus [-] 8 Serial Data	49	0.5	WH / GY	4104	VI	—
50	0.35	BU / GY	4105	I	—	AUTOSAR CAN Bus [+] 8 Serial Data	50	0.5	BU / GY	4105	VI	—
51	0.5	BK / WH	1451	II	—	Signal Ground	51	0.75	BK / WH	1451	VI	—
52	0.5	BK / WH	1051	II	—	Signal Ground	52	0.5	BK / WH	1051	VI	—
53	0.35	BU / GY	4054	I	—	Private Serial Data Powertrain CAN Bus [-] Serial Data	53	0.5	BU / GY	4054	VI	—
54 - 55	—	—	—	—	—	Not Occupied	54 - 55	—	—	—	—	—

**X227 Front Seat Wiring Harness - Center to Body Wiring Harness - Regular Cab**

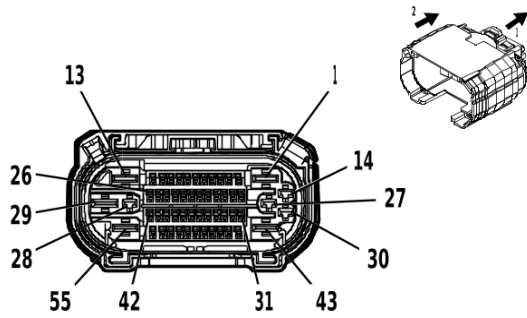

4992168

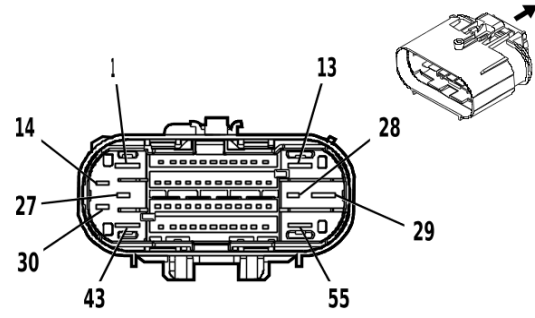

4993301

**Connector Part Information**

Harness Type: Front Seat Wiring Harness - Center  
 OEM Connector: 35016652  
 Service Connector: Service by Harness - See Part Catalog  
 Description: 55-Way F 1.2 OCS, 2.8, 6.3 CTS Series, Sealed( BK)

**Connector Part Information**

Harness Type: Body Wiring Harness  
 OEM Connector: 35589924  
 Service Connector: 84727364  
 Description: 55-Way M 1.2 OCS, 2.8, 6.3 CTS Series, Sealed( BK)

**Terminal Part Information**

Terminal Type ID	Terminated Lead	Diagnostic Test Probe	Terminal Removal Tool
I	Not required	J-35616-16 (L-GN)	No Tool Required
II	Not required	J-35616-35 (VT)	No Tool Required
III	Not required	No Tool Required	No Tool Required
IV	84847992	J-35616-32 (OG)	J-38125-36
V	84867140	J-35616-13 (BU)	J-38125-215A
VI	84992391	J-35616-5 (PU)	J-38125-215A

**X227 Front Seat Wiring Harness - Center to Body Wiring Harness - Regular Cab**

Pin	Size	Color	Circuit	Terminal Type ID	Option	Function	Pin	Size	Color	Circuit	Terminal Type ID	Option
1-4	—	—	—	—	—	Not Occupied	1-4	—	—	—	—	—
5	0.5	VT / WH	239	I	—	Run/Crank Ignition 1 Voltage	5	0.5	VT / WH	239	V	—
6-7	—	—	—	—	—	Not Occupied	6-7	—	—	—	—	—
8	0.5	RD / WH	5440	I	—	Battery Positive Voltage	8	0.5	RD / WH	5440	V	—
9	—	—	—	—	—	Not Occupied	9	—	—	—	—	—
10	0.35	BN / BK	3552	I	—	Interior Passive Entry Antenna 1 High Signal	10	0.35	BN / BK	3552	V	—
11	0.35	WH	3553	I	—	Interior Passive Entry Antenna 1 Low Signal	11	0.35	WH	3553	V	—

**6-816 Electrical Component and Inline Harness Connector End Views**

**X227 Front Seat Wiring Harness - Center to Body Wiring Harness - Regular Cab (cont'd)**

Pin	Size	Color	Circuit	Terminal Type ID	Option	Function	Pin	Size	Color	Circuit	Terminal Type ID	Option
12 - 13	—	—	—	—	—	Not Occupied	12 - 13	—	—	—	—	—
14	0.75	BK	10117	II	—	AC Outlet Phase A Control	14	0.75	BK	10117	VI	—
15	—	—	—	—	—	Not Occupied	15	—	—	—	—	—
16	0.35	WH	4976	I	—	AUTOSAR CAN Bus [-] 3 Serial Data	16	0.5	WH	4976	V	—
17	0.35	BU / BK	4977	I	—	AUTOSAR CAN Bus [+] 3 Serial Data	17	0.5	BU / BK	4977	V	—
18	0.35	WH	4976	I	—	AUTOSAR CAN Bus [-] 3 Serial Data	18	0.5	WH	4976	V	—
19	0.35	BU / BK	4977	I	—	AUTOSAR CAN Bus [+] 3 Serial Data	19	0.5	BU / BK	4977	V	—
20 - 21	—	—	—	—	—	Not Occupied	20 - 21	—	—	—	—	—
22	0.5	BU / YE	4984	I	—	AUTOSAR CAN Bus [-] 5 Serial Data	22	0.5	BU / YE	4984	V	—
23	0.5	BU / WH	4985	I	—	AUTOSAR CAN Bus [+] 5 Serial Data	23	0.5	BU / WH	4985	V	—
24	0.5	BU / YE	4984	I	—	AUTOSAR CAN Bus [-] 5 Serial Data	24	0.5	BU / YE	4984	V	—
25	0.5	BU / WH	4985	I	—	AUTOSAR CAN Bus [+] 5 Serial Data	25	0.5	BU / WH	4985	V	—
26	0.75	BK	1050	I	—	Ground	26	0.75	BK	1350	V	—
27	0.35	BK	10116	II	—	AC Outlet Low Reference	27	0.5	WH	10116	VI	—
28	0.5	GN / D/BU	2733	II	—	Brake System Control Module LIN Bus 2	28	0.5	GN / BU	2733	VI	—
29	0.5	RD / VT	2640	III	—	Battery Positive Voltage	29	0.5	RD / VT	2640	IV	—
30	0.75	RD	10118	II	—	AC Outlet Phase B Control	30	0.75	RD	10118	VI	—
31	—	—	—	—	—	Not Occupied	31	—	—	—	—	—
32	0.5	BN / BK	4996	I	—	Immobilizer Antenna Signal [+]	32	0.35	BN / BK	4996	V	—
33	0.5	WH / GY	4997	I	—	Immobilizer Antenna Low Signal	33	0.35	WH / GY	4997	V	—
34 - 35	—	—	—	—	—	Not Occupied	34 - 35	—	—	—	—	—

**X227 Front Seat Wiring Harness - Center to Body Wiring Harness - Regular Cab (cont'd)**

Pin	Size	Color	Circuit	Terminal Type ID	Option	Function	Pin	Size	Color	Circuit	Terminal Type ID	Option
36	0.5	RD / YE	2340	I	—	Battery Positive Voltage	36	0.5	RD / YE	2340	V	—
37	—	—	—	—	—	Not Occupied	37	—	—	—	—	—
38	0.75	VT / RD	4049	I	—	AC Power Outlet Sensor High Reference	38	0.5	VT / RD	4049	V	—
39	0.5	VT / GN	4320	I	—	Powertrain Sensor Bus Enable	39	0.5	VT / GN	4320	V	—
40	0.35	WH	4055	I	—	Private Serial Data Powertrain CAN Bus [+] Serial Data	40	0.5	WH	4055	V	—
41	—	—	—	—	—	Not Occupied	41	—	—	—	—	—
42	0.75	BU / BN	6807	I	—	DC/AC Inverter Control	42	0.5	BU / BN	6807	V	—
43	0.5	GN / VT	4786	I	—	Dome/Reading Lamp Enable Signal	43	0.5	GN / VT	4786	IV	—
44	0.75 0.75	YE BK	6817 6817	I I	— —	LED Backlight Dimming Control 1 LED Backlight Dimming Control 1	44	0.75	YE	6817	V	—
45	0.35	BU / GY	4054	I	—	Private Serial Data Powertrain CAN Bus [-] Serial Data	45	0.5	BU / GY	4054	V	—
46	0.35	WH	4055	I	—	Private Serial Data Powertrain CAN Bus [+] Serial Data	46	0.5	WH	4055	V	—
47	0.35	BK	1350	I	—	Ground	47	0.75	BK / WH	1451	V	—
48	0.35	VT	4701	I	—	Retained Accessory Power Control	48	0.35	VT	4701	V	—
49 - 51	—	—	—	—	—	Not Occupied	49 - 51	—	—	—	—	—
52	0.5	BK / WH	1051	I	—	Signal Ground	52	0.5	BK / WH	1051	V	—
53	0.35	BU / GY	4054	I	—	Private Serial Data Powertrain CAN Bus [-] Serial Data	53	0.5	BU / GY	4054	V	—
54 - 55	—	—	—	—	—	Not Occupied	54 - 55	—	—	—	—	—

**X237 Instrument Panel Wiring Harness to Instrument Panel Airbag Wiring Harness**

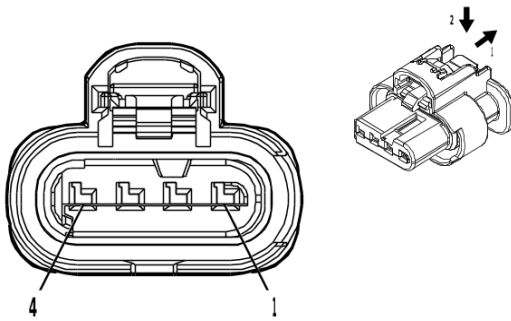

4900699

**Connector Part Information**

Harness Type: Instrument Panel Wiring Harness  
 OEM Connector: 2296700-3  
 Service Connector: 19371193  
 Description: 4-Way F 1.2 MCON-CB Series, Sealed( YE)

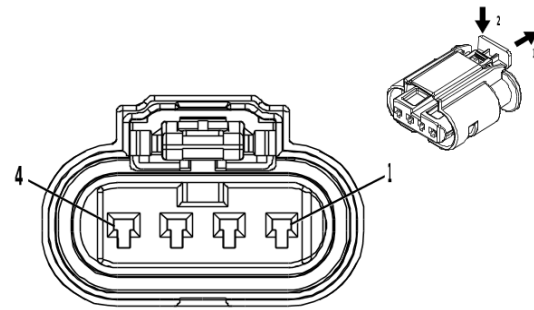

4256222

**Connector Part Information**

Harness Type: Instrument Panel Airbag Wiring Harness  
 OEM Connector: Not Available  
 Service Connector: Service by Harness - See Part Catalog  
 Description: 4-Way M ( YE)

**Terminal Part Information**

Terminal Type ID	Terminated Lead	Diagnostic Test Probe	Terminal Removal Tool
I	Not required	J-35616-16 (L-GN)	No Tool Required
II	Not required	No Tool Required	No Tool Required

**X237 Instrument Panel Wiring Harness to Instrument Panel Airbag Wiring Harness**

Pin	Size	Color	Circuit	Terminal Type ID	Option	Function	Pin	Size	Color	Circuit	Terminal Type ID	Option
1	0.35	YE / OG	3025	I	—	Passenger Instrument Panel Air Bag Stage 1 High Control	1	0.35	YE / OG	3025	II	—
2	0.35	OG / WH	3024	I	—	Passenger Instrument Panel Air Bag Stage 1 Low Control	2	0.35	OG / WH	3024	II	—
3	0.35	GY / OG	3027	I	—	Passenger Instrument Panel Air Bag Stage 2 High Control	3	0.35	GY / OG	3027	II	—
4	0.35	OG / VT	3026	I	—	Passenger Instrument Panel Air Bag Stage 2 Low Control	4	0.35	OG / VT	3026	II	—



## X250 Instrument Panel Wiring Harness to Heater Wiring Harness

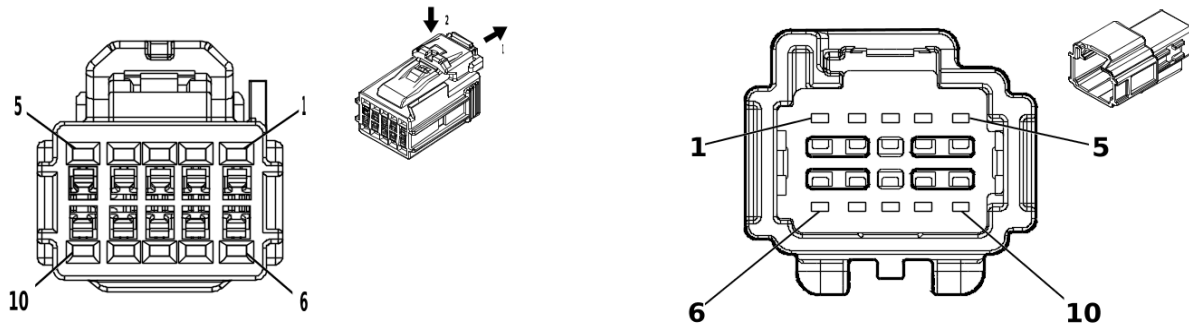

4254030

5355759

### Connector Part Information

Harness Type: Instrument Panel Wiring Harness  
 OEM Connector: 6098-9004  
 Service Connector: 13532428  
 Description: 10-Way F 1.2 Series( BK)

### Connector Part Information

Harness Type: Heater Wiring Harness  
 OEM Connector: Not Available  
 Service Connector: Service by Harness - See Part Catalog  
 Description: 10-Way M ( BK)

### Terminal Part Information

Terminal Type ID	Terminated Lead	Diagnostic Test Probe	Terminal Removal Tool
I	84962854	J-35616-12 (BU)	J-38125-215A
II	Not required	No Tool Required	No Tool Required

### X250 Instrument Panel Wiring Harness to Heater Wiring Harness

Pin	Size	Color	Circuit	Terminal Type ID	Option	Function	Pin	Size	Color	Circuit	Terminal Type ID	Option
1	—	—	—	—	—	Not Occu- pied	1	—	—	—	—	—
2	0.5	BK	1050	I	—	Ground	2	0.5	BK	1050	II	—
3- 4	—	—	—	—	—	Not Occu- pied	3- 4	—	—	—	—	—
5	0.35	GY	6137	I	—	Air Condi- tioning Evap- orator Tem- perature Sensor Sig- nal	5	0.35	GY	6137	II	—
6	0.35	GN / VT	2852	I	—	Body Control Module LIN Bus 6	6	0.35	GN / VT	2852	II	—
7	0.35	BK / YE	407	I	—	Sensor Low Reference	7	0.35	BK / YE	407	II	—
8	0.5	VT / BK	339	I	—	Run/Crank Ignition 1 Voltage	8	0.5	VT / BK	339	II	—
9	0.35	WH / YE	4634	I	—	HVAC Re- mote Enable Signal	9	0.35	WH / YE	4634	II	—
10	—	—	—	—	—	Not Occu- pied	10	—	—	—	—	—

**X251 HVAC Wiring Harness to Body Wiring Harness (C32)**

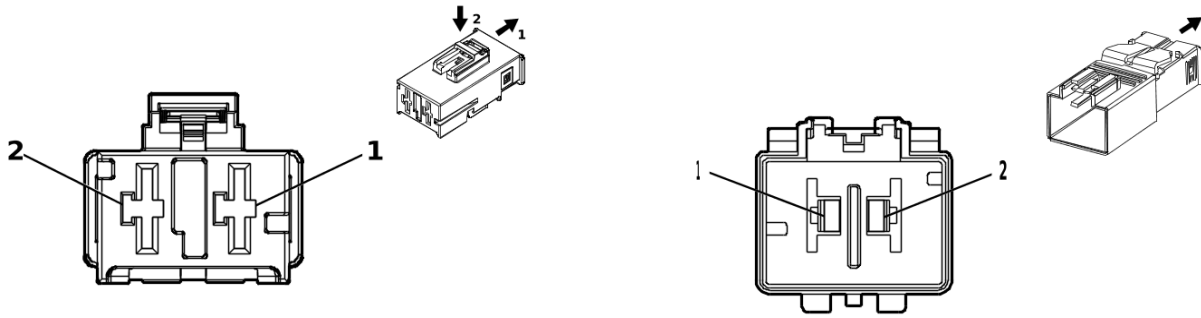

5187955

4891120

**Connector Part Information**

Harness Type: HVAC Wiring Harness  
 OEM Connector: Not Available  
 Service Connector: Service by Harness - See Part Catalog  
 Description: 2-Way F

**Connector Part Information**

Harness Type: Body Wiring Harness  
 OEM Connector: 2317373-1  
 Service Connector: Service by Harness - See Part Catalog  
 Description: 2-Way M 9.5 MCON-LL Series( BK)

**Terminal Part Information**

Terminal Type ID	Terminated Lead	Diagnostic Test Probe	Terminal Removal Tool
I	Not required	No Tool Required	No Tool Required
II	Not required	J-35616-21 (RD)	No Tool Required

**X251 HVAC Wiring Harness to Body Wiring Harness (C32)**

Pin	Size	Color	Circuit	Terminal Type ID	Option	Function	Pin	Size	Color	Circuit	Terminal Type ID	Option
1	—	—	—	—	—	Not Occupied	1	—	—	—	—	—
2	10	RD / GY	642	I	—	Battery Positive Voltage	2	10	RD / GY	642	II	—

**X309 Body Wiring Harness to Inside Rearview Mirror Wiring Harness - Jumper (UVN)**

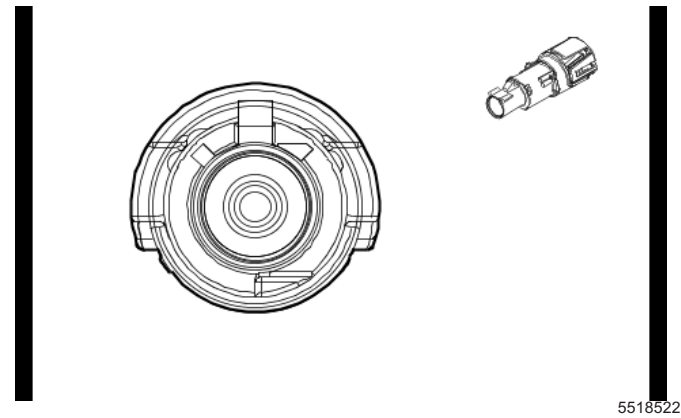
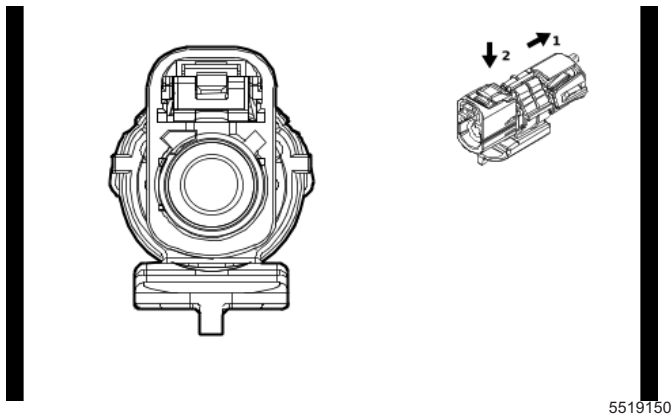

**Connector Part Information**

Harness Type: Body Wiring Harness COAX  
 OEM Connector: 35187047  
 Service Connector: Service by Cable Assembly — See Part Catalog  
 Description: 1-Way F Coax Type, Sealed( BK)

**Connector Part Information**

Harness Type: Inside Rearview Mirror Wiring Harness - Jumper COAX  
 OEM Connector: 33355538  
 Service Connector: Service by Cable Assembly — See Part Catalog  
 Description: 1-Way M Coax Type( BK)

**Terminal Part Information**

Terminal Type ID	Terminated Lead	Diagnostic Test Probe	Terminal Removal Tool
I	Not required	No Tool Required	No Tool Required

**X309 Body Wiring Harness to Inside Rearview Mirror Wiring Harness - Jumper (UVN)**

Pin	Size	Color	Circuit	Terminal Type ID	Option	Function	Pin	Size	Color	Circuit	Terminal Type ID	Option
—	—	Coax Cable	—	I	—	Cargo Bed Rear Vision Camera Co-axial Video Signal	—	—	Coax Cable	—	I	—

**X324 Body Wiring Harness to Body Rear Wiring Harness Extension Harness (KI5)**

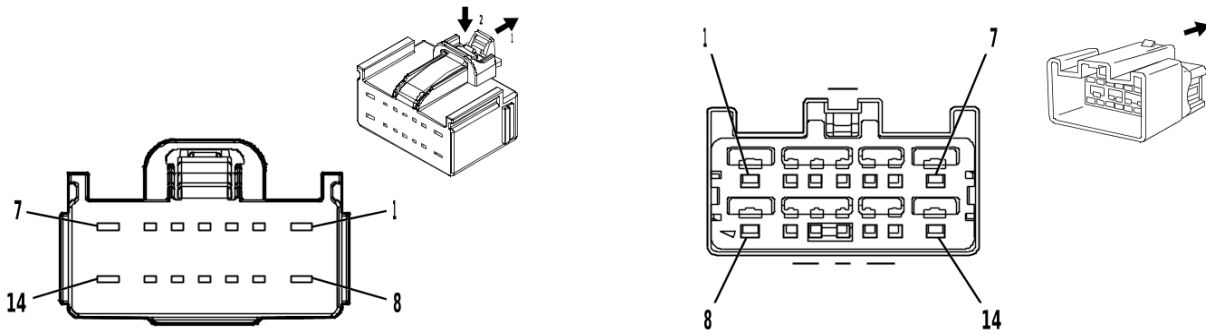

4934172

1283905

**Connector Part Information**

Harness Type: Body Wiring Harness  
 OEM Connector: 7289-7630-30  
 Service Connector: 13513604  
 Description: 14-Way F 1.5, 2.8 YESC Series( BK)

**Connector Part Information**

Harness Type: Body Rear Wiring Harness Extension Harness  
 OEM Connector: 7282-6447-40  
 Service Connector: Service by Harness - See Part Catalog  
 Description: 14-Way M 1.5, 2.8 YESC Series( L-GY)

**Terminal Part Information**

Terminal Type ID	Terminated Lead	Diagnostic Test Probe	Terminal Removal Tool
I	13575850	J-35616-2A (GY)	J-38125-557
II	84962855	J-35616-4A (PU)	J-38125-11A
III	Not required	J-35616-3 (GY)	No Tool Required
IV	Not required	J-35616-5 (PU)	No Tool Required

**X324 Body Wiring Harness to Body Rear Wiring Harness Extension Harness (KI5)**

Pin	Size	Color	Circuit	Terminal Type ID	Option	Function	Pin	Size	Color	Circuit	Terminal Type ID	Option
1	0.75	BK	10117	II	—	AC Outlet Phase A Control	1	0.75	BK	10117	IV	—
2	0.5	VT / RD	4049	I	—	AC Power Outlet Sensor High Reference	2	0.5	VT / RD	4049	III	—
3	0.35	VT / WH	239	I	—	Run/Crank Ignition 1 Voltage	3	0.35	VT / WH	239	III	—
4	0.5	WH / GN	4628	I	—	DC/AC Inverter Relay Control	4	0.5	WH / GN	4628	III	—
5	0.5	BU / BN	6807	I	—	DC/AC Inverter Control	5	0.5	BU / BN	6807	III	—
6	—	—	—	—	—	Not Occupied	6	—	—	—	—	—
7	0.75	BK / WH	10120	II	—	AC Outlet 2 Phase A Control	7	0.75	BK / WH	10120	IV	—
8	0.75	RD	10118	II	—	AC Outlet Phase B Control	8	0.75	RD	10118	IV	—

**X324 Body Wiring Harness to Body Rear Wiring Harness Extension Harness (K15) (cont'd)**

Pin	Size	Color	Circuit	Terminal Type ID	Option	Function	Pin	Size	Color	Circuit	Terminal Type ID	Option
9	0.35	Bare	10116	I	—	AC Outlet Low Reference	9	0.35	Bare	10116	III	—
10	0.35	GN / BU	6133	I	—	Body Control Module LIN Bus 2	10	0.5	GN / BU	6133	III	—
11	—	—	—	—	—	Not Occupied	11	—	—	—	—	—
12	0.5	GN / BN	2266	I	—	DC/AC Inverter Control 2	12	0.5	GN / BN	2266	III	—
13	0.35	Bare	10119	I	—	AC Outlet 2 Low Reference	13	0.35	Bare	10119	III	—
14	0.75	RD / WH	10121	II	—	AC Outlet 2 Phase B Control	14	0.75	RD / WH	10121	IV	—

X331 Front Seat Wiring Harness - Driver to Body Wiring Harness

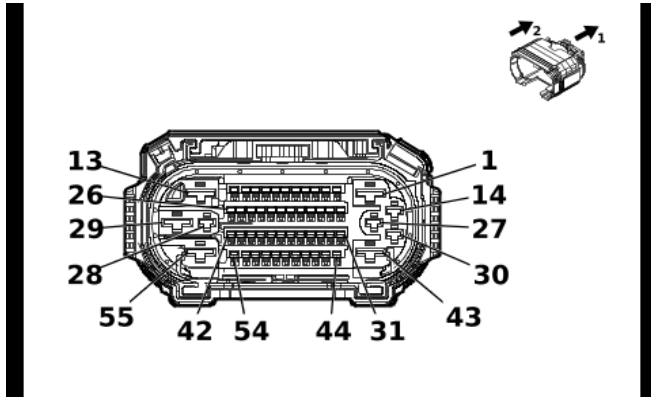

5823852

**Connector Part Information**

Harness Type: Front Seat Wiring Harness - Driver  
 OEM Connector: 35572204  
 Service Connector: Service by Harness - See Part Catalog  
 Description: 55-Way F 1.2 OCS, 2.8, 6.3 CTS Series, Sealed( BK)

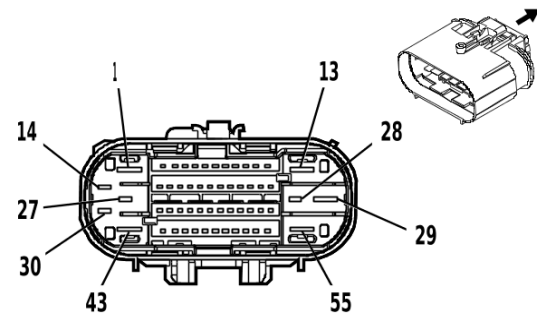

4993301

**Connector Part Information**

Harness Type: Body Wiring Harness  
 OEM Connector: 35588064  
 Service Connector: 84727364  
 Description: 55-Way M 1.2 OCS, 2.8, 6.3 CTS Series, Sealed( BK)

**Terminal Part Information**

Terminal Type ID	Terminated Lead	Diagnostic Test Probe	Terminal Removal Tool
I	Not required	J-35616-16 (L-GN)	No Tool Required
II	Not required	J-35616-42 (RD)	No Tool Required
III	Not required	No Tool Required	No Tool Required
IV	84847992	J-35616-32 (OG)	J-38125-36
V	84867140	J-35616-13 (BU)	J-38125-215A

**X331 Front Seat Wiring Harness - Driver to Body Wiring Harness**

Pin	Size	Color	Circuit	Terminal Type ID	Option	Function	Pin	Size	Color	Circuit	Terminal Type ID	Option
1	2.5	BK	1550	II	—	Ground	1	2.5	BK	1550	IV	—
2-3	—	—	—	—	—	Not Occupied	2-3	—	—	—	—	—
4	0.5 0.75	RD / BN RD / BN	2240 2240	I I	A45 - A45	Battery Positive Voltage Battery Positive Voltage	4	0.5	RD / BN	2240	V	—
5	0.35	GN / WH	7530	I	—	Driver Seat Adjuster Memory Module LIN Bus 1	5	0.5	GN / WH	7530	V	—
6	—	—	—	—	—	Not Occupied	6	—	—	—	—	—
7	0.35	WH	615	I	—	Seat Memory Switch Signal 1	7	0.35	WH	615	V	—
8	0.35	BU / GN	614	I	—	Seat Memory Switch Set Signal	8	0.35	BU / GN	614	V	—
9-14	—	—	—	—	—	Not Occupied	9-14	—	—	—	—	—

**X331 Front Seat Wiring Harness - Driver to Body Wiring Harness (cont'd)**

Pin	Size	Color	Circuit	Terminal Type ID	Option	Function	Pin	Size	Color	Circuit	Terminal Type ID	Option
15	0.75	BN / VT	2077	I	—	Driver Seat Heating Element Control	15	0.75	BN / VT	2077	V	—
16	0.75	BN / BK	2078	I	—	Driver Seat Heating Element Low Reference	16	0.75	BN / BK	2078	V	—
17	0.5	YE / GY	2079	I	—	Driver Seat Heating Temperature Sensor Signal	17	0.5	YE / GY	2079	V	—
18	0.5	BK / YE	2080	I	—	Driver Heated Seat Thermistor Low Reference	18	0.5	BK / YE	2080	V	—
19	0.5	BU	2425	I	—	Driver Seat Back Heating Temperature Sensor Signal	19	0.5	BU	2425	V	—
20	0.75	BN	2432	I	—	Driver Seat Back Heating Element Control	20	0.75	BN	2432	V	—
21 - 28	—	—	—	—	—	Not Occupied	21 - 28	—	—	—	—	—
29	2.5	RD / YE	5040	II	—	Battery Positive Voltage	29	2.5	RD / YE	5040	IV	—
30	—	—	—	—	—	Not Occupied	30	—	—	—	—	—
31	0.5	OG / GY	2652	I	—	Driver Seat Belt Sensor Signal	31	0.35	OG / GY	2652	V	—
32	0.5	BK / OG	1363	I	—	Driver Seat Belt Switch Low Reference	32	0.5	BK / OG	1363	V	—
33	—	—	—	—	—	Not Occupied	33	—	—	—	—	—
34	0.5	BK / OG	4963	III	—	Driver Seat Back Air Bag Low Control	34	0.5	BK / OG	4963	V	—
35	0.5	OG / BU	4962	III	—	Driver Seat Back Air Bag High Control	35	0.5	OG / BU	4962	V	—
36 - 40	—	—	—	—	—	Not Occupied	36 - 40	—	—	—	—	—
41	0.35	BU / VT	4101	I	—	AUTOSAR CAN Bus [+] 4 Serial Data	41	0.5	BU / VT	4101	V	—
42	0.35	WH	4100	I	—	AUTOSAR CAN Bus [-] 4 Serial Data	42	0.5	WH	4100	V	—
43 - 49	—	—	—	—	—	Not Occupied	43 - 49	—	—	—	—	—

**6-826 Electrical Component and Inline Harness Connector End Views**

**X331 Front Seat Wiring Harness - Driver to Body Wiring Harness (cont'd)**

Pin	Size	Color	Circuit	Terminal Type ID	Option	Function	Pin	Size	Color	Circuit	Terminal Type ID	Option
50	0.35	BU / VT	4101	I	—	AUTOSAR CAN Bus [+] 4 Serial Data	50	0.5	BU / VT	4101	V	—
51	0.35	WH	4100	I	—	AUTOSAR CAN Bus [-] 4 Serial Data	51	0.5	WH	4100	V	—
52	0.5	GN / VT	5906	I	—	Driver Seat Blower Motor Control 1	52	0.5	GN / VT	5906	V	—
53	0.75	VT / WH	1139	I	—	Run/Crank Ignition 1 Voltage	53	0.75	VT / WH	1139	V	—
54 - 55	—	—	—	—	—	Not Occupied	54 - 55	—	—	—	—	—



**X336 Front Seat Wiring Harness - Passenger to Body Wiring Harness**

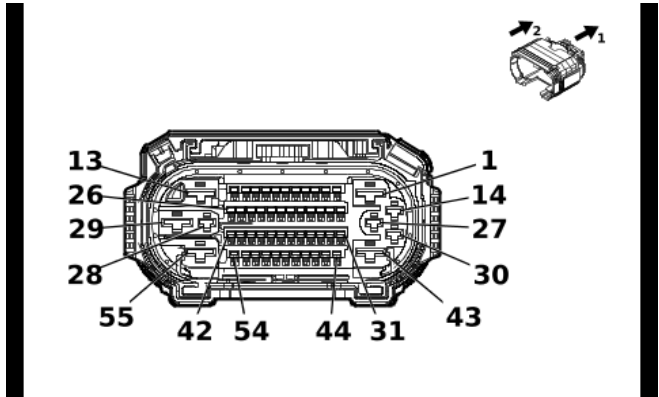

5823852

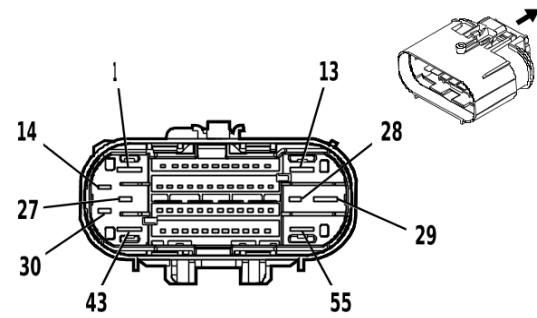

4993301

**Connector Part Information**

Harness Type: Front Seat Wiring Harness - Passenger  
 OEM Connector: 35572205  
 Service Connector: Service by Harness - See Part Catalog  
 Description: 55-Way F 1.2 OCS, 2.8, 6.3 CTS Series, Sealed( BK)

**Connector Part Information**

Harness Type: Body Wiring Harness  
 OEM Connector: 35588064  
 Service Connector: 84727364  
 Description: 55-Way M 1.2 OCS, 2.8, 6.3 CTS Series, Sealed( BK)

**Terminal Part Information**

Terminal Type ID	Terminated Lead	Diagnostic Test Probe	Terminal Removal Tool
I	Not required	J-35616-16 (L-GN)	No Tool Required
II	Not required	J-35616-42 (RD)	No Tool Required
III	Not required	No Tool Required	No Tool Required
IV	84847992	J-35616-32 (OG)	J-38125-36
V	84867140	J-35616-13 (BU)	J-38125-215A

**X336 Front Seat Wiring Harness - Passenger to Body Wiring Harness**

Pin	Size	Color	Circuit	Terminal Type ID	Option	Function	Pin	Size	Color	Circuit	Terminal Type ID	Option
1	2.5	BK	1350	II	A7K	Ground	1	2.5	BK	1350	IV	—
	0.75	BK	1350	II	- A7K	Ground						
2	—	—	—	—	—	Not Occu- pied	2	—	—	—	—	—
3	0.75	RD / GN	6140	I	—	Battery Posi- tive Voltage	3	0.75	RD / GN	6140	V	—
4	0.75	RD / BN	2240	I	A7K	Battery Posi- tive Voltage	4	0.5	RD / BN	2240	V	A7K
5	0.75	RD / BN	6640	I	—	Battery Posi- tive Voltage	5	0.75	RD / BN	6640	V	—
6	—	—	—	—	—	Not Occu- pied	6	—	—	—	—	—
7	0.5	BU	4987	I	—	AUTOSAR CAN Bus [+] 1 Serial Data	7	0.35	BU	4987	V	UKL/ UGN - UKL- UGN
								0.5	BU	4987	V	

**6-828 Electrical Component and Inline Harness Connector End Views**

**X336 Front Seat Wiring Harness - Passenger to Body Wiring Harness (cont'd)**

Pin	Size	Color	Circuit	Terminal Type ID	Option	Function	Pin	Size	Color	Circuit	Terminal Type ID	Option
8	0.5	WH	4986	I	—	AUTOSAR CAN Bus [-] 1 Serial Data	8	0.35 0.5	WH WH	4986 4986	V V	UKL/ UGN - UKL- UGN
9 - 14	—	—	—	—	—	Not Occupied	9 - 14	—	—	—	—	—
15	0.75	BN / VT	2077	I	—	Driver Seat Heating Element Control	15	0.75	BN / VT	2077	V	—
16	0.75	BN / BK	2078	I	—	Driver Seat Heating Element Low Reference	16	0.75	BN / BK	2078	V	—
17	0.5	YE / GY	2079	I	—	Driver Seat Heating Temperature Sensor Signal	17	0.5	YE / GY	2079	V	—
18	0.5	BK / YE	2080	I	—	Driver Heated Seat Thermistor Low Reference	18	0.5	BK / YE	2080	V	—
19	0.5	BU	2425	I	—	Driver Seat Back Heating Temperature Sensor Signal	19	0.5	BU	2425	V	—
20	0.75	BN	2432	I	—	Driver Seat Back Heating Element Control	20	0.75	BN	2432	V	—
21	0.5	GN / VT	2857	I	—	Body Control Module LIN Bus 11	21	0.35	GN / VT	2857	V	—
22	—	—	—	—	—	Not Occupied	22	—	—	—	—	—
23	0.5	RD / GN	4440	I	—	Battery Positive Voltage	23	0.5	RD / GN	4440	V	—
24	0.5	GY / OG	3946	I	—	Passenger Automatic Locking Retractor Switch Low Reference	24	0.35	GY / OG	3946	V	—
25	0.5	OG / BN	3947	I	—	Passenger Automatic Locking Retractor Switch Signal	25	0.35	OG / BN	3947	V	—
26	0.5	BK / WH	1251	I	—	Signal Ground	26	0.5	BK / WH	1251	V	—
27 - 28	—	—	—	—	—	Not Occupied	27 - 28	—	—	—	—	—
29	2.5	RD / GY	7440	II	—	Battery Positive Voltage	29	2.5	RD / YE	7440	IV	—

**X336 Front Seat Wiring Harness - Passenger to Body Wiring Harness (cont'd)**

Pin	Size	Color	Circuit	Terminal Type ID	Option	Function	Pin	Size	Color	Circuit	Terminal Type ID	Option
30	—	—	—	—	—	Not Occupied	30	—	—	—	—	—
31	0.5	OG / VT	1362	I	—	Passenger Seat Belt Switch Signal	31	0.35	OG / VT	1362	V	—
32	0.5	BK / OG	1363	I	—	Driver Seat Belt Switch Low Reference	32	0.5	BK / OG	1363	V	—
33	—	—	—	—	—	Not Occupied	33	—	—	—	—	—
34	0.5	BU / OG	4957	III	—	Passenger Seat Back Air Bag Low Control	34	0.5	BU / OG	4957	V	—
35	0.5	OG / GY	4956	III	—	Passenger Seat Back Air Bag High Control	35	0.5	OG / GY	4956	V	—
36	0.5	GN / VT	5906	I	—	Driver Seat Blower Motor Control 1	36	0.5	GN / VT	5906	V	—
37	0.75	VT / WH	1139	I	—	Run/Crank Ignition 1 Voltage	37	0.75	VT / WH	1139	V	—
38 - 40	—	—	—	—	—	Not Occupied	38 - 40	—	—	—	—	—
41	0.35	BU / VT	4101	I	—	AUTOSAR CAN Bus [+] 4 Serial Data	41	0.5	BU / VT	4101	V	—
42	0.35	WH	4100	I	—	AUTOSAR CAN Bus [-] 4 Serial Data	42	0.5	WH	4100	V	—
43 - 49	—	—	—	—	—	Not Occupied	43 - 49	—	—	—	—	—
50	0.35	BU / VT	4101	I	—	AUTOSAR CAN Bus [+] 4 Serial Data	50	0.5	BU / VT	4101	V	—
51	0.35	WH	4100	I	—	AUTOSAR CAN Bus [-] 4 Serial Data	51	0.5	WH	4100	V	—
52	0.5	BU	4987	I	—	AUTOSAR CAN Bus [+] 1 Serial Data	52	0.5	BU	4987	V	—
53	0.5	WH	4986	I	—	AUTOSAR CAN Bus [-] 1 Serial Data	53	0.5	WH	4986	V	—
54 - 55	—	—	—	—	—	Not Occupied	54 - 55	—	—	—	—	—

**X340 Body Wiring Harness to Rear Seat Heater Control Wiring Harness (KA6)**

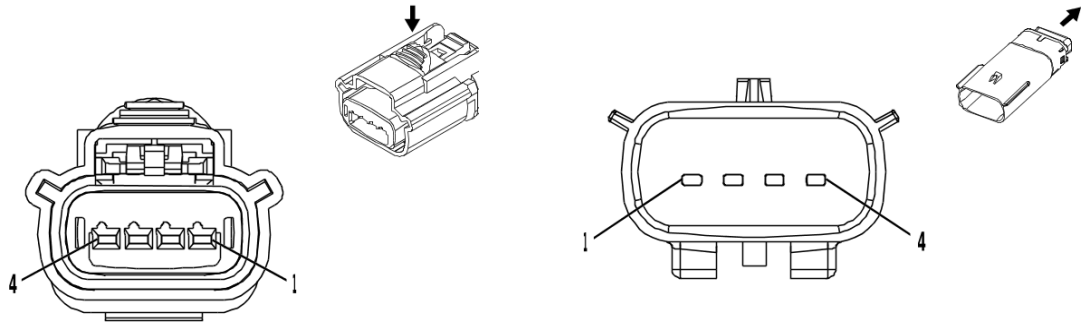

4455251

2917338

**Connector Part Information**

Harness Type: Body Wiring Harness  
 OEM Connector: 15514524  
 Service Connector: 19355605  
 Description: 4-Way F 1.5 OCS Series, Sealed( BK)

**Connector Part Information**

Harness Type: Rear Seat Heater Control Wiring Harness  
 OEM Connector: 33481-4401  
 Service Connector: Service by Harness - See Part Catalog  
 Description: 4-Way M 1.5 Series, Sealed( BK)

**Terminal Part Information**

Terminal Type ID	Terminated Lead	Diagnostic Test Probe	Terminal Removal Tool
I	Not required	J-35616-2A (GY)	No Tool Required
II	Not required	J-35616-3 (GY)	No Tool Required

**X340 Body Wiring Harness to Rear Seat Heater Control Wiring Harness (KA6)**

Pin	Size	Color	Circuit	Terminal Type ID	Option	Function	Pin	Size	Color	Circuit	Terminal Type ID	Option
1	0.75	RD / WH	5740	I	—	Battery Positive Voltage	1	0.75	RD / YE	240	II	—
2	0.75	RD / BU	6740	I	—	Battery Positive Voltage	2	0.75	RD / VT	340	II	—
3	0.35	GN / VT	2857	I	—	Body Control Module LIN Bus 11	3	0.5	GN / BU	6133	II	—
4	1	BK	1550	I	—	Ground	4	1	BK	1150	II	—

**X370 Dome Lamp Wiring Harness to Instrument Panel Wiring Harness (IOK)**

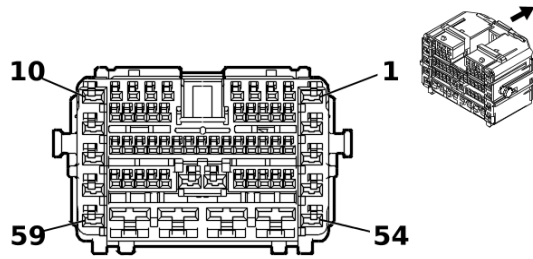

5278767

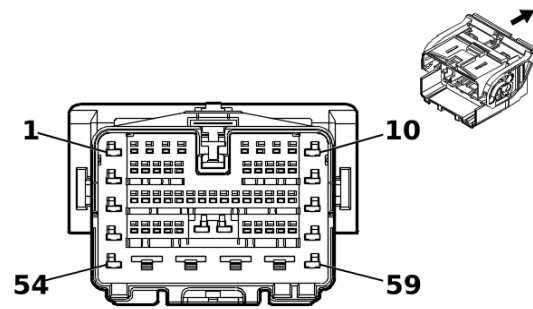

5278741

**Connector Part Information**

Harness Type: Dome Lamp Wiring Harness  
 OEM Connector: 7289-7293-30  
 Service Connector: 13528126  
 Description: 59-Way F 1.2 MCON, 2.8, 6.3 YESC Series( BK)

**Connector Part Information**

Harness Type: Instrument Panel Wiring Harness  
 OEM Connector: 7288-7295-30  
 Service Connector: 84766292  
 Description: 59-Way M 1.2 MCON, 2.8, 6.3 YESC Series( BK)

**Terminal Part Information**

Terminal Type ID	Terminated Lead	Diagnostic Test Probe	Terminal Removal Tool
I	19331733	J-35616-12 (BU)	J-38125-215A
II	85544080	J-35616-4A (PU)	J-38125-11A
III	13578908	J-35616-5 (PU)	J-38125-11A
IV	19330704	J-35616-13 (BU)	J-38125-215A

**X370 Dome Lamp Wiring Harness to Instrument Panel Wiring Harness (IOK)**

Pin	Size	Color	Circuit	Terminal Type ID	Option	Function	Pin	Size	Color	Circuit	Terminal Type ID	Option
1	0.5	RD / YE	240	II	—	Battery Positive Voltage	1	0.5	RD / YE	240	III	—
2	0.35 0.5	VT / BK VT / BK	339 339	I I	( ASV/CE1) - DD8-DRZ-GF2-GF5-GPZ ( DD8-GF2-GF5-GPZ) / ( DRZ-GF2-GF5-GPZ)	Run/Crank Ignition 1 Voltage Run/Crank Ignition 1 Voltage	2	0.5	VT / BK	339	IV	—
3	—	—	—	—	—	Not Occupied	3	—	—	—	—	—
4	0.35	GN / BN	3005	I	—	Active Noise Cancellation Microphone 1 Signal	4	0.35	GN / BN	3005	IV	—

**6-832 Electrical Component and Inline Harness Connector End Views**
**X370 Dome Lamp Wiring Harness to Instrument Panel Wiring Harness (IOK) (cont'd)**

Pin	Size	Color	Circuit	Terminal Type ID	Option	Function	Pin	Size	Color	Circuit	Terminal Type ID	Option
5	0.35	GN / BK	3008	I	—	Active Noise Cancellation Microphone 1 Feedback Signal	5	0.35	GN / BK	3008	IV	—
6	0.35	WH / GY	4104	I	—	AUTOSAR CAN Bus [-] 8 Serial Data	6	0.35	WH / GY	4104	IV	—
7	0.35	BU / GY	4105	I	—	AUTOSAR CAN Bus [+] 8 Serial Data	7	0.35	BU / GY	4105	IV	—
8	0.35	WH / GY	4104	I	—	AUTOSAR CAN Bus [-] 8 Serial Data	8	0.5	WH / GY	4104	IV	—
9	0.35	BU / GY	4105	I	—	AUTOSAR CAN Bus [+] 8 Serial Data	9	0.5	BU / GY	4105	IV	—
10	0.35	YE / WH	1690	II	—	Mirror Dimming Signal	10	0.35	YE / WH	1690	III	—
11	0.35	BK / YE	1691	II	—	Automatic Day/Night Mirror Low Reference	11	0.35	BK / YE	1691	III	—
12	0.35	WH	4978	I	—	AUTOSAR CAN Bus [-] 2 Serial Data	12	0.35	WH	4978	IV	—
13	0.35	BU / YE	4979	I	—	AUTOSAR CAN Bus [+] 2 Serial Data	13	0.35	BU / YE	4979	IV	—
14	0.35	BK / BN	654	I	—	Cellular Telephone Microphone Low Reference	14	0.35	BK / BN	654	IV	—
15	0.35	BU	655	I	—	Cellular Telephone Microphone Signal	15	0.35	BU	655	IV	—
16	0.35	YE / VT	6191	I	—	Power Rear Window Switch Open Signal	16	0.5	YE / VT	6191	IV	—
17	0.35	WH	6192	I	—	Sliding Rear Window Switch Close Signal	17	0.5	WH	6192	IV	—
18	0.5	BU / BK	1053	I	—	Center High Mounted Stop Lamp Control 3	18	0.5	BU / BK	1053	IV	—
19	0.5	WH / VT	1430	I	—	Exterior Courtesy Lamp Control	19	0.5	WH / VT	1430	IV	—
20	0.35	BU / YE	4979	I	—	AUTOSAR CAN Bus [+] 2 Serial Data	20	0.35	BU / RD	4979	IV	—
21	0.35	WH	4978	I	—	AUTOSAR CAN Bus [-] 2 Serial Data	21	0.35	WH / BN	4978	IV	—
22	0.5	GN / WH	24	II	—	Backup Lamp Control	22	0.5	GN / WH	24	III	—

**X370 Dome Lamp Wiring Harness to Instrument Panel Wiring Harness (IOK) (cont'd)**

Pin	Size	Color	Circuit	Terminal Type ID	Option	Function	Pin	Size	Color	Circuit	Terminal Type ID	Option
23	0.35	GN / WH	2514	II	—	Telematics Switch Signal	23	0.35	GN / WH	2514	III	—
24	0.35	GN / BK	2515	I	—	Telematics Switch Supply Voltage	24	0.35	GN / BK	2515	IV	—
25	0.35	YE / VT	2516	I	—	Telematics Switch Green LED Indicator Control	25	0.35	YE / VT	2516	IV	—
26	0.35	BN / WH	2517	I	—	Telematics Switch Red LED Indicator Control	26	0.35	BN / WH	2517	IV	—
27	0.5	GN / WH	2854	I	—	Body Control Module LIN Bus 8	27	0.5	GN / WH	2854	IV	—
28	0.5	GN / WH	4115	I	—	Body Control Module LIN Bus 5	28	0.35	GN / WH	4115	IV	—
29	0.35	VT / YE	7043	I	—	Microphone [+] Signal	29	0.35	VT / YE	7043	IV	—
30	0.35	BU / BK	7044	I	—	Microphone [-] Signal	30	0.35	BU / BK	7044	IV	—
31	0.35	YE	6817	I	—	LED Backlight Dimming Control 1	31	0.35	YE	6817	IV	—
32	0.5	VT	801	I	—	Retained Accessory Power Control	32	0.5	VT	801	IV	—
33	0.5	BN / YE	820	I	—	Center High Mounted Stop Lamp Supply Voltage	33	0.5	BN / YE	820	IV	—
34 - 35	—	—	—	—	—	Not Occupied	34 - 35	—	—	—	—	—
36	0.35	BK / WH	851	I	—	Signal Ground	36	0.5	BK / WH	851	IV	—
37 - 38	—	—	—	—	—	Not Occupied	37 - 38	—	—	—	—	—
39	2.5	VT / BU	10735	II	—	Upfitter Accessory 5 Supply Voltage	39	2.5	VT / BU	10735	III	—
40	2.5	BK	1050	II	—	Ground	40	2.5	BK	1050	III	—
41 - 52	—	—	—	—	—	Not Occupied	41 - 52	—	—	—	—	—
53	2.5	RD / BU	4540	II	—	Battery Positive Voltage	53	2.5	RD / BU	4540	III	—
54 - 59	—	—	—	—	—	Not Occupied	54 - 59	—	—	—	—	—

**X370 Dome Lamp Wiring Harness to Instrument Panel Wiring Harness (IOR)**

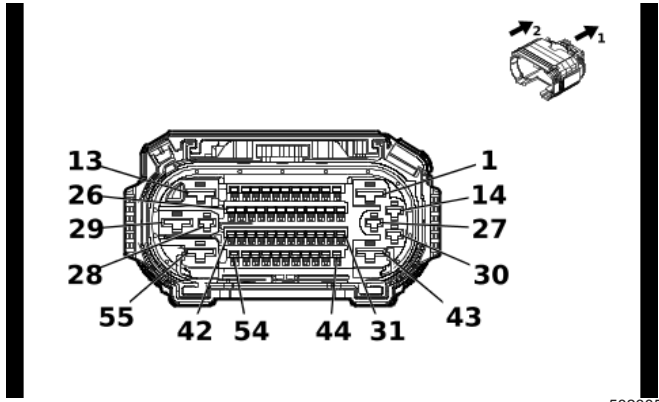

5823852

**Connector Part Information**

Harness Type: Dome Lamp Wiring Harness  
 OEM Connector: 35587201  
 Service Connector: 19371185  
 Description: 55-Way F 1.2 OCS, 2.8, 6.3 CTS Series, Sealed( BK)

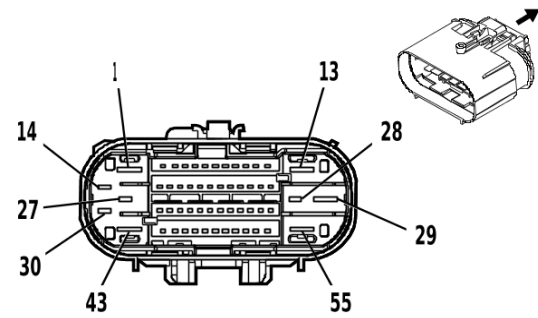

4993301

**Connector Part Information**

Harness Type: Instrument Panel Wiring Harness  
 OEM Connector: 35605246  
 Service Connector: 84727364  
 Description: 55-Way M 1.2 OCS, 2.8, 6.3 CTS Series, Sealed( BK)

**Terminal Part Information**

Terminal Type ID	Terminated Lead	Diagnostic Test Probe	Terminal Removal Tool
I	19332901	J-35616-35 (VT)	J-38125-212
II	19370818	J-35616-12 (BU)	J-38125-215A
III	84634921	J-35616-42 (RD)	J-38125-212
IV	84847992	J-35616-32 (OG)	J-38125-36
V	84867140	J-35616-13 (BU)	J-38125-215A
VI	84992391	J-35616-5 (PU)	J-38125-215A

**X370 Dome Lamp Wiring Harness to Instrument Panel Wiring Harness (IOR)**

Pin	Size	Color	Circuit	Terminal Type ID	Option	Function	Pin	Size	Color	Circuit	Terminal Type ID	Option
1	0.5	RD / YE	240	III	—	Battery Positive Voltage	1	0.5	RD / YE	240	IV	—
2-3	—	—	—	—	—	Not Occupied	2-3	—	—	—	—	—
4	0.35	WH	4978	II	—	AUTOSAR CAN Bus [-] 2 Serial Data	4	0.35	WH	4978	V	—
5	0.35	BU / YE	4979	II	—	AUTOSAR CAN Bus [+] 2 Serial Data	5	0.35	BU / YE	4979	V	—
6	0.35	BK / BN	654	II	—	Cellular Telephone Microphone Low Reference	6	0.35	BK / BN	654	V	—
7	0.35	BU	655	II	—	Cellular Telephone Microphone Signal	7	0.35	BU	655	V	—
8	0.5	BU / BK	1053	II	—	Center High Mounted Stop Lamp Control 3	8	0.5	BU / BK	1053	V	—



**X370 Dome Lamp Wiring Harness to Instrument Panel Wiring Harness (IOR) (cont'd)**

Pin	Size	Color	Circuit	Terminal Type ID	Option	Function	Pin	Size	Color	Circuit	Terminal Type ID	Option
9	0.5	WH / VT	1430	II	—	Exterior Courtesy Lamp Control	9	0.5	WH / VT	1430	V	—
10	0.5	GN / WH	24	II	—	Backup Lamp Control	10	0.5	GN / WH	24	V	—
11	0.35	GN / WH	2514	II	—	Telematics Switch Signal	11	0.35	GN / WH	2514	V	—
12 - 13	—	—	—	—	—	Not Occupied	12 - 13	—	—	—	—	—
14	0.35	BN / WH	2517	I	—	Telematics Switch Red LED Indicator Control	14	0.35	BN / WH	2517	VI	—
15	0.5	GN / WH	2854	II	—	Body Control Module LIN Bus 8	15	0.5	GN / WH	2854	V	—
16	—	—	—	—	—	Not Occupied	16	—	—	—	—	—
17	0.5	BN / YE	820	II	—	Center High Mounted Stop Lamp Supply Voltage	17	0.5	BN / YE	820	V	—
18	0.35	YE / VT	2516	II	—	Telematics Switch Green LED Indicator Control	18	0.35	YE / VT	2516	V	—
19	—	—	—	—	—	Not Occupied	19	—	—	—	—	—
20	0.35	BK / WH	851	II	—	Signal Ground	20	0.5	BK / WH	851	V	—
21	0.5	VT / BK	339	II	—	Run/Crank Ignition 1 Voltage	21	0.5	VT / BK	339	V	—
22 - 26	—	—	—	—	—	Not Occupied	22 - 26	—	—	—	—	—
27	2.5	BK	1050	I	—	Ground	27	2.5	BK	1050	VI	—
28	2.5	VT / BU	10735	I	—	Upfitter Accessory 5 Supply Voltage	28	2.5	VT / BU	10735	VI	—
29 - 44	—	—	—	—	—	Not Occupied	29 - 44	—	—	—	—	—
45	0.35	GN / BK	2515	II	—	Telematics Switch Supply Voltage	45	0.35	GN / BK	2515	V	—
46	0.35	WH	4978	II	—	AUTOSAR CAN Bus [-] 2 Serial Data	46	0.35	WH	4978	V	—
47	0.35	BU / YE	4979	II	—	AUTOSAR CAN Bus [+] 2 Serial Data	47	0.35	BU / YE	4979	V	—
48 - 55	—	—	—	—	—	Not Occupied	48 - 55	—	—	—	—	—

**X371 Dome Lamp Wiring Harness to High Mount Stop Lamp Wiring Harness - Regular Cab**

**Connector Part Information**

Harness Type: Dome Lamp Wiring Harness  
 OEM Connector: Not Available  
 Service Connector: Service by Harness - See Part Catalog  
 Description: 3-Way F

**Connector Part Information**

Harness Type: High Mount Stop Lamp Wiring Harness  
 OEM Connector: 7114-4101-02  
 Service Connector: Service by Harness - See Part Catalog  
 Description: 3-Way M

**Terminal Part Information**

Terminal Type ID	Terminated Lead	Diagnostic Test Probe	Terminal Removal Tool
I	Not required	No Tool Required	No Tool Required
II	Not required	Not Available	No Tool Required

**X371 Dome Lamp Wiring Harness to High Mount Stop Lamp Wiring Harness - Regular Cab**

Pin	Size	Color	Circuit	Terminal Type ID	Option	Function	Pin	Size	Color	Circuit	Terminal Type ID	Option
1	0.75	BN	1430	I	—	Exterior Courtesy Lamp Control	1	0.75	BN	1430	II	—
2	0.75	RD	1053	I	—	Center High Mounted Stop Lamp Control 3	2	0.75	RD	1053	II	—
3	0.75	BK	1050	I	—	Ground	3	0.75	BK	1050	II	—

**X371 Inside Rearview Mirror Wiring Harness - Jumper to High Mount Stop Lamp Wiring Harness - Double Cab / Crew Cab**

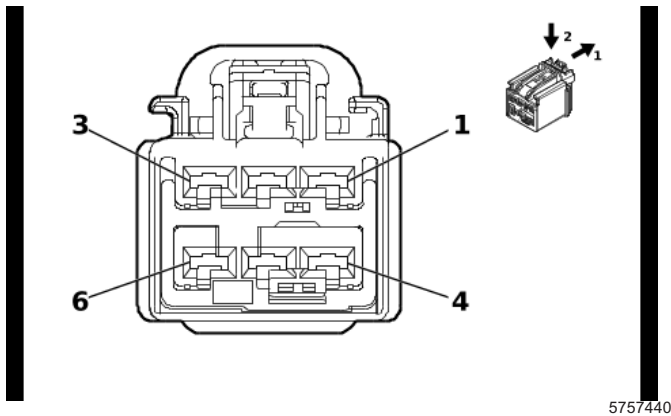

**Connector Part Information**

Harness Type: Inside Rearview Mirror Wiring Harness - Jumper  
 OEM Connector: 7289-7238-40  
 Service Connector: Service by Harness - See Part Catalog  
 Description: 6-Way F 2.8 YESC Series( GY)

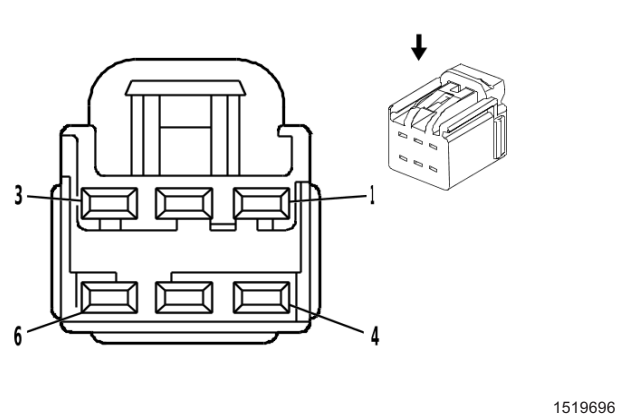

**Connector Part Information**

Harness Type: High Mount Stop Lamp Wiring Harness  
 OEM Connector: Not Available  
 Service Connector: Service by Harness - See Part Catalog  
 Description: 6-Way M ( GY)

**Terminal Part Information**

Terminal Type ID	Terminated Lead	Diagnostic Test Probe	Terminal Removal Tool
I	Not required	J-35616-4A (PU)	No Tool Required
II	Not required	No Tool Required	No Tool Required

**X371 Inside Rearview Mirror Wiring Harness - Jumper to High Mount Stop Lamp Wiring Harness - Double Cab / Crew Cab**

Pin	Size	Color	Circuit	Terminal Type ID	Option	Function	Pin	Size	Color	Circuit	Terminal Type ID	Option
1	0.5	WH / VT	1430	I	—	Exterior Courtesy Lamp Control	1	0.5	WH / VT	1430	II	—
2	0.5	BN / YE	820	I	—	Center High Mounted Stop Lamp Supply Voltage	2	0.5	BN / YE	820	II	—
3	0.5	BK	1050	I	—	Ground	3	0.5	BK	1050	II	—
4	2.5	BK	1050	I	—	Ground	4	2.5	BK	1050	II	—
5	2.5	VT / BU	10735	I	—	Upfitter Accessory 5 Supply Voltage	5	2.5	VT / BU	10735	II	—
6	—	—	—	—	—	Not Occupied	6	—	—	—	—	—

**X375 Sunroof Wiring Harness to Dome Lamp Wiring Harness**

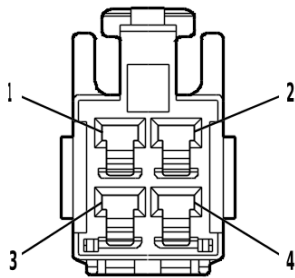

4569115

**Connector Part Information**

Harness Type: Sunroof Wiring Harness  
 OEM Connector: Not Available  
 Service Connector: Service by Harness - See Part Catalog  
 Description: 4-Way F

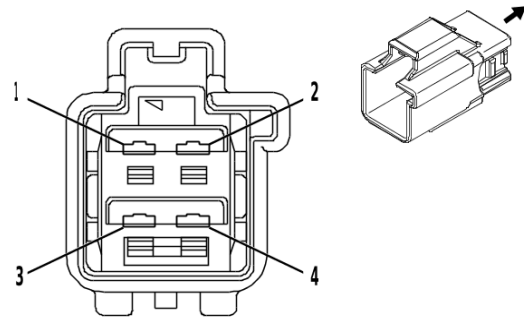

4257143

**Connector Part Information**

Harness Type: Dome Lamp Wiring Harness  
 OEM Connector: 7282-6446-40  
 Service Connector: 89046843  
 Description: 4-Way M 2.8 YESC Series( GY)

**Terminal Part Information**

Terminal Type ID	Terminated Lead	Diagnostic Test Probe	Terminal Removal Tool
I	Not required	No Tool Required	No Tool Required
II	Not required	J-35616-5 (PU)	No Tool Required

**X375 Sunroof Wiring Harness to Dome Lamp Wiring Harness**

Pin	Size	Color	Circuit	Terminal Type ID	Option	Function	Pin	Size	Color	Circuit	Terminal Type ID	Option
1	2.5	BK	1050	I	—	Ground	1	2.5	BK	1050	II	—
2	0.5	GN / WH	2854	I	—	Body Control Module LIN Bus 8	2	0.5	GN / WH	2854	II	—
3	—	—	—	—	—	Not Occupied	3	—	—	—	—	—
4	2.5	RD / BU	4540	I	—	Battery Positive Voltage	4	2.5	RD / BU	4540	II	—

**X381 Rearview Driver Information Camera Rear Closure Coaxial Cable to Inside Rearview Mirror Driver Information Coaxial Cable (DRZ)**

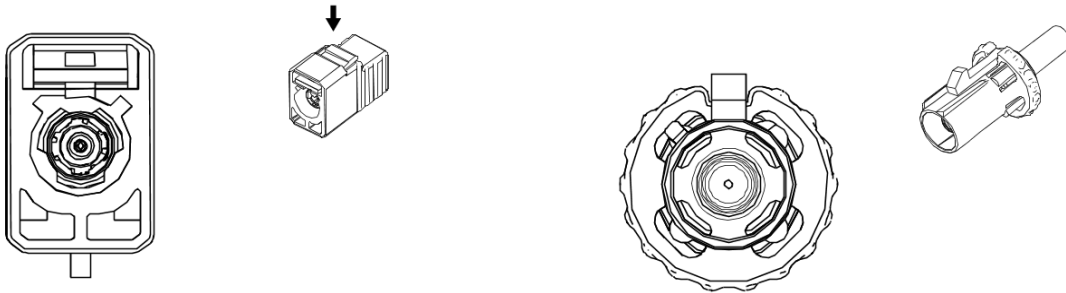

2893647

4109605

**Connector Part Information**

Harness Type: Rearview Driver Information Camera Rear Closure Coaxial Cable COAX  
 OEM Connector: 13581683  
 Service Connector: Service by Cable Assembly — See Part Catalog  
 Description: 1-Way F Coax Type( BK)

**Connector Part Information**

Harness Type: Inside Rearview Mirror Driver Information Coaxial Cable COAX  
 OEM Connector: 13581672  
 Service Connector: Service by Cable Assembly — See Part Catalog  
 Description: 1-Way M Coax Type( BK)

**Terminal Part Information**

Terminal Type ID	Terminated Lead	Diagnostic Test Probe	Terminal Removal Tool
I	Not required	No Tool Required	No Tool Required

**X381 Rearview Driver Information Camera Rear Closure Coaxial Cable to Inside Rearview Mirror Driver Information Coaxial Cable (DRZ)**

Pin	Size	Color	Circuit	Terminal Type ID	Option	Function	Pin	Size	Color	Circuit	Terminal Type ID	Option
—	—	Coax Cable	—	I	—	Full Display Mirror Rear Camera Co-axial Video Signal	—	—	Coax Cable	—	I	—

**X382 Headlamp A to Dome Lamp Wiring Harness**

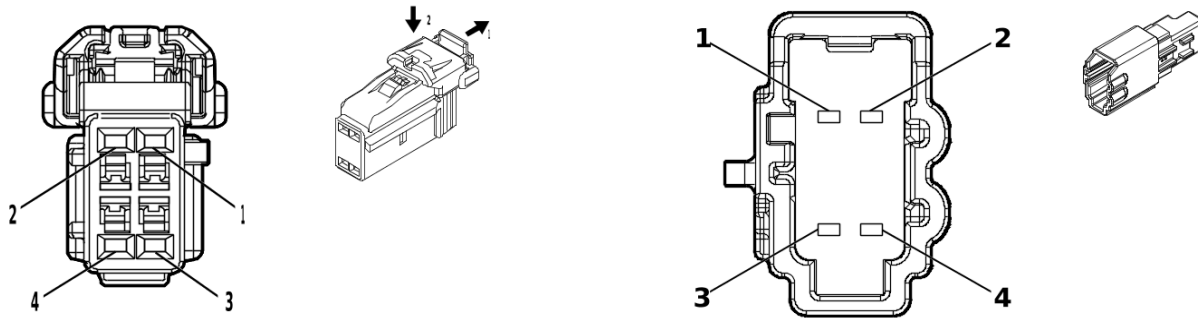

4872683

5360963

**Connector Part Information**

Harness Type: Headlamp A  
 OEM Connector: Not Available  
 Service Connector: Service by Harness - See Part Catalog  
 Description: 4-Way F

**Connector Part Information**

Harness Type: Dome Lamp Wiring Harness  
 OEM Connector: 6098-9046  
 Service Connector: 84847258  
 Description: 4-Way M 1.2 MCON Series( BK)

**Terminal Part Information**

Terminal Type ID	Terminated Lead	Diagnostic Test Probe	Terminal Removal Tool
I	Not required	No Tool Required	No Tool Required
II	Not required	J-35616-13 (BU)	No Tool Required
III	Not required	J-35616-17 (L-GN)	No Tool Required

**X382 Headlamp A to Dome Lamp Wiring Harness**

Pin	Size	Color	Circuit	Terminal Type ID	Option	Function	Pin	Size	Color	Circuit	Terminal Type ID	Option
1	0.35	VT / BK	339	I	—	Run/Crank Ignition 1 Voltage	1	0.35	VT / BK	339	II	—
2	0.5	BK / WH	851	I	—	Signal Ground	2	0.5	BK / WH	851	III	—
3	0.5	GN / WH	4115	I	—	Body Control Module LIN Bus 5	3	0.5	GN / WH	4115	III	—
4	—	—	—	—	—	Not Occupied	4	—	—	—	—	—

**X400 Body Wiring Harness to Chassis Wiring Harness - Double Cab / Crew Cab**

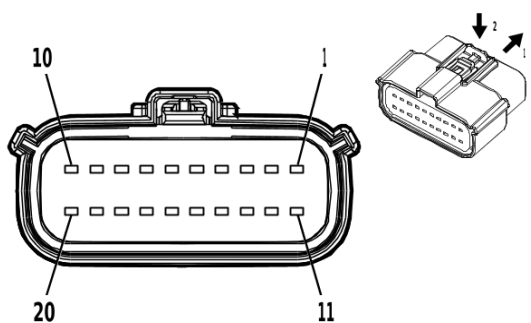

4574194

**Connector Part Information**

Harness Type: Body Wiring Harness  
 OEM Connector: 35482863  
 Service Connector: 19300557  
 Description: 20-Way F 1.5 MX Series, Sealed( BK)

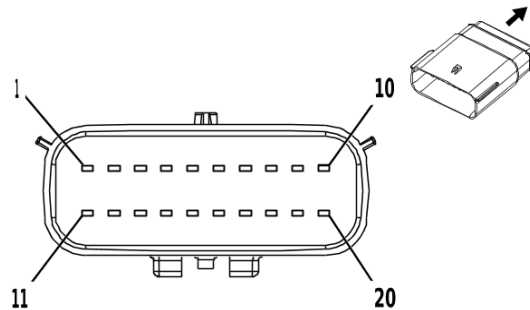

2871861

**Connector Part Information**

Harness Type: Chassis Wiring Harness  
 OEM Connector: 33482-2101  
 Service Connector: 19351705  
 Description: 20-Way M 1.5 MX Series, Sealed( BK)

**Terminal Part Information**

Terminal Type ID	Terminated Lead	Diagnostic Test Probe	Terminal Removal Tool
I	19368973	J-35616-2A (GY)	J-38125-217
II	86800300	J-35616-3 (GY)	J-38125-217

**X400 Body Wiring Harness to Chassis Wiring Harness - Double Cab / Crew Cab**

Pin	Size	Color	Circuit	Terminal Type ID	Option	Function	Pin	Size	Color	Circuit	Terminal Type ID	Option
1-2	—	—	—	—	—	Not Occupied	1-2	—	—	—	—	—
3	0.5	WH	4986	I	—	AUTOSAR CAN Bus [-] 1 Serial Data	3	0.5	WH	4986	II	—
4	0.5	BU	4987	I	—	AUTOSAR CAN Bus [+] 1 Serial Data	4	0.5	BU	4987	II	—
5	0.5	GY	830	I	—	Left Front Wheel Speed Sensor Signal	5	0.5	GY	830	II	—
6	0.5	GY / WH	7064	I	—	Left Front Wheel Speed Sensor Control	6	0.5	GY / WH	7064	II	—
7	0.5	YE	872	I	—	Right Front Wheel Speed Sensor Signal	7	0.5	YE	872	II	—
8	0.5	GY / BN	7065	I	—	Right Front Wheel Speed Sensor Control	8	0.5	GY / BN	7065	II	—
9	0.5	BN / BU	1602	I	—	Front Brake Pad Wear Sensor Signal	9	0.5	BN / BU	1602	II	—

**6-842 Electrical Component and Inline Harness Connector End Views**

**X400 Body Wiring Harness to Chassis Wiring Harness - Double Cab / Crew Cab (cont'd)**

Pin	Size	Color	Circuit	Terminal Type ID	Option	Function	Pin	Size	Color	Circuit	Terminal Type ID	Option
10	0.35	GY	7292	I	—	Major Endgate Release Switch Signal Exterior	10	0.5	GY	7292	II	—
11	0.35	YE	7294	I	—	Minor Endgate Release Switch Discrete Signal Exterior	11	0.5	YE	7294	II	—
12	0.5	BU / WH	4306	I	—	Exhaust Flow Control Valve 1 - Cylinder Deactivation Feedback Signal	12	0.5	BU / WH	4306	II	—
13	0.5	BN / GN	4305	I	—	Exhaust Flow Control Valve 1	13	0.5	BN / GN	4305	II	—
14 - 20	—	—	—	—	—	Not Occupied	14 - 20	—	—	—	—	—



**X400 Body Wiring Harness to Chassis Wiring Harness - Regular Cab**

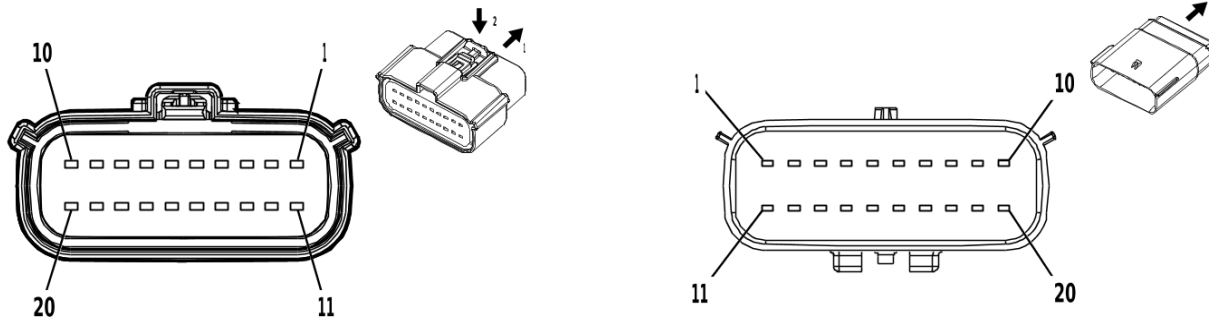

4574194

2871861

**Connector Part Information**

Harness Type: Body Wiring Harness  
 OEM Connector: 35602781  
 Service Connector: 19300557  
 Description: 20-Way F 1.5 MX Series, Sealed( BK)

**Connector Part Information**

Harness Type: Chassis Wiring Harness  
 OEM Connector: 33482-2101  
 Service Connector: 19351705  
 Description: 20-Way M 1.5 MX Series, Sealed( BK)

**Terminal Part Information**

Terminal Type ID	Terminated Lead	Diagnostic Test Probe	Terminal Removal Tool
I	19368973	J-35616-2A (GY)	J-38125-217
II	86800300	J-35616-3 (GY)	J-38125-217

**X400 Body Wiring Harness to Chassis Wiring Harness - Regular Cab**

Pin	Size	Color	Circuit	Terminal Type ID	Option	Function	Pin	Size	Color	Circuit	Terminal Type ID	Option
1-2	—	—	—	—	—	Not Occupied	1-2	—	—	—	—	—
3	0.5	WH	4986	I	—	AUTOSAR CAN Bus [-] 1 Serial Data	3	0.5	WH	4986	II	—
4	0.5	BU	4987	I	—	AUTOSAR CAN Bus [+] 1 Serial Data	4	0.5	BU	4987	II	—
5	0.5	GY	830	I	—	Left Front Wheel Speed Sensor Signal	5	0.5	GY	830	II	—
6	0.5	GY / WH	7064	I	—	Left Front Wheel Speed Sensor Control	6	0.5	GY / WH	7064	II	—
7	0.5	YE	872	I	—	Right Front Wheel Speed Sensor Signal	7	0.5	YE	872	II	—
8	0.5	GY / BN	7065	I	—	Right Front Wheel Speed Sensor Control	8	0.5	GY / BN	7065	II	—
9	0.5	BN / BU	1602	I	—	Front Brake Pad Wear Sensor Signal	9	0.5	BN / BU	1602	II	—

**6-844 Electrical Component and Inline Harness Connector End Views****X400 Body Wiring Harness to Chassis Wiring Harness - Regular Cab (cont'd)**

Pin	Size	Color	Circuit	Terminal Type ID	Option	Function	Pin	Size	Color	Circuit	Terminal Type ID	Option
10	0.35	GY	7292	I	—	Major Endgate Release Switch Signal Exterior	10	0.5	GY	7292	II	—
11	0.35	YE	7294	I	—	Minor Endgate Release Switch Discrete Signal Exterior	11	0.5	YE	7294	II	—
12 - 20	—	—	—	—	—	Not Occupied	12 - 20	—	—	—	—	—

**X401 Engine Wiring Harness to Chassis Wiring Harness**

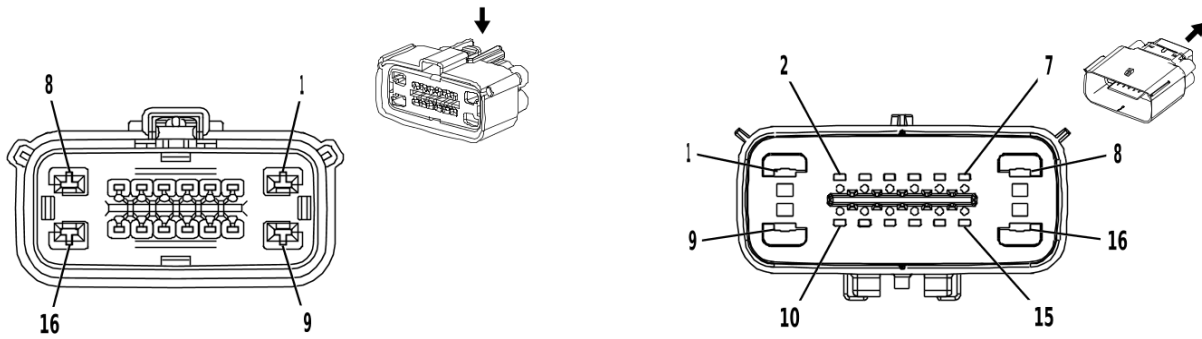

3684497

2373686

**Connector Part Information**

Harness Type: Engine Wiring Harness  
 OEM Connector: 34985-1606  
 Service Connector: 19352906  
 Description: 16-Way F 1.5, 2.8 MX Series, Sealed( BK)

**Connector Part Information**

Harness Type: Chassis Wiring Harness  
 OEM Connector: 34986-1601  
 Service Connector: 19331031  
 Description: 16-Way M 1.5, 2.8 MX Series, Sealed( BK)

**Terminal Part Information**

Terminal Type ID	Terminated Lead	Diagnostic Test Probe	Terminal Removal Tool
I	13576377	J-35616-35 (VT)	J-38125-12A
II	85528055	J-35616-2A (GY)	J-38125-217
III	19366658	J-35616-5 (PU)	J-38125-12A
IV	86800300	J-35616-3 (GY)	J-38125-217

**X401 Engine Wiring Harness to Chassis Wiring Harness**

Pin	Size	Color	Circuit	Terminal Type ID	Option	Function	Pin	Size	Color	Circuit	Terminal Type ID	Option
1-2	—	—	—	—	—	Not Occupied	1-2	—	—	—	—	—
3	0.5	GN / GY	465	II	—	Fuel Pump Primary Relay Control	3	0.5	GN / GY	465	IV	—
4	1	BK / WH	1151	II	—	Signal Ground	4	1	BK / WH	1151	IV	—
5	1.5	VT / GN	4320	II	—	Powertrain Sensor Bus Enable	5	1.5	VT / GN	4320	IV	—
6	0.5	BU / BK	4977	II	—	AUTOSAR CAN Bus [+] 3 Serial Data	6	0.5	BU / BK	4977	IV	—
7	0.5	WH	4976	II	—	AUTOSAR CAN Bus [-] 3 Serial Data	7	0.5	WH	4976	IV	—
8	0.5	BU / RD	460	I	—	Engine Control Sensors 5 Volt Reference 1	8	0.5	BU / RD	460	III	—
9	0.5	BN / GN	4305	I	—	Exhaust Flow Control Valve 1	9	0.5	BN / GN	4305	III	—
10	—	—	—	—	—	Not Occupied	10	—	—	—	—	—

## 6-846 Electrical Component and Inline Harness Connector End Views

### X401 Engine Wiring Harness to Chassis Wiring Harness (cont'd)

Pin	Size	Color	Circuit	Terminal Type ID	Option	Function	Pin	Size	Color	Circuit	Terminal Type ID	Option
11	0.75	YE / BN	1420	II	—	Exhaust Restrictor Motor Open Control	11	0.75	YE / BN	1420	IV	—
12	0.75	BN	1421	II	—	Exhaust Restrictor Motor Closed Control	12	0.75	BN	1421	IV	—
13	0.5	BK / YE	548	II	—	Engine Control Sensors Low Reference 1	13	0.5	BK / YE	548	IV	—
14	0.5	BU / BK	4977	II	—	AUTOSAR CAN Bus [+] 3 Serial Data	14	0.5	BU / BK	4977	IV	—
15	0.5	WH	4976	II	—	AUTOSAR CAN Bus [-] 3 Serial Data	15	0.5	WH	4976	IV	—
16	—	—	—	—	—	Not Occupied	16	—	—	—	—	—

**X402A Body Wiring Harness to Chassis Wiring Harness**

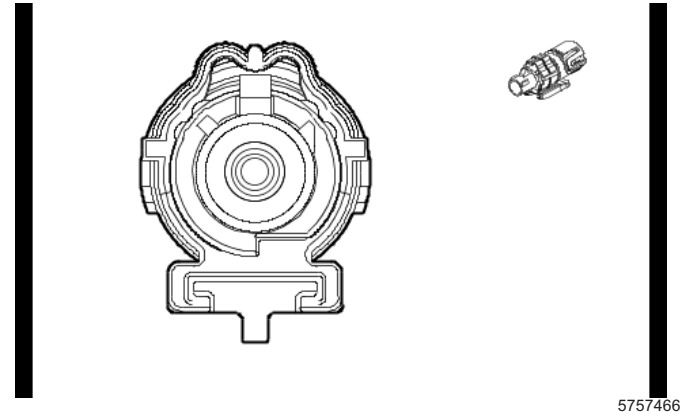
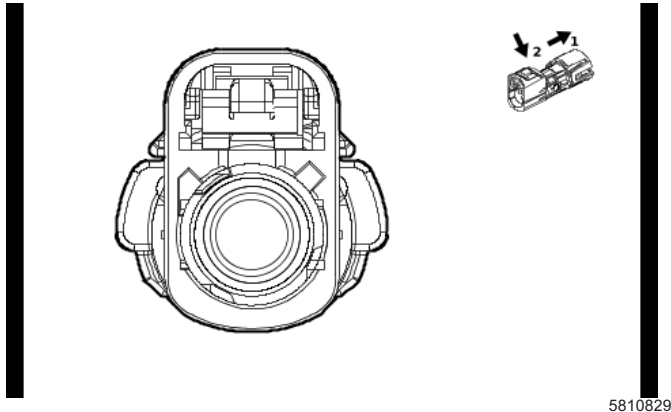

**Connector Part Information**

Harness Type: Body Wiring Harness COAX  
 OEM Connector: 35187033  
 Service Connector: Service by Cable Assembly — See Part Catalog  
 Description: 1-Way F Coax Type( WH)

**Connector Part Information**

Harness Type: Chassis Wiring Harness COAX  
 OEM Connector: 33338240  
 Service Connector: Service by Cable Assembly — See Part Catalog  
 Description: 1-Way M Coax Type, Sealed( WH)

**Terminal Part Information**

Terminal Type ID	Terminated Lead	Diagnostic Test Probe	Terminal Removal Tool
I	Not required	No Tool Required	No Tool Required

**X402A Body Wiring Harness to Chassis Wiring Harness**

Pin	Size	Color	Circuit	Terminal Type ID	Option	Function	Pin	Size	Color	Circuit	Terminal Type ID	Option
—	—	Coax Cable	—	I	—	Trailer 2 Rear Vision Camera Co-axial Video Signal	—	—	Coax Cable	—	I	—

**X402B Body Wiring Harness to Chassis Wiring Harness**

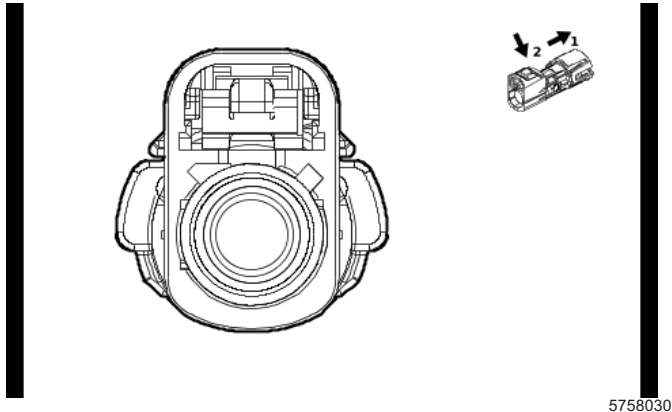

5758030

**Connector Part Information**

Harness Type: Body Wiring Harness COAX  
 OEM Connector: 35187032  
 Service Connector: Service by Cable Assembly — See Part Catalog  
 Description: 1-Way F Coax Type( BK)

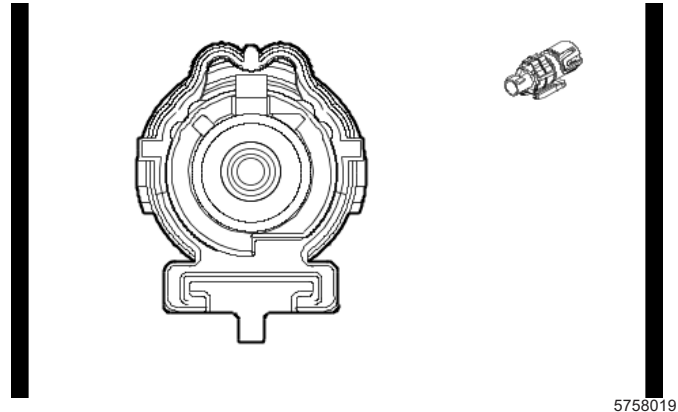

5758019

**Connector Part Information**

Harness Type: Chassis Wiring Harness COAX  
 OEM Connector: 33338239  
 Service Connector: Service by Cable Assembly — See Part Catalog  
 Description: 1-Way M Coax Type, Sealed( BK)

**Terminal Part Information**

Terminal Type ID	Terminated Lead	Diagnostic Test Probe	Terminal Removal Tool
I	Not required	No Tool Required	No Tool Required

**X402B Body Wiring Harness to Chassis Wiring Harness**

Pin	Size	Color	Circuit	Terminal Type ID	Option	Function	Pin	Size	Color	Circuit	Terminal Type ID	Option
—	—	Coax Cable	—	I	—	Trailer Rear Vision Camera Coaxial Video Signal	—	—	Coax Cable	—	I	—

### X402C Body Wiring Harness to Chassis Wiring Harness

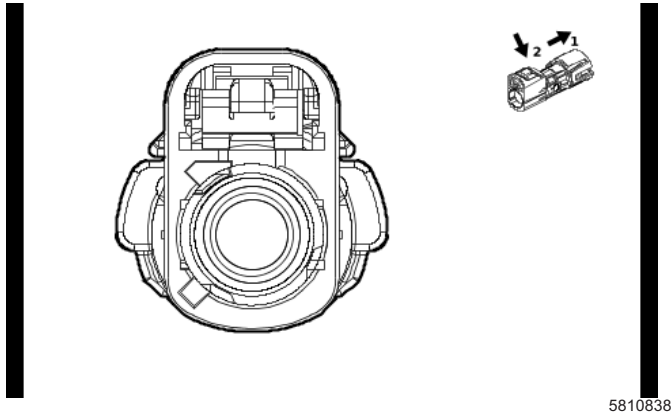

**Connector Part Information**

Harness Type: Body Wiring Harness COAX  
 OEM Connector: 35187037  
 Service Connector: Service by Cable Assembly — See Part Catalog  
 Description: 1-Way F Coax Type( BN)

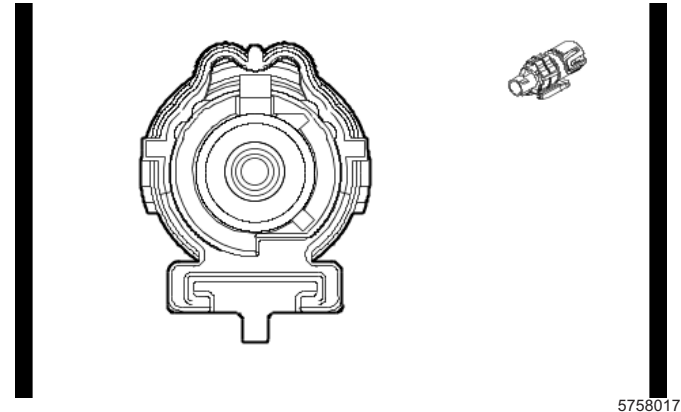

**Connector Part Information**

Harness Type: Chassis Wiring Harness COAX  
 OEM Connector: 33338245  
 Service Connector: Service by Cable Assembly — See Part Catalog  
 Description: 1-Way M Coax Type, Sealed( BN)

**Terminal Part Information**

Terminal Type ID	Terminated Lead	Diagnostic Test Probe	Terminal Removal Tool
I	Not required	No Tool Required	No Tool Required

**X402C Body Wiring Harness to Chassis Wiring Harness**

Pin	Size	Color	Circuit	Terminal Type ID	Option	Function	Pin	Size	Color	Circuit	Terminal Type ID	Option
—	—	Coax Cable	—	I	—	Rear Vision Camera Co-axial Video Signal	—	—	Coax Cable	—	I	—

**X403 Chassis Wiring Harness to Power Steering Wiring Harness Extension Harness - Double Cab / Crew Cab**

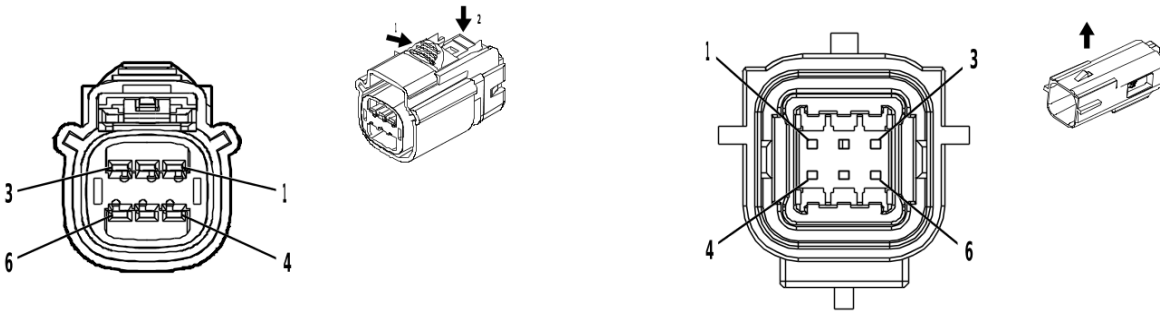

5004419

4053925

**Connector Part Information**

Harness Type: Chassis Wiring Harness  
 OEM Connector: 35325491  
 Service Connector: 84999473  
 Description: 6-Way F 1.5 OCS Series, Sealed( BK)

**Connector Part Information**

Harness Type: Power Steering Wiring Harness Extension Harness  
 OEM Connector: Not Available  
 Service Connector: Service by Harness - See Part Catalog  
 Description: 6-Way M ( BK)

**Terminal Part Information**

Terminal Type ID	Terminated Lead	Diagnostic Test Probe	Terminal Removal Tool
I	Not required	J-35616-2A (GY)	No Tool Required
II	Not required	No Tool Required	No Tool Required

**X403 Chassis Wiring Harness to Power Steering Wiring Harness Extension Harness - Double Cab / Crew Cab**

Pin	Size	Color	Circuit	Terminal Type ID	Option	Function	Pin	Size	Color	Circuit	Terminal Type ID	Option
1	0.5	BU	4987	I	—	AUTOSAR CAN Bus [+] 1 Serial Data	1	0.5	BU	4987	II	—
2-5	—	—	—	—	—	Not Occupied	2-5	—	—	—	—	—
6	0.5	WH	4986	I	—	AUTOSAR CAN Bus [-] 1 Serial Data	6	0.5	WH	4986	II	—



**X403 Chassis Wiring Harness to Power Steering Wiring Harness Extension Harness - Regular Cab**

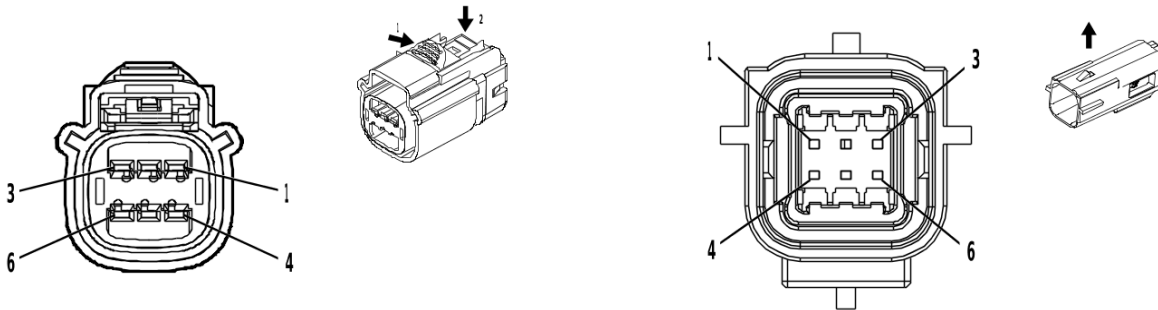

5004419

4053925

**Connector Part Information**

Harness Type: Chassis Wiring Harness  
 OEM Connector: 15513504  
 Service Connector: 84999473  
 Description: 6-Way F 1.5 OCS Series, Sealed( BK)

**Connector Part Information**

Harness Type: Power Steering Wiring Harness Extension Harness  
 OEM Connector: Not Available  
 Service Connector: Service by Harness - See Part Catalog  
 Description: 6-Way M ( BK)

**Terminal Part Information**

Terminal Type ID	Terminated Lead	Diagnostic Test Probe	Terminal Removal Tool
I	Not required	J-35616-2A (GY)	No Tool Required
II	Not required	No Tool Required	No Tool Required

**X403 Chassis Wiring Harness to Power Steering Wiring Harness Extension Harness - Regular Cab**

Pin	Size	Color	Circuit	Terminal Type ID	Option	Function	Pin	Size	Color	Circuit	Terminal Type ID	Option
1	0.5	BU	4987	I	—	AUTOSAR CAN Bus [+] 1 Serial Data	1	0.5	BU	4987	II	—
2-5	—	—	—	—	—	Not Occupied	2-5	—	—	—	—	—
6	0.5	WH	4986	I	—	AUTOSAR CAN Bus [-] 1 Serial Data	6	0.5	WH	4986	II	—

## X404 Emission Reduction Fluid Tank Reservoir Wire Harness to Chassis Wiring Harness

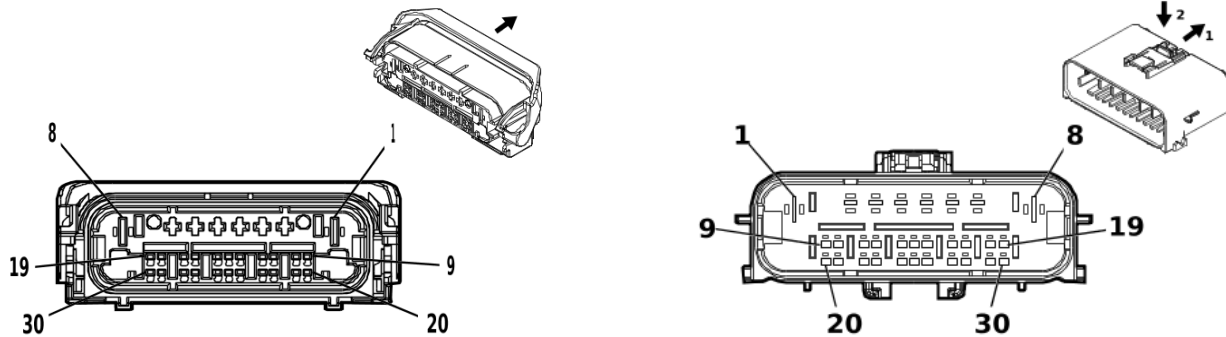

4650150

5377298

### Connector Part Information

Harness Type: Emission Reduction Fluid Tank Reservoir Wire Harness  
 OEM Connector: Not Available  
 Service Connector: Service by Harness - See Part Catalog  
 Description: 30-Way F

### Connector Part Information

Harness Type: Chassis Wiring Harness  
 OEM Connector: 35538391  
 Service Connector: 84861014  
 Description: 30-Way M 1.2 MCON, 2.8, 6.3 MCP Series, Sealed( GY)

### Terminal Part Information

Terminal Type ID	Terminated Lead	Diagnostic Test Probe	Terminal Removal Tool
I	Not required	No Tool Required	No Tool Required
II	13575376	J-35616-32 (OG)	J-38125-36
III	13578827	J-35616-5 (PU)	J-38125-36
IV	19330704	J-35616-13 (BU)	J-38125-215A

### X404 Emission Reduction Fluid Tank Reservoir Wire Harness to Chassis Wiring Harness

Pin	Size	Color	Circuit	Terminal Type ID	Option	Function	Pin	Size	Color	Circuit	Terminal Type ID	Option
1	2.5	RD / WH	2040	I	—	Battery Positive Voltage	1	2.5	RD / WH	2040	II	—
2	1.5	RD / WH	3440	I	—	Battery Positive Voltage	2	1.5	RD / WH	3440	III	—
3 - 6	—	—	—	—	—	Not Occupied	3 - 6	—	—	—	—	—
7	1	BK	1650	I	—	Ground	7	1	BK	1650	III	—
8	2.5	BK	1650	I	—	Ground	8	2.5	BK	1650	II	—
9 - 10	—	—	—	—	—	Not Occupied	9 - 10	—	—	—	—	—
11	0.5	BU / BK	4977	I	—	AUTOSAR CAN Bus [+] 3 Serial Data	11	0.5	BU / BK	4977	IV	—
12	0.5	WH	4976	I	—	AUTOSAR CAN Bus [-] 3 Serial Data	12	0.5	WH	4976	IV	—
13 - 21	—	—	—	—	—	Not Occupied	13 - 21	—	—	—	—	—
22	0.5	BU / BK	4977	I	—	AUTOSAR CAN Bus [+] 3 Serial Data	22	0.5	BU / BK	4977	IV	—

**X404 Emission Reduction Fluid Tank Reservoir Wire Harness to Chassis Wiring Harness  
(cont'd)**

Pin	Size	Color	Circuit	Terminal Type ID	Option	Function	Pin	Size	Color	Circuit	Terminal Type ID	Option
23	0.5	WH	4976	I	—	AUTOSAR CAN Bus [-] 3 Serial Data	23	0.5	WH	4976	IV	—
24	—	—	—	—	—	Not Occupied	24	—	—	—	—	—
25	0.5	VT / WH	639	I	—	Run/Crank Ignition 1 Voltage	25	0.5	VT / WH	639	IV	—
26 - 30	—	—	—	—	—	Not Occupied	26 - 30	—	—	—	—	—

**X405 Power Steering Wiring Harness to Power Steering Control Module Wiring Harness**

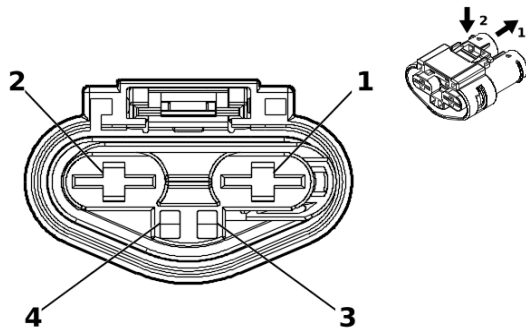

5330342

**Connector Part Information**

Harness Type: Power Steering Wiring Harness  
 OEM Connector: 13508902  
 Service Connector: Service by Harness - See Part Catalog  
 Description: 4-Way F 2.8, 12 MAK Series, Sealed( BK)

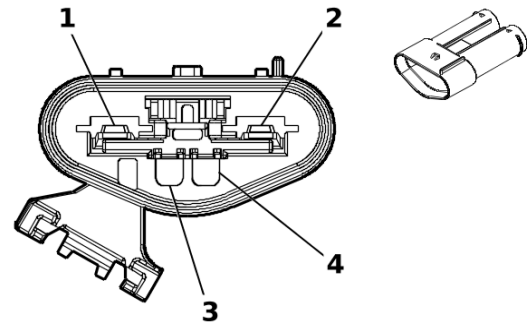

5330353

**Connector Part Information**

Harness Type: Power Steering Control Module Wiring Harness  
 OEM Connector: 13582138  
 Service Connector: Service by Harness - See Part Catalog  
 Description: 4-Way M 2.8, 12 MAK Series, Sealed( BK)

**Terminal Part Information**

Terminal Type ID	Terminated Lead	Diagnostic Test Probe	Terminal Removal Tool
I	Not required	J-35616-3 (GY)	No Tool Required
II	Not required	J-35616-5 (PU)	No Tool Required

**X405 Power Steering Wiring Harness to Power Steering Control Module Wiring Harness**

Pin	Size	Color	Circuit	Terminal Type ID	Option	Function	Pin	Size	Color	Circuit	Terminal Type ID	Option
1	25	BK	350	I	—	Ground	1	20	BK	350	II	—
2	25	RD / VT	3542	I	—	Battery Positive Voltage	2	20	RD	3542	II	—
3-4	—	—	—	—	—	Not Occupied	3-4	—	—	—	—	—

### X410 Chassis Wiring Harness to Body Wiring Harness

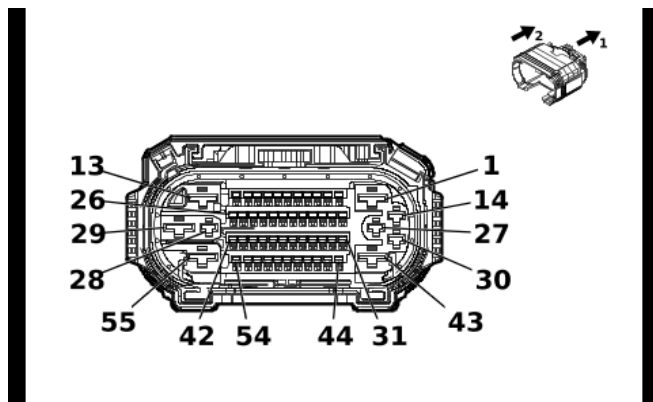

5823852

4993301

#### Connector Part Information

Harness Type: Chassis Wiring Harness  
 OEM Connector: 35588033  
 Service Connector: 19371185  
 Description: 55-Way F 1.2 OCS, 2.8, 6.3 CTS Series, Sealed( BK)

#### Connector Part Information

Harness Type: Body Wiring Harness  
 OEM Connector: 35588063  
 Service Connector: 84727364  
 Description: 55-Way M 1.2 OCS, 2.8, 6.3 CTS Series, Sealed( BK)

#### Terminal Part Information

Terminal Type ID	Terminated Lead	Diagnostic Test Probe	Terminal Removal Tool
I	19332901	J-35616-35 (VT)	J-38125-212
II	19370818	J-35616-12 (BU)	J-38125-215A
III	84634921	J-35616-42 (RD)	J-38125-212
IV	84847992	J-35616-32 (OG)	J-38125-36
V	84867140	J-35616-13 (BU)	J-38125-215A
VI	84992391	J-35616-5 (PU)	J-38125-215A

#### X410 Chassis Wiring Harness to Body Wiring Harness

Pin	Size	Color	Circuit	Terminal Type ID	Option	Function	Pin	Size	Color	Circuit	Terminal Type ID	Option
1	5	GN / VT	1988	III	—	Right Park Brake Motor Apply Control	1	2.5	GN / VT	1988	IV	—
2	0.75	BU / VT	1335	II	—	Right Rear Turn Signal Lamp Control 2	2	0.75	BU / VT	1335	V	—
3	0.5	YE / GN	7122	II	—	Axle Differential Lock Switch Signal	3	0.35	YE / GN	7122	V	—
4	0.5	GN / BU	2733	II	—	Brake System Control Module LIN Bus 2	4	0.5	GN / BU	2733	V	—
5	0.5	BN / GN	3568	II	—	Rear Closure Passive Entry Antenna High Signal	5	0.35	BN / GN	3568	V	—

**6-856 Electrical Component and Inline Harness Connector End Views**

**X410 Chassis Wiring Harness to Body Wiring Harness (cont'd)**

Pin	Size	Color	Circuit	Terminal Type ID	Option	Function	Pin	Size	Color	Circuit	Terminal Type ID	Option
6	0.5	GN / GY	3569	II	—	Rear Closure Passive Entry Antenna Low Signal	6	0.35	GN / GY	3569	V	—
7	0.75	BU / WH	1334	II	—	Left Rear Turn Signal Lamp Control 2	7	0.75	BU / WH	1334	V	—
8	0.5	WH / VT	1430	II	—	Exterior Courtesy Lamp Control	8	0.5	WH / VT	1430	V	—
9	0.5	GN / YE	1616	II	—	Rear Brake Pad Wear Sensor Signal	9	0.5	GN / YE	1616	V	—
10	0.5	WH / BK	2223	II	—	Trailer Brake Apply Signal	10	0.5	WH / BK	2223	V	—
11	0.5	GN / YE	2862	II	—	Body Control Module LIN Bus 16	11	0.35	GN / YE	2862	V	—
12	—	—	—	—	—	Not Occupied	12	—	—	—	—	—
13	5	WH	2001	III	—	Left Park Brake Motor Apply Control	13	2.5	WH	2001	IV	—
14	2.5	RD / VT	4442	I	—	Primary Fused Battery Positive Voltage	14	2.5	RD / VT	4442	VI	—
15	0.5	BU / YE	4979	II	—	AUTOSAR CAN Bus [+] 2 Serial Data	15	0.5	BU / YE	4979	V	—
16	0.5	WH	4978	II	—	AUTOSAR CAN Bus [-] 2 Serial Data	16	0.5	WH	4978	V	—
17	0.5	YE / WH	2377	II	—	Right Rear Middle Parking Assist Sensor Signal	17	0.5	YE / WH	2377	V	—
18	0.75	BN / BU	6993	II	—	Left Rear Park Lamp Control	18	0.75	BN / BU	6993	V	—
19	0.75	WH / BK	7544	II	—	Right Rear Turn Signal Lamp Feedback Signal	19	0.35	WH / BK	7544	V	—
20	—	—	—	—	—	Not Occupied	20	—	—	—	—	—
21	0.5	VT	882	II	—	Right Rear Wheel Speed Sensor Signal	21	0.5	VT	882	V	—
22	0.5	GY / YE	7128	II	—	Right Rear Wheel Speed Sensor Control	22	0.5	GY / YE	7128	V	—

**X410 Chassis Wiring Harness to Body Wiring Harness (cont'd)**

Pin	Size	Color	Circuit	Terminal Type ID	Option	Function	Pin	Size	Color	Circuit	Terminal Type ID	Option
23	0.5	BU	884	II	—	Left Rear Wheel Speed Sensor Signal	23	0.5	BU	884	V	—
24	0.5	GY / BK	7127	II	—	Left Rear Wheel Speed Sensor Control	24	0.5	GY / BK	7127	V	—
25	0.5	YE	7115	II	—	Rear Axle Differential Lock Indicator Control	25	0.35	YE	7115	V	—
26	0.5	BN / YE	820	II	—	Center High Mounted Stop Lamp Supply Voltage	26	0.5	BN / YE	820	V	—
27	—	—	—	—	—	Ground	27	2.5	BK	150	VI	—
28	2.5	BU	47	I	—	Trailer Auxiliary Control	28	2	BU	47	VI	—
29	5	GY / BK	4369	III	—	Left Park Brake Motor Low Reference	29	2.5	GY / BK	4369	IV	—
30	2.5	RD / BN	3640	I	—	Battery Positive Voltage	30	2.5	RD / BN	4142	VI	—
31	0.5	VT / RD	4049	II	—	AC Power Outlet Sensor High Reference	31	0.5	VT / RD	4049	V	—
32	0.35	VT / WH	639	II	—	Run/Crank Ignition 1 Voltage	32	0.5	VT / WH	639	V	—
33	0.5	GY / BU	7762	II	—	Cargo Lamp Control	33	0.5	GY / BU	7762	V	—
34	0.5	YE / BK	2224	II	—	Trailer Brake Enable Signal	34	0.5	YE / BK	2224	V	—
35	0.5	GN / BN	2266	II	—	DC/AC Inverter Control 2	35	0.5	GN / BN	2266	V	—
36	0.5	BN / WH	2374	II	—	Object Sensor Voltage Reference	36	0.5	BN / WH	2374	V	—
37	0.5	YE	2375	II	—	Left Rear Outer Parking Assist Sensor Signal	37	0.5	YE	2375	V	—
38	0.5	YE / BU	2376	II	—	Left Rear Middle Parking Assist Sensor Signal	38	0.5	YE / BU	2376	V	—
39	0.5	WH	4978	II	—	AUTOSAR CAN Bus [-] 2 Serial Data	39	0.35	WH	4978	V	—

**6-858 Electrical Component and Inline Harness Connector End Views**

**X410 Chassis Wiring Harness to Body Wiring Harness (cont'd)**

Pin	Size	Color	Circuit	Terminal Type ID	Option	Function	Pin	Size	Color	Circuit	Terminal Type ID	Option
40	0.5	YE / VT	2378	II	—	Right Rear Outer Parking Assist Sensor Signal	40	0.5	YE / VT	2378	V	—
41	0.5	BK / GY	2379	II	—	Object Sensor Low Reference	41	0.5	BK / GY	2379	V	—
42	0.5	GN / WH	24	II	—	Backup Lamp Control	42	0.5	GN / WH	24	V	—
43	5	GY	4368	III	—	Right Park Brake Motor Low Reference	43	2.5	GY	4368	IV	—
44	0.75	BK / WH	10120	II	—	AC Outlet 2 Phase A Control	44	0.75	BK / WH	10120	V	—
45	0.75	RD / WH	10121	II	—	AC Outlet 2 Phase B Control	45	0.75	RD / WH	10121	V	—
46	0.35	BN	10119	II	—	AC Outlet 2 Low Reference	46	0.35	BN	10119	V	—
47	0.5	VT / GN	4320	II	—	Powertrain Sensor Bus Enable	47	0.5	VT / GN	4320	V	—
48	0.5	VT / GY	7117	II	—	Front Axle Differential Lock Indicator Control	48	0.35	VT / GY	7117	V	—
49	0.5	GN / GY	465	II	—	Fuel Pump Primary Relay Control	49	0.5	GN / GY	465	V	—
50	—	—	—	—	—	Not Occupied	50	—	—	—	—	—
51	0.75	WH / VT	6567	II	—	Rear Turn Signal Lamp Feedback Signal	51	0.35	WH / VT	6567	V	—
52	0.5	GN / YE	6846	II	—	Rear License Plate Lamp Control	52	0.5	GN / YE	6846	V	—
53	0.5	BU / YE	4979	II	—	AUTOSAR CAN Bus [+] 2 Serial Data	53	0.35	BU / YE	4979	V	—
54	0.75	BN / GY	6995	II	—	Right Rear Park Lamp Control	54	0.75	BN / GY	6995	V	—
55	—	—	—	—	—	Battery Positive Voltage	55	6	RD / WH	1642	IV	—



**X412 Assist Wire Jumper - Left to Chassis Wiring Harness (BRS)**

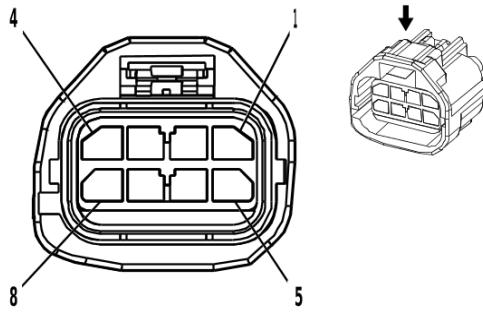

1401778

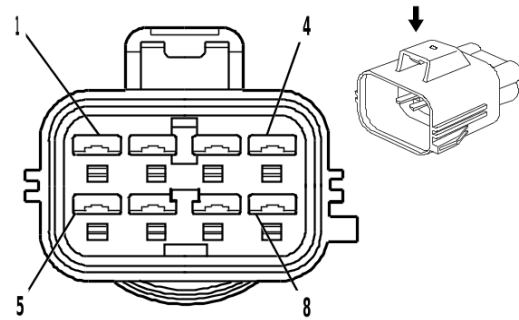

1856785

**Connector Part Information**

Harness Type: Assist Wire Jumper - Left  
 OEM Connector: Not Available  
 Service Connector: Service by Harness - See Part Catalog  
 Description: 8-Way F

**Connector Part Information**

Harness Type: Chassis Wiring Harness  
 OEM Connector: 7282-5574-10  
 Service Connector: 19367561  
 Description: 8-Way M 2.8 YESC Series, Sealed( D-GY)

**Terminal Part Information**

Terminal Type ID	Terminated Lead	Diagnostic Test Probe	Terminal Removal Tool
I	Not required	No Tool Required	No Tool Required
II	Not required	J-35616-5 (PU)	No Tool Required

**X412 Assist Wire Jumper - Left to Chassis Wiring Harness (BRS)**

Pin	Size	Color	Circuit	Terminal Type ID	Option	Function	Pin	Size	Color	Circuit	Terminal Type ID	Option
1	2	GY	7472	I	—	Left Running Board Step Motor Control Retract	1	2	GY	7472	II	—
2	0.5	VT / RD	7468	I	—	Left Running Board Step Motor Hall Sensor 5V Reference	2	0.5	VT / RD	7468	II	—
3	0.5	YE	7467	I	—	Left Running Board Step Motor Hall Sensor Signal	3	0.5	YE	7467	II	—
4	0.5	YE / BN	7466	I	—	Left Running Board Step Motor Hall Sensor Low Reference	4	0.5	YE / BN	7466	II	—
5	2	WH / BN	7471	I	—	Left Running Board Step Motor Control Extend	5	2	WH / BN	7471	II	—
6	—	—	—	—	—	Not Occupied	6	—	—	—	—	—

**6-860 Electrical Component and Inline Harness Connector End Views****X412 Assist Wire Jumper - Left to Chassis Wiring Harness (BRS) (cont'd)**

Pin	Size	Color	Circuit	Terminal Type ID	Option	Function	Pin	Size	Color	Circuit	Terminal Type ID	Option
7	0.5	BU / GN	4746	I	—	Running Board Step Left Kick Switch Signal	7	0.5	BU / GN	4746	II	—
8	0.5	BK / WH	1151	I	—	Signal Ground	8	0.5	BK / WH	1151	II	—

**X413 Assist Step Wire Jumper - Right to Chassis Wiring Harness (BRS)**

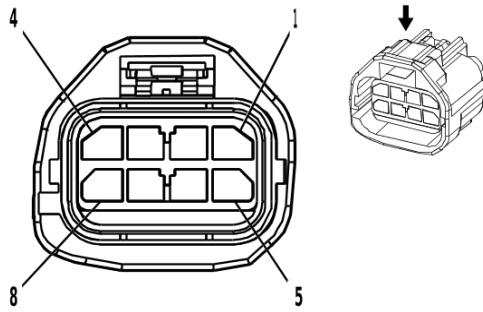

1401778

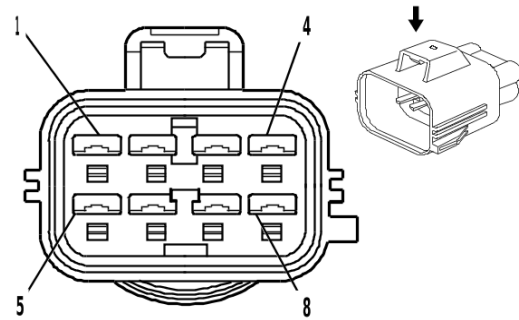

1856785

**Connector Part Information**

Harness Type: Assist Step Wire Jumper - Right  
 OEM Connector: Not Available  
 Service Connector: Service by Harness - See Part Catalog  
 Description: 8-Way F

**Connector Part Information**

Harness Type: Chassis Wiring Harness  
 OEM Connector: 7282-5574-10  
 Service Connector: 19367561  
 Description: 8-Way M 2.8 YESC Series, Sealed( D-GY)

**Terminal Part Information**

Terminal Type ID	Terminated Lead	Diagnostic Test Probe	Terminal Removal Tool
I	Not required	No Tool Required	No Tool Required
II	Not required	J-35616-5 (PU)	No Tool Required

**X413 Assist Step Wire Jumper - Right to Chassis Wiring Harness (BRS)**

Pin	Size	Color	Circuit	Terminal Type ID	Option	Function	Pin	Size	Color	Circuit	Terminal Type ID	Option
1	2	GN	7469	I	—	Right Left Running Board Step Motor Control Retract	1	2	GN	7469	II	—
2	0.5	GN / RD	7464	I	—	Right Running Board Step Motor Hall Sensor 5V Reference	2	0.5	GN / RD	7464	II	—
3	0.5	VT	7465	I	—	Right Running Board Step Motor Hall Sensor Signal	3	0.5	VT	7465	II	—
4	0.5	YE / BK	7463	I	—	Right Running Board Step Motor Hall Sensor Low Reference	4	0.5	YE / BK	7463	II	—
5	2	BU	7470	I	—	Right Running Board Step Motor Control Extend	5	2	BU	7470	II	—
6	—	—	—	—	—	Not Occupied	6	—	—	—	—	—

**6-862 Electrical Component and Inline Harness Connector End Views****X413 Assist Step Wire Jumper - Right to Chassis Wiring Harness (BRS) (cont'd)**

Pin	Size	Color	Circuit	Terminal Type ID	Option	Function	Pin	Size	Color	Circuit	Terminal Type ID	Option
7	0.5	WH	4747	I	—	Running Board Step Right Kick Switch Signal	7	0.5	WH	4747	II	—
8	0.5	BK / WH	1151	I	—	Signal Ground	8	0.5	BK / WH	1151	II	—

### X414 Chassis Rear Wiring Harness to Chassis Wiring Harness

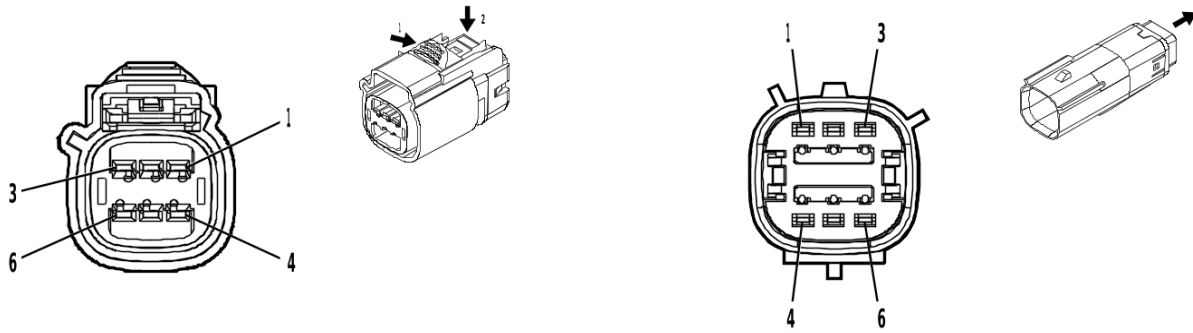

4996962

4992963

#### Connector Part Information

Harness Type: Chassis Rear Wiring Harness  
 OEM Connector: 15513505  
 Service Connector: Service by Harness - See Part Catalog  
 Description: 6-Way F 1.5 OCS Series, Sealed( GY)

#### Connector Part Information

Harness Type: Chassis Wiring Harness  
 OEM Connector: 15513475  
 Service Connector: 19371205  
 Description: 6-Way M 1.5 OCS Series, Sealed( GY)

#### Terminal Part Information

Terminal Type ID	Terminated Lead	Diagnostic Test Probe	Terminal Removal Tool
I	Not required	J-35616-2A (GY)	No Tool Required
II	Not required	J-35616-3 (GY)	No Tool Required

### X414 Chassis Rear Wiring Harness to Chassis Wiring Harness

Pin	Size	Color	Circuit	Terminal Type ID	Option	Function	Pin	Size	Color	Circuit	Terminal Type ID	Option
1	0.75	BK / WH	10120	I	—	AC Outlet 2 Phase A Control AC Outlet 2 Phase A Control	1	0.75	BK / WH	10120	II	—
2	0.5	BN	10119	I	—	AC Outlet 2 Low Reference	2	0.5	BN	10119	II	—
3	0.5	VT / RD	4049	I	—	AC Power Outlet Sensor High Reference	3	0.5	VT / RD	4049	II	—
4	0.75	RD / WH	10121	I	—	AC Outlet 2 Phase B Control AC Outlet 2 Phase B Control	4	0.75	RD / WH	10121	II	—
5	0.5	GN / BN	2266	I	—	DC/AC Inverter Control 2	5	0.5	GN / BN	2266	II	—
6	0.5	BK	1750	I	—	Ground	6	1.5	BK	1750	II	—

**X415A Transfer Case Selector Shift Control Switch Wiring Harness Extension Harness to Engine Wiring Harness (NP0 / NQH)**

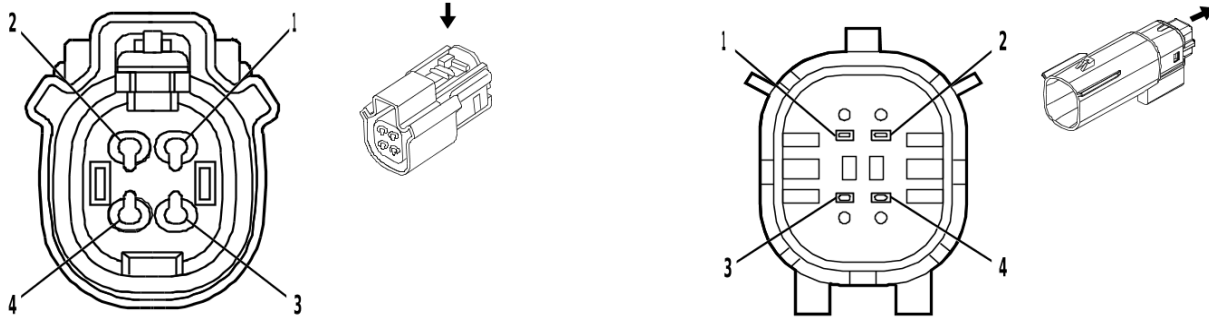

1960031

2368875

**Connector Part Information**

Harness Type: Transfer Case Selector Shift Control Switch Wiring Harness Extension Harness  
 OEM Connector: 33472-4006  
 Service Connector: Service by Harness - See Part Catalog  
 Description: 4-Way F 1.5 MX Series, Sealed( BK)

**Connector Part Information**

Harness Type: Engine Wiring Harness  
 OEM Connector: 33482-4001  
 Service Connector: 84838880  
 Description: 4-Way M 1.5 MX Series, Sealed( BK)

**Terminal Part Information**

Terminal Type ID	Terminated Lead	Diagnostic Test Probe	Terminal Removal Tool
I	Not required	J-35616-2A (GY)	No Tool Required
II	Not required	J-35616-3 (GY)	No Tool Required

**X415A Transfer Case Selector Shift Control Switch Wiring Harness Extension Harness to Engine Wiring Harness (NP0 / NQH)**

Pin	Size	Color	Circuit	Terminal Type ID	Option	Function	Pin	Size	Color	Circuit	Terminal Type ID	Option
1	0.5	GY / BK	1570	I	—	Front Axle Actuator Control Front Axle Actuator Control	1	0.5	GY / BK	1570	II	—
2	0.5	YE / WH	1695	I	—	4WD Locked Range Indicator Control 4WD Locked Range Indicator Control	2	0.5	YE / WH	1695	II	—
3	0.5	GN	8016	I	—	Secondary Axle Motor Control Secondary Axle Motor Control	3	0.5	GN	8016	II	—
4	0.5	BK	450	I	—	Ground Ground	4	0.75 1	BK BK	450 450	II II	L3B+ ( NP0/ NQH) ( L84/ L87) + ( NP0/ NQH)

### X416A Chassis Wiring Harness to Electronic Suspension Strut Wiring Harness Extension Harness (Z45)

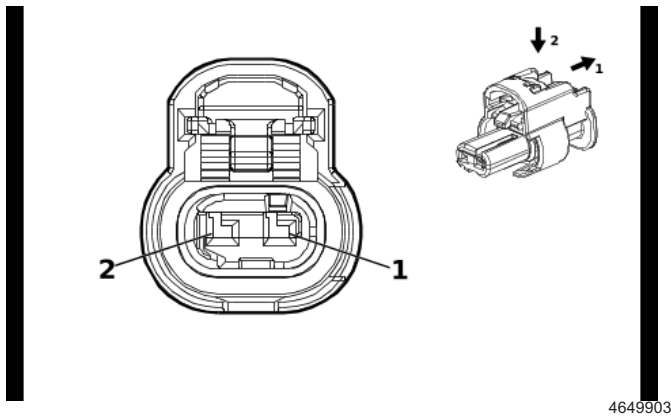

#### Connector Part Information

Harness Type: Chassis Wiring Harness  
 OEM Connector: 1-2296694-1  
 Service Connector: 85519075  
 Description: 2-Way F 1.2 MCON Series, Sealed( BK)

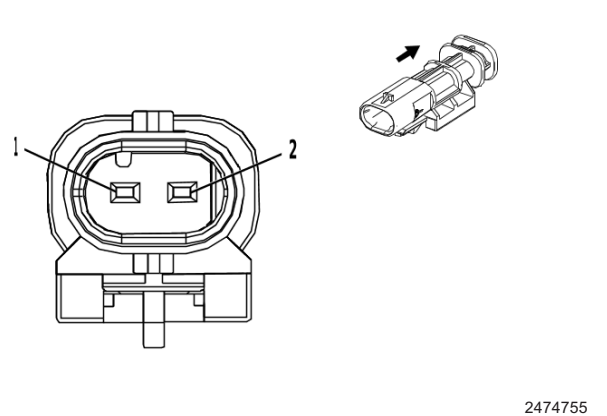

#### Connector Part Information

Harness Type: Electronic Suspension Strut Wiring Harness Extension Harness  
 OEM Connector: 13591337  
 Service Connector: Service by Harness - See Part Catalog  
 Description: 2-Way M 1.2 MCON Series, Sealed( BK)

#### Terminal Part Information

Terminal Type ID	Terminated Lead	Diagnostic Test Probe	Terminal Removal Tool
I	Not required	J-35616-12 (BU)	No Tool Required
II	Not required	J-35616-17 (L-GN)	No Tool Required

### X416A Chassis Wiring Harness to Electronic Suspension Strut Wiring Harness Extension Harness (Z45)

Pin	Size	Color	Circuit	Terminal Type ID	Option	Function	Pin	Size	Color	Circuit	Terminal Type ID	Option
1	0.75	BN / WH	1107	I	—	Left Front Shock Absorber Actuator Control	1	0.75	BU / WH	1107	II	—
2	0.75	GY / BU	1113	I	—	Left Front Shock Absorber Actuator Control	2	0.75	GY	1113	II	—

**X416B Chassis Wiring Harness to Electronic Suspension Strut Wiring Harness Extension Harness (Z45)**

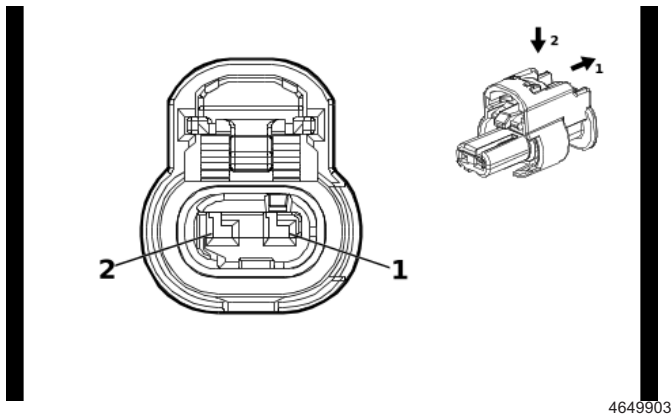

**Connector Part Information**

Harness Type: Chassis Wiring Harness  
 OEM Connector: 1-2296694-1  
 Service Connector: 85519075  
 Description: 2-Way F 1.2 MCON Series, Sealed( BK)

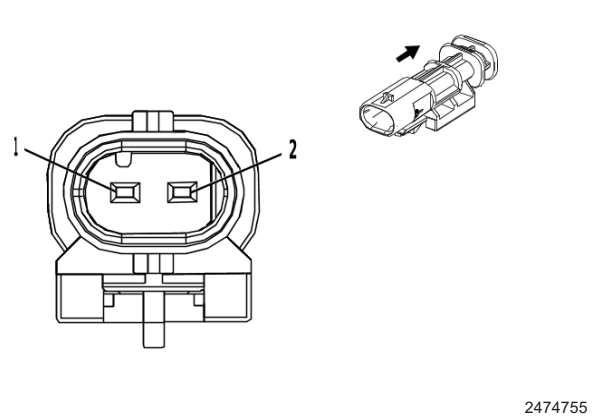

**Connector Part Information**

Harness Type: Electronic Suspension Strut Wiring Harness Extension Harness  
 OEM Connector: 13591337  
 Service Connector: Service by Harness - See Part Catalog  
 Description: 2-Way M 1.2 MCON Series, Sealed( BK)

**Terminal Part Information**

Terminal Type ID	Terminated Lead	Diagnostic Test Probe	Terminal Removal Tool
I	Not required	J-35616-12 (BU)	No Tool Required
II	Not required	J-35616-17 (L-GN)	No Tool Required

**X416B Chassis Wiring Harness to Electronic Suspension Strut Wiring Harness Extension Harness (Z45)**

Pin	Size	Color	Circuit	Terminal Type ID	Option	Function	Pin	Size	Color	Circuit	Terminal Type ID	Option
1	0.75	BN / BU	1116	I	—	Right Front Shock Absorber Actuator Control	1	0.75	BU / WH	1116	II	—
2	0.75	GY / WH	1117	I	—	Right Front Shock Absorber Actuator Control	2	0.75	GY	1117	II	—



### X416C Transfer Case Selector Shift Control Switch Wiring Harness Extension Harness to Chassis Wiring Harness (G93)

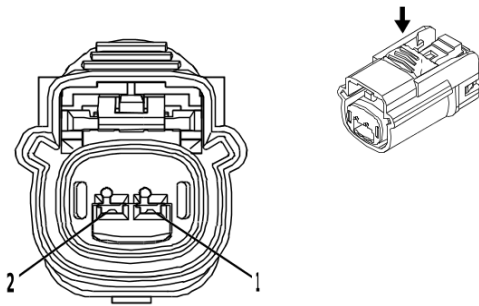

4332222

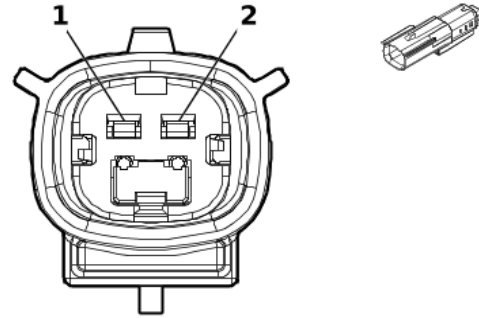

5921817

#### Connector Part Information

Harness Type: Transfer Case Selector Shift Control Switch Wiring Harness Extension Harness  
 OEM Connector: 15514573  
 Service Connector: Service by Harness - See Part Catalog  
 Description: 2-Way F 1.5 OCS Series, Sealed( BK)

#### Connector Part Information

Harness Type: Chassis Wiring Harness  
 OEM Connector: 15514550  
 Service Connector: 86825463  
 Description: 2-Way M 1.5 OCS Series, Sealed( BK)

#### Terminal Part Information

Terminal Type ID	Terminated Lead	Diagnostic Test Probe	Terminal Removal Tool
I	Not required	J-35616-2A (GY)	No Tool Required
II	Not required	J-35616-3 (GY)	No Tool Required

### X416C Transfer Case Selector Shift Control Switch Wiring Harness Extension Harness to Chassis Wiring Harness (G93)

Pin	Size	Color	Circuit	Terminal Type ID	Option	Function	Pin	Size	Color	Circuit	Terminal Type ID	Option
1	0.75	WH / BK	7254	I	—	Front Differential Lock Actuator Low Control	1	0.75	WH / BK	7254	II	—
2	0.75	VT / WH	7256	I	—	Front Differential Lock Actuator Control	2	0.75	VT / WH	7256	II	—

**X417 Transfer Case Selector Shift Control Switch Wiring Harness Extension  
Harness to Front Differential Locking Actuator Jumper Wiring Harness (G93)**

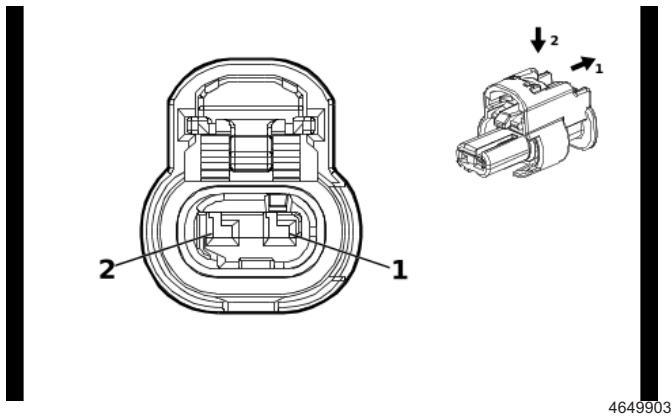

**Connector Part Information**

Harness Type: Transfer Case Selector Shift Control Switch Wiring Harness Extension Harness  
 OEM Connector: 1-2296694-1  
 Service Connector: Service by Harness - See Part Catalog  
 Description: 2-Way F 1.2 MCON Series, Sealed( BK)

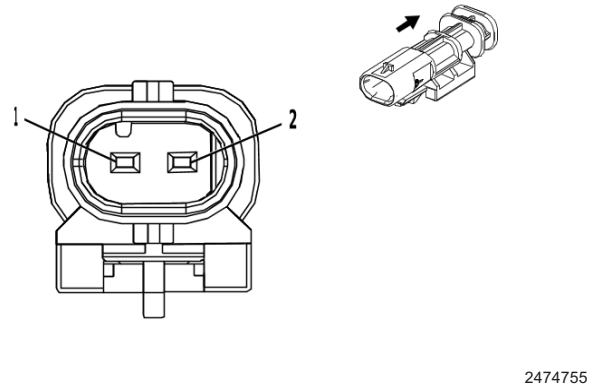

**Connector Part Information**

Harness Type: Front Differential Locking Actuator Jumper Wiring Harness  
 OEM Connector: 13591337  
 Service Connector: Service by Harness - See Part Catalog  
 Description: 2-Way M 1.2 MCON Series, Sealed( BK)

**Terminal Part Information**

Terminal Type ID	Terminated Lead	Diagnostic Test Probe	Terminal Removal Tool
I	Not required	J-35616-12 (BU)	No Tool Required
II	Not required	J-35616-13 (BU)	No Tool Required

**X417 Transfer Case Selector Shift Control Switch Wiring Harness Extension Harness to  
Front Differential Locking Actuator Jumper Wiring Harness (G93)**

Pin	Size	Color	Circuit	Terminal Type ID	Option	Function	Pin	Size	Color	Circuit	Terminal Type ID	Option
1	0.75	VT / WH	7256	I	—	Front Differential Lock Actuator Control	1	0.75	VT / WH	7256	II	—
2	0.75	WH / BK	7254	I	—	Front Differential Lock Actuator Low Control	2	0.75	WH / BK	7254	II	—

## X418 Assist Step Wire Jumper - Left to Assist Step Wire - Left (BRS)

**Connector Part Information**

Harness Type: Assist Step Wire Jumper - Left  
 OEM Connector: Not Available  
 Service Connector: Service by Harness - See Part Catalog  
 Description: 2-Way F

**Connector Part Information**

Harness Type: Assist Step Wire - Left  
 OEM Connector: anr88724  
 Service Connector: Service by Harness - See Part Catalog  
 Description: 2-Way M

### Terminal Part Information

Terminal Type ID	Terminated Lead	Diagnostic Test Probe	Terminal Removal Tool
I	Not required	No Tool Required	No Tool Required
II	Not required	No Tool Required	No Tool Required

### X418 Assist Step Wire Jumper - Left to Assist Step Wire - Left (BRS)

Pin	Size	Color	Circuit	Terminal Type ID	Option	Function	Pin	Size	Color	Circuit	Terminal Type ID	Option
1	0.5	BU / GN	4746	I	—	Running Board Step Left Kick Switch Signal	1	0.5	BU / GN	4746	II	—
2	0.5	BK / WH	1151	I	—	Signal Ground	2	0.5	BK / WH	1151	II	—

**X419 Assist Step Wire Jumper - Right to Assist Step Wire - Right (BRS)**

**Connector Part Information**

Harness Type: Assist Step Wire Jumper - Right  
 OEM Connector: Not Available  
 Service Connector: Service by Harness - See Part Catalog  
 Description: 2-Way F

**Connector Part Information**

Harness Type: Assist Step Wire - Right  
 OEM Connector: anr88724  
 Service Connector: Service by Harness - See Part Catalog  
 Description: 2-Way M

**Terminal Part Information**

Terminal Type ID	Terminated Lead	Diagnostic Test Probe	Terminal Removal Tool
I	Not required	No Tool Required	No Tool Required
II	Not required	No Tool Required	No Tool Required

**X419 Assist Step Wire Jumper - Right to Assist Step Wire - Right (BRS)**

Pin	Size	Color	Circuit	Terminal Type ID	Option	Function	Pin	Size	Color	Circuit	Terminal Type ID	Option
1	0.5	WH	4747	I	—	Running Board Step Right Kick Switch Signal	1	0.5	WH	4747	II	—
2	0.5	BK / WH	1151	I	—	Signal Ground	2	0.5	BK / WH	1151	II	—

**X420A Chassis Rear Wiring Harness Extension Harness to Chassis Wiring Harness**

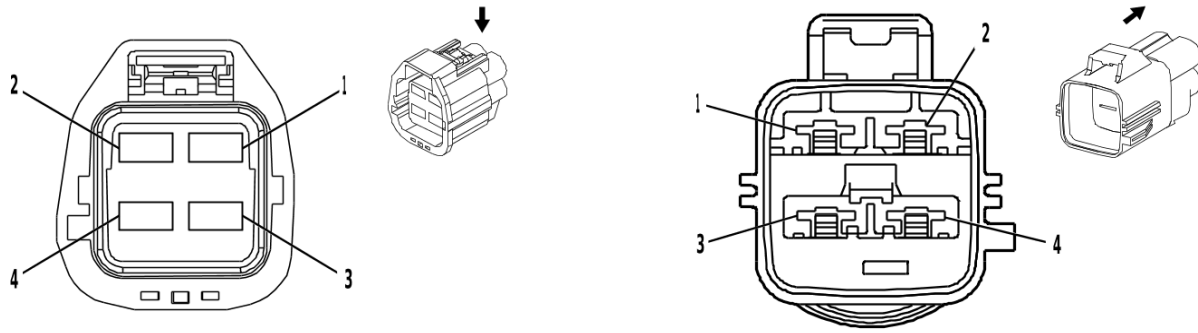

2852121

1853524

**Connector Part Information**

Harness Type: Chassis Rear Wiring Harness Extension Harness  
 OEM Connector: 7283-3601-10  
 Service Connector: Service by Harness - See Part Catalog  
 Description: 4-Way F 6.3 Series, Sealed( GY)

**Connector Part Information**

Harness Type: Chassis Wiring Harness  
 OEM Connector: 7288-3029-10  
 Service Connector: 19371198  
 Description: 4-Way M 6.3 Series, Sealed( GY)

**Terminal Part Information**

Terminal Type ID	Terminated Lead	Diagnostic Test Probe	Terminal Removal Tool
I	Not required	J-35616-42 (RD)	No Tool Required
II	Not required	J-35616-43 (RD)	No Tool Required

**X420A Chassis Rear Wiring Harness Extension Harness to Chassis Wiring Harness**

Pin	Size	Color	Circuit	Terminal Type ID	Option	Function	Pin	Size	Color	Circuit	Terminal Type ID	Option
1	2.5	WH	2001	I	- Z45+ Z45+ G94	Left Park Brake Motor Apply Control	1	5	WH	2001	II	—
2	2.5	GY / BK	4369	I	- Z45+ Z45+ G94	Left Park Brake Motor Low Reference	2	5	GY / BK	4369	II	—
3	2.5	GN / VT	1988	I	- Z45+ Z45+ G94	Right Park Brake Motor Apply Control	3	5	GN / VT	1988	II	—
4	2.5	GY	4368	I	- Z45+ Z45+ G94	Right Park Brake Motor Low Reference	4	5	GY	4368	II	—

**X420B Chassis Rear Wiring Harness Extension Harness to Chassis Wiring Harness (- Z45)**

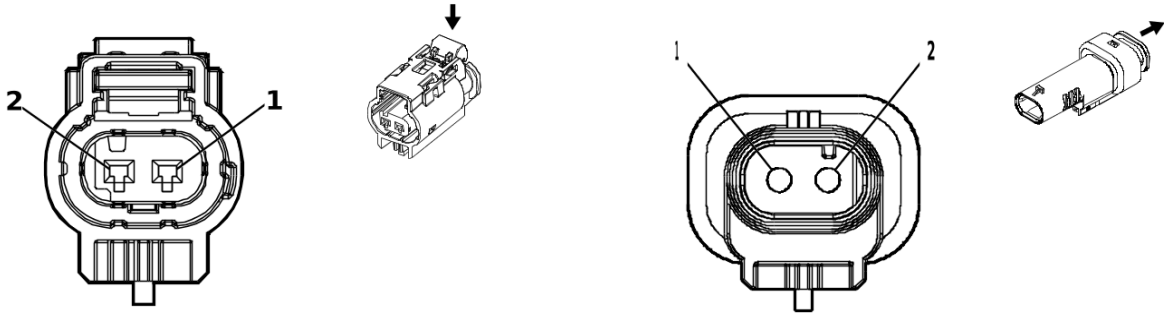

5207726

4992757

**Connector Part Information**

Harness Type: Chassis Rear Wiring Harness Extension Harness  
 OEM Connector: 13583199  
 Service Connector: Service by Harness - See Part Catalog  
 Description: 2-Way F 1.2 Multilock Series, Sealed( GY)

**Connector Part Information**

Harness Type: Chassis Wiring Harness  
 OEM Connector: 10094251  
 Service Connector: 19371200  
 Description: 2-Way M 1.2 MLK Series, Sealed( GY)

**Terminal Part Information**

Terminal Type ID	Terminated Lead	Diagnostic Test Probe	Terminal Removal Tool
I	Not required	J-35616-16 (L-GN)	No Tool Required
II	Not required	J-35616-17 (L-GN)	No Tool Required

**X420B Chassis Rear Wiring Harness Extension Harness to Chassis Wiring Harness (- Z45)**

Pin	Size	Color	Circuit	Terminal Type ID	Option	Function	Pin	Size	Color	Circuit	Terminal Type ID	Option
1	0.75	GN / YE	1616	I	- Z45	Rear Brake Pad Wear Sensor Signal	1	0.5	GN / YE	1616	II	—
2	0.75	BK / WH	1751	I	- Z45	Signal Ground	2	0.5	BK / WH	1951	II	—

### X420B Chassis Wiring Harness to Chassis Rear Wiring Harness Extension Harness (Z45)

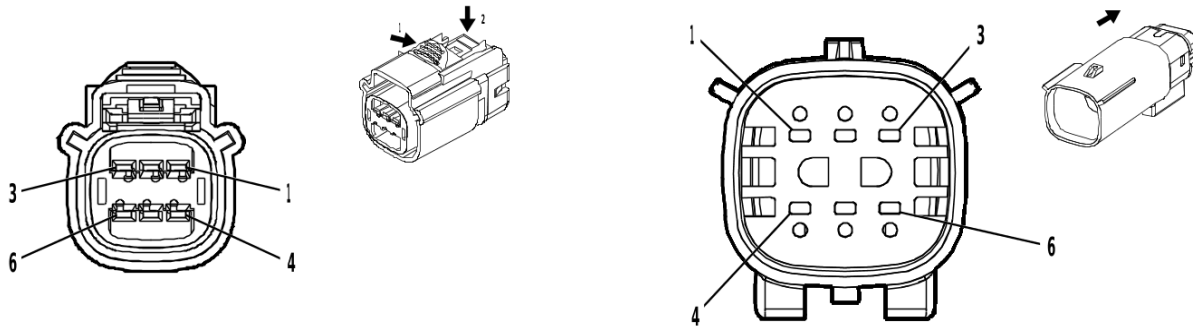

5004419

1986159

#### Connector Part Information

Harness Type: Chassis Wiring Harness  
 OEM Connector: 15513504  
 Service Connector: 84999473  
 Description: 6-Way F 1.5 OCS Series, Sealed( BK)

#### Connector Part Information

Harness Type: Chassis Rear Wiring Harness Extension Harness  
 OEM Connector: 33482-3601  
 Service Connector: Service by Harness - See Part Catalog  
 Description: 6-Way M 1.5 MX Series, Sealed( BK)

#### Terminal Part Information

Terminal Type ID	Terminated Lead	Diagnostic Test Probe	Terminal Removal Tool
I	Not required	J-35616-2A (GY)	No Tool Required
II	Not required	J-35616-3 (GY)	No Tool Required

### X420B Chassis Wiring Harness to Chassis Rear Wiring Harness Extension Harness (Z45)

Pin	Size	Color	Circuit	Terminal Type ID	Option	Function	Pin	Size	Color	Circuit	Terminal Type ID	Option
1	0.75	BU / GY	1114	I	—	Left Rear Shock Absorber Actuator Control	1	0.75	BU / GY	1114	II	—
2	0.5	GN / YE	1616	I	—	Rear Brake Pad Wear Sensor Signal	2	0.75	GN / YE	1616	II	—
3	0.75	GY / BK	7253	I	G94	Rear Differential Lock Actuator Low Control	3	0.75	GY / BK	7253	II	G94
	0.75	BN / GN	1118	I	Z45	Right Rear Shock Absorber Actuator Control				1118		
4	0.75	GN / VT	1115	I	—	Left Rear Shock Absorber Actuator Control	4	0.75	GN / VT	1115	II	—
5	0.5	BK / WH	1951	I	—	Signal Ground	5	0.75	BK / WH	1751	II	—

**6-874 Electrical Component and Inline Harness Connector End Views**

**X420B Chassis Wiring Harness to Chassis Rear Wiring Harness Extension Harness (Z45)  
(cont'd)**

Pin	Size	Color	Circuit	Terminal Type ID	Option	Function	Pin	Size	Color	Circuit	Terminal Type ID	Option
6	0.75	VT / BN	7258	I	G94	Rear Differential Lock Actuator Control	6	0.75	VT / BN	7258	II	G94
	0.75	GN / GY	1119	I	Z45	Right Rear Shock Absorber Actuator Control		0.75	GN / GY	1119	II	Z45



### X424 Body Wiring Harness to Chassis Wiring Harness

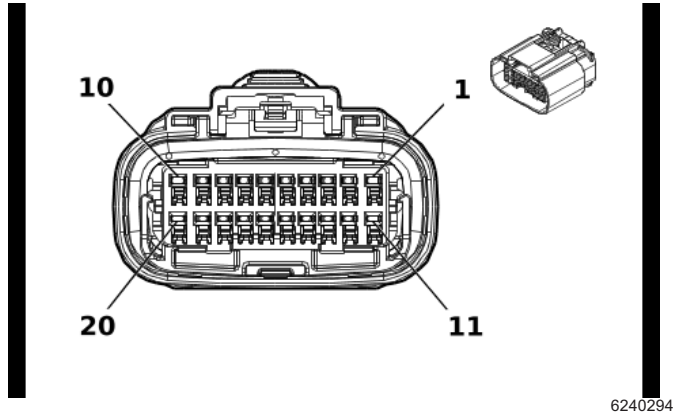

#### Connector Part Information

Harness Type: Body Wiring Harness  
 OEM Connector: 35465658  
 Service Connector: 86579559  
 Description: 20-Way F 1.2 MCON-CB Series, Sealed( BK)

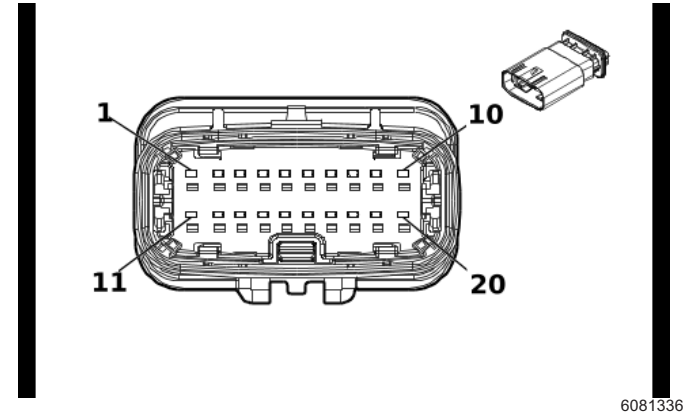

#### Connector Part Information

Harness Type: Chassis Wiring Harness  
 OEM Connector: 35465720  
 Service Connector: 85625526  
 Description: 20-Way M 1.2 MCON-CB Series, Sealed( BK)

#### Terminal Part Information

Terminal Type ID	Terminated Lead	Diagnostic Test Probe	Terminal Removal Tool
I	19370818	J-35616-12 (BU)	J-38125-215A
II	19371217	J-35616-12 (BU)	J-38125-553
III	84867140	J-35616-13 (BU)	J-38125-215A
IV	84867141	J-35616-13 (BU)	J-38125-215A

### X424 Body Wiring Harness to Chassis Wiring Harness

Pin	Size	Color	Circuit	Terminal Type ID	Option	Function	Pin	Size	Color	Circuit	Terminal Type ID	Option
1	1	VT	7725	II	—	Minor Endgate Motor Control	1	1	VT	7725	IV	—
2	0.5	WH	4986	I	—	AUTOSAR CAN Bus [-] 1 Serial Data	2	0.5	WH	4986	III	—
3	0.5	WH	4100	I	—	AUTOSAR CAN Bus [-] 4 Serial Data	3	0.5	WH	4100	III	—
4	0.5	BU / VT	4101	I	—	AUTOSAR CAN Bus [+] 4 Serial Data	4	0.5	BU / VT	4101	III	—
5	0.5	WH / GY	4104	I	—	AUTOSAR CAN Bus [-] 8 Serial Data	5	0.5	WH / GY	4104	III	—
6	0.5	BU / GY	4105	I	—	AUTOSAR CAN Bus [+] 8 Serial Data	6	0.5	BU / GY	4105	III	—
7	0.5	WH / GY	4104	I	—	AUTOSAR CAN Bus [-] 8 Serial Data	7	0.5	WH / GY	4104	III	—
8	0.5	BU / GY	4105	I	—	AUTOSAR CAN Bus [+] 8 Serial Data	8	0.5	BU / GY	4105	III	—

**6-876 Electrical Component and Inline Harness Connector End Views**

**X424 Body Wiring Harness to Chassis Wiring Harness (cont'd)**

Pin	Size	Color	Circuit	Terminal Type ID	Option	Function	Pin	Size	Color	Circuit	Terminal Type ID	Option
9	0.35	YE	1144	I	—	Endgate Release Switch Discrete Signal Exterior	9	0.5	YE	1144	III	—
10	1	GN	1299	II	—	Major Endgate Motor Control	10	1	GN	1299	IV	—
11	—	—	—	—	—	Not Occupied	11	—	—	—	—	—
12	0.5	BU	4987	I	—	AUTOSAR CAN Bus [+] 1 Serial Data	12	0.5	BU	4987	III	—
13	0.35	YE / BU	7295	I	—	Left Minor Endgate Ajar Signal	13	0.75	YE / BU	7295	III	—
14	0.5	BU / GY	4054	I	—	Private Serial Data Powertrain CAN Bus [-] Serial Data	14	0.5	BU / GY	4054	III	—
15	0.5	WH	4055	I	—	Private Serial Data Powertrain CAN Bus [+] Serial Data	15	0.5	WH	4055	III	—
16	—	—	—	—	—	Not Occupied	16	—	—	—	—	—
17	0.5	WH	4986	I	—	AUTOSAR CAN Bus [-] 1 Serial Data	17	0.5	WH	4986	III	—
18	0.5	BU	4987	I	—	AUTOSAR CAN Bus [+] 1 Serial Data	18	0.5	BU	4987	III	—
19	—	—	—	—	—	Not Occupied	19	—	—	—	—	—
20	1	YE / BK	7730	II	—	Major Endgate Motor Low Reference	20	1	YE / BK	7730	IV	—

**X500 Front Side Door Door Wiring Harness - Driver to Body Wiring Harness**

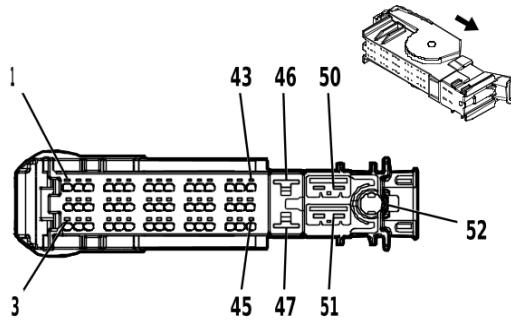

4992530

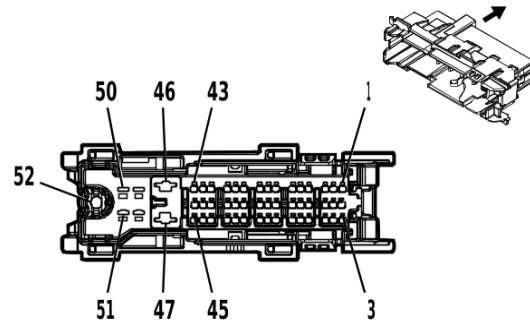

4993484

**Connector Part Information**

Harness Type: Front Side Door Door Wiring Harness - Driver  
 OEM Connector: 6098-8365  
 Service Connector: Service by Harness - See Part Catalog  
 Description: 52-Way F 1.2, 2.8, 6.3, Coaxial Series( BK)

**Connector Part Information**

Harness Type: Body Wiring Harness  
 OEM Connector: 35190453  
 Service Connector: 13527236  
 Description: 52-Way M 1.2, 2.8, 6.3, Coaxial Series( BK)

**Terminal Part Information**

Terminal Type ID	Terminated Lead	Diagnostic Test Probe	Terminal Removal Tool
I	Not required	J-35616-16 (L-GN)	No Tool Required
II	Not required	J-35616-42 (RD)	No Tool Required
III	Not required	No Tool Required	No Tool Required
IV	19301536	J-35616-43 (RD)	J-38125-11A
V	84616651	J-35616-13 (BU)	J-38125-215A
VI	Service by Cable	No Tool Required	J-38125-12A

**X500 Front Side Door Door Wiring Harness - Driver to Body Wiring Harness**

Pin	Size	Color	Circuit	Terminal Type ID	Option	Function	Pin	Size	Color	Circuit	Terminal Type ID	Option
1	—	—	—	—	—	Not Occu- pied	1	—	—	—	—	—
2	0.5	RD / BU	1240	I	—	Battery Posi- tive Voltage	2	0.5	RD / BU	1240	V	—
3- 5	—	—	—	—	—	Not Occu- pied	3- 5	—	—	—	—	—
6	0.5	BK / OG	6628	I	—	Left Front Side Impact Sensor Low Reference	6	0.5	BK / OG	6628	V	—
7	0.75	BN / BU	118	I	—	Left Front Speaker [-] Control 1	7	0.75	BN / BU	118	V	—
8	0.75	BU	201	I	—	Left Front Speaker 1 [+] Control	8	0.75	BU	201	V	—
9	0.5	OG / GN	2132	I	—	Left Front Side Impact Sensor Sig- nal	9	0.5	OG / GN	2132	V	—
10	—	—	—	—	—	Not Occu- pied	10	—	—	—	—	—

**6-878 Electrical Component and Inline Harness Connector End Views**

**X500 Front Side Door Door Wiring Harness - Driver to Body Wiring Harness (cont'd)**

Pin	Size	Color	Circuit	Terminal Type ID	Option	Function	Pin	Size	Color	Circuit	Terminal Type ID	Option
11	0.5	VT	4301	I	—	Passive Entry Left Antenna Signal High	11	0.35	VT	4301	V	—
12	0.5	VT / GY	4302	I	—	Passive Entry Left Antenna Signal Low	12	0.35	VT / WH	4302	V	—
13	0.5	VT / GY	126	I	—	Left Front Door Open Switch Signal	13	0.35	VT / GY	126	V	—
14	0.5	YE / WH	1690	I	—	Mirror Dimming Signal	14	0.35	YE / WH	1690	V	—
15	0.5	BK / YE	1691	I	—	Automatic Day/Night Mirror Low Reference	15	0.35	BK / YE	1691	V	—
16	0.5	WH / GY	2114	I	—	Left Turn Signal Lamp Control 2	16	0.35	WH / GY	2114	V	—
17	0.5	BU	2675	I	—	Left Front Exterior Door Handle Switch Unlock Signal	17	0.35	BU	2675	V	—
18	0.75	WH	2679	I	—	Lock Actuators Unlock Control 1	18	0.75	WH	2679	V	—
19	0.75	GY	2681	I	—	Left Front Door Lock Actuator Lock Control	19	0.75	GY	2681	V	—
20 - 22	—	—	—	—	—	Not Occupied	20 - 22	—	—	—	—	—
23	0.5	WH / GN	5966	I	—	Approach Lamp Control	23	0.5	WH / GN	5966	V	—
24	—	—	—	—	—	Not Occupied	24	—	—	—	—	—
25	0.5	BU / GN	614	I	—	Seat Memory Switch Set Signal	25	0.35	BU / GN	614	V	—
26	0.5	BU / YE	7761	I	—	Backup Illumination Lamp Control	26	0.35	BU / YE	7761	V	—
27	0.5	YE	6817	I	—	LED Backlight Dimming Control 1	27	0.5	YE	6817	V	—
28	—	—	—	—	—	Not Occupied	28	—	—	—	—	—
29	0.5	GN / YE	6134	I	—	Body Control Module LIN Bus 3	29	0.35	GN / YE	6134	V	—
30	0.5	BN / GN	4246	I	—	Identification Lamp Control	30	0.5	BN / GN	4246	V	—
31	0.5	BK / WH	1551	I	—	Ground Signal Ground	31	0.5	BK / WH	1550 1551	V	—

**X500 Front Side Door Door Wiring Harness - Driver to Body Wiring Harness (cont'd)**

Pin	Size	Color	Circuit	Terminal Type ID	Option	Function	Pin	Size	Color	Circuit	Terminal Type ID	Option
32	0.5	YE / GY	2933	I	—	Task Lamp Control Left	32	0.35	YE / GY	2933	V	—
33	0.5	WH	615	I	—	Seat Memory Switch Signal 1	33	0.35	WH	615	V	—
34 - 45	—	—	—	—	—	Not Occupied	34 - 45	—	—	—	—	—
46	2.5	RD / GY	3540	II	—	Battery Positive Voltage	46	2.5	RD / GY	3540	IV	—
47	2.5	BK	1550	II	—	Ground	47	2.5	BK	1550	IV	—
48 - 51	—	—	—	—	—	Not Occupied	48 - 51	—	—	—	—	—
52	0	—	4725	III	—	Left Sideview Camera LVDS (Low Voltage Differential Signaling) Co-axial Signal	52	0	—	4725	VI	—

**X505 Front Side Door Door Wiring Harness - Driver to Front Side Door Door Lock Door Wiring Harness - Driver**

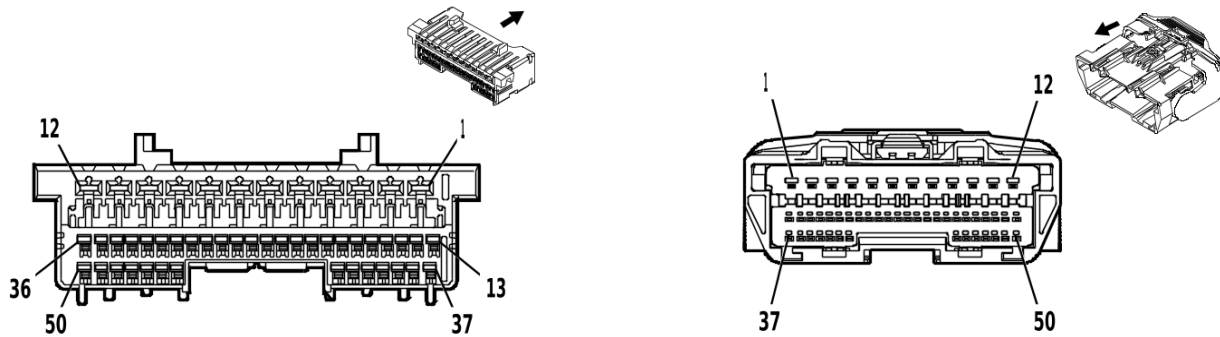

4997556

5022037

**Connector Part Information**

Harness Type: Front Side Door Door Wiring Harness - Driver  
 OEM Connector: 35283943  
 Service Connector: Service by Harness - See Part Catalog  
 Description: 50-Way F 1.2, 2.8 OCS Series( BK)

**Connector Part Information**

Harness Type: Front Side Door Door Lock Door Wiring Harness - Driver  
 OEM Connector: 33390111  
 Service Connector: Service by Harness - See Part Catalog  
 Description: 50-Way M 1.2, 2.8 OCS Series( BK)

**Terminal Part Information**

Terminal Type ID	Terminated Lead	Diagnostic Test Probe	Terminal Removal Tool
I	Not required	J-35616-16 (L-GN)	No Tool Required
II	Not required	J-35616-4A (PU)	No Tool Required
III	Not required	J-35616-17 (L-GN)	No Tool Required
IV	Not required	J-35616-5 (PU)	No Tool Required

**X505 Front Side Door Door Wiring Harness - Driver to Front Side Door Door Lock Door Wiring Harness - Driver**

Pin	Size	Color	Circuit	Terminal Type ID	Option	Function	Pin	Size	Color	Circuit	Terminal Type ID	Option
1	0.5	RD / BU	1240	II	—	Battery Positive Voltage	1	0.5	RD / BU	1240	IV	—
2	0.5	GY / YE	1760	II	—	Left Side Object Detection LED Control	2	0.35	GY / YE	1760	IV	—
3	—	—	—	—	—	Not Occupied	3	—	—	—	—	—
4	0.5	GY / GN	2763	II	—	Window Switch Left Front Up Signal	4	0.5	GY / GN	2763	IV	—
5	—	—	—	—	—	Not Occupied	5	—	—	—	—	—
6	0.5	WH / BN	2764	II	—	Window Switch Left Front Down Signal	6	0.5	WH / BN	2764	IV	—
7	—	—	—	—	—	Not Occupied	7	—	—	—	—	—

**X505 Front Side Door Door Wiring Harness - Driver to Front Side Door Door Lock Door Wiring Harness - Driver (cont'd)**

Pin	Size	Color	Circuit	Terminal Type ID	Option	Function	Pin	Size	Color	Circuit	Terminal Type ID	Option
8	0.5	GN	2766	II	—	Power Window Switch Left Front Express Signal	8	0.5	GN	2766	IV	—
9-11	—	—	—	—	—	Not Occupied	9-11	—	—	—	—	—
12	0.5	GY / WH	2785	II	—	Left Front Mirror Motor Fold Out Control	12	0.5	GY / WH	2785	IV	—
13	0.5	WH / GN	2786	I	—	Left Front Mirror Motor Fold In Control	13	0.5	WH / GN	2786	III	—
14	0.5	GY / BN	2787	I	—	Left Front Mirror Position Sensor Up [+] Down [-] Signal	14	0.5	GY / BN	2787	III	—
15	0.5	VT / BU	2788	I	—	Left Front Mirror Motor Up [+] Down [-] Control	15	0.5	VT / BU	2788	III	—
16	0.5	YE / BN	2789	I	—	Left Front Mirror Motor Common Control	16	0.5	YE / BN	2789	III	—
17	0.5	BN / BK	2790	I	—	Left Front Mirror Motor Right [+] Left [-] Control	17	0.5	BN / BK	2790	III	—
18	0.5	VT / RD	2791	I	—	Left Front Mirror Position Sensor High Reference	18	0.5	VT / RD	2791	III	—
19	0.5	WH / YE	2792	I	—	Left Front Mirror Position Sensor Left [-] Right [+] Signal	19	0.5	WH / YE	2792	III	—
20	0.5	WH	606	I	—	Left Outside Rearview Mirror Heater Control	20	0.5	WH	606	III	—
21	0.5	GN / YE	6134	I	—	Body Control Module LIN Bus 3	21	0.5	GN / YE	6134	III	—
22	0.5	BU / GN	614	I	—	Seat Memory Switch Set Signal	22	0.5	BU / GN	614	III	—
23	0.5	WH	615	I	—	Seat Memory Switch Signal 1	23	0.5	WH	615	III	—
24	0.5	BK / BN	673	I	—	Left Outside Rearview Mirror Position Sensor Low Reference	24	0.5	BK / BN	673	III	—

**6-882 Electrical Component and Inline Harness Connector End Views**

**X505 Front Side Door Door Wiring Harness - Driver to Front Side Door Door Lock Door Wiring Harness - Driver (cont'd)**

Pin	Size	Color	Circuit	Terminal Type ID	Option	Function	Pin	Size	Color	Circuit	Terminal Type ID	Option
25	0.5	YE	6817	I	—	LED Back-light Dimming Control 1	25	0.5	YE	6817	III	—
26	—	—	—	—	—	Not Occupied	26	—	—	—	—	—
27	0.5	BK	1550	I	—	Ground	27	0.5	BK	1550	III	—
28	0.5	BK / WH	1551	I	—	Signal Ground	28	0.5	BK / WH	1551	III	—
29	0.5	WH / VT	4258	I	—	Left Front Door Lock Status Signal	29	0.5	WH / VT	4258	III	—
30 - 50	—	—	—	—	—	Not Occupied	30 - 50	—	—	—	—	—



**X600 Front Side Door Door Wiring Harness - Passenger to Body Wiring Harness - Double Cab / Crew Cab**

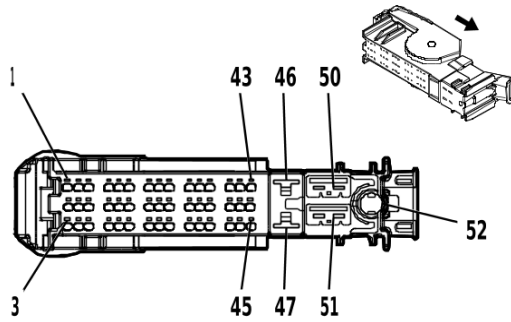

4992530

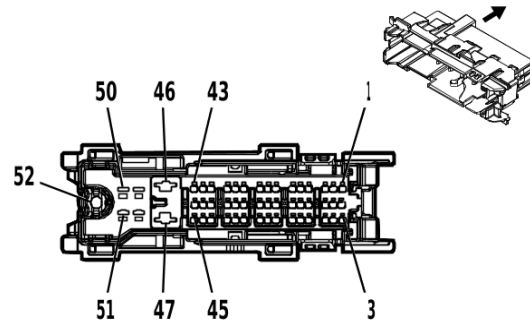

4993484

**Connector Part Information**

Harness Type: Front Side Door Door Wiring Harness - Passenger  
 OEM Connector: 35077349  
 Service Connector: Service by Harness - See Part Catalog  
 Description: 52-Way F 1.2, 2.8, 6.3, Coaxial Series( BK)

**Connector Part Information**

Harness Type: Body Wiring Harness  
 OEM Connector: 35190453  
 Service Connector: 13527236  
 Description: 52-Way M 1.2, 2.8, 6.3, Coaxial Series( BK)

**Terminal Part Information**

Terminal Type ID	Terminated Lead	Diagnostic Test Probe	Terminal Removal Tool
I	Not required	J-35616-16 (L-GN)	No Tool Required
II	Not required	J-35616-42 (RD)	No Tool Required
III	Not required	No Tool Required	No Tool Required
IV	19301536	J-35616-43 (RD)	J-38125-11A
V	84616651	J-35616-13 (BU)	J-38125-215A
VI	Service by Cable	No Tool Required	J-38125-12A

**X600 Front Side Door Door Wiring Harness - Passenger to Body Wiring Harness - Double Cab / Crew Cab**

Pin	Size	Color	Circuit	Terminal Type ID	Option	Function	Pin	Size	Color	Circuit	Terminal Type ID	Option
1-4	—	—	—	—	—	Not Occupied	1-4	—	—	—	—	—
5	0.75	YE	200	I	—	Right Front Speaker 1 [+] Control	5	0.75	YE	200	V	—
6	0.75	YE / BK	117	I	—	Right Front Speaker [-] Control 1	6	0.75	YE / BK	117	V	—
7	—	—	—	—	—	Not Occupied	7	—	—	—	—	—
8	0.5	BN / OG	2134	I	—	Right Front Side Impact Sensor Signal	8	0.5	BN / OG	2134	V	—
9	0.5	BK / OG	6629	I	—	Right Front Side Impact Sensor Low Reference	9	0.5	BK / OG	6629	V	—

**6-884 Electrical Component and Inline Harness Connector End Views**

**X600 Front Side Door Door Wiring Harness - Passenger to Body Wiring Harness - Double Cab / Crew Cab (cont'd)**

Pin	Size	Color	Circuit	Terminal Type ID	Option	Function	Pin	Size	Color	Circuit	Terminal Type ID	Option
10	0.5	GN / YE	4303	I	—	Passive Entry Right Antenna Signal High	10	0.35	GN / YE	4303	V	—
11	0.5	GN / BK	4304	I	—	Passive Entry Right Antenna Signal Low	11	0.35	GN / BK	4304	V	—
12	—	—	—	—	—	Not Occupied	12	—	—	—	—	—
13	0.5	GN / GY	2115	I	—	Right Turn Signal Lamp Control 2	13	0.35	GN / GY	2115	V	—
14	0.5	GY / VT	2676	I	—	Right Front Door Exterior Switch Unlock Signal	14	0.35	GY / VT	2676	V	—
15	0.75	GY / BK	2680	I	—	Lock Actuators Unlock Control 2	15	0.75	GY / BK	2680	V	—
16	0.75	YE / GN	2682	I	—	Right Front Door Lock Actuator Lock Control	16	0.75	YE / GN	2682	V	—
17 - 19	—	—	—	—	—	Not Occupied	17 - 19	—	—	—	—	—
20	0.5	WH / GN	5966	I	—	Approach Lamp Control	20	0.5	WH / GN	5966	V	—
21	—	—	—	—	—	Not Occupied	21	—	—	—	—	—
22	0.5	BK / GY	626	I	—	Engine Control Vehicle Sensors Low Reference 1	22	0.5	BK / GY	626	V	—
23	0.5	BU / GY	636	I	—	Ambient Air Temperature Sensor Signal	23	0.5	BU / GY	636	V	—
24	0.5	YE	6817	I	—	LED Backlight Dimming Control 1	24	0.5	YE	6817	V	—
25	—	—	—	—	—	Not Occupied	25	—	—	—	—	—
26	0.5	BU / YE	7761	I	—	Backup Illumination Lamp Control	26	0.35	BU / YE	7761	V	—
27	—	—	—	—	—	Not Occupied	27	—	—	—	—	—
28	0.5	BK / WH	1451	I	—	Signal Ground	28	0.75	BK / WH	1451	V	—
29	0.5	GN / YE	6134	I	—	Body Control Module LIN Bus 3	29	0.35	GN / YE	6134	V	—
30	0.5	YE / WH	2934	I	—	Task Lamp Control Right	30	0.35	YE / WH	2934	V	—

**X600 Front Side Door Door Wiring Harness - Passenger to Body Wiring Harness - Double Cab / Crew Cab (cont'd)**

Pin	Size	Color	Circuit	Terminal Type ID	Option	Function	Pin	Size	Color	Circuit	Terminal Type ID	Option
31	0.5	BN / GN	4246	I	—	Identification Lamp Control	31	0.5	BN / GN	4246	V	—
32 - 45	—	—	—	—	—	Not Occupied	32 - 45	—	—	—	—	—
46	2.5	RD / BN	4240	II	—	Battery Positive Voltage	46	2.5	RD / BN	4240	IV	—
47	2.5	BK	1350	II	—	Ground	47	2.5	BK	1350	IV	—
48 - 51	—	—	—	—	—	Not Occupied	48 - 51	—	—	—	—	—
52	0	—	4724	III	—	Right Side-view Camera LVDS (Low Voltage Differential Signaling) Co-axial Signal	52	0	—	4724	VI	—

**X600 Front Side Door Door Wiring Harness - Passenger to Body Wiring Harness - Regular Cab**

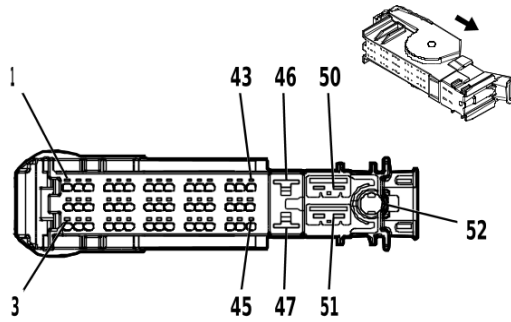

4992530

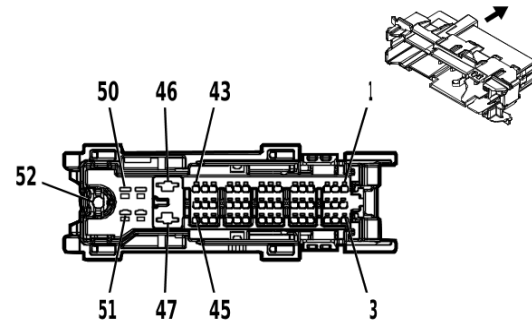

4993484

**Connector Part Information**

Harness Type: Front Side Door Door Wiring Harness - Passenger  
 OEM Connector: 6098-8365  
 Service Connector: Service by Harness - See Part Catalog  
 Description: 52-Way F 1.2, 2.8, 6.3, Coaxial Series( BK)

**Connector Part Information**

Harness Type: Body Wiring Harness  
 OEM Connector: 35190453  
 Service Connector: 13527236  
 Description: 52-Way M 1.2, 2.8, 6.3, Coaxial Series( BK)

**Terminal Part Information**

Terminal Type ID	Terminated Lead	Diagnostic Test Probe	Terminal Removal Tool
I	Not required	J-35616-16 (L-GN)	No Tool Required
II	Not required	J-35616-42 (RD)	No Tool Required
III	19301536	J-35616-43 (RD)	J-38125-11A
IV	84616651	J-35616-13 (BU)	J-38125-215A

**X600 Front Side Door Door Wiring Harness - Passenger to Body Wiring Harness - Regular Cab**

Pin	Size	Color	Circuit	Terminal Type ID	Option	Function	Pin	Size	Color	Circuit	Terminal Type ID	Option
1-4	—	—	—	—	—	Not Occupied	1-4	—	—	—	—	—
5	0.75	YE	200	I	—	Right Front Speaker 1 [+] Control	5	0.75	YE	200	IV	—
6	0.75	YE / BK	117	I	—	Right Front Speaker [-] Control 1	6	0.75	YE / BK	117	IV	—
7	—	—	—	—	—	Not Occupied	7	—	—	—	—	—
8	0.5	BN / OG	2134	I	—	Right Front Side Impact Sensor Signal	8	0.5	BN / OG	2134	IV	—
9	0.5	BK / OG	6629	I	—	Right Front Side Impact Sensor Low Reference	9	0.5	BK / OG	6629	IV	—
10	0.5	GN / YE	4303	I	—	Passive Entry Right Antenna Signal High	10	0.35	GN / YE	4303	IV	—

**X600 Front Side Door Door Wiring Harness - Passenger to Body Wiring Harness - Regular Cab (cont'd)**

Pin	Size	Color	Circuit	Terminal Type ID	Option	Function	Pin	Size	Color	Circuit	Terminal Type ID	Option
11	0.5	GN / BK	4304	I	—	Passive Entry Right Antenna Signal Low	11	0.35	GN / BK	4304	IV	—
12	—	—	—	—	—	Not Occupied	12	—	—	—	—	—
13	0.5	GN / GY	2115	I	—	Right Turn Signal Lamp Control 2	13	0.35	GN / GY	2115	IV	—
14	0.5	GY / VT	2676	I	—	Right Front Door Exterior Switch Unlock Signal	14	0.35	GY / VT	2676	IV	—
15	0.75	GY / BK	2680	I	—	Lock Actuators Unlock Control 2	15	0.75	GY / BK	2680	IV	—
16	0.75	YE / GN	2682	I	—	Right Front Door Lock Actuator Lock Control	16	0.75	YE / GN	2682	IV	—
17 - 19	—	—	—	—	—	Not Occupied	17 - 19	—	—	—	—	—
20	0.5	WH / GN	5966	I	—	Approach Lamp Control	20	0.5	WH / GN	5966	IV	—
21	—	—	—	—	—	Not Occupied	21	—	—	—	—	—
22	0.5	BK / GY	626	I	—	Engine Control Vehicle Sensors Low Reference 1	22	0.5	BK / GY	626	IV	—
23	0.5	BU / GY	636	I	—	Ambient Air Temperature Sensor Signal	23	0.5	BU / GY	636	IV	—
24	—	—	—	—	—	LED Backlight Dimming Control 1	24	0.5	YE	6817	IV	—
25	—	—	—	—	—	Not Occupied	25	—	—	—	—	—
26	0.5	BU / YE	7761	I	—	Backup Illumination Lamp Control	26	0.35	BU / YE	7761	IV	—
27	—	—	—	—	—	Not Occupied	27	—	—	—	—	—
28	0.5	BK / WH	1451	I	—	Signal Ground	28	0.75	BK / WH	1451	IV	—
29	0.5	GN / YE	6134	I	—	Body Control Module LIN Bus 3	29	0.35	GN / YE	6134	IV	—
30	0.5	YE / WH	2934	I	—	Task Lamp Control Right	30	0.35	YE / WH	2934	IV	—
31	0.5	BN / GN	4246	I	—	Identification Lamp Control	31	0.5	BN / GN	4246	IV	—
32 - 45	—	—	—	—	—	Not Occupied	32 - 45	—	—	—	—	—

**6-888 Electrical Component and Inline Harness Connector End Views****X600 Front Side Door Door Wiring Harness - Passenger to Body Wiring Harness - Regular Cab (cont'd)**

Pin	Size	Color	Circuit	Terminal Type ID	Option	Function	Pin	Size	Color	Circuit	Terminal Type ID	Option
46	2.5	RD / BN	4240	II	—	Battery Positive Voltage	46	2.5	RD / BN	4240	III	—
47	2.5	BK	1350	II	—	Ground	47	2.5	BK	1350	III	—
48 - 52	—	—	—	—	—	Not Occupied	48 - 52	—	—	—	—	—

**X605 Front Side Door Door Wiring Harness - Passenger to Front Side Door Door Lock Door Wiring Harness - Passenger**

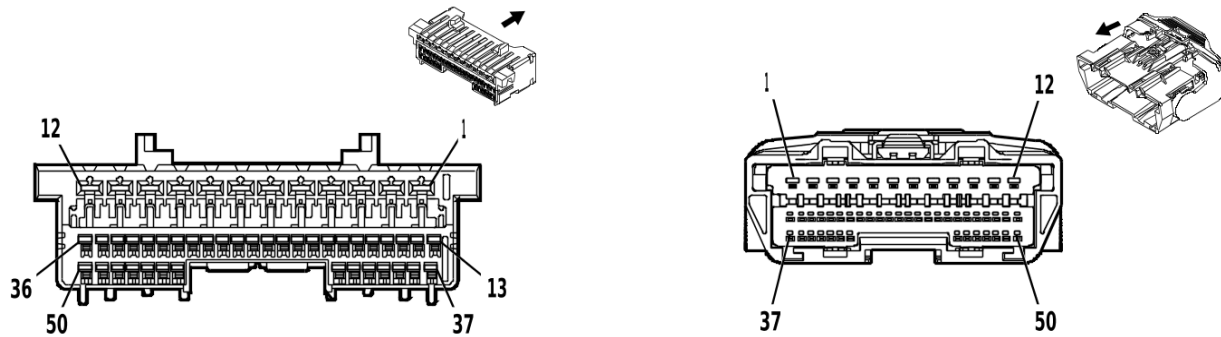

4997556

5022037

**Connector Part Information**

Harness Type: Front Side Door Door Wiring Harness - Passenger  
 OEM Connector: 35283943  
 Service Connector: Service by Harness - See Part Catalog  
 Description: 50-Way F 1.2, 2.8 OCS Series( BK)

**Connector Part Information**

Harness Type: Front Side Door Door Lock Door Wiring Harness - Passenger  
 OEM Connector: 33390111  
 Service Connector: Service by Harness - See Part Catalog  
 Description: 50-Way M 1.2, 2.8 OCS Series( BK)

**Terminal Part Information**

Terminal Type ID	Terminated Lead	Diagnostic Test Probe	Terminal Removal Tool
I	Not required	J-35616-16 (L-GN)	No Tool Required
II	Not required	J-35616-4A (PU)	No Tool Required
III	Not required	J-35616-17 (L-GN)	No Tool Required
IV	Not required	J-35616-5 (PU)	No Tool Required

**X605 Front Side Door Door Wiring Harness - Passenger to Front Side Door Door Lock Door Wiring Harness - Passenger**

Pin	Size	Color	Circuit	Terminal Type ID	Option	Function	Pin	Size	Color	Circuit	Terminal Type ID	Option
1	2.5	RD / BN	4240	II	—	Battery Positive Voltage	1	2.5	RD / BN	4240	IV	—
2	0.5	GN	1184	II	—	Window Switch Right Front Up Signal	2	0.5	GN	1184	IV	—
3	0.5	GY	1761	II	—	Right Side Object Detection LED Control	3	0.35	GY	1761	IV	—
4	—	—	—	—	—	Not Occupied	4	—	—	—	—	—
5	0.5	VT / GY	2765	II	—	Window Switch Right Front Express Signal	5	0.5	VT / GY	2765	IV	—
6 - 7	—	—	—	—	—	Not Occupied	6 - 7	—	—	—	—	—
8	0.5	YE / WH	2793	II	—	Right Front Mirror Motor Fold Out Control	8	0.5	YE / WH	2793	IV	—

**6-890 Electrical Component and Inline Harness Connector End Views**

**X605 Front Side Door Door Wiring Harness - Passenger to Front Side Door Door Lock Door Wiring Harness - Passenger (cont'd)**

Pin	Size	Color	Circuit	Terminal Type ID	Option	Function	Pin	Size	Color	Circuit	Terminal Type ID	Option
9	0.5	BU / GY	2794	II	—	Right Front Mirror Motor Fold In Control	9	0.5	BU / GY	2794	IV	—
10	2.5	BK	1350	II	—	Ground	10	2.5	BK	1350	IV	—
11	2	GN / GY	666	II	—	Right Front Window Motor Up Control	11	2.5	GN / GY	666	IV	—
12	2	YE / BU	667	II	—	Right Front Window Motor Down Control	12	2.5	YE / BU	667	IV	—
13	0.5	GN / BK	2798	I	—	Right Front Mirror Motor Right [+] Left [-] Control	13	0.5	GN / BK	2798	III	—
14	0.5	YE / RD	2799	I	—	Right Front Mirror Position Sensor High Reference	14	0.5	YE / RD	2799	III	—
15	0.5	VT / WH	2800	I	—	Right Front Mirror Position Sensor Left [-] Right [+] Signal	15	0.5	VT / WH	2800	III	—
16	0.5	BN	5295	I	—	Window Switch Right Front Down Signal	16	0.5	BN	5295	III	—
17	0.5	BN / VT	607	I	—	Right Outside Rear-view Mirror Heater Control	17	0.5	BN / VT	607	III	—
18	0.5	GN / YE	6134	I	—	Body Control Module LIN Bus 3	18	0.5	GN / YE	6134	III	—
19 - 20	—	—	—	—	—	Not Occupied	19 - 20	—	—	—	—	—
21	0.5	BK / GN	675	I	—	Right Outside Rear-view Mirror Position Sensor Low Reference	21	0.5	BK / GN	675	III	—
22	0.5	YE	6817	I	—	LED Backlight Dimming Control 1	22	0.5	YE	6817	III	—
23 - 46	—	—	—	—	—	Not Occupied	23 - 46	—	—	—	—	—
47	0.5	GY	746	I	—	Right Front Door Ajar Switch Signal	47	0.5	GY	746	III	—



**X605 Front Side Door Door Wiring Harness - Passenger to Front Side Door Door Lock  
Door Wiring Harness - Passenger (cont'd)**

Pin	Size	Color	Circuit	Terminal Type ID	Option	Function	Pin	Size	Color	Circuit	Terminal Type ID	Option
48	0.5	BU / YE	2795	I	—	Right Front Mirror Position Sensor Up [+] Down [-] Signal	48	0.5	BU / YE	2795	III	—
49	0.5	YE / VT	2796	I	—	Right Front Mirror Motor Up [+] Down [-] Control	49	0.5	YE / VT	2796	III	—
50	0.5	WH	2797	I	—	Right Front Mirror Motor Common Control	50	0.5	WH	2797	III	—

**X618A Engine Wiring Harness to Active Grille Air Shutter Actuator Wiring Harness (VTI / WMI)**

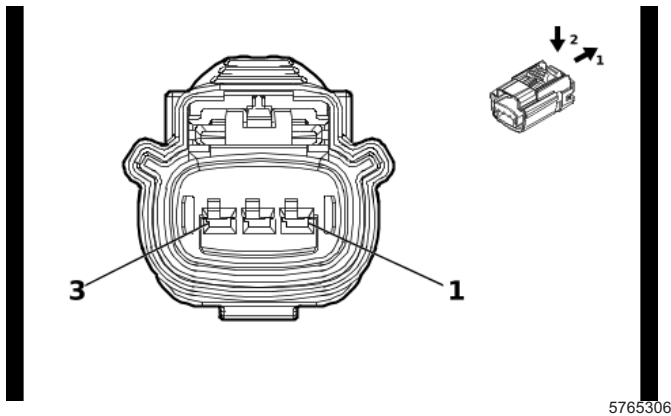

5765306

**Connector Part Information**

Harness Type: Engine Wiring Harness  
 OEM Connector: 15514762  
 Service Connector: 85535179  
 Description: 3-Way F 1.5 YESC Series, Sealed( BK)

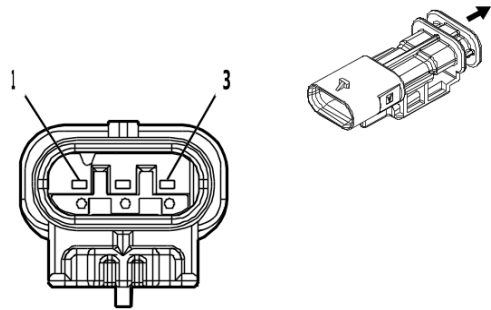

5068799

**Connector Part Information**

Harness Type: Active Grille Air Shutter Actuator Wiring Harness  
 OEM Connector: Not Available  
 Service Connector: Service by Harness - See Part Catalog  
 Description: 3-Way M ( BK)

**Terminal Part Information**

Terminal Type ID	Terminated Lead	Diagnostic Test Probe	Terminal Removal Tool
I	Not required	J-35616-2A (GY)	No Tool Required
II	Not required	No Tool Required	No Tool Required

**X618A Engine Wiring Harness to Active Grille Air Shutter Actuator Wiring Harness (VTI / WMI)**

Pin	Size	Color	Circuit	Terminal Type ID	Option	Function	Pin	Size	Color	Circuit	Terminal Type ID	Option
1	0.5	VT / BU	5705	I	—	Powertrain Main Relay Control	1	0.5	VT / BU	5705	II	—
2	0.5	GN / VT	4621	I	—	Engine Control Module LIN Bus 1	2	0.5	GN / VT	4621	II	—
3	0.5	BK	450	I	L3B	Ground	3	0.5	BK	450	II	L3B
	1	BK	450	I	L84/ L87	Ground						L84/ L87
	0.5	BK	6550	I	LZ0	Ground						LZ0

**X618L Active Grille Air Shutter Wiring Harness to Active Grille Air Shutter Jumper Wiring Harness (WMI)**

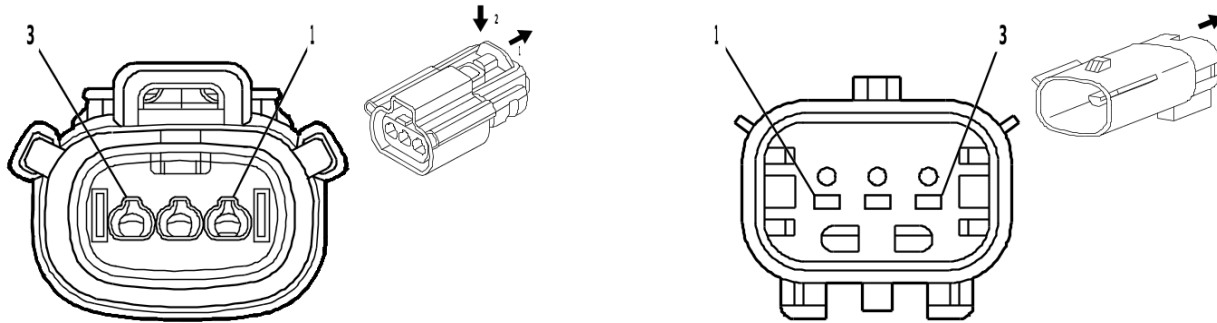

5095610

1870038

**Connector Part Information**

Harness Type: Active Grille Air Shutter Wiring Harness  
 OEM Connector: 13526813  
 Service Connector: Service by Harness - See Part Catalog  
 Description: 3-Way F 1.5 Series, Sealed( BK)

**Connector Part Information**

Harness Type: Active Grille Air Shutter Jumper Wiring Harness  
 OEM Connector: 13526822  
 Service Connector: Service by Harness - See Part Catalog  
 Description: 3-Way M 1.5 MX Series, Sealed( BK)

**Terminal Part Information**

Terminal Type ID	Terminated Lead	Diagnostic Test Probe	Terminal Removal Tool
I	Not required	J-35616-3 (GY)	No Tool Required
II	Not required	J-35616-14 (GN)	No Tool Required

**X618L Active Grille Air Shutter Wiring Harness to Active Grille Air Shutter Jumper Wiring Harness (WMI)**

Pin	Size	Color	Circuit	Terminal Type ID	Option	Function	Pin	Size	Color	Circuit	Terminal Type ID	Option
1	0.5	VT / BU	5705	I	—	Powertrain Main Relay Control	1	0.5	VT / BU	5705	II	—
2	0.5	GN / VT	4621	I	—	Engine Control Module LIN Bus 1	2	0.5	GN / VT	4621	II	—
3	0.5	BK	450	I	L3B/ L84/ L87	Ground	3	0.5	BK	450	II	L3B/ L84/ L87
	0.5	BK	6550	I	LZ0	Ground		0.5	BK	6550	II	LZ0

**X630 Auxiliary Fuse Block Wiring Harness to Auxiliary Fuse Block Wiring Harness**

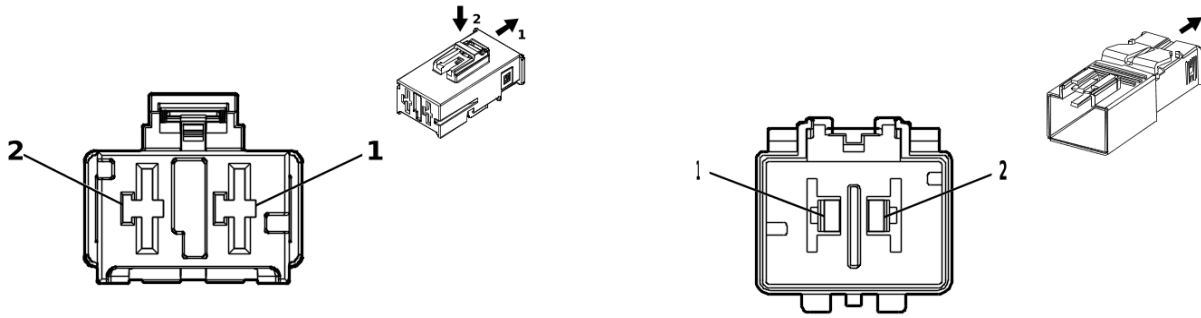

5187955

4891120

**Connector Part Information**

Harness Type: Auxiliary Fuse Block Wiring Harness  
 OEM Connector: 2317368-1  
 Service Connector: Service by Harness - See Part Catalog  
 Description: 2-Way F 9.5 MCON-LL Series( BK)

**Connector Part Information**

Harness Type: Auxiliary Fuse Block Wiring Harness  
 OEM Connector: 2317373-1  
 Service Connector: Service by Harness - See Part Catalog  
 Description: 2-Way M 9.5 MCON-LL Series( BK)

**Terminal Part Information**

Terminal Type ID	Terminated Lead	Diagnostic Test Probe	Terminal Removal Tool
I	Not required	J-35616-22 (RD)	No Tool Required
II	Not required	J-35616-21 (RD)	No Tool Required

**X630 Auxiliary Fuse Block Wiring Harness to Auxiliary Fuse Block Wiring Harness**

Pin	Size	Color	Circuit	Terminal Type ID	Option	Function	Pin	Size	Color	Circuit	Terminal Type ID	Option
1	10	RD / VT	542	I	—	Battery Positive Voltage	1	10	RD / VT	542	II	—
2	—	—	—	—	—	Not Occupied	2	—	—	—	—	—

**X700 Rear Side Door Door Wiring Harness - Left Rear to Body Wiring Harness**

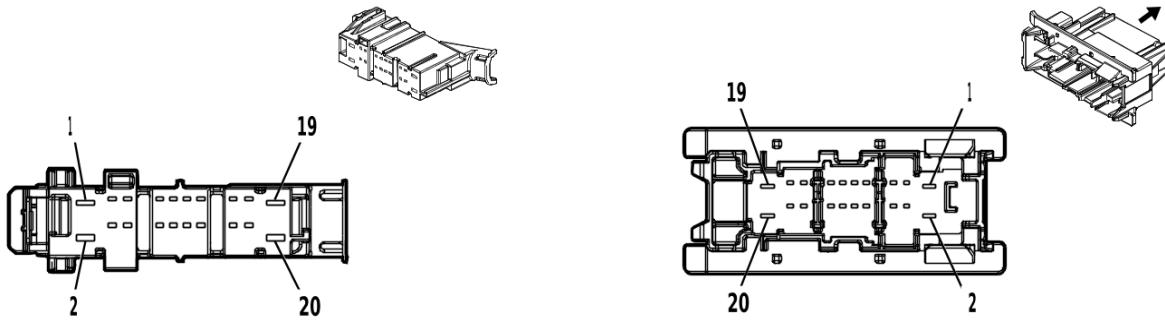

4650257

4663657

**Connector Part Information**

Harness Type: Rear Side Door Door Wiring Harness - Left Rear  
 OEM Connector: 6098-8196  
 Service Connector: Service by Harness - See Part Catalog  
 Description: 20-Way F 1.2 MCON, 2.8 MCP Series( BK)

**Connector Part Information**

Harness Type: Body Wiring Harness  
 OEM Connector: 6098-8887  
 Service Connector: 13527239  
 Description: 20-Way M 1.2 MCON, 2.8 MCP Series( BK)

**Terminal Part Information**

Terminal Type ID	Terminated Lead	Diagnostic Test Probe	Terminal Removal Tool
I	Not required	J-35616-16 (L-GN)	No Tool Required
II	Not required	J-35616-35 (VT)	No Tool Required
III	13586064	J-35616-5 (PU)	J-38125-212
IV	84616651	J-35616-13 (BU)	J-38125-215A

**X700 Rear Side Door Door Wiring Harness - Left Rear to Body Wiring Harness**

Pin	Size	Color	Circuit	Terminal Type ID	Option	Function	Pin	Size	Color	Circuit	Terminal Type ID	Option
1	2.5	RD / BU	3240	II	—	Battery Positive Voltage	1	2.5	RD / BU	3240	III	—
2-5	—	—	—	—	—	Not Occupied	2-5	—	—	—	—	—
6	0.75	WH	2679	I	—	Lock Actuators Unlock Control 1	6	0.75	WH	2679	IV	—
7	0.75	BU / YE	1091	I	—	Left Rear Door Lock Actuator Lock Control	7	0.75	BU / YE	1091	IV	—
8	—	—	—	—	—	Not Occupied	8	—	—	—	—	—
9	0.5	BK / OG	6623	I	—	Left Rear Side Impact Sensor Low Reference	9	0.5	BK / OG	6623	IV	—
10	—	—	—	—	—	Not Occupied	10	—	—	—	—	—
11	0.5	OG / BU	6622	I	—	Left Rear Side Impact Sensor Signal	11	0.5	OG / BU	6622	IV	—

## 6-896 Electrical Component and Inline Harness Connector End Views

### X700 Rear Side Door Door Wiring Harness - Left Rear to Body Wiring Harness (cont'd)

Pin	Size	Color	Circuit	Terminal Type ID	Option	Function	Pin	Size	Color	Circuit	Terminal Type ID	Option
12	0.5	GN / GY	6135	I	—	Body Control Module LIN Bus 4	12	0.35	GN / GY	6135	IV	—
13 - 16	—	—	—	—	—	Not Occupied	13 - 16	—	—	—	—	—
17	0.75	GN	199	I	—	Left Rear Speaker [+] Control	17	0.75	GN	199	IV	UQA/ UQF
18	0.75	GN / BK	116	I	—	Left Rear Speaker [-] Control	18	0.75	GN / BK	116	IV	UQA/ UQF
19	—	—	—	—	—	Not Occupied	19	—	—	—	—	—
20	2.5	BK	1550	II	—	Ground	20	2.5	BK	1550	III	—

**X800 Rear Side Door Door Wiring Harness - Right Rear to Body Wiring Harness**

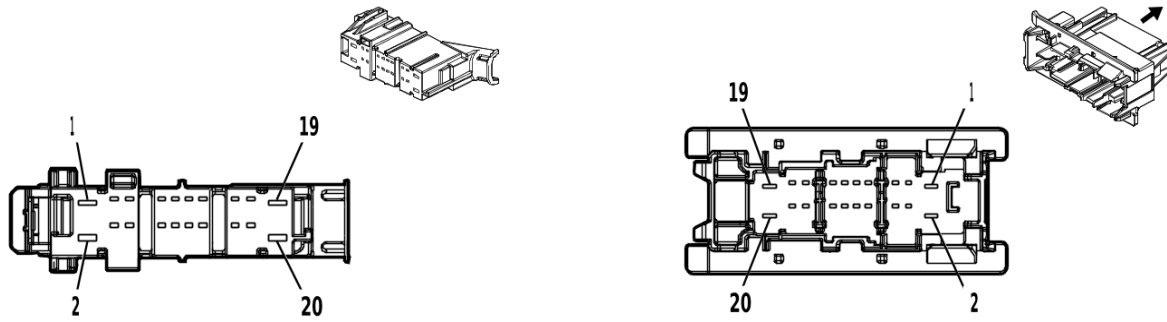

4650257

4663657

**Connector Part Information**

Harness Type: Rear Side Door Door Wiring Harness - Right Rear  
 OEM Connector: 6098-8196  
 Service Connector: Service by Harness - See Part Catalog  
 Description: 20-Way F 1.2 MCON, 2.8 MCP Series( BK)

**Connector Part Information**

Harness Type: Body Wiring Harness  
 OEM Connector: 6098-8887  
 Service Connector: 13527239  
 Description: 20-Way M 1.2 MCON, 2.8 MCP Series( BK)

**Terminal Part Information**

Terminal Type ID	Terminated Lead	Diagnostic Test Probe	Terminal Removal Tool
I	Not required	J-35616-16 (L-GN)	No Tool Required
II	Not required	J-35616-35 (VT)	No Tool Required
III	13586064	J-35616-5 (PU)	J-38125-212
IV	84616651	J-35616-13 (BU)	J-38125-215A

**X800 Rear Side Door Door Wiring Harness - Right Rear to Body Wiring Harness**

Pin	Size	Color	Circuit	Terminal Type ID	Option	Function	Pin	Size	Color	Circuit	Terminal Type ID	Option
1	2.5	YE / BK	4840	II	—	Battery Positive Voltage	1	2.5	RD / GY	4840	III	—
2-5	—	—	—	—	—	Not Occupied	2-5	—	—	—	—	—
6	0.75	GY / BK	2680	I	—	Lock Actuators Unlock Control 2	6	0.75	GY / BK	2680	IV	—
7	0.75	VT / WH	1094	I	—	Right Rear Door Lock Actuator Lock Control	7	0.75	VT / WH	1094	IV	—
8	—	—	—	—	—	Not Occupied	8	—	—	—	—	—
9	0.5	BK / OG	6627	I	—	Right Rear Side Impact Sensor Low Reference	9	0.5	BK / OG	6627	IV	—
10	—	—	—	—	—	Not Occupied	10	—	—	—	—	—
11	0.5	OG / WH	6626	I	—	Right Rear Side Impact Sensor Signal	11	0.5	OG / WH	6626	IV	—

**6-898 Electrical Component and Inline Harness Connector End Views**

**X800 Rear Side Door Door Wiring Harness - Right Rear to Body Wiring Harness (cont'd)**

Pin	Size	Color	Circuit	Terminal Type ID	Option	Function	Pin	Size	Color	Circuit	Terminal Type ID	Option
12	0.5	GN / GY	6135	I	—	Body Control Module LIN Bus 4	12	0.35	GN / GY	6135	IV	—
13 - 16	—	—	—	—	—	Not Occupied	13 - 16	—	—	—	—	—
17	0.75	WH	46	I	—	Right Rear Speaker [+] Control	17	0.75	WH	46	IV	UQA/ UQF
18	0.75	BU / BK	115	I	—	Right Rear Speaker [-] Control	18	0.75	BU / BK	115	IV	UQA/ UQF
19	—	—	—	—	—	Not Occupied	19	—	—	—	—	—
20	2.5	BK	1350	II	—	Ground	20	2.5	BK	1350	III	—



### X910 Tail Lamp Wiring Harness - Left to Chassis Wiring Harness

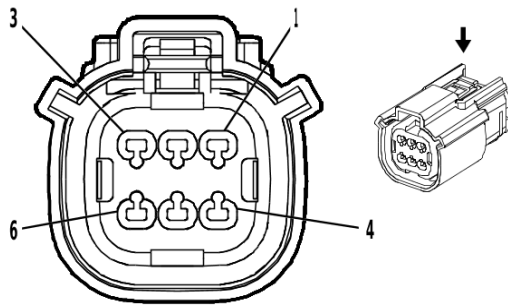

1986157

#### Connector Part Information

Harness Type: Tail Lamp Wiring Harness - Left  
 OEM Connector: 33472-0606  
 Service Connector: Service by Harness - See Part Catalog  
 Description: 6-Way F 1.5 MX Series, Sealed( BK)

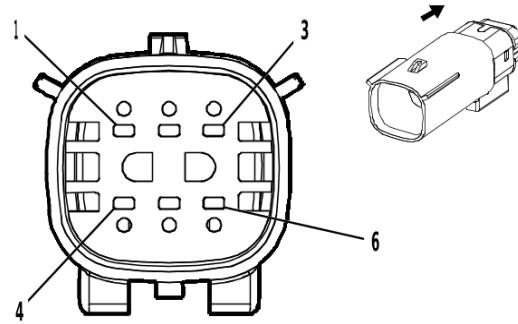

1986159

#### Connector Part Information

Harness Type: Chassis Wiring Harness  
 OEM Connector: 33482-3601  
 Service Connector: 19367742  
 Description: 6-Way M 1.5 MX Series, Sealed( BK)

#### Terminal Part Information

Terminal Type ID	Terminated Lead	Diagnostic Test Probe	Terminal Removal Tool
I	Not required	J-35616-2A (GY)	No Tool Required
II	Not required	J-35616-3 (GY)	No Tool Required

### X910 Tail Lamp Wiring Harness - Left to Chassis Wiring Harness

Pin	Size	Color	Circuit	Terminal Type ID	Option	Function	Pin	Size	Color	Circuit	Terminal Type ID	Option
1	0.75	BN	6993	I	—	Left Rear Park Lamp Control	1	0.75	BN / BU	6993	II	—
2	0.75	RD	6567	I	—	Rear Turn Signal Lamp Feedback Signal	2	0.75	WH / VT	6567	II	—
3	0.75	BU	7762	I	UF2	Cargo Lamp Control	3	0.5	GY / BU	7762	II	—
4	0.75	GN	24	I	—	Backup Lamp Control	4	0.5	GN / WH	24	II	—
5	0.75	GN	1334	I	—	Left Rear Turn Signal Lamp Control 2	5	0.75	BU / WH	1334	II	—
6	0.75	BK	1951	I	—	Signal Ground	6	0.75	BK	1951	II	—

**X918 Endgate Wiring Harness to Chassis Wiring Harness**

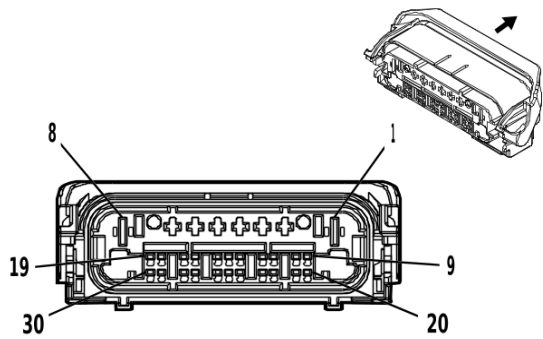

4650150

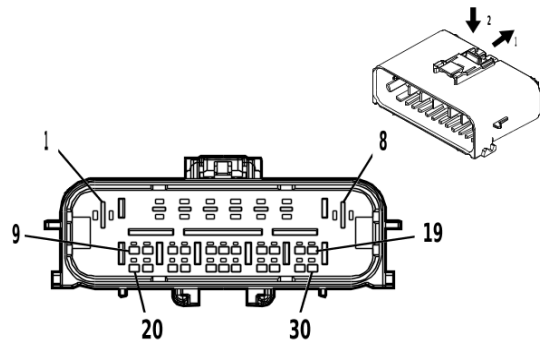

4817393

**Connector Part Information**

Harness Type: Endgate Wiring Harness  
 OEM Connector: 35573111  
 Service Connector: Service by Harness - See Part Catalog  
 Description: 30-Way F 1.2 MCON, 2.8, 6.3 MCP Series, Sealed( BK)

**Connector Part Information**

Harness Type: Chassis Wiring Harness  
 OEM Connector: 2401461-1  
 Service Connector: 19371177  
 Description: 30-Way M 1.2 MCON, 2.8, 6.3 MCP Series, Sealed( BK)

**Terminal Part Information**

Terminal Type ID	Terminated Lead	Diagnostic Test Probe	Terminal Removal Tool
I	Not required	J-35616-16 (L-GN)	No Tool Required
II	Not required	J-35616-35 (VT)	No Tool Required
III	Not required	J-35616-4A (PU)	No Tool Required
IV	13578827	J-35616-5 (PU)	J-38125-36
V	19330704	J-35616-13 (BU)	J-38125-215A

**X918 Endgate Wiring Harness to Chassis Wiring Harness**

Pin	Size	Color	Circuit	Terminal Type ID	Option	Function	Pin	Size	Color	Circuit	Terminal Type ID	Option
1	—	—	—	—	—	Not Occupied	1	—	—	—	—	—
2	2.5	RD / VT	4442	II	—	Primary Fused Battery Positive Voltage	2	2.5	RD / VT	4442	IV	—
3	2.5	BK	1850	II	—	Ground	3	2.5	BK	1850	IV	—
4	1	VT	7725	III	—	Minor Endgate Motor Control	4	1	VT	7725	IV	—
5	1	YE / BK	7730	III	—	Major Endgate Motor Low Reference	5	1	YE / BK	7730	IV	—
6	1	GN	1299	III	—	Major Endgate Motor Control	6	1	GN	1299	IV	—
7 - 8	—	—	—	—	—	Not Occupied	7 - 8	—	—	—	—	—
9	0.5	WH / VT	1430	I	—	Exterior Courtesy Lamp Control	9	0.5	WH / VT	1430	V	—

**X918 Endgate Wiring Harness to Chassis Wiring Harness (cont'd)**

Pin	Size	Color	Circuit	Terminal Type ID	Option	Function	Pin	Size	Color	Circuit	Terminal Type ID	Option
10	0.5	YE	7294	I	—	Minor Endgate Release Switch Discrete Signal Exterior	10	0.5	YE	7294	V	—
11	0.75	YE / BU	7295	I	—	Left Minor Endgate Ajar Signal	11	0.75	YE / BU	7295	V	—
12 - 17	—	—	—	—	—	Not Occupied	12 - 17	—	—	—	—	—
18	0.5	BU / VT	4101	I	—	AUTOSAR CAN Bus [+] 4 Serial Data	18	0.5	BU / VT	4101	V	—
19	0.5	WH	4100	I	—	AUTOSAR CAN Bus [-] 4 Serial Data	19	0.5	WH	4100	V	—
20	0.5	YE	1144	I	—	Endgate Release Switch Discrete Signal Exterior	20	0.5	YE	1144	V	—
21	0.5	GY	7292	I	—	Major Endgate Release Switch Signal Exterior	21	0.5	GY	7292	V	—
22 - 28	—	—	—	—	—	Not Occupied	22 - 28	—	—	—	—	—
29	0.5	WH	4100	I	—	AUTOSAR CAN Bus [-] 4 Serial Data	29	0.5	WH	4100	V	—
30	0.5	BU / VT	4101	I	—	AUTOSAR CAN Bus [+] 4 Serial Data	30	0.5	BU / VT	4101	V	—

**X919 Endgate Wiring Harness to Chassis Wiring Harness**

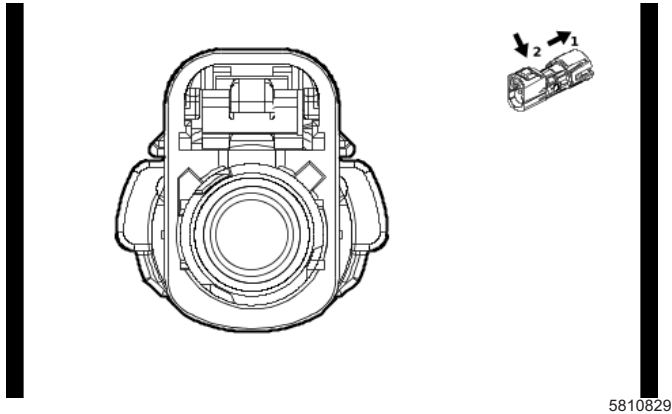

5810829

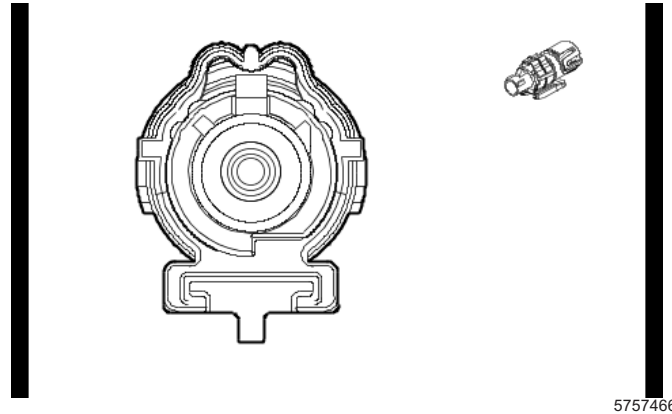

5757466

**Connector Part Information**

Harness Type: Endgate Wiring Harness COAX  
 OEM Connector: 35187033  
 Service Connector: Service by Cable Assembly — See Part Catalog  
 Description: 1-Way F Coax Type( WH)

**Connector Part Information**

Harness Type: Chassis Wiring Harness COAX  
 OEM Connector: 33338240  
 Service Connector: Service by Cable Assembly — See Part Catalog  
 Description: 1-Way M Coax Type, Sealed( WH)

**Terminal Part Information**

Terminal Type ID	Terminated Lead	Diagnostic Test Probe	Terminal Removal Tool
I	Not required	No Tool Required	No Tool Required

**X919 Endgate Wiring Harness to Chassis Wiring Harness**

Pin	Size	Color	Circuit	Terminal Type ID	Option	Function	Pin	Size	Color	Circuit	Terminal Type ID	Option
—	—	Coax Cable	—	I	—	Rear Vision Camera Co-axial Video Signal	—	—	Coax Cable	—	I	—

**X920 Tail Lamp Wiring Harness - Right to Chassis Wiring Harness**

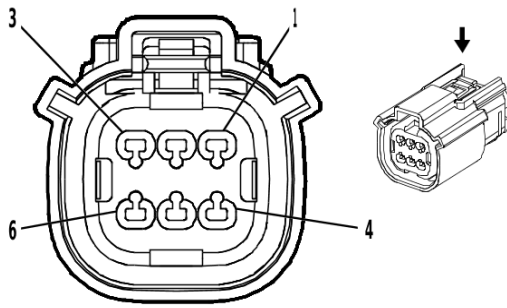

1986157

**Connector Part Information**

Harness Type: Tail Lamp Wiring Harness - Right  
 OEM Connector: 33472-0606  
 Service Connector: Service by Harness - See Part Catalog  
 Description: 6-Way F 1.5 MX Series, Sealed( BK)

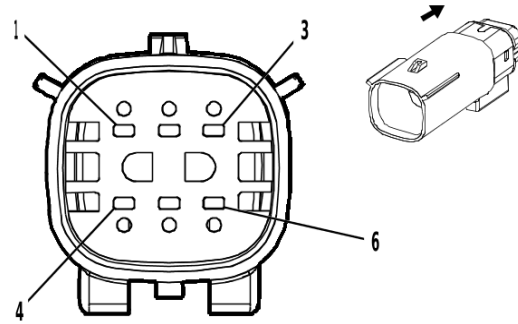

1986159

**Connector Part Information**

Harness Type: Chassis Wiring Harness  
 OEM Connector: 33482-3601  
 Service Connector: 19367742  
 Description: 6-Way M 1.5 MX Series, Sealed( BK)

**Terminal Part Information**

Terminal Type ID	Terminated Lead	Diagnostic Test Probe	Terminal Removal Tool
I	Not required	J-35616-2A (GY)	No Tool Required
II	Not required	J-35616-3 (GY)	No Tool Required

**X920 Tail Lamp Wiring Harness - Right to Chassis Wiring Harness**

Pin	Size	Color	Circuit	Terminal Type ID	Option	Function	Pin	Size	Color	Circuit	Terminal Type ID	Option
1	0.75	BN	6995	I	—	Right Rear Park Lamp Control	1	0.75	BN / GY	6995	II	—
2	0.75	RD	7544	I	—	Right Rear Turn Signal Lamp Feedback Signal	2	0.75	WH / BK	7544	II	—
3	0.75	BU	7762	I	UF2	Cargo Lamp Control	3	0.5	GY / BU	7762	II	—
4	0.75	GN	24	I	—	Backup Lamp Control	4	0.5	GN / WH	24	II	—
5	0.75	GN	1335	I	—	Right Rear Turn Signal Lamp Control 2	5	0.75	BU / VT	1335	II	—
6	0.75	BK	1850	I	—	Ground	6	0.75	BK	1850	II	—

**X944 Engine Wiring Harness to Engine Coolant Temperature Sensor Harness (LZ0)**

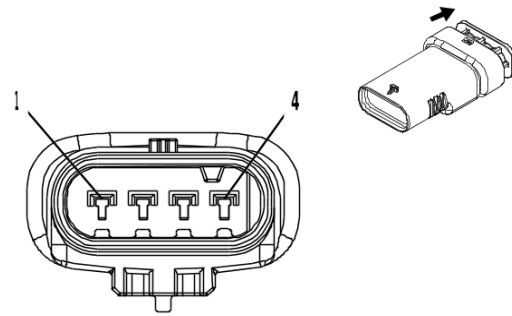
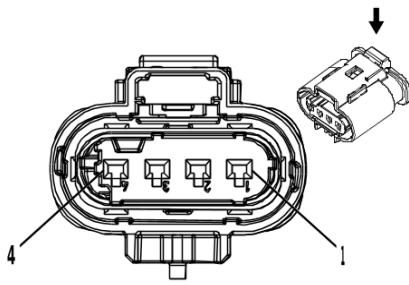

2717079

4560843

**Connector Part Information**

Harness Type: Engine Wiring Harness  
 OEM Connector: 10010346  
 Service Connector: 13587299  
 Description: 4-Way F 1.2 Multilock Series, Sealed( BK)

**Connector Part Information**

Harness Type: Engine Coolant Temperature Sensor Harness  
 OEM Connector: 13503594  
 Service Connector: Service by Harness - See Part Catalog  
 Description: 4-Way M 1.2 Multilock Series, Sealed( GY)

**Terminal Part Information**

Terminal Type ID	Terminated Lead	Diagnostic Test Probe	Terminal Removal Tool
I	Not required	J-35616-16 (L-GN)	No Tool Required
II	Not required	J-35616-13 (BU)	No Tool Required

**X944 Engine Wiring Harness to Engine Coolant Temperature Sensor Harness (LZ0)**

Pin	Size	Color	Circuit	Terminal Type ID	Option	Function	Pin	Size	Color	Circuit	Terminal Type ID	Option
1-2	—	—	—	—	—	Not Occupied	1-2	—	—	—	—	—
3	0.5	VT	2988	I	—	Engine Outlet Coolant Temperature Signal	3	0.5	VT	2988	II	—
4	0.5	BK / GY	626	I	—	Engine Control Vehicle Sensors Low Reference 1	4	0.5	BK / GY	626	II	—

**X950 Rear Object Alarm Sensor Wiring Harness to Chassis Wiring Harness**

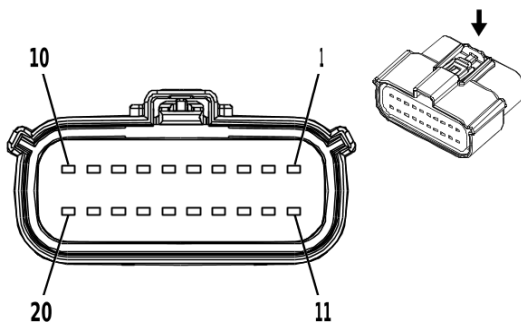

2871898

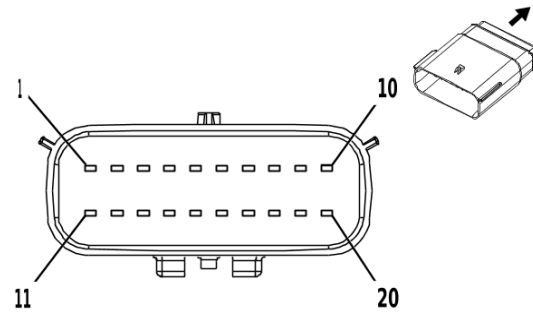

2871861

**Connector Part Information**

Harness Type: Rear Object Alarm Sensor Wiring Harness  
 OEM Connector: 13504367  
 Service Connector: Service by Harness - See Part Catalog  
 Description: 20-Way F 1.5 MX Series, Sealed( BK)

**Connector Part Information**

Harness Type: Chassis Wiring Harness  
 OEM Connector: 35554993  
 Service Connector: 19351705  
 Description: 20-Way M 1.5 MX Series, Sealed( BK)

**Terminal Part Information**

Terminal Type ID	Terminated Lead	Diagnostic Test Probe	Terminal Removal Tool
I	Not required	J-35616-2A (GY)	No Tool Required
II	86800300	J-35616-3 (GY)	J-38125-217

**X950 Rear Object Alarm Sensor Wiring Harness to Chassis Wiring Harness**

Pin	Size	Color	Circuit	Terminal Type ID	Option	Function	Pin	Size	Color	Circuit	Terminal Type ID	Option
1	0.5	RD / GN	6940	I	—	Battery Positive Voltage	1	0.5	RD / GN	6940	II	—
2	—	—	—	—	—	Battery Positive Voltage	2	0.5	RD / BU	5240	II	—
3	0.5	WH	4100	I	—	AUTOSAR CAN Bus [-] 4 Serial Data	3	0.5	WH	4100	II	—
4	0.5	BU / VT	4101	I	—	AUTOSAR CAN Bus [+] 4 Serial Data	4	0.5	BU / VT	4101	II	—
5	—	—	—	—	—	AUTOSAR CAN Bus [-] 8 Serial Data	5	0.5	WH / GY	4104	II	—
6	—	—	—	—	—	AUTOSAR CAN Bus [+] 8 Serial Data	6	0.5	BU / GY	4105	II	—
7	—	—	—	—	—	AUTOSAR CAN Bus [-] 8 Serial Data	7	0.5	WH / GY	4104	II	—
8	—	—	—	—	—	AUTOSAR CAN Bus [+] 8 Serial Data	8	0.5	BU / GY	4105	II	—
9	0.5	BN / WH	2374	I	—	Object Sensor Voltage Reference	9	0.5	BN / WH	2374	II	—

**6-906 Electrical Component and Inline Harness Connector End Views**

**X950 Rear Object Alarm Sensor Wiring Harness to Chassis Wiring Harness (cont'd)**

Pin	Size	Color	Circuit	Terminal Type ID	Option	Function	Pin	Size	Color	Circuit	Terminal Type ID	Option
10	0.5	YE	2375	I	—	Left Rear Outer Parking Assist Sensor Signal	10	0.5	YE	2375	II	—
11	0.5	YE / BU	2376	I	—	Left Rear Middle Parking Assist Sensor Signal	11	0.5	YE / BU	2376	II	—
12	0.5	YE / WH	2377	I	—	Right Rear Middle Parking Assist Sensor Signal	12	0.5	YE / WH	2377	II	—
13	0.5	YE / VT	2378	I	—	Right Rear Outer Parking Assist Sensor Signal	13	0.5	YE / VT	2378	II	—
14	0.5	BK / GY	2379	I	—	Object Sensor Low Reference	14	0.5	BK / GY	2379	II	—
15	0.5	GN / YE	6846	I	—	Rear License Plate Lamp Control	15	0.5	GN / YE	6846	II	—
16	0.75	BK	1850	I	—	Ground	16	0.75	BK	1850	II	—
17	0.5	BK / WH	1951	I	—	Signal Ground	17	0.5	BK / WH	1951	II	—
18 - 20	—	—	—	—	—	Not Occupied	18 - 20	—	—	—	—	—



## X961 Engine Wiring Harness to Valve Rocker Arm Oil Control Valve Extension Harness

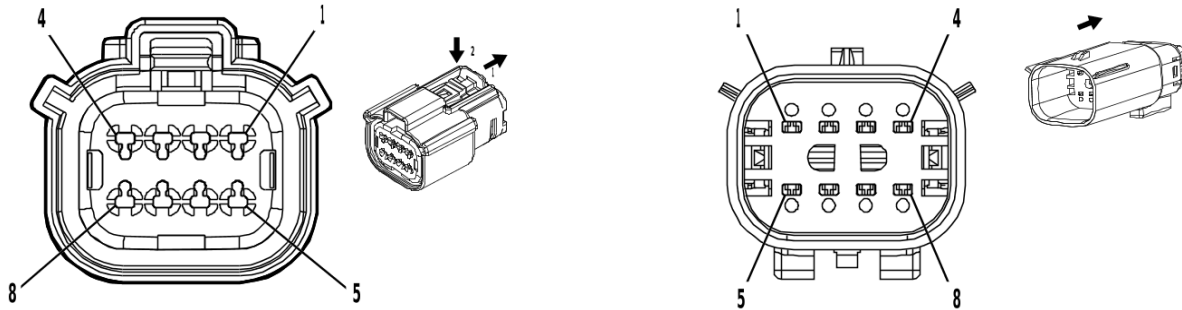

4846407

2667653

### Connector Part Information

Harness Type: Engine Wiring Harness  
 OEM Connector: 33472-4806  
 Service Connector: 84928314  
 Description: 8-Way F 1.5 MX Series, Sealed( BK)

### Connector Part Information

Harness Type: Valve Rocker Arm Oil Control Valve Extension Harness  
 OEM Connector: Not Available  
 Service Connector: Service by Harness - See Part Catalog  
 Description: 8-Way M ( BK)

### Terminal Part Information

Terminal Type ID	Terminated Lead	Diagnostic Test Probe	Terminal Removal Tool
I	Not required	J-35616-14 (GN)	No Tool Required
II	Not required	No Tool Required	No Tool Required

## X961 Engine Wiring Harness to Valve Rocker Arm Oil Control Valve Extension Harness

Pin	Size	Color	Circuit	Terminal Type ID	Option	Function	Pin	Size	Color	Circuit	Terminal Type ID	Option
1	0.5	WH / GN	2492	I	—	Cylinder Shutoff Solenoid Enable Signal 2	1	0.5	WH / GN	2492	II	—
2	0.5	GN	5492	I	—	Cylinder Deactivation Solenoid Valve Control 2	2	0.5	GN	5492	II	—
3	0.5	YE / GY	2493	I	—	Cylinder Shutoff Solenoid Enable Signal 3	3	0.5	YE / GY	2493	II	—
4	0.5	GY	5493	I	—	Cylinder Deactivation Solenoid Valve Control 3	4	0.5	GY	5493	II	—
5	0.5	WH / VT	2495	I	—	Cylinder Shutoff Solenoid Enable Signal 5	5	0.5	WH / VT	2495	II	—
6	0.5	VT	5495	I	—	Cylinder Deactivation Solenoid Valve Control 5	6	0.5	VT	5495	II	—

**6-908 Electrical Component and Inline Harness Connector End Views**

**X961 Engine Wiring Harness to Valve Rocker Arm Oil Control Valve Extension Harness  
(cont'd)**

Pin	Size	Color	Circuit	Terminal Type ID	Option	Function	Pin	Size	Color	Circuit	Terminal Type ID	Option
7	0.5	WH / YE	2498	I	—	Cylinder Shutoff Solenoid Enable Signal 8	7	0.5	WH / YE	2498	II	—
8	0.5	YE	5498	I	—	Cylinder Deactivation Solenoid Valve Control 8	8	0.5	YE	5498	II	—

## X962 Engine Wiring Harness to Valve Rocker Arm Oil Control Valve Extension Harness

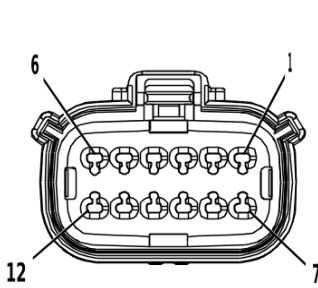

2871860

### Connector Part Information

Harness Type: Engine Wiring Harness  
 OEM Connector: 33472-1266  
 Service Connector: 19352907  
 Description: 12-Way F 1.5 MX Series, Sealed( BK)

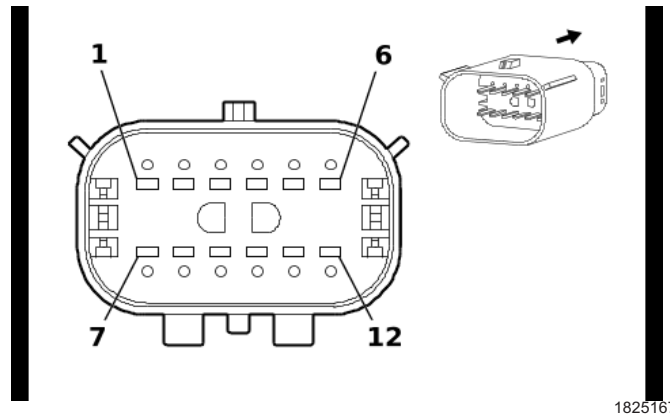

1825167

### Connector Part Information

Harness Type: Valve Rocker Arm Oil Control Valve Extension Harness  
 OEM Connector: Not Available  
 Service Connector: Service by Harness - See Part Catalog  
 Description: 12-Way M ( BK)

### Terminal Part Information

Terminal Type ID	Terminated Lead	Diagnostic Test Probe	Terminal Removal Tool
I	19368973	J-35616-2A (GY)	J-38125-217
II	Not required	No Tool Required	No Tool Required

## X962 Engine Wiring Harness to Valve Rocker Arm Oil Control Valve Extension Harness

Pin	Size	Color	Circuit	Terminal Type ID	Option	Function	Pin	Size	Color	Circuit	Terminal Type ID	Option
1	0.5	WH / BU	2491	I	—	Cylinder Shutoff Solenoid Enable Signal 1	1	0.5	WH / BU	2491	II	—
2	0.5	BU / VT	5491	I	—	Cylinder Deactivation Solenoid Valve Control 1	2	0.5	BU / VT	5491	II	—
3	0.5	YE / GN	2494	I	—	Cylinder Shutoff Solenoid Enable Signal 4	3	0.5	YE / GN	2494	II	—
4	0.5	YE / BU	5494	I	—	Cylinder Deactivation Solenoid Valve Control 4	4	0.5	YE / BU	5494	II	—
5	0.5	YE / BN	2496	I	—	Cylinder Shutoff Solenoid Enable Signal 6	5	0.5	YE / BN	2496	II	—
6	0.5	BN	5496	I	—	Cylinder Deactivation Solenoid Valve Control 6	6	0.5	BN	5496	II	—

**6-910 Electrical Component and Inline Harness Connector End Views**

**X962 Engine Wiring Harness to Valve Rocker Arm Oil Control Valve Extension Harness (cont'd)**

Pin	Size	Color	Circuit	Terminal Type ID	Option	Function	Pin	Size	Color	Circuit	Terminal Type ID	Option
7	0.5	GN / GY	2497	I	—	Cylinder Shutoff Solenoid Enable Signal 7	7	0.5	GN / GY	2497	II	—
8	0.5	WH	5497	I	—	Cylinder Deactivation Solenoid Valve Control 7	8	0.5	WH	5497	II	—
9	0.5	BU	410	I	—	Engine Coolant Temperature Sensor Signal	9	0.5	BU	410	II	—
10	0.5	BK / GY	626	I	—	Engine Control Vehicle Sensors Low Reference 1	10	0.5	BK / GY	626	II	—
11 - 12	—	—	—	—	—	Not Occupied	11 - 12	—	—	—	—	—

**X963 Valve Rocker Arm Oil Control Valve Extension Harness to Valve Rocker Arm Oil Control Valve Harness (L84 / L87)**

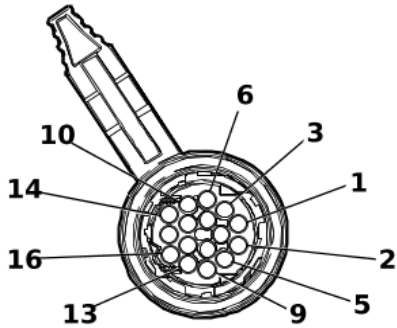

5573634

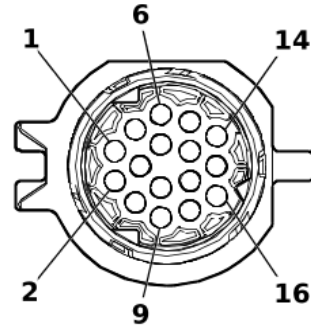

5575849

**Connector Part Information**

Harness Type: Valve Rocker Arm Oil Control Valve Extension Harness  
 OEM Connector: 10354998  
 Service Connector: Service by Harness - See Part Catalog  
 Description: 16-Way F 1.5 LKS Series, Sealed( BK)

**Connector Part Information**

Harness Type: Valve Rocker Arm Oil Control Valve Harness  
 OEM Connector: 10140573  
 Service Connector: Service by Harness - See Part Catalog  
 Description: 16-Way M 1.5 LKS Series, Sealed( BK)

**Terminal Part Information**

Terminal Type ID	Terminated Lead	Diagnostic Test Probe	Terminal Removal Tool
I	Not required	J-35616-2A (GY)	No Tool Required
II	Not required	J-35616-3 (GY)	No Tool Required

**X963 Valve Rocker Arm Oil Control Valve Extension Harness to Valve Rocker Arm Oil Control Valve Harness (L84 / L87)**

Pin	Size	Color	Circuit	Terminal Type ID	Option	Function	Pin	Size	Color	Circuit	Terminal Type ID	Option
1	0.5	WH / GN	2492	I	—	Cylinder Shutoff Solenoid Enable Signal 2	1	0.5	WH / GN	2492	II	—
2	0.5	GN	5492	I	—	Cylinder Deactivation Solenoid Valve Control 2	2	0.5	GN	5492	II	—
3	0.5	YE / GY	2493	I	—	Cylinder Shutoff Solenoid Enable Signal 3	3	0.5	YE / GY	2493	II	—
4	0.5	GY	5493	I	—	Cylinder Deactivation Solenoid Valve Control 3	4	0.5	GY	5493	II	—
5	0.5	WH / VT	2495	I	—	Cylinder Shutoff Solenoid Enable Signal 5	5	0.5	WH / VT	2495	II	—

**6-912 Electrical Component and Inline Harness Connector End Views**

**X963 Valve Rocker Arm Oil Control Valve Extension Harness to Valve Rocker Arm Oil Control Valve Harness (L84 / L87) (cont'd)**

Pin	Size	Color	Circuit	Terminal Type ID	Option	Function	Pin	Size	Color	Circuit	Terminal Type ID	Option
6	0.5	VT	5495	I	—	Cylinder De-activation Solenoid Valve Control 5	6	0.5	VT	5495	II	—
7	0.5	WH / YE	2498	I	—	Cylinder Shutoff Solenoid Enable Signal 8	7	0.5	WH / YE	2498	II	—
8	0.5	YE	5498	I	—	Cylinder De-activation Solenoid Valve Control 8	8	0.5	YE	5498	II	—
9	0.5	WH / BU	2491	I	—	Cylinder Shutoff Solenoid Enable Signal 1	9	0.5	WH / BU	2491	II	—
10	0.5	BU	5491	I	—	Cylinder De-activation Solenoid Valve Control 1	10	0.5	BU	5491	II	—
11	0.5	YE / GN	2494	I	—	Cylinder Shutoff Solenoid Enable Signal 4	11	0.5	YE / GN	2494	II	—
12	0.5	YE / BU	5494	I	—	Cylinder De-activation Solenoid Valve Control 4	12	0.5	YE / BU	5494	II	—
13	0.5	YE / BN	2496	I	—	Cylinder Shutoff Solenoid Enable Signal 6	13	0.5	YE / BN	2496	II	—
14	0.5	BN	5496	I	—	Cylinder De-activation Solenoid Valve Control 6	14	0.5	BN	5496	II	—
15	0.5	GN / GY	2497	I	—	Cylinder Shutoff Solenoid Enable Signal 7	15	0.5	GN / GY	2497	II	—
16	0.5	WH	5497	I	—	Cylinder De-activation Solenoid Valve Control 7	16	0.5	WH	5497	II	—

**X985 Rearview Driver Information Camera Rear Closure Coaxial Cable to Inside Rearview Mirror Wiring Harness - Jumper (DRZ)**

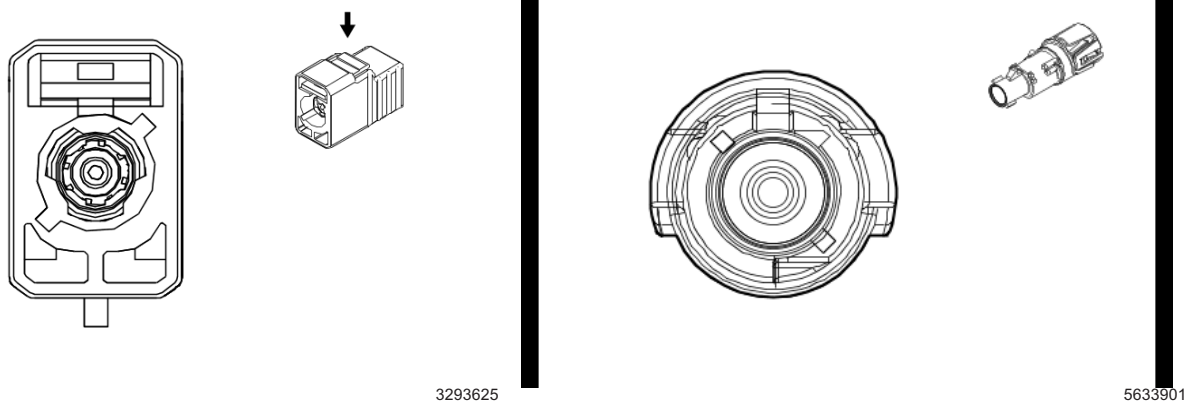

**Connector Part Information**

Harness Type: Rearview Driver Information Camera Rear Closure Coaxial Cable COAX  
 OEM Connector: Not Available  
 Service Connector: Service by Cable Assembly — See Part Catalog  
 Description: 1-Way F

**Connector Part Information**

Harness Type: Inside Rearview Mirror Wiring Harness - Jumper COAX  
 OEM Connector: 33355540  
 Service Connector: Service by Cable Assembly — See Part Catalog  
 Description: 1-Way M Coax Type, Sealed( BU)

**Terminal Part Information**

Terminal Type ID	Terminated Lead	Diagnostic Test Probe	Terminal Removal Tool
I	Not required	No Tool Required	No Tool Required

**X985 Rearview Driver Information Camera Rear Closure Coaxial Cable to Inside Rearview Mirror Wiring Harness - Jumper (DRZ)**

Pin	Size	Color	Circuit	Terminal Type ID	Option	Function	Pin	Size	Color	Circuit	Terminal Type ID	Option
—	—	Coax Cable	—	I	—	Rear Vision Camera Coaxial Video Signal	—	—	Coax Cable	—	I	—

# Electrical Component Locator and Harness Routing Views

## Schematic and Routing Diagrams

### Harness Routing Views (Front of Vehicle - Front Object Alarm Sensor Wiring Harness (-GRZ - VHU))

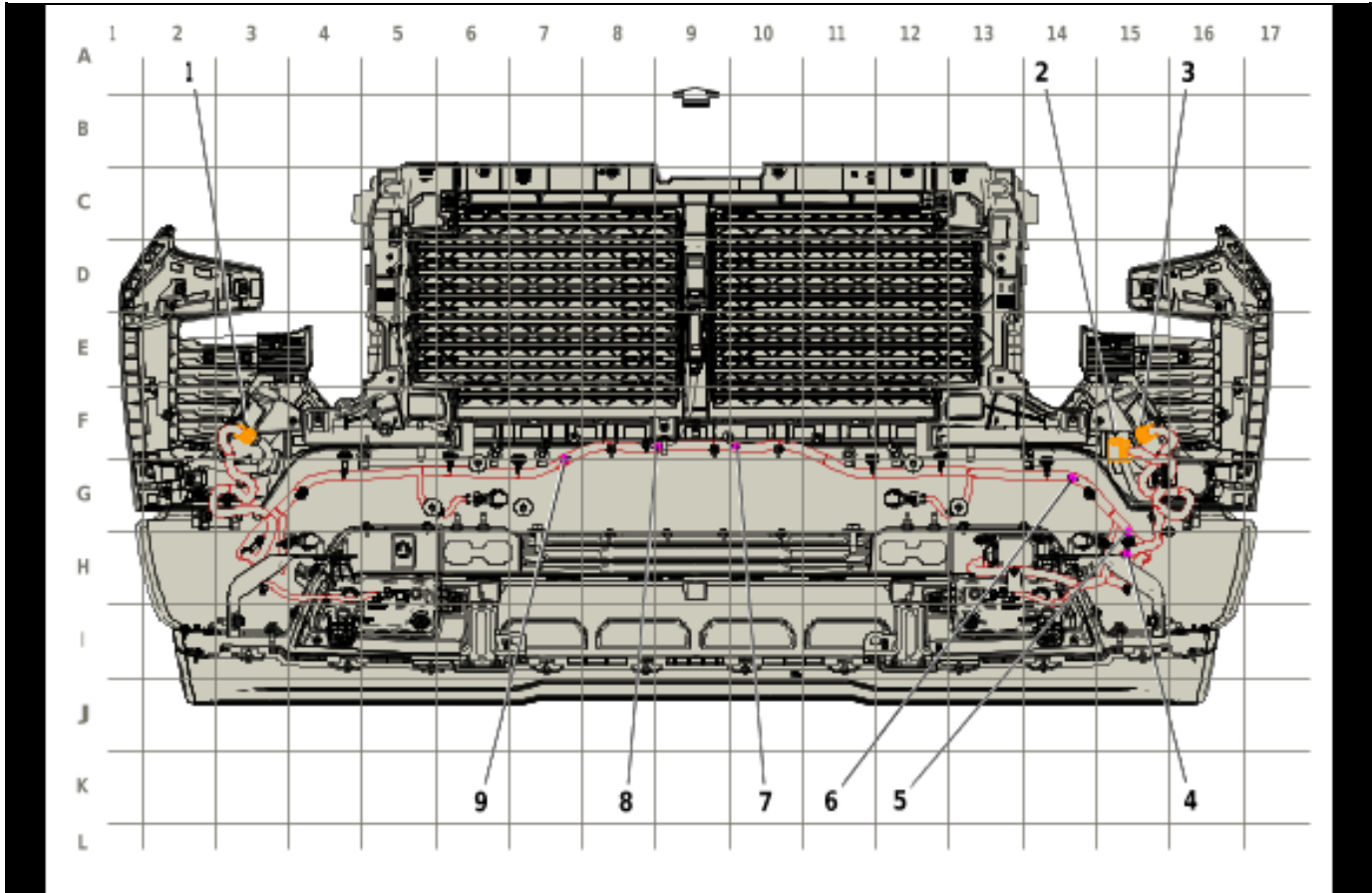

6141577

**Items**

- |   |  |
|---|--|
| <ul style="list-style-type: none"> <li>(1) X162 Front Object Alarm Sensor Wiring Harness to Front Object Alarm Sensor Wiring Harness - Left Jumper (UKL)</li> <li>(2) X150 Front Object Alarm Sensor Wiring Harness to Body Wiring Harness (UKL)</li> <li>(3) X165 Front Object Alarm Sensor Wiring Harness to Front Object Alarm Sensor Wiring Harness - Right Jumper (UKL)</li> <li>(4) J105 Front Object Alarm Sensor Wiring Harness (UKL)</li> <li>(5) J104 Front Object Alarm Sensor Wiring Harness (UKL)</li> </ul> | <ul style="list-style-type: none"> <li>(6) J103 Front Object Alarm Sensor Wiring Harness</li> <li>(7) J102 Front Object Alarm Sensor Wiring Harness</li> <li>(8) J101 Front Object Alarm Sensor Wiring Harness</li> <li>(9) J100 Front Object Alarm Sensor Wiring Harness</li> </ul> |
|---|--|



Harness Routing Views (Front of Vehicle - Front Object Alarm Sensor Wiring Harness (VHU))

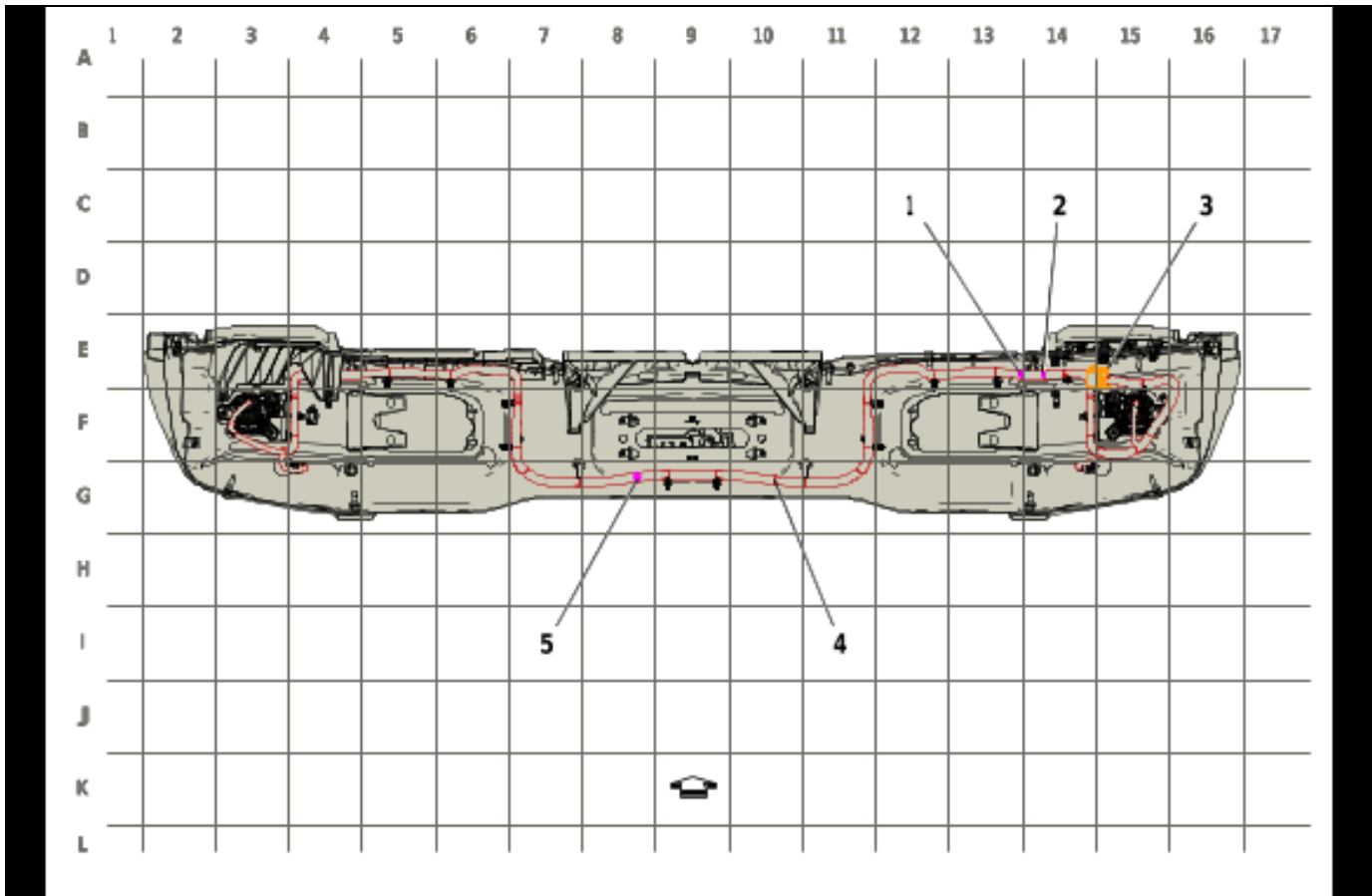

6142586

**Items**

- |  |  |
|--|--|
| <ul style="list-style-type: none"> <li>(1) J103 Front Object Alarm Sensor Wiring Harness</li> <li>(2) J100 Front Object Alarm Sensor Wiring Harness</li> <li>(3) X150 Front Object Alarm Sensor Wiring Harness to Body Wiring Harness (UKL)</li> </ul> | <ul style="list-style-type: none"> <li>(4) J101 Front Object Alarm Sensor Wiring Harness</li> <li>(5) J102 Front Object Alarm Sensor Wiring Harness</li> </ul> |
|--|--|

Harness Routing Views (Vehicle Underbody - Electronic Suspension Strut Wiring Harness Extension Harness)

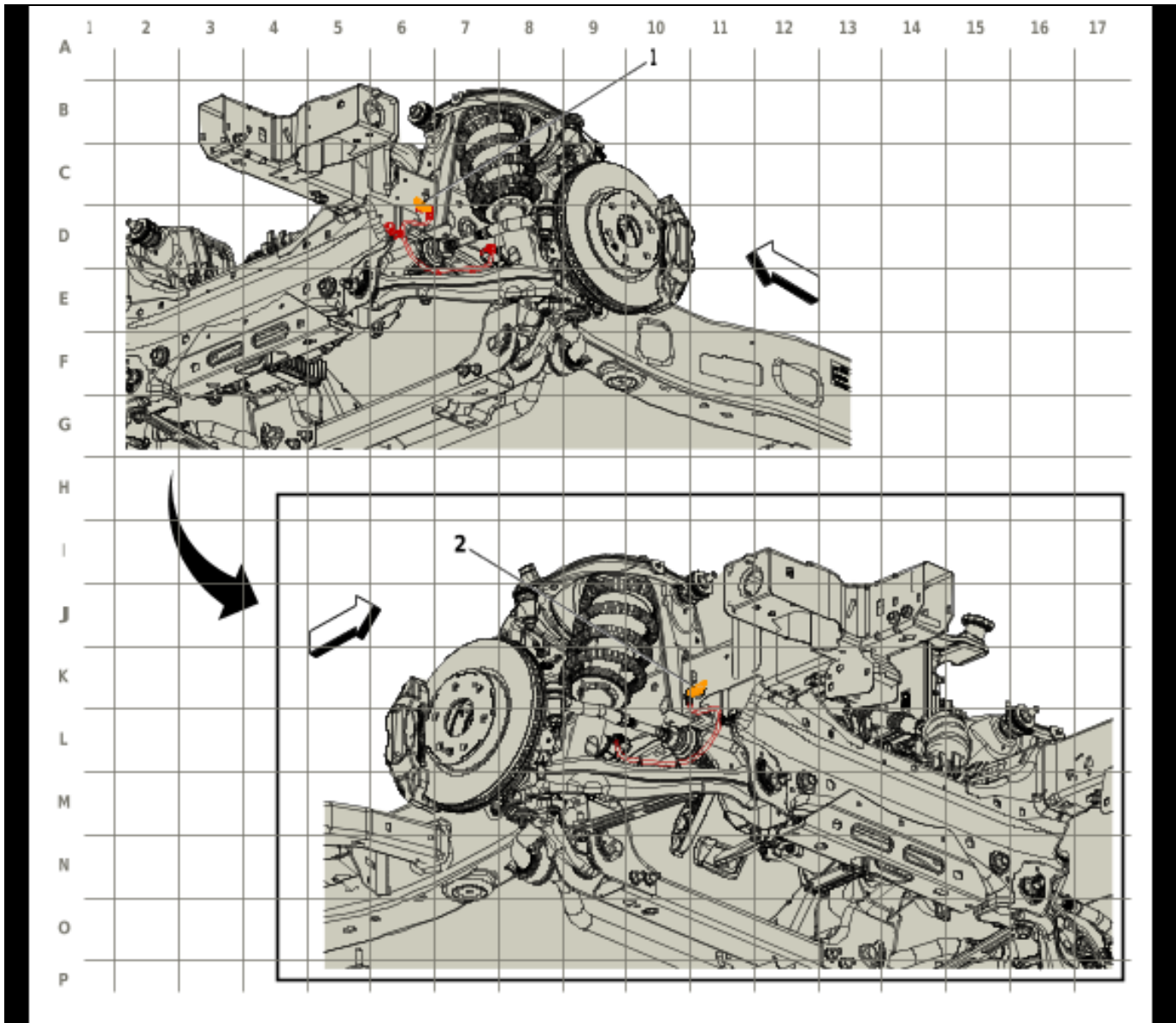

5970770

**Items**

- (1) X416A Chassis Wiring Harness to Electronic Suspension Strut Wiring Harness Extension Harness (Z45)
- (2) X416B Chassis Wiring Harness to Electronic Suspension Strut Wiring Harness Extension Harness (Z45)

Harness Routing Views (Engine Compartment - Accessory Wiring Harness (VYU))

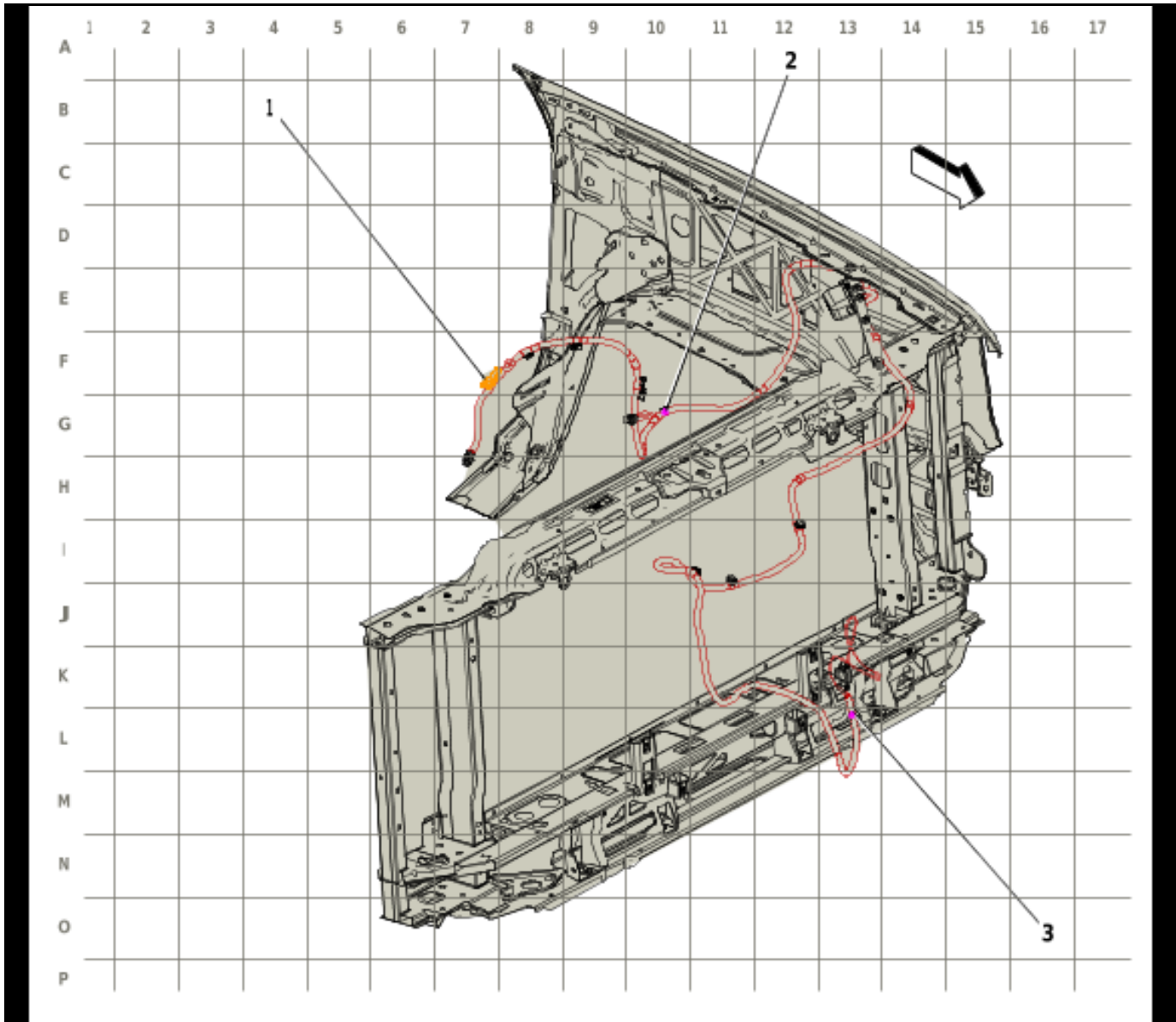

5965543

**Items**

- (1) X977 Engine Wiring Harness to Accessory Wiring Harness (VYU)
- (2) J141 Accessory Wiring Harness (VYU)

- (3) J140 Accessory Wiring Harness (VYU)

Harness Routing Views (Engine Compartment - Body Wiring Harness - Right)

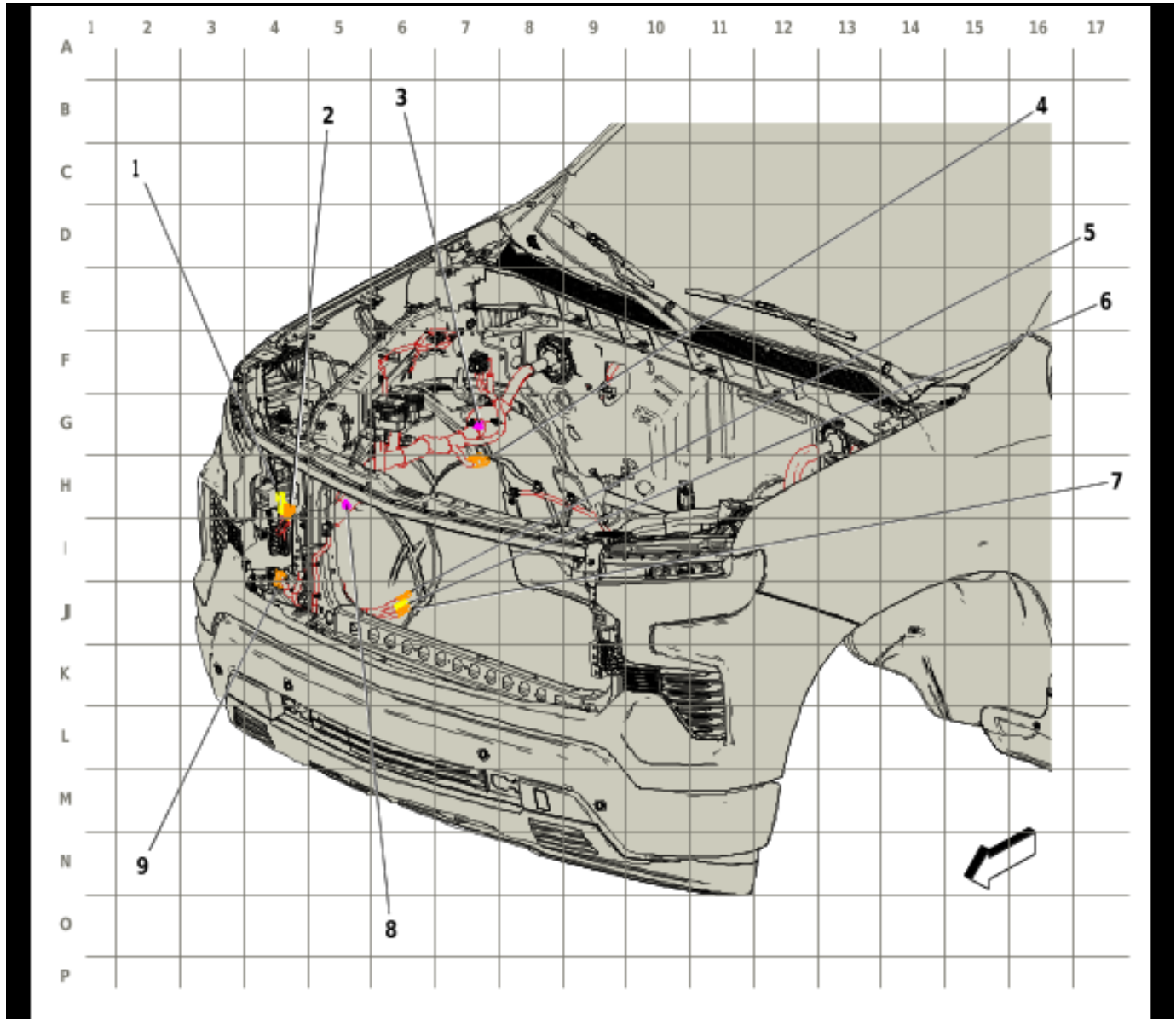

5965516

**Items**

- |   |  |
|---|--|
| <ul style="list-style-type: none"> <li>(1) X124 Front View Camera Switch Wiring Harness to Body Wiring Harness (GRZ)</li> <li>(2) X122 Front View Camera Switch Wiring Harness to Body Wiring Harness (UV2)</li> <li>(3) J132 Body Wiring Harness</li> <li>(4) X424 Body Wiring Harness to Chassis Wiring Harness (FHS)</li> <li>(5) X402B Body Wiring Harness to Chassis Wiring Harness (UV2)</li> </ul> | <ul style="list-style-type: none"> <li>(6) X402C Body Wiring Harness to Chassis Wiring Harness (UV2)</li> <li>(7) X402A Body Wiring Harness to Chassis Wiring Harness (UV2)</li> <li>(8) J131 Body Wiring Harness</li> <li>(9) X150 Front Object Alarm Sensor Wiring Harness to Body Wiring Harness (UKL)</li> </ul> |
|---|--|

Harness Routing Views (Engine Compartment - Body Wiring Harness - Left)

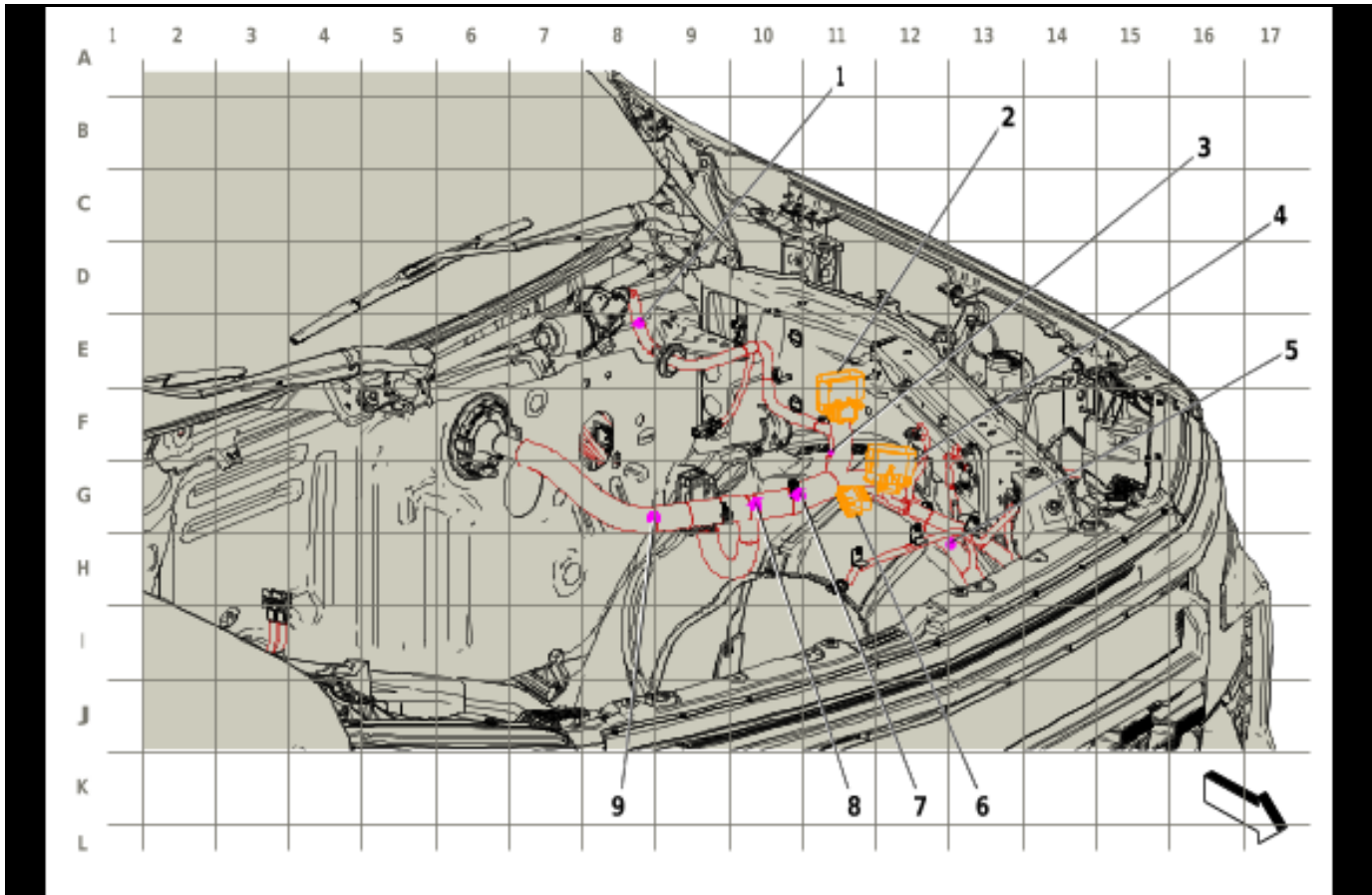

5965517

**Items**

- |  |  |
|--|--|
| (1) J127 Body Wiring Harness                           | (6) X400 Body Wiring Harness to Chassis Wiring Harness |
| (2) X410 Chassis Wiring Harness to Body Wiring Harness | (7) J128 Body Wiring Harness                           |
| (3) J126 Body Wiring Harness                           | (8) J129 Body Wiring Harness                           |
| (4) X125 Engine Wiring Harness to Body Wiring Harness  | (9) J130 Body Wiring Harness                           |
| (5) J125 Body Wiring Harness                           |  |



Harness Routing Views (Engine Compartment - Engine Wiring Harness - Left Rear (L3B))

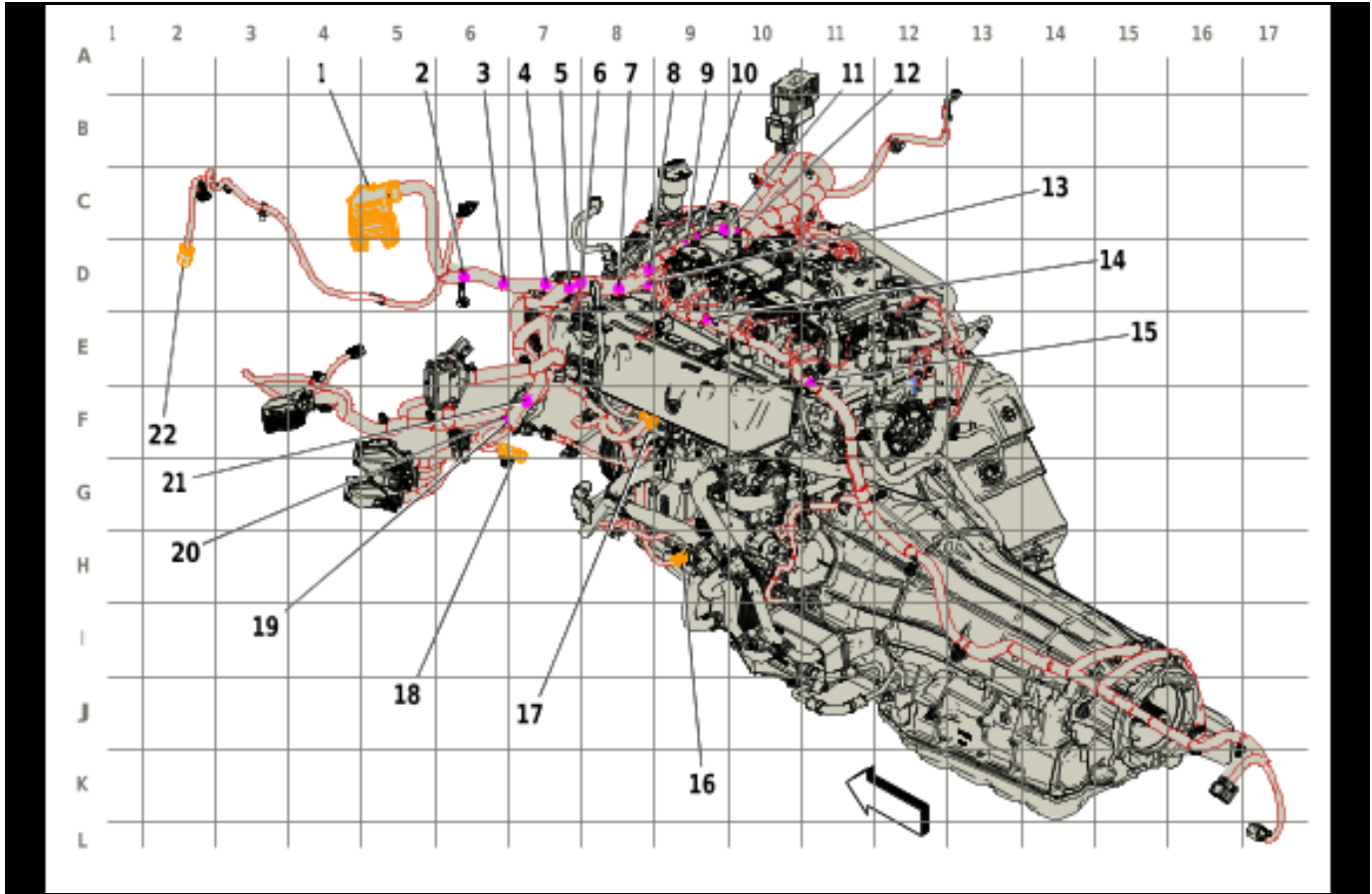

5970771

**Items**

- |      |   |      |   |
|------|---|------|---|
| (1)  | X125 Engine Wiring Harness to Body Wiring Harness | (14) | J158 Engine Wiring Harness (L3B/L84/L87)  |
| (2)  | J150 Engine Wiring Harness                        | (15) | J171 Engine Wiring Harness (L3B)  |
| (3)  | J157 Engine Wiring Harness                        | (16) | X129 Camshaft Position Sensor Wire to Oil Pump Flow Control Solenoid Valve Wire (L3B/L87/LZ0) |
| (4)  | J151 Engine Wiring Harness                        | (17) | X160 Engine Wiring Harness to Fuel Injector Wiring Harness                                    |
| (5)  | J168 Engine Wiring Harness (L3B)                  | (18) | X415B Chassis Wiring Harness to Front Wheel Speed Sensor Wiring Harness (JBP)                 |
| (6)  | J169 Engine Wiring Harness (L3B)                  | (19) | J153 Engine Wiring Harness  |
| (7)  | J170 Engine Wiring Harness (L3B)                  | (20) | J167 Engine Wiring Harness (L3B)  |
| (8)  | J164 Engine Wiring Harness                        | (21) | J155 Engine Wiring Harness (L3B/L84/L87)  |
| (9)  | J172 Engine Wiring Harness (L3B)                  | (22) | X618A Engine Wiring Harness to Active Grille Air Shutter Wiring Harness (VTI/WMI)             |
| (10) | J173 Engine Wiring Harness (L3B)                  |      |   |
| (11) | J174 Engine Wiring Harness (L3B)                  |      |   |
| (12) | J175 Engine Wiring Harness (L3B)                  |      |   |
| (13) | J156 Engine Wiring Harness (L3B/L84/L87)          |      |   |

Harness Routing Views (Engine Compartment - Engine Wiring Harness - Right Front (L3B))

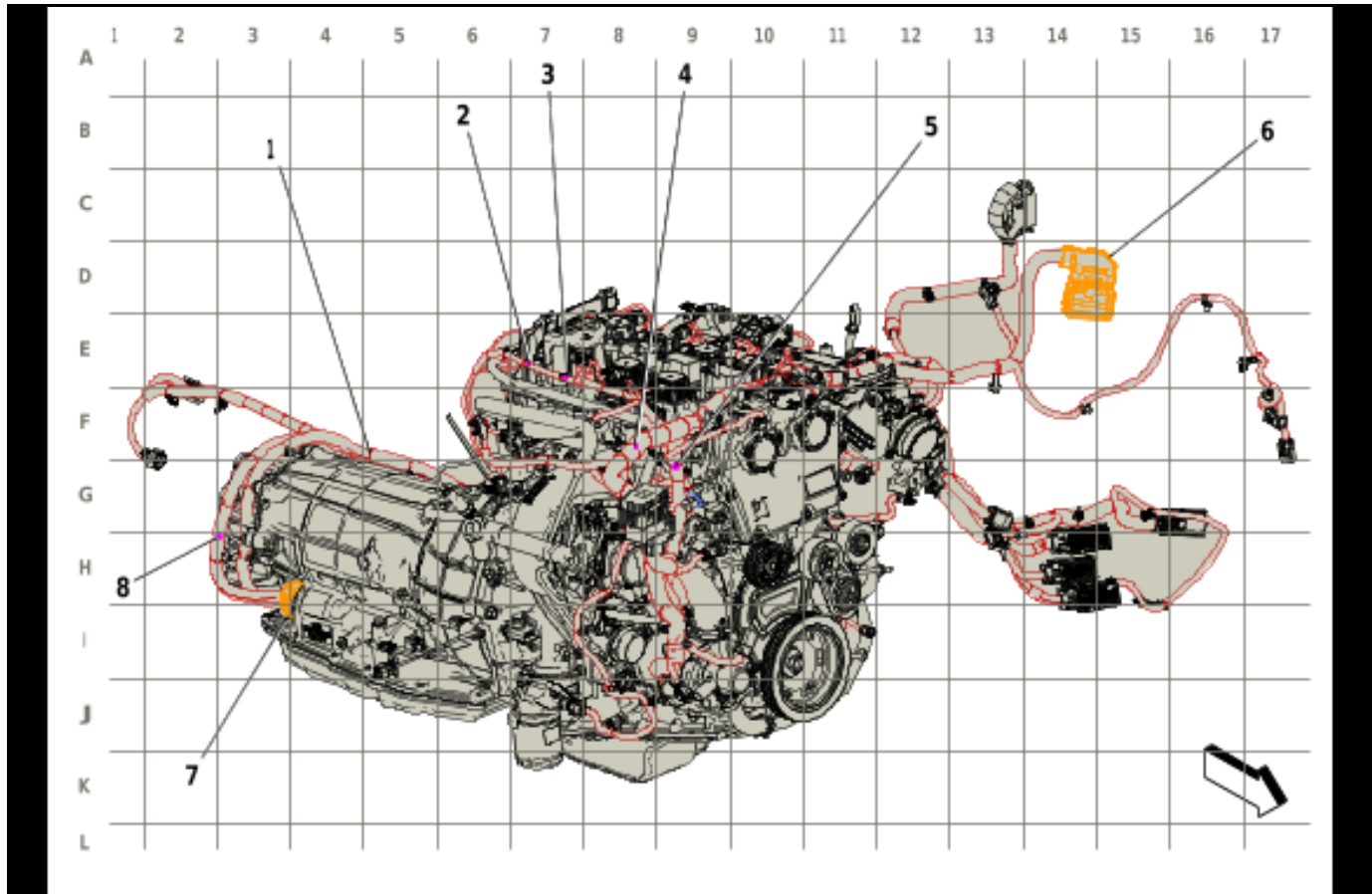

5970772

**Items**

- |  |  |
|--|--|
| (1) J154 Engine Wiring Harness               | (6) X125 Engine Wiring Harness to Body Wiring Harness  |
| (2) J177 Engine Wiring Harness (L3B)         | (7) X175 Engine Wiring Harness to Automatic Transmission Wiring Harness - Case (MHS/MQC/MQE) |
| (3) J163 Engine Wiring Harness (L3B/L84/L87) | (8) J165 Engine Wiring Harness (L3B)   |
| (4) J152 Engine Wiring Harness               |  |
| (5) J179 Engine Wiring Harness (L3B)         |  |

Harness Routing Views (Engine Compartment - Engine Wiring Harness - Left Rear (L84 / L87))

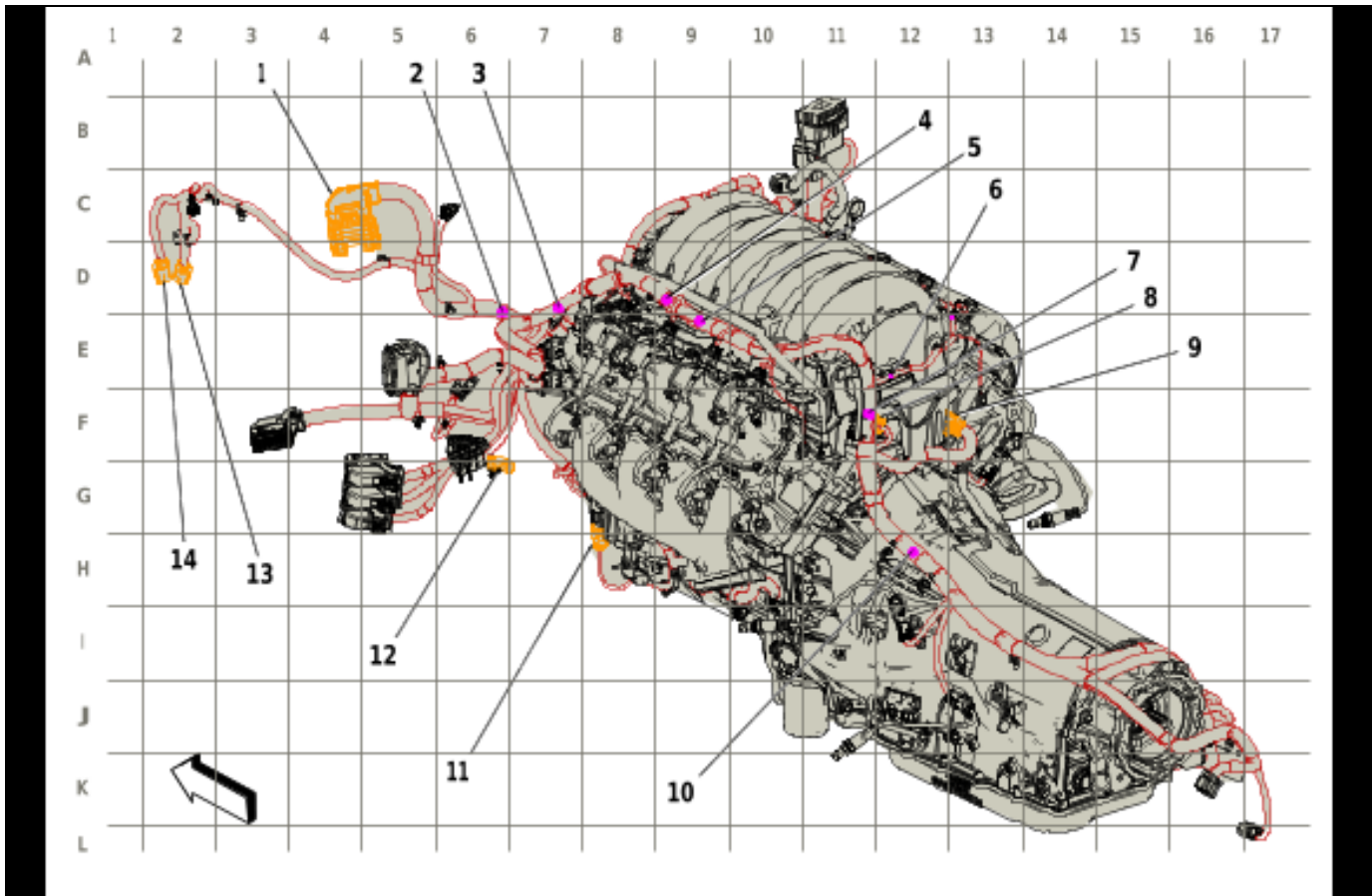

5970773

**Items**

- |  |   |
|--|---|
| <ul style="list-style-type: none"> <li>(1) X125 Engine Wiring Harness to Body Wiring Harness</li> <li>(2) J154 Engine Wiring Harness</li> <li>(3) J153 Engine Wiring Harness</li> <li>(4) J158 Engine Wiring Harness (L3B/L84/L87)</li> <li>(5) J159 Engine Wiring Harness (L84/L87)</li> <li>(6) J160 Engine Wiring Harness (L84/L87)</li> <li>(7) J163 Engine Wiring Harness (L3B/L84/L87)</li> <li>(8) X160 Engine Wiring Harness to Fuel Injector Wiring Harness</li> <li>(9) X161 Engine Wiring Harness to Fuel Injector Wiring Harness - Bank 2 (L84/L87)</li> </ul> | <ul style="list-style-type: none"> <li>(10) J164 Engine Wiring Harness</li> <li>(11) X128 Engine Wiring Harness to Camshaft Position Sensor Wire (L84/L87)</li> <li>(12) X415B Chassis Wiring Harness to Front Wheel Speed Sensor Wiring Harness (JBP)</li> <li>(13) X618A Engine Wiring Harness to Active Grille Air Shutter Wiring Harness (VTI/WMI)</li> <li>(14) X618L Active Grille Air Shutter Jumper Wiring Harness to Active Grille Air Shutter Wiring Harness (WMI)</li> </ul> |
|--|---|



Harness Routing Views (Engine Compartment - Engine Wiring Harness - Right Front (L84 / L87))

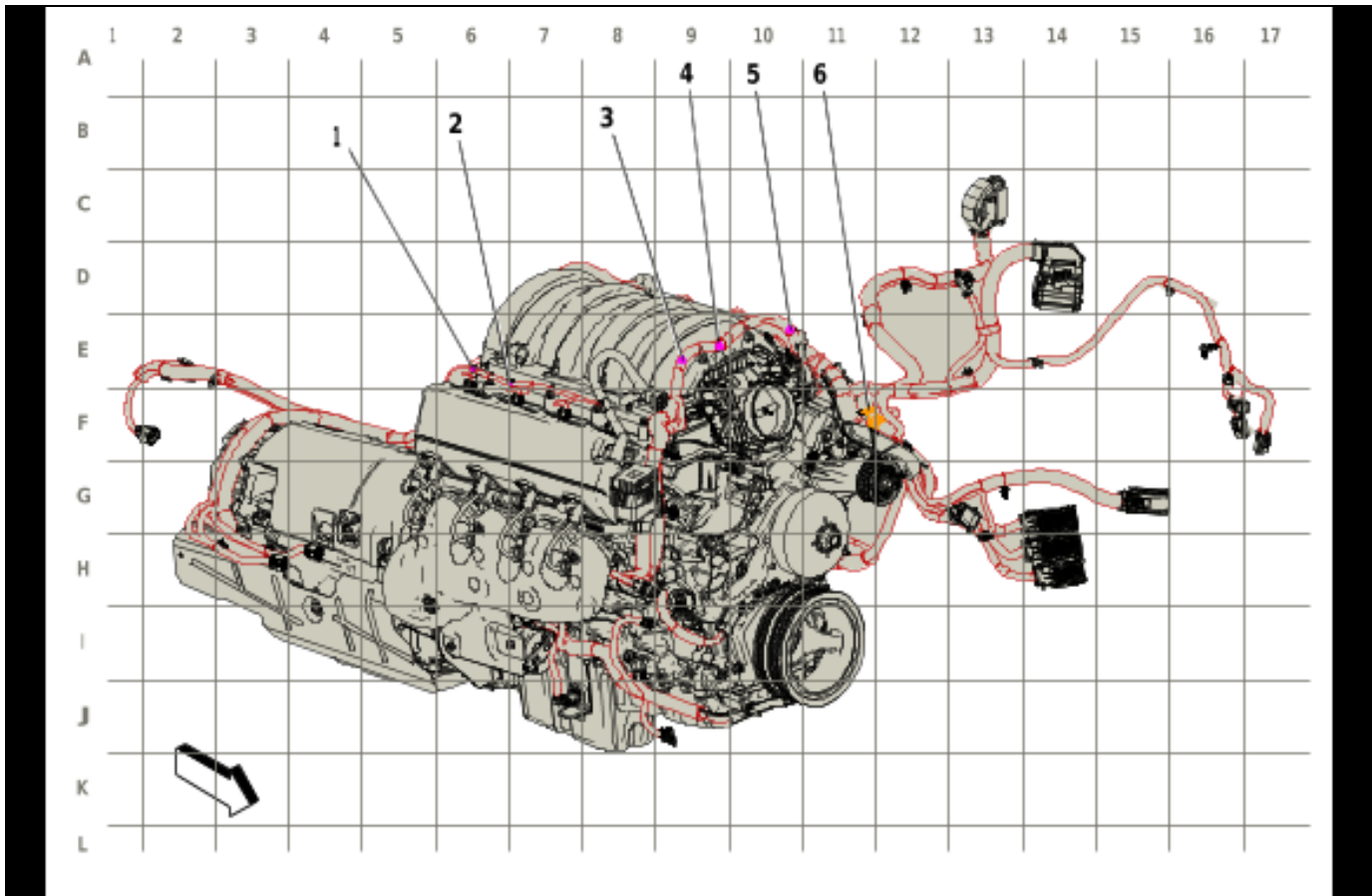

5970774

**Items**

- |  |  |
|--|--|
| <ul style="list-style-type: none"> <li>(1) J161 Engine Wiring Harness (L84/L87)</li> <li>(2) J162 Engine Wiring Harness (L84/L87)</li> <li>(3) J157 Engine Wiring Harness</li> <li>(4) J156 Engine Wiring Harness (L3B/L84/L87)</li> <li>(5) J155 Engine Wiring Harness (L3B/L84/L87)</li> </ul> | <ul style="list-style-type: none"> <li>(6) X962 Engine Wiring Harness to Valve Rocker Arm Oil Control Valve Extension Harness (L84/L87)</li> </ul> |
|--|--|

Harness Routing Views (Engine Compartment - Camshaft Position Sensor Wire (L84 / L87))

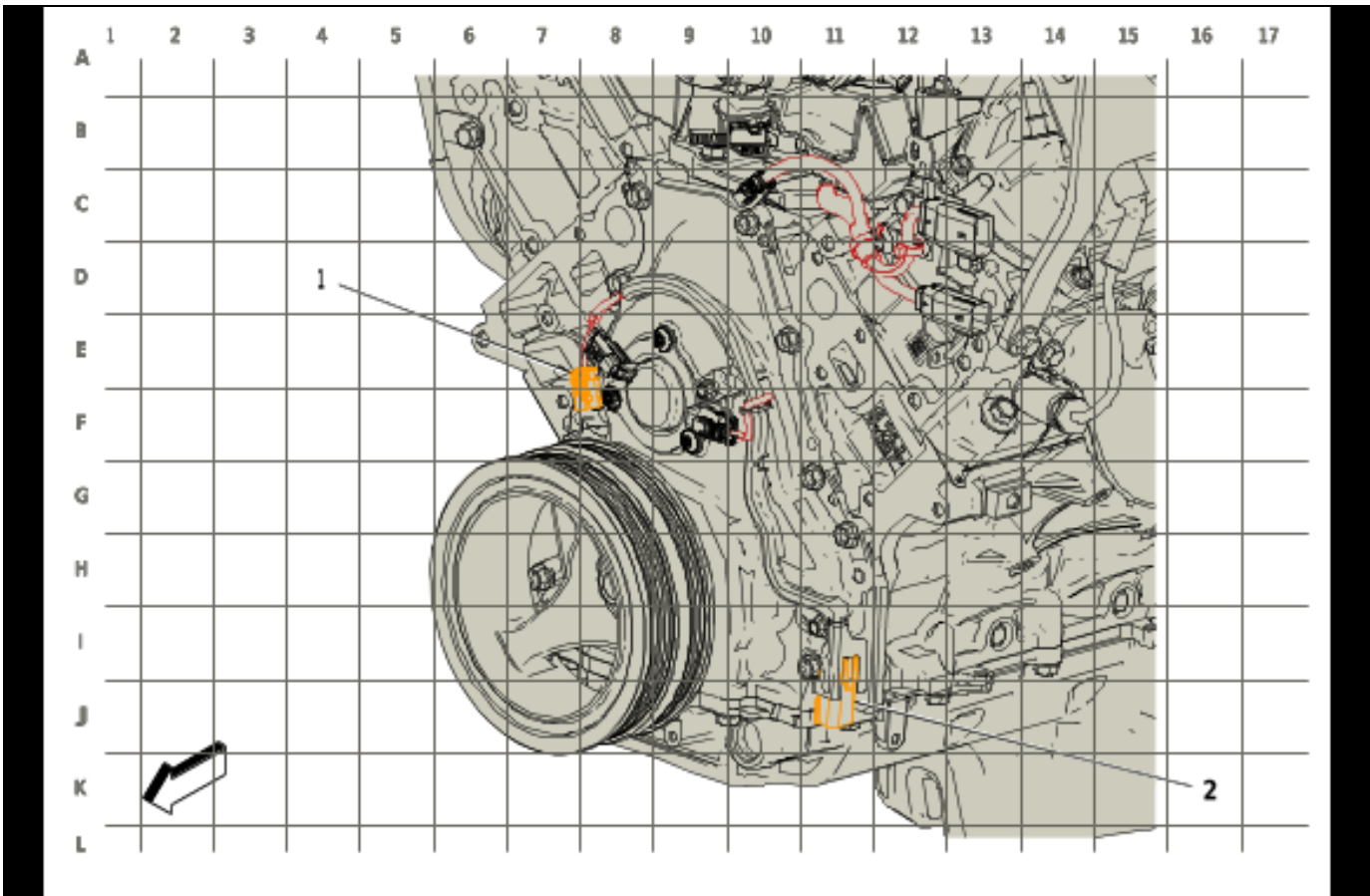

6050071

**Items**

(1) X129 Camshaft Position Sensor Wire to Oil Pump Flow Control Solenoid Valve Wire (L3B/L87/LZ0)

(2) X128 Engine Wiring Harness to Camshaft Position Sensor Wire (L84/L87)

Harness Routing Views (Engine Compartment - Valve Rocker Arm Oil Valve Extension Harness (L84 / L87))

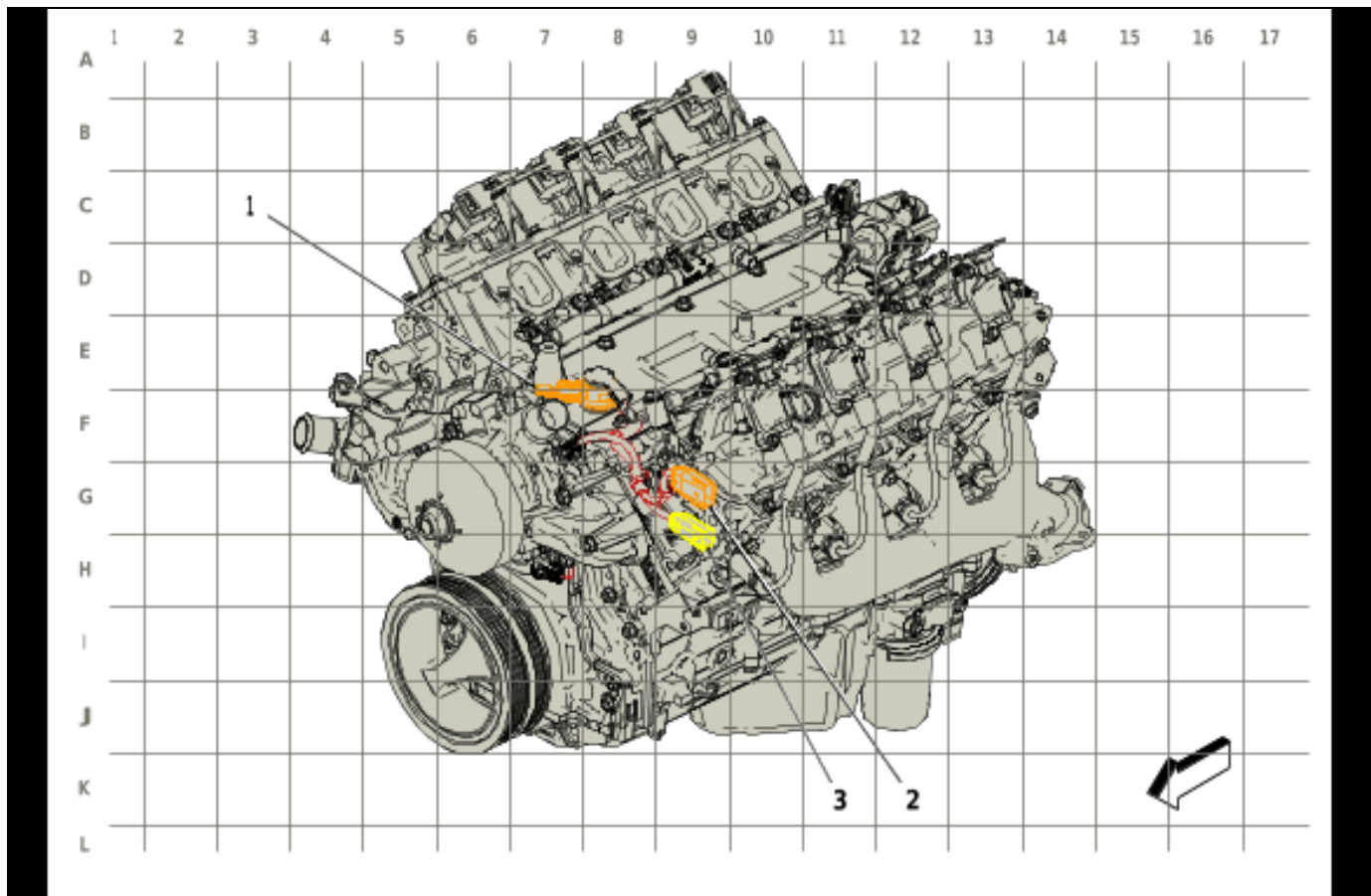

6050073

**Items**

- |  |   |
|--|---|
| <p>(1) X963 Valve Rocker Arm Oil Control Valve Extension Harness to Valve Rocker Arm Oil Control Valve Harness (L84/L87)</p> <p>(2) X962 Engine Wiring Harness to Valve Rocker Arm Oil Control Valve Extension Harness (L84/L87)</p> | <p>(3) X961 Engine Wiring Harness to Valve Rocker Arm Oil Control Valve Extension Harness (L84/L87)</p> |
|--|---|

Harness Routing Views (Engine Compartment - Engine Wiring Harness - Left Rear (LZ0))

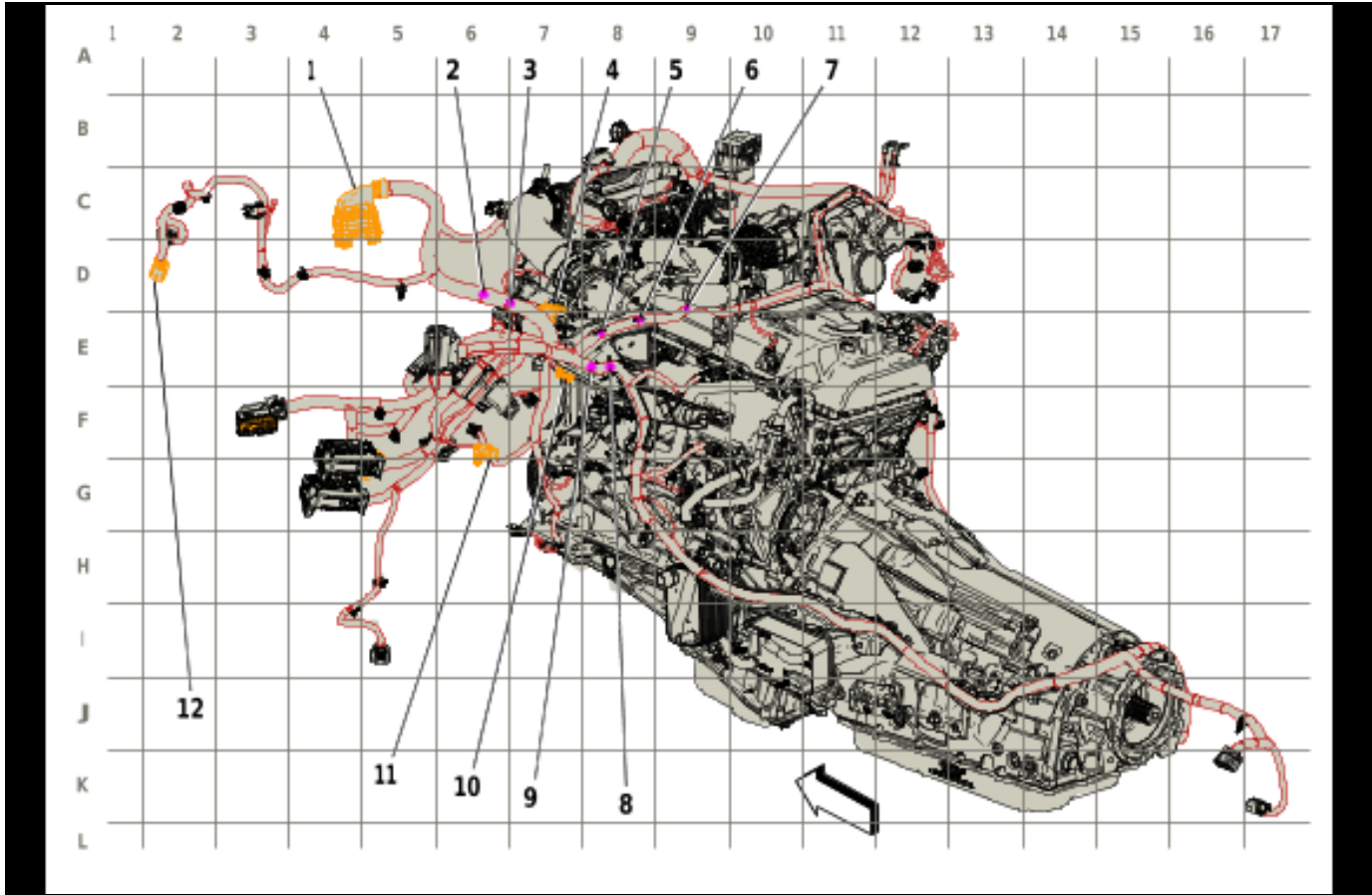

6141575

**Items**

- |     |   |      |   |
|-----|---|------|---|
| (1) | X125 Engine Wiring Harness to Body Wiring Harness                   | (9)  | J180 Engine Wiring Harness (LZ0)  |
| (2) | J153 Engine Wiring Harness  | (10) | X944 Engine Wiring Harness to Engine Coolant Temperature Sensor Harness (LZ0)   |
| (3) | J181 Engine Wiring Harness (LZ0)                                    | (11) | X415A Transfer Case Selector Shift Control Switch Wiring Harness Extension Harness to Engine Wiring Harness (NP0/NQH) |
| (4) | X163 Engine Wiring Harness to Diesel Glow Plug Wiring Harness (LZ0) | (12) | X618A Engine Wiring Harness to Active Grille Air Shutter Wiring Harness (VTI/WMI)                                     |
| (5) | J188 Engine Wiring Harness (LZ0)                                    |      |   |
| (6) | J191 Engine Wiring Harness (LZ0)                                    |      |   |
| (7) | J157 Engine Wiring Harness  |      |   |
| (8) | J151 Engine Wiring Harness  |      |   |

Harness Routing Views (Engine Compartment - Engine Wiring Harness - Right Front (LZ0))

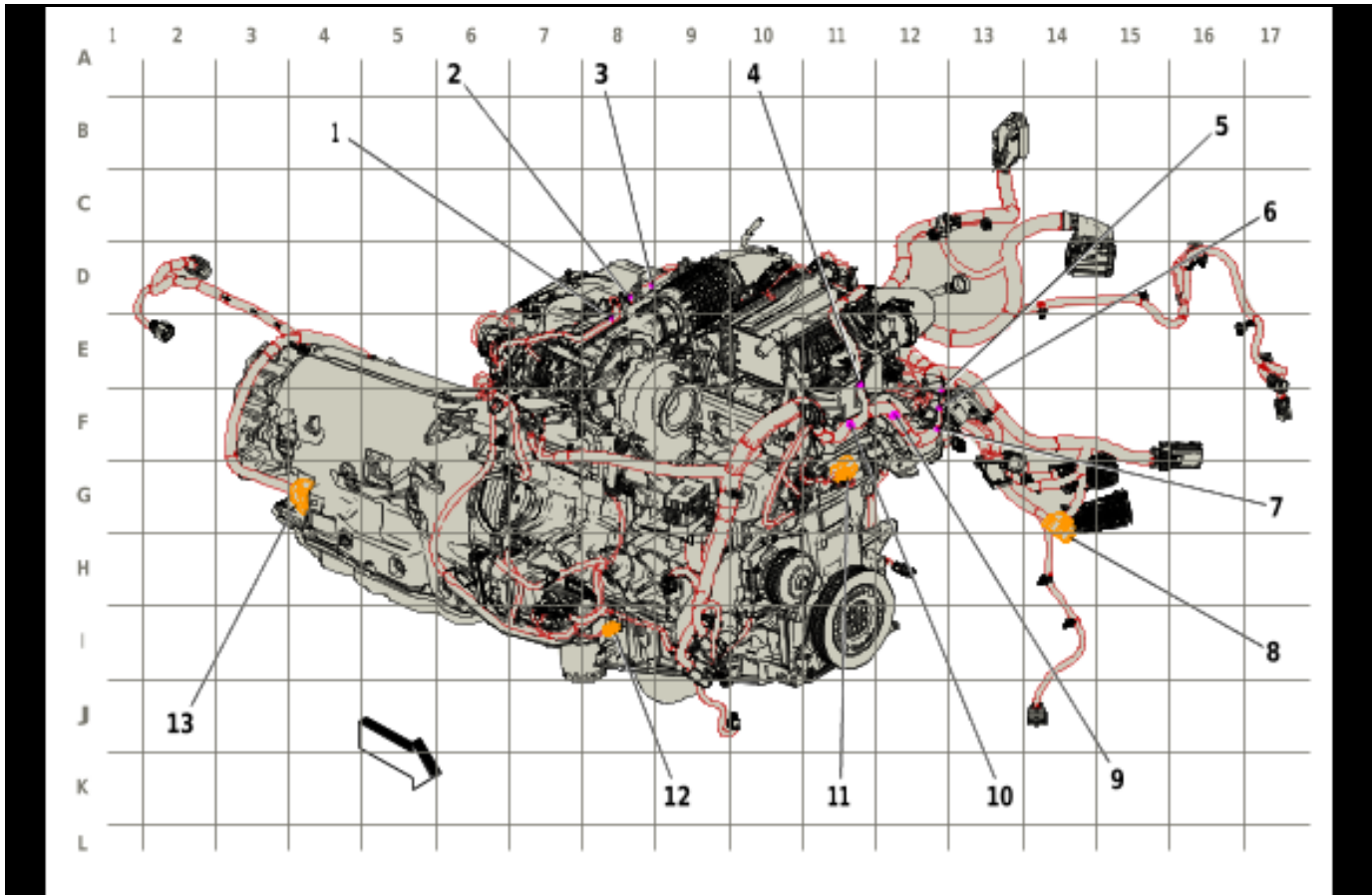

6141574

**Items**

- |     |  |      |   |
|-----|--|------|---|
| (1) | J189 Engine Wiring Harness (LZ0)                           | (10) | J164 Engine Wiring Harness  |
| (2) | J184 Engine Wiring Harness (LZ0)                           | (11) | X160 Engine Wiring Harness to Fuel Injector Wiring Harness                                    |
| (3) | J190 Engine Wiring Harness (LZ0)                           | (12) | X129 Camshaft Position Sensor Wire to Oil Pump Flow Control Solenoid Valve Wire (L3B/L87/LZ0) |
| (4) | J182 Engine Wiring Harness (LZ0)                           | (13) | X175 Engine Wiring Harness to Automatic Transmission Wiring Harness - Case (MHS/MQC/MQE)      |
| (5) | J154 Engine Wiring Harness                                 |      |   |
| (6) | J150 Engine Wiring Harness                                 |      |   |
| (7) | J186 Engine Wiring Harness (LZ0)                           |      |   |
| (8) | X401 Engine Wiring Harness to Chassis Wiring Harness (LZ0) |      |   |
| (9) | J152 Engine Wiring Harness                                 |      |   |



Harness Routing Views (Engine Compartment - Power Steering Wiring Harness Extension Harness)

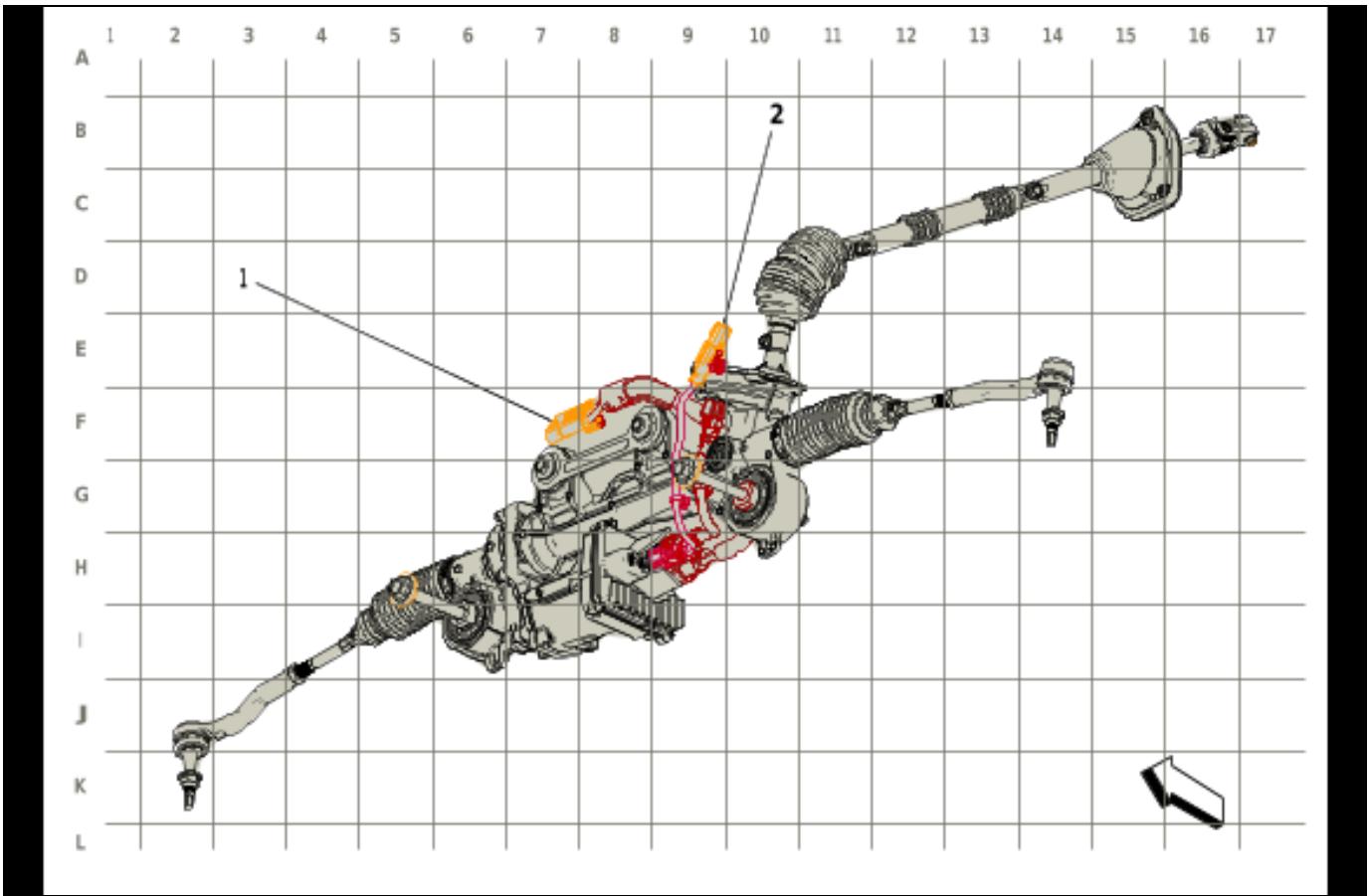

5970778

**Items**

(1) X405 Power Steering Wiring Harness to Power Steering Control Module Wiring Harness

(2) X403 Chassis Wiring Harness to Power Steering Wiring Harness Extension Harness

Harness Routing Views (Instrument Panel Wiring Harness (IOK))

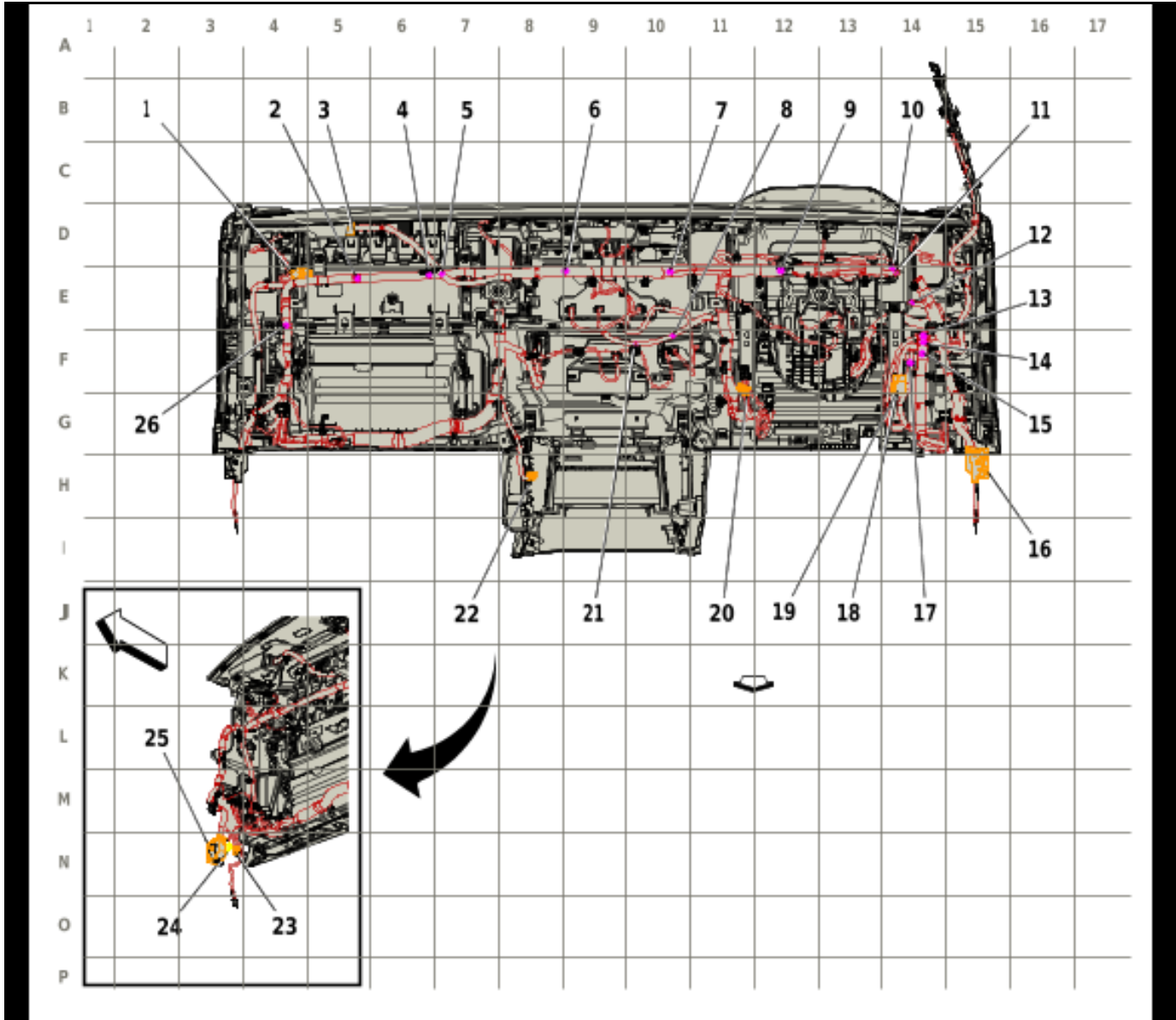

5965518

**Items**

- |      |  |      |   |
|------|--|------|---|
| (1)  | X237 Instrument Panel Wiring Harness to Instrument Panel Airbag Wiring Harness | (13) | J225 Instrument Panel Wiring Harness  |
| (2)  | J241 Instrument Panel Wiring Harness   | (14) | J226 Instrument Panel Wiring Harness  |
| (3)  | X370 Dome Lamp Wiring Harness to Instrument Panel Wiring Harness               | (15) | J227 Instrument Panel Wiring Harness  |
| (4)  | J240 Instrument Panel Wiring Harness   | (16) | X210 Instrument Panel Wiring Harness to Body Wiring Harness                                 |
| (5)  | J239 Instrument Panel Wiring Harness   | (17) | J228 Instrument Panel Wiring Harness (JHD)  |
| (6)  | J238 Instrument Panel Wiring Harness   | (18) | X213A Auxiliary Fuse Block Wiring Harness to Instrument Panel Wiring Harness (9L7)          |
| (7)  | J235 Instrument Panel Wiring Harness   | (19) | X213B Trailer Wiring Harness Extension Harness to Instrument Panel Wiring Harness (Z82-JL1) |
| (8)  | J236 Instrument Panel Wiring Harness   | (20) | X250 Instrument Panel Wiring Harness to Heater Wiring Harness                               |
| (9)  | J233 Instrument Panel Wiring Harness (UV6)                                     | (21) | J237 Instrument Panel Wiring Harness  |
| (10) | J231 Instrument Panel Wiring Harness (9L7 +(G93/G94))                          | (22) | X226 Front Floor Console Wiring Harness to Instrument Panel Wiring Harness (D07)            |
| (11) | J230 Instrument Panel Wiring Harness   |      |   |
| (12) | J229 Instrument Panel Wiring Harness   |      |   |

- (23) X218 Instrument Panel Wiring Harness to Body Wiring Harness
- (24) X217 Body Wiring Harness to Instrument Panel Wiring Harness

- (25) X211 Instrument Panel Wiring Harness to Body Wiring Harness
- (26) J242 Instrument Panel Wiring Harness

**Harness Routing Views (Instrument Panel Wiring Harness (IOR))**

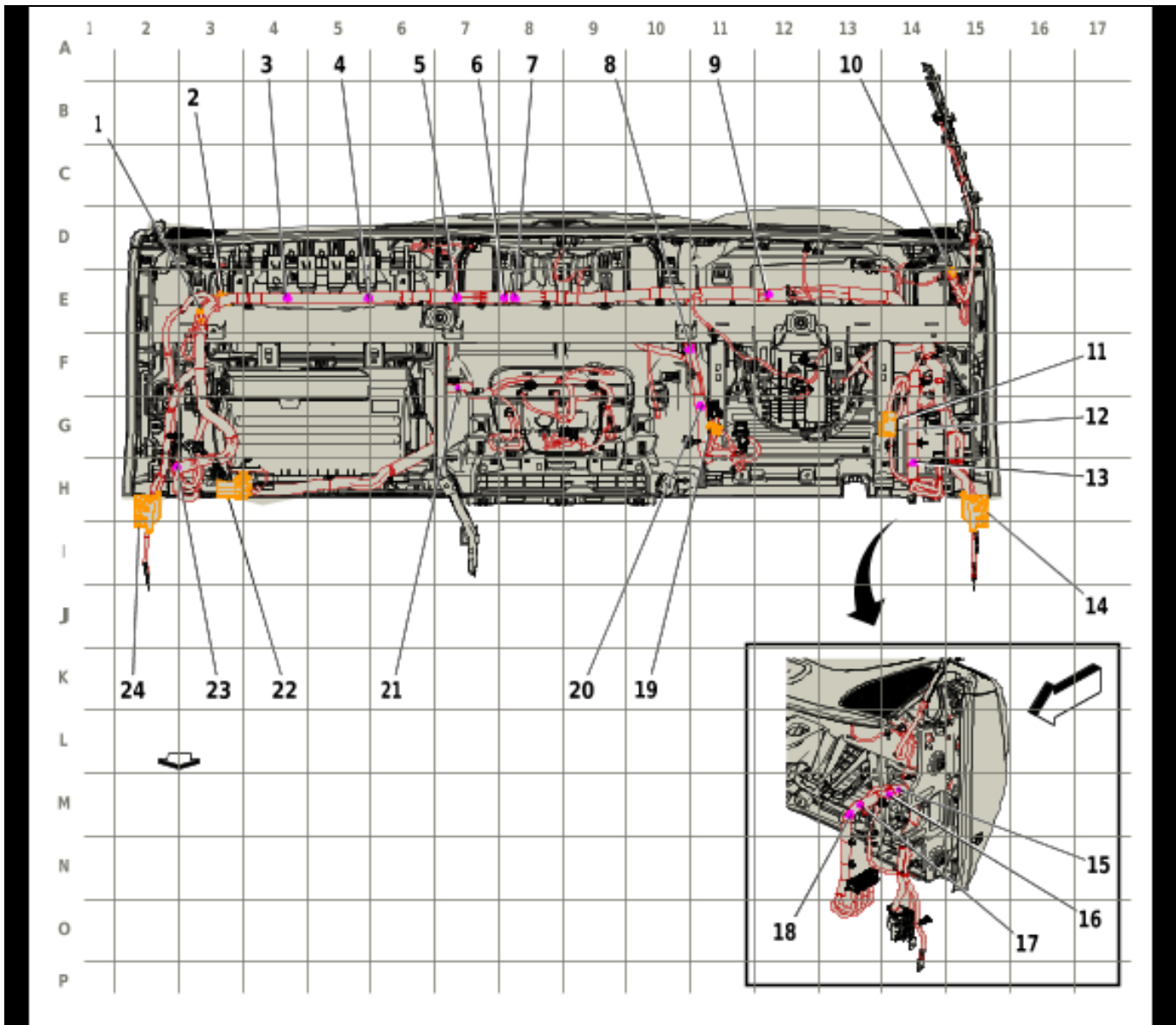

5965519

**Items**

- (1) X220
- (2) X237 Instrument Panel Wiring Harness to Instrument Panel Airbag Wiring Harness
- (3) J241 Instrument Panel Wiring Harness
- (4) J239 Instrument Panel Wiring Harness
- (5) J237 Instrument Panel Wiring Harness
- (6) J236 Instrument Panel Wiring Harness
- (7) J238 Instrument Panel Wiring Harness
- (8) J230 Instrument Panel Wiring Harness

- (9) J226 Instrument Panel Wiring Harness
- (10) X219
- (11) X213A Auxiliary Fuse Block Wiring Harness to Instrument Panel Wiring Harness (9L7)
- (12) X213B Trailer Wiring Harness Extension Harness to Instrument Panel Wiring Harness (Z82-JL1)
- (13) J235 Instrument Panel Wiring Harness
- (14) X210 Instrument Panel Wiring Harness to Body Wiring Harness



- |  |   |
|--|---|
| (15) J227 Instrument Panel Wiring Harness                          | (21) J228 Instrument Panel Wiring Harness (JHD)                       |
| (16) J229 Instrument Panel Wiring Harness                          | (22) X370 Dome Lamp Wiring Harness to Instrument Panel Wiring Harness |
| (17) J225 Instrument Panel Wiring Harness                          | (23) J242 Instrument Panel Wiring Harness                             |
| (18) J240 Instrument Panel Wiring Harness                          | (24) X211 Instrument Panel Wiring Harness to Body Wiring Harness      |
| (19) X250 Instrument Panel Wiring Harness to Heater Wiring Harness |   |
| (20) J234 Instrument Panel Wiring Harness                          |   |

**Harness Routing Views (Instrument Panel - Steering Wheel Horn Switch Wiring Harness)**

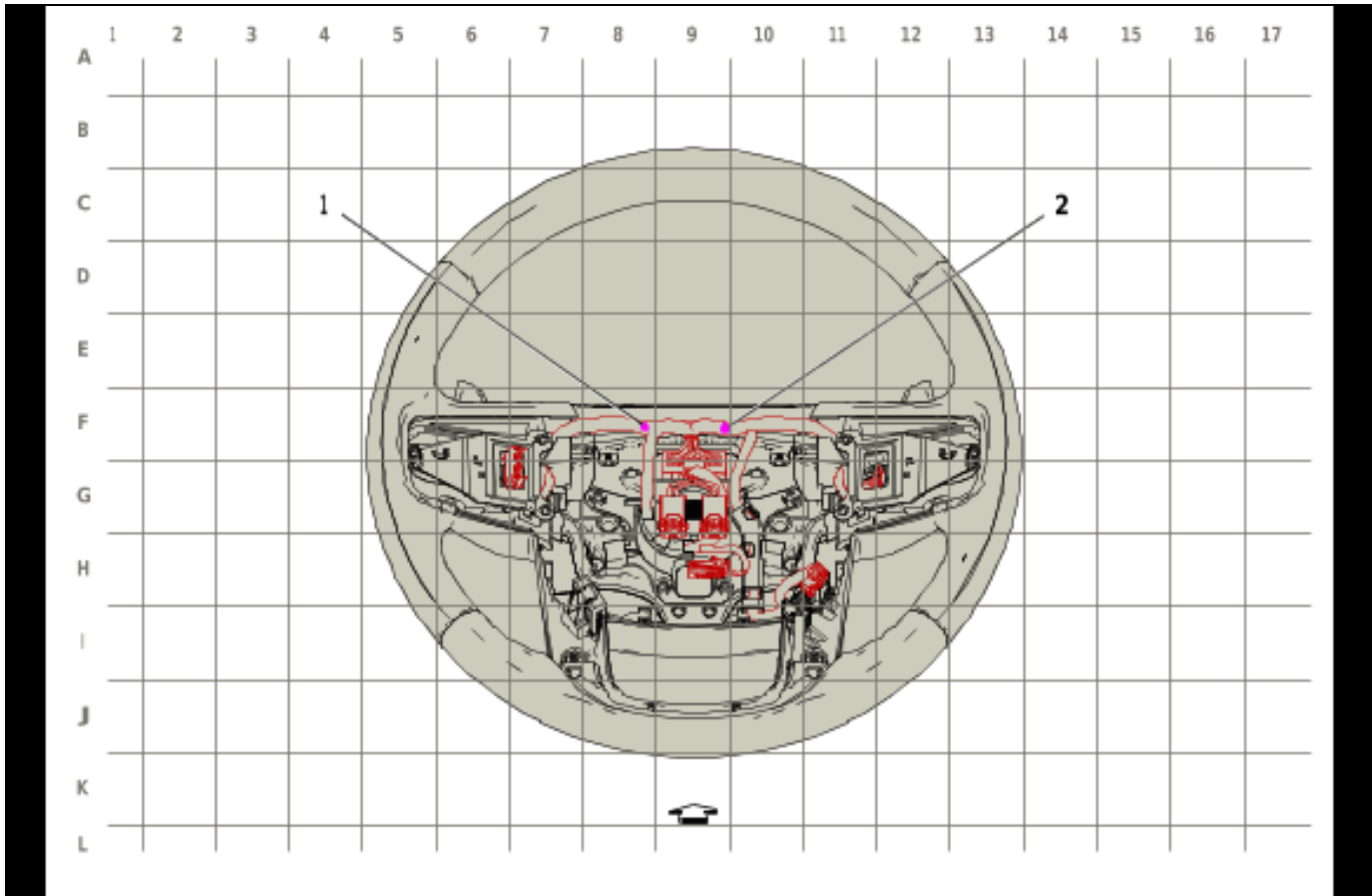

6050075

**Items**

- |  |  |
|--|--|
| (1) J251 Steering Wheel Horn Switch Wiring Harness (UK3) | (2) J250 Steering Wheel Horn Switch Wiring Harness (UK3) |
|--|--|

Harness Routing Views (Instrument Panel - Heater Wiring Harness)

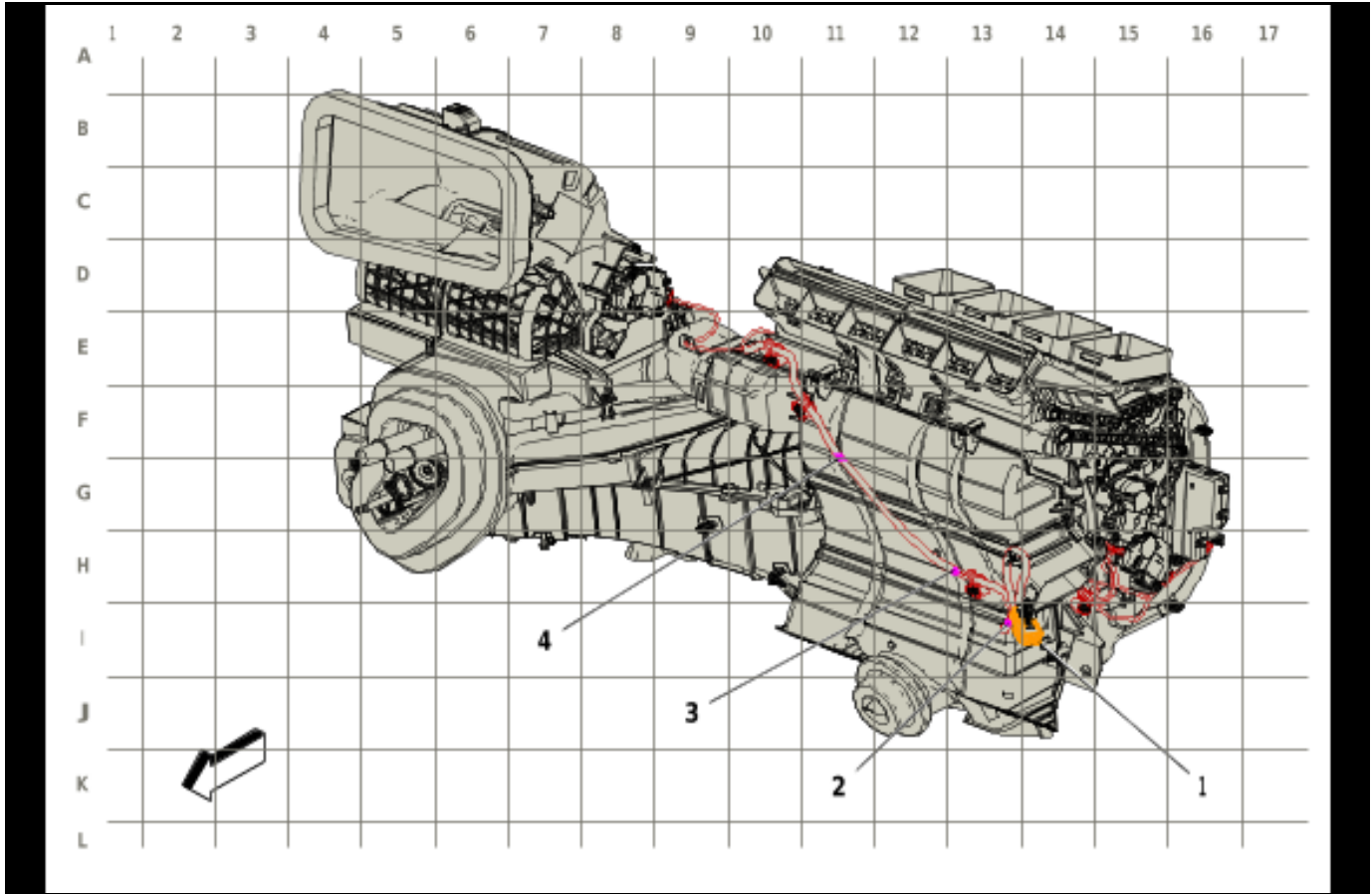

6050077

**Items**

- (1) X250 Instrument Panel Wiring Harness to Heater Wiring Harness
- (2) J220 Heater Wiring Harness
- (3) J222 Heater Wiring Harness
- (4) J221 Heater Wiring Harness

Harness Routing Views (Passenger Compartment - Body Wiring Harness - Left Front - Regular Cab)

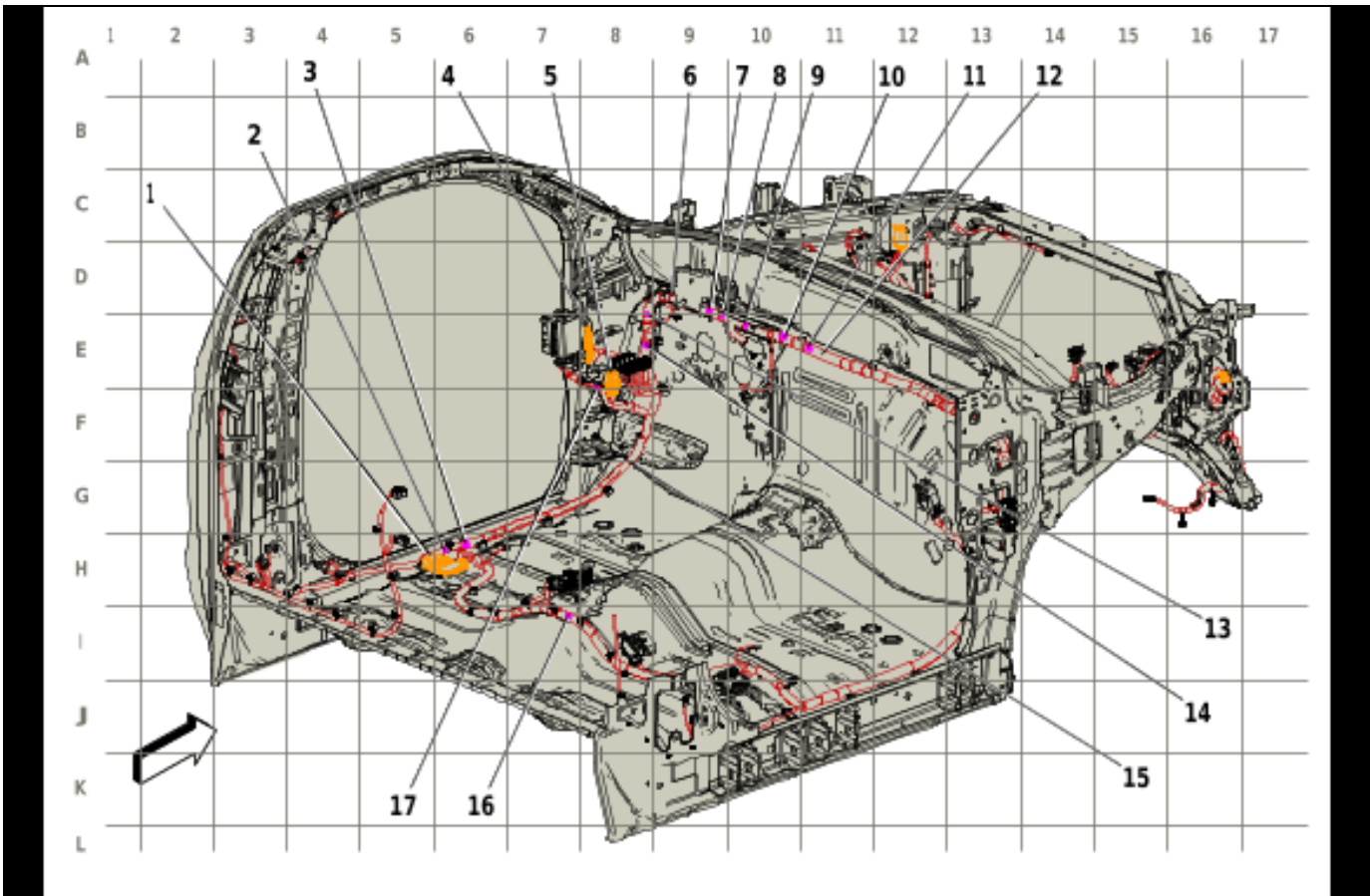

6282850

**Items**

- |     |  |      |                                    |
|-----|--|------|------------------------------------|
| (1) | X331 Front Seat Wiring Harness - Driver to Body Wiring Harness           | (9)  | J209 Body Wiring Harness           |
| (2) | J300 Body Wiring Harness   | (10) | J210 Body Wiring Harness           |
| (3) | J302 Body Wiring Harness   | (11) | J211 Body Wiring Harness           |
| (4) | X500 Front Side Door Door Wiring Harness - Driver to Body Wiring Harness | (12) | J306 Body Wiring Harness           |
| (5) | X210 Instrument Panel Wiring Harness to Body Wiring Harness              | (13) | J204 Body Wiring Harness (KC9/KCA) |
| (6) | J205 Body Wiring Harness   | (14) | J203 Body Wiring Harness (LZ0)     |
| (7) | J207 Body Wiring Harness   | (15) | J200 Body Wiring Harness (LZ0)     |
| (8) | J208 Body Wiring Harness   | (16) | J308 Body Wiring Harness           |
|     |  | (17) | J201 Body Wiring Harness (FHX)     |

Harness Routing Views (Passenger Compartment - Body Wiring Harness - Left Front - Double Cab/Crew Cab)

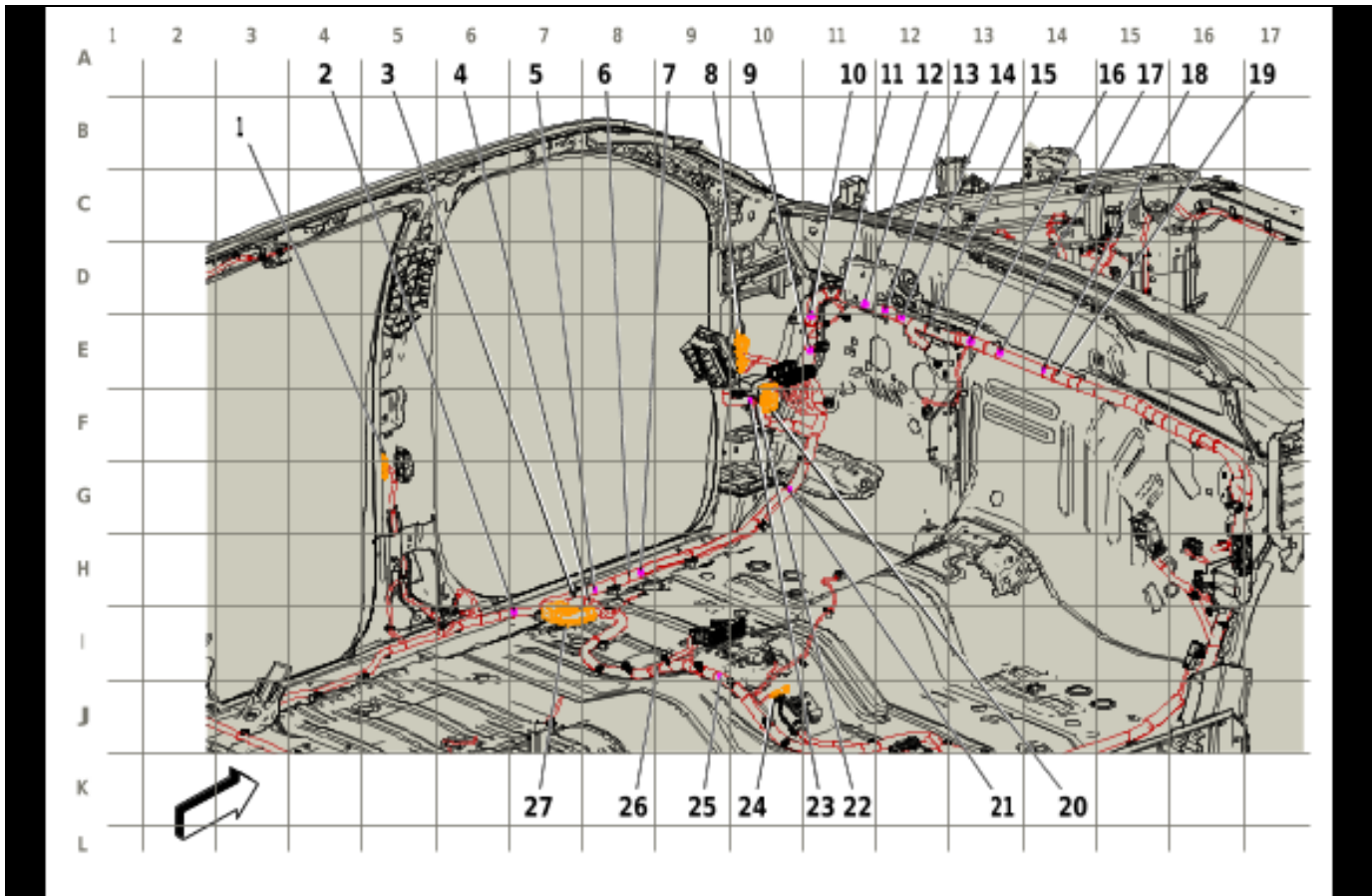

5965521

**Items**

- |      |  |      |  |
|------|--|------|--|
| (1)  | X700 Rear Side Door Door Wiring Harness - Left to Body Wiring Harness (Double Cab/ Crew Cab) | (15) | J209 Body Wiring Harness   |
| (2)  | J311 Body Wiring Harness   | (16) | J210 Body Wiring Harness   |
| (3)  | J303 Body Wiring Harness   | (17) | J211 Body Wiring Harness   |
| (4)  | J306 Body Wiring Harness   | (18) | J212 Body Wiring Harness   |
| (5)  | J302 Body Wiring Harness   | (19) | J213 Body Wiring Harness   |
| (6)  | J301 Body Wiring Harness   | (20) | X210 Instrument Panel Wiring Harness to Body Wiring Harness          |
| (7)  | J300 Body Wiring Harness   | (21) | J200 Body Wiring Harness (LZ0)                                       |
| (8)  | X500 Front Side Door Door Wiring Harness - Driver to Body Wiring Harness                     | (22) | J201 Body Wiring Harness (FHX)                                       |
| (9)  | J203 Body Wiring Harness (LZ0)   | (23) | J202 Body Wiring Harness (BRS)                                       |
| (10) | J204 Body Wiring Harness (KC9/KCA)   | (24) | X225 Front Floor Console Wiring Harness to Body Wiring Harness (D07) |
| (11) | J205 Body Wiring Harness   | (25) | J308 Body Wiring Harness   |
| (12) | J206 Body Wiring Harness   | (26) | J307 Body Wiring Harness   |
| (13) | J207 Body Wiring Harness   | (27) | X331 Front Seat Wiring Harness - Driver to Body Wiring Harness       |
| (14) | J208 Body Wiring Harness   |      |  |

Harness Routing Views (Passenger Compartment - Body Wiring Harness - Left Rear - Regular Cab)

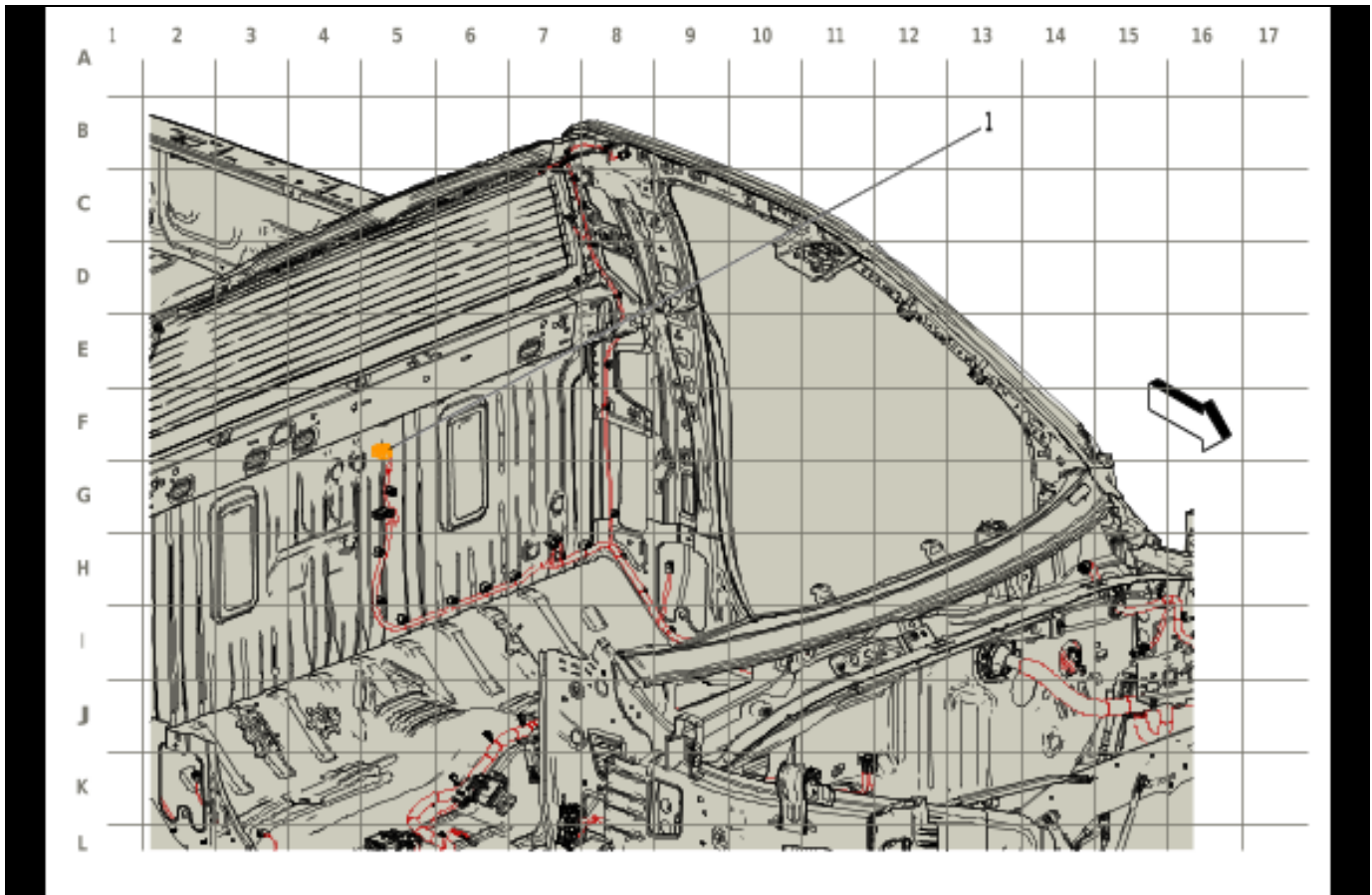

5965522

**Items**

- (1) X324 Body Wiring Harness to Body Rear Wiring Harness Extension Harness (KI5)



Harness Routing Views (Passenger Compartment - Body Wiring Harness - Left Rear - Double Cab/Crew Cab)

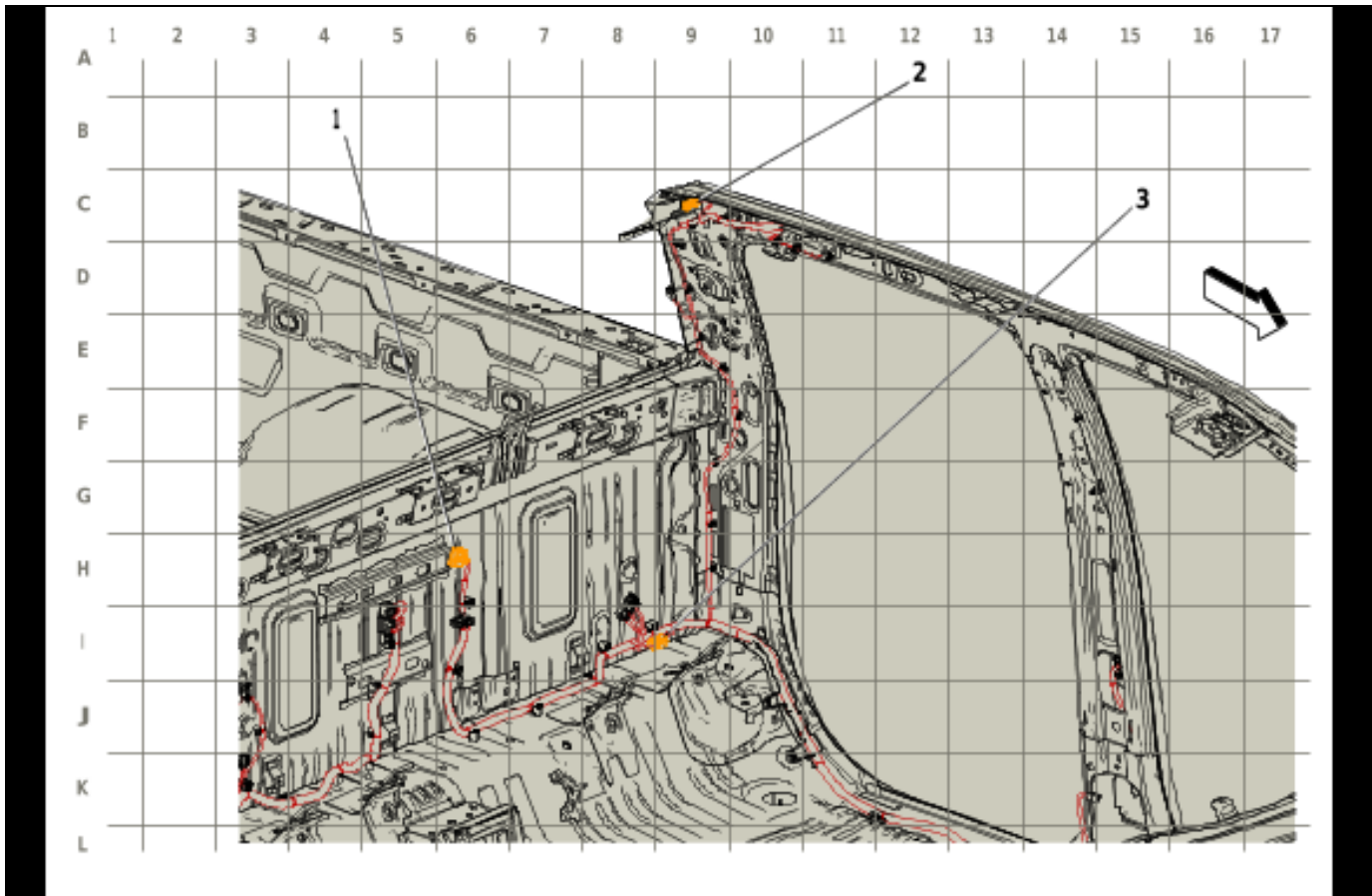

5965523

**Items**

- (1) X324 Body Wiring Harness to Body Rear Wiring Harness Extension Harness (KI5)
- (2) X309 Body Wiring Harness to Inside Rearview Mirror Wiring Harness - Jumper (UVN)
- (3) X340 Body Wiring Harness to Rear Seat Heater Control Wiring Harness (KA6)

Harness Routing Views (Passenger Compartment - Body Wiring Harness - Right Front - Regular Cab)

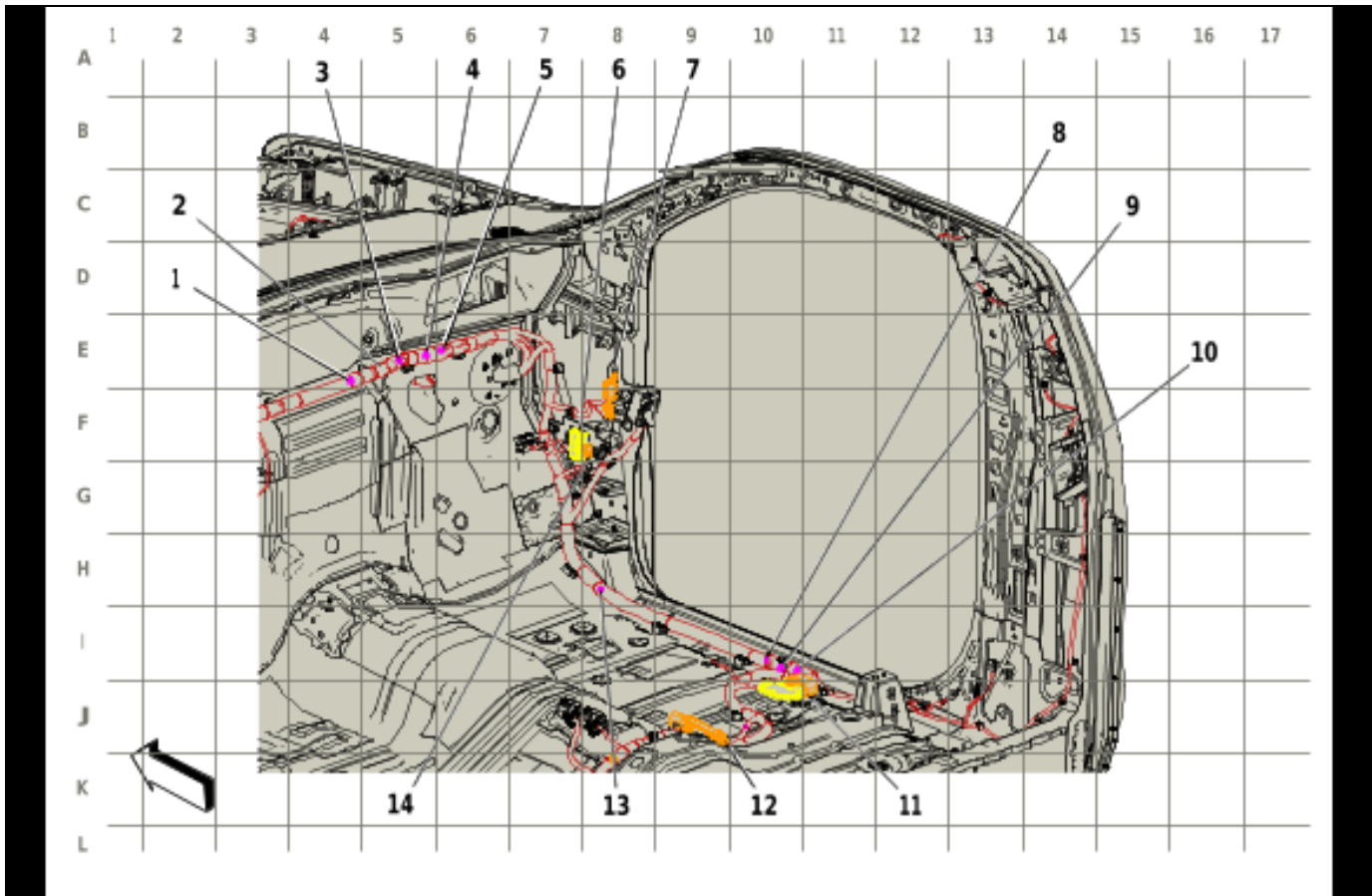

5965524

**Items**

- |     |   |      |   |
|-----|---|------|---|
| (1) | J212 Body Wiring Harness  | (9)  | J310 Body Wiring Harness  |
| (2) | J215 Body Wiring Harness  | (10) | J305 Body Wiring Harness  |
| (3) | J213 Body Wiring Harness  | (11) | X336 Front Seat Wiring Harness - Passenger to Body Wiring Harness |
| (4) | J218 Body Wiring Harness  | (12) | X227 Front Floor Console Wiring Harness to Body Wiring Harness    |
| (5) | J217 Body Wiring Harness  | (13) | J314 Body Wiring Harness  |
| (6) | X211 Instrument Panel Wiring Harness to Body Wiring Harness                 | (14) | X217 Body Wiring Harness to Instrument Panel Wiring Harness       |
| (7) | X600 Front Side Door Door Wiring Harness - Passenger to Body Wiring Harness |      |   |
| (8) | J304 Body Wiring Harness  |      |   |

**Harness Routing Views (Passenger Compartment - Body Wiring Harness - Right Front - Double Cab/Crew Cab)**

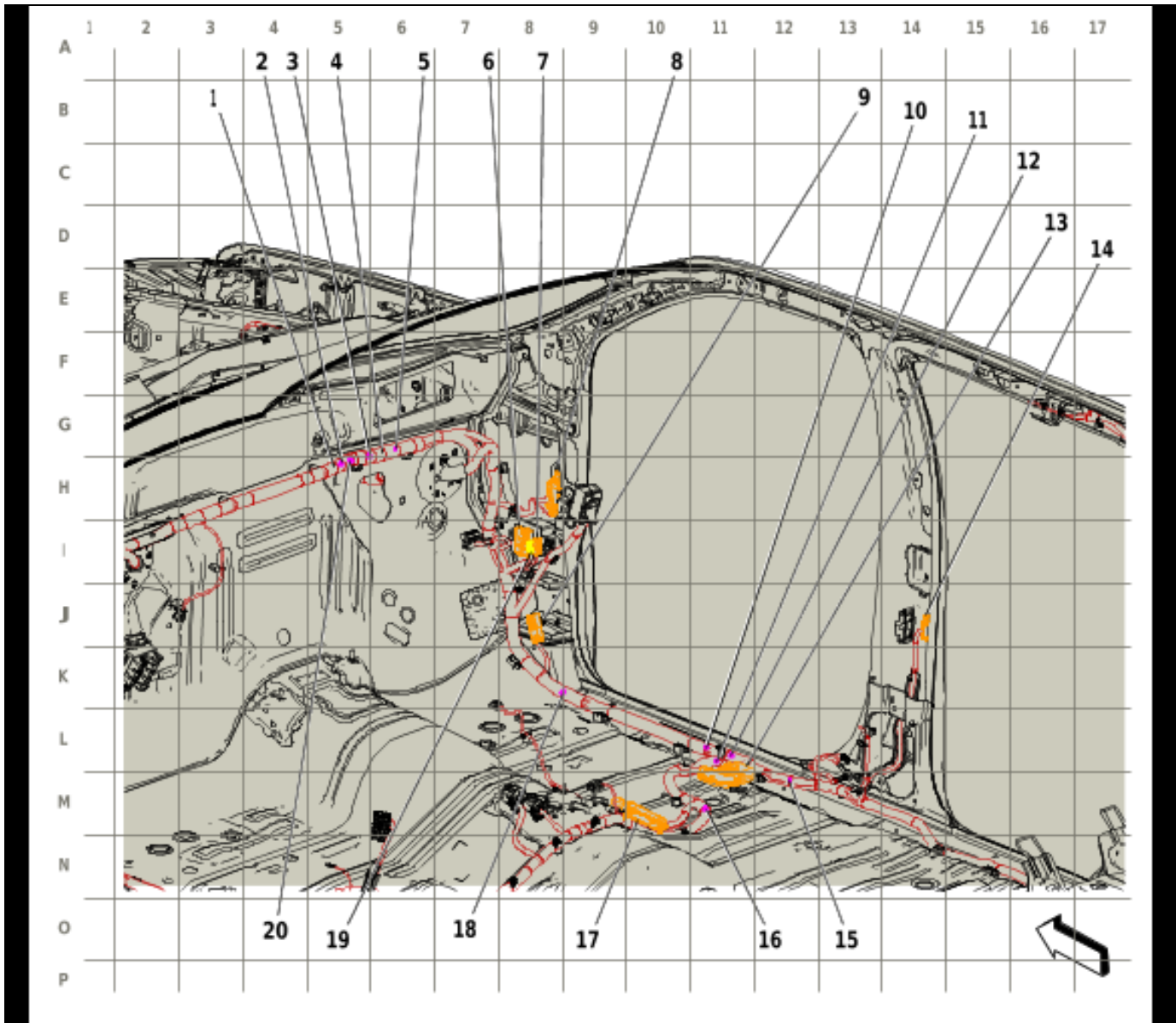

5965525

**Items**

- |   |   |
|---|---|
| (1) J215 Body Wiring Harness  | (11) J310 Body Wiring Harness   |
| (2) J213 Body Wiring Harness  | (12) J305 Body Wiring Harness   |
| (3) J218 Body Wiring Harness  | (13) X336 Front Seat Wiring Harness - Passenger to Body Wiring Harness                            |
| (4) J217 Body Wiring Harness  | (14) X800 Rear Side Door Door Wiring Harness - Right to Body Wiring Harness (Double Cab/Crew Cab) |
| (5) J219 Body Wiring Harness  | (15) J312 Body Wiring Harness   |
| (6) X211 Instrument Panel Wiring Harness to Body Wiring Harness                 | (16) J309 Body Wiring Harness   |
| (7) X218 Instrument Panel Wiring Harness to Body Wiring Harness                 | (17) X227 Front Floor Console Wiring Harness to Body Wiring Harness                               |
| (8) X600 Front Side Door Door Wiring Harness - Passenger to Body Wiring Harness | (18) J314 Body Wiring Harness   |
| (9) X251 HVAC Wiring Harness to Body Wiring Harness (C32)                       | (19) X217 Body Wiring Harness to Instrument Panel Wiring Harness                                  |
| (10) J304 Body Wiring Harness   | (20) J216 Body Wiring Harness   |



Harness Routing Views (Passenger Compartment - Front Seat Wiring Harness - Driver)

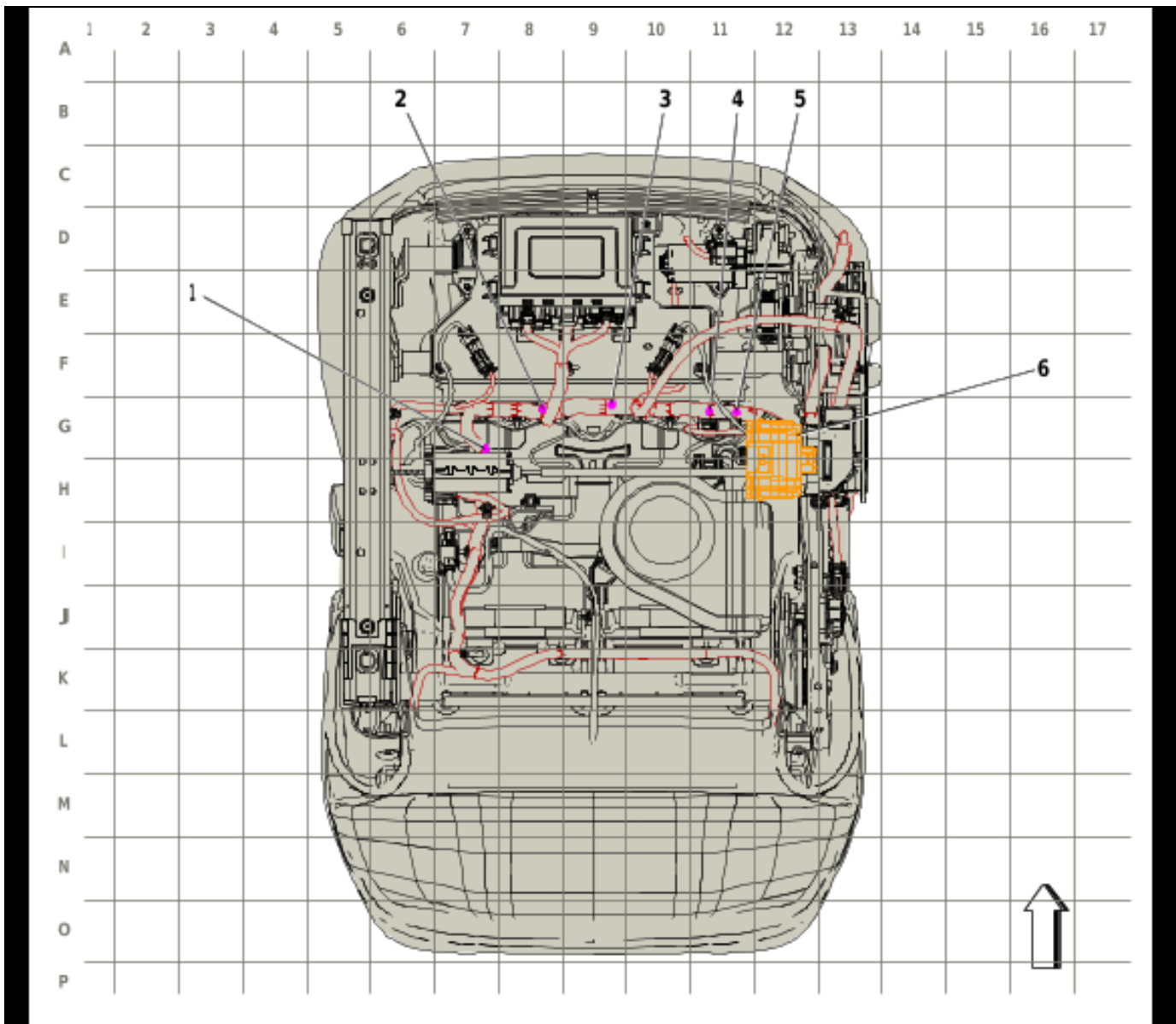

5970779

**Items**

- |  |   |
|--|---|
| <p>(1) J339 Front Seat Wiring Harness - Driver (KA1/KQV)</p> <p>(2) J329 Front Seat Wiring Harness - Driver (KQV)</p> <p>(3) J328 Front Seat Wiring Harness - Driver (A45)</p> | <p>(4) J336 Front Seat Wiring Harness - Driver (KQV)</p> <p>(5) J338 Front Seat Wiring Harness - Driver</p> <p>(6) X331 Front Seat Wiring Harness - Driver to Body Wiring Harness</p> |
|--|---|

Harness Routing Views (Passenger Compartment - Front Seat Wiring Harness - Center (AZ3 - 5Y1))

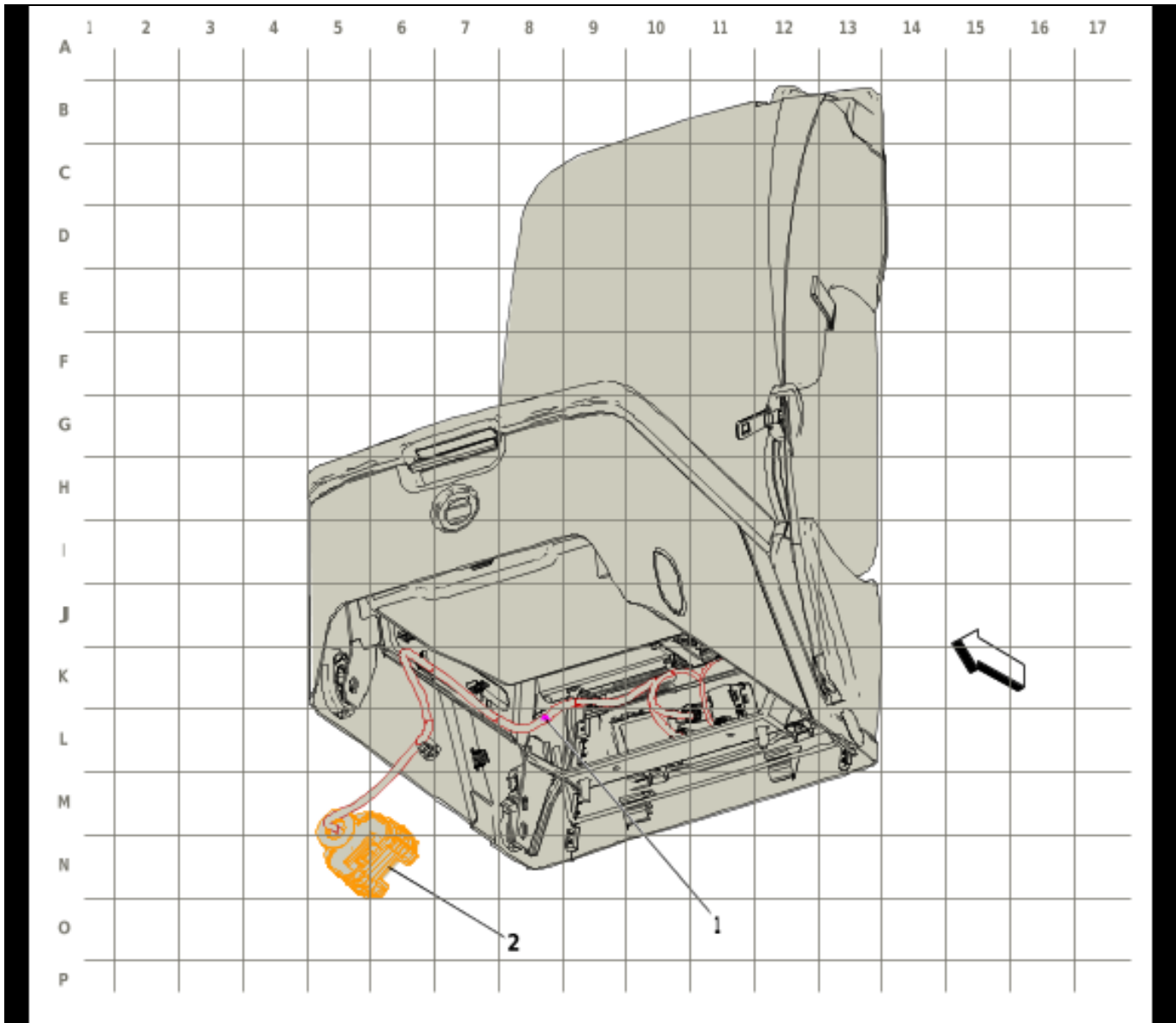

5990989

**Items**

- (1) J345 Front Seat Wiring Harness - Center (AZ3)
- (2) X227 Front Floor Console Wiring Harness to Body Wiring Harness

Harness Routing Views (Passenger Compartment - Front Seat Wiring Harness - Passenger)

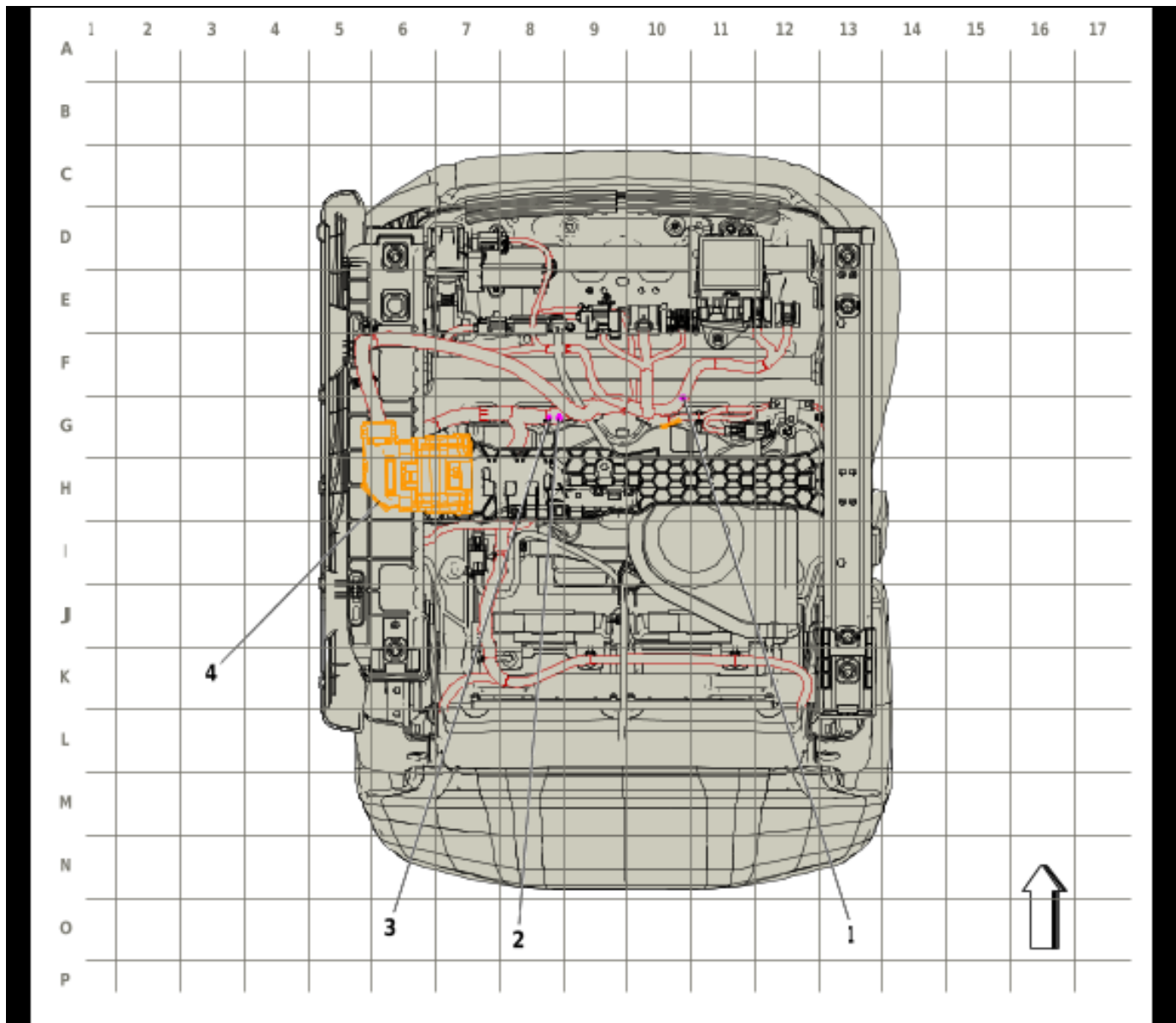

5970780

**Items**

- |  |   |
|--|---|
| <ul style="list-style-type: none"> <li>(1) J349 Front Seat Wiring Harness - Passenger (KQV)</li> <li>(2) J351 Front Seat Wiring Harness - Passenger</li> <li>(3) J352 Front Seat Wiring Harness - Passenger (KA1/KQV)</li> </ul> | <ul style="list-style-type: none"> <li>(4) X336 Front Seat Wiring Harness - Passenger to Body Wiring Harness</li> </ul> |
|--|---|

Harness Routing Views (Passenger Compartment - Front Floor Console Wiring Harness (D07))

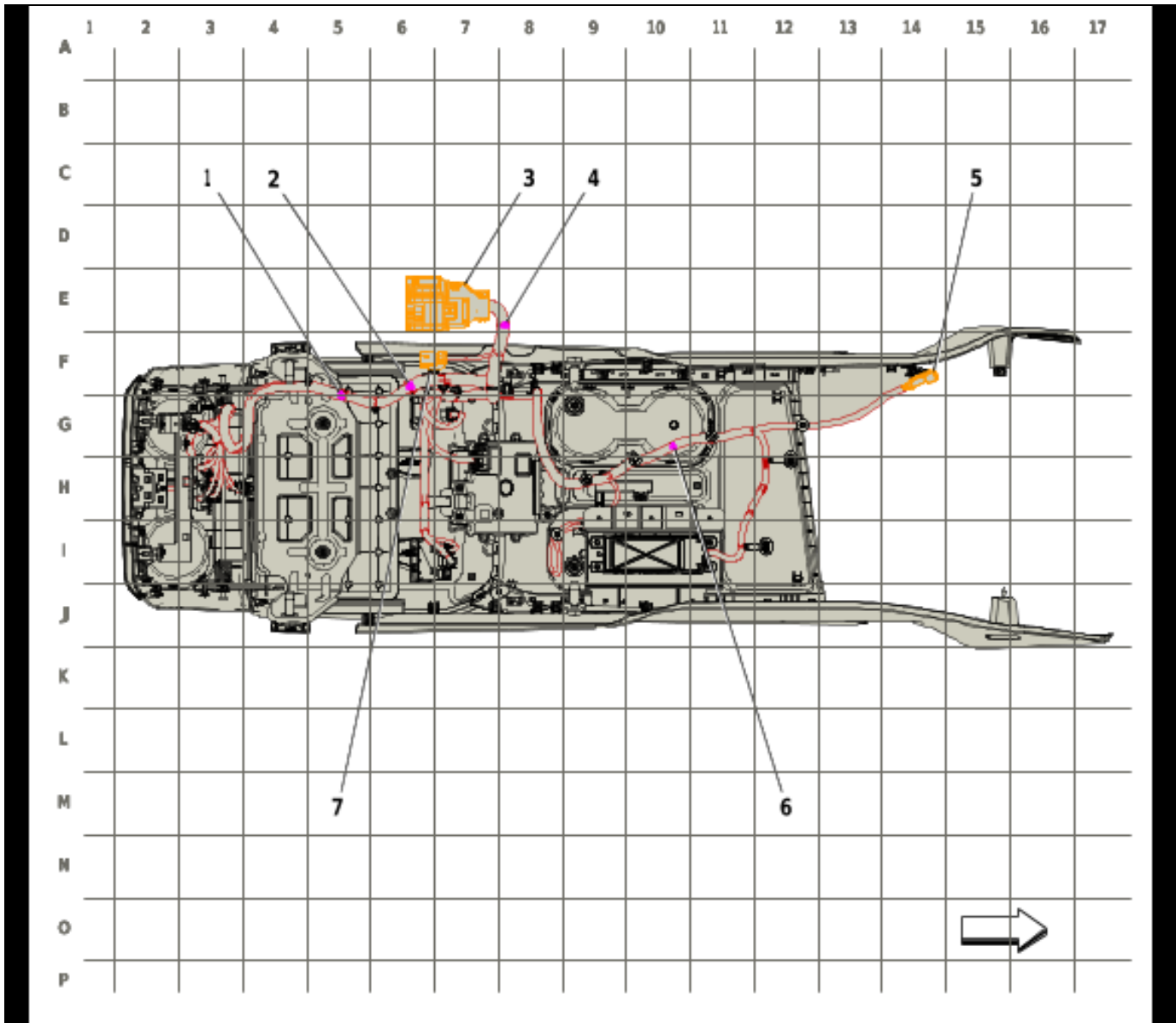

5970781

**Items**

- |     |  |     |  |
|-----|--|-----|--|
| (1) | J341 Front Floor Console Wiring Harness                        | (5) | X226 Front Floor Console Wiring Harness to Instrument Panel Wiring Harness (D07) |
| (2) | J342 Front Floor Console Wiring Harness                        | (6) | J344 Front Floor Console Wiring Harness  |
| (3) | X227 Front Floor Console Wiring Harness to Body Wiring Harness | (7) | X225 Front Floor Console Wiring Harness to Body Wiring Harness (D07)             |
| (4) | J340 Front Floor Console Wiring Harness                        |     |  |

Harness Routing Views (Passenger Compartment - Rear Seat Heater Control Wiring Harness)

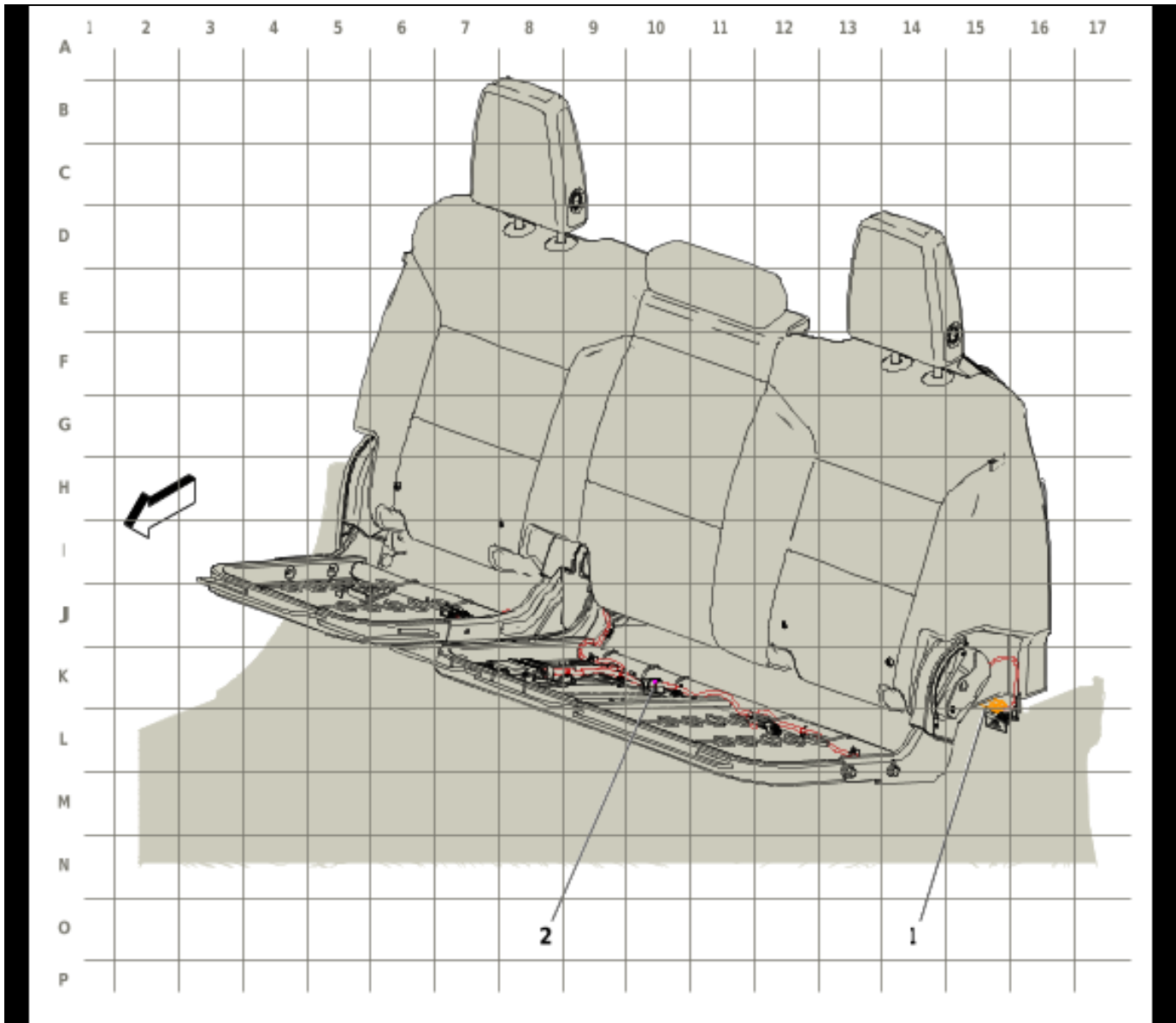

5970782

**Items**

- |     |   |     |  |
|-----|---|-----|--|
| (1) | X340 Body Wiring Harness to Rear Seat Heater Control Wiring Harness (KA6) | (2) | J350 Rear Seat Heater Control Wiring Harness - 2nd Row (KA6) |
|-----|---|-----|--|

Harness Routing Views (Roof - Dome Lamp Wiring Harness - Regular Cab)

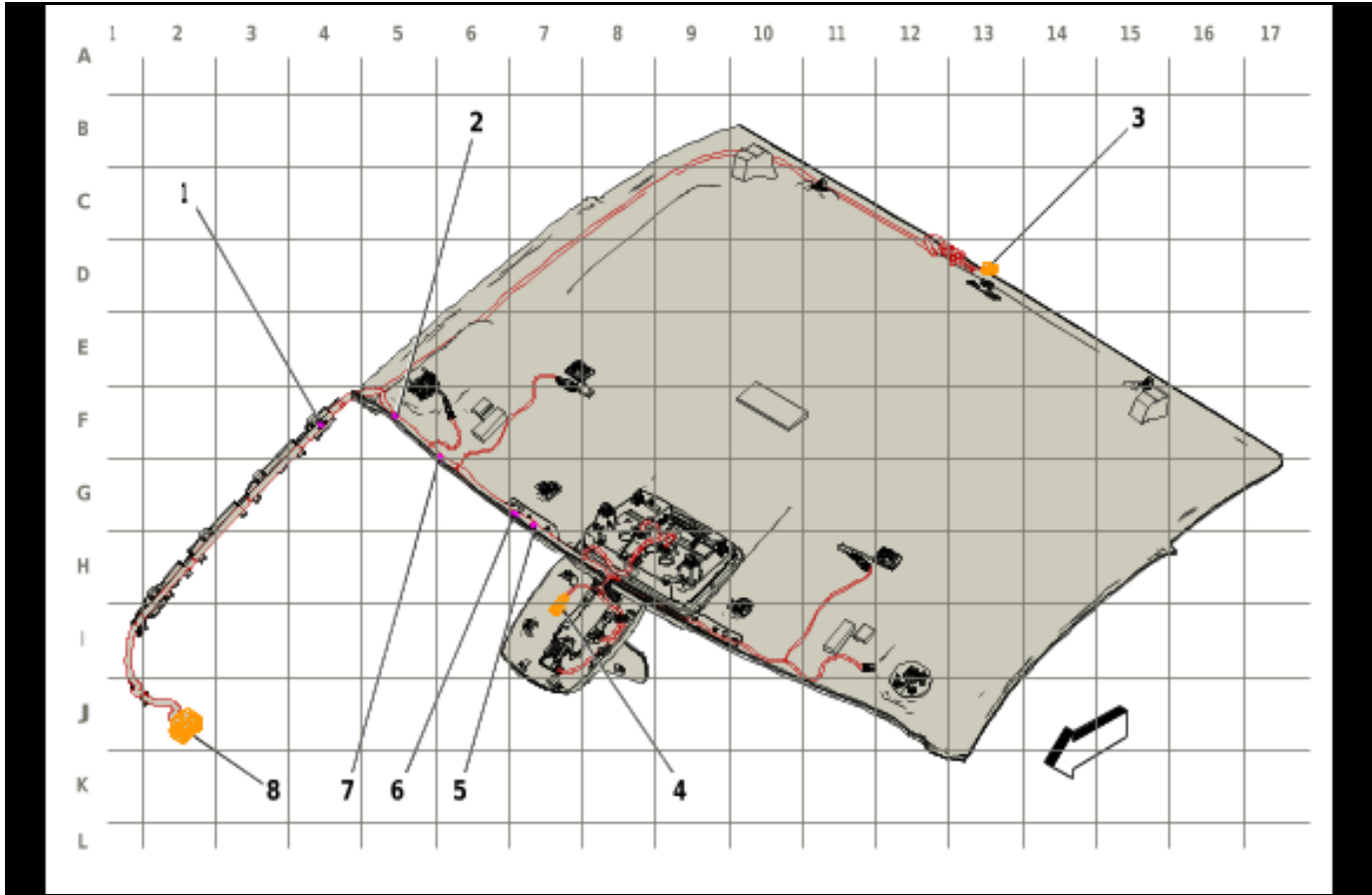

5965526

**Items**

- |     |   |     |   |
|-----|---|-----|---|
| (1) | J330 Dome Lamp Wiring Harness   | (5) | J334 Dome Lamp Wiring Harness                                       |
| (2) | J331 Dome Lamp Wiring Harness   | (6) | J333 Dome Lamp Wiring Harness                                       |
| (3) | X371 Inside Rearview Mirror Wiring Harness<br>- Jumper to Dome Lamp Wiring Harness                          | (7) | J332 Dome Lamp Wiring Harness                                       |
| (4) | X382 Headlamp Automatic Control Ambient<br>Light Sensor Wiring Harness to Dome Lamp<br>Wiring Harness (ASV) | (8) | X370 Dome Lamp Wiring Harness to<br>Instrument Panel Wiring Harness |

Harness Routing Views (Roof - Dome Lamp Wiring Harness - Double Cab)

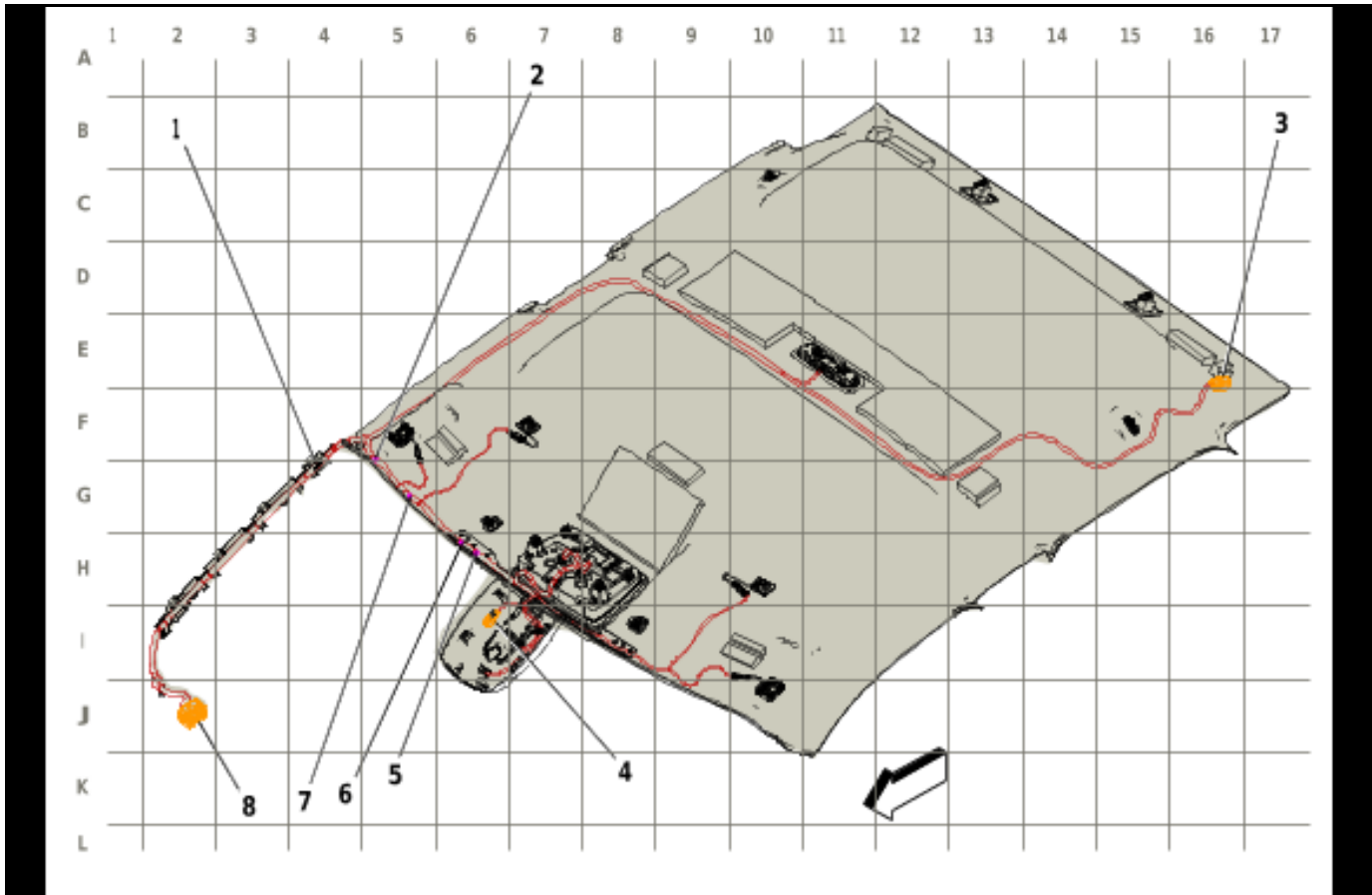

5965527

**Items**

- |  |   |
|--|---|
| <ul style="list-style-type: none"> <li>(1) J330 Dome Lamp Wiring Harness</li> <li>(2) J331 Dome Lamp Wiring Harness</li> <li>(3) X371 Inside Rearview Mirror Wiring Harness - Jumper to Dome Lamp Wiring Harness</li> <li>(4) X382 Headlamp Automatic Control Ambient Light Sensor Wiring Harness to Dome Lamp Wiring Harness (ASV)</li> </ul> | <ul style="list-style-type: none"> <li>(5) J334 Dome Lamp Wiring Harness</li> <li>(6) J333 Dome Lamp Wiring Harness</li> <li>(7) J332 Dome Lamp Wiring Harness</li> <li>(8) X370 Dome Lamp Wiring Harness to Instrument Panel Wiring Harness</li> </ul> |
|--|---|



Harness Routing Views (Roof - Dome Lamp Wiring Harness - Crew Cab)

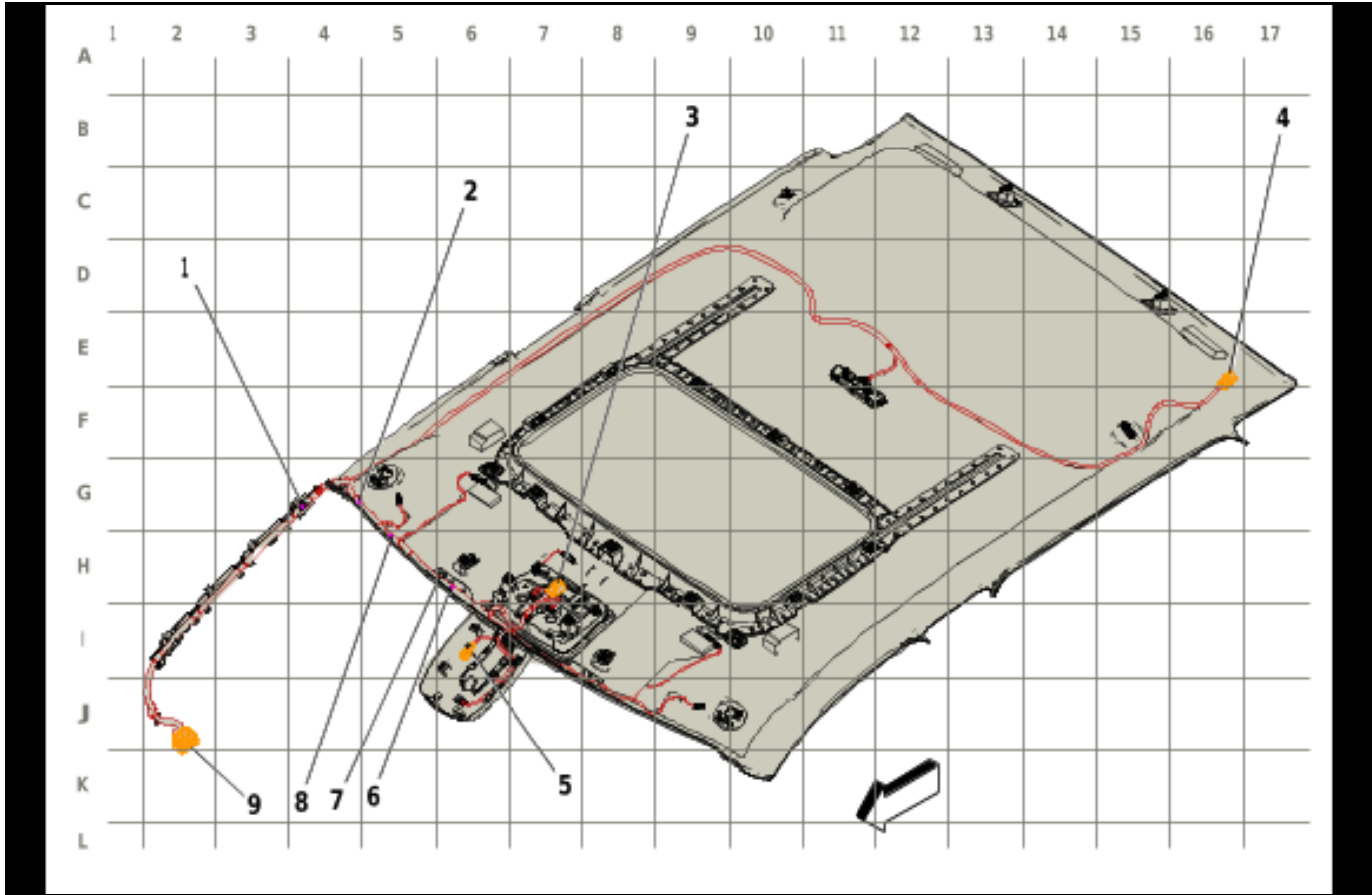

5965528

**Items**

- |   |   |
|---|---|
| <ul style="list-style-type: none"> <li>(1) J330 Dome Lamp Wiring Harness</li> <li>(2) J331 Dome Lamp Wiring Harness</li> <li>(3) X375 Sunroof Wiring Harness to Dome Lamp Wiring Harness (CF5)</li> <li>(4) X371 Inside Rearview Mirror Wiring Harness - Jumper to Dome Lamp Wiring Harness</li> <li>(5) X382 Headlamp Automatic Control Ambient Light Sensor Wiring Harness to Dome Lamp Wiring Harness (ASV)</li> </ul> | <ul style="list-style-type: none"> <li>(6) J334 Dome Lamp Wiring Harness</li> <li>(7) J333 Dome Lamp Wiring Harness</li> <li>(8) J332 Dome Lamp Wiring Harness</li> <li>(9) X370 Dome Lamp Wiring Harness to Instrument Panel Wiring Harness</li> </ul> |
|---|---|



Harness Routing Views (Roof - Rearview Driver Information Camera Rear Closure Coaxial Cable (DRZ))

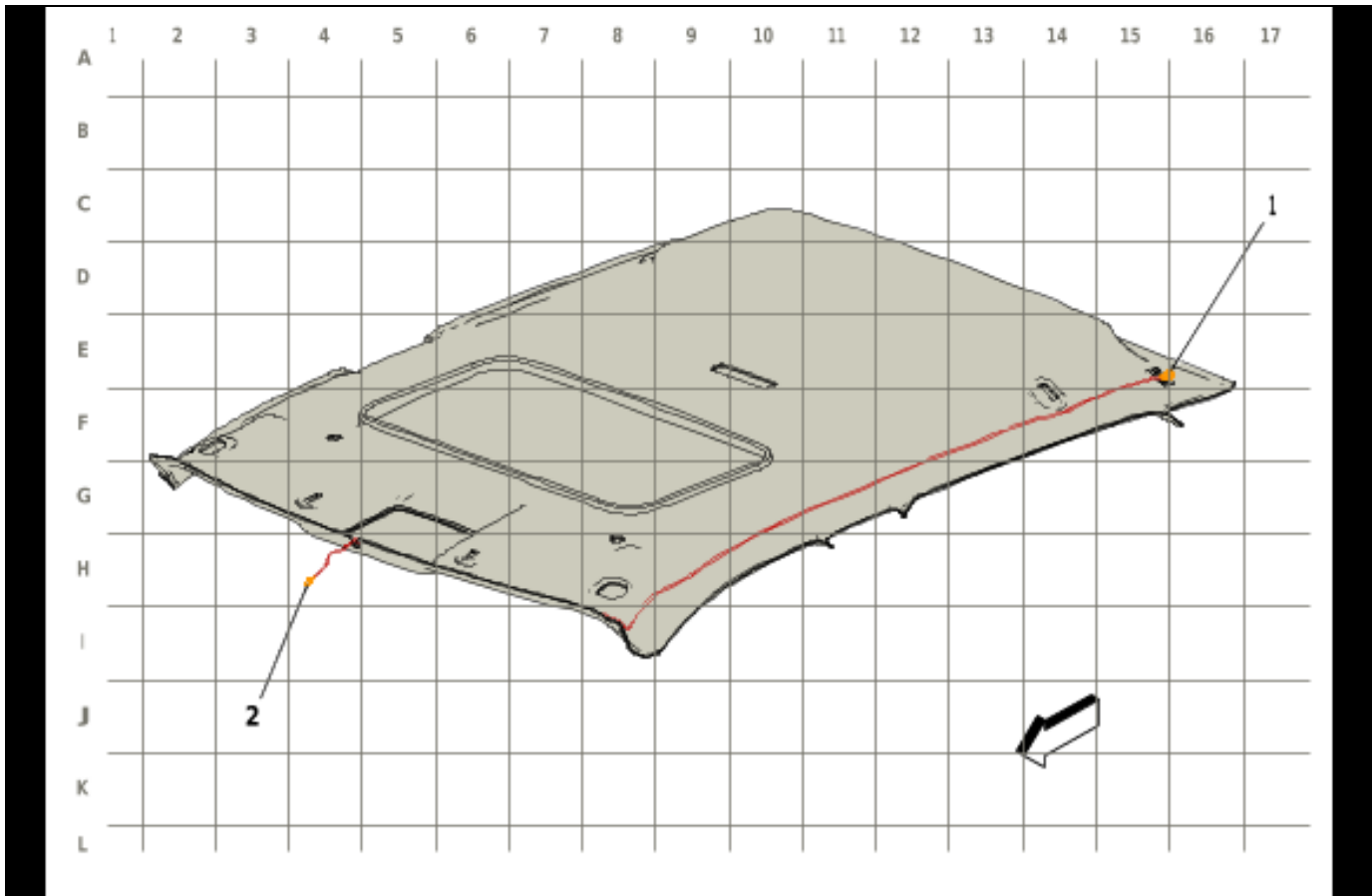

6050079

**Items**

- |   |  |
|---|--|
| <p>(1) X985 Rearview Driver Information Camera<br/>Rear Closure Coaxial Cable to Inside<br/>Rearview Mirror Wiring Harness -<br/>Jumper (DRZ)</p> | <p>(2) X381 Rearview Driver Information Camera<br/>Rear Closure Coaxial Cable to Inside<br/>Rearview Mirror Driver Information Coaxial<br/>Cable (DRZ)</p> |
|---|--|

Harness Routing Views (Doors - Front Side Door Door Wiring Harnesses - Regular Cab)

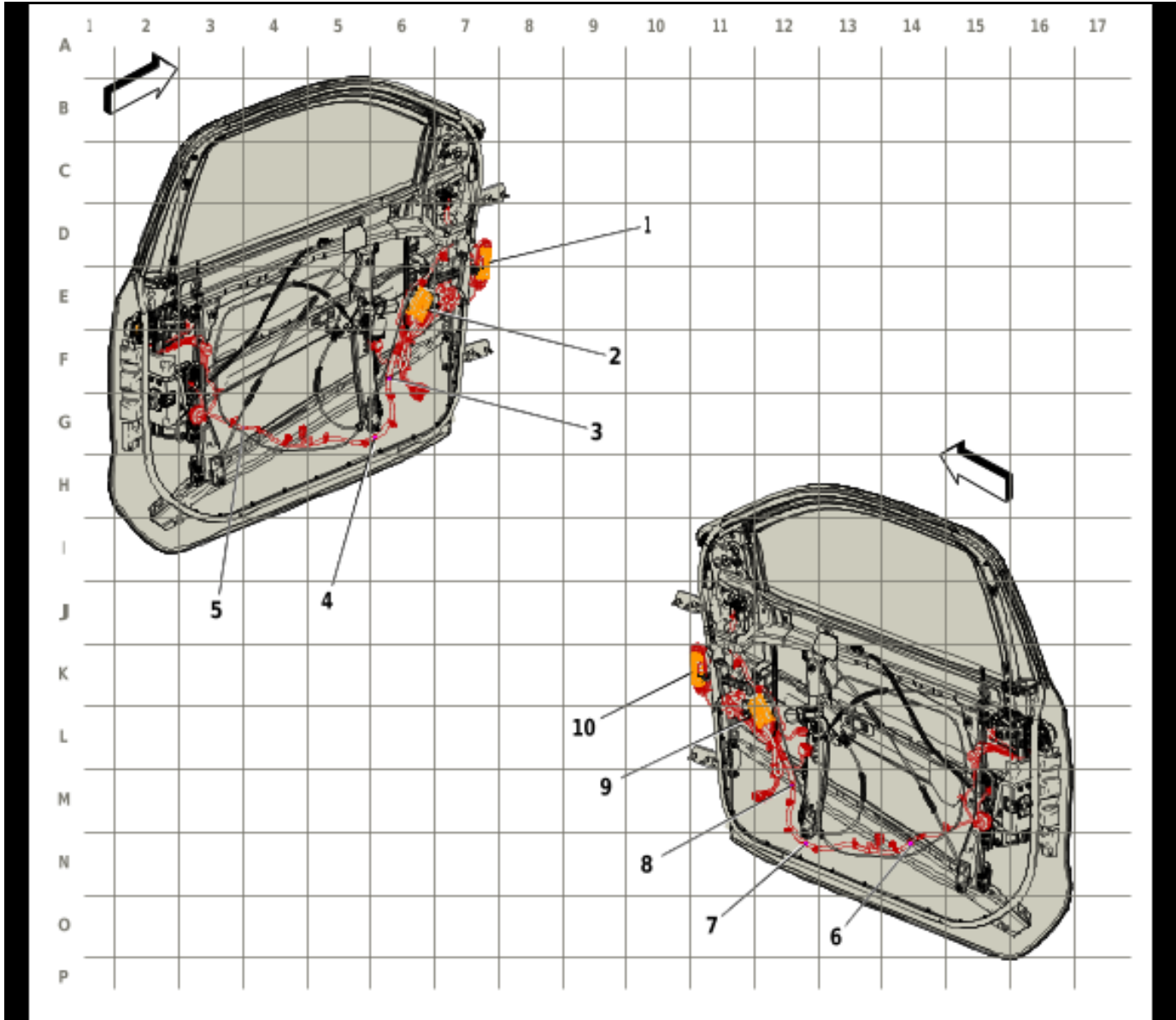

5965530

**Items**

- |  |   |
|--|---|
| <ul style="list-style-type: none"> <li>(1) X500 Front Side Door Door Wiring Harness - Driver to Body Wiring Harness</li> <li>(2) X505 Front Side Door Door Wiring Harness - Driver to Front Side Door Door Lock Door Wiring Harness - Driver</li> <li>(3) J500 Front Side Door Door Wiring Harness - Driver</li> <li>(4) J501 Front Side Door Door Wiring Harness - Driver</li> <li>(5) J502 Front Side Door Door Wiring Harness - Driver</li> </ul> | <ul style="list-style-type: none"> <li>(6) J602 Front Side Door Door Wiring Harness - Passenger</li> <li>(7) J600 Front Side Door Door Wiring Harness - Passenger</li> <li>(8) J601 Front Side Door Door Wiring Harness - Passenger</li> <li>(9) X605 Front Side Door Door Wiring Harness - Passenger to Front Side Door Door Lock Door Wiring Harness - Passenger</li> <li>(10) X600 Front Side Door Door Wiring Harness - Passenger to Body Wiring Harness</li> </ul> |
|--|---|

Harness Routing Views (Doors - Front Side Door Door Wiring Harnesses - Double Cab/ Crew Cab)

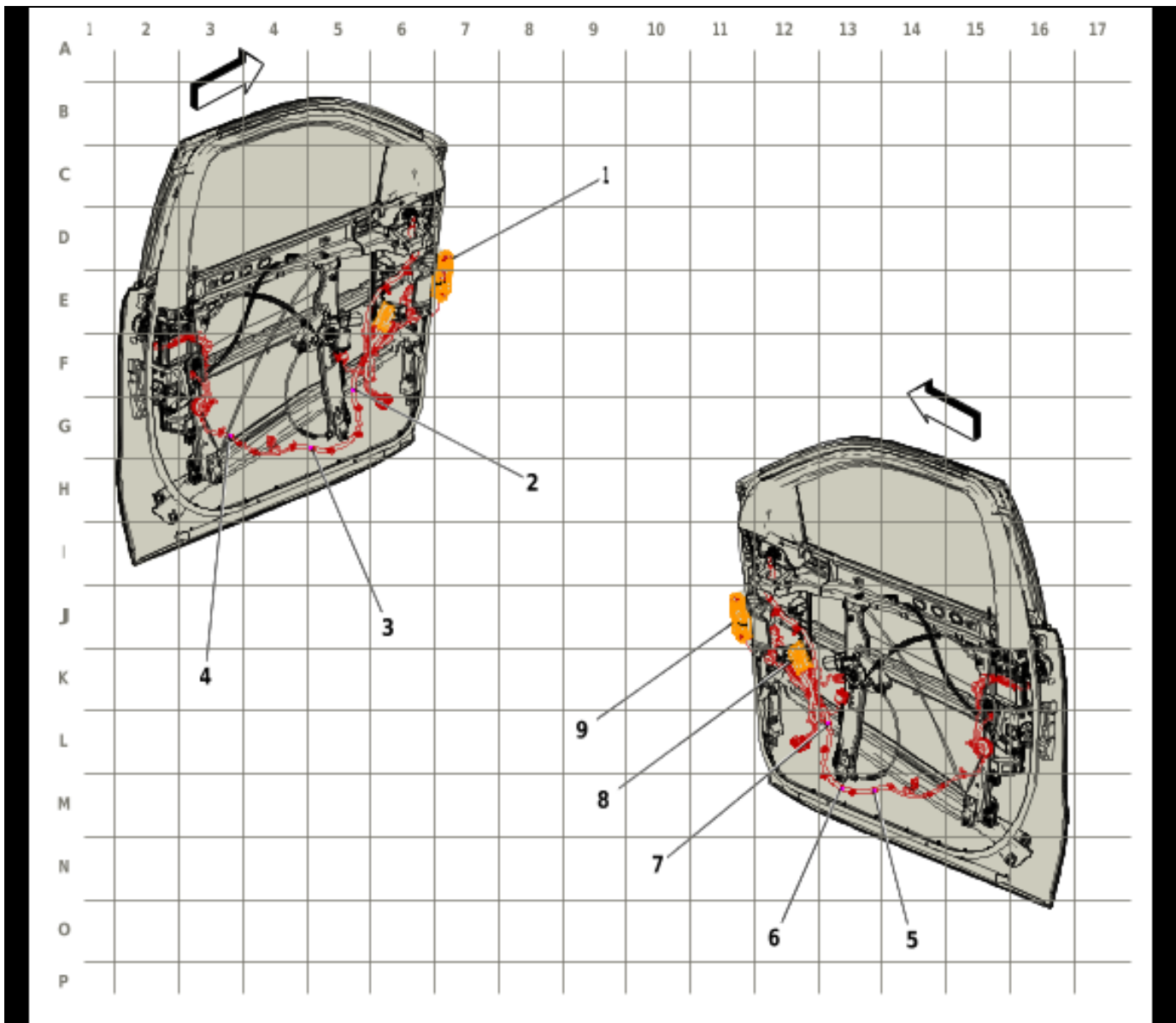

5965531

**Items**

- |   |  |
|---|--|
| <ul style="list-style-type: none"> <li>(1) X500 Front Side Door Door Wiring Harness - Driver to Body Wiring Harness</li> <li>(2) J500 Front Side Door Door Wiring Harness - Driver</li> <li>(3) J501 Front Side Door Door Wiring Harness - Driver</li> <li>(4) J502 Front Side Door Door Wiring Harness - Driver</li> <li>(5) J602 Front Side Door Door Wiring Harness - Passenger</li> </ul> | <ul style="list-style-type: none"> <li>(6) J601 Front Side Door Door Wiring Harness - Passenger</li> <li>(7) J600 Front Side Door Door Wiring Harness - Passenger</li> <li>(8) X605 Front Side Door Door Wiring Harness - Passenger to Front Side Door Door Lock Door Wiring Harness - Passenger</li> <li>(9) X600 Front Side Door Door Wiring Harness - Passenger to Body Wiring Harness</li> </ul> |
|---|--|

Harness Routing Views (Doors - Rear Side Door Door Wiring Harnesses - Double Cab)

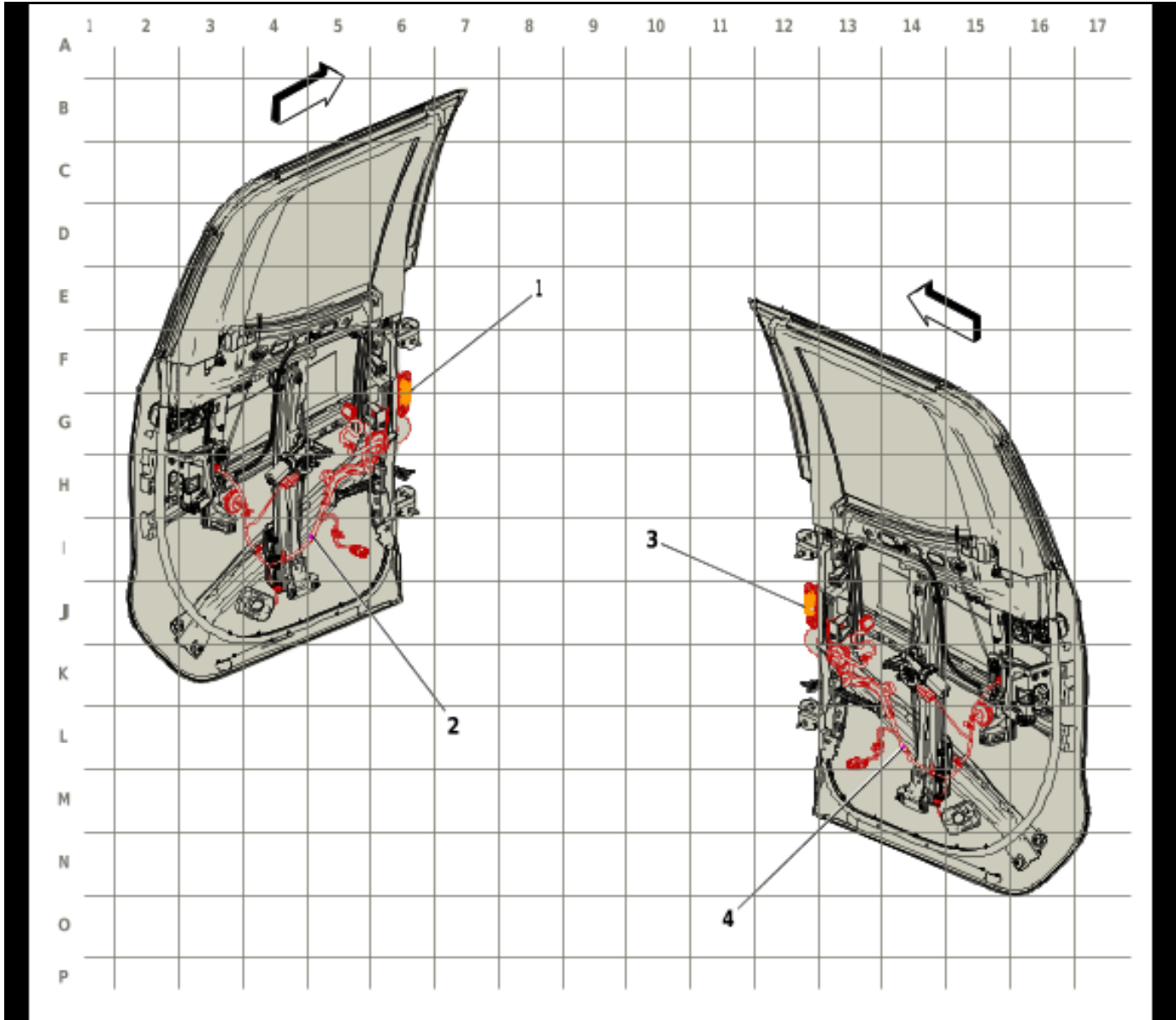

5965532

**Items**

- (1) X700 Rear Side Door Door Wiring Harness - Left to Body Wiring Harness (Double Cab/ Crew Cab)
- (2) J702 Rear Side Door Door Wiring Harness - Left

- (3) X800 Rear Side Door Door Wiring Harness - Right to Body Wiring Harness (Double Cab/ Crew Cab)
- (4) J802 Rear Side Door Door Wiring Harness - Right

Harness Routing Views (Doors - Rear Side Door Door Wiring Harnesses - Crew Cab)

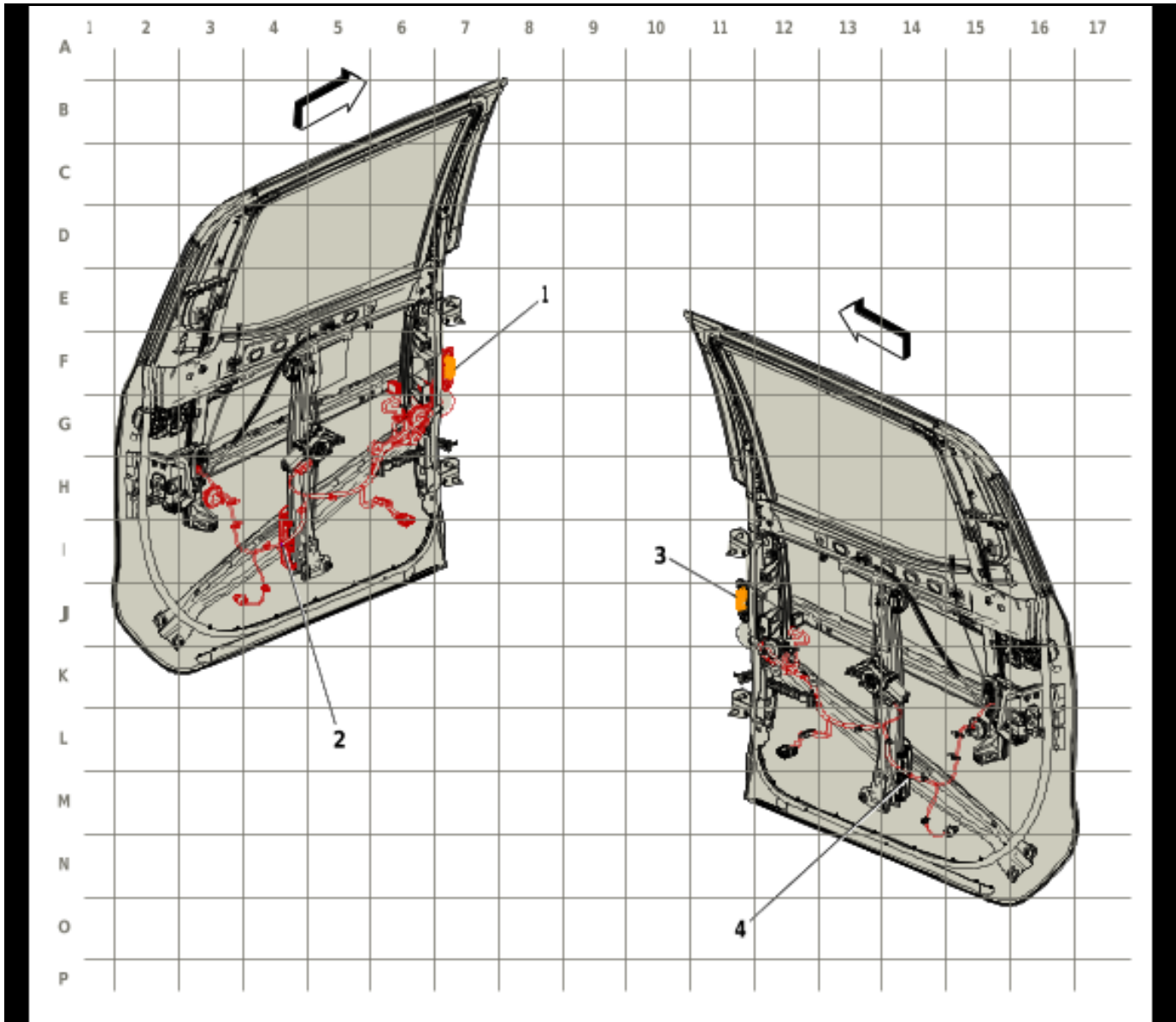

5965533

**Items**

- (1) X700 Rear Side Door Door Wiring Harness - Left to Body Wiring Harness (Double Cab/ Crew Cab)
- (2) J702 Rear Side Door Door Wiring Harness - Left

- (3) X800 Rear Side Door Door Wiring Harness - Right to Body Wiring Harness (Double Cab/ Crew Cab)
- (4) J802 Rear Side Door Door Wiring Harness - Right

Harness Routing Views (Vehicle Underbody - Chassis Wiring Harness - Regular Cab)

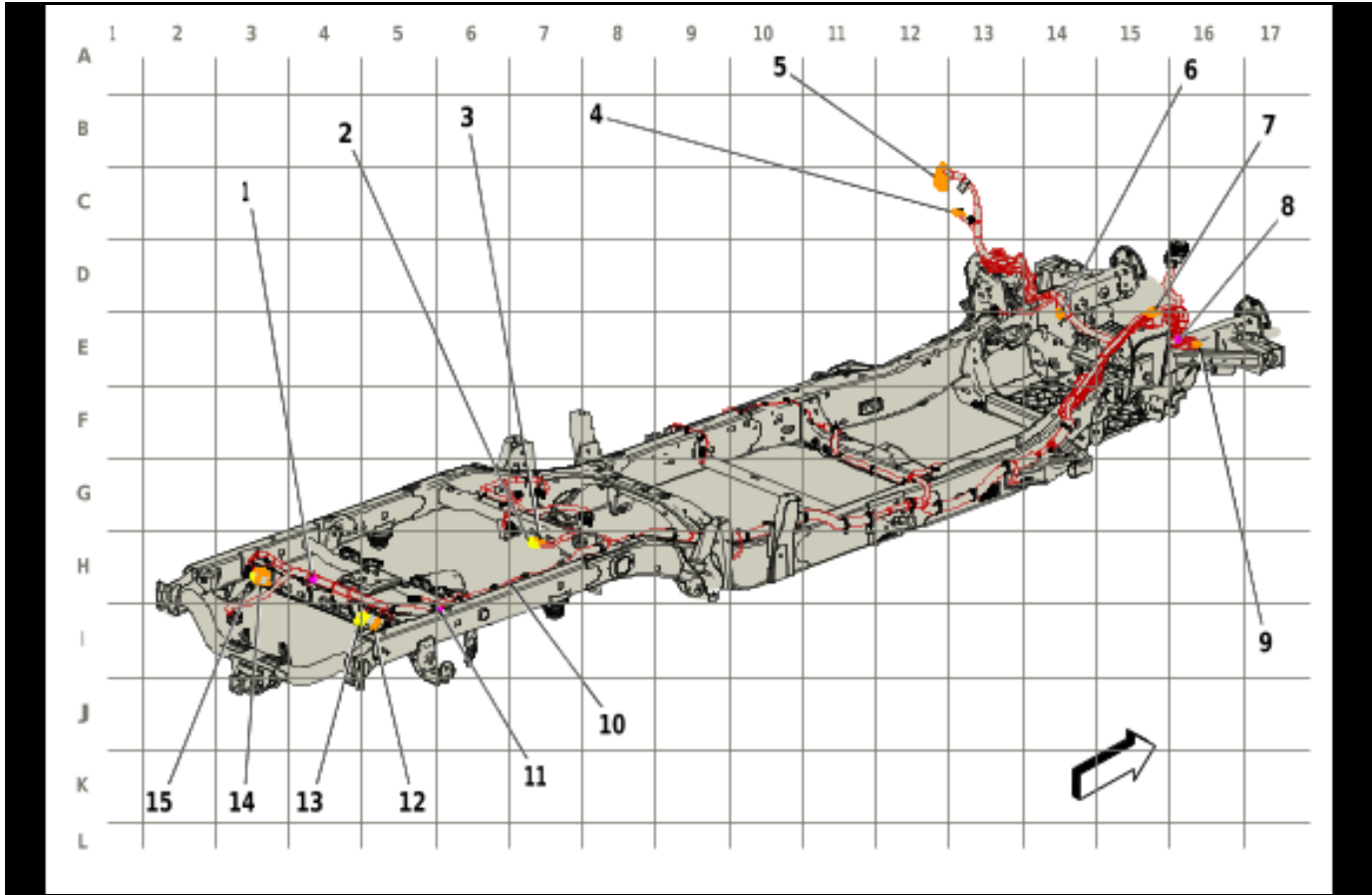

5965534

**Items**

- |  |   |
|--|---|
| (1) J402 Chassis Wiring Harness  | (8) J135 Chassis Wiring Harness (JL1/Z82-JL1)                               |
| (2) X420A Chassis Rear Wiring Harness Extension Harness to Chassis Wiring Harness  | (9) X402C Body Wiring Harness to Chassis Wiring Harness (UV2)               |
| (3) X420B Chassis Rear Wiring Harness Extension Harness to Chassis Wiring Harness  | (10) J400 Chassis Wiring Harness  |
| (4) X400 Body Wiring Harness to Chassis Wiring Harness                             | (11) J401 Chassis Wiring Harness  |
| (5) X410 Chassis Wiring Harness to Body Wiring Harness                             | (12) X414 Chassis Rear Wiring Harness to Chassis Wiring Harness (KC9/KCA)   |
| (6) X403 Chassis Wiring Harness to Power Steering Wiring Harness Extension Harness | (13) X950 Rear Object Alarm Sensor Wiring Harness to Chassis Wiring Harness |
| (7) X424 Body Wiring Harness to Chassis Wiring Harness (FHS)                       | (14) X918 Endgate Wiring Harness to Chassis Wiring Harness                  |
|  | (15) X919 Endgate Wiring Harness to Chassis Wiring Harness                  |



Harness Routing Views (Vehicle Underbody - Chassis Wiring Harness - Left - Double Cab/  
Crew Cab)

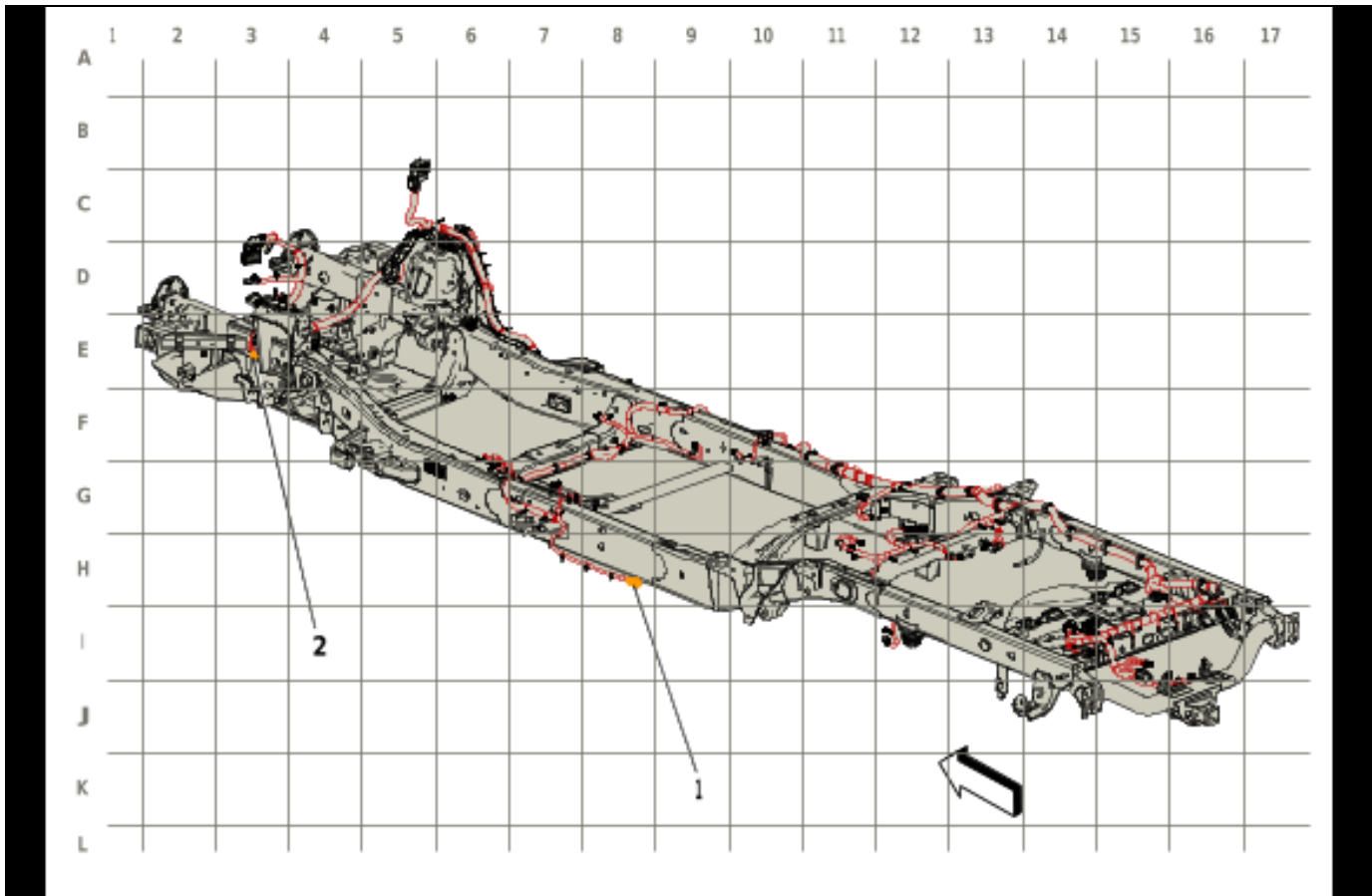

5965536

**Items**

(1) X412 Assist Step Wire Jumper - Left to Chassis Wiring Harness (BRS)

(2) X416A Chassis Wiring Harness to Electronic Suspension Strut Wiring Harness Extension Harness (Z45)

Harness Routing Views (Vehicle Underbody - Chassis Wiring Harness - Right - Double Cab/Crew Cab)

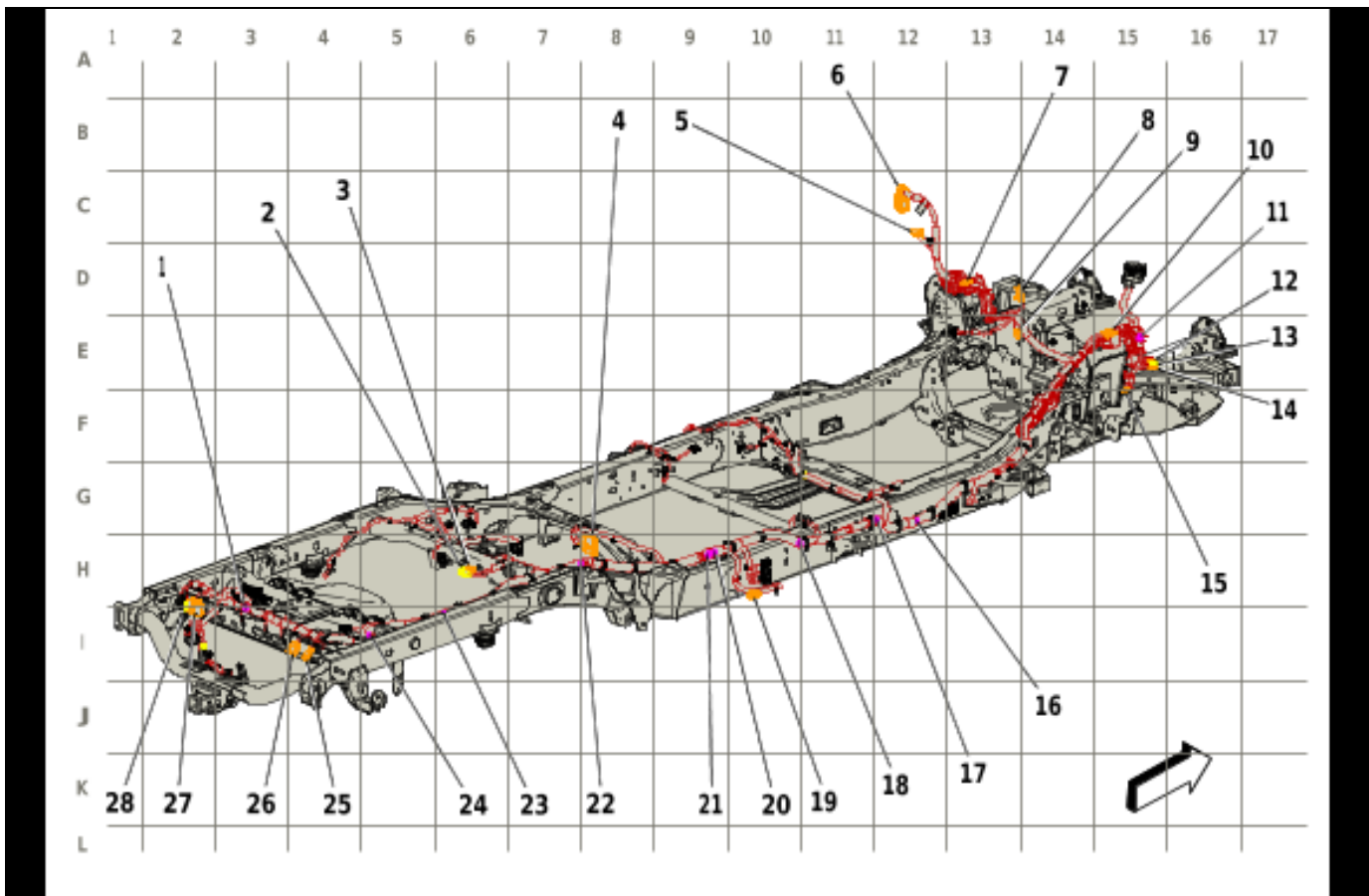

5965537

**Items**

- |  |   |
|--|---|
| (1) J402 Chassis Wiring Harness  | (13) X402C Body Wiring Harness to Chassis Wiring Harness (UV2)  |
| (2) X420A Chassis Rear Wiring Harness Extension Harness to Chassis Wiring Harness                                      | (14) X402A Body Wiring Harness to Chassis Wiring Harness (UV2)  |
| (3) X420B Chassis Rear Wiring Harness Extension Harness to Chassis Wiring Harness                                      | (15) X416B Chassis Wiring Harness to Electronic Suspension Strut Wiring Harness Extension Harness (Z45) |
| (4) X404 Emission Reduction Fluid Tank Reservoir Wire Harness to Chassis Wiring Harness (LZ0)                          | (16) J320 Chassis Wiring Harness  |
| (5) X400 Body Wiring Harness to Chassis Wiring Harness   | (17) J321 Chassis Wiring Harness  |
| (6) X410 Chassis Wiring Harness to Body Wiring Harness   | (18) J322 Chassis Wiring Harness  |
| (7) X416C Transfer Case Selector Shift Control Switch Wiring Harness Extension Harness to Chassis Wiring Harness (G93) | (19) X413 Assist Step Wire Jumper - Right to Chassis Wiring Harness (BRS)                               |
| (8) X401 Engine Wiring Harness to Chassis Wiring Harness (LZ0)   | (20) J323 Chassis Wiring Harness  |
| (9) X403 Chassis Wiring Harness to Power Steering Wiring Harness Extension Harness                                     | (21) J324 Chassis Wiring Harness  |
| (10) X424 Body Wiring Harness to Chassis Wiring Harness (FHS)  | (22) J326 Chassis Wiring Harness  |
| (11) J135 Chassis Wiring Harness (JL1/Z82-JL1)   | (23) J400 Chassis Wiring Harness  |
| (12) X402B Body Wiring Harness to Chassis Wiring Harness (UV2)   | (24) J401 Chassis Wiring Harness  |
|  | (25) X414 Chassis Rear Wiring Harness to Chassis Wiring Harness (KC9/KCA)                               |
|  | (26) X950 Rear Object Alarm Sensor Wiring Harness to Chassis Wiring Harness                             |
|  | (27) X918 Endgate Wiring Harness to Chassis Wiring Harness  |



- (28) X919 Endgate Wiring Harness to Chassis Wiring Harness

**Harness Routing Views (Vehicle Underbody - Chassis Rear Wiring Harness Extension Harness)**

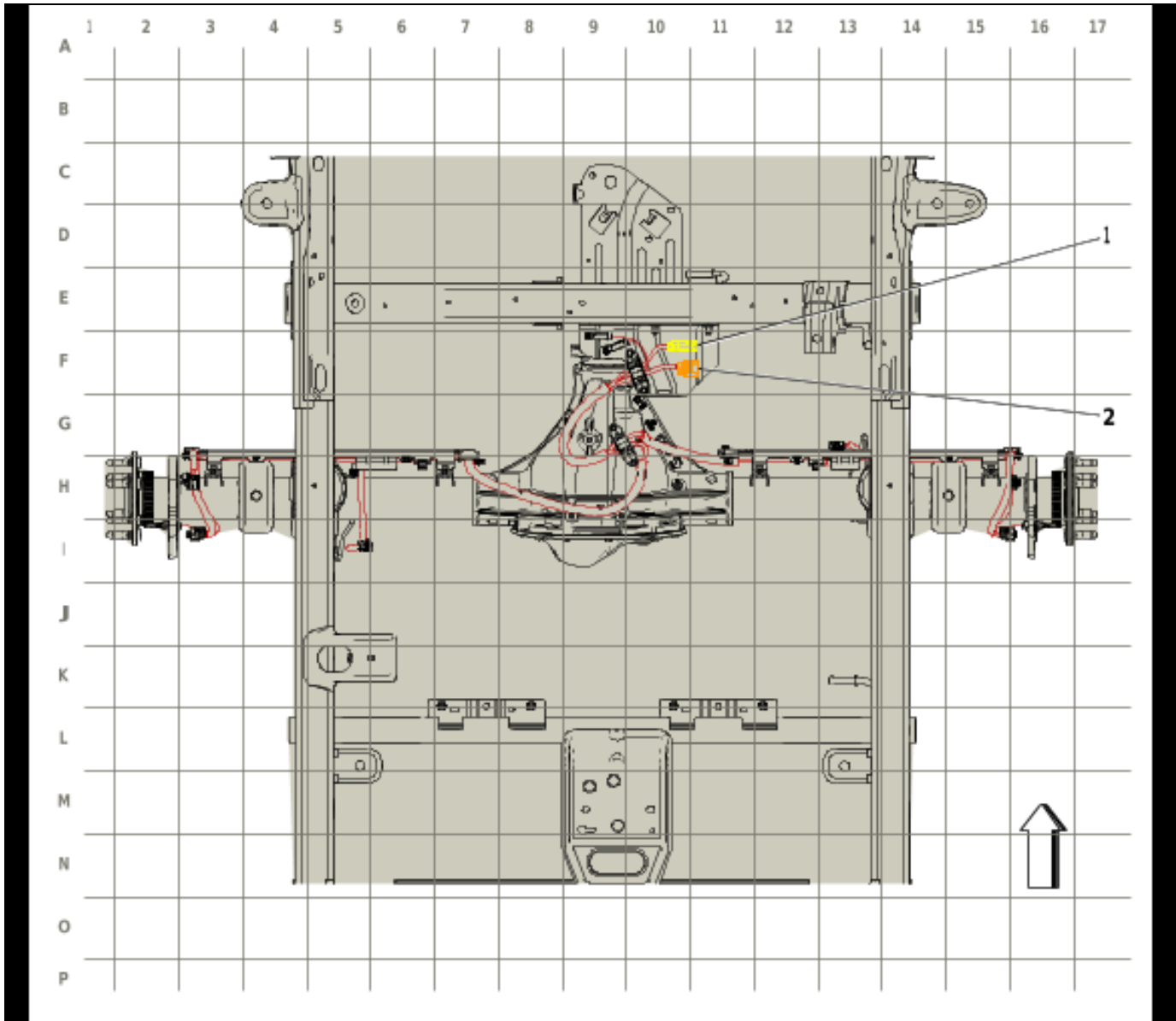

5965538

**Items**

- |  |  |
|--|--|
| <p>(1) X420B Chassis Rear Wiring Harness Extension Harness to Chassis Wiring Harness</p> | <p>(2) X420A Chassis Rear Wiring Harness Extension Harness to Chassis Wiring Harness</p> |
|--|--|

Harness Routing Views (Rear of Pickup Box - Chassis Rear Wiring Harness)

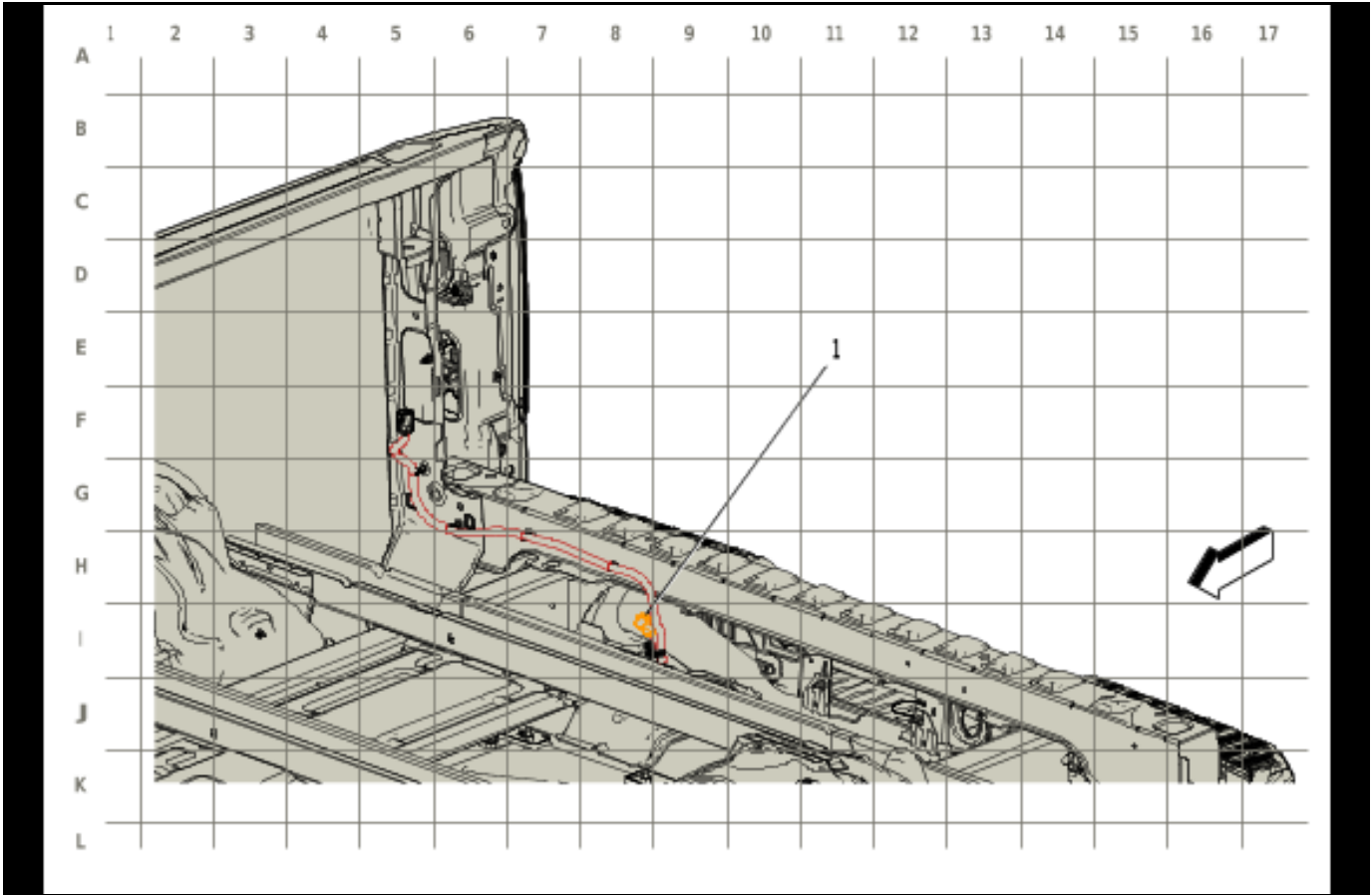

5965539

**Items**

- (1) X414 Chassis Rear Wiring Harness to Chassis Wiring Harness (KC9/KCA)

Harness Routing Views (Rear of Vehicle - Endgate Wiring Harness (QK1))

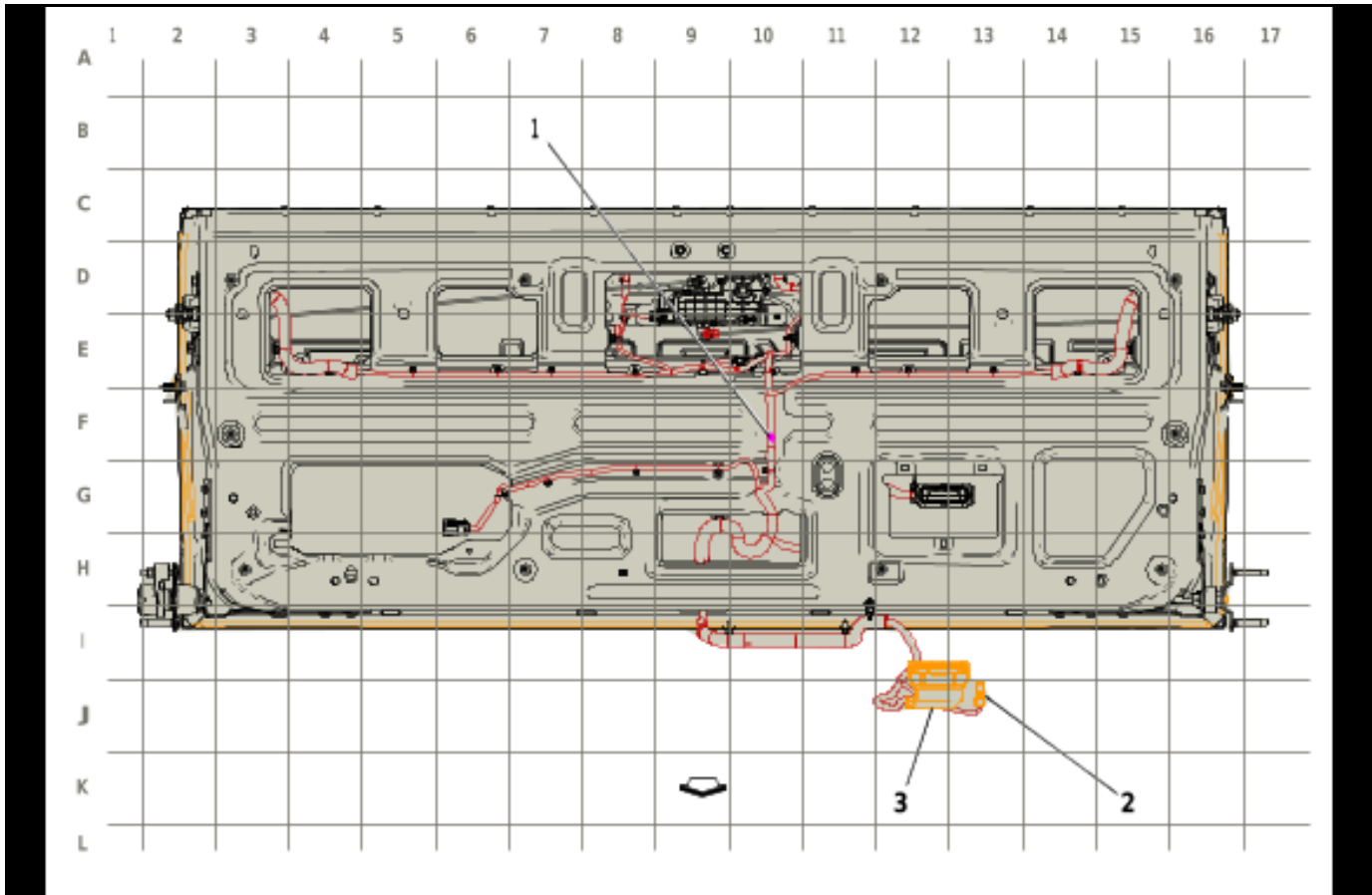

5965541

**Items**

- |  |   |
|--|---|
| <ul style="list-style-type: none"> <li>(1) J913 Endgate Wiring Harness</li> <li>(2) X919 Endgate Wiring Harness to Chassis Wiring Harness</li> </ul> | <ul style="list-style-type: none"> <li>(3) X918 Endgate Wiring Harness to Chassis Wiring Harness</li> </ul> |
|--|---|

Harness Routing Views (Rear of Vehicle - Endgate Wiring Harness (QK2))

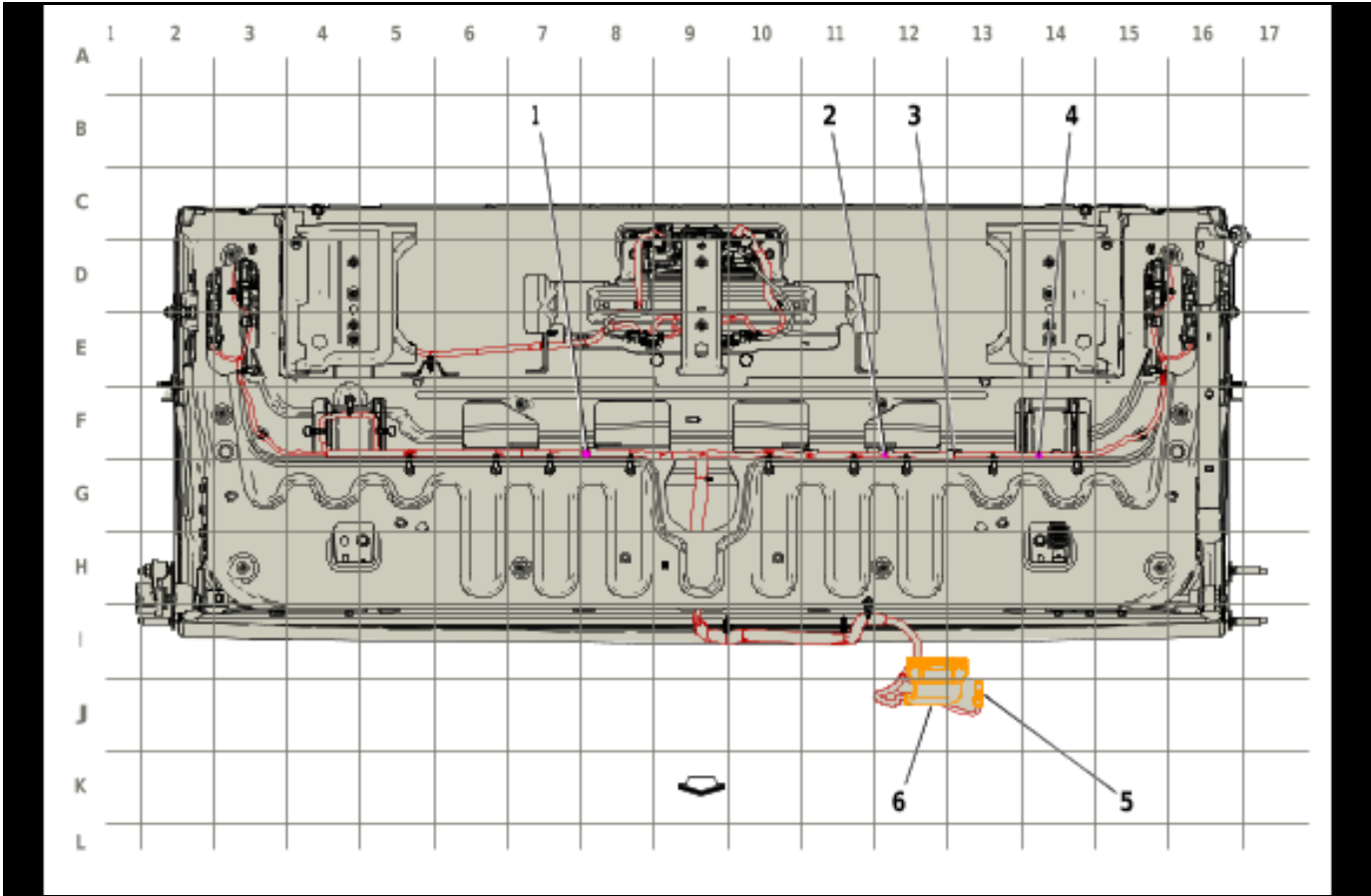

5965542

**Items**

- |   |   |
|---|---|
| (1) J913 Endgate Wiring Harness           | (5) X919 Endgate Wiring Harness to Chassis Wiring Harness |
| (2) J910 Endgate Wiring Harness (QK2+QT5) | (6) X918 Endgate Wiring Harness to Chassis Wiring Harness |
| (3) J911 Endgate Wiring Harness (QK2+QT5) |   |
| (4) J912 Endgate Wiring Harness (QK2)     |   |

Harness Routing Views (Rear of Vehicle - Rear Object Alarm Sensor Harness (UKL))

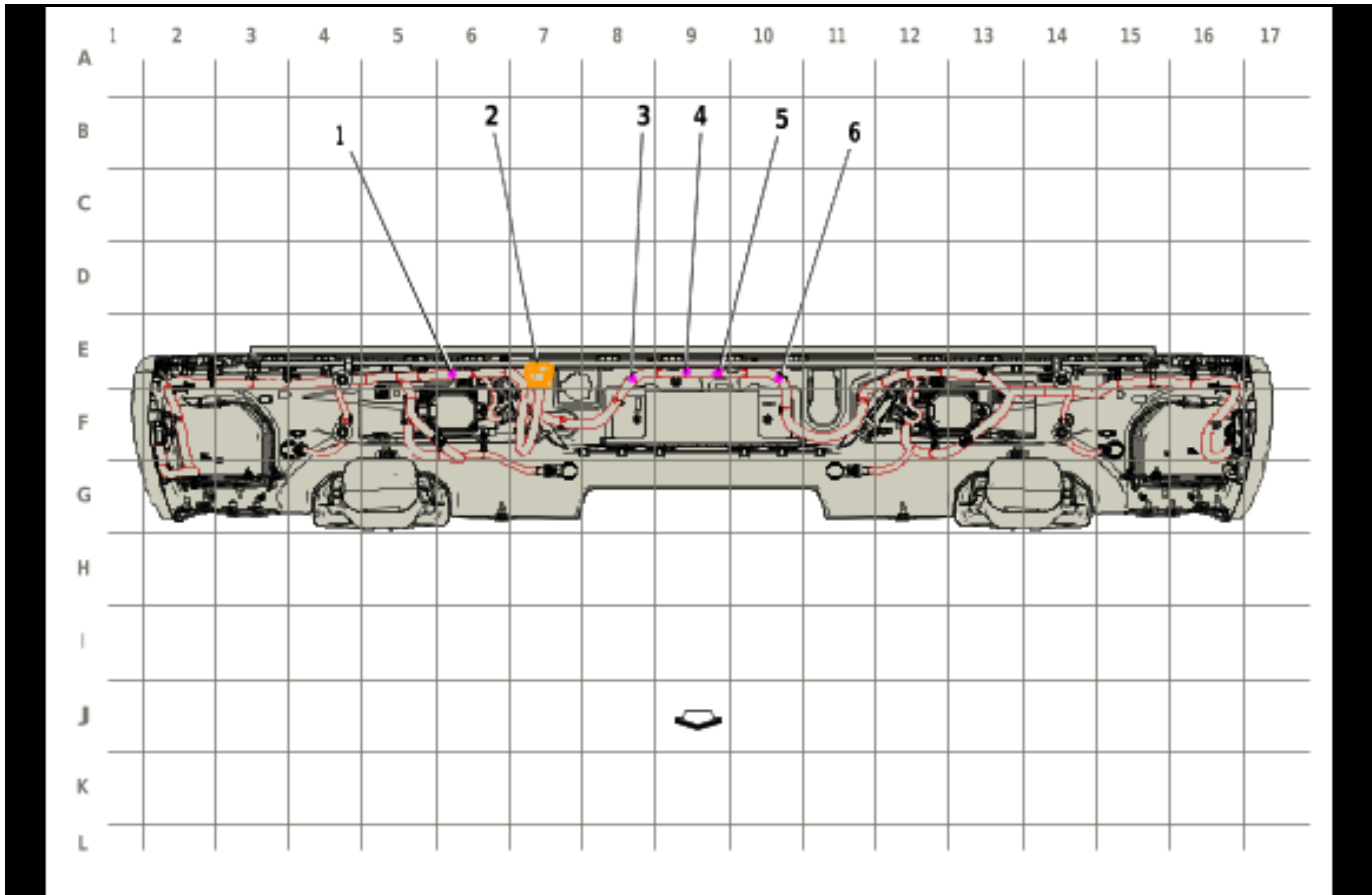

6141580

**Items**

- |  |  |
|--|--|
| <ul style="list-style-type: none"> <li>(1) J905 Rear Object Alarm Sensor Wiring Harness</li> <li>(2) X950 Rear Object Alarm Sensor Wiring Harness to Chassis Wiring Harness</li> <li>(3) J904 Rear Object Alarm Sensor Wiring Harness</li> </ul> | <ul style="list-style-type: none"> <li>(4) J903 Rear Object Alarm Sensor Wiring Harness</li> <li>(5) J902 Rear Object Alarm Sensor Wiring Harness (UKL)</li> <li>(6) J901 Rear Object Alarm Sensor Wiring Harness</li> </ul> |
|--|--|

Harness Routing Views (Rear of Vehicle - Rear Object Alarm Sensor Harness (- UKL))

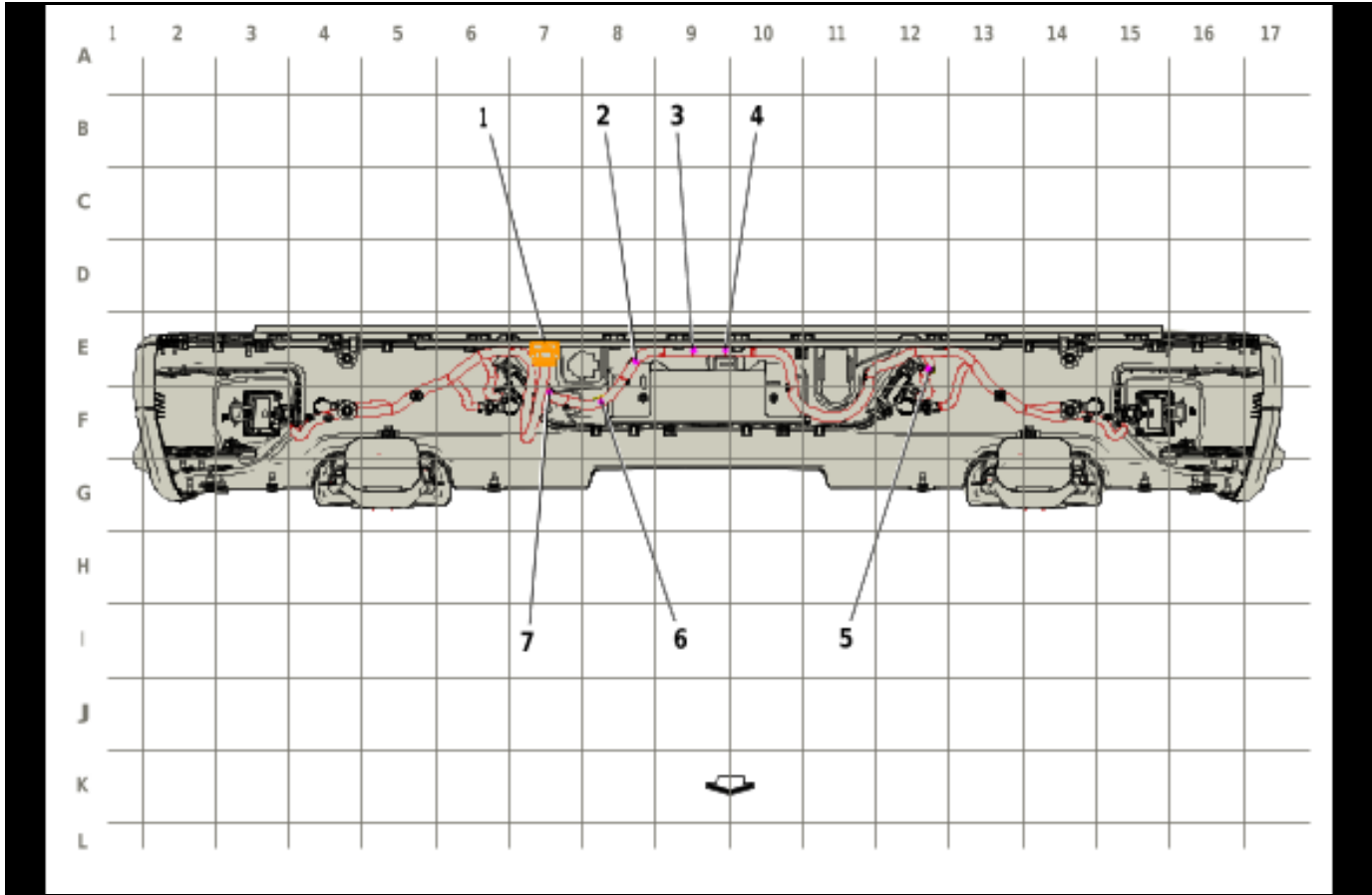

6141583

**Items**

- |  |  |
|--|--|
| <ul style="list-style-type: none"> <li>(1) X950 Rear Object Alarm Sensor Wiring Harness to Chassis Wiring Harness</li> <li>(2) J905 Rear Object Alarm Sensor Wiring Harness</li> <li>(3) J903 Rear Object Alarm Sensor Wiring Harness</li> <li>(4) J904 Rear Object Alarm Sensor Wiring Harness</li> </ul> | <ul style="list-style-type: none"> <li>(5) J900 Rear Object Alarm Sensor Wiring Harness</li> <li>(6) J901 Rear Object Alarm Sensor Wiring Harness</li> <li>(7) J906 Rear Object Alarm Sensor Wiring Harness (without UKL)</li> </ul> |
|--|--|

# Power Outlets

## Schematic and Routing Diagrams

Cigar Lighter/Power Outlet Schematics (Power and Charge Receptacles (KC5 / UBI))

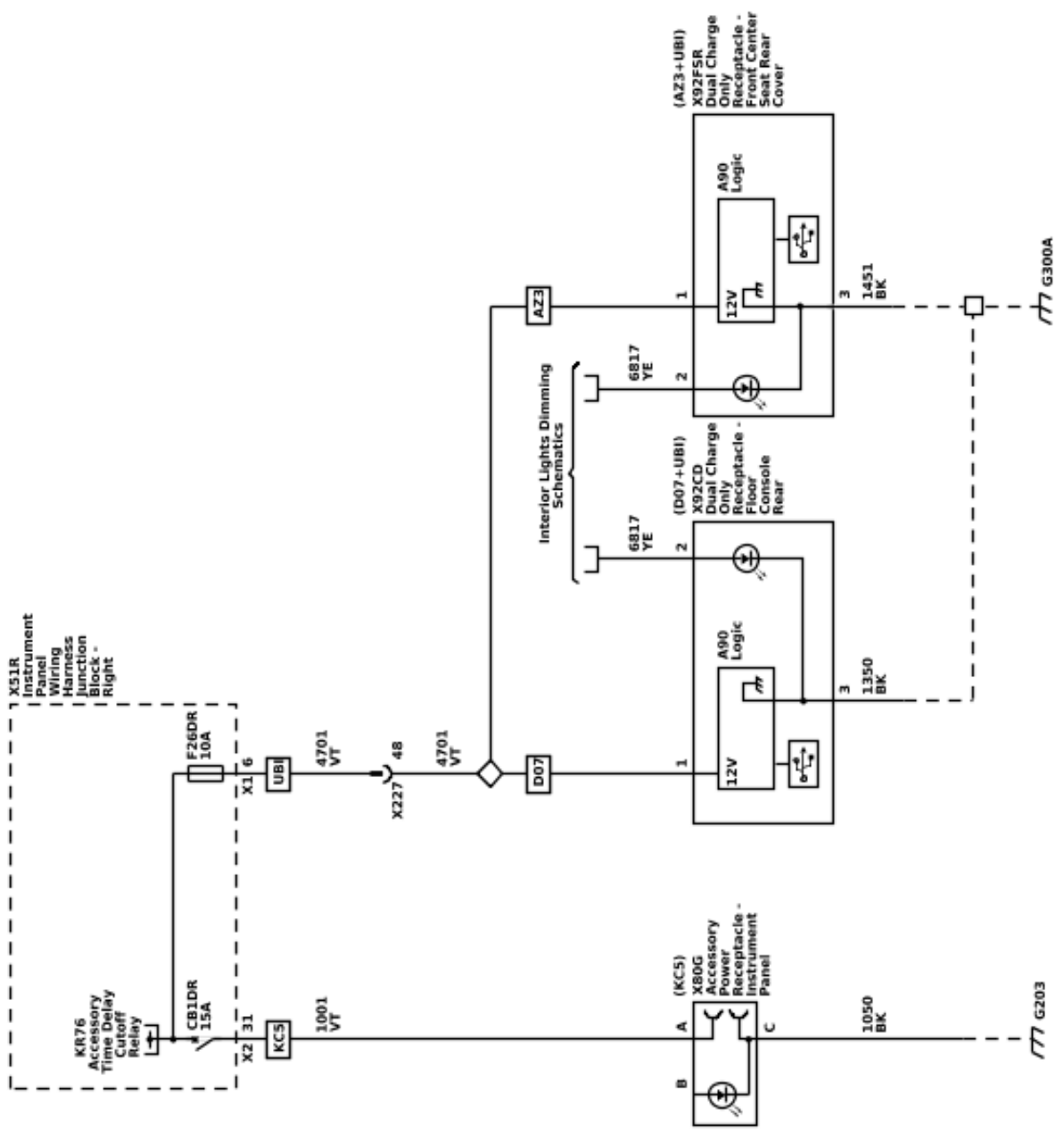
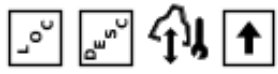



Cigar Lighter/Power Outlet Schematics (Inverter Module Power, Ground, and Serial Data (KI4 / KI5 / KCA / KC9))

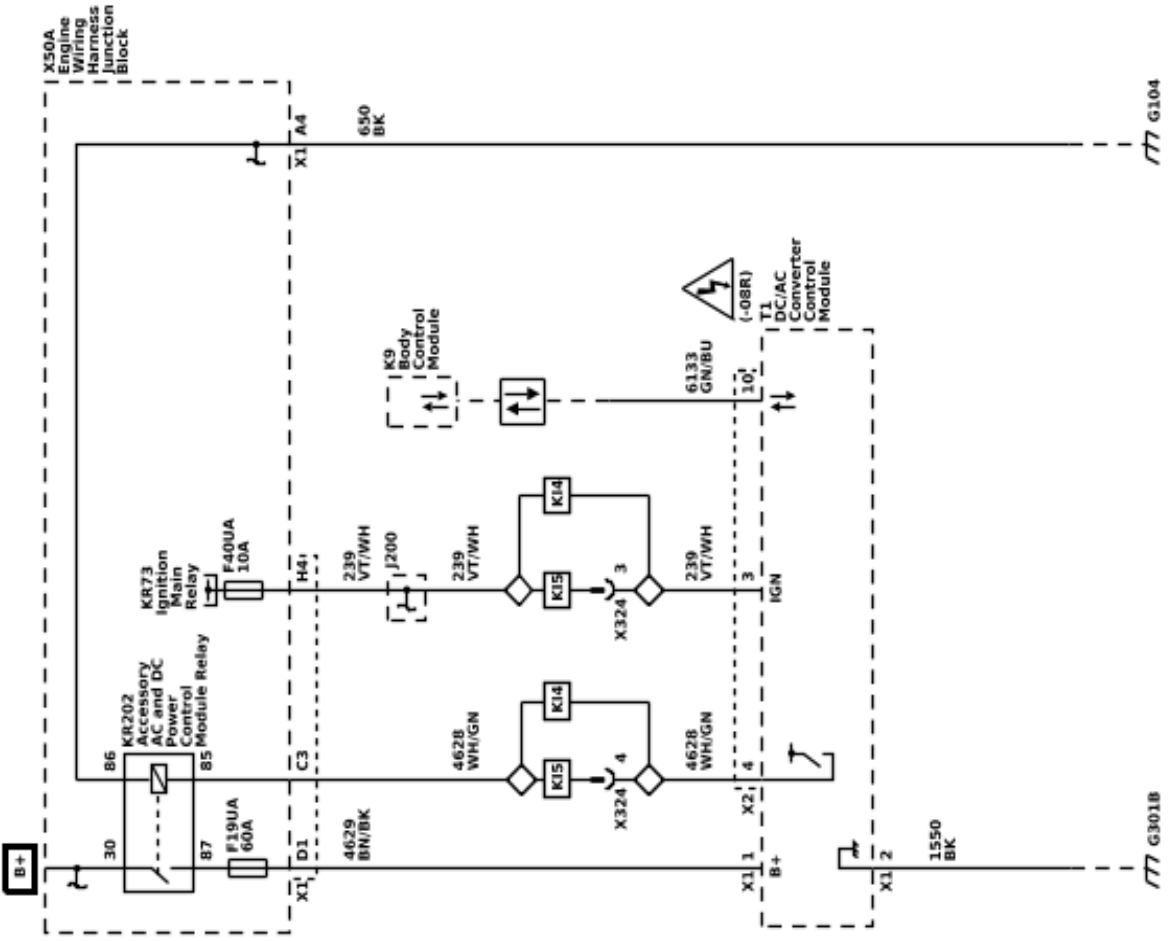

6278939

Cigar Lighter/Power Outlet Schematics (110V AC Accessory Power Rear Receptacle - Front Floor Console (K14 & D07))

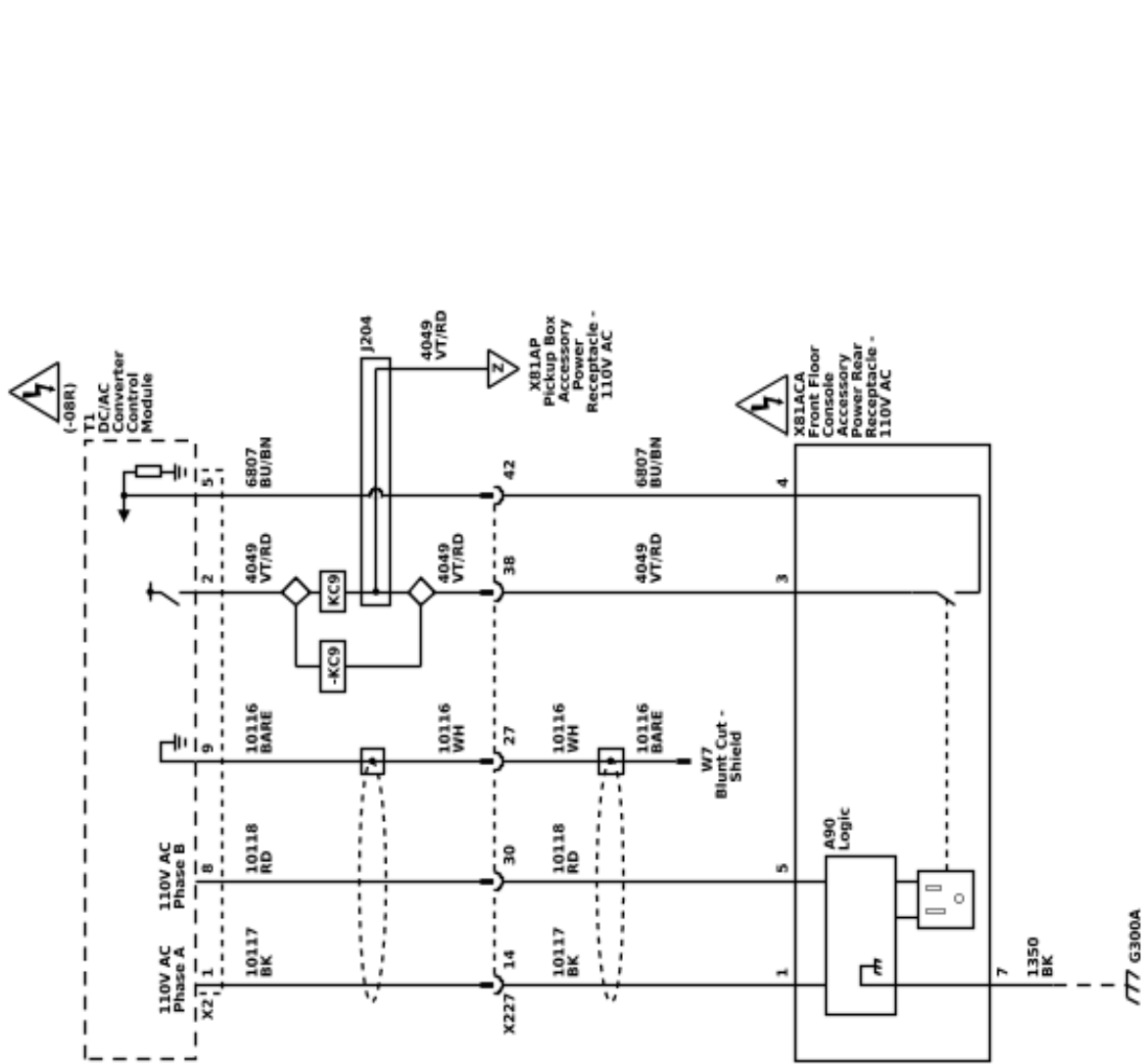

Cigar Lighter/Power Outlet Schematics (220V AC Accessory Power Rear Receptacle - Front Floor Console (K15 & D07))

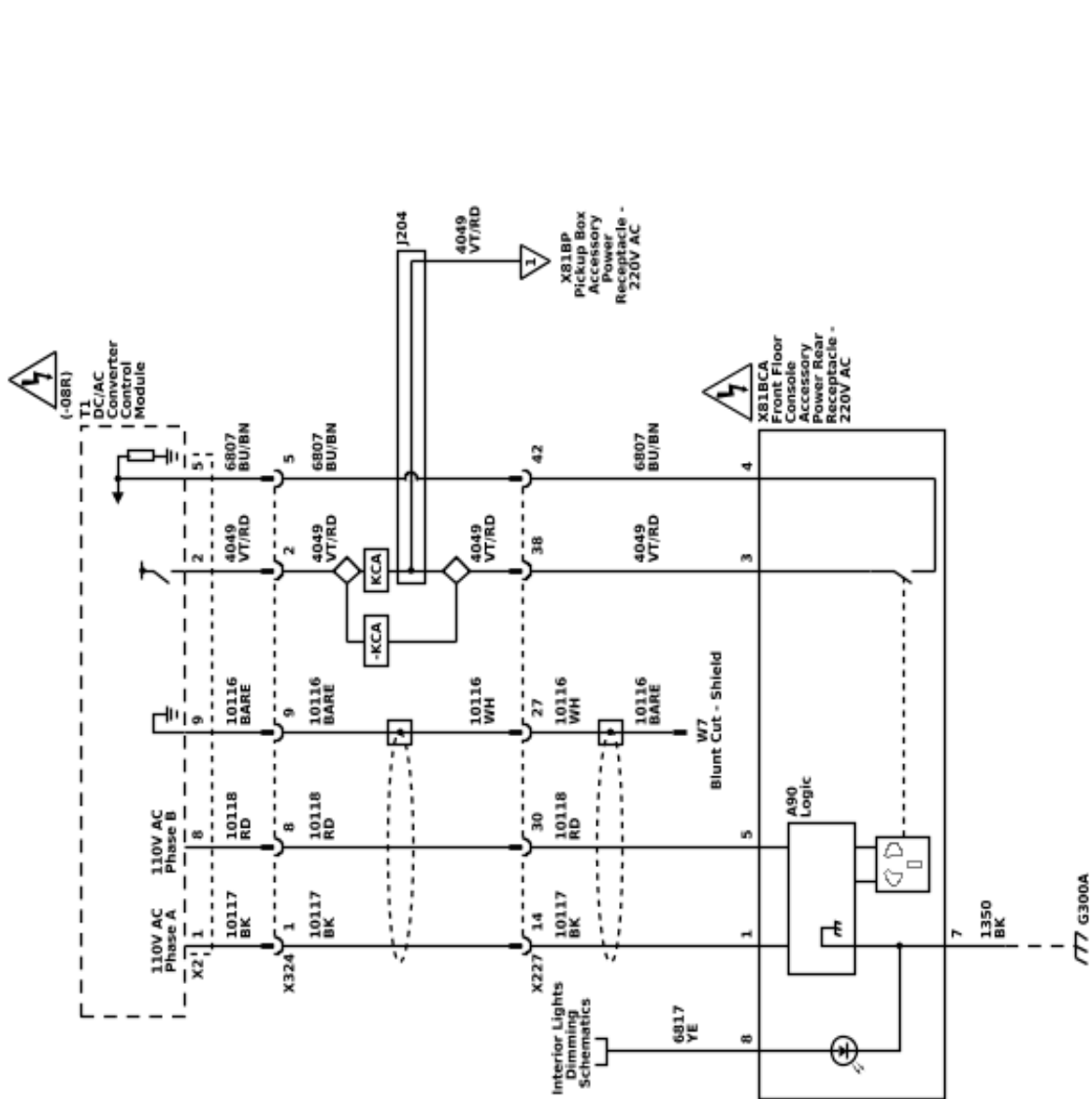

6278941

Cigar Lighter/Power Outlet Schematics (110V AC Accessory Power Receptacle - Front Center Seat Rear (K14 & AZ3))

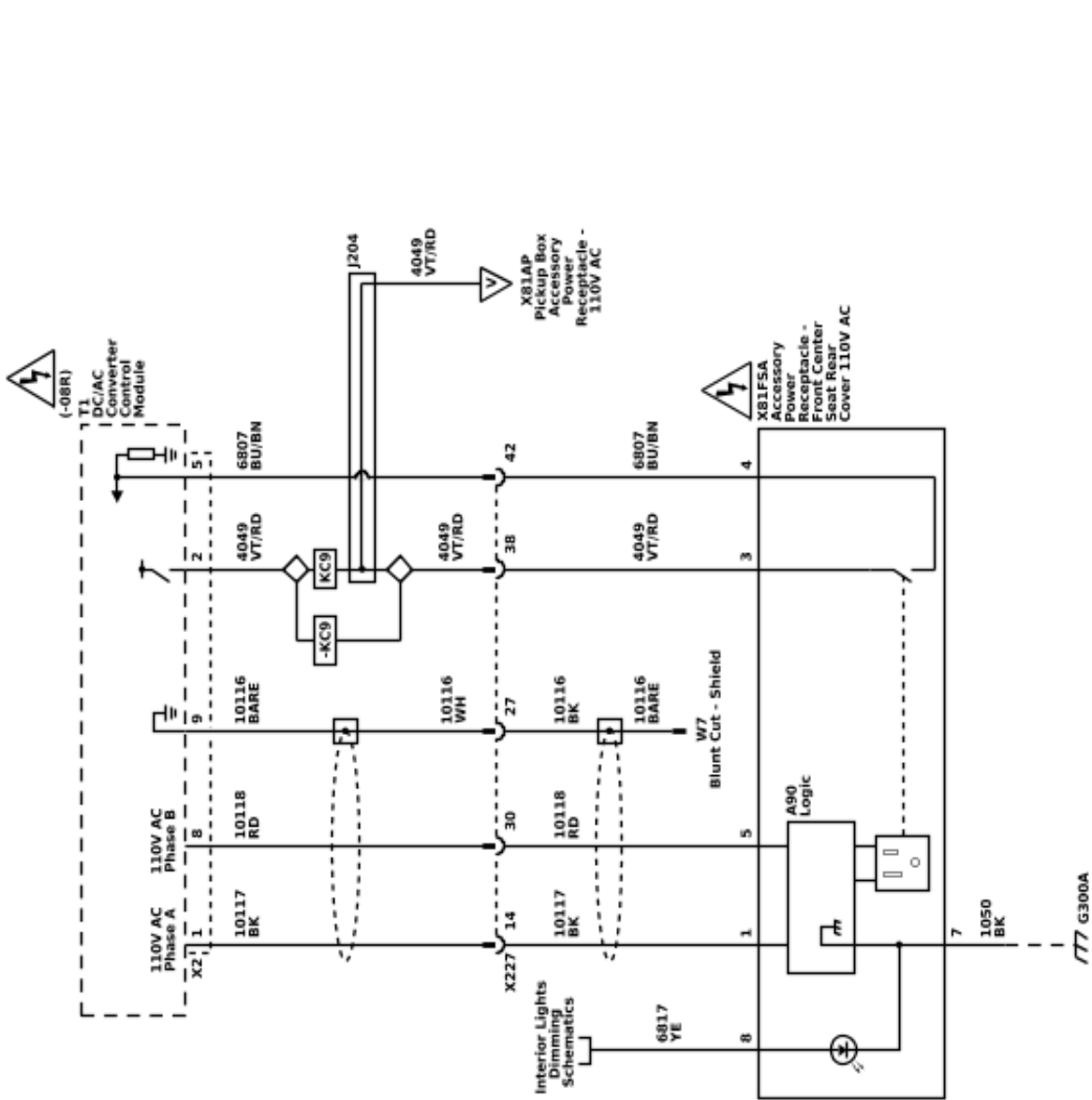

Cigar Lighter/Power Outlet Schematics (220V AC Accessory Power Receptacle - Front Center Seat Rear (K15 & AZ3))

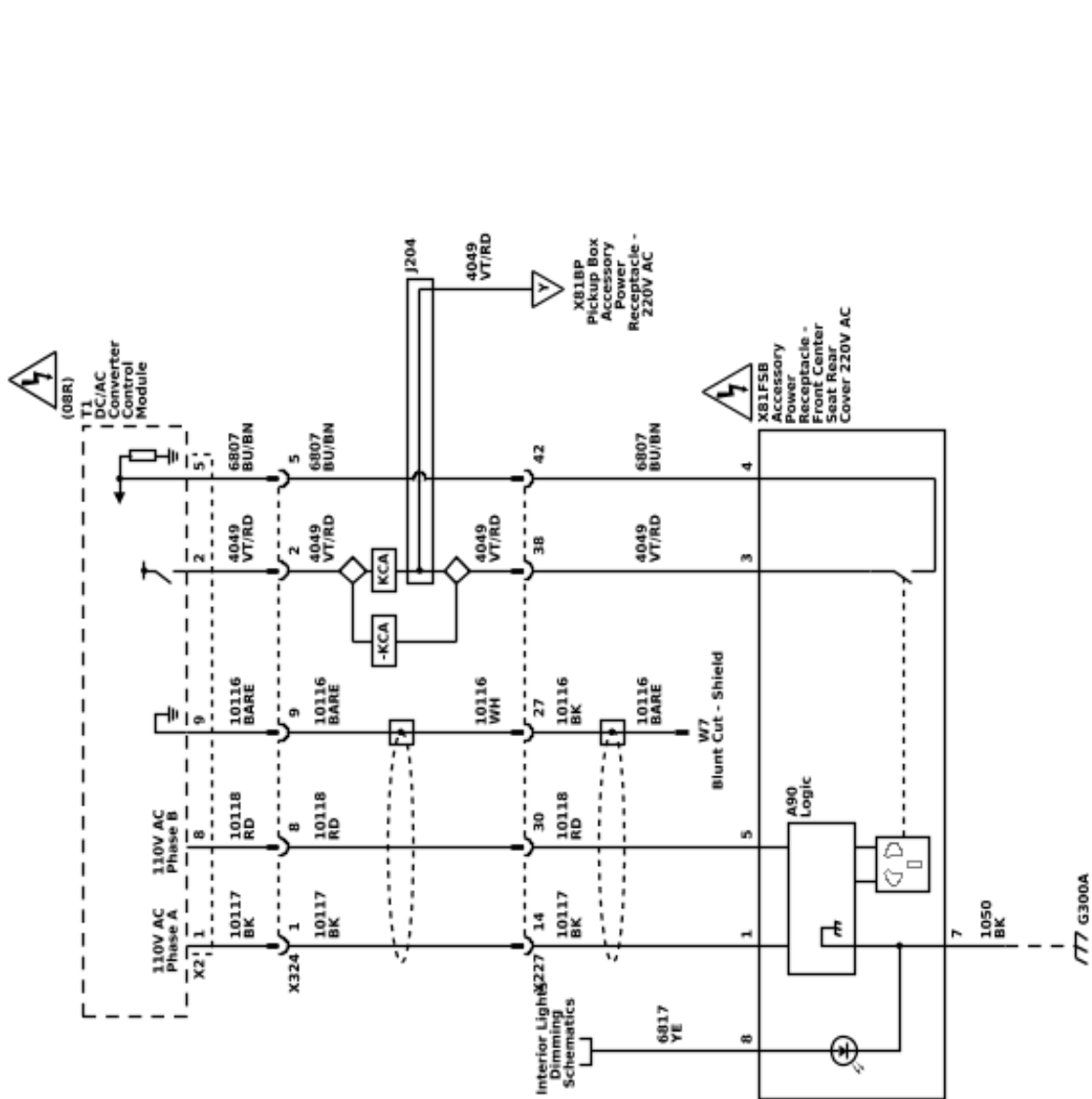

6278943

Cigar Lighter/Power Outlet Schematics (110V AC Accessory Power Receptacle - Instrument Panel (KI4 & - AZ3 & - D07))

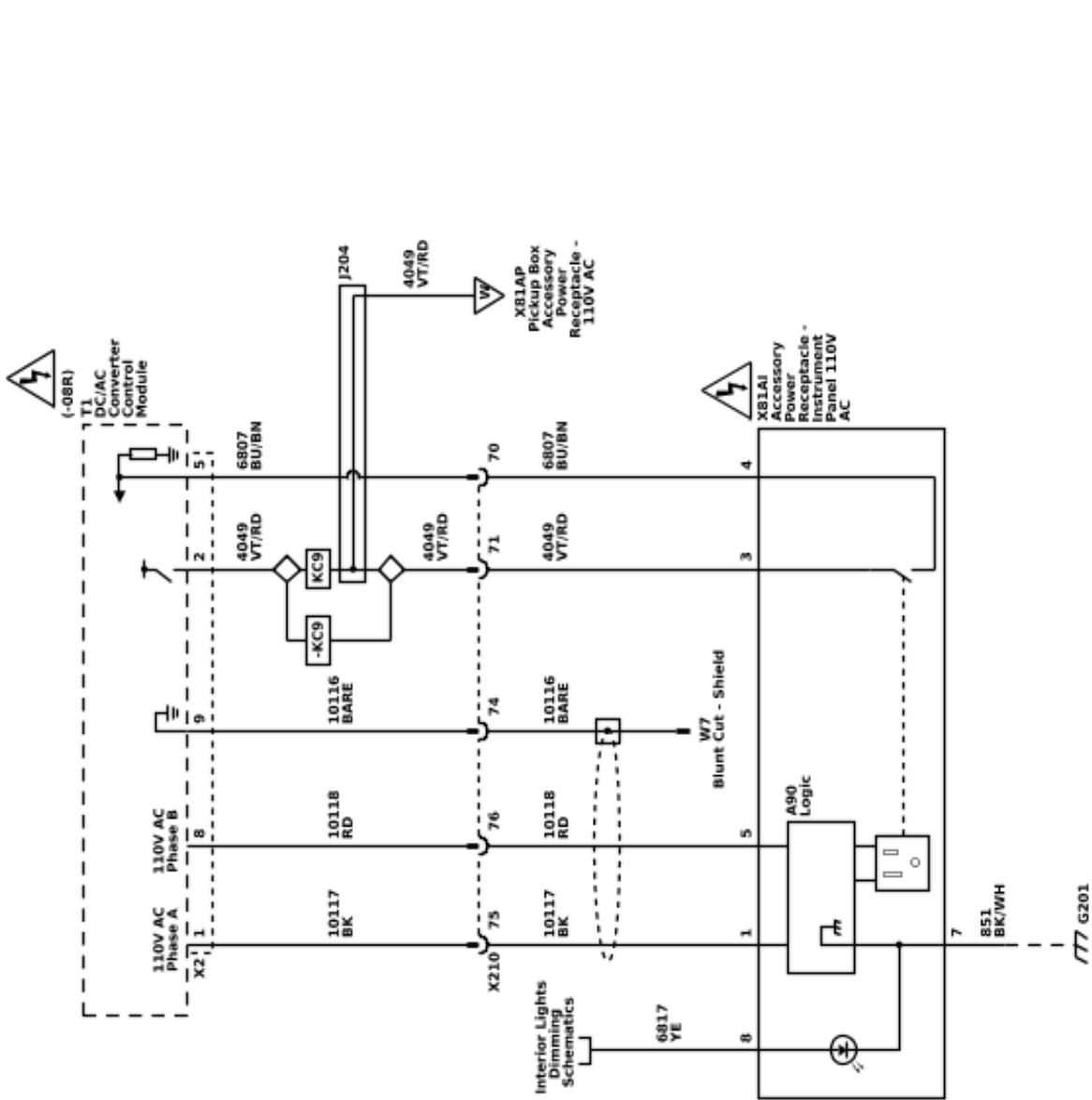

Cigar Lighter/Power Outlet Schematics (220V AC Accessory Power Receptacle - Instrument Panel (KI5 & - AZ3 & - D07))

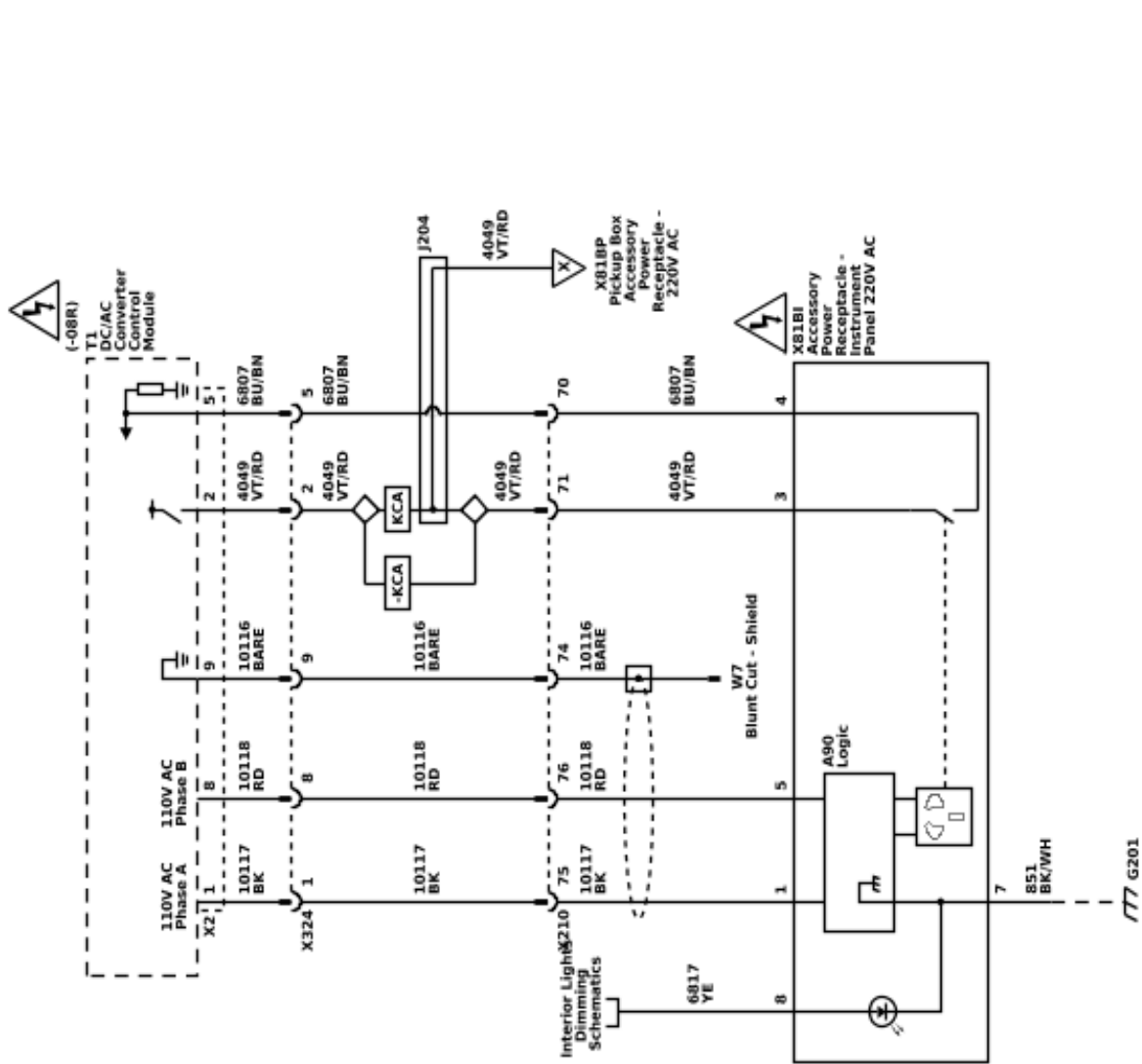

6278945

Cigar Lighter/Power Outlet Schematics (110V AC Pickup Box Accessory Power Receptacle (KC9))

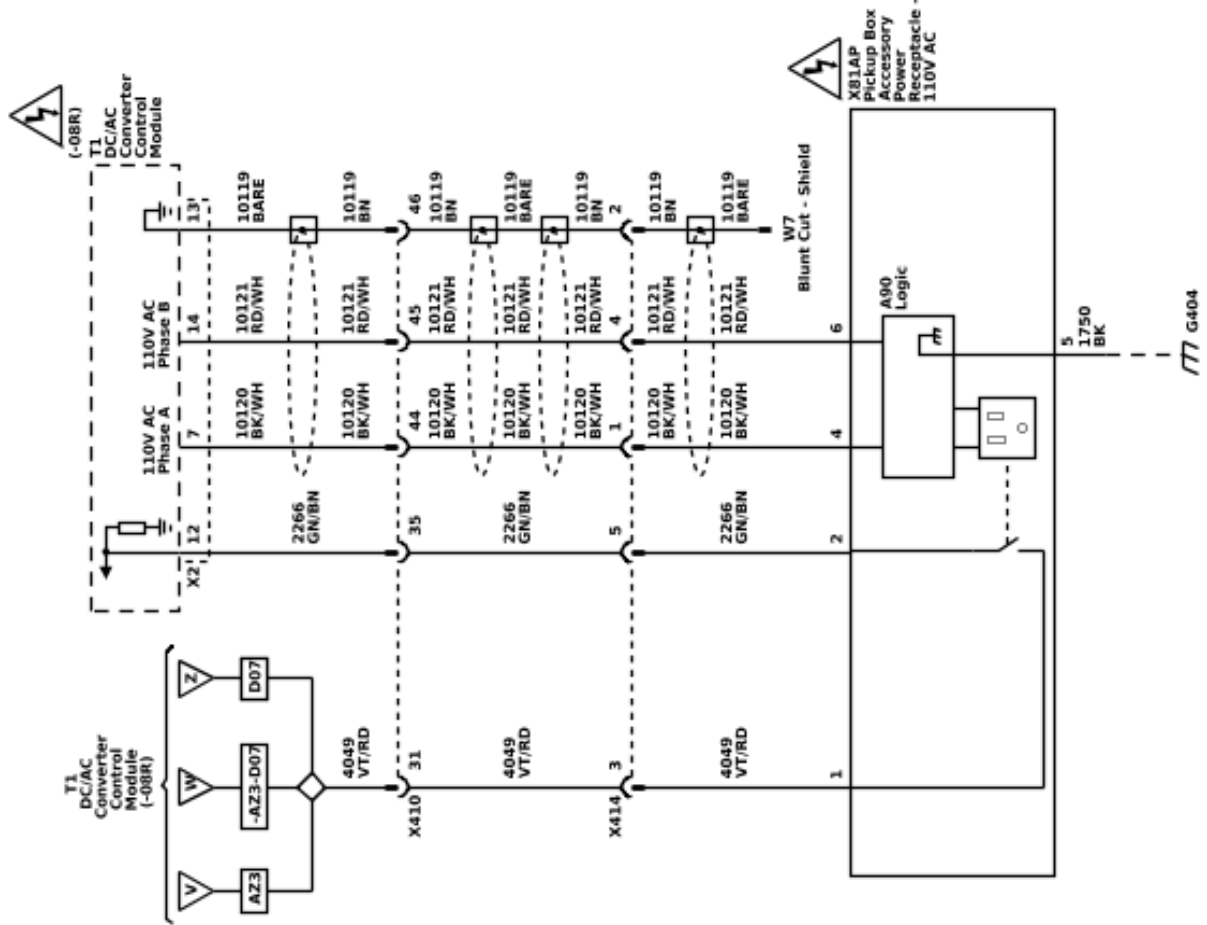



Cigar Lighter/Power Outlet Schematics (220V AC Pickup Box Accessory Power Receptacle (KCA))

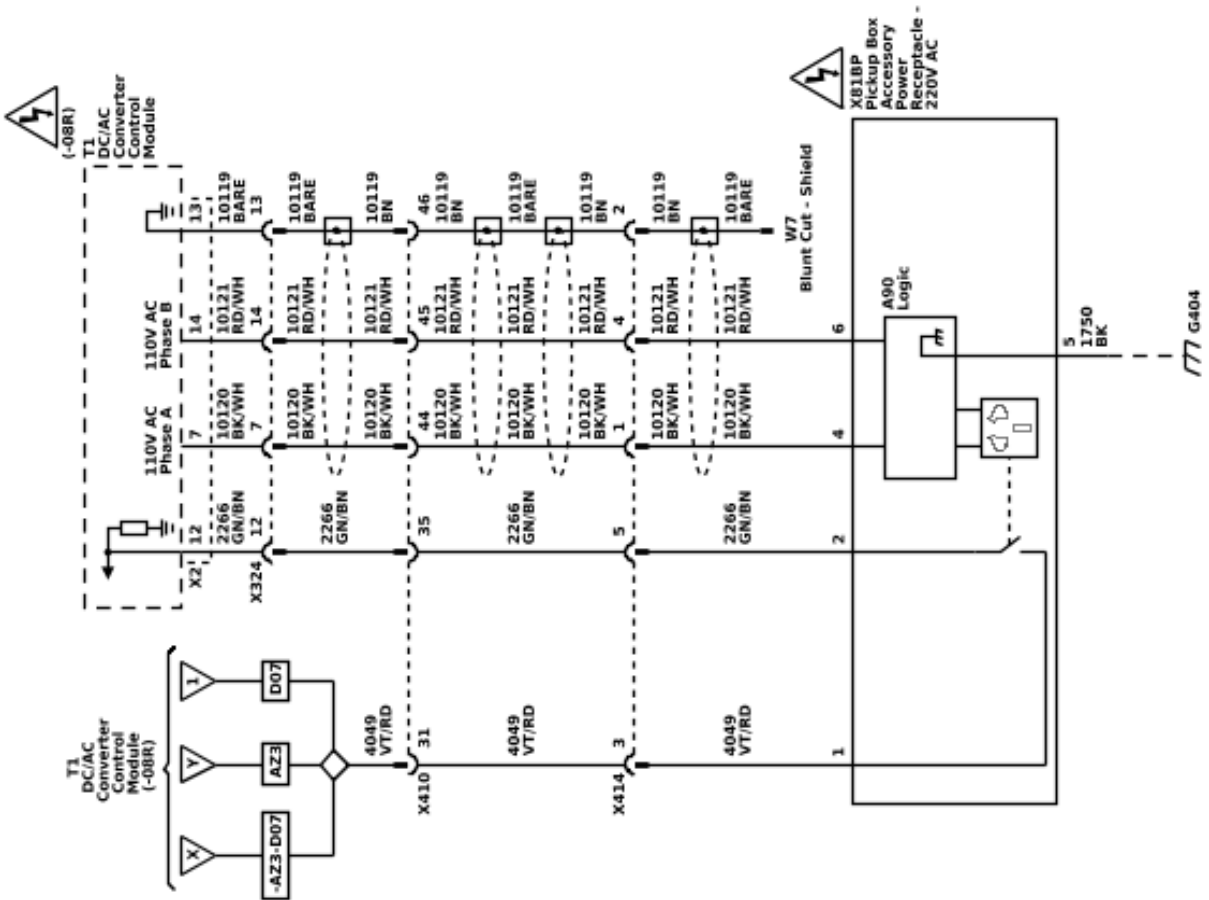

Cigar Lighter/Power Outlet Schematics (Wireless Charging (K4C))

LOC

DES

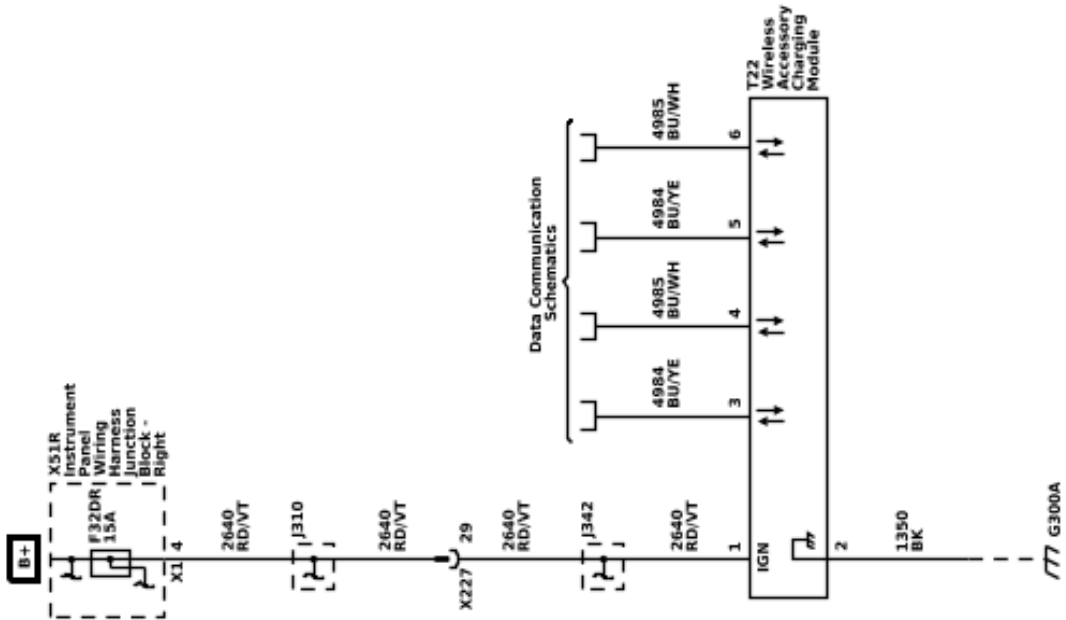

## Description and Operation

### Mobile Device Wireless Charger

#### Description and Operation

### Mobile Device Wireless Charging System

The Mobile Device Wireless Charging System (WCS) is an system for wirelessly charging mobile devices. It is capable of charging the batteries of compatible mobile devices. A compatible device is one that is compliant with Power Matters Alliance (PMA), Wireless Power Consortium (WPC) Standard, or Alliance for Wireless Power (A4WP), meaning that it is equipped with a PMA, WPC, or A4WP wireless charge “receiver” that will work with the charge “transmitter” installed in the vehicle. The devices may utilize built-in charging circuitry or an adapter (external plug-in device which contains the charging circuitry). To check for phone or other device compatibility, refer to GM Total Connect.

**Warning: Remove all objects from the charging pad before charging your mobile device. Objects, such as coins, keys, rings, paper clips, or cards, between the phone and charging pad will become very hot. On the rare occasion that the charging system does not detect an object, and the object gets wedged between the phone and charger, remove the phone and allow the object to cool before removing it from the charging pad, to prevent burns.**

### Charging

To charge a device, place it on the charging surface in the vehicle. There is a charging coil located in the center of the charging surface. The device has a charging coil typically near the center of the device. These coils must be lined up in order for charging to proceed. When the interruptible retained accessory power (IRAP) relay is closed (this is true typically when vehicle ignition is in Run or Accessory position), the WCS will detect the device, establish communications with the device to confirm it is a compatible device, and then deliver charging power to the device via wireless interface. The WCS will be able to deliver 5W to 15W of power as requested by the compatible device. It shall only enter a charging state if communication is established and a compatible device is identified.

The WCS shall not enter a charging state if there is no communication established with a compatible device. Due to differences in objects, a foreign object detection protocol is employed to detect a non-compliant device and hold power transfer initiation until the non-compliant object has been removed and a compliant object has been detected. The charger monitors its internal temperature and will shut down if the charger temperature exceeds 185F (85C).

### Indicator

The body control module will detect the device battery is charging and send a serial data message on the GMLAN bus to the radio display. The radio display will indicate a device is currently charging by displaying a lightning bolt over the phone icon. When the indicator is toggling on and off this indicates a thermal limit has been reached and the device will not charge. For more information refer to the owners manual.

### Cooling

The wireless charger is kept cool using the HVAC system. There is a dedicated HVAC duct that connects to the Wireless Charging Module bracket (which holds the module and the mat).

## Power Outlets Description and Operation

### 12 Volt Power Outlet Receptacle

#### Description and Operation

The 12 V accessory power receptacles are supplied with power by the accessory relay.

The vehicle is fitted with a cigarette lighter and/or with a 12 V accessory power receptacle. The cigarette lighter and accessory power outlets are controlled by an ignition operated relay. The accessory power receptacle and cigarette lighter are operational when the ignition is turned to either the On or the Accessories positions. To operate the cigarette lighter, press in the lighter knob. When the element is hot, the lighter automatically pops out and is ready for use.

## 110 Volt Power Outlet Receptacle System Description

### Power Outlets Block Diagram

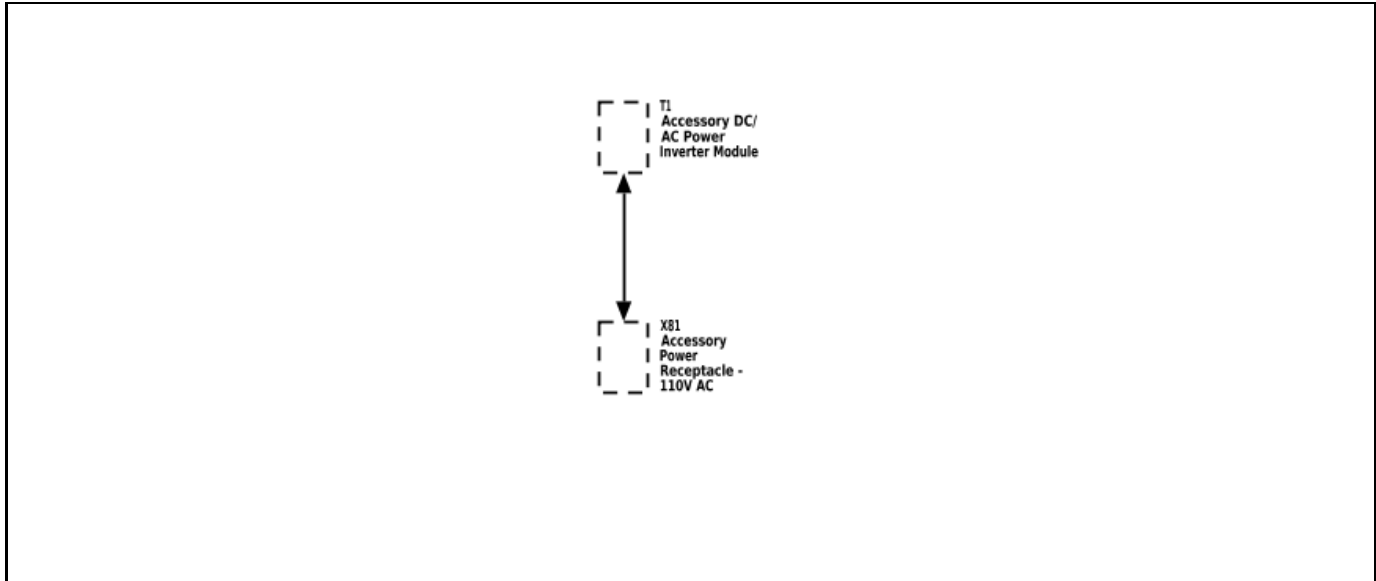

3403851

The alternating current (AC) accessory power outlet system consists of the accessory DC/AC power inverter module and the accessory power receptacle – 110 V AC. The accessory DC/AC power inverter module converts 12 V direct current (DC) battery power to 110 V at 60 Hertz (Hz) AC power to operate AC powered devices. The accessory DC/AC power inverter module provides up to 150 watts of power. The accessory power receptacle – 110 V AC provides the usual connection for AC powered devices.

### 110 Volt Power Outlet Receptacle System Operation

The accessory DC/AC power inverter module receives fuse protected battery voltage and is connected to the 12 V electrical system ground. The accessory power receptacle – 110 V AC has an internal switch, that detects when an AC powered device is plugged into the outlet. When the ignition is ON, and an AC powered device is plugged into the accessory power receptacle – 110 V AC, the normally open switch in the accessory power receptacle – 110 V AC, closes. When the accessory DC/AC power inverter module detects the voltage from the accessory power receptacle – 110 V AC switch, the inverter module begins to supply 110 V AC to the accessory power receptacle – 110 V AC after a 1.5 s delay. The accessory AC power system is protected against circuit overload and circuit shorts to ground.

### 110 Volt Power Outlet Receptacle Isolation Fault Protection

The accessory DC/AC power inverter module contains a ground fault circuit interrupter (GFCI). GFCI monitors the 110 V circuit for a short to vehicle chassis ground. If a 110 V AC short to ground is detected, the accessory DC/AC power inverter module will turn OFF. The module remains OFF, until the AC powered device is unplugged from the outlet, and then plugged into the outlet after a 3 s delay.

### 110 Volt Power Outlet Receptacle Overload Shutdown

The accessory DC/AC power inverter module will turn OFF if the current in the 110 V circuit is greater than 3.8 A for 1 s, or 2.5 A for 10 s. The module will turn ON again, when the AC powered device is unplugged from the outlet, and then plugged into the outlet after a 3 s delay.

### 110 Volt Power Outlet Receptacle Internal Shutdown

The accessory DC/AC power inverter module will turn OFF if the B+ supply voltage is greater than 16.5 V or less than 11 V. The module will also turn OFF if the device temperature is greater than 85°C (185°F). The module will turn ON again, after the shutdown condition is corrected, and the AC powered device is unplugged from the outlet, and then plugged into the outlet.

## 230 Volt Power Outlet Receptacle System Description

### Power Outlets Block Diagram

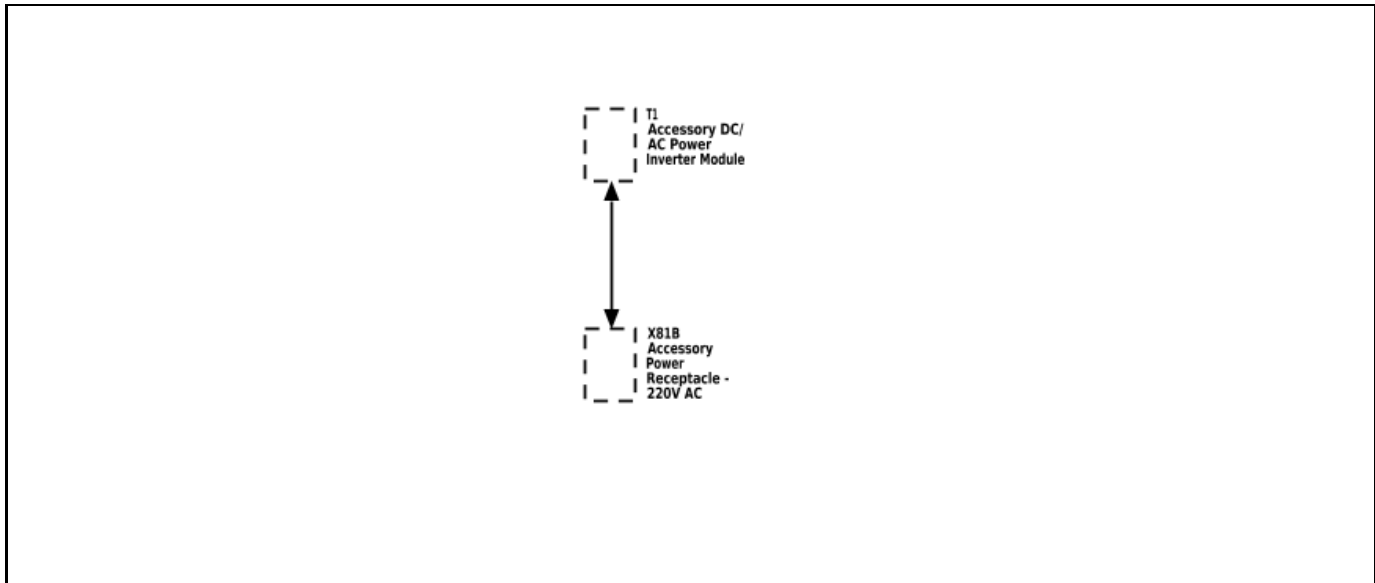

3403853

The alternating current (AC) accessory power outlet system consists of the accessory DC/AC power inverter module and the accessory power receptacle – 220V AC. The accessory DC/AC power inverter module converts 12 V direct current (DC) battery power to 220–230 V at 50 Hertz (Hz) AC power to operate AC powered devices. The accessory DC/AC power inverter module provides up to 150 watts of power. The accessory power receptacle – 220V AC provides the usual connection for AC powered devices.

### 230 Volt Power Outlet Receptacle System Operation

The accessory DC/AC power inverter module receives fuse protected battery voltage and is connected to the 12 V electrical system ground. The accessory power receptacle – 220V AC has an internal switch, that detects when an AC powered device is plugged into the outlet. When the ignition is ON, and an AC powered device is plugged into the accessory power receptacle – 220V AC, the normally open switch in the accessory power receptacle – 220V AC, closes. When the accessory DC/AC power inverter module detects the voltage from the accessory power receptacle – 220V AC switch, the inverter module begins to supply 220–230 V AC to the accessory power receptacle – 220V AC after a 1.5 second delay. The accessory AC power system is protected against circuit overload and circuit shorts to ground.

### 230 Volt Power Outlet Receptacle Isolation Fault Protection

The accessory DC/AC power inverter module contains a ground fault circuit interrupter (GFCI). GFCI monitors the 230 V circuit for a short to vehicle chassis ground. If a 230 V AC short to ground is detected, the accessory DC/AC power inverter module will turn OFF. The

module remains OFF, until the AC powered device is unplugged from the outlet, and then plugged into the outlet after a 3 s delay.

### 230 Volt Power Outlet Receptacle Overload Shutdown

The accessory AC/DC power control module will turn OFF if the current in the 230 V circuit is greater than 3.8 A for 1 second, or 2.5 A for 10 seconds. The module will turn ON again, when the AC powered device is unplugged from the outlet, and then plugged into the outlet after a 3 second delay.

### 230 Volt Power Outlet Receptacle Internal Shutdown

The accessory DC/AC power inverter module will turn OFF if the B+ supply voltage is greater than 16.5 V or less than 11 V. The module will also turn OFF if the device temperature is greater than 85°C (185°F). The module will turn ON again, after the shutdown condition is corrected, and the AC powered device is unplugged from the accessory power receptacle – 220V AC, and then plugged into the accessory power receptacle – 220V AC.

### USB Receptacle Description and Operation (USS)

The vehicle is fitted with USB charge port receptacles at the rear of the floor console. These USB receptacles are for charging devices only. The USB receptacles are controlled by an ignition operated relay and are operational when the ignition is turned to either the On or the Accessories positions.

# Wiring Systems and Power Management

## Description and Operation

### Power Mode Description and Operation

#### Serial Data Power Mode Master

The K9 Body Control Module (BCM) is the Power Mode Master and the K56 Serial Data Gateway Module is the Back-Up Power Mode Master.

The Power Mode Master uses various vehicle status conditions and inputs to determine the desired vehicle power mode state. The Power Mode (Off, Accessory, Run, Propulsion, Start) is communicated to other modules via Serial Data and other electrical signals in order to provide the proper feature operation for the appropriate power mode.

If the Power Mode Master cannot control or determine the correct Power Mode, the Backup Power Mode Master will take over and become the vehicle Power Mode Master and place the vehicle into the proper Power Mode by communicating with other modules via Serial Data to provide the proper electrical signals to provide the proper feature operation for the appropriate power mode.

#### S38 On/Off Vehicle Switch

There are 5 power modes to convey driver intent:

- OFF – A low power mode that allows maximum stand time until next start
- ACCY – Allows use of certain features that require operator authorization (Power windows for example). Propulsion is specifically disallowed.
- RUN – All features enabled except propulsion (motive force)
- PROPULSION – All features enabled
- START - This will transition to PROPULSION, including turning off non-essential loads to provide additional power for starting.

**Power Mode States**

Customer Action	Expected Vehicle Power Mode	S38 Vehicle On/Off Switch BCM Scan Tool Parameter	S38 Vehicle On/Off Switch Voltages
Vehicle OFF, S38 On/Off Vehicle Switch not pressed, Transmitter in Range	Vehicle Off Mode	Inactive	1.4 – 3.0 V (Switch Pressed) 3.35 – 4.26 V (Switch Released) 4.5 — 5.0 V (Switch Disconnected)
Vehicle OFF, S38 On/Off Vehicle Switch not pressed, Transmitter out of Range/ Away from vehicle	Vehicle Off Mode	Inactive	
Vehicle in any Power Mode EXCEPT OFF, then Press the S38 On/Off Vehicle Switch Foot On or Off the Brake Pedal, Transmitter in Vehicle	Vehicle Off Mode	Active (pushed) / Inactive (not pushed)	
Vehicle in Propulsion Mode, momentarily Press and Release the S38 On/Off Vehicle Switch Foot On or Off the Brake Pedal, Transmitter out of Range/Away from vehicle	Run Mode, With DIC Message No Remote Detected Press Brake to Restart	Active (pushed) Inactive (not pushed)	
Vehicle Off Power Mode, then Press the S38 On/Off Vehicle Switch for less than 5 s with foot Off the Brake Pedal; Transmitter in Vehicle	Vehicle Accessory Mode	Active (pushed) / Inactive (not pushed)	
Vehicle Off Power Mode, then S38 On/Off Vehicle Switch with foot On the Brake Pedal; Transmitter in Vehicle	Vehicle Start/Propulsion Mode (vehicle cranks then engine running (for Internal Combustion Engine) or Propulsion System Active for EV) power mode timeout is enabled	Active (pushed) / Inactive (not pushed)	
Vehicle Off Power Mode, then S38 On/Off Vehicle Switch with foot On the Brake Pedal for 5 to 10 s; Transmitter in Vehicle	Vehicle Start/Propulsion Mode (vehicle cranks then Propulsion Mode Active) power mode timeout will be disabled.	Active (pushed) / Inactive (not pushed)	
Vehicle OFF Power Mode, then Press and Hold the S38 On/Off Vehicle Switch for 5 s with foot Off the Brake Pedal; Transmitter in Vehicle	Vehicle Run Mode (Ignition ON without the Propulsion system Active)	Active (pushed) / Inactive (not pushed)	
Vehicle OFF Power Mode, then Press and Hold the S38 On/Off Vehicle Switch for 5 s with foot Off the Brake Pedal; Transmitter in Vehicle	Vehicle Start/Propulsion Mode (vehicle cranks then Propulsion Active) power mode timeout is disabled	Active (pushed) / Inactive (not pushed)	
Vehicle Propulsion Mode with vehicle speed detected above 4 km/h (2.5 MPH) press and hold S38 On/Off Vehicle Switch for 2 s or press and release it 2 times within 5 S.	Vehicle will transition from Propulsion Mode to Run Mode (Ignition On Propulsion system Inactive).	Active (pushed) / Inactive (not pushed)	
<b>NOTE: If the transmitter is not moved for more than 1 hour it will become inactive.</b>			



### Service Mode

Service Mode is the Run Power Mode with power mode timeout disabled. This can only be done with the Service Tool.

### Automatic Power Mode Timeouts

**Note:** If the Transmitter/Fob remains stationary and is not moved for one hour, it will go to sleep and may create a fob not in range condition.

This system is designed to prevent batteries from going dead in the event the ignition is left on while unattended, it is also designed to shut the vehicle off if left running unattended. After a Power Mode timeout, the Power Mode Master is responsible for shutting down the or transitioning the vehicle into the low parasitic sleep state "OFF" Power Mode. This Power Mode timeout strategy uses Vehicle Speed, Vehicle Power Mode, Parked Status and other Vehicle Conditions to make the timeout determination.

### Accessory Power Mode

The Accessory Power Mode will timeout after approximately 5 minutes. The timer will Start once the system has determined it is in the Accessory Power Mode status. After the timer expires the Power Mode will change to the OFF Power Mode.

### Run Power Mode

if the conditions listed below are met the Run Power Mode will timeout after approximately 40 minutes if the transmitter is in range, or 20 minutes if the transmitter is out of range. The timer will Start once the system has determined it is in the Run Power Mode status and all of the following conditions are met. After the timer expires the Power mode will change to OFF Power Mode.

If any of the following conditions are not met and/or if there is a change in the Brake Pedal or Clutch Pedal status, the Run Mode timeout timer will be disabled, and the timer will restart after all of the conditions are met again.

- Vehicle in Run Mode (Vehicle powered up S38 On/Off Vehicle Switch Green indicator on Propulsion Mode Inactive)
- Propulsion is Inactive
- Vehicle in Park.
- Vehicle Speed is 0 KM/MPH.
- Fast Idle is inactive (If Equipped).
- PTO Remote Start Status is inactive (If Equipped).
- Particulate Filter Cleaning Status is Inactive (if Equipped)
- S38 Vehicle On/Off switch was held for more than 5 to 10 seconds while starting the vehicle the actual time may vary based on model and/or year.

### Propulsion Power Mode

If the following conditions listed below are met the Propulsion Power Mode will timeout after approximately 30 minutes if the transmitter is in range, or 15 minutes if the transmitter is out of range. The timer will Start once the system has determined it is in the Propulsion Power

Mode status and all of the following conditions are met. After the timer expires the Power mode will change to the OFF Power Mode.

The Propulsion Power Mode timeout can be disabled with the vehicle in Off Power Mode, apply and continue to hold the brake pedal, then press and hold the S38 Vehicle On/Off switch for 5 to 10 seconds (the actual time may vary based on model and/or year). A DIC message will be displayed when Power Mode timeout is disabled.

If any of the following conditions are not met and/or if there is a change in the Brake Pedal or Clutch Pedal status, the Propulsion Mode timeout timer will be disabled, and the timer will restart after all of the conditions are met again.

- Vehicle in Propulsion Mode (Propulsion Active).
- Vehicle in Park.
- Vehicle Speed is 0 KM/MPH.
- Fast Idle is Inactive (If Equipped).
- PTO Remote Start Status is inactive (If Equipped).
- Particulate Filter Cleaning Status is Inactive (if Equipped)
- S38 Vehicle On/Off switch was held for more than 5 to 10 seconds while starting the vehicle the actual time may vary based on model and/or year.

### Relay Controlled Power Mode

The BCM uses discrete push button switch inputs, transmitter in range status, current power mode state, and brake pedal position state to distinguish the correct power mode (Off, Accessory Mode, Run Mode, Start/Propulsion Mode). The BCM, after determining the desired power mode, will activate the appropriate relays for that power mode.

The retained accessory power relay remains on for a timed period after the Ignition Mode is OFF. Refer to [Retained Accessory Power Description and Operation on page 6-980](#) for more information on the retained accessory power function.

### Push Button Start

The ignition mode switch has 2 LEDs that indicate the vehicle power mode Amber for Accessory Mode and Green for Run or Start/Propulsion Modes. When the vehicle is in the OFF mode, both LED's will be OFF. Momentarily pressing the S38 On/Off Vehicle Switch button once, brake pedal not applied, the vehicle will enter into the Accessory Mode and the Amber LED will illuminate. The Accessory Mode will timeout after approximately 5 min to help reduce battery drain. With the ignition OFF, brake pedal not pressed, then pressing and holding the S38 On/Off Vehicle Switch for 5 s will place the vehicle in Run Mode (Ignition ON without the Propulsion Mode Active). The vehicle will stay powered up for approximately 40 minutes if the transmitter is in range, or 20 minutes if the transmitter is out of range, and the Green LED will illuminate.

With the ignition OFF brake pedal pressed, then press and release the S38 On/Off Vehicle Switch, the vehicle will enter Start/Propulsion Mode and the Green LED will illuminate, the engine will crank and the engine will be running for Internal combustion engines (ICE), or Propulsion mode will go Active on Electric Vehicles (EV). The Propulsion Mode will timeout after



approximately 30 minutes if the transmitter is in range, or 15 minutes if the transmitter is out of range. The timer will stop when the vehicle is shifted out of PARK or the brake pedal is pressed and released, the timer will reset after the vehicle is placed back in PARK with the Propulsion Mode Active.

Both LED's have the voltage supplied from the body control module (BCM). The ignition mode switch sends the ignition mode switch status to the passive entry passive start module (PEPS) and to the BCM. The PEPS module sends a redundant signal to the BCM with the ignition mode switch status.

## Transport Mode

Transport Mode is designed to reduce the parasitic load of some modules during shipping and/or during vehicle storage. Some features may be disabled or have reduced functionality while Transport Mode is ON. Transport Mode is enabled and disabled by either of the following methods:

- With the Scan Tool Diagnostics > Body Control Module > Control Functions > Power Mode.
- Turning the hazard flashers ON, apply and hold the brake pedal, then press and hold the ignition mode switch for greater than 15 s. For vehicles equipped with a DIC a message Transport Mode On when it is enabled and Transport Mode Off when it is disabled will be displayed for a predetermined amount of time. For vehicles equipped without a DIC, the battery indicator light will constantly flash on the Instrument Cluster when Transport Mode is enabled.

## Battery Saver Mode

There are 7 different Battery Saver Modes. Battery Saver Modes 1 to 3 occur in Accessory and Run Power Modes (vehicle on propulsion system Inactive) if the battery voltage drops below approximately 11.5 V. Battery Saver Modes 4 to 7 occur in the Off Power Mode only. Battery Saver Modes 4 to 7 may set DTC's.

- Battery Saver Mode 1: DIC message "Battery Low, Start Vehicle", 4 chimes
- Battery Saver Mode 2: DIC message "Battery Low, Start Vehicle", Load Shed Level 3 is activated
- Battery Saver Mode 3: DIC message "Battery Low, Start Vehicle", Radio/Infotainment shut off, Load Shed Level 3 active
- Battery Saver Mode 4: Battery Saver Mode Ignition Off – Parasitic Current draw of 100 mA or greater
- Battery Saver Mode 5: Battery Saver Mode Ignition Off – Parasitic Current draw of 1 A or greater
- Battery Saver Mode 6: Battery Saver Mode Ignition Off – Battery Voltage less than 12.0 V
- Battery Saver Mode 7: Battery Saver Mode Ignition Off – Battery Voltage less than 11.6 V

## Load Shedding

Prior to Load shedding Idle Boost will occur, the idle speeds will be increased by 25 to 300 RPM to help maintain a normal battery voltage. Idle Boost may be noticeable to the driver. If the battery voltage continues to drop below a normal state then load shedding will go

active and it will start to reduce electric loads for components that will not impact the safe operation of vehicle. At load shed levels 2 and 3 a DIC message will be displayed "Reducing Features To Save Battery". When load shedding is active the customer may begin to notice features starting to have reduced functions or may become inoperative. Examples of affected loads are radio, HVAC blower(s) front and rear (if equipped), heated/ventilated seats, heated mirrors, rear defogger and other devices with heavy electrical draws. Idle Boost and load shed levels can be observed with the scan tool.

### Idle Boost 1

Idle is increased by 25-100 RPM and generally is not noticeable to most drivers.

### Idle Boost 2

Idle is increased by 50–200 RPM and generally is not noticeable to most drivers.

### Idle Boost 3

Idle is increased by 100–300 RPM and may be noticeable to most drivers.

### Load Shed Level 1

Reduces load current by 25%.

### Load Shed Level 2

Reduces load current by 50%.

### Load Shed Level 3

Electric loads for components that will not impact the safe operation of vehicle will be turned Off.

## BCM Awake/Sleep States

The BCM is able to control or perform all of the BCM functions in the awake state. The BCM enters the sleep state when active control or normal monitoring of system functions has stopped and a time limit has passed. The BCM must detect certain wake-up inputs before entering the awake state. The BCM monitors for these inputs during the sleep state.

The BCM will enter the awake state if any of the following wake-up inputs are detected:

- Activity on the serial data line
- Detection of a battery reconnect
- Any door open signal
- Headlamps ON
- Ignition ON
- Park lamps ON
- Keyless entry or remote start message

The BCM will enter a sleep state when all of the following conditions exist:

- Ignition OFF, transmitter is out of range
- No activity exists on the serial data line.
- No outputs are commanded.
- No delay timers are actively counting.
- No wake-up inputs are present.

If all these conditions are met, the BCM will enter a low power or sleep condition.

## Retained Accessory Power Description and Operation

### Retained Accessory Power

The Retained Accessory Power (RAP) & Interruptible RAP (IRAP) Circuits are controlled by the K9 Body Control Module (BCM). The BCM is the Power Mode Master, it utilizes various Vehicle inputs to determine the Vehicle Power Mode and sends this information via Serial Data and providing associated electrical signals to the entire vehicle for proper feature operation.

The BCM monitors the vehicles power modes, and door ajar/open switch status to determine whether the retained accessory power should be initiated and remain active or be terminated. The RAP output is optional based on the vehicles option contents. When utilized, the RAP Output control can be used to control a RAP Relay, it may provide direct power, or a serial data message to vehicle devices/modules from the BCM.

### Retained Accessory Power Relay Coil Control Circuit (If Equipped)

The BCM keeps the device or relay (if equipped) energized during all power modes, except Off-Awake and Crank. The device(s) remain active for approximately 10 min after the Vehicle is placed into the OFF Power Mode, provided none of the doors are opened.

Retained accessory power will end when one of the following conditions are met:

- The BCM receives an input from any door ajar switch indicating the opening of the door after the OFF Power Mode is achieved.

**Note:** If the BCM receives a door open/ajar active signal when the vehicle is placed into the OFF Power Mode, the retained accessory power will not initiate.

- The BCM internal timer for the retained accessory power expires after approximately 10 min.

Systems powered by the retained accessory power control circuit during the retained accessory power mode are as follows:

**Note:** The vehicle may not be equipped with all components as listed below.

- 12 V Accessory Power Receptacle
- Cigarette Lighter Receptacle
- Window Switches
- Sunroof Control Module (If Equipped)
- Sunroof Switch (If Equipped)
- Mobile Device Wireless Charger Module
- Mobile Telephone Control Module (If Equipped)
- Traffic Data Receiver (If Equipped)
- Transmission Shift Lever Position Indicator (w/ floor mounted console gear shift)

## Serial Data Controlled Retained Accessory Power

Retained accessory power systems controlled by serial data are as follows:

### Radio

Radio retained accessory power activation/termination is the same as relay operation with one exception; the only door that will turn the radio off during retained accessory power is the driver door open/ajar switch. The USB Ports will function the same as the radio.

### Vehicle Communication Interface Module (VCIM) (Onstar®) (If Equipped)

VCIM RAP activation/termination is the same as radio operation with 1 exception; if there is an active call and the vehicle is placed in the OFF Power Mode, the VCIM will remain in RAP mode, and keep the radio in RAP mode until the call is terminated.

## Interruptible Retained Accessory Power

The Power Mode Master (PMM) Controls components as needed. If equipped with a RAP relay, the BCM controls the Retained Accessory Power with an exception, Interruptible Retained Accessory Power (IRAP) is deactivated during transmitter authentication. During Transmitter Authentication the PMM will deactivate components including IRAP to prevent Radio Frequency (RF) Interference (RFI) that may cause a "NO REMOTE DETECTED" message to be displayed on the drivers information center.

**Note:** If transmitter Authentication occurs while in Run or Propulsion Modes, it is normal for IRAP to be interrupted momentarily (i.e. items connected to auxiliary power ports or chargers may momentarily go off then come back on).

If a remote transmitter was not been previously detected, Transmitter Authentication can occur under any of the following conditions:

- The drivers side front door is opened.
- The drivers side rear door is opened.
- The S38 Vehicle On/Off Switch is pressed.

## Section 7

# Transmission

<b>Shift Lock Control</b> .....	<a href="#">7-3</a>
<b>Schematic and Routing Diagrams</b> .....	<a href="#">7-3</a>
Shift Lock Control Schematics (MHT/ MQB/MQE) .....	<a href="#">7-4</a>
<b>Description and Operation</b> .....	<a href="#">7-5</a>
Automatic Transmission Shift Lock Control Description and Operation .....	<a href="#">7-5</a>

**BLANK**

# Shift Lock Control

## Schematic and Routing Diagrams

Shift Lock Control Schematics (MHT/MQB/MQE) (Shift Lock Control)

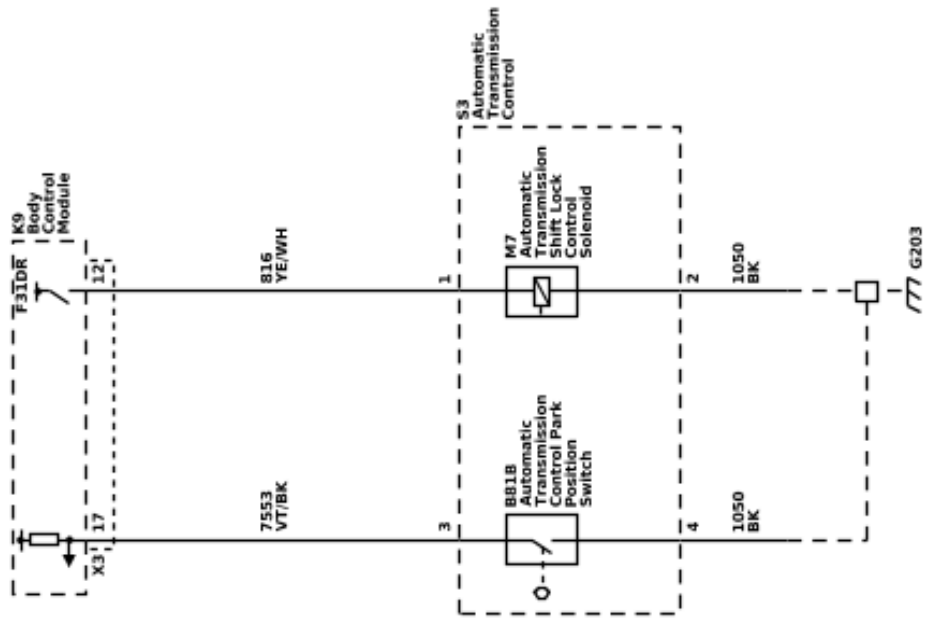

## Description and Operation

### Automatic Transmission Shift Lock Control Description and Operation

The Automatic Transmission Shift Lock Control System is a safety device that prevents an inadvertent shift out of PARK when the engine is running. The driver must press the brake pedal before moving the shift lever out of the PARK position. The system consists of the following components:

- The Automatic Transmission Shift Lock Solenoid (serviced as the Automatic Transmission Shift Lock Actuator)
- The Body Control Module (BCM)
- The Engine Control Module (ECM)

The BCM controls the voltage to the shift lock control solenoid through the shift lock control solenoid controlled voltage circuit. The following conditions must be met before the BCM will supply voltage to the shift lock control solenoid:

- The ignition is in the ON position.
- The ECM sends an input via GMLAN serial data to the BCM when the Transmission Control Module (TCM) indicates the transmission is in the PARK position.
- The BCM receives a brake applied input from the stop lamp switch.

Since the shift lock control solenoid is permanently grounded, the BCM supplies voltage to the automatic transmission shift lock control solenoid, releasing the mechanical lock on the shift lever as the solenoid energizes. The energized solenoid allows the driver to move the shift lever out of the PARK position. When the brake pedal is not applied, the BCM turns the control voltage output of the shift lock control solenoid OFF, de-energizing the shift lock control solenoid. When the transmission is in the PARK position, the de-energized shift lock control solenoid will prevent shifting as the lever is mechanically locked in the PARK position.

During remote start operation the BCM will de-energize the automatic transmission shift lock control circuit, locking the shift lever in the PARK position.

**BLANK**



<b>A</b>	<b>P</b>
Automatic Day-Night Mirror Description and Operation ..... <a href="#">2-54</a>	Power Door Locks Description and Operation ..... <a href="#">2-84</a>
Automatic HVAC Description and Operation ..... <a href="#">5-24</a>	Power Mode Description and Operation ..... <a href="#">6-974</a>
<b>B</b>	<b>R</b>
Battery Description and Operation ..... <a href="#">4-9</a>	Power Outlets Description and Operation ..... <a href="#">6-971</a>
<b>C</b>	Power Windows Description and Operation ..... <a href="#">2-11</a>
Charging System Description and Operation ..... <a href="#">4-9</a>	<b>R</b>
Component Connector End Views ..... <a href="#">6-78</a>	Rear Vision Camera Description and Operation ..... <a href="#">3-7</a>
<b>D</b>	Rear Window Defogger Description and Operation ..... <a href="#">2-11</a>
Data Link Communications Description and Operation ..... <a href="#">6-27</a>	Rearview Camera Camera Full Display Mirror Description and Operation ..... <a href="#">3-7</a>
Door Ajar Indicator Description and Operation ..... <a href="#">2-82</a>	Retained Accessory Power Description and Operation ..... <a href="#">6-977</a>
<b>E</b>	RPO Code List ..... <a href="#">1-8</a>
Electrical Center Identification Views ..... <a href="#">6-30</a>	<b>S</b>
Electrical Power Management Description and Operation ..... <a href="#">4-12</a>	Schematics
Endgate Description and Operation ..... <a href="#">2-82-2-84</a>	Body Control Systems ..... <a href="#">6-24</a>
Exterior Lighting Systems Description and Operation ..... <a href="#">2-40</a>	Cigar Lighter/Power Outlet ..... <a href="#">6-960</a>
<b>H</b>	Data Communications ..... <a href="#">6-4</a>
Harness Routing Views ..... <a href="#">6-912</a>	Defogger ..... <a href="#">2-10</a>
Heater and Air Conditioning System Description and Operation ..... <a href="#">5-16</a>	Door Lock/Indicator ..... <a href="#">2-70</a>
Hood Ajar Indicator Description and Operation ..... <a href="#">2-84</a>	Endgate ..... <a href="#">2-77</a>
Horn System Description and Operation ..... <a href="#">2-14</a>	Exterior Lamps ..... <a href="#">2-21</a>
<b>I</b>	Fog Lamps ..... <a href="#">2-20</a>
Inline Harness Connector End Views ..... <a href="#">6-745</a>	Headlamps/Daytime Running Lamps ..... <a href="#">2-16</a>
Inside Rearview Mirror Replacement ..... <a href="#">2-49</a>	Hood Latch ..... <a href="#">2-81</a>
Interior Lighting System Description and Operation ..... <a href="#">2-43</a>	Horns ..... <a href="#">2-13</a>
<b>M</b>	HVAC ..... <a href="#">5-4</a> , <a href="#">5-10</a>
Manual HVAC Description and Operation ..... <a href="#">5-35</a>	HVAC Systems - Automatic ..... <a href="#">5-18</a>
Mobile Device Wireless Charger Description and Operation ..... <a href="#">6-971</a>	HVAC Systems - Manual ..... <a href="#">5-29</a>
<b>O</b>	Image Display Cameras ..... <a href="#">3-4</a>
Outside Mirror Description and Operation ..... <a href="#">2-55</a>	Inside Rearview Mirror ..... <a href="#">2-45</a>
	Interior Lamps ..... <a href="#">2-34</a>
	Interior Lamps Dimming ..... <a href="#">2-36</a>
	Moveable Window ..... <a href="#">2-4</a>
	Outside Rearview Mirror ..... <a href="#">2-46</a>
	Release Systems ..... <a href="#">2-76</a>
	Shift Lock Control ..... <a href="#">7-4</a>
	Starting and Charging ..... <a href="#">4-4</a>
	Trailer Systems ..... <a href="#">2-58</a>
	Shift Lock Control Description and Operation ..... <a href="#">7-5</a>
	Starting System Description and Operation ..... <a href="#">4-14</a>
	Stop/Start System Description and Operation ..... <a href="#">4-15</a>
	Surround Vision Camera Description and Operation ..... <a href="#">3-7</a>

**T**

Trailing Description and Operation ..... [2-63](#)  
Trailing Systems Schematics ..... [2-58](#)  
Training ..... [1-3](#)

**V**

Vehicle Certification, Tire Placard, and Anti-Theft  
Label ..... [1-5](#)  
Vehicle, Engine and Transmission ID and VIN  
Location, Derivative and Usage ..... [1-4](#)