

Subject: Installation of Upfitter (AUX) Switches (9L7) components
Models Years 2024-Current
Affected:
Models Affected Full-size GMC Trucks – Premium Uplevel Trim
Denali/Ultimate/AT4/AT4X
Origination Date: 10/24/2024
Revision Date: N/A

ADVISORY:

<u>UI Bulletin Usage Table</u>			
<u>Model Year(s)</u>	<u>Brand</u>	<u>Model</u>	<u>Bulletin #</u>
2024-2025	GMC	2500/3500 Denali/AT4	205

Condition/Concern:

Beginning with the 2022i the Full-Size Pickup Trucks, the Upfitter (AUX) Switch option (9L7) will require, depending on model, some or all components will need to be installed to make the feature fully functional. The installation instructions vary by vehicle trim levels and those instructions are broken down by trim option codes.

Install Procedure #1 = Chevy WT (GF5), Custom (GF2), Custom TB (GPZ), and GMC Pro (GFF) - [UI TSB 193](#)

Install Procedure #2 = LT (GG0/GF3), LT TB (GF4), RST (GFC), ZR2 (GRZ), LTZ (GF9), HC (GFD), SLE (GFI), Elevation (GFS/GFJ), SLT (GFU) - [UI TSB 193](#)

Install Procedure #3 = AT4 (GFG), AT4X (GA4), Denali (GFW), Denali Ult (GFY) - UI TSB 205

The 9L7 upfitter (AUX) switch components consist of the following:
(components vary based on trim level)

- Console cover
- Switch Bank
- Fuse Kit
- Fasteners (2)
- Aux Fuse Block
- Under Hood Wiring harness
- Retainers

Light Duty models (1500)

~~These models will require all the listed components to be installed. The components are shipped in various locations within the cab of the truck.~~

Heavy Duty Models (2500/3500)

These models are currently being manufactured with the switches and appropriate console panels installed yet require remaining components in the list to be installed.

Service Parts for Retrofit

The retrofit parts will require all components to be installed. The part numbers and the list of components are noted below.

NOTICE:

Installation of the Upfitter (AUX) Switches and supporting components are NOT a GM Warranty or PDI covered labor cost. The installation of the switches/components are intended to be performed by the upfitter as a part of the overall vehicle upfit and the labor cost associated with that installation be covered in the upfitter's estimate to its customer. Installation, when performed by a GM dealer, the labor charges associated with that install are the responsibility of the customer/vehicle purchaser.

Power Cable installation/routing (all trim levels)

To route the power wire harness into the cabin the LH inner wheelhouse liner must be removed to gain access to the "service" port where the wire will be passed through. Select the appropriate removal procedure by vehicle application within the linked document below.

Combined Front Wheelhouse Liner Replacement procedures

Prior to attempting to pass the wire/harness into the cabin the silver-colored insulation and plastic conduit must be removed, leaving only fabric like tape wrapping on the wire.



The “service port” or wire pass-thru is located at the 6 o’clock position on the wire harness grommet as shown below. The rubber seal inside of the service port will need to have an “X” cut into to provide for the wire to be passed.

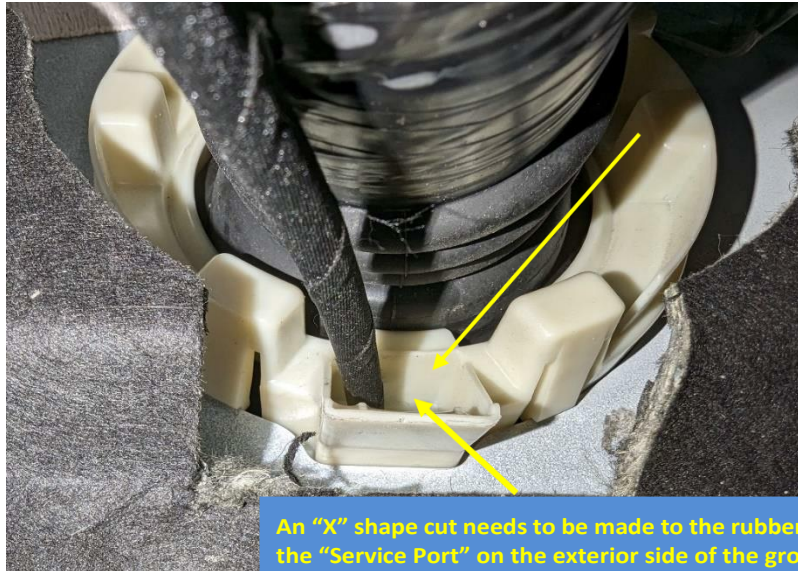

A similar “X” shape cut must be made to the interior cabin side of the grommet located under the IP on the LH side just below the HVAC module– see below.



Generously lubricate the exterior area of the service port with glass cleaner. Using a 6” to 8” rigid feeder wire (metal hanger type wire) taped the terminated end (non-ring terminal) of the harness. Feed the rigid feeder wire through the exterior service port using care to ensure the feeder wire exits inside the cab through the X cut. While applying support pressure to the inside X cut area, pull the feeder wire, and harness terminal through the X cut into the cabin. Once the terminated end of the harness is inside the cabin, continue to pull the harness into the cabin and route behind the HVAC duct as shown below. You will need to leave enough of the harness Under hood to route

General Motors Upfitter Integration

<http://www.gmupfitter.com>

up to the Battery Electrical Center (BEC) as you will adding content to the BEC to power the AUX Electrical Center that will be added in upcoming steps.



Route wire harness RH side to LH side of under IP, behind the HVAC extension duct that the Aux fuse block is secured to as shown. Secure excess with zip tie straps as needed to prevent rattles and drooping down below the IP.



To run the power harness to the fuse block two 6mm holes, need to be drilled to add access for retainer clip on these Denali and AT4 trucks. The holes are in the sheet metal but not in the plastic.



Install Procedure #3 = AT4 (GFG), AT4X (GA4), Denali (GFW), Denali Ult (GFY)

(Note for the new IP design kits are not yet available use P/Ns for obtaining parts for retrofitting a vehicle not ordered with the 9L7 option)

	Console Cover	Switch Bank	Fuse kit	Aux. Fuse Block + Switch harness	Wire Harness	Fasteners
P/N	85091037	85080553	84669070	85633439	84810191	11589015

Repair/Recommendation:

To install the Aux switches, the console will need to be partially disassembled which includes the Instrument panel lower trim panels. The console cover may require replacement or may simply need to have a few fasteners removed (if switches are installed during assembly refer to the vehicle model

sections below for details. **NOTE:** Prior to reinstalling the replacement console cover (if applicable) follow the instructions as follows.

1. You will need to remove the - [Front Floor Console Extension Panel - Left Side](#)
2. Removing both Left and right - [Front Floor Console Applique](#)

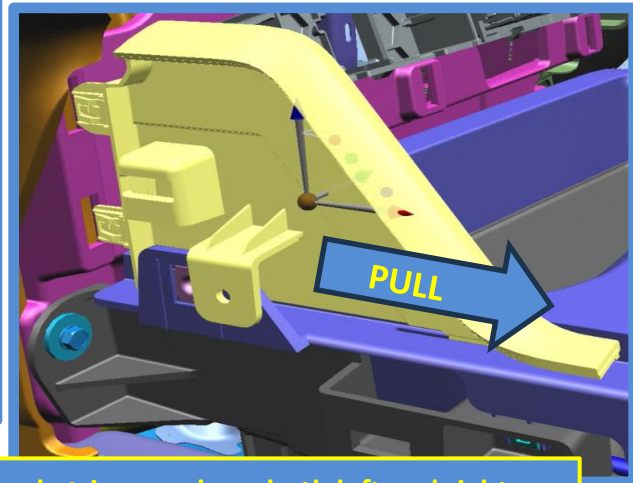
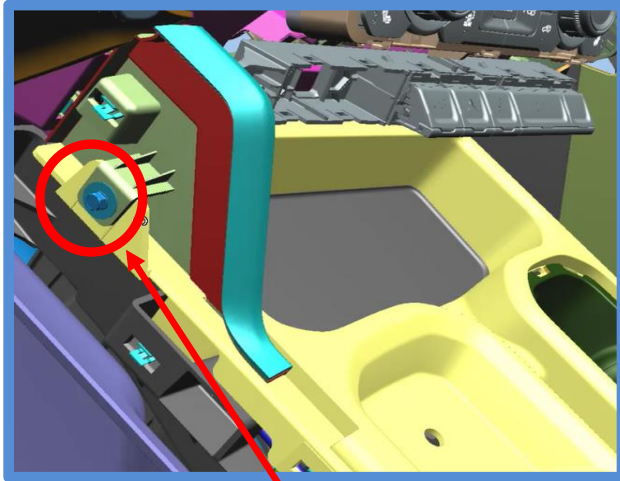

Next you need to remove the lower console trim panels on both left and right side by removing the screw and unclipping the panel from the IP.





When removing the Console panel, there are ten(10) retainer clips holding down this panel. Use a flat-bladed plastic trim tool. Caution when lifting as the USB, trailer brake controller, ignition lock key antenna, low frequency console antenna etc. will be attached. Disconnect Electrical connectors and release wiring harness retainers.

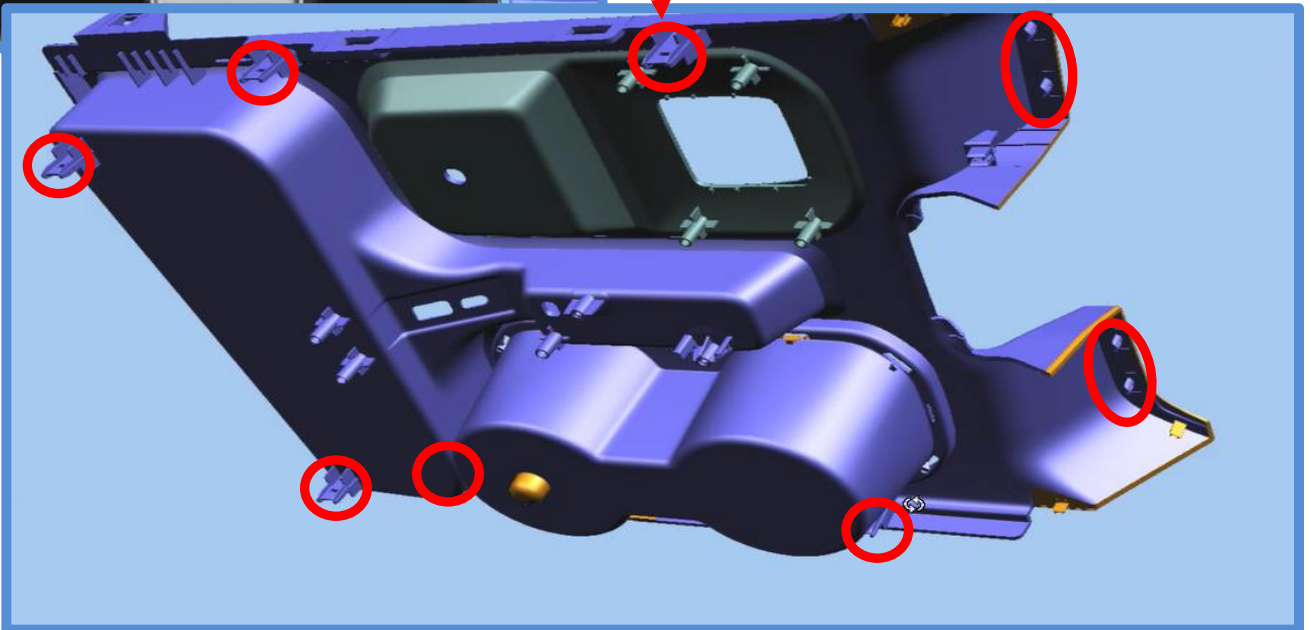
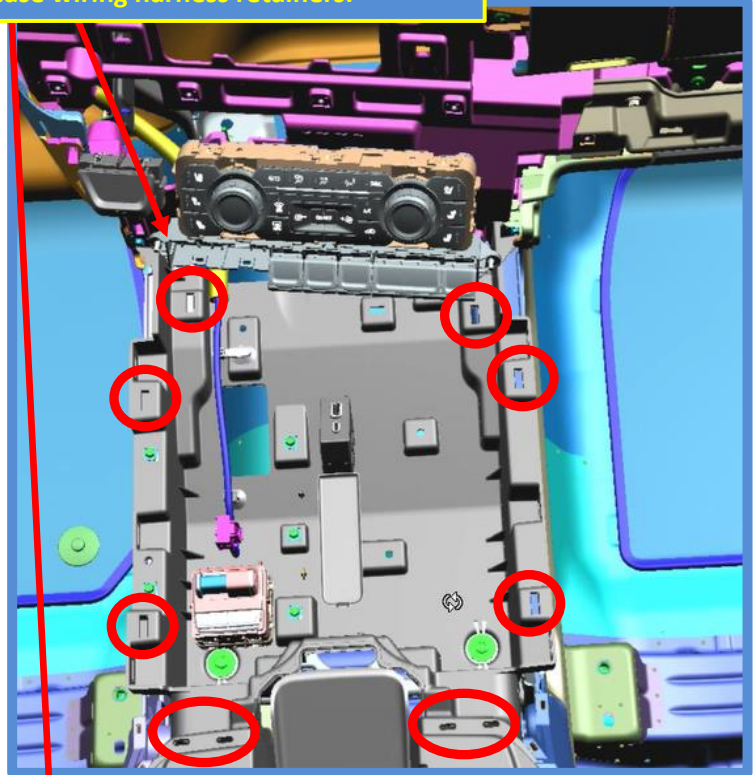

[Front Floor Console Cup Holder Trim Plate Replacement](#)

Electrical Center mounting/connections:

1. Remove the Knee Bolster trim panel using the procedure in the link below

[Instrument Panel Knee Bolster Replacement Non 1WT or 1CX trims](#)

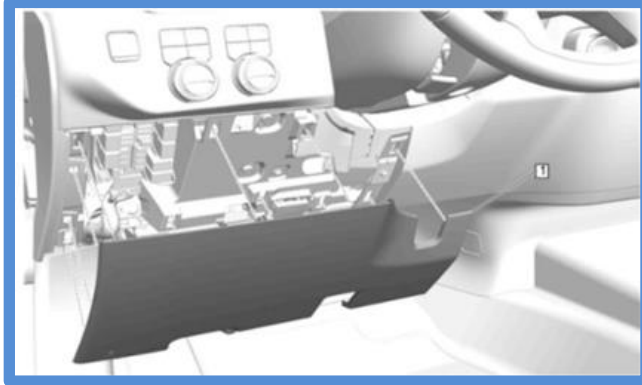

2. Mount the IP Aux. Fuse block using Zip ties on the front(engine side) of the driver's side HVAC extension duct under IP. Where the harness exits the aux fuse block, it should face toward drivers' outboard side, when the fuse block is mounted on the driver's side HVAC extension duct. Remove the u-nuts from the mounting ears of the aux fuse block. Apply two-sided tape to the aux fuse block, spanning between the two mounting ears. Insert a zip tie thru the hole for each of the mounting ears. Position the aux fuse block to the front (engine side) of the driver's side HVAC extension duct as shown, then secure the two-sided tape and zip ties. Add two additional zip ties, one on each mounting ear, positioned between the first zip ties and the body of the fuse block, as shown below.



General Motors Upfitter Integration

<http://www.gmupfitter.com>

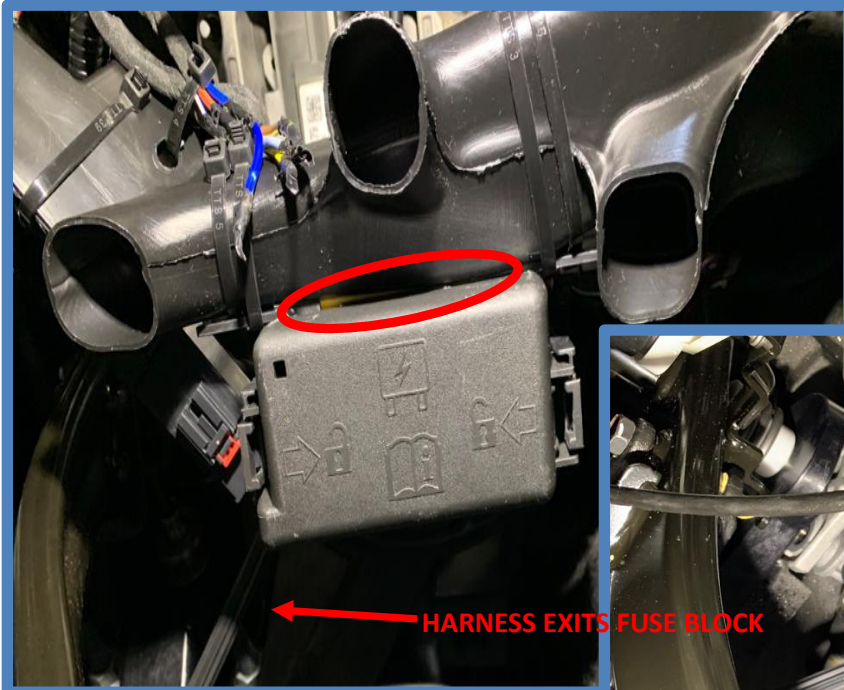

Connect the 14-pin connector Aux Fuse Block to the connector shown in figure 2 (note vehicle is shipped from the assembly plant with a blank connector in place to protect the terminals in the IP Harness. Remove this prior to connecting the connector from the fuse block)

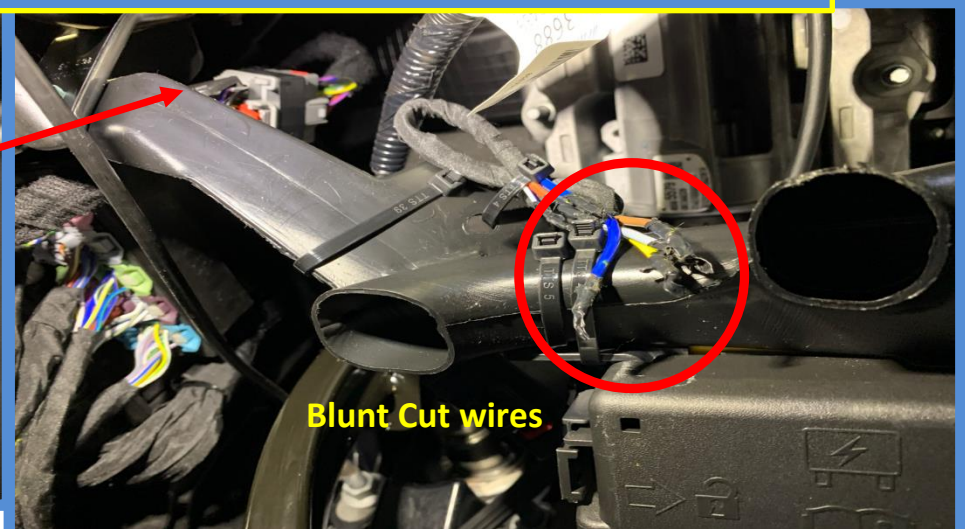
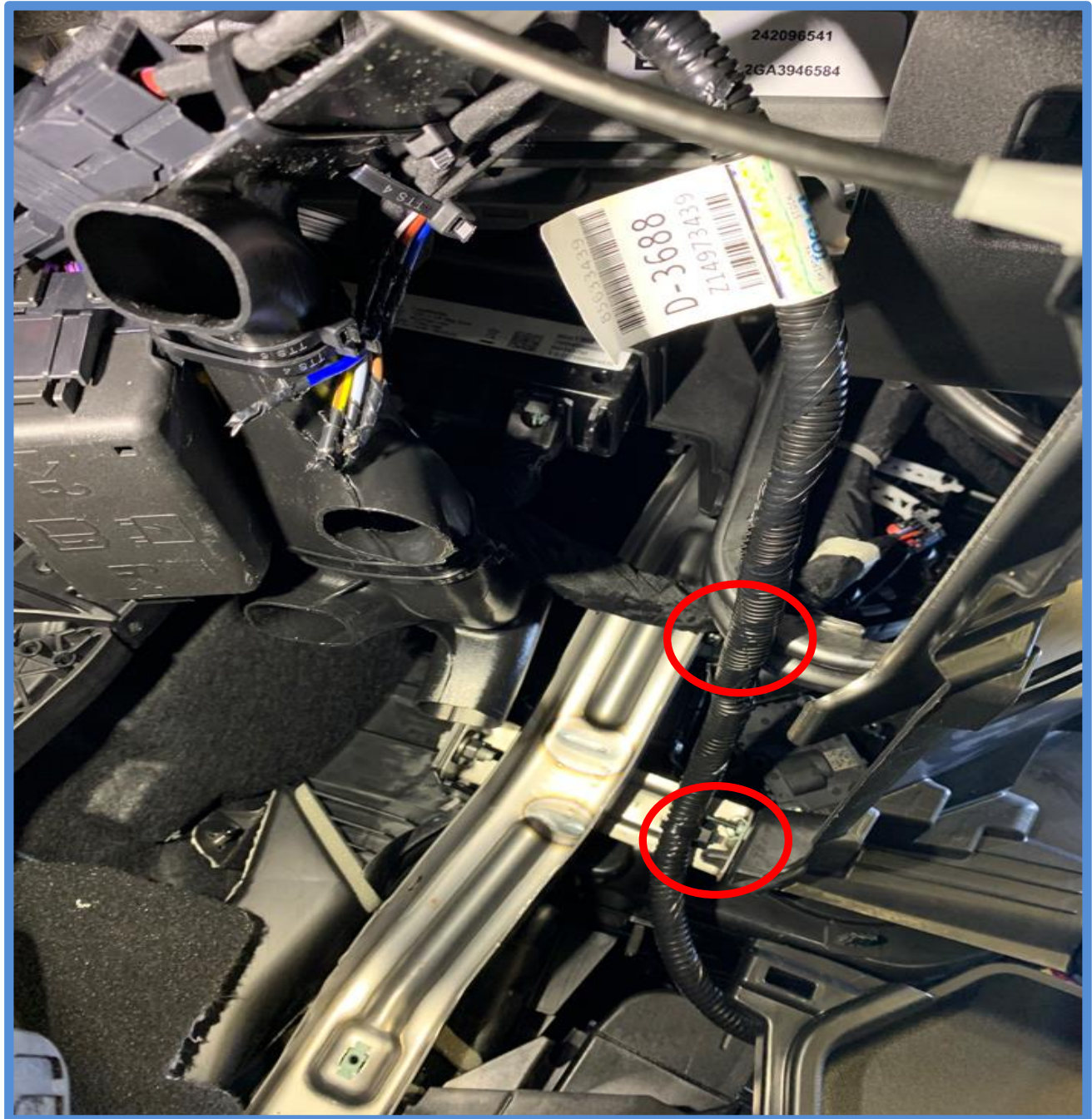

Figure 2

3. Route the 16-pin switch bank connector harness on the front side of the driver side HVAC extension duct meeting your first retainer clip on the IP. Through the opening in the IP illustrated below insert the retainer clip and continue to route the harness under the HVAC control center, continuing into the console securing the harness retainer clips as illustrated in figure 5. Retrofits will need to drill a 6mm hole to insert the final harness retainer clip see figure 5 for illustration.



General Motors Upfitter Integration

<http://www.gmupfitter.com>

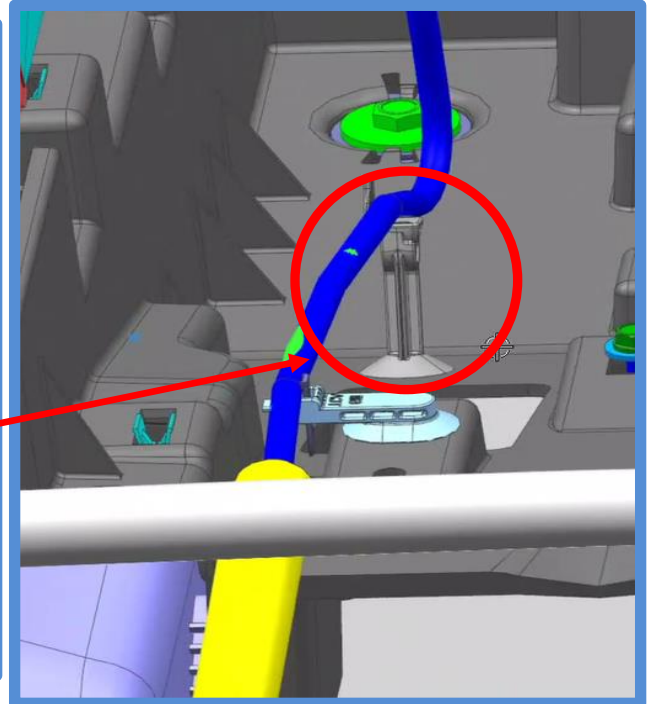
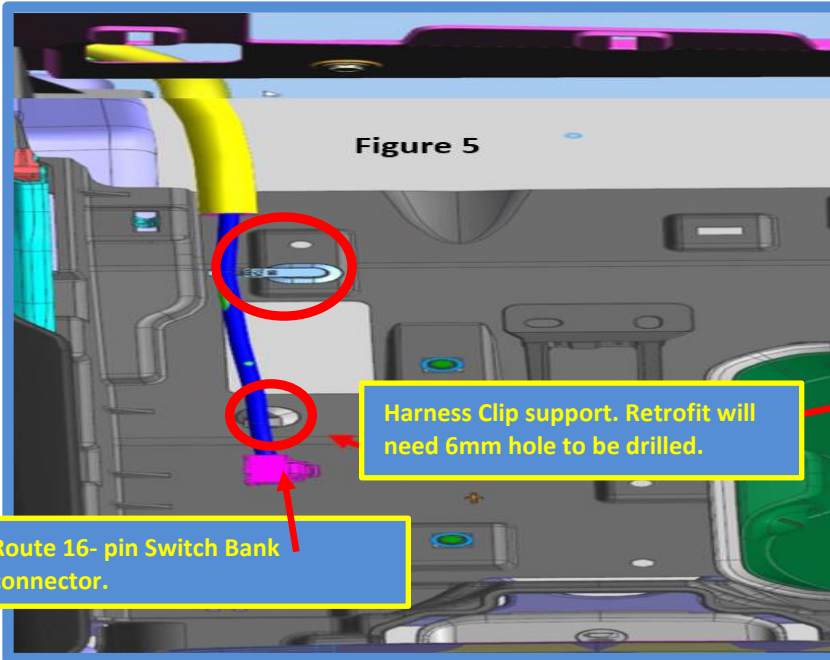

4. With switches installed into the new console panel in the provided cut-out. Connect the switch connector/harness and any other electrical connections – Installed the console panel and reassemble the removed components per the GM service procedures used to remove them, as listed throughout this bulletin.

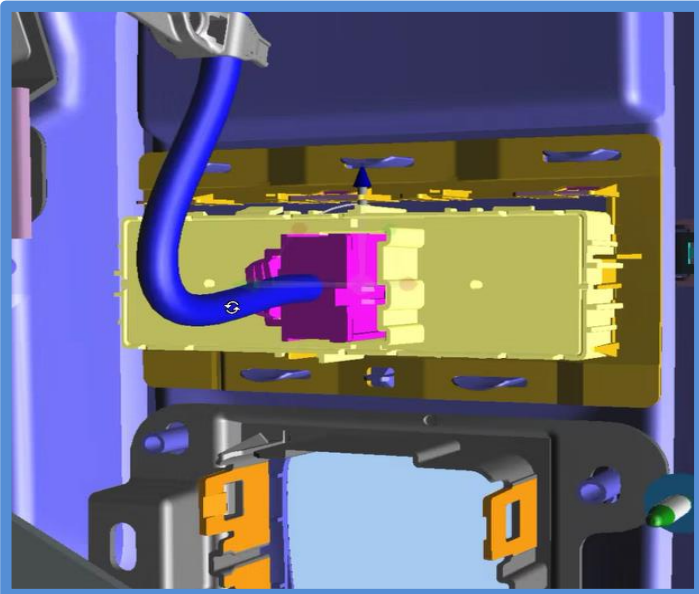

5. Install the provided connector body onto the power wire harness routed earlier from under-hood into the passenger compartment and connect to the Aux Electrical Center mating connector.

Adding Fuse Kit:

1. Once all "kit" components have been installed, the Aux Fuse Block can now be powered, for detailed instructions on adding the fuses to the battery mounted electrical center refer to the latest revision of UI Bulletin #147. (<http://www.gmupfitter.com/pages/technical-bulletins>)
2. Following the installation of the fuse kit to the battery mounted electrical center, connect the power cable ring terminal to the 60-amp fuse output side stud.

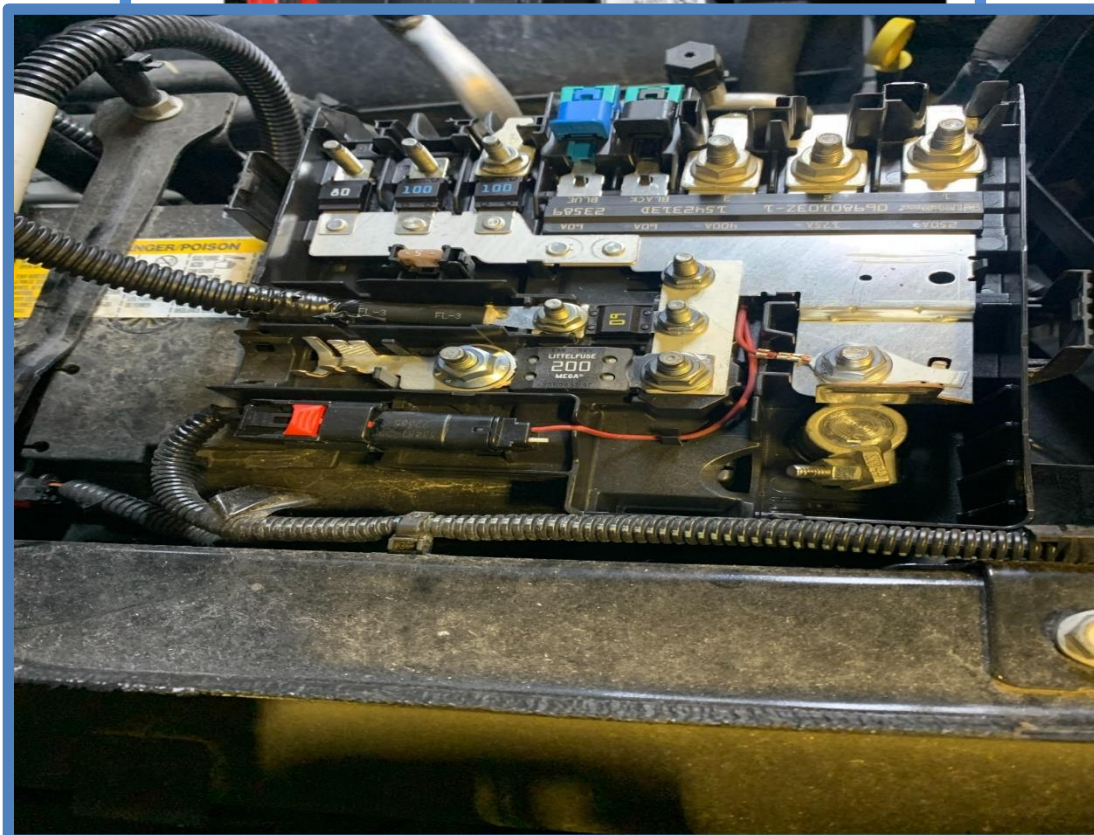
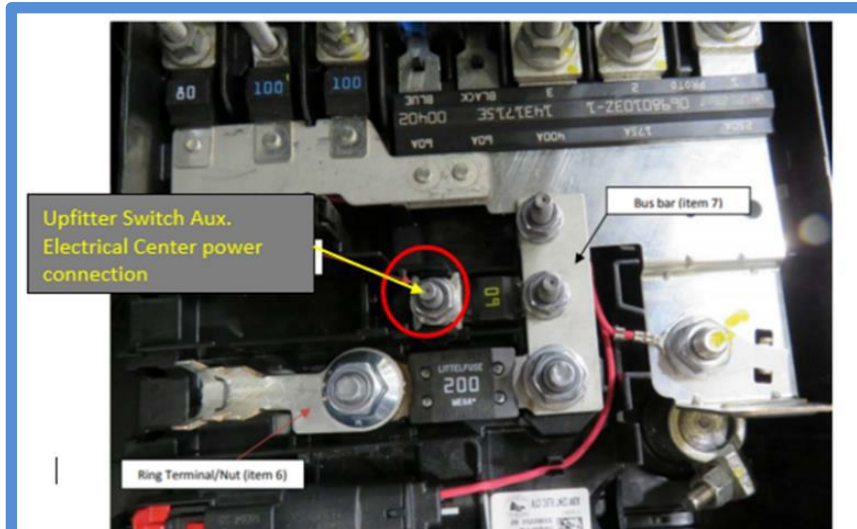

General Motors Upfitter Integration

<http://www.gmupfitter.com>

Upfitter Provisions - 1 of 2 (9L7)

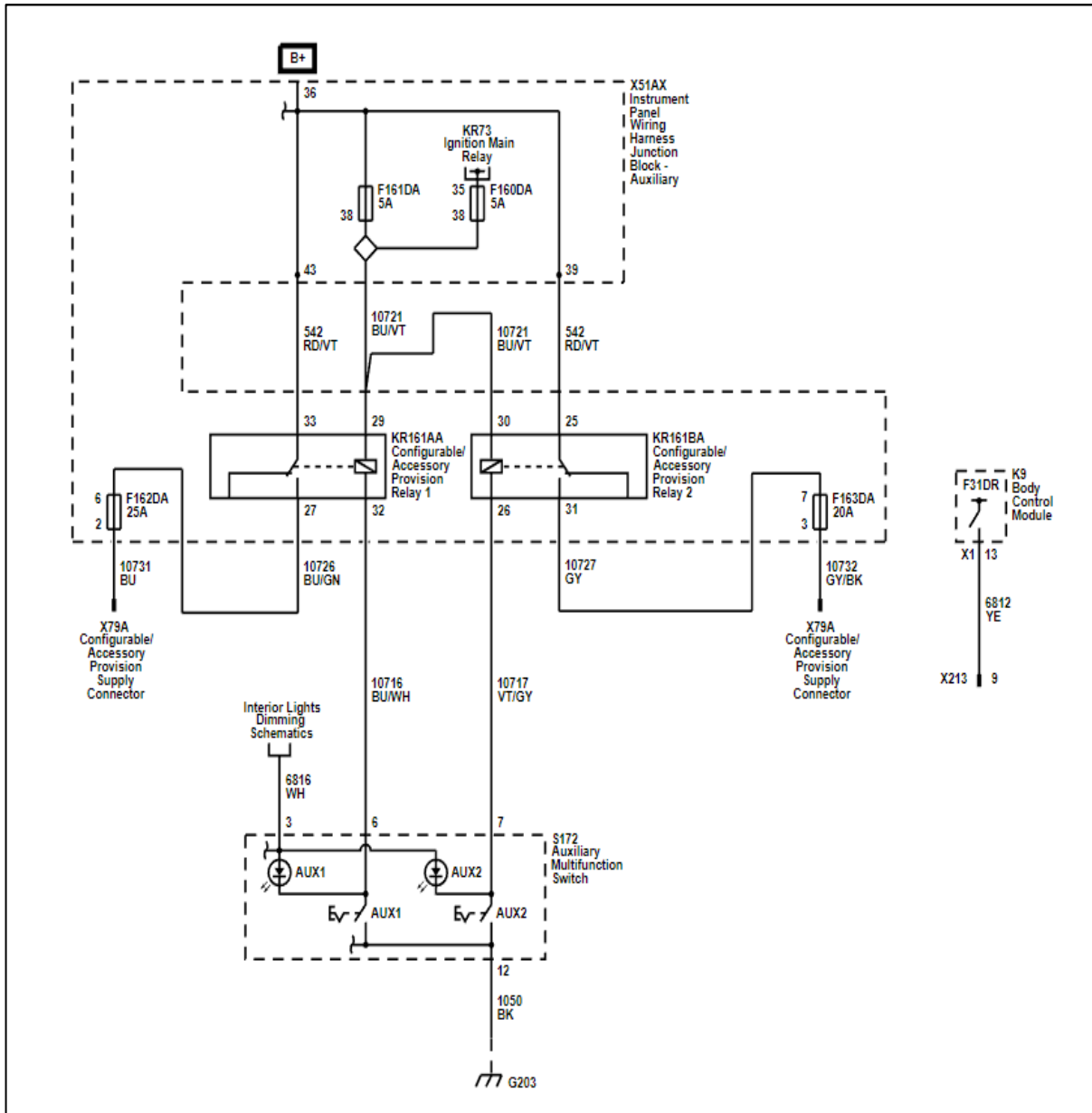

General Motors Upfitter Integration

<http://www.gmupfitter.com>



Upfitter Provisions - 2 of 2 (9L7)

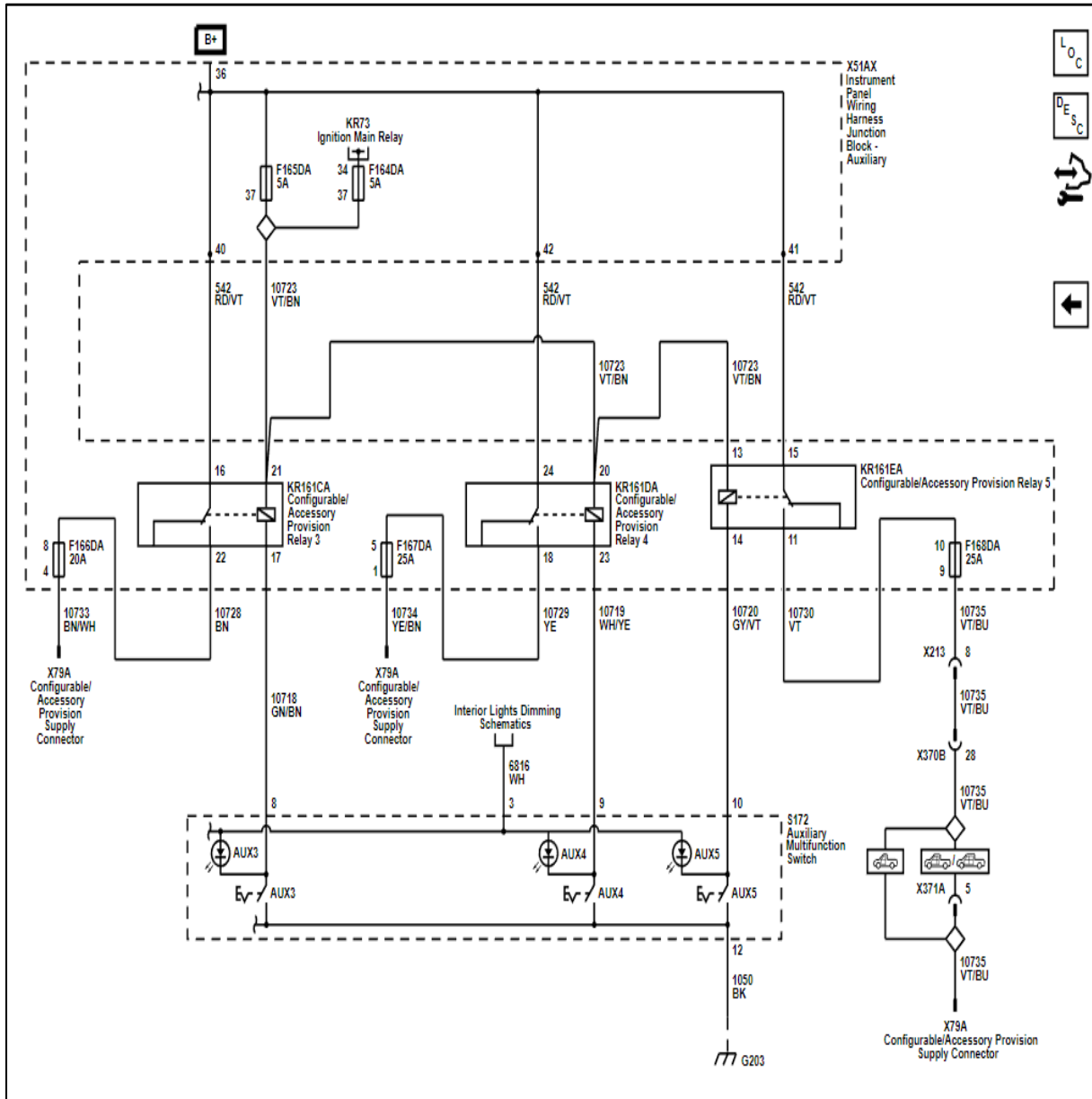

X213 Auxiliary Instrument Panel Harness to Instrument Panel Harness

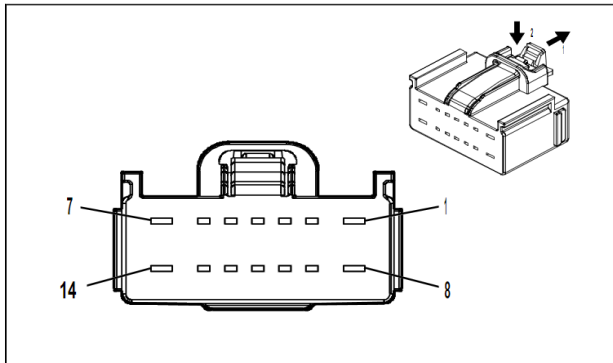

Connector Part Information

Harness Type: Auxiliary Fuse Block Wiring Harness
 OEM Connector: 33366376
 Service Connector: Service by Harness - See Part Catalog
 Description: 14-Way F 1.5, 2.8 YESC Series(GY)

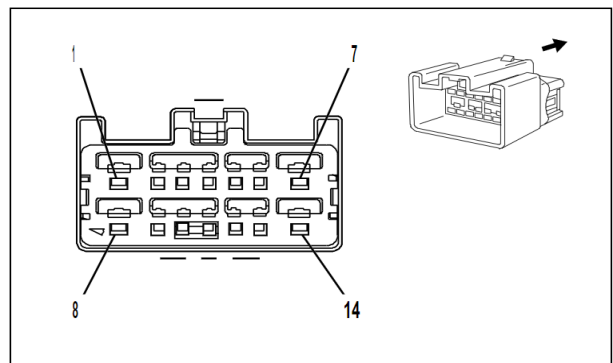

Connector Part Information

Harness Type: Instrument Panel Wiring Harness
 OEM Connector: 10846900
 Service Connector: 88956523
 Description: 14-Way M 1.5, 2.8 YESC Series(L-GY)

Terminal Part Information

Terminal Type ID	Terminated Lead	Diagnostic Test Probe	Terminal Removal Tool
I	Not required	J-35616-2A (GY)	No Tool Required
II	Not required	J-35616-4A (PU)	No Tool Required
III	13578907	J-35616-3 (GY)	J-38125-215A
IV	13578908	J-35616-5 (PU)	J-38125-11A

X213 Auxiliary Fuse Block Wiring Harness to Instrument Panel Wiring Harness (9L7)

Pin	Size	Color	Circuit	Terminal Type ID	Option	Function	Pin	Size	Color	Circuit	Terminal Type ID	Option
1	0.75	BK / WH	851	II	—	Signal Ground	1	2.5	BK	1050	IV	—
2	—	—	—	—	—	Not Occupied	2	—	—	—	—	—
3	0.35	YE	6817	I	—	LED Backlight Dimming Control 1	3	0.35	YE	6817	III	—
4	—	—	—	—	—	Not Occupied	4	—	—	—	—	—
5	0.5	WH / BU	3691	I	—	Trailer Brake Apply Signal	5	0.35	WH / BU	3691	III	—
6	—	—	—	—	—	Not Occupied	6	—	—	—	—	—
7	2.5	RD / BN	4142	II	—	Primary Fused Battery Positive Voltage	7	2.5	RD / BN	4142	IV	—
8	2.5	VT / BU	10735	II	—	Upfitter Accessory 5 Supply Voltage	8	2.5	VT / BU	10735	IV	—
9	—	—	—	—	—	Out of Park Signal	9	0.35	YE	6812	III	—
10	—	—	—	—	—	Vehicle Speed Signal	10	0.35	GN / GY	817	III	—
11	0.35	WH	6816	I	—	Indicator Dimming Control	11	0.35	WH	6816	III	—
12	—	—	—	—	—	Not Occupied	12	—	—	—	—	—
13	0.5	VT / BK	339	I	—	Run/Crank Ignition 1 Voltage	13	0.5	VT / BK	339	III	—
14	2	BU	47	II	—	Trailer Auxiliary Control	14	2	BU	47	IV	—

Additional Information:

The upfitter switches are defaulted to being battery powered but can be reconfigured in pairs to operate only when in accessory/ignition ON by relocating one or two fuses as shown below.

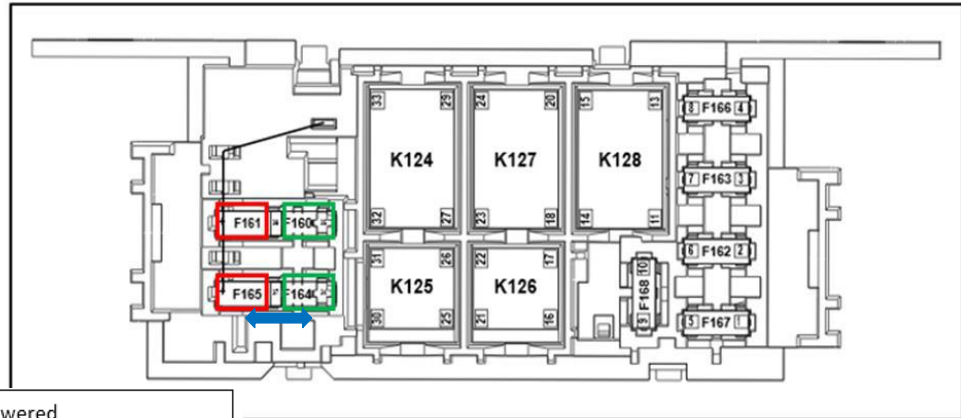

- Red = Battery Powered
 - Green = Ign. Run/Crank Powered
- Fuse Position 160/161 = Switches 1 and 2
 Fuse Position 164/165 = Switches 3 and 4