



**MY24 & BEYOND
SILVERADO MED DUTY
CONFIGURATION
DIAGRAMS C/K(56403)**

CONFIGURATION DIAGRAMS - GENERAL INFORMATION

Model:	C56403 K56403
Cab:	REGULAR CAB

CA	WB
84"	165"
108"	189"
120"	201"
138"	219"
150"	231"
162"	243"

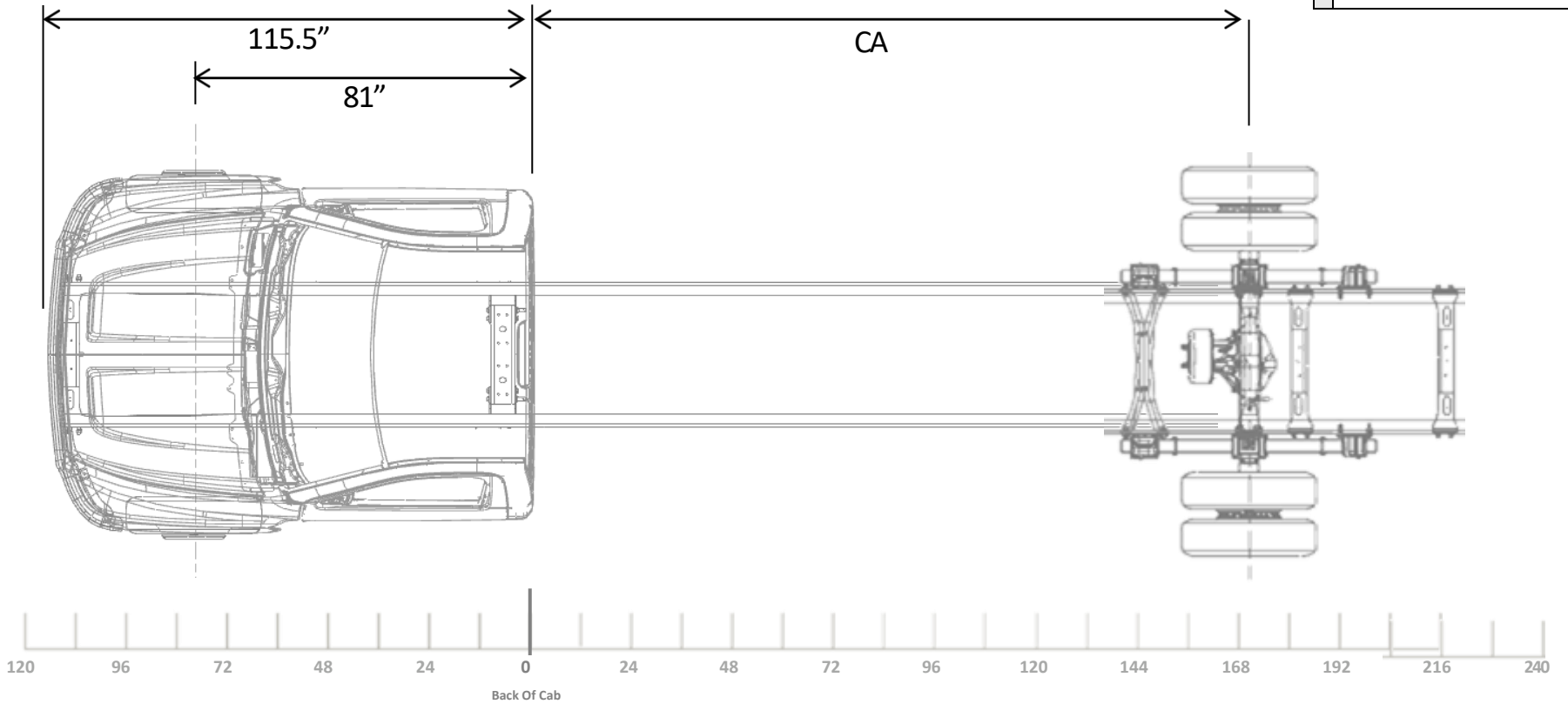

REGULAR
CAB 165"
WB

Model/Feature Information

Model:		C56403 K56403
Cab:		REGULAR CAB
Aftertreatment:		HORIZONTAL
Fuel Tank:	RPO N2L	40 GAL, AF MTD
Battery Box:	RPO 7Y7/7Y8	28" STEEL, 2 BATTERIES
Air Tanks:		(1) OUTSIDE LEFT
DEF Tank:		6.75 GAL
Engine:		6.6L GM DURAMAX

General Configuration Information

4X2 OR 4X4 TRUCK CONFIGURATION
 VARI-RATE REAR SUSPENSION

RT SIDE TAILPIPE, EXITS BEHIND
 REAR WHEEL (RPO NPR)

OPTIONAL AIR DRYER FWD OUTSIDE
 RT (RPO KUT/JPY)

Minimum Wheelbase

165" WB (84" CA)
 49" OR 63" AF

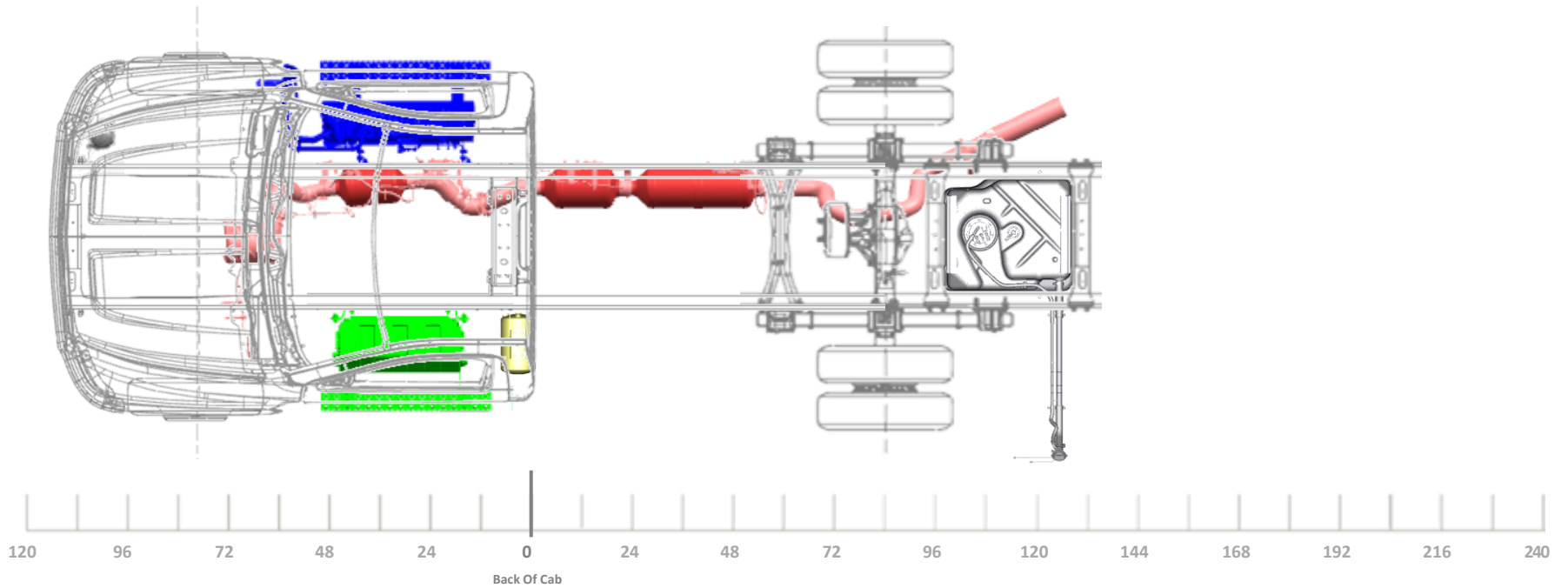

Model/Feature Information

Model:		C56403 K56403
Cab:		REGULAR CAB
Aftertreatment:		HORIZONTAL
Fuel Tank:	RPO N2L	40 GAL, AF MTD
Battery Box:	RPO 7Y9	TEMP MTD, 3 BATT
Air Tanks:		(1) OUTSIDE LEFT
DEF Tank:		6.75 GAL
Engine:		6.6L GM DURAMAX

General Configuration Information

4X2 OR 4X4 TRUCK CONFIGURATION
VARI-RATE REAR SUSPENSION
RT SIDE TAILPIPE, EXITS BEHIND REAR WHEEL (RPO NPR)
OPTIONAL AIR DRYER FWD OUTSIDE RT (RPO KUT/JPY)

Minimum Wheelbase

165" WB (84" CA)
49" OR 63" AF

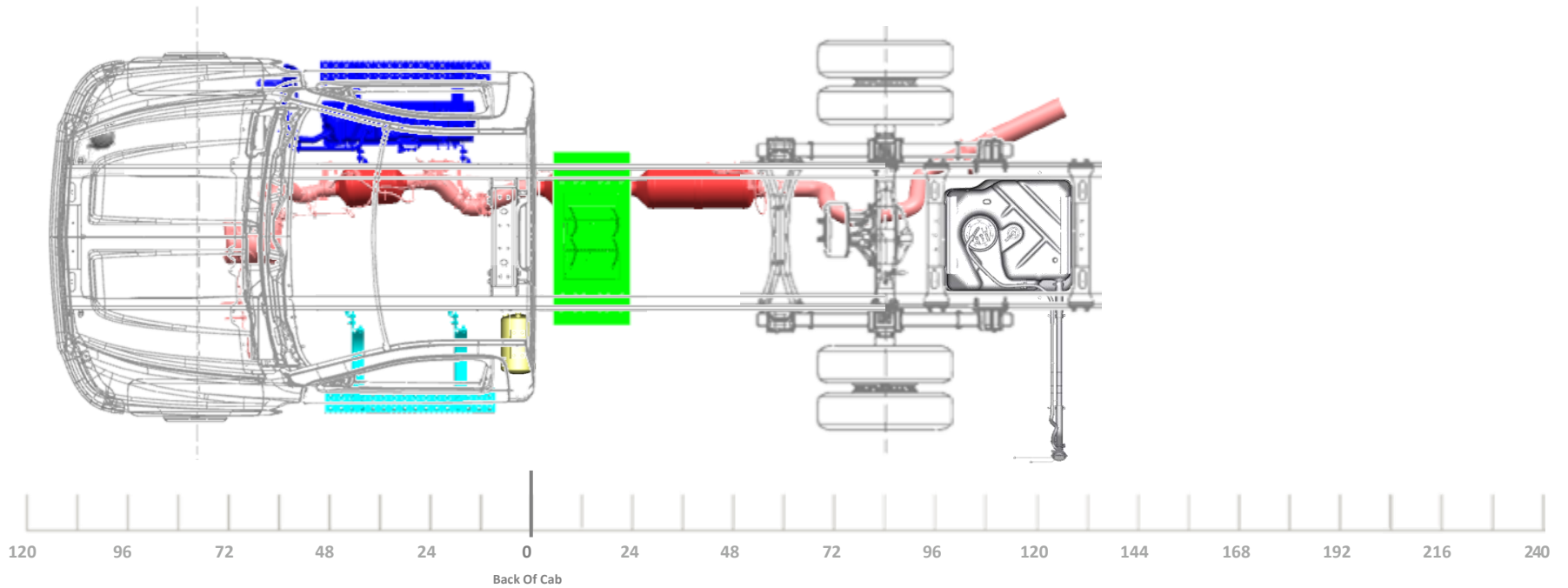

LAST REVISION: 4/25/2024

Model/Feature Information

Model:		C56403 K56403
Cab:		REGULAR CAB
Aftertreatment:		HORIZONTAL
Fuel Tank:	RPO NVK	25 GAL, CA MTD
Battery Box:	RPO 7Y7/7Y8	28" STEEL, 2 BATTERIES
Air Tanks:		(1) OUTSIDE LEFT
DEF Tank:		6.75 GAL
Engine:		6.6L GM DURAMAX

General Configuration Information

4X2 OR 4X4 TRUCK CONFIGURATION
VARI-RATE SUSPENSION
RT SIDE TAILPIPE, EXITS BEHIND REAR WHEEL (RPO NPR)
OPTIONAL AIR DRYER FWD OUTSIDE RT (RPO KUT/JPY)

Minimum Wheelbase

165" WB (84" CA)
49" OR 63" AF

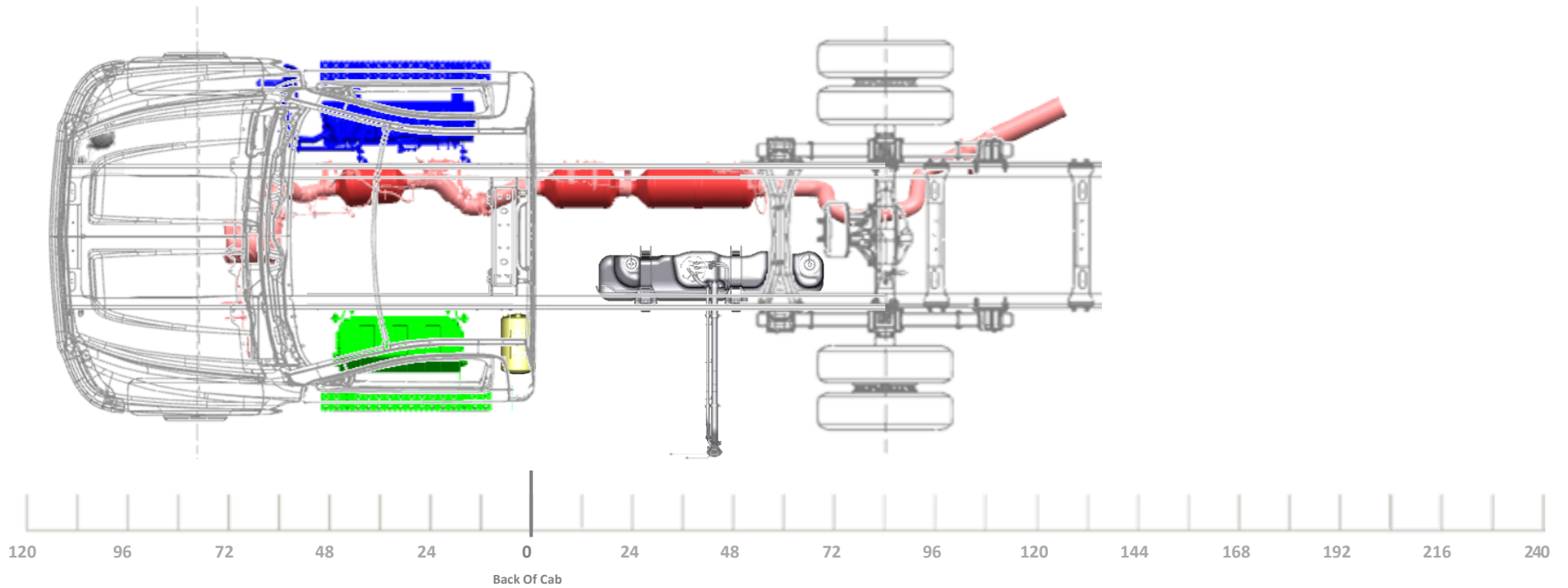

LAST REVISION: 4/25/2024

Model/Feature Information

Model:		C56403 K56403
Cab:		REGULAR CAB
Aftertreatment:		HORIZONTAL
Fuel Tank:	RPO NVK	25 GAL, CA MTD
Battery Box:	RPO 7Y9	TEMP MTD, 3 BATT
Air Tanks:		(1) OUTSIDE LEFT
DEF Tank:		6.75 GAL
Engine:		6.6L GM DURAMAX

General Configuration Information

4X2 OR 4X4 TRUCK CONFIGURATION
 VARI-RATE SUSPENSION

RT SIDE TAILPIPE, EXITS BEHIND
 REAR WHEEL (RPO NPR)

OPTIONAL AIR DRYER FWD OUTSIDE
 RT (RPO KUT/JPY)

Minimum Wheelbase

165" WB (84" CA)
 49" OR 63" AF

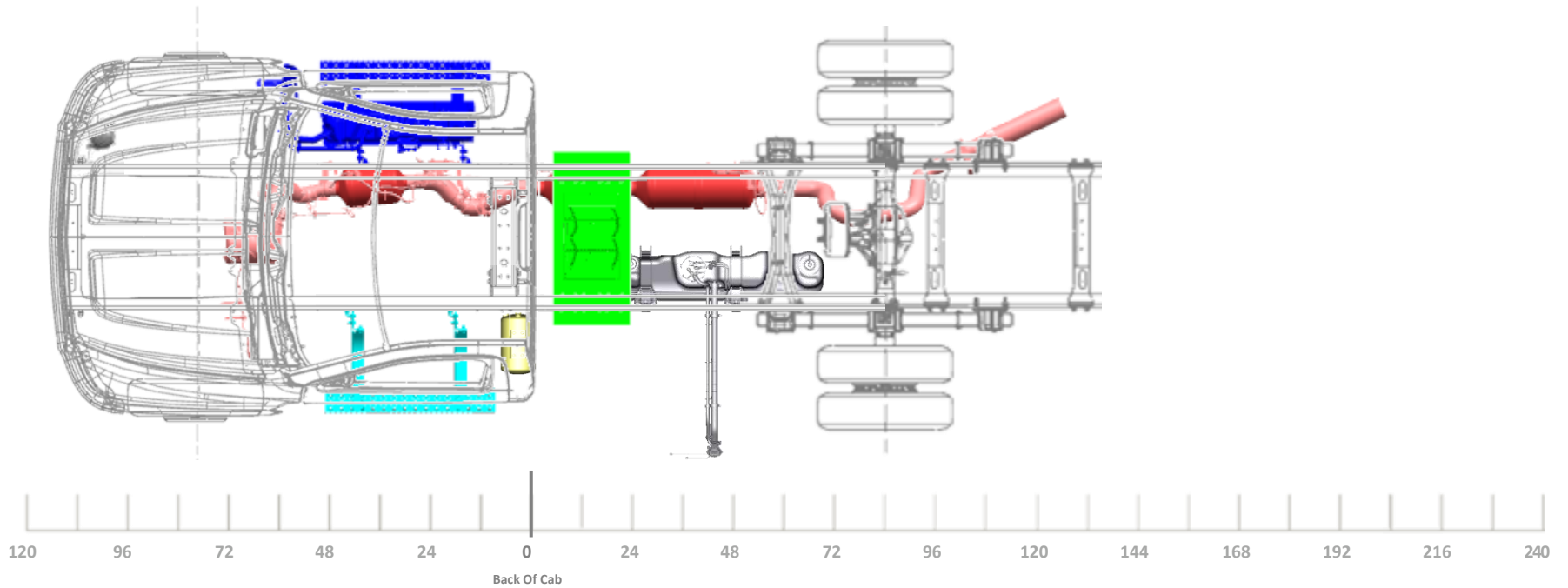

LAST REVISION: 4/25/2024

Model/Feature Information

Model:		C56403 K56403
Cab:		REGULAR CAB
Aftertreatment:		HORIZONTAL
Fuel Tank:	RPO NSQ	DUAL 25G CA, 40G AF
Battery Box:	RPO 7Y7/7Y8	28" STEEL, 2 BATTERIES
Air Tanks:		(1) OUTSIDE LEFT
DEF Tank:		6.75 GAL
Engine:		6.6L GM DURAMAX

General Configuration Information

4X2 OR 4X4 TRUCK CONFIGURATION
VARI-RATE REAR SUSPENSION
RT SIDE TAILPIPE, EXITS BEHIND REAR WHEEL (RPO NPR)
OPTIONAL AIR DRYER FWD OUTSIDE RT (RPO KUT/JPY)

Minimum Wheelbase

165" WB (84" CA)
49" OR 63" AF

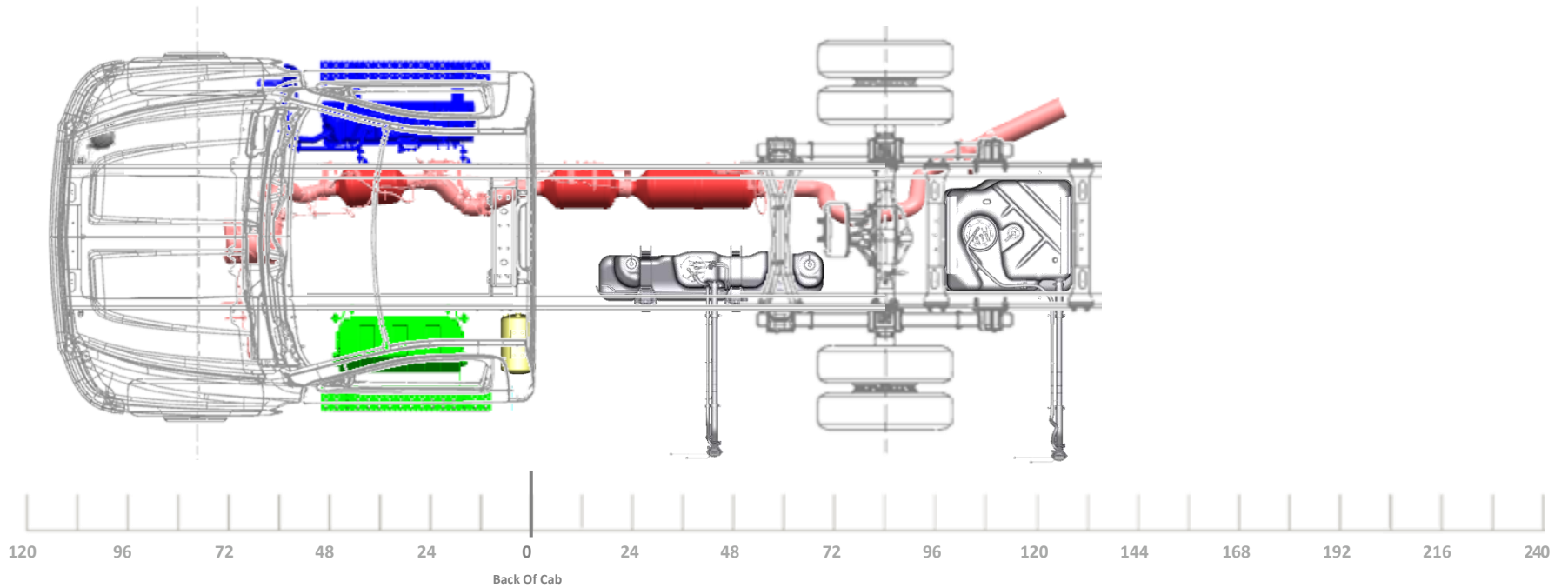

LAST REVISION: 4/25/2024

Model/Feature Information

Model:		C56403 K56403
Cab:		REGULAR CAB
Aftertreatment:		HORIZONTAL
Fuel Tank:	RPO NSQ	DUAL 25G CA, 40G AF
Battery Box:	RPO 7Y9	TEMP MTD, 3 BATT
Air Tanks:		(1) OUTSIDE LEFT
DEF Tank:		6.75 GAL
Engine:		6.6L GM DURAMAX

General Configuration Information

4X2 OR 4X4 TRUCK CONFIGURATION
 VARI-RATE REAR SUSPENSION

RT SIDE TAILPIPE, EXITS BEHIND
 REAR WHEEL (RPO NPR)

OPTIONAL AIR DRYER FWD OUTSIDE
 RT (RPO KUT/JPY)

Minimum Wheelbase

165" WB (84" CA)
 49" OR 63" AF

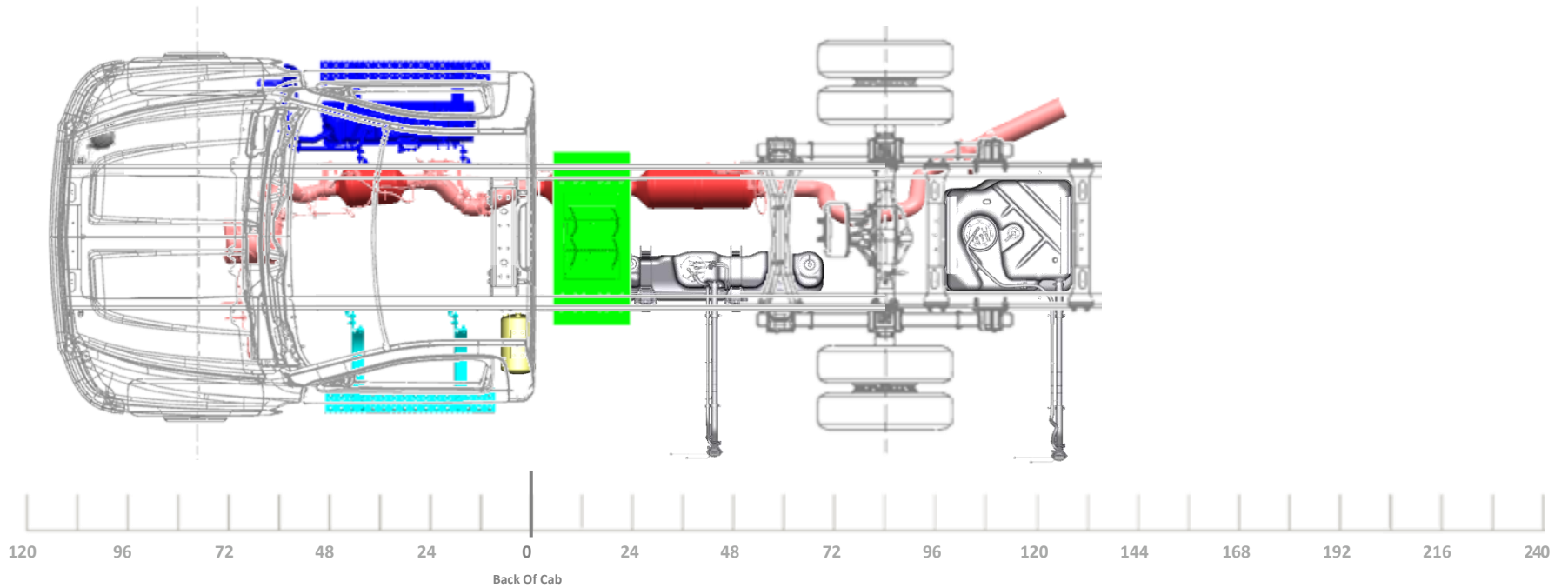

LAST REVISION: 4/25/2024

REGULAR
CAB 189"
WB

Model/Feature Information

Model:		C56403 K56403
Cab:		REGULAR CAB
Aftertreatment:		HORIZONTAL
Fuel Tank:	RPO N2L	40 GAL, AF MTD
Battery Box:	RPO 7Y7/7Y8	28" STEEL, 2 BATTERIES
Air Tanks:		(1) OUTSIDE LEFT
DEF Tank:		6.75 GAL
Engine:		6.6L GM DURAMAX

General Configuration Information

4X2 OR 4X4 TRUCK CONFIGURATION
 VARI-RATE REAR SUSPENSION

STRAIGHT TAILPIPE (RPO N12)

OPTIONAL AIR DRYER FWD OUTSIDE
 RT (RPO KUT/JPY)

Minimum Wheelbase

189" WB (108" CA)
 49", 63", OR 75" AF

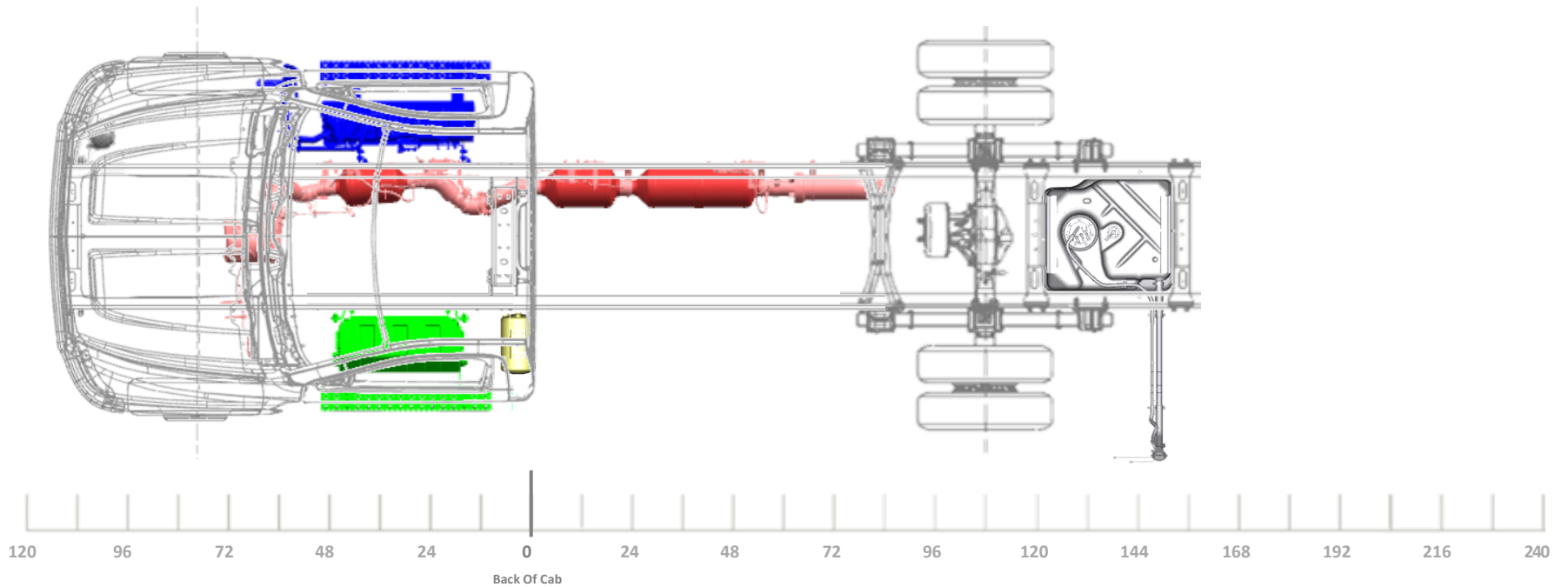

LAST REVISION: 9/25/2023

Model/Feature Information

Model:		C56403 K56403
Cab:		REGULAR CAB
Aftertreatment:		HORIZONTAL
Fuel Tank:	RPO N2L	40 GAL, AF MTD
Battery Box:	RPO 7Y7/7Y8	28" STEEL, 2 BATTERIES
Air Tanks:		(1) OUTSIDE LEFT
DEF Tank:		6.75 GAL
Engine:		6.6L GM DURAMAX

General Configuration Information

4X2 TRUCK CONFIGURATION
REAR AIR SUSPENSION
STRAIGHT TAILPIPE (RPO N12)
OPTIONAL AIR DRYER FWD OUTSIDE RT (RPO KUT/JPY)

Minimum Wheelbase

189" WB (108" CA)
63" OR 75" AF

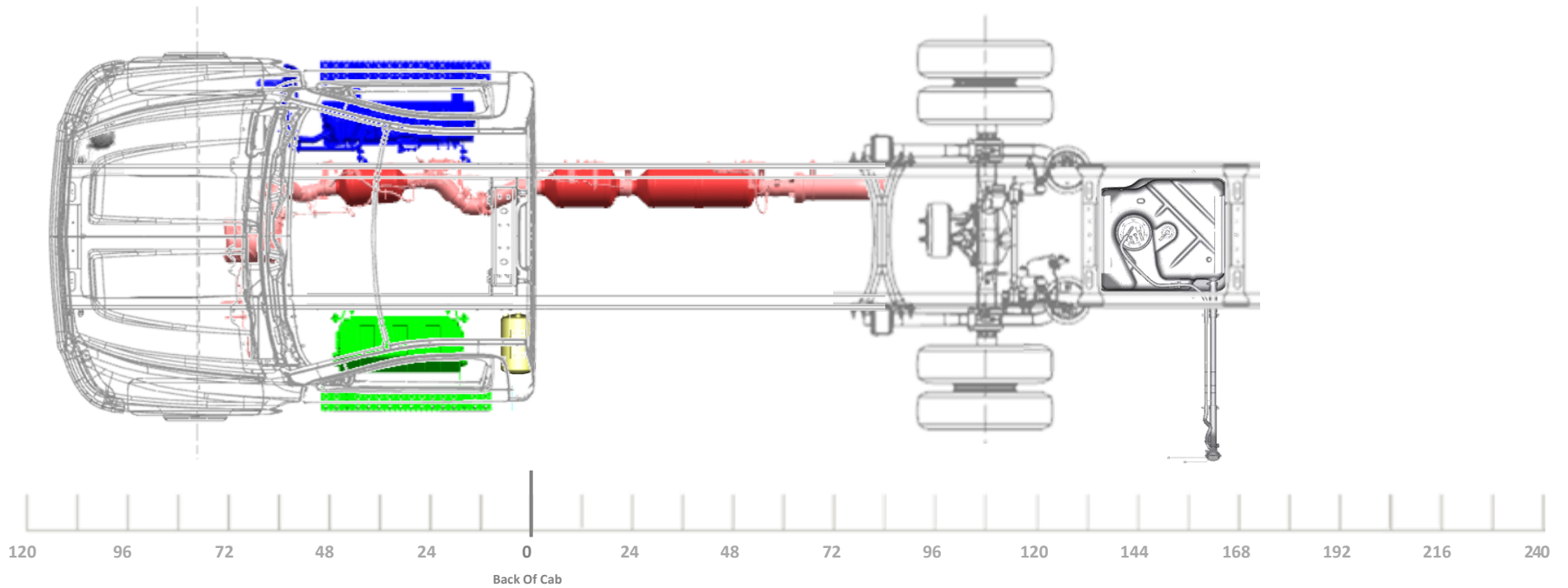

LAST REVISION: 9/25/2023

Model/Feature Information

Model:		C56403 K56403
Cab:		REGULAR CAB
Aftertreatment:		HORIZONTAL
Fuel Tank:	RPO N2L	40 GAL, AF MTD
Battery Box:	RPO 7Y9	TEMP MTD, 3 BATT
Air Tanks:		(1) OUTSIDE LEFT
DEF Tank:		6.75 GAL
Engine:		6.6L GM DURAMAX

General Configuration Information

4X2 OR 4X4 TRUCK CONFIGURATION
 VARI-RATE REAR SUSPENSION

STRAIGHT TAILPIPE (RPO N12)

OPTIONAL AIR DRYER FWD OUTSIDE
 RT (RPO KUT/JPY)

Minimum Wheelbase

189" WB (108" CA)
 49", 63", OR 75" AF

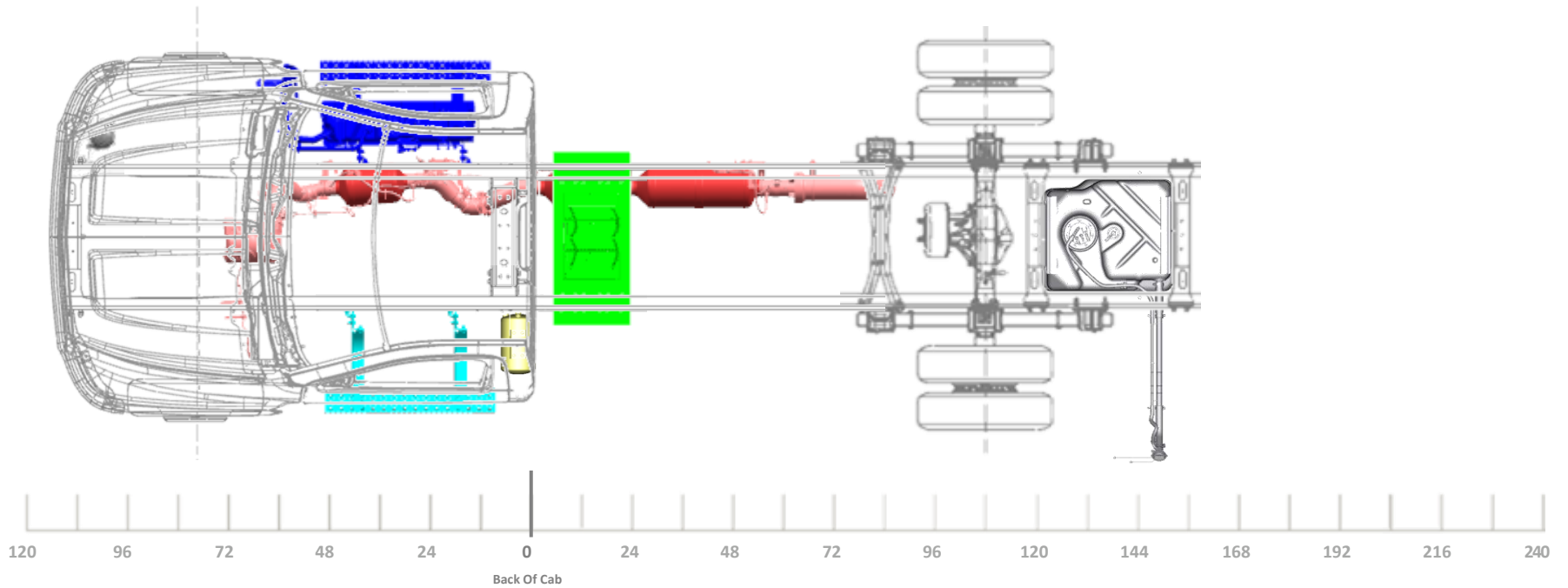

LAST REVISION: 9/25/2023

Model/Feature Information

Model:		C56403 K56403
Cab:		REGULAR CAB
Aftertreatment:		HORIZONTAL
Fuel Tank:	RPO N2L	40 GAL, AF MTD
Battery Box:	RPO 7Y9	TEMP MTD, 3 BATT
Air Tanks:		(1) OUTSIDE LEFT
DEF Tank:		6.75 GAL
Engine:		6.6L GM DURAMAX

General Configuration Information

4X2 TRUCK CONFIGURATION
REAR AIR SUSPENSION
STRAIGHT TAILPIPE (RPO N12)
OPTIONAL AIR DRYER FWD OUTSIDE RT (RPO KUT/JPY)

Minimum Wheelbase

189" WB (108" CA)
63" OR 75" AF

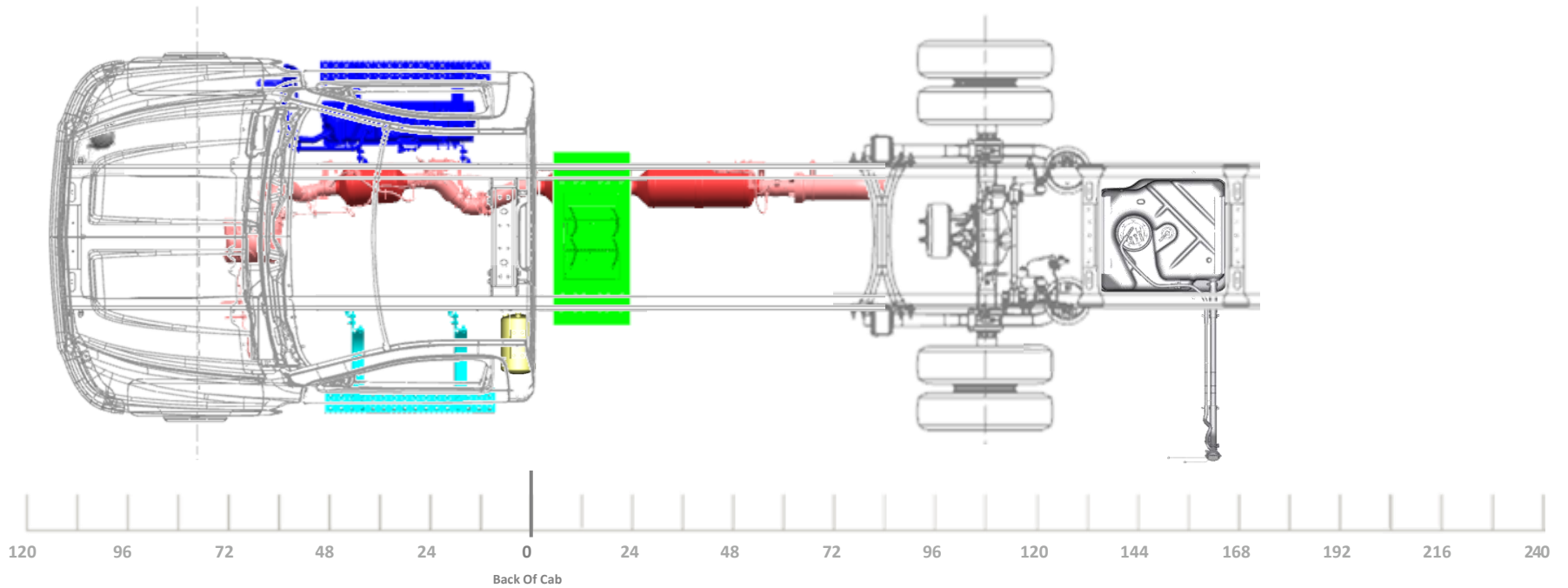

LAST REVISION: 9/25/2023

Model/Feature Information

Model:		C56403 K56403
Cab:		REGULAR CAB
Aftertreatment:		HORIZONTAL
Fuel Tank:	RPO N2L	40 GAL, AF MTD
Battery Box:	RPO 7Y7/7Y8	28" STEEL, 2 BATTERIES
Air Tanks:		(1) OUTSIDE LEFT
DEF Tank:		6.75 GAL
Engine:		6.6L GM DURAMAX

General Configuration Information

4X2 OR 4X4 TRUCK CONFIGURATION
VARI-RATE REAR SUSPENSION

SIDE EXIT TAILPIPE AHEAD OF REAR
WHEELS, LT SIDE (RPO NPJ)

OPTIONAL AIR DRYER FWD OUTSIDE
RT (RPO KUT/JPY)

Minimum Wheelbase

189" WB (108" CA)
49", 63", OR 75" AF

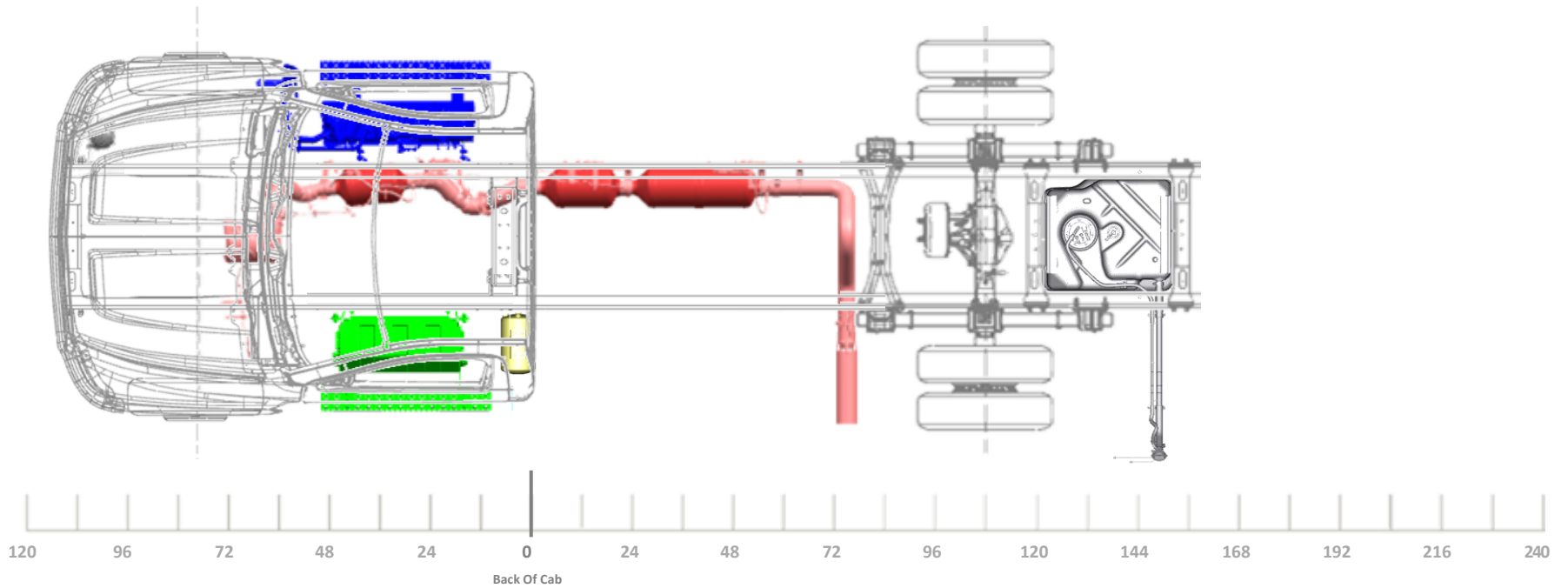

LAST REVISION: 9/25/2023

Model/Feature Information

Model:		C56403 K56403
Cab:		REGULAR CAB
Aftertreatment:		HORIZONTAL
Fuel Tank:	RPO N2L	40 GAL, AF MTD
Battery Box:	RPO 7Y7/7Y8	28" STEEL, 2 BATTERIES
Air Tanks:		(1) OUTSIDE LEFT
DEF Tank:		6.75 GAL
Engine:		6.6L GM DURAMAX

General Configuration Information

4X2 TRUCK CONFIGURATION
REAR AIR SUSPENSION
SIDE EXIT TAILPIPE AHEAD OF REAR WHEELS, LT SIDE (RPO NPJ)
OPTIONAL AIR DRYER FWD OUTSIDE RT (RPO KUT/JPY)

Minimum Wheelbase

189" WB (108" CA)
63" OR 75" AF

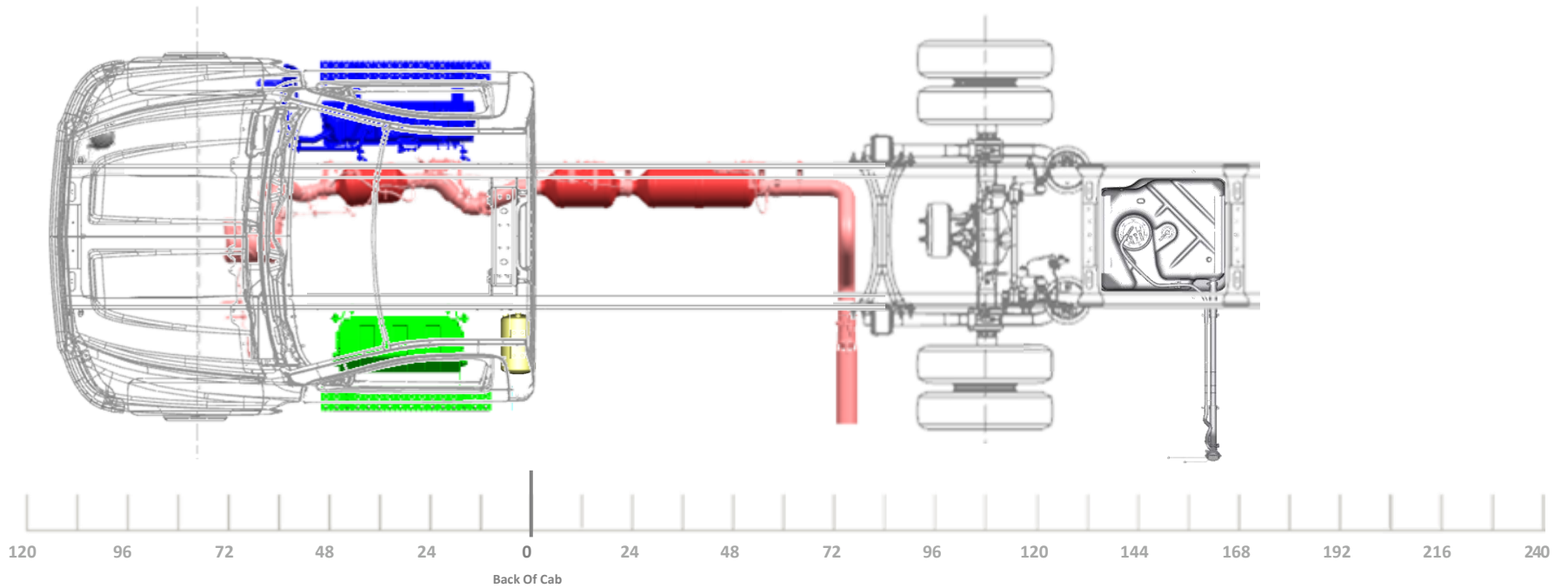

LAST REVISION: 9/25/2023

Model/Feature Information

Model:		C56403 K56403
Cab:		REGULAR CAB
Aftertreatment:		HORIZONTAL
Fuel Tank:	RPO N2L	40 GAL, AF MTD
Battery Box:	RPO 7Y9	TEMP MTD, 3 BATT
Air Tanks:		(1) OUTSIDE LEFT
DEF Tank:		6.75 GAL
Engine:		6.6L GM DURAMAX

General Configuration Information

4X2 OR 4X4 TRUCK CONFIGURATION
VARI-RATE REAR SUSPENSION

SIDE EXIT TAILPIPE AHEAD OF REAR
WHEELS, LT SIDE (RPO NPJ)

OPTIONAL AIR DRYER FWD OUTSIDE
RT (RPO KUT/JPY)

Minimum Wheelbase

189" WB (108" CA)
49", 63", OR 75" AF

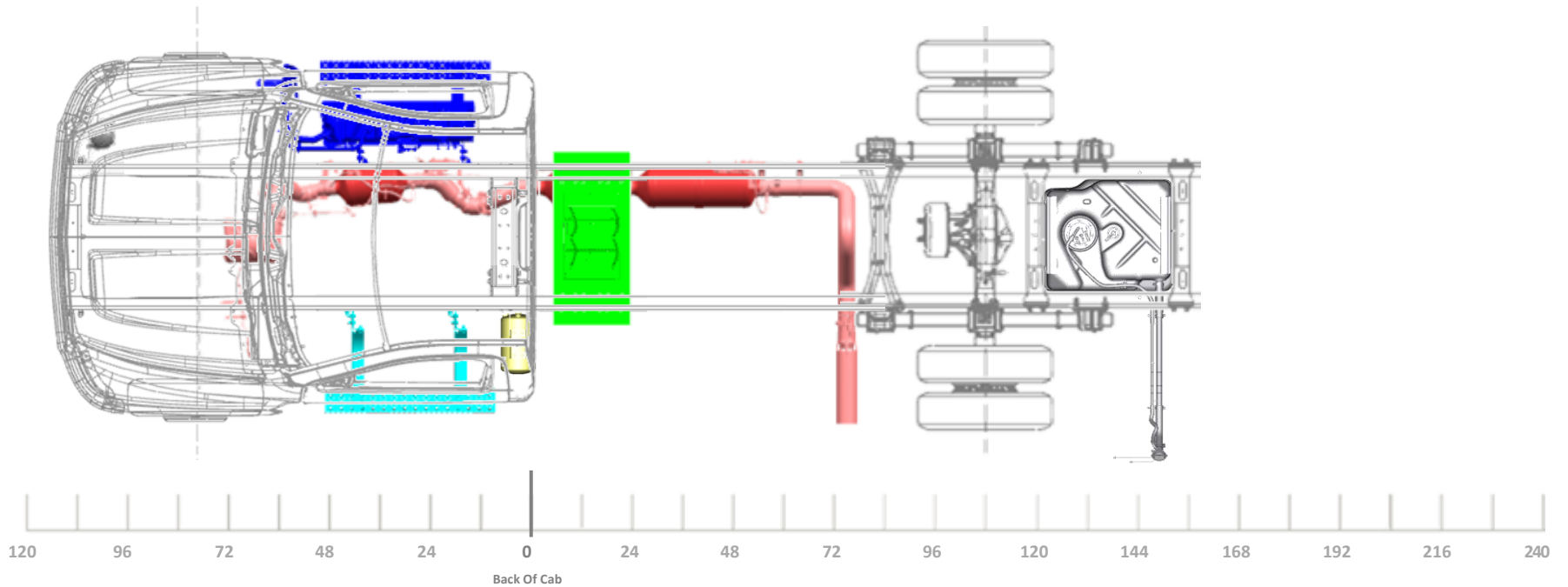

LAST REVISION: 9/25/2023

Model/Feature Information

Model:		C56403 K56403
Cab:		REGULAR CAB
Aftertreatment:		HORIZONTAL
Fuel Tank:	RPO N2L	40 GAL, AF MTD
Battery Box:	RPO 7Y9	TEMP MTD, 3 BATT
Air Tanks:		(1) OUTSIDE LEFT
DEF Tank:		6.75 GAL
Engine:		6.6L GM DURAMAX

General Configuration Information

4X2 TRUCK CONFIGURATION
REAR AIR SUSPENSION
SIDE EXIT TAILPIPE AHEAD OF REAR WHEELS, LT SIDE (RPO NPJ)
OPTIONAL AIR DRYER FWD OUTSIDE RT (RPO KUT/JPY)

Minimum Wheelbase

189" WB (108" CA)
63" OR 75" AF

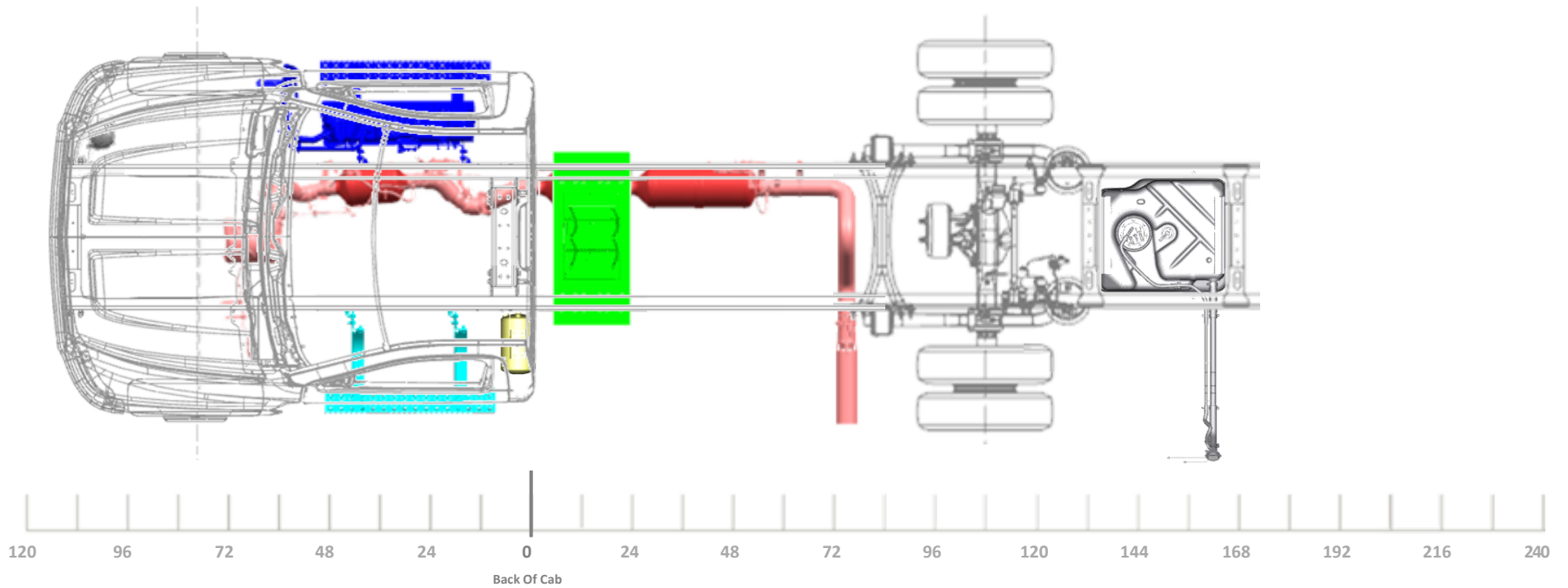

LAST REVISION: 9/25/2023

Model/Feature Information

Model:		C56403 K56403
Cab:		REGULAR CAB
Aftertreatment:		HORIZONTAL
Fuel Tank:	RPO N2L	40 GAL, AF MTD
Battery Box:	RPO 7Y7/7Y8	28" STEEL, 2 BATTERIES
Air Tanks:		(1) OUTSIDE LEFT
DEF Tank:		6.75 GAL
Engine:		6.6L GM DURAMAX

General Configuration Information

4X2 OR 4X4 TRUCK CONFIGURATION
 VARI-RATE REAR SUSPENSION

SIDE EXIT TAILPIPE AHEAD OF REAR
 WHEELS, RT SIDE (RPO NPK)

OPTIONAL AIR DRYER FWD OUTSIDE
 RT (RPO KUT/JPY)

Minimum Wheelbase

189" WB (108" CA)
 49", 63", OR 75" AF

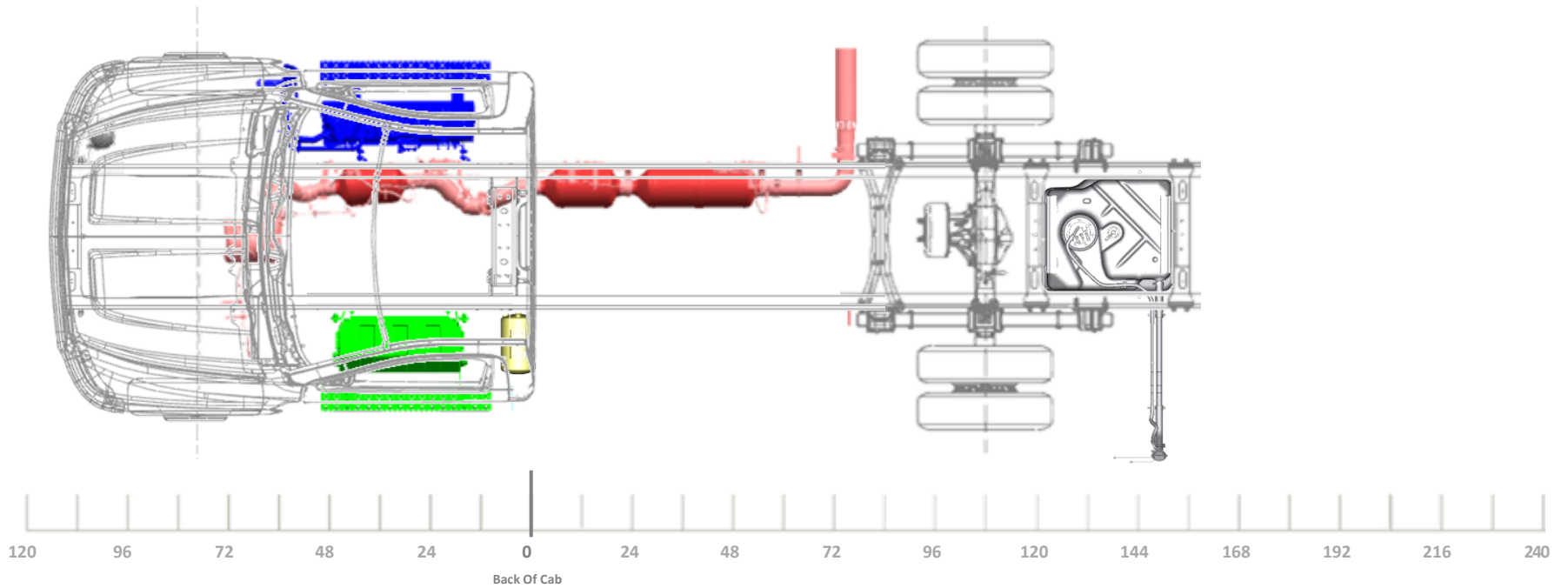

LAST REVISION: 9/25/2023

Model/Feature Information

Model:		C56403 K56403
Cab:		REGULAR CAB
Aftertreatment:		HORIZONTAL
Fuel Tank:	RPO N2L	40 GAL, AF MTD
Battery Box:	RPO 7Y7/7Y8	28" STEEL, 2 BATTERIES
Air Tanks:		(1) OUTSIDE LEFT
DEF Tank:		6.75 GAL
Engine:		6.6L GM DURAMAX

General Configuration Information

4X2 TRUCK CONFIGURATION
REAR AIR SUSPENSION
SIDE EXIT TAILPIPE AHEAD OF REAR WHEELS, RT SIDE (RPO NPK)
OPTIONAL AIR DRYER FWD OUTSIDE RT (RPO KUT/JPY)

Minimum Wheelbase

189" WB (108" CA)
63" OR 75" AF

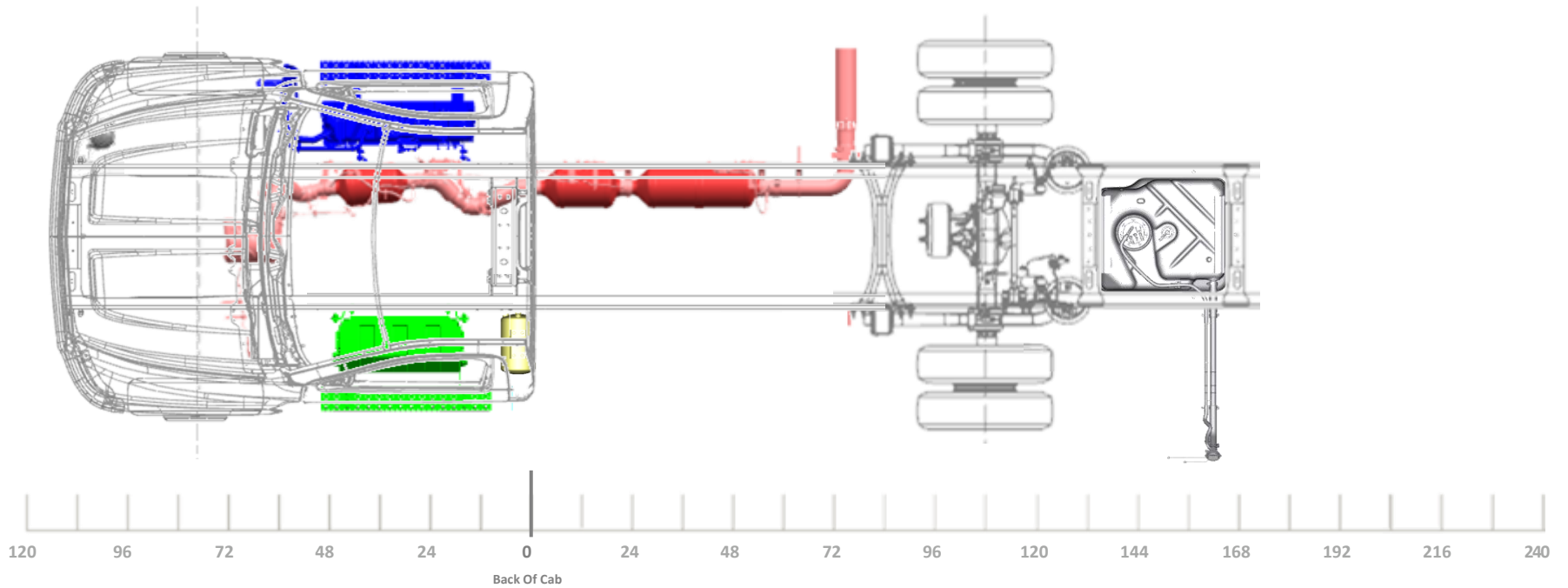

LAST REVISION: 9/25/2023

Model/Feature Information

Model:		C56403 K56403
Cab:		REGULAR CAB
Aftertreatment:		HORIZONTAL
Fuel Tank:	RPO N2L	40 GAL, AF MTD
Battery Box:	RPO 7Y9	TEMP MTD, 3 BATT
Air Tanks:		(1) OUTSIDE LEFT
DEF Tank:		6.75 GAL
Engine:		6.6L GM DURAMAX

General Configuration Information

4X2 OR 4X4 TRUCK CONFIGURATION
 VARI-RATE REAR SUSPENSION

SIDE EXIT TAILPIPE AHEAD OF REAR WHEELS, RT SIDE (RPO NPK)

OPTIONAL AIR DRYER FWD OUTSIDE RT (RPO KUT/JPY)

Minimum Wheelbase

189" WB (108" CA)
 49", 63", OR 75" AF

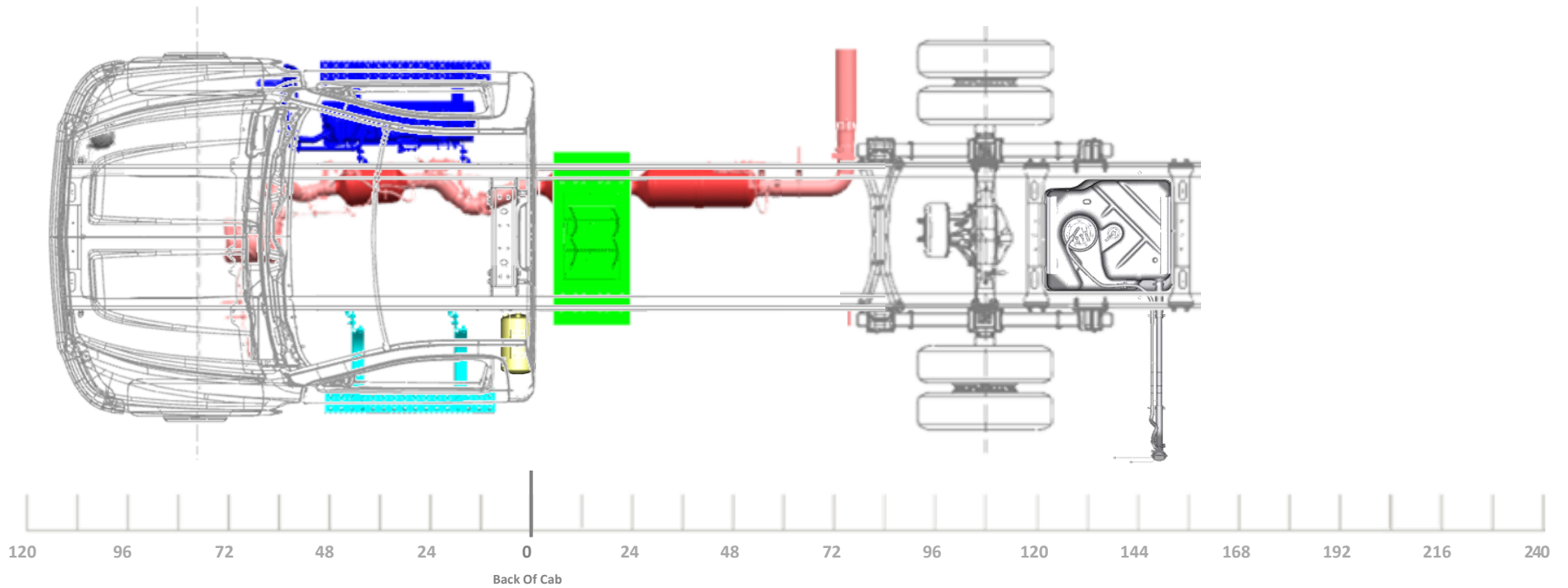

LAST REVISION: 9/25/2023

Model/Feature Information

Model:		C56403 K56403
Cab:		REGULAR CAB
Aftertreatment:		HORIZONTAL
Fuel Tank:	RPO N2L	40 GAL, AF MTD
Battery Box:	RPO 7Y9	TEMP MTD, 3 BATT
Air Tanks:		(1) OUTSIDE LEFT
DEF Tank:		6.75 GAL
Engine:		6.6L GM DURAMAX

General Configuration Information

4X2 TRUCK CONFIGURATION
REAR AIR SUSPENSION
SIDE EXIT TAILPIPE AHEAD OF REAR WHEELS, RT SIDE (RPO NPK)
OPTIONAL AIR DRYER FWD OUTSIDE RT (RPO KUT/JPY)

Minimum Wheelbase

189" WB (108" CA)
63" OR 75" AF

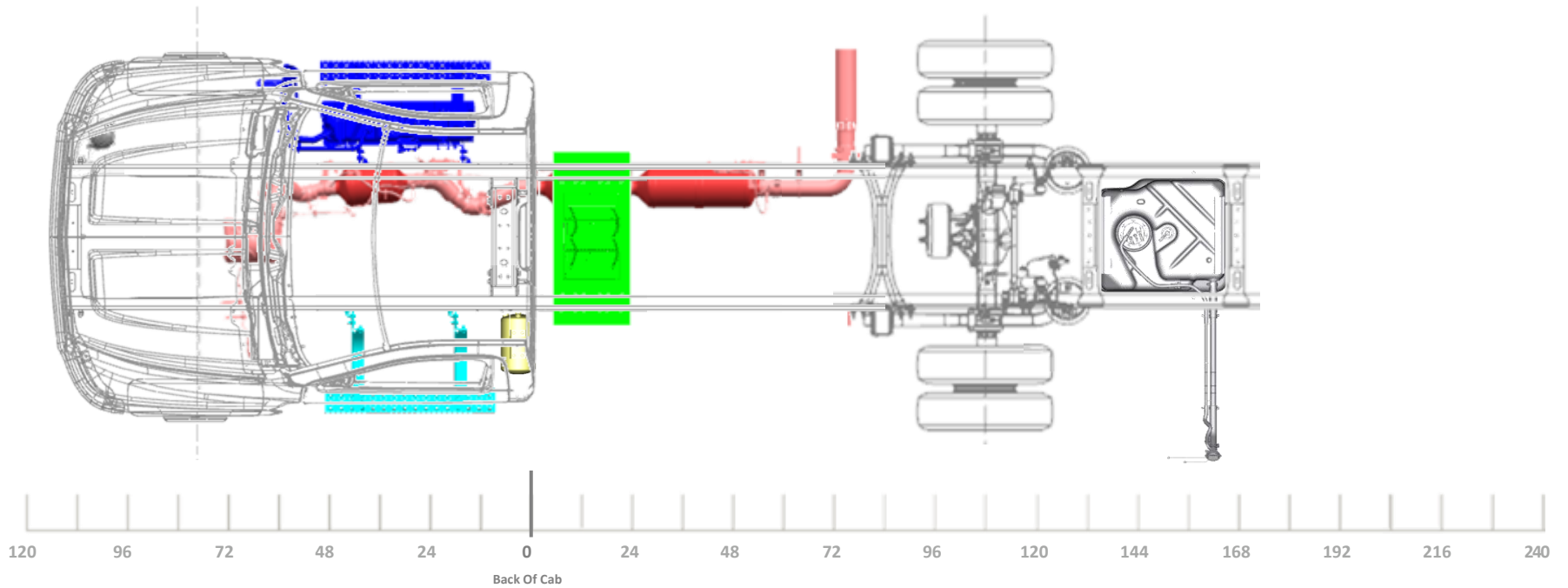

LAST REVISION: 9/25/2023

Model/Feature Information

Model:		C56403 K56403
Cab:		REGULAR CAB
Aftertreatment:		HORIZONTAL
Fuel Tank:	RPO NVK	25 GAL, CA MTD
Battery Box:	RPO 7Y7/7Y8	28" STEEL, 2 BATTERIES
Air Tanks:		(1) OUTSIDE LEFT
DEF Tank:		6.75 GAL
Engine:		6.6L GM DURAMAX

General Configuration Information

4X2 OR 4X4 TRUCK CONFIGURATION
 VARI-RATE REAR SUSPENSION

STRAIGHT TAILPIPE (RPO N12)

OPTIONAL AIR DRYER FWD OUTSIDE
 RT (RPO KUT/JPY)

Minimum Wheelbase

189" WB (108" CA)
 49", 63", OR 75" AF

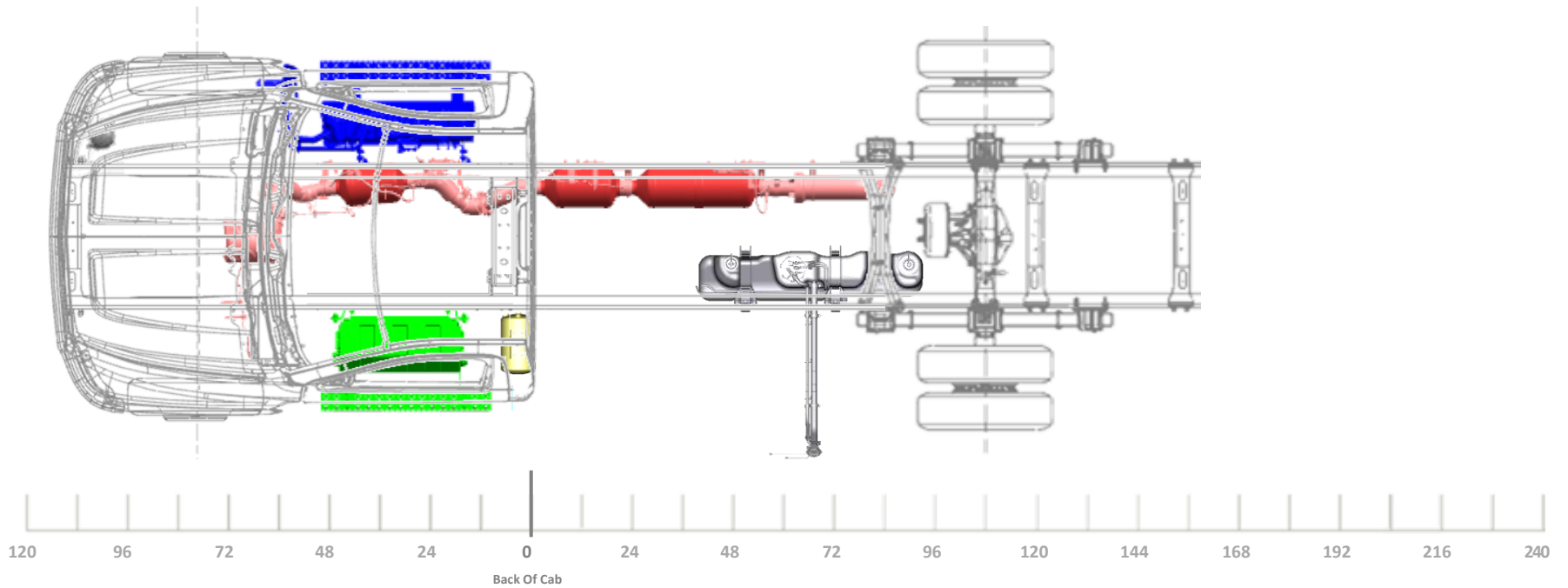

LAST REVISION: 9/25/2023

Model/Feature Information

Model:		C56403 K56403
Cab:		REGULAR CAB
Aftertreatment:		HORIZONTAL
Fuel Tank:	RPO NVK	25 GAL, CA MTD
Battery Box:	RPO 7Y7/7Y8	28" STEEL, 2 BATTERIES
Air Tanks:		(1) OUTSIDE LEFT
DEF Tank:		6.75 GAL
Engine:		6.6L GM DURAMAX

General Configuration Information

4X2 TRUCK CONFIGURATION
REAR AIR SUSPENSION
STRAIGHT TAILPIPE (RPO N12)
OPTIONAL AIR DRYER FWD OUTSIDE RT (RPO KUT/JPY)

Minimum Wheelbase

189" WB (108" CA)
63" OR 75" AF

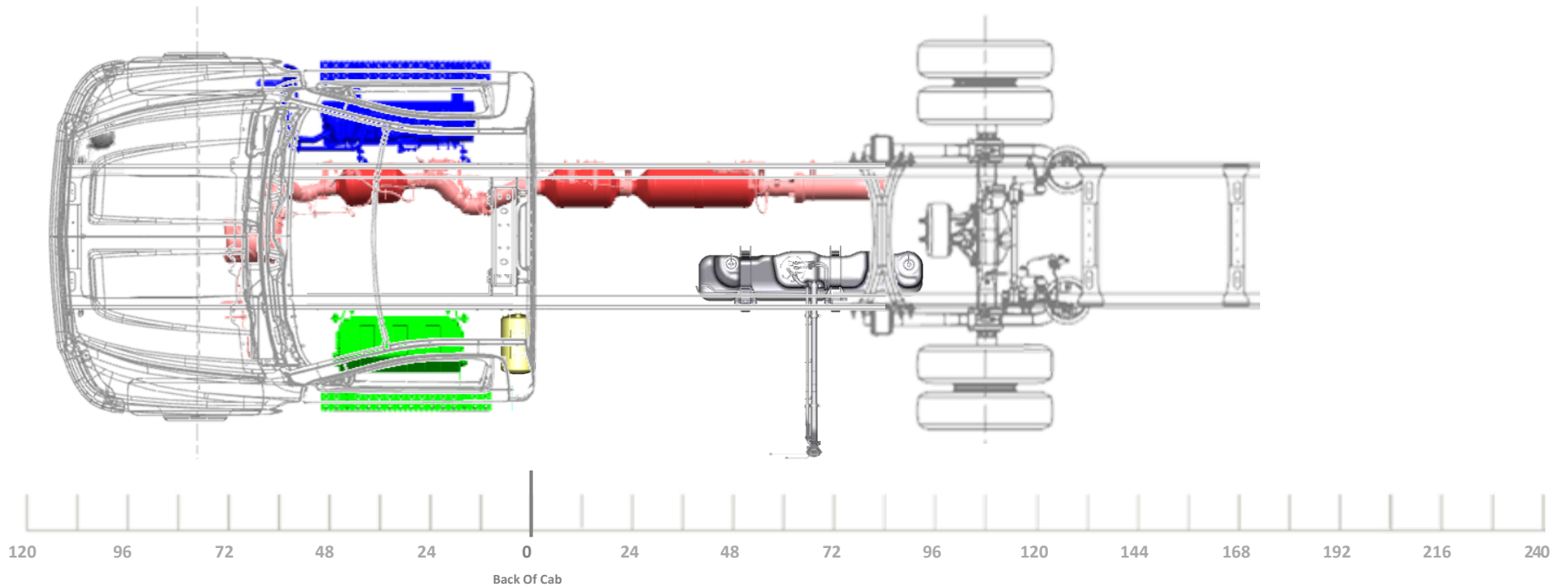

LAST REVISION: 9/25/2023

Model/Feature Information

Model:		C56403 K56403
Cab:		REGULAR CAB
Aftertreatment:		HORIZONTAL
Fuel Tank:	RPO NVK	25 GAL, CA MTD
Battery Box:	RPO 7Y9	TEMP MTD, 3 BATT
Air Tanks:		(1) OUTSIDE LEFT
DEF Tank:		6.75 GAL
Engine:		6.6L GM DURAMAX

General Configuration Information

4X2 OR 4X4 TRUCK CONFIGURATION
 VARI-RATE REAR SUSPENSION

STRAIGHT TAILPIPE (RPO N12)

OPTIONAL AIR DRYER FWD OUTSIDE
 RT (RPO KUT/JPY)

Minimum Wheelbase

189" WB (108" CA)
 49", 63", OR 75" AF

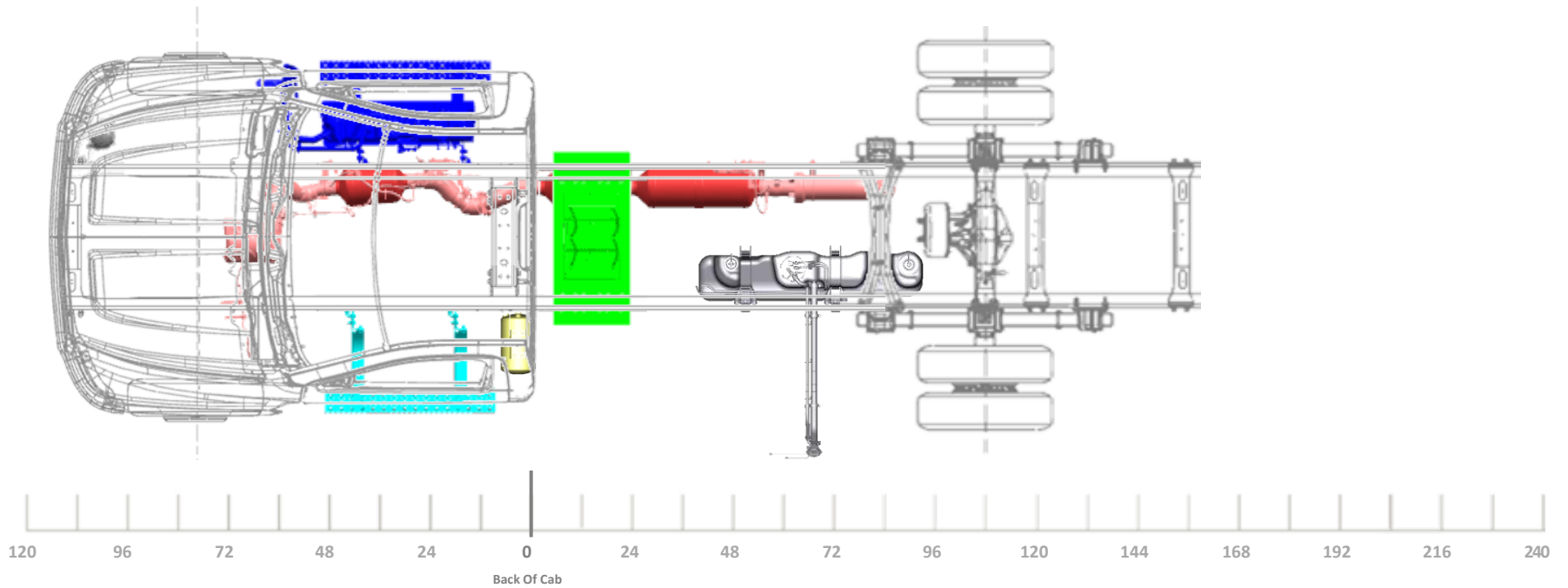

LAST REVISION: 9/25/2023

Model/Feature Information

Model:		C56403 K56403
Cab:		REGULAR CAB
Aftertreatment:		HORIZONTAL
Fuel Tank:	RPO NVK	25 GAL, CA MTD
Battery Box:	RPO 7Y9	TEMP MTD, 3 BATT
Air Tanks:		(1) OUTSIDE LEFT
DEF Tank:		6.75 GAL
Engine:		6.6L GM DURAMAX

General Configuration Information

4X2 TRUCK CONFIGURATION
REAR AIR SUSPENSION
STRAIGHT TAILPIPE (RPO N12)
OPTIONAL AIR DRYER FWD OUTSIDE RT (RPO KUT/JPY)

Minimum Wheelbase

189" WB (108" CA)
63" OR 75" AF

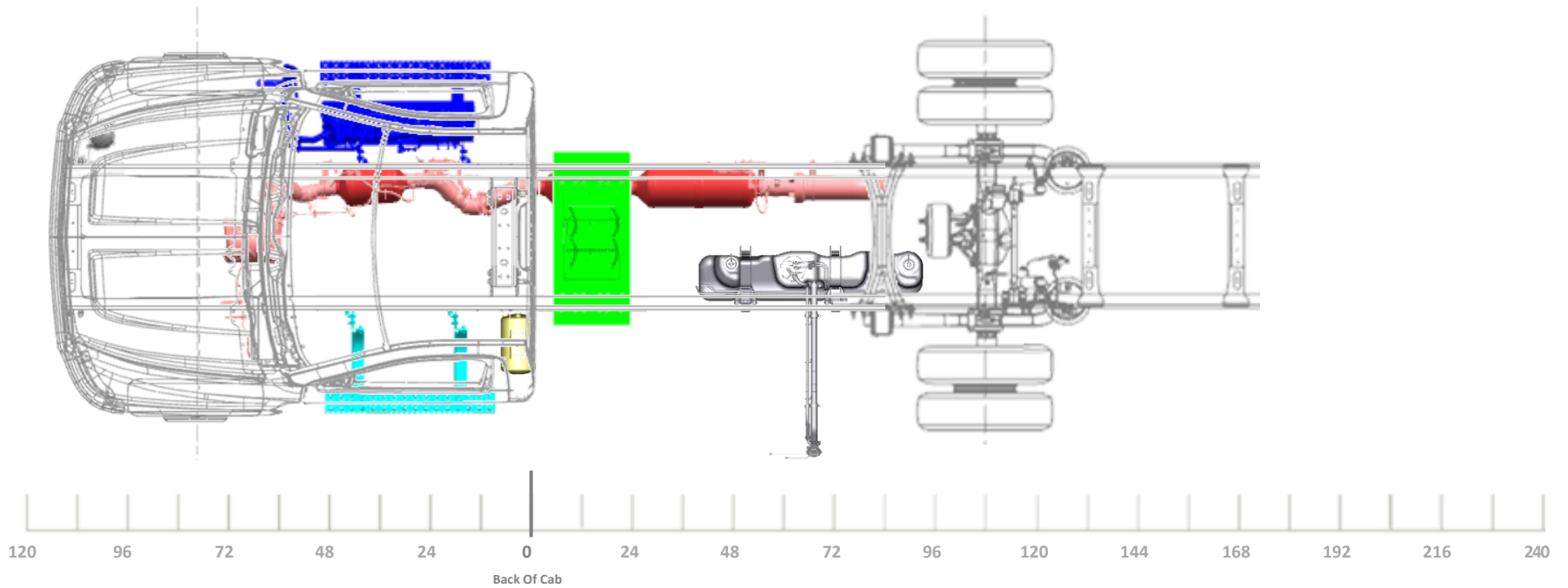

LAST REVISION: 9/25/2023

Model/Feature Information

Model:		C56403 K56403
Cab:		REGULAR CAB
Aftertreatment:		HORIZONTAL
Fuel Tank:	RPO NVK	25 GAL, CA MTD
Battery Box:	RPO 7Y7/7Y8	28" STEEL, 2 BATTERIES
Air Tanks:		(1) OUTSIDE LEFT
DEF Tank:		6.75 GAL
Engine:		6.6L GM DURAMAX

General Configuration Information

4X2 OR 4X4 TRUCK CONFIGURATION
VARI-RATE REAR SUSPENSION
SIDE EXIT TAILPIPE AHEAD OF REAR WHEELS, RT SIDE (RPO NPK)
OPTIONAL AIR DRYER FWD OUTSIDE RT (RPO KUT/JPY)

Minimum Wheelbase

189" WB (108" CA)
49", 63", OR 75" AF

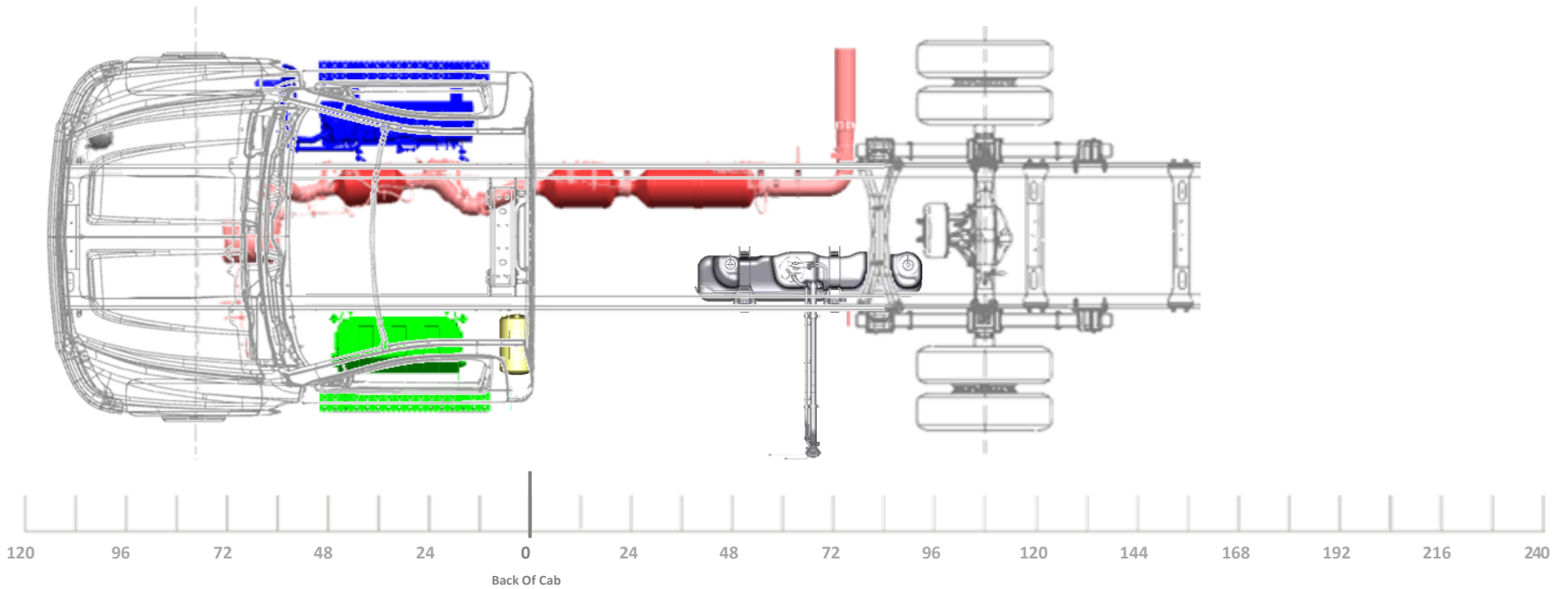

LAST REVISION: 9/25/2023

Model/Feature Information

Model:		C56403 K56403
Cab:		REGULAR CAB
Aftertreatment:		HORIZONTAL
Fuel Tank:	RPO NVK	25 GAL, CA MTD
Battery Box:	RPO 7Y7/7Y8	28" STEEL, 2 BATTERIES
Air Tanks:		(1) OUTSIDE LEFT
DEF Tank:		6.75 GAL
Engine:		6.6L GM DURAMAX

General Configuration Information

4X2 TRUCK CONFIGURATION
REAR AIR SUSPENSION
SIDE EXIT TAILPIPE AHEAD OF REAR WHEELS, RT SIDE (RPO NPK)
OPTIONAL AIR DRYER FWD OUTSIDE RT (RPO KUT/JPY)

Minimum Wheelbase

189" WB (108" CA)
63" OR 75" AF

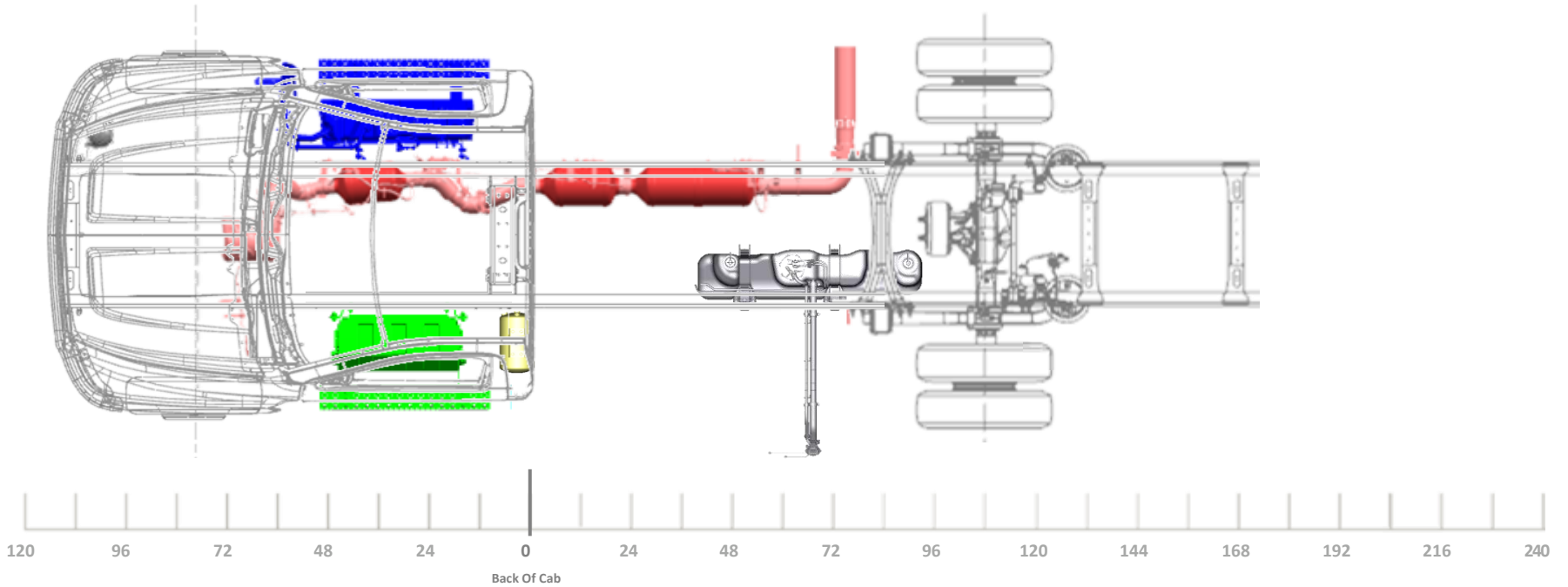

LAST REVISION: 9/25/2023

Model/Feature Information

Model:		C56403 K56403
Cab:		REGULAR CAB
Aftertreatment:		HORIZONTAL
Fuel Tank:	RPO NVK	25 GAL, CA MTD
Battery Box:	RPO 7Y9	TEMP MTD, 3 BATT
Air Tanks:		(1) OUTSIDE LEFT
DEF Tank:		6.75 GAL
Engine:		6.6L GM DURAMAX

General Configuration Information

4X2 OR 4X4 TRUCK CONFIGURATION
 VARI-RATE REAR SUSPENSION

SIDE EXIT TAILPIPE AHEAD OF REAR
 WHEELS, RT SIDE (RPO NPK)

OPTIONAL AIR DRYER FWD OUTSIDE
 RT (RPO KUT/JPY)

Minimum Wheelbase

189" WB (108" CA)
 49", 63", OR 75" AF

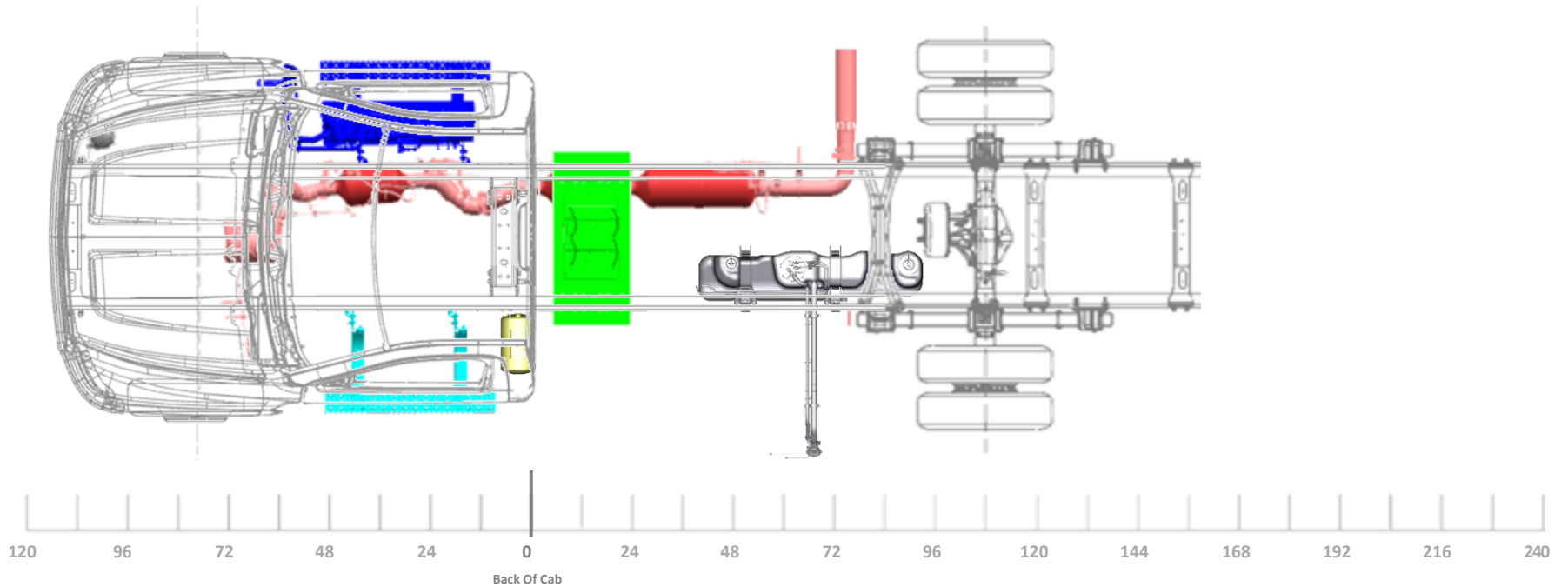

LAST REVISION: 9/25/2023

Model/Feature Information

Model:		C56403 K56403
Cab:		REGULAR CAB
Aftertreatment:		HORIZONTAL
Fuel Tank:	RPO NVK	25 GAL, CA MTD
Battery Box:	RPO 7Y9	TEMP MTD, 3 BATT
Air Tanks:		(1) OUTSIDE LEFT
DEF Tank:		6.75 GAL
Engine:		6.6L GM DURAMAX

General Configuration Information

4X2 TRUCK CONFIGURATION
 REAR AIR SUSPENSION
 SIDE EXIT TAILPIPE AHEAD OF REAR WHEELS, RT SIDE (RPO NPK)
 OPTIONAL AIR DRYER FWD OUTSIDE RT (RPO KUT/JPY)

Minimum Wheelbase

189" WB (108" CA)
 63" OR 75" AF

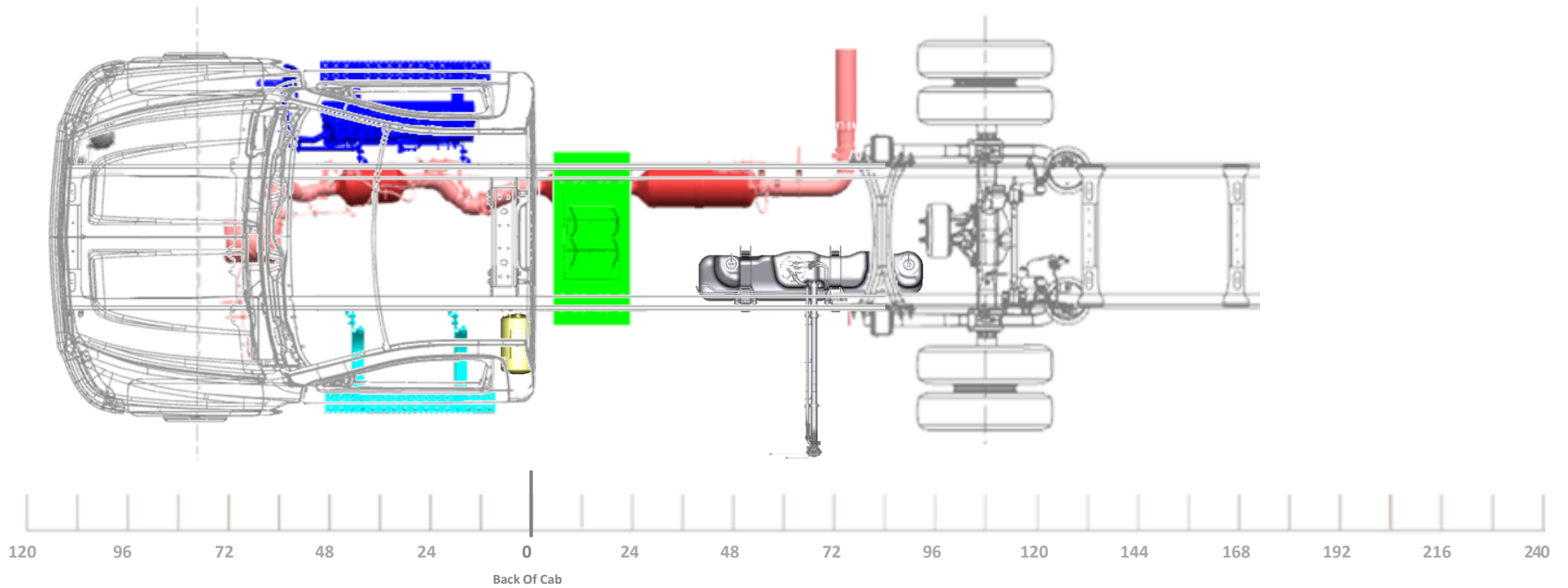

LAST REVISION: 9/25/2023

Model/Feature Information

Model:		C56403 K56403
Cab:		REGULAR CAB
Aftertreatment:		HORIZONTAL
Fuel Tank:	RPO NSQ	DUAL 25G CA, 40G AF
Battery Box:	RPO 7Y7/7Y8	28" STEEL, 2 BATTERIES
Air Tanks:		(1) OUTSIDE LEFT
DEF Tank:		6.75 GAL
Engine:		6.6L GM DURAMAX

General Configuration Information

4X2 OR 4X4 TRUCK CONFIGURATION
 VARI-RATE REAR SUSPENSION

STRAIGHT TAILPIPE (RPO N12)

OPTIONAL AIR DRYER FWD OUTSIDE
 RT (RPO KUT/JPY)

Minimum Wheelbase

189" WB (108" CA)
 49", 63", OR 75" AF

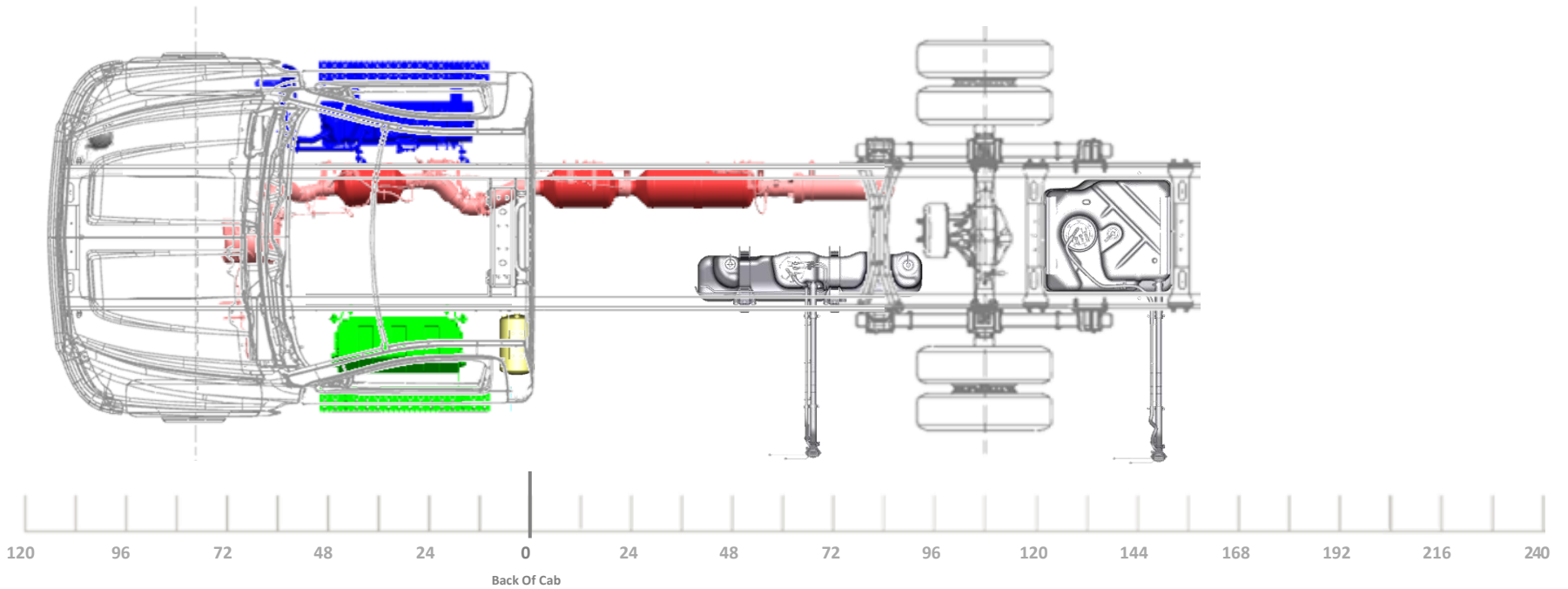

LAST REVISION: 9/25/2023

Model/Feature Information

Model:		C56403 K56403
Cab:		REGULAR CAB
Aftertreatment:		HORIZONTAL
Fuel Tank:	RPO NSQ	DUAL 25G CA, 40G AF
Battery Box:	RPO 7Y7/7Y8	28" STEEL, 2 BATTERIES
Air Tanks:		(1) OUTSIDE LEFT
DEF Tank:		6.75 GAL
Engine:		6.6L GM DURAMAX

General Configuration Information

4X2 TRUCK CONFIGURATION
REAR AIR SUSPENSION
STRAIGHT TAILPIPE (RPO N12)
OPTIONAL AIR DRYER FWD OUTSIDE RT (RPO KUT/JPY)

Minimum Wheelbase

189" WB (108" CA)
63" OR 75" AF

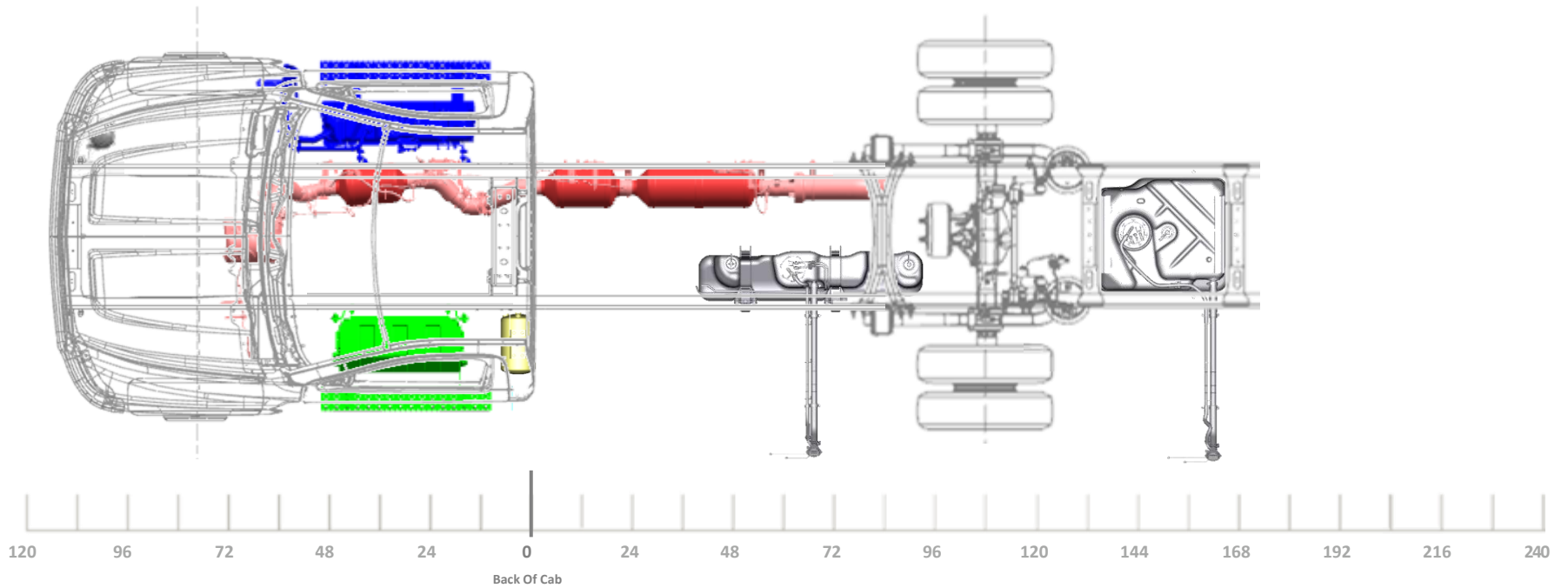

LAST REVISION: 9/25/2023

Model/Feature Information

Model:		C56403 K56403
Cab:		REGULAR CAB
Aftertreatment:		HORIZONTAL
Fuel Tank:	RPO NSQ	DUAL 25G CA, 40G AF
Battery Box:	RPO 7Y9	TEMP MTD, 3 BATT
Air Tanks:		(1) OUTSIDE LEFT
DEF Tank:		6.75 GAL
Engine:		6.6L GM DURAMAX

General Configuration Information

4X2 OR 4X4 TRUCK CONFIGURATION
 VARI-RATE REAR SUSPENSION

STRAIGHT TAILPIPE (RPO N12)

OPTIONAL AIR DRYER FWD OUTSIDE
 RT (RPO KUT/JPY)

Minimum Wheelbase

189" WB (108" CA)
 49", 63", OR 75" AF

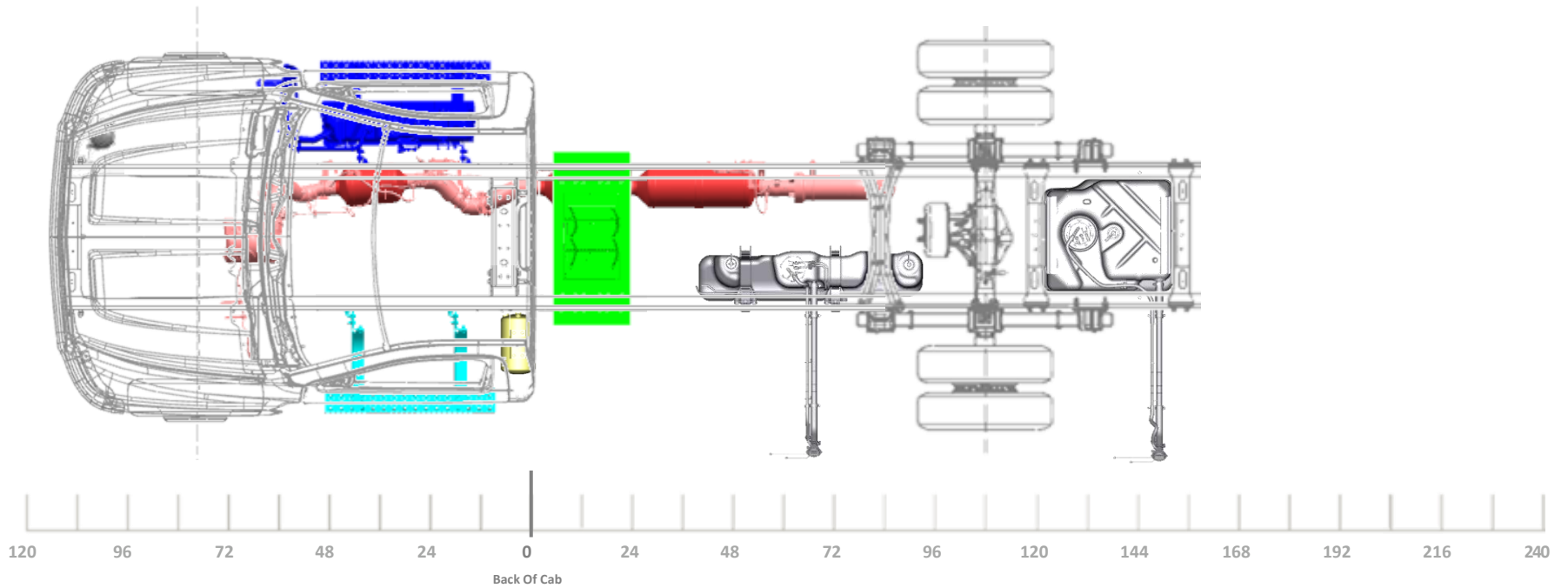

LAST REVISION: 9/25/2023

Model/Feature Information

Model:		C56403 K56403
Cab:		REGULAR CAB
Aftertreatment:		HORIZONTAL
Fuel Tank:	RPO NSQ	DUAL 25G CA, 40G AF
Battery Box:	RPO 7Y9	TEMP MTD, 3 BATT
Air Tanks:		(1) OUTSIDE LEFT
DEF Tank:		6.75 GAL
Engine:		6.6L GM DURAMAX

General Configuration Information

4X2 TRUCK CONFIGURATION
REAR AIR SUSPENSION
STRAIGHT TAILPIPE (RPO N12)
OPTIONAL AIR DRYER FWD OUTSIDE RT (RPO KUT/JPY)

Minimum Wheelbase

189" WB (108" CA)
63" OR 75" AF

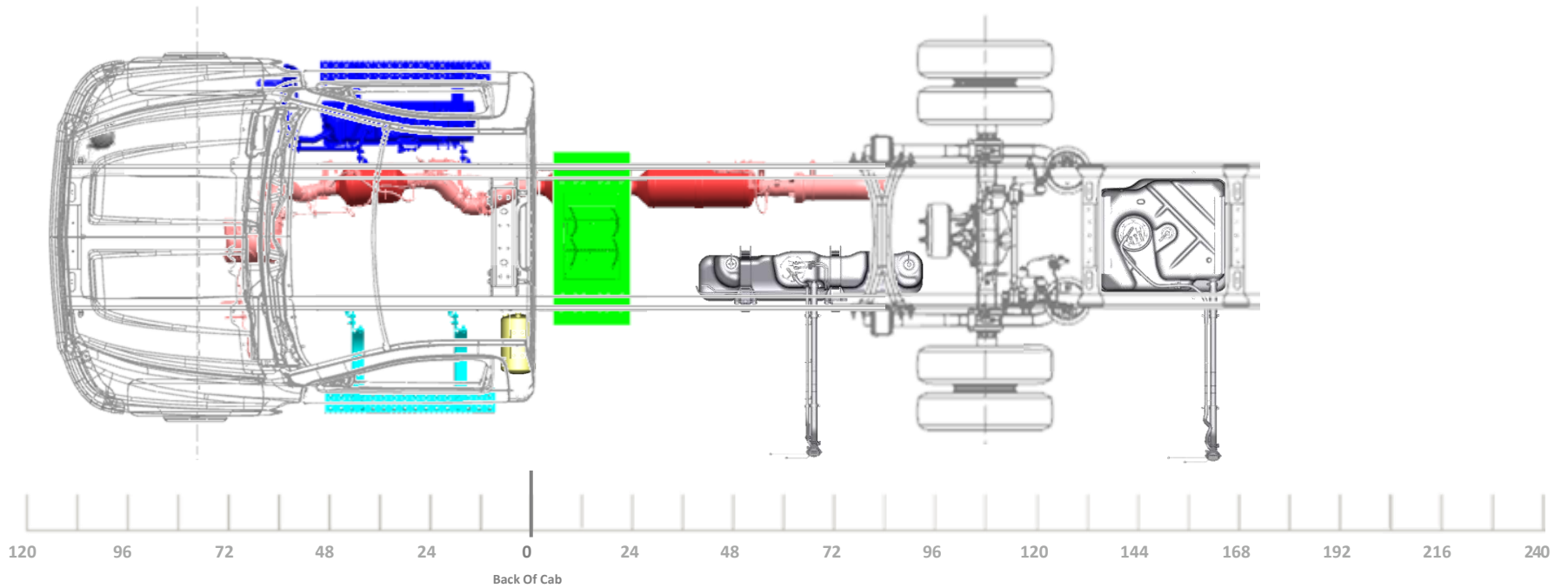

LAST REVISION: 9/25/2023

Model/Feature Information

Model:		C56403 K56403
Cab:		REGULAR CAB
Aftertreatment:		HORIZONTAL
Fuel Tank:	RPO NSQ	DUAL 25G CA, 40G AF
Battery Box:	RPO 7Y7/7Y8	28" STEEL, 2 BATTERIES
Air Tanks:		(1) OUTSIDE LEFT
DEF Tank:		6.75 GAL
Engine:		6.6L GM DURAMAX

General Configuration Information

4X2 OR 4X4 TRUCK CONFIGURATION
 VARI-RATE REAR SUSPENSION

SIDE EXIT TAILPIPE AHEAD OF REAR WHEELS, RT SIDE (RPO NPK)

OPTIONAL AIR DRYER FWD OUTSIDE RT (RPO KUT/JPY)

Minimum Wheelbase

189" WB (108" CA)
 49", 63", OR 75" AF

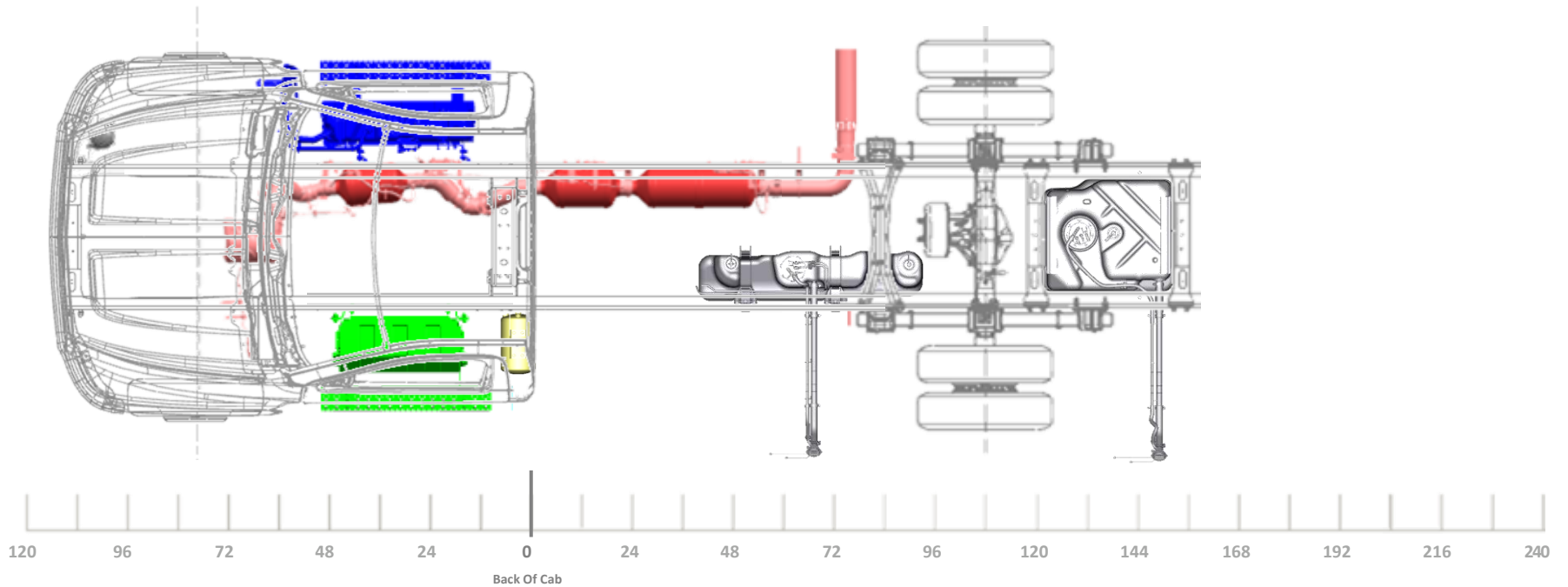

LAST REVISION: 9/25/2023

Model/Feature Information

Model:		C56403 K56403
Cab:		REGULAR CAB
Aftertreatment:		HORIZONTAL
Fuel Tank:	RPO NSQ	DUAL 25G CA, 40G AF
Battery Box:	RPO 7Y7/7Y8	28" STEEL, 2 BATTERIES
Air Tanks:		(1) OUTSIDE LEFT
DEF Tank:		6.75 GAL
Engine:		6.6L GM DURAMAX

General Configuration Information

4X2 TRUCK CONFIGURATION
REAR AIR SUSPENSION
SIDE EXIT TAILPIPE AHEAD OF REAR WHEELS, RT SIDE (RPO NPK)
OPTIONAL AIR DRYER FWD OUTSIDE RT (RPO KUT/JPY)

Minimum Wheelbase

189" WB (108" CA)
63" OR 75" AF

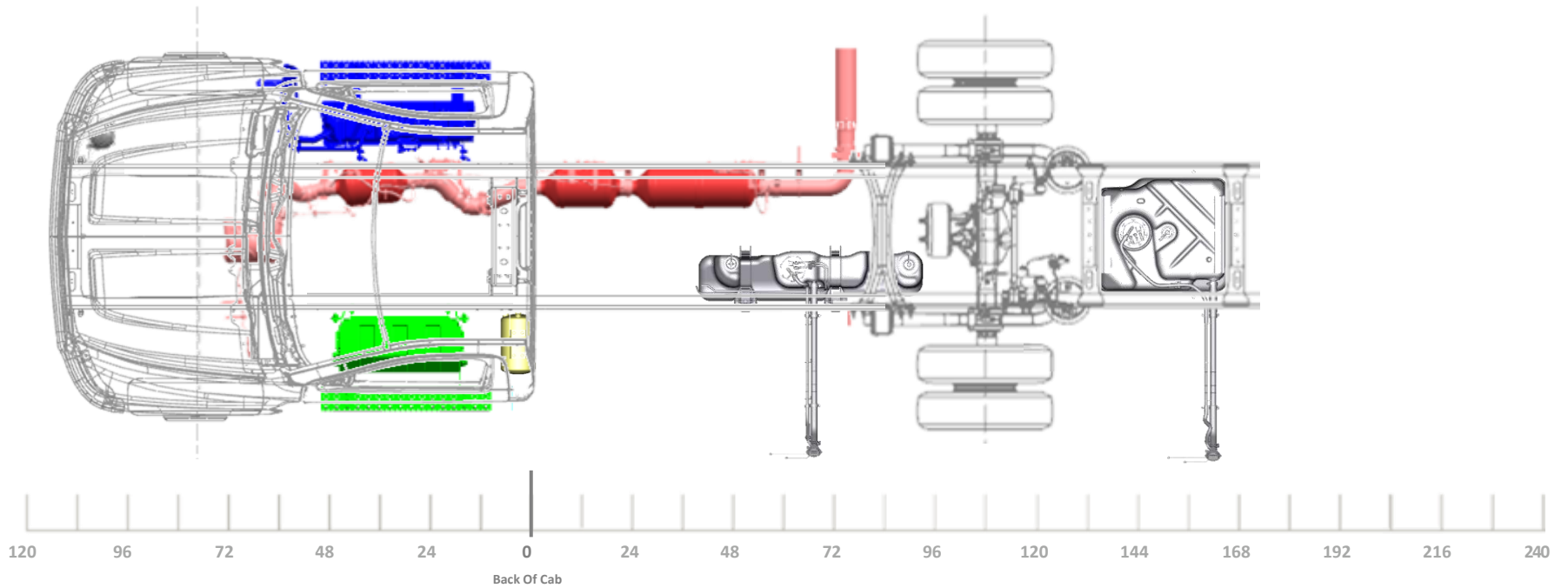

LAST REVISION: 9/25/2023

Model/Feature Information

Model:		C56403 K56403
Cab:		REGULAR CAB
Aftertreatment:		HORIZONTAL
Fuel Tank:	RPO NSQ	DUAL 25G CA, 40G AF
Battery Box:	RPO 7Y9	TEMP MTD, 3 BATT
Air Tanks:		(1) OUTSIDE LEFT
DEF Tank:		6.75 GAL
Engine:		6.6L GM DURAMAX

General Configuration Information

4X2 OR 4X4 TRUCK CONFIGURATION
 VARI-RATE REAR SUSPENSION

SIDE EXIT TAILPIPE AHEAD OF REAR WHEELS, RT SIDE (RPO NPK)

OPTIONAL AIR DRYER FWD OUTSIDE RT (RPO KUT/JPY)

Minimum Wheelbase

189" WB (108" CA)
 49", 63", OR 75" AF

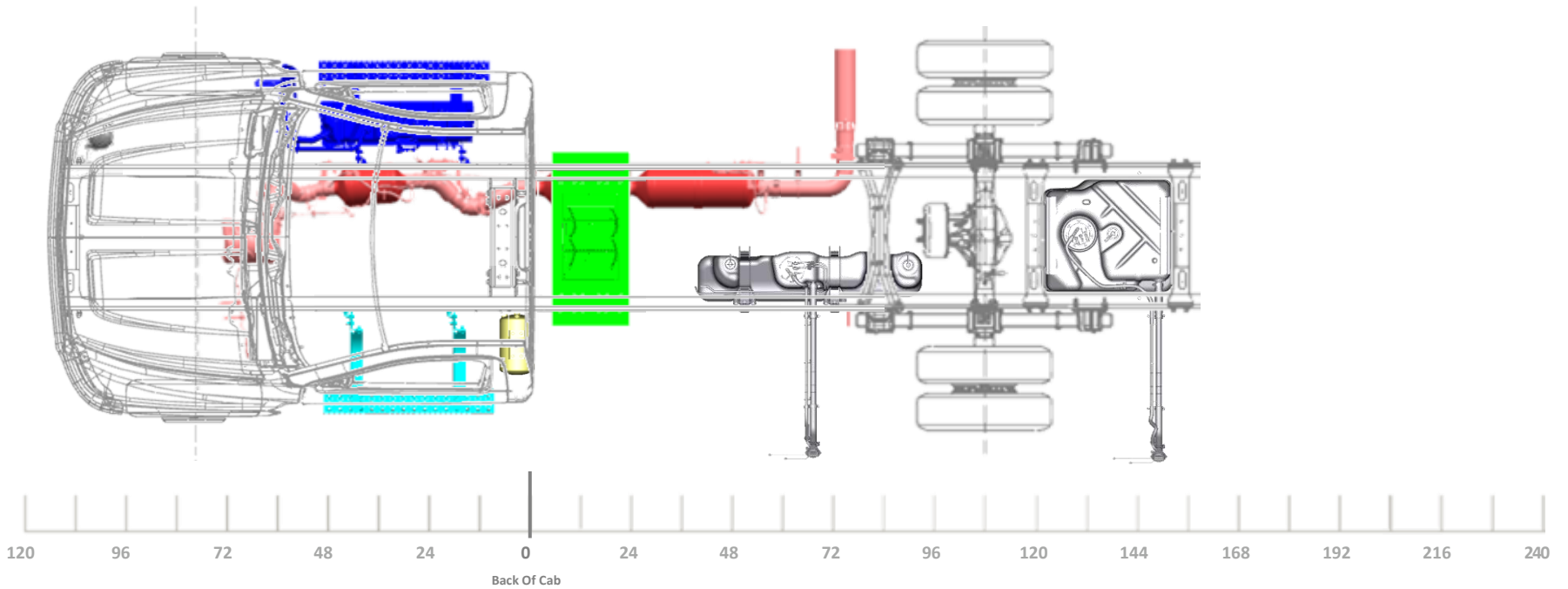

LAST REVISION: 9/25/2023

Model/Feature Information

Model:		C56403 K56403
Cab:		REGULAR CAB
Aftertreatment:		HORIZONTAL
Fuel Tank:	RPO NSQ	DUAL 25G CA, 40G AF
Battery Box:	RPO 7Y9	TEMP MTD, 3 BATT
Air Tanks:		(1) OUTSIDE LEFT
DEF Tank:		6.75 GAL
Engine:		6.6L GM DURAMAX

General Configuration Information

4X2 TRUCK CONFIGURATION
REAR AIR SUSPENSION
SIDE EXIT TAILPIPE AHEAD OF REAR WHEELS, RT SIDE (RPO NPK)
OPTIONAL AIR DRYER FWD OUTSIDE RT (RPO KUT/JPY)

Minimum Wheelbase

189" WB (108" CA)
63" OR 75" AF

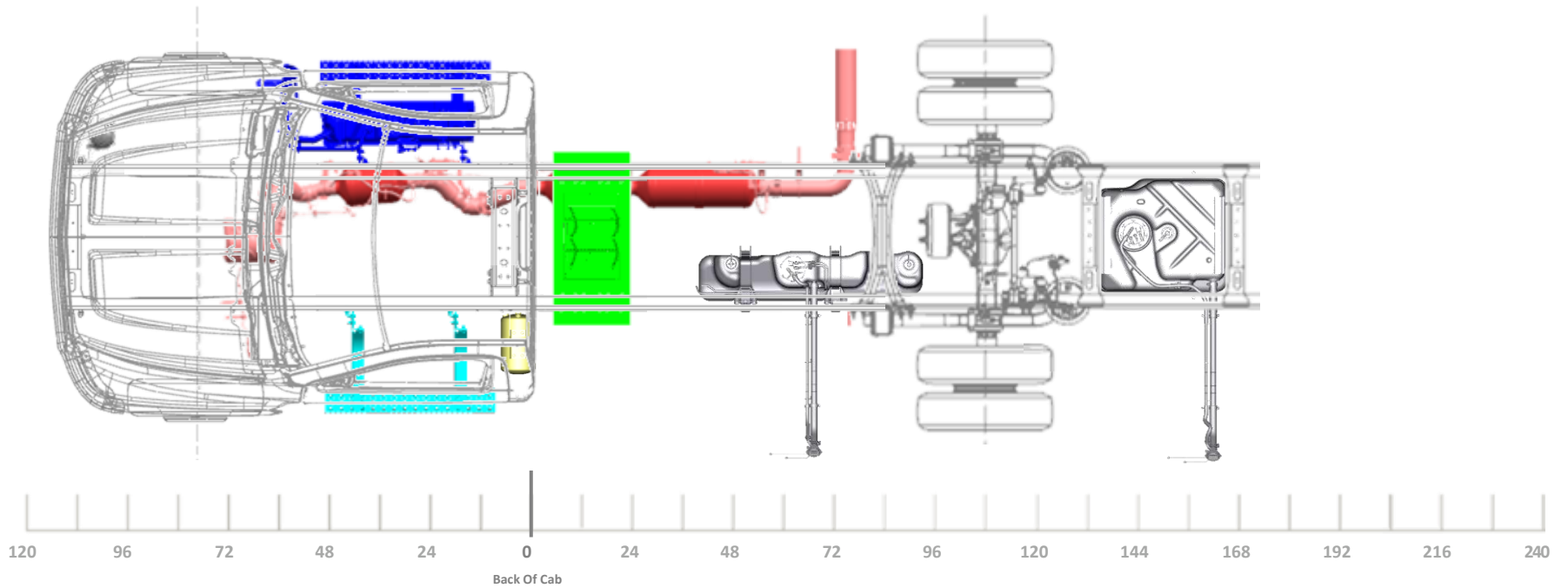

LAST REVISION: 9/25/2023

REGULAR
CAB 201”
WB

Model/Feature Information

Model:		C56403 K56403
Cab:		REGULAR CAB
Aftertreatment:		HORIZONTAL
Fuel Tank:	RPO N2L	40 GAL, AF MTD
Battery Box:	RPO 7Y7/7Y8	28" STEEL, 2 BATTERIES
Air Tanks:		(1) OUTSIDE LEFT
DEF Tank:		6.75 GAL
Engine:		6.6L GM DURAMAX

General Configuration Information

4X2 OR 4X4 TRUCK CONFIGURATION
 VARI-RATE REAR SUSPENSION

STRAIGHT TAILPIPE (RPO N12)

OPTIONAL AIR DRYER FWD OUTSIDE
 RT (RPO KUT/JPY)

Minimum Wheelbase

201" WB (120" CA)
 49", 63", OR 75" AF

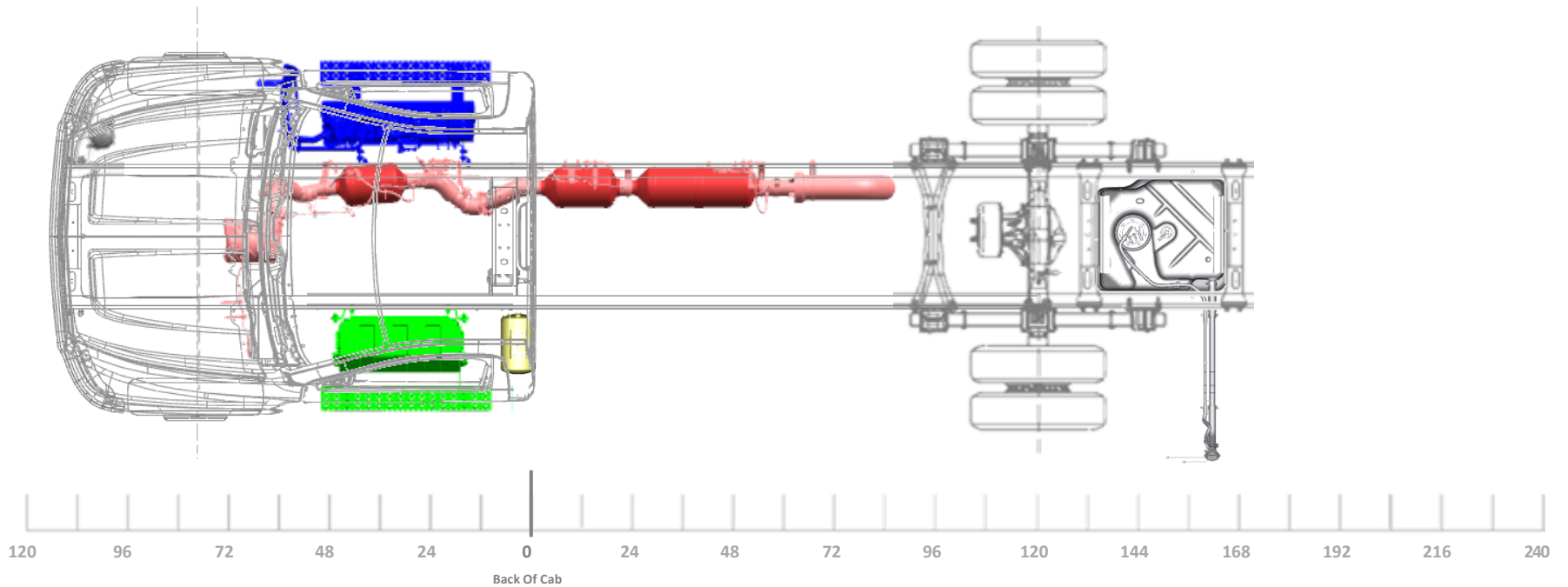

LAST REVISION: 9/25/2023

Model/Feature Information

Model:		C56403 K56403
Cab:		REGULAR CAB
Aftertreatment:		HORIZONTAL
Fuel Tank:	RPO N2L	40 GAL, AF MTD
Battery Box:	RPO 7Y7/7Y8	28" STEEL, 2 BATTERIES
Air Tanks:		(1) OUTSIDE LEFT
DEF Tank:		6.75 GAL
Engine:		6.6L GM DURAMAX

General Configuration Information

4X2 TRUCK CONFIGURATION
REAR AIR SUSPENSION
STRAIGHT TAILPIPE (RPO N12)
OPTIONAL AIR DRYER FWD OUTSIDE RT (RPO KUT/JPY)

Minimum Wheelbase

201" WB (120" CA)
63" OR 75" AF

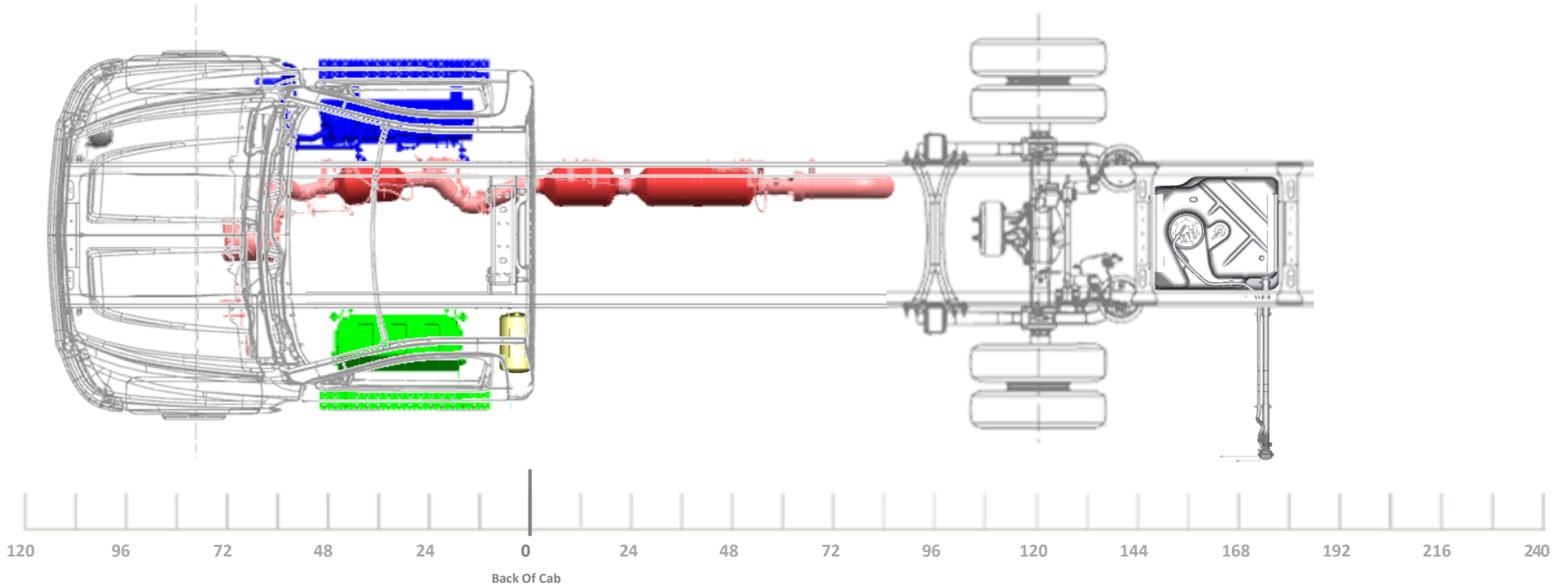

LAST REVISION: 9/25/2023

Model/Feature Information

Model:		C56403 K56403
Cab:		REGULAR CAB
Aftertreatment:		HORIZONTAL
Fuel Tank:	RPO N2L	40 GAL, AF MTD
Battery Box:	RPO 7Y9	TEMP MTD, 3 BATT
Air Tanks:		(1) OUTSIDE LEFT
DEF Tank:		6.75 GAL
Engine:		6.6L GM DURAMAX

General Configuration Information

4X2 OR 4X4 TRUCK CONFIGURATION
 VARI-RATE REAR SUSPENSION

STRAIGHT TAILPIPE (RPO N12)

OPTIONAL AIR DRYER FWD OUTSIDE
 RT (RPO KUT/JPY)

Minimum Wheelbase

201" WB (120" CA)
 49", 63", OR 75" AF

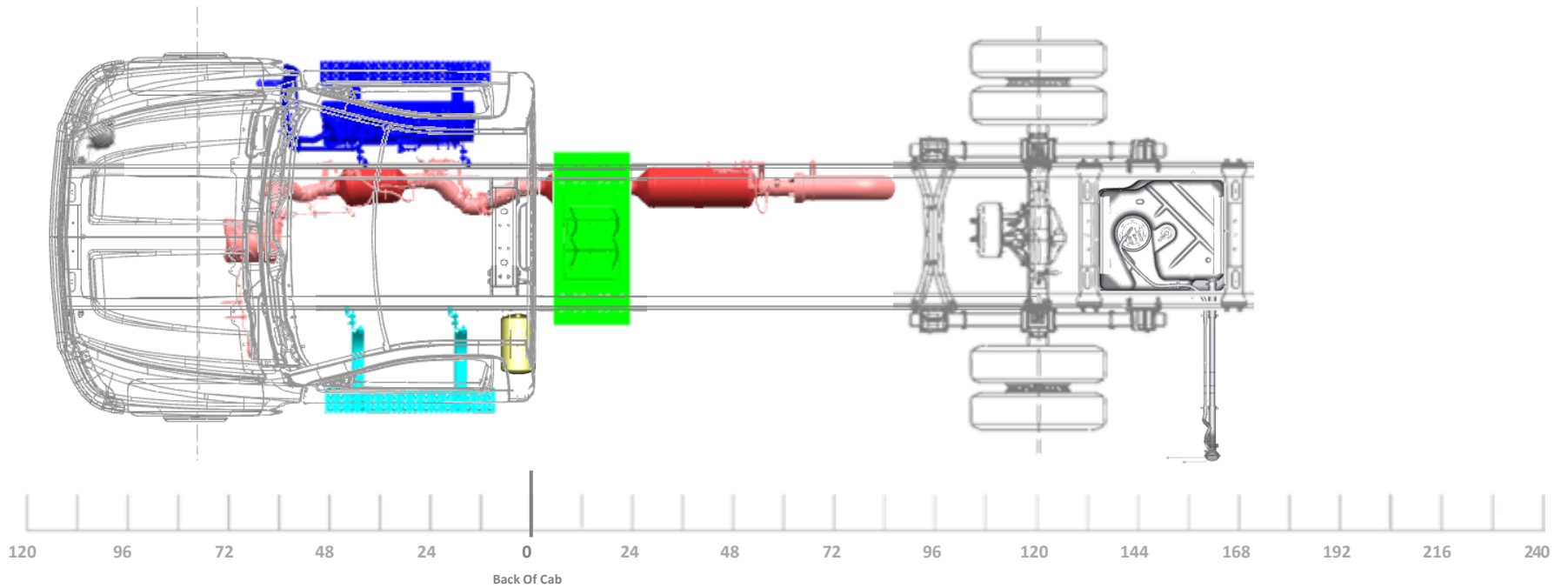

LAST REVISION: 9/25/2023

Model/Feature Information

Model:		C56403 K56403
Cab:		REGULAR CAB
Aftertreatment:		HORIZONTAL
Fuel Tank:	RPO N2L	40 GAL, AF MTD
Battery Box:	RPO 7Y9	TEMP MTD, 3 BATT
Air Tanks:		(1) OUTSIDE LEFT
DEF Tank:		6.75 GAL
Engine:		6.6L GM DURAMAX

General Configuration Information

4X2 TRUCK CONFIGURATION
REAR AIR SUSPENSION
STRAIGHT TAILPIPE (RPO N12)
OPTIONAL AIR DRYER FWD OUTSIDE RT (RPO KUT/JPY)

Minimum Wheelbase

201" WB (120" CA)
63" OR 75" AF

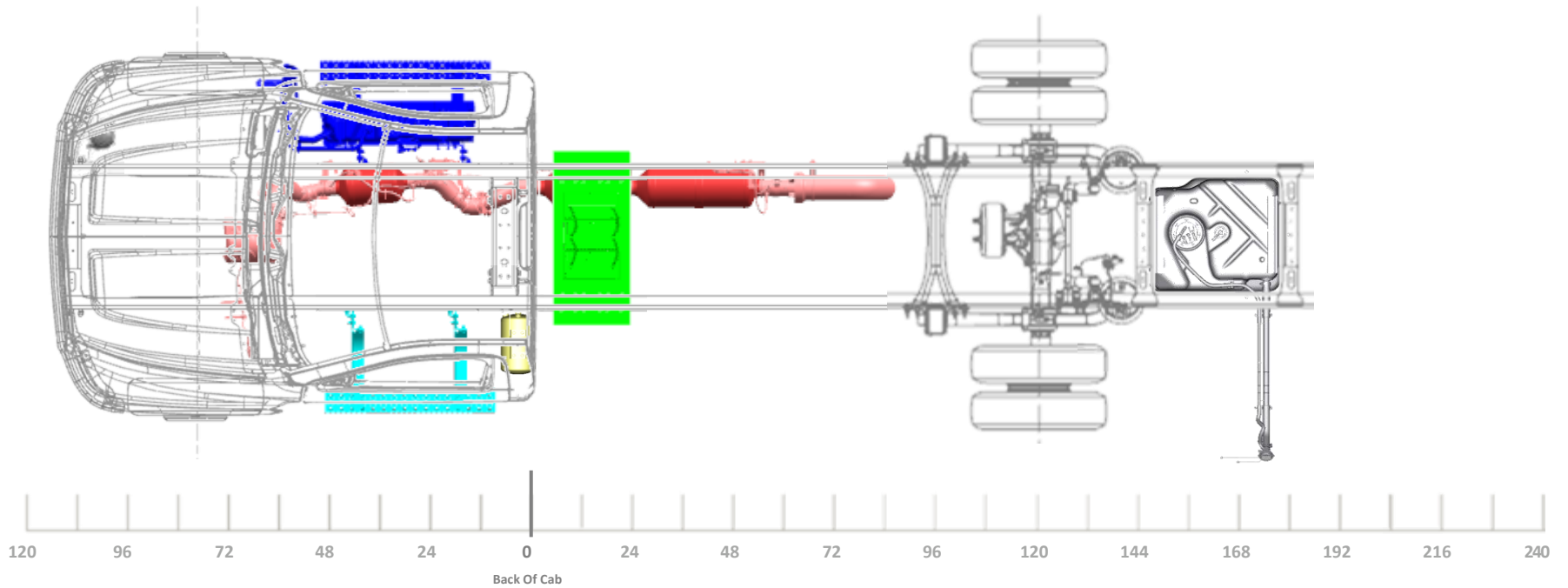

LAST REVISION: 9/25/2023

Model/Feature Information

Model:		C56403 K56403
Cab:		REGULAR CAB
Aftertreatment:		HORIZONTAL
Fuel Tank:	RPO N2L	40 GAL, AF MTD
Battery Box:	RPO 7Y7/7Y8	28" STEEL, 2 BATTERIES
Air Tanks:		(1) OUTSIDE LEFT
DEF Tank:		6.75 GAL
Engine:		6.6L GM DURAMAX

General Configuration Information

4X2 OR 4X4 TRUCK CONFIGURATION
VARI-RATE REAR SUSPENSION

SIDE EXIT TAILPIPE AHEAD OF REAR
WHEELS, LT SIDE (RPO NPJ)

OPTIONAL AIR DRYER FWD OUTSIDE
RT (RPO KUT/JPY)

Minimum Wheelbase

201" WB (120" CA)
49", 63", OR 75" AF

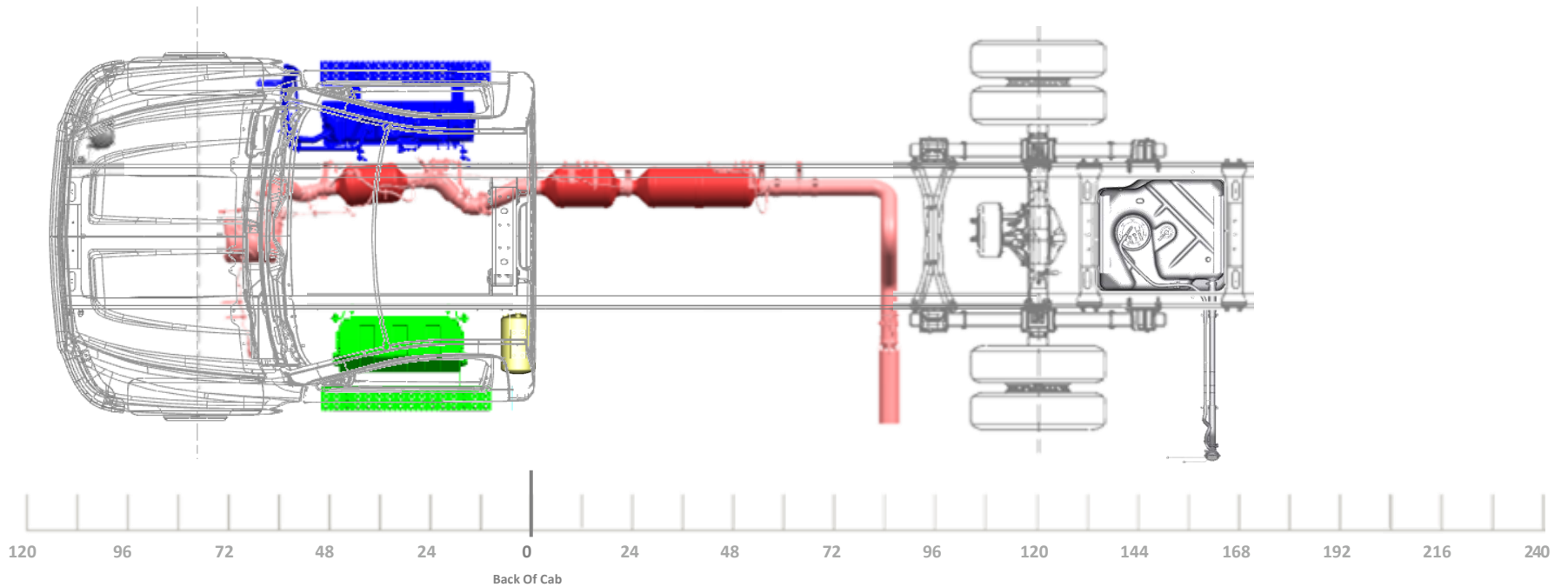

LAST REVISION: 9/25/2023

Model/Feature Information

Model:		C56403 K56403
Cab:		REGULAR CAB
Aftertreatment:		HORIZONTAL
Fuel Tank:	RPO N2L	40 GAL, AF MTD
Battery Box:	RPO 7Y7/7Y8	28" STEEL, 2 BATTERIES
Air Tanks:		(1) OUTSIDE LEFT
DEF Tank:		6.75 GAL
Engine:		6.6L GM DURAMAX

General Configuration Information

4X2 TRUCK CONFIGURATION
 REAR AIR SUSPENSION
 SIDE EXIT TAILPIPE AHEAD OF REAR WHEELS, LT SIDE (RPO NPJ)
 OPTIONAL AIR DRYER FWD OUTSIDE RT (RPO KUT/JPY)

Minimum Wheelbase

201" WB (120" CA)
 63" OR 75" AF

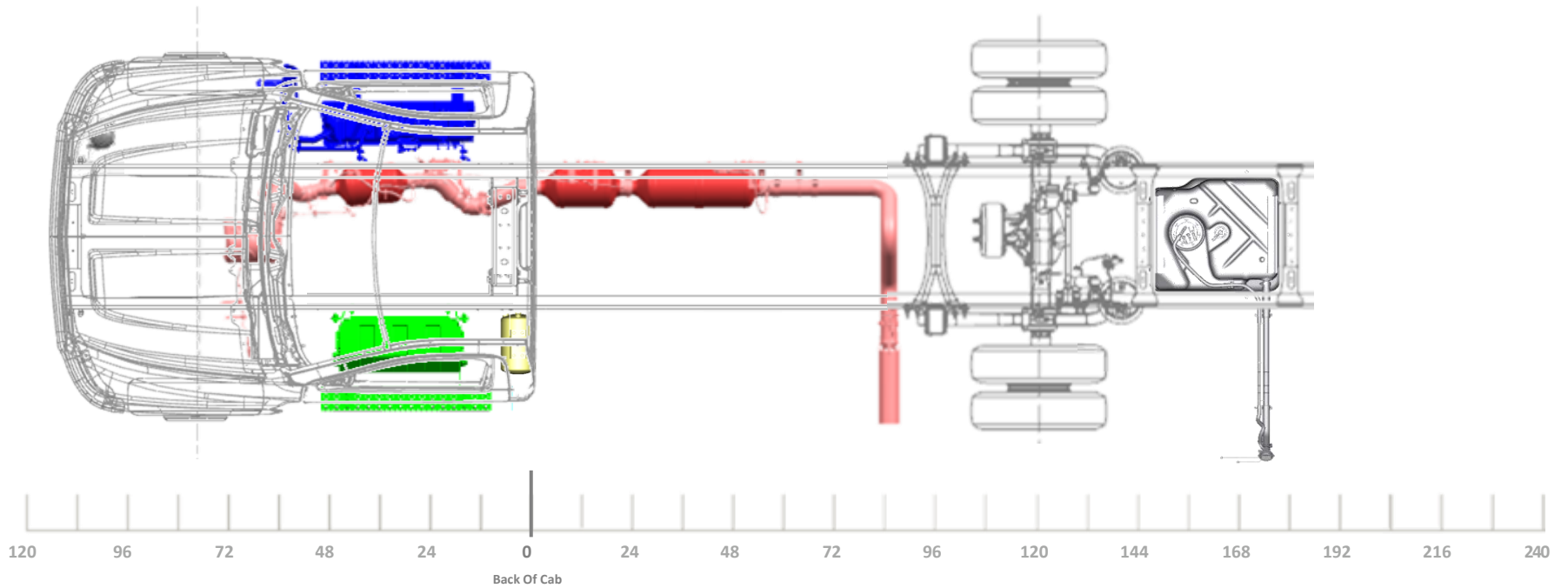

LAST REVISION: 9/25/2023

Model/Feature Information

Model:		C56403 K56403
Cab:		REGULAR CAB
Aftertreatment:		HORIZONTAL
Fuel Tank:	RPO N2L	40 GAL, AF MTD
Battery Box:	RPO 7Y9	TEMP MTD, 3 BATT
Air Tanks:		(1) OUTSIDE LEFT
DEF Tank:		6.75 GAL
Engine:		6.6L GM DURAMAX

General Configuration Information

4X2 OR 4X4 TRUCK CONFIGURATION
 VARI-RATE REAR SUSPENSION

SIDE EXIT TAILPIPE AHEAD OF REAR
 WHEELS, LT SIDE (RPO NPJ)

OPTIONAL AIR DRYER FWD OUTSIDE
 RT (RPO KUT/JPY)

Minimum Wheelbase

201" WB (120" CA)
 49", 63", OR 75" AF

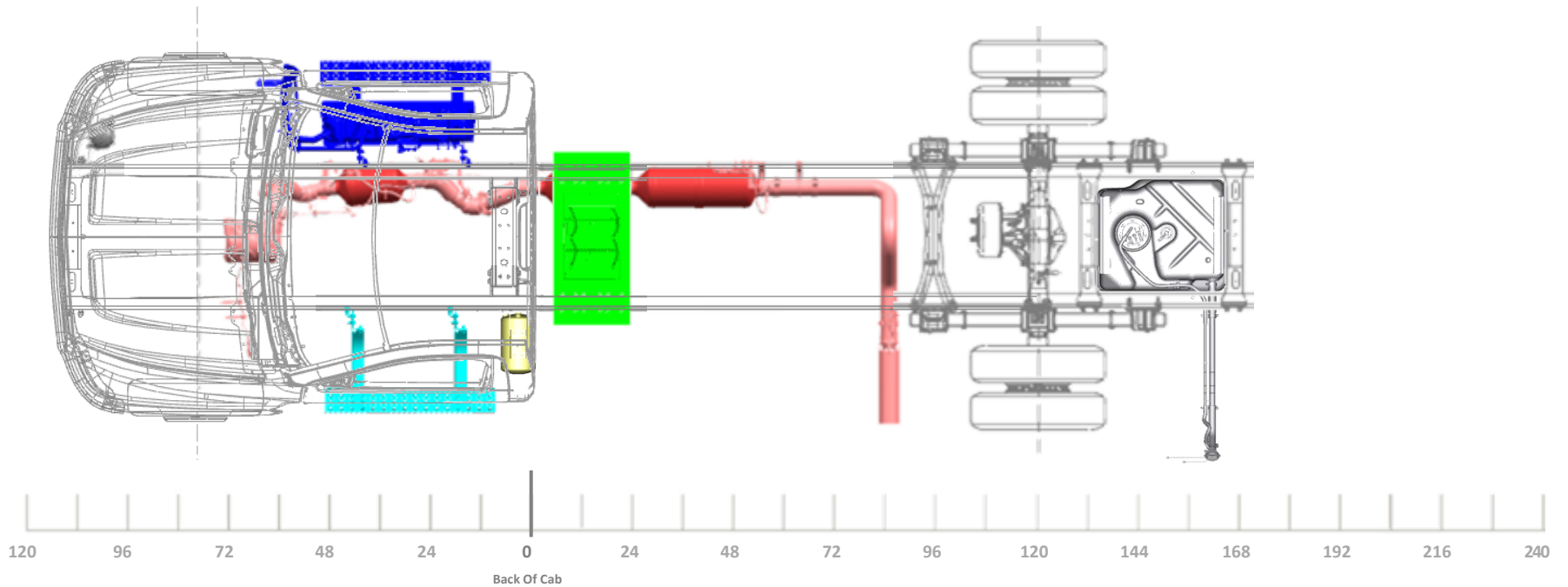

LAST REVISION: 9/25/2023

Model/Feature Information

Model:		C56403 K56403
Cab:		REGULAR CAB
Aftertreatment:		HORIZONTAL
Fuel Tank:	RPO N2L	40 GAL, AF MTD
Battery Box:	RPO 7Y9	TEMP MTD, 3 BATT
Air Tanks:		(1) OUTSIDE LEFT
DEF Tank:		6.75 GAL
Engine:		6.6L GM DURAMAX

General Configuration Information

4X2 TRUCK CONFIGURATION
 REAR AIR SUSPENSION
 SIDE EXIT TAILPIPE AHEAD OF REAR WHEELS, LT SIDE (RPO NPJ)
 OPTIONAL AIR DRYER FWD OUTSIDE RT (RPO KUT/JPY)

Minimum Wheelbase

201" WB (120" CA)
 63" OR 75" AF

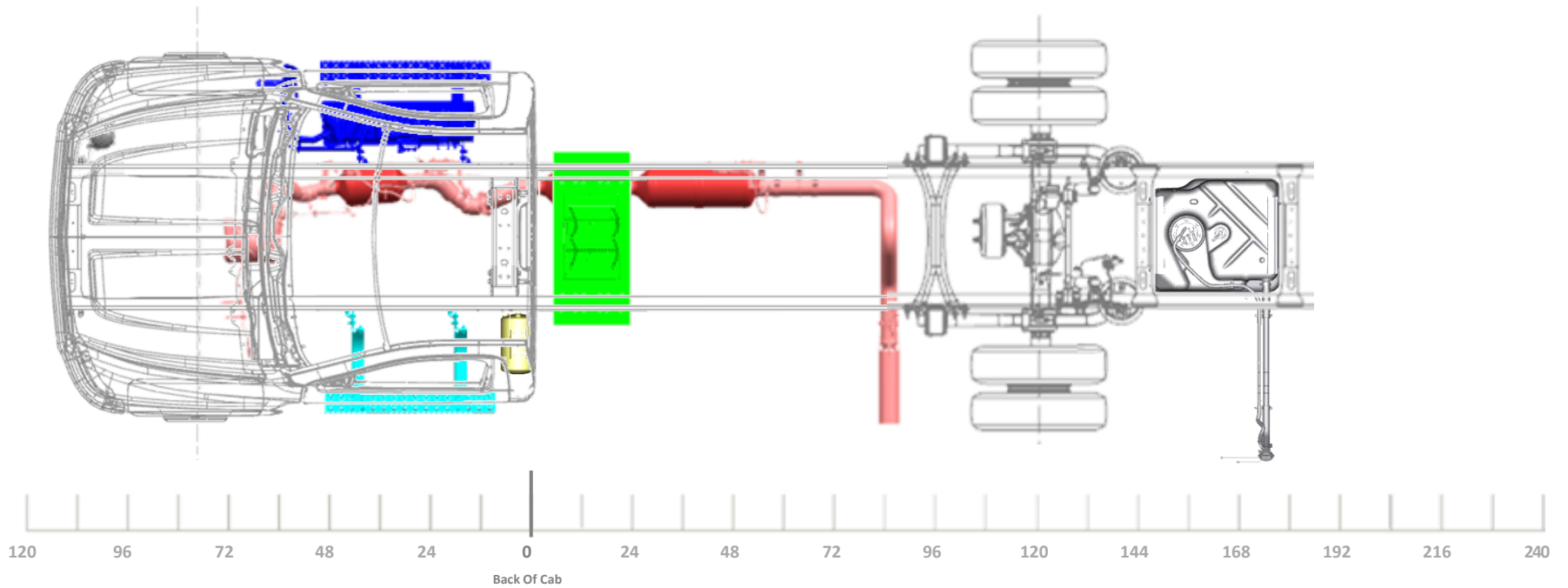

LAST REVISION: 9/25/2023

Model/Feature Information

Model:		C56403 K56403
Cab:		REGULAR CAB
Aftertreatment:		HORIZONTAL
Fuel Tank:	RPO N2L	40 GAL, AF MTD
Battery Box:	RPO 7Y7/7Y8	28" STEEL, 2 BATTERIES
Air Tanks:		(1) OUTSIDE LEFT
DEF Tank:		6.75 GAL
Engine:		6.6L GM DURAMAX

General Configuration Information

4X2 OR 4X4 TRUCK CONFIGURATION
VARI-RATE REAR SUSPENSION
SIDE EXIT TAILPIPE AHEAD OF REAR WHEELS, RT SIDE (RPO NPK)
OPTIONAL AIR DRYER FWD OUTSIDE RT (RPO KUT/JPY)

Minimum Wheelbase

201" WB (120" CA)
49", 63", OR 75" AF

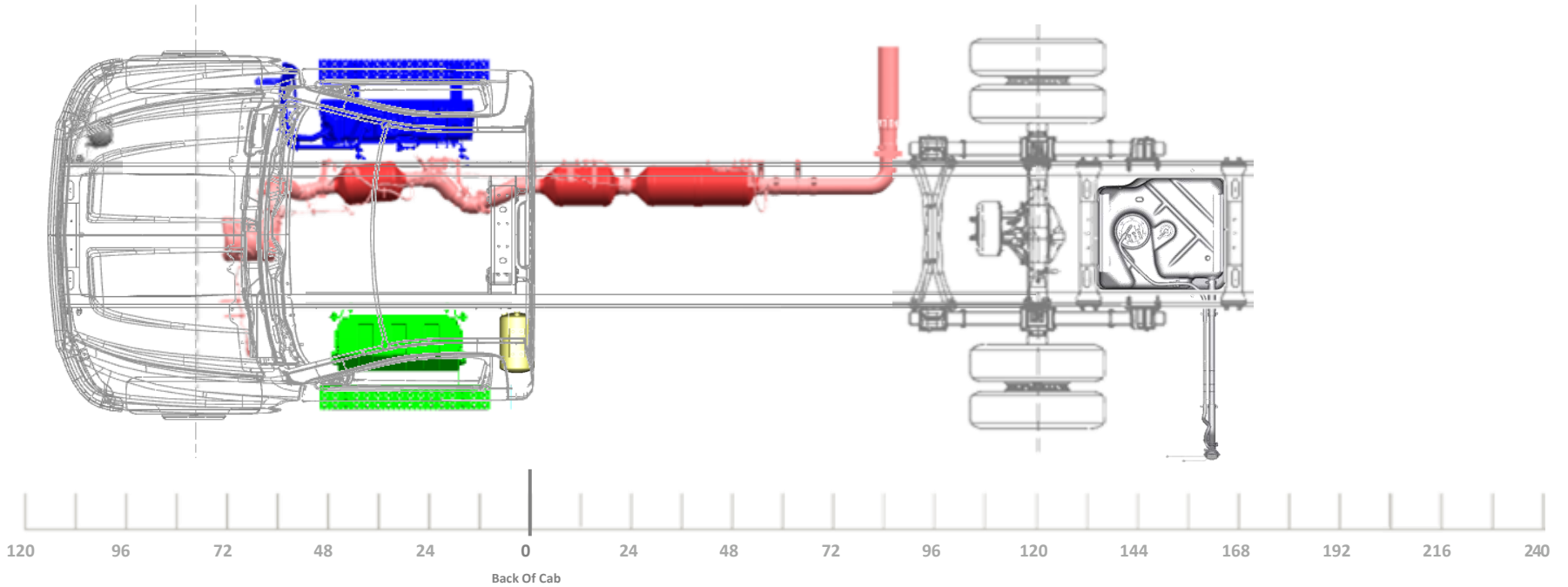

LAST REVISION: 9/25/2023

Model/Feature Information

Model:		C56403 K56403
Cab:		REGULAR CAB
Aftertreatment:		HORIZONTAL
Fuel Tank:	RPO N2L	40 GAL, AF MTD
Battery Box:	RPO 7Y7/7Y8	28" STEEL, 2 BATTERIES
Air Tanks:		(1) OUTSIDE LEFT
DEF Tank:		6.75 GAL
Engine:		6.6L GM DURAMAX

General Configuration Information

4X2 TRUCK CONFIGURATION
 REAR AIR SUSPENSION
 SIDE EXIT TAILPIPE AHEAD OF REAR WHEELS, RT SIDE (RPO NPK)
 OPTIONAL AIR DRYER FWD OUTSIDE RT (RPO KUT/JPY)

Minimum Wheelbase

201" WB (120" CA)
 63" OR 75" AF

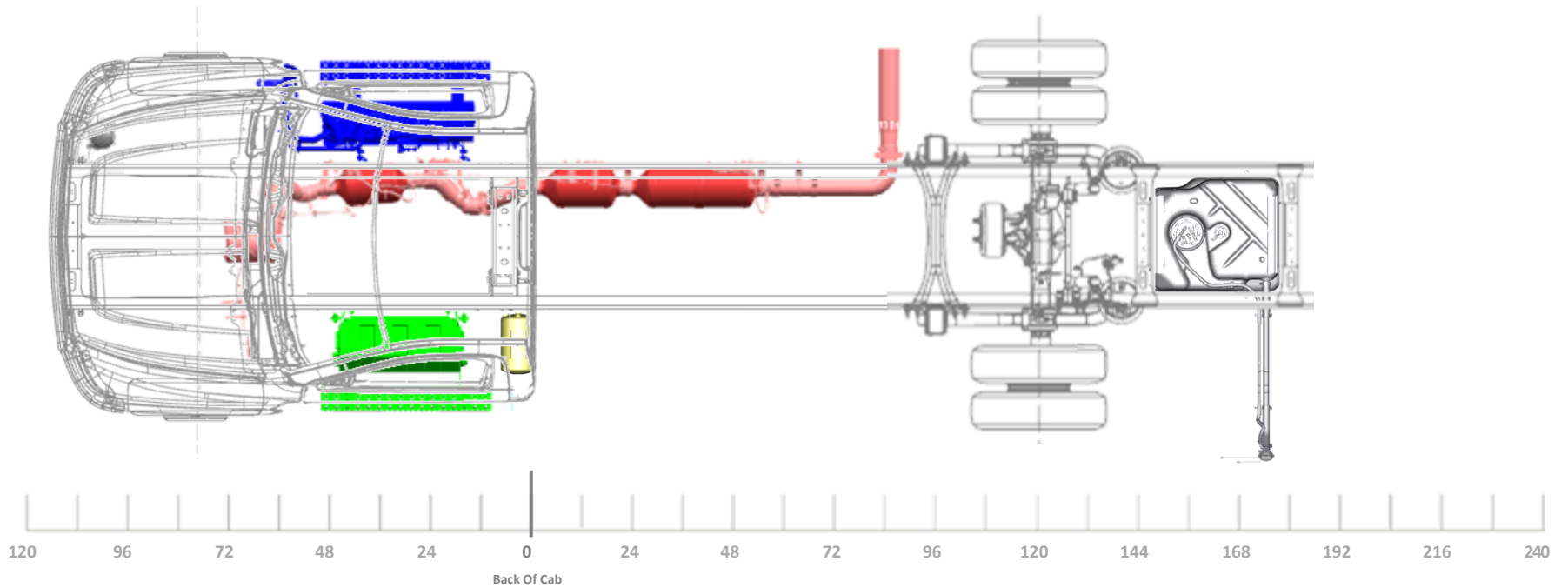

LAST REVISION: 9/25/2023

Model/Feature Information

Model:		C56403 K56403
Cab:		REGULAR CAB
Aftertreatment:		HORIZONTAL
Fuel Tank:	RPO N2L	40 GAL, AF MTD
Battery Box:	RPO 7Y9	TEMP MTD, 3 BATT
Air Tanks:		(1) OUTSIDE LEFT
DEF Tank:		6.75 GAL
Engine:		6.6L GM DURAMAX

General Configuration Information

4X2 OR 4X4 TRUCK CONFIGURATION
VARI-RATE REAR SUSPENSION

SIDE EXIT TAILPIPE AHEAD OF REAR
WHEELS, RT SIDE (RPO NPK)

OPTIONAL AIR DRYER FWD OUTSIDE
RT (RPO KUT/JPY)

Minimum Wheelbase

201" WB (120" CA)
49", 63", OR 75" AF

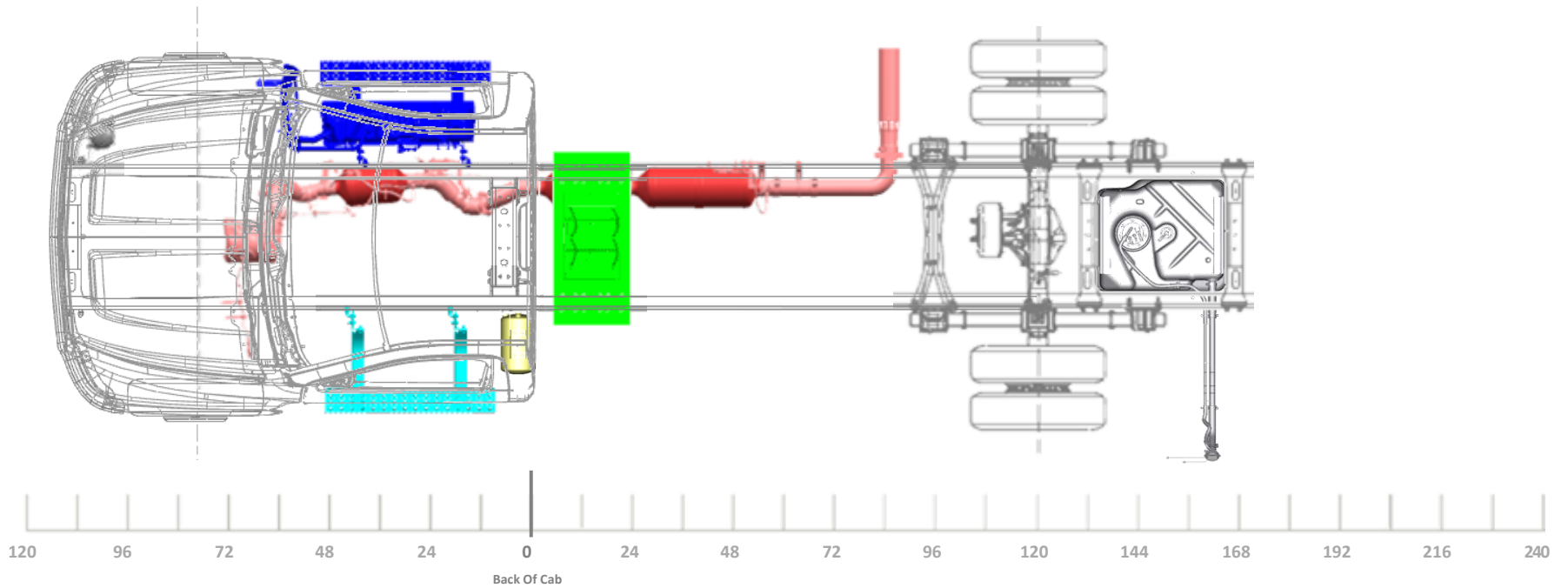

LAST REVISION: 9/25/2023

Model/Feature Information

Model:		C56403 K56403
Cab:		REGULAR CAB
Aftertreatment:		HORIZONTAL
Fuel Tank:	RPO N2L	40 GAL, AF MTD
Battery Box:	RPO 7Y9	TEMP MTD, 3 BATT
Air Tanks:		(1) OUTSIDE LEFT
DEF Tank:		6.75 GAL
Engine:		6.6L GM DURAMAX

General Configuration Information

4X2 TRUCK CONFIGURATION
 REAR AIR SUSPENSION

SIDE EXIT TAILPIPE AHEAD OF REAR WHEELS, RT SIDE (RPO NPK)

OPTIONAL AIR DRYER FWD OUTSIDE RT (RPO KUT/JPY)

Minimum Wheelbase

201" WB (120" CA)
 63" OR 75" AF

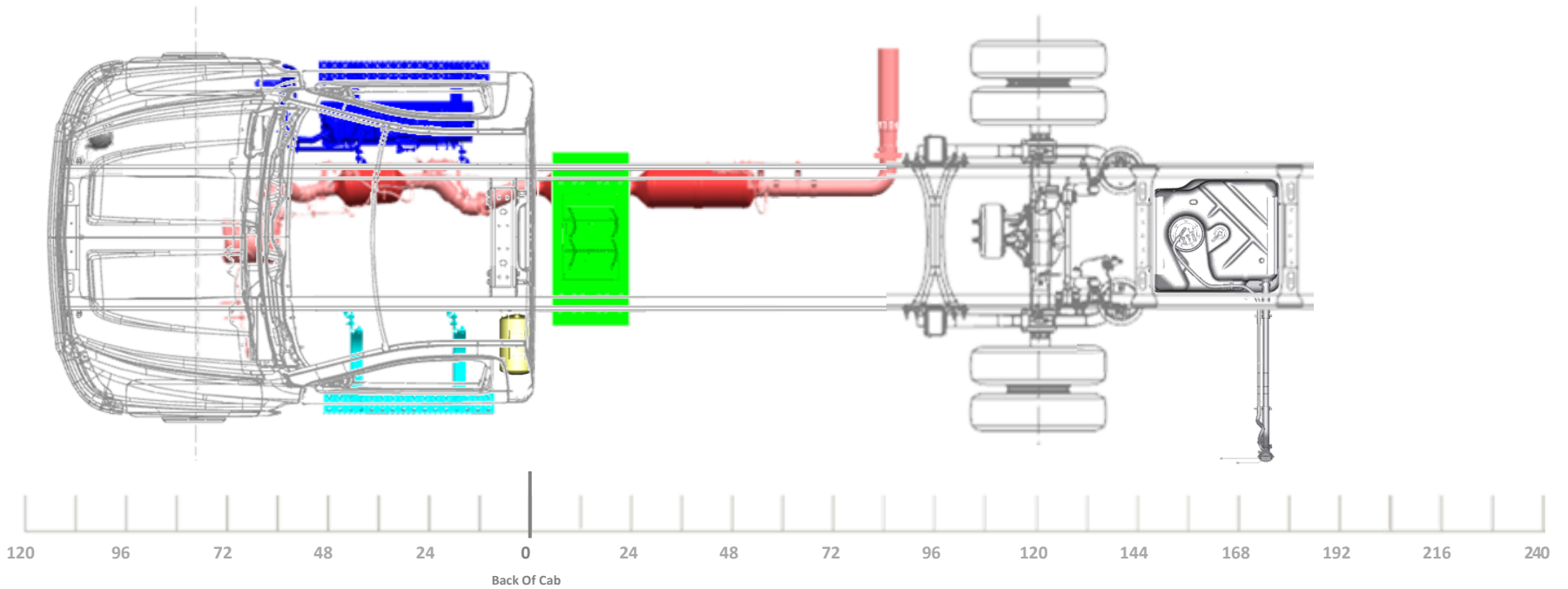

LAST REVISION: 9/25/2023

Model/Feature Information

Model:		C56403 K56403
Cab:		REGULAR CAB
Aftertreatment:		HORIZONTAL
Fuel Tank:	RPO NVK	25 GAL, CA MTD
Battery Box:	RPO 7Y7/7Y8	28" STEEL, 2 BATTERIES
Air Tanks:		(1) OUTSIDE LEFT
DEF Tank:		6.75 GAL
Engine:		6.6L GM DURAMAX

General Configuration Information

4X2 OR 4X4 TRUCK CONFIGURATION
 VARI-RATE REAR SUSPENSION

STRAIGHT TAILPIPE (RPO N12)

OPTIONAL AIR DRYER FWD OUTSIDE
 RT (RPO KUT/JPY)

Minimum Wheelbase

201" WB (120" CA)
 49", 63", OR 75" AF

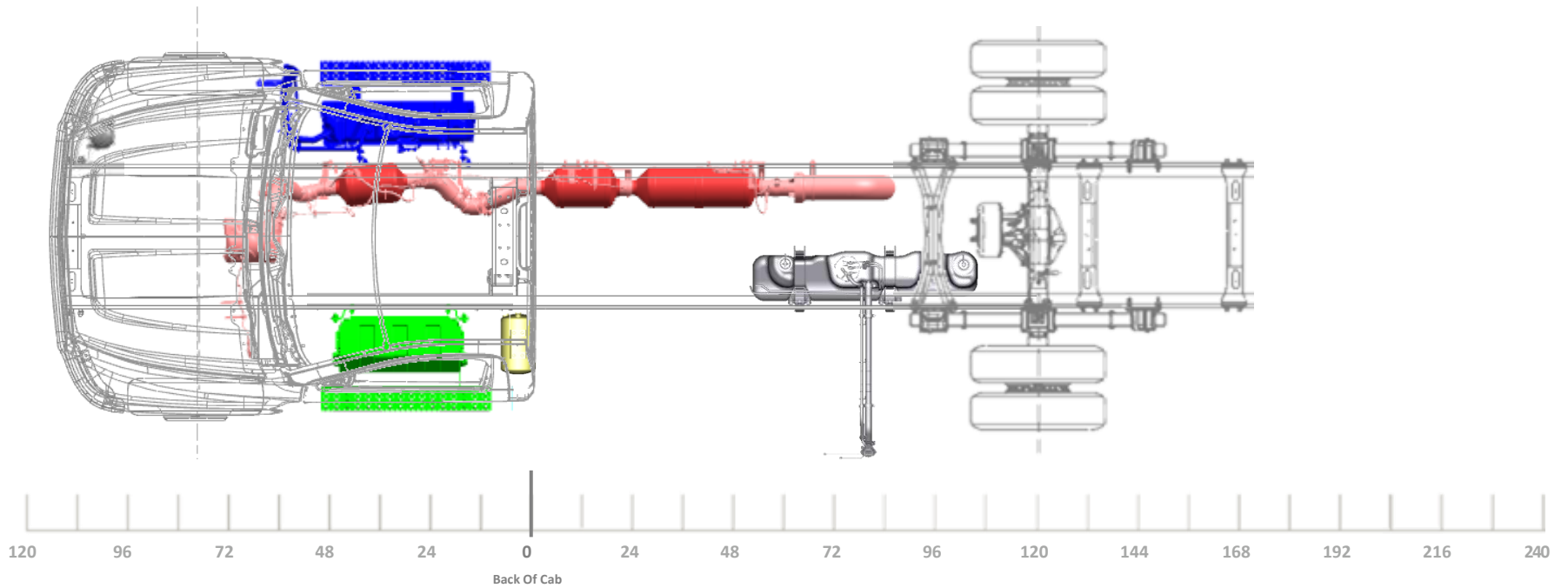

LAST REVISION: 9/25/2023

Model/Feature Information

Model:		C56403 K56403
Cab:		REGULAR CAB
Aftertreatment:		HORIZONTAL
Fuel Tank:	RPO NVK	25 GAL, CA MTD
Battery Box:	RPO 7Y7/7Y8	28" STEEL, 2 BATTERIES
Air Tanks:		(1) OUTSIDE LEFT
DEF Tank:		6.75 GAL
Engine:		6.6L GM DURAMAX

General Configuration Information

4X2 TRUCK CONFIGURATION
REAR AIR SUSPENSION
STRAIGHT TAILPIPE (RPO N12)
OPTIONAL AIR DRYER FWD OUTSIDE RT (RPO KUT/JPY)

Minimum Wheelbase

201" WB (120" CA)
63" OR 75" AF

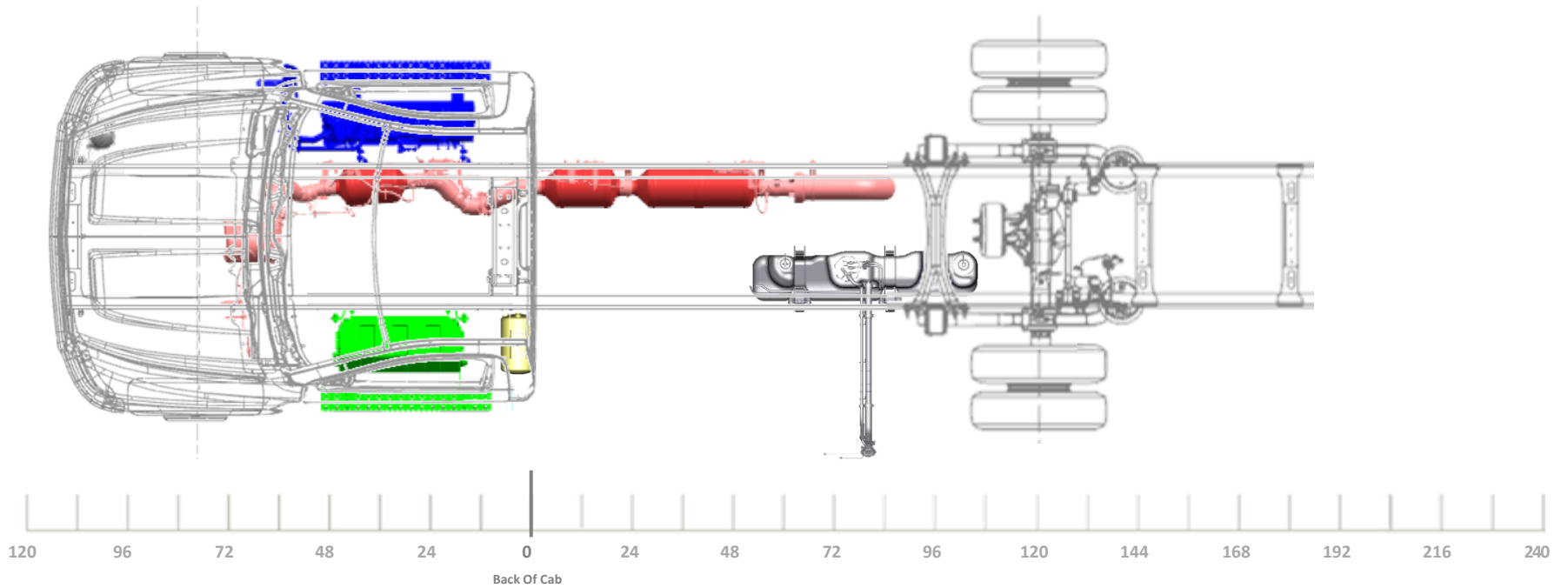

LAST REVISION: 9/25/2023

Model/Feature Information

Model:		C56403 K56403
Cab:		REGULAR CAB
Aftertreatment:		HORIZONTAL
Fuel Tank:	RPO NVK	25 GAL, CA MTD
Battery Box:	RPO 7Y9	TEMP MTD, 3 BATT
Air Tanks:		(1) OUTSIDE LEFT
DEF Tank:		6.75 GAL
Engine:		6.6L GM DURAMAX

General Configuration Information

4X2 OR 4X4 TRUCK CONFIGURATION
 VARI-RATE REAR SUSPENSION

STRAIGHT TAILPIPE (RPO N12)

OPTIONAL AIR DRYER FWD OUTSIDE
 RT (RPO KUT/JPY)

Minimum Wheelbase

201" WB (120" CA)
 49", 63", OR 75" AF

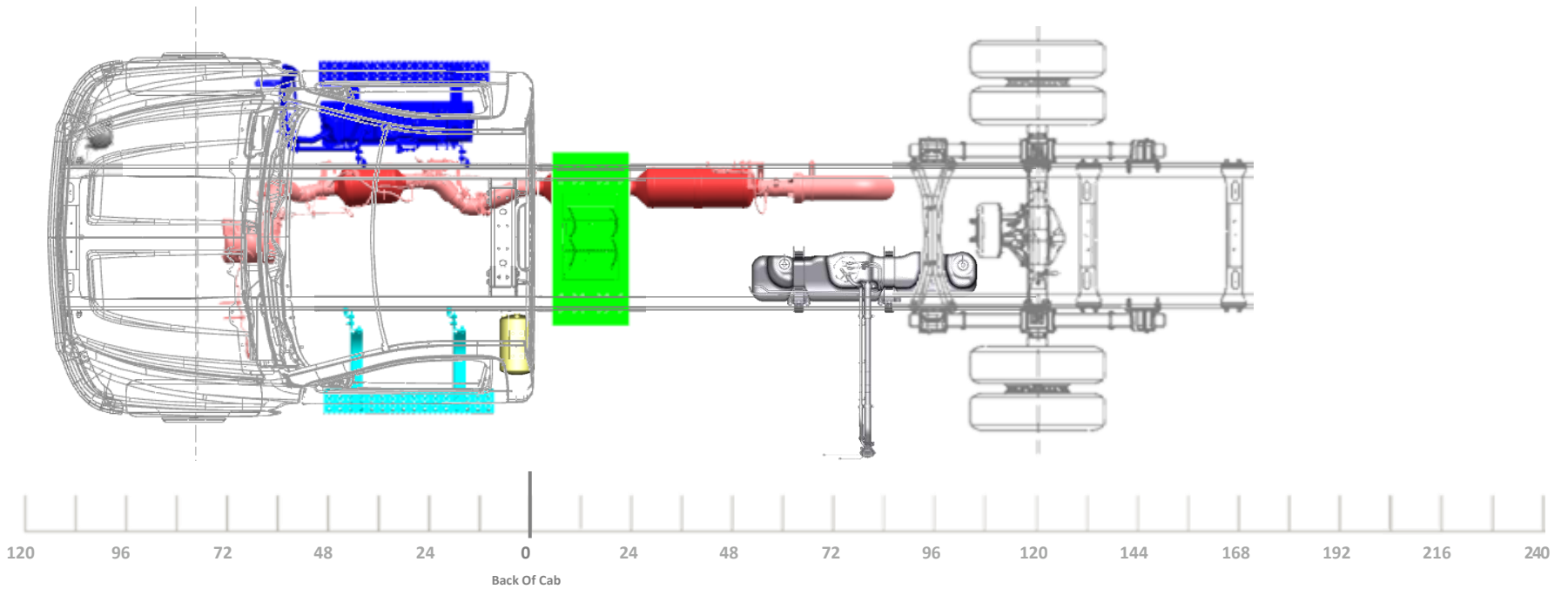

LAST REVISION: 9/25/2023

Model/Feature Information

Model:		C56403 K56403
Cab:		REGULAR CAB
Aftertreatment:		HORIZONTAL
Fuel Tank:	RPO NVK	25 GAL, CA MTD
Battery Box:	RPO 7Y9	TEMP MTD, 3 BATT
Air Tanks:		(1) OUTSIDE LEFT
DEF Tank:		6.75 GAL
Engine:		6.6L GM DURAMAX

General Configuration Information

4X2 TRUCK CONFIGURATION
REAR AIR SUSPENSION
STRAIGHT TAILPIPE (RPO N12)
OPTIONAL AIR DRYER FWD OUTSIDE RT (RPO KUT/JPY)

Minimum Wheelbase

201" WB (120" CA)
63" OR 75" AF

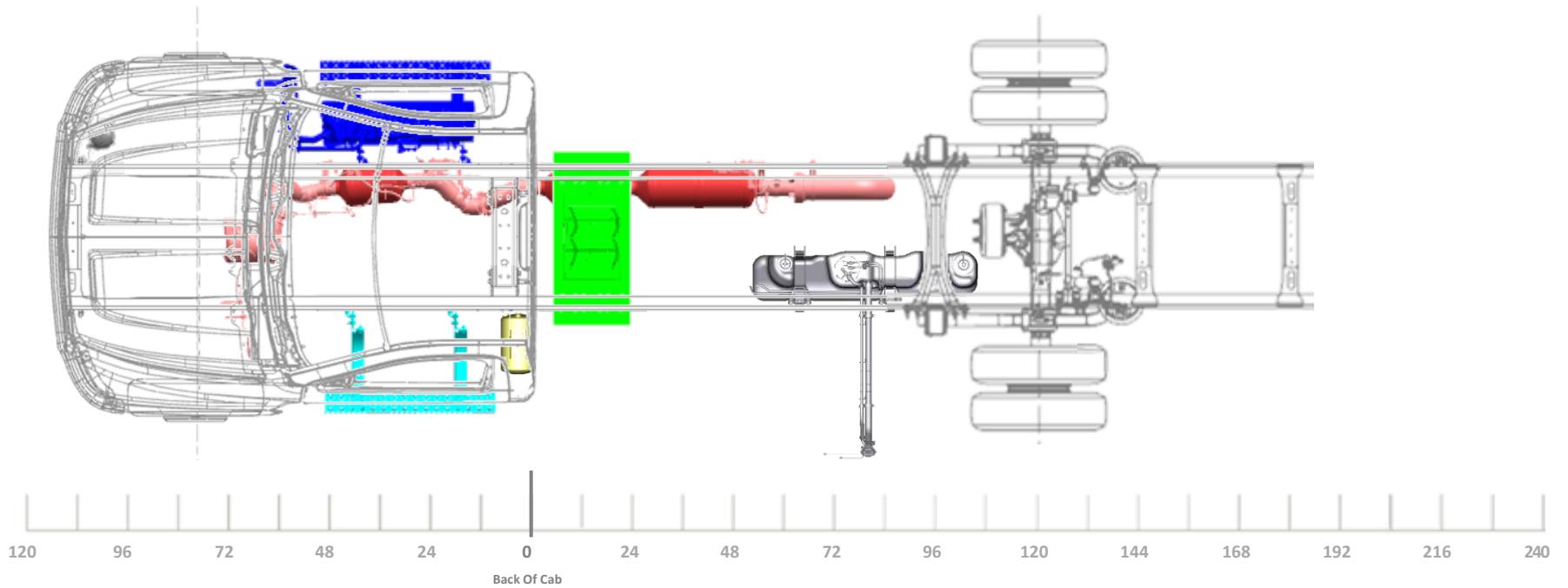

LAST REVISION: 9/25/2023

Model/Feature Information

Model:		C56403 K56403
Cab:		REGULAR CAB
Aftertreatment:		HORIZONTAL
Fuel Tank:	RPO NVK	25 GAL, CA MTD
Battery Box:	RPO 7Y7/7Y8	28" STEEL, 2 BATTERIES
Air Tanks:		(1) OUTSIDE LEFT
DEF Tank:		6.75 GAL
Engine:		6.6L GM DURAMAX

General Configuration Information

4X2 OR 4X4 TRUCK CONFIGURATION
 VARI-RATE REAR SUSPENSION
 SIDE EXIT TAILPIPE AHEAD OF REAR WHEELS, RT SIDE (RPO NPK)
 OPTIONAL AIR DRYER FWD OUTSIDE RT (RPO KUT/JPY)

Minimum Wheelbase

201" WB (120" CA)
 49", 63", OR 75" AF

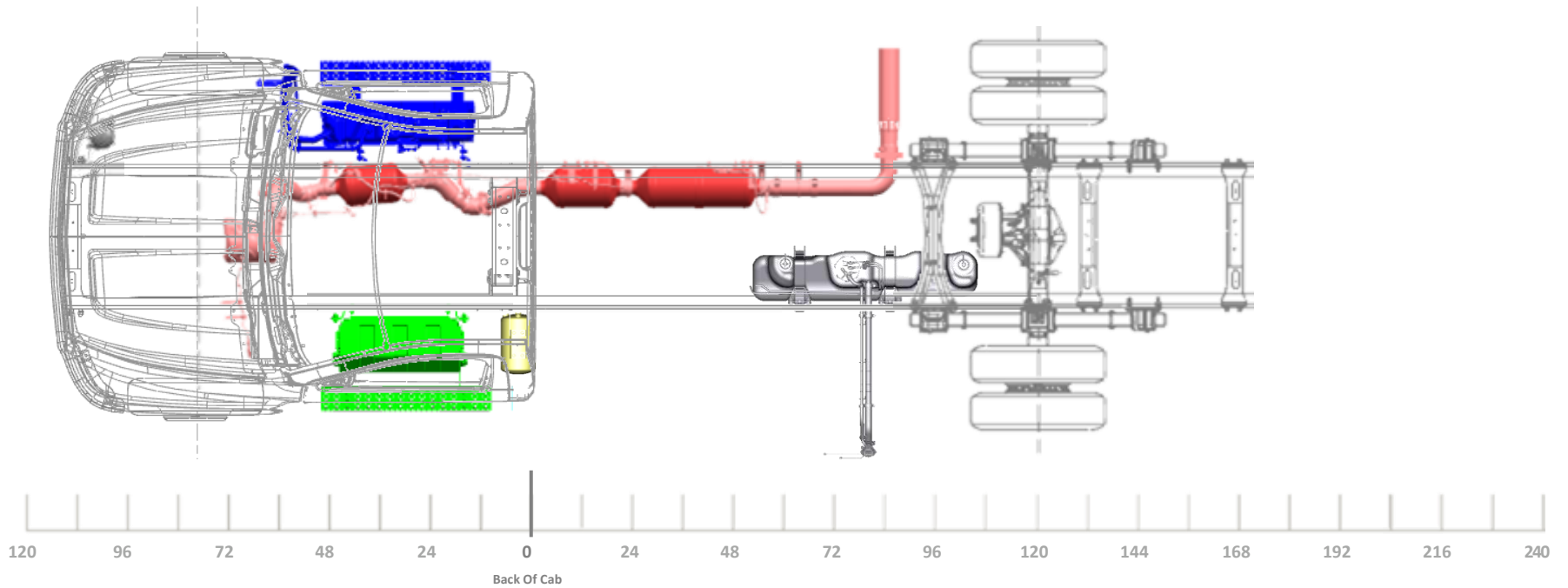

LAST REVISION: 9/25/2023

Model/Feature Information

Model:		C56403 K56403
Cab:		REGULAR CAB
Aftertreatment:		HORIZONTAL
Fuel Tank:	RPO NVK	25 GAL, CA MTD
Battery Box:	RPO 7Y7/7Y8	28" STEEL, 2 BATTERIES
Air Tanks:		(1) OUTSIDE LEFT
DEF Tank:		6.75 GAL
Engine:		6.6L GM DURAMAX

General Configuration Information

4X2 TRUCK CONFIGURATION
REAR AIR SUSPENSION
SIDE EXIT TAILPIPE AHEAD OF REAR WHEELS, RT SIDE (RPO NPK)
OPTIONAL AIR DRYER FWD OUTSIDE RT (RPO KUT/JPY)

Minimum Wheelbase

201" WB (120" CA)
63" OR 75" AF

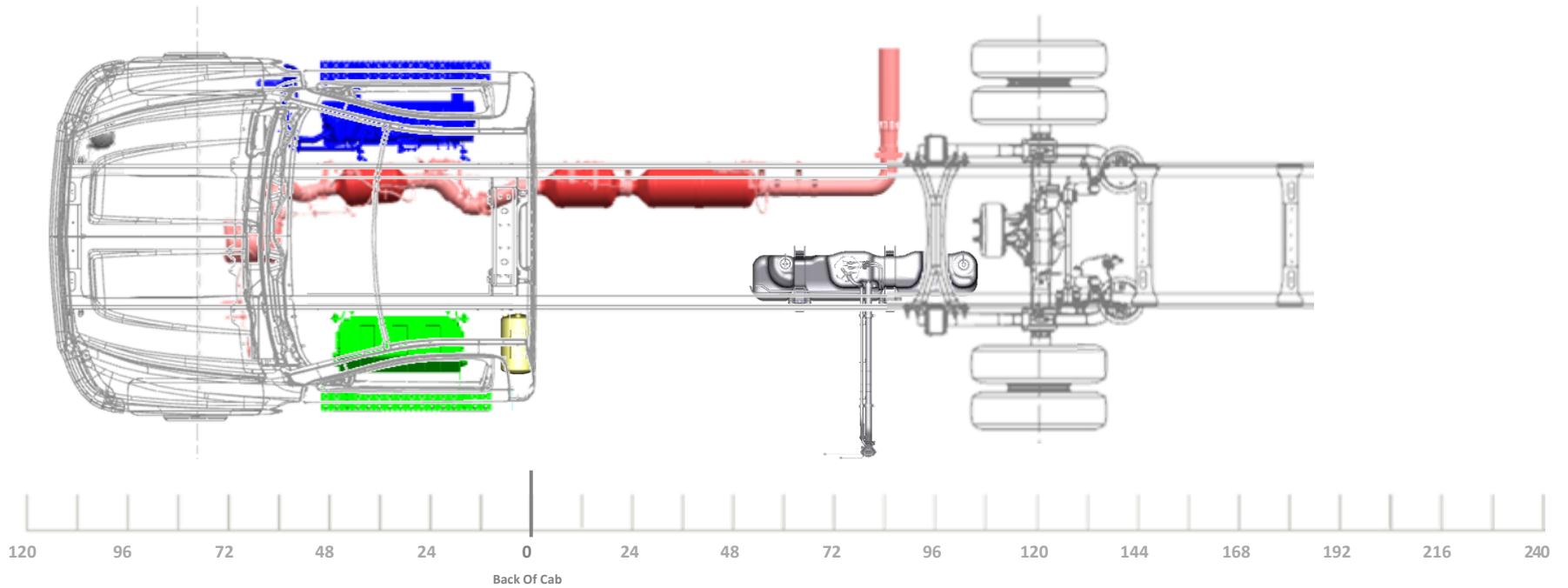

LAST REVISION: 9/25/2023

Model/Feature Information

Model:		C56403 K56403
Cab:		REGULAR CAB
Aftertreatment:		HORIZONTAL
Fuel Tank:	RPO NVK	25 GAL, CA MTD
Battery Box:	RPO 7Y9	TEMP MTD, 3 BATT
Air Tanks:		(1) OUTSIDE LEFT
DEF Tank:		6.75 GAL
Engine:		6.6L GM DURAMAX

General Configuration Information

4X2 OR 4X4 TRUCK CONFIGURATION
 VARI-RATE REAR SUSPENSION

SIDE EXIT TAILPIPE AHEAD OF REAR
 WHEELS, RT SIDE (RPO NPK)

OPTIONAL AIR DRYER FWD OUTSIDE
 RT (RPO KUT/JPY)

Minimum Wheelbase

201" WB (120" CA)
 49", 63", OR 75" AF

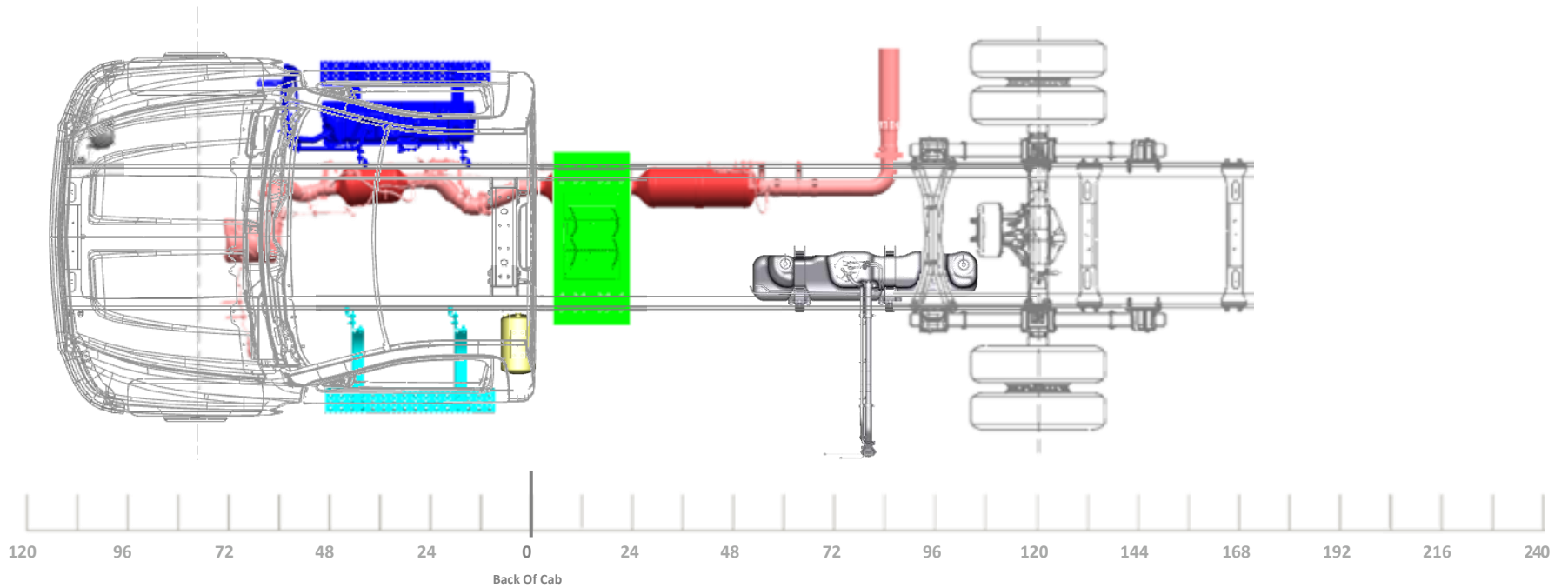

LAST REVISION: 9/25/2023

Model/Feature Information

Model:		C56403 K56403
Cab:		REGULAR CAB
Aftertreatment:		HORIZONTAL
Fuel Tank:	RPO NVK	25 GAL, CA MTD
Battery Box:	RPO 7Y9	TEMP MTD, 3 BATT
Air Tanks:		(1) OUTSIDE LEFT
DEF Tank:		6.75 GAL
Engine:		6.6L GM DURAMAX

General Configuration Information

4X2 TRUCK CONFIGURATION
REAR AIR SUSPENSION
SIDE EXIT TAILPIPE AHEAD OF REAR WHEELS, RT SIDE (RPO NPK)
OPTIONAL AIR DRYER FWD OUTSIDE RT (RPO KUT/JPY)

Minimum Wheelbase

201" WB (120" CA)
63" OR 75" AF

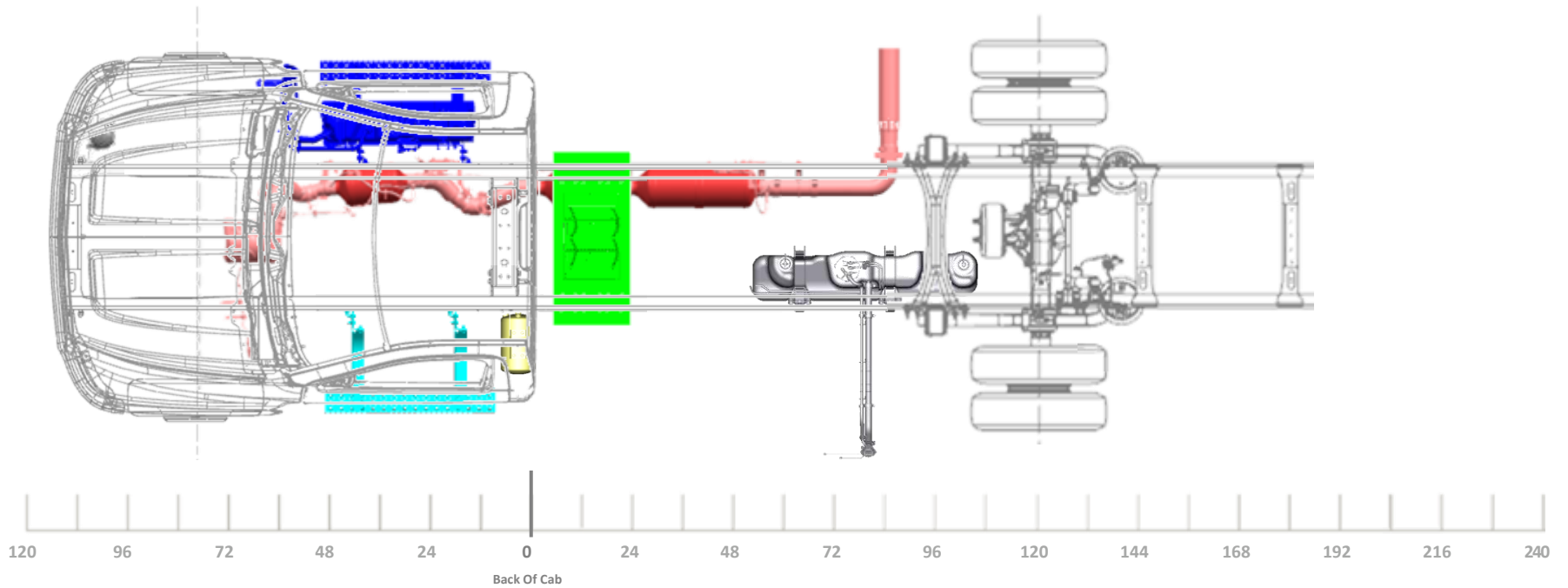

LAST REVISION: 9/25/2023

Model/Feature Information

Model:		C56403 K56403
Cab:		REGULAR CAB
Aftertreatment:		HORIZONTAL
Fuel Tank:	RPO NSQ	DUAL 25G CA, 40G AF
Battery Box:	RPO 7Y7/7Y8	28" STEEL, 2 BATTERIES
Air Tanks:		(1) OUTSIDE LEFT
DEF Tank:		6.75 GAL
Engine:		6.6L GM DURAMAX

General Configuration Information

4X2 OR 4X4 TRUCK CONFIGURATION
 VARI-RATE REAR SUSPENSION

STRAIGHT TAILPIPE (RPO N12)

OPTIONAL AIR DRYER FWD OUTSIDE
 RT (RPO KUT/JPY)

Minimum Wheelbase

201" WB (120" CA)
 49", 63", OR 75" AF

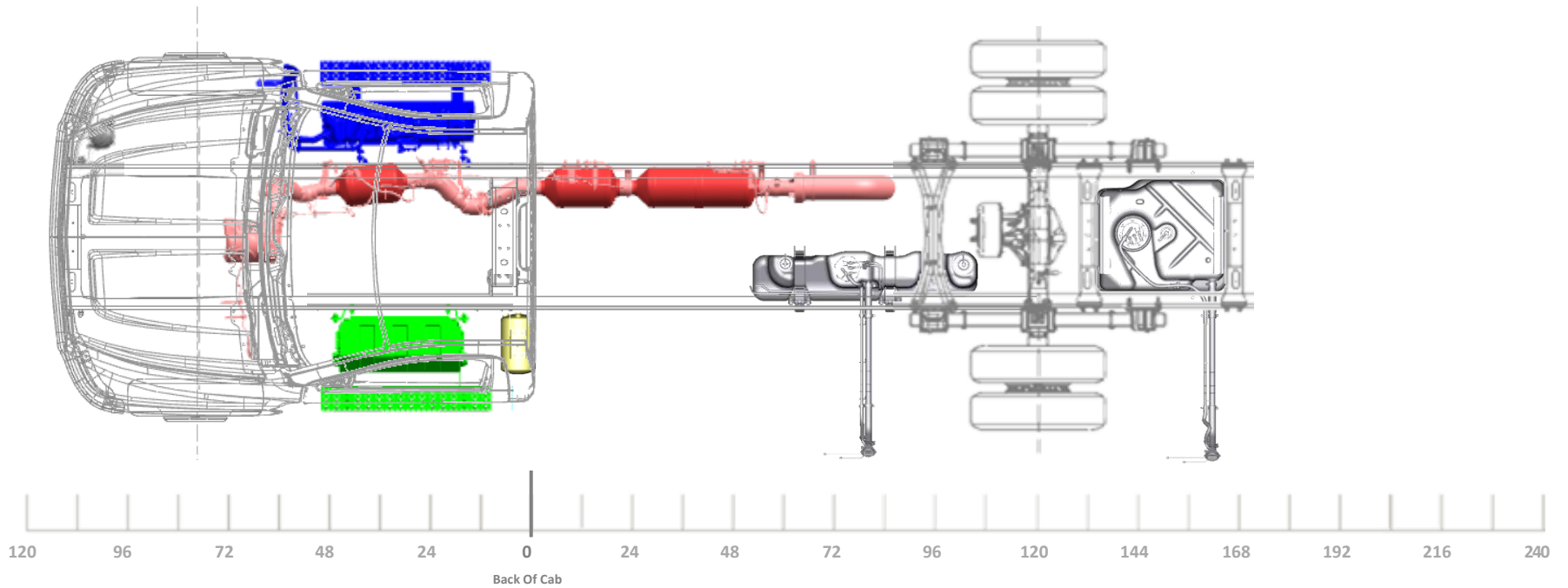

LAST REVISION: 9/25/2023

Model/Feature Information

Model:		C56403 K56403
Cab:		REGULAR CAB
Aftertreatment:		HORIZONTAL
Fuel Tank:	RPO NSQ	DUAL 25G CA, 40G AF
Battery Box:	RPO 7Y7/7Y8	28" STEEL, 2 BATTERIES
Air Tanks:		(1) OUTSIDE LEFT
DEF Tank:		6.75 GAL
Engine:		6.6L GM DURAMAX

General Configuration Information

4X2 TRUCK CONFIGURATION
REAR AIR SUSPENSION
STRAIGHT TAILPIPE (RPO N12)
OPTIONAL AIR DRYER FWD OUTSIDE RT (RPO KUT/JPY)

Minimum Wheelbase

201" WB (120" CA)
63" OR 75" AF

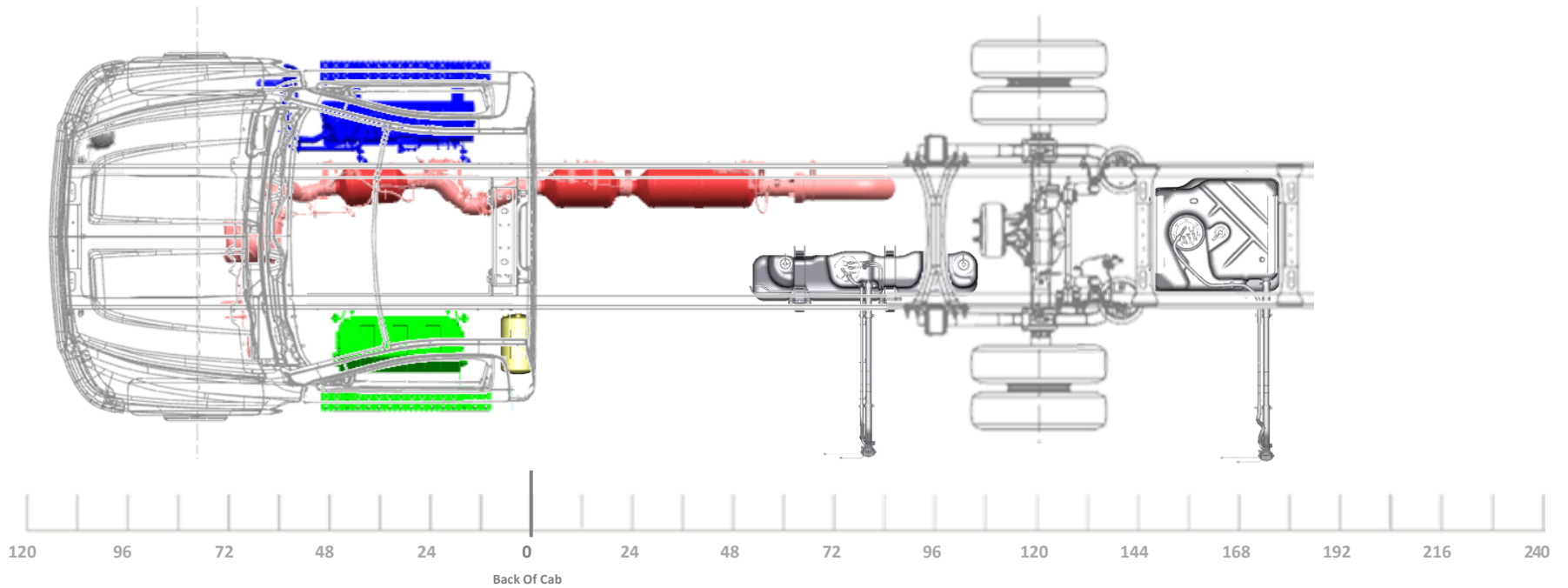

LAST REVISION: 9/25/2023

Model/Feature Information

Model:		C56403 K56403
Cab:		REGULAR CAB
Aftertreatment:		HORIZONTAL
Fuel Tank:	RPO NSQ	DUAL 25G CA, 40G AF
Battery Box:	RPO 7Y9	TEMP MTD, 3 BATT
Air Tanks:		(1) OUTSIDE LEFT
DEF Tank:		6.75 GAL
Engine:		6.6L GM DURAMAX

General Configuration Information

4X2 OR 4X4 TRUCK CONFIGURATION
 VARI-RATE REAR SUSPENSION

STRAIGHT TAILPIPE (RPO N12)

OPTIONAL AIR DRYER FWD OUTSIDE
 RT (RPO KUT/JPY)

Minimum Wheelbase

201" WB (120" CA)
 49", 63", OR 75" AF

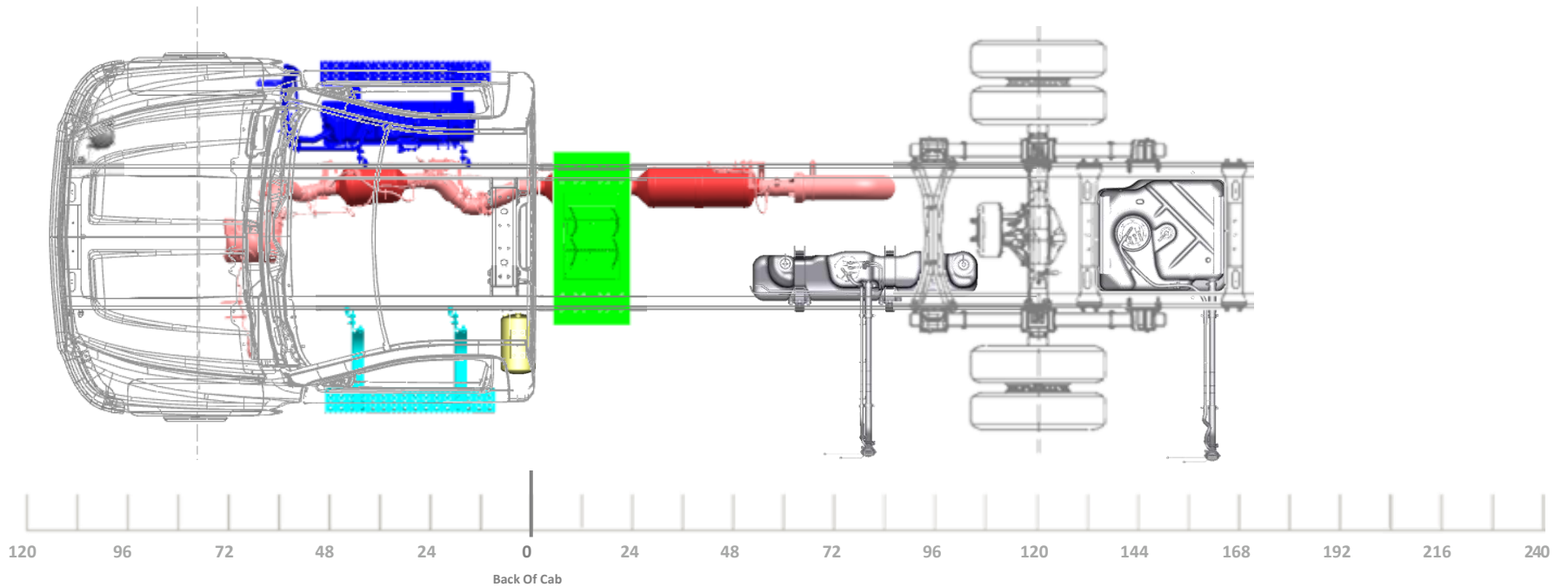

LAST REVISION: 9/25/2023

Model/Feature Information

Model:		C56403 K56403
Cab:		REGULAR CAB
Aftertreatment:		HORIZONTAL
Fuel Tank:	RPO NSQ	DUAL 25G CA, 40G AF
Battery Box:	RPO 7Y9	TEMP MTD, 3 BATT
Air Tanks:		(1) OUTSIDE LEFT
DEF Tank:		6.75 GAL
Engine:		6.6L GM DURAMAX

General Configuration Information

4X2 TRUCK CONFIGURATION
REAR AIR SUSPENSION
STRAIGHT TAILPIPE (RPO N12)
OPTIONAL AIR DRYER FWD OUTSIDE RT (RPO KUT/JPY)

Minimum Wheelbase

201" WB (120" CA)
63" OR 75" AF

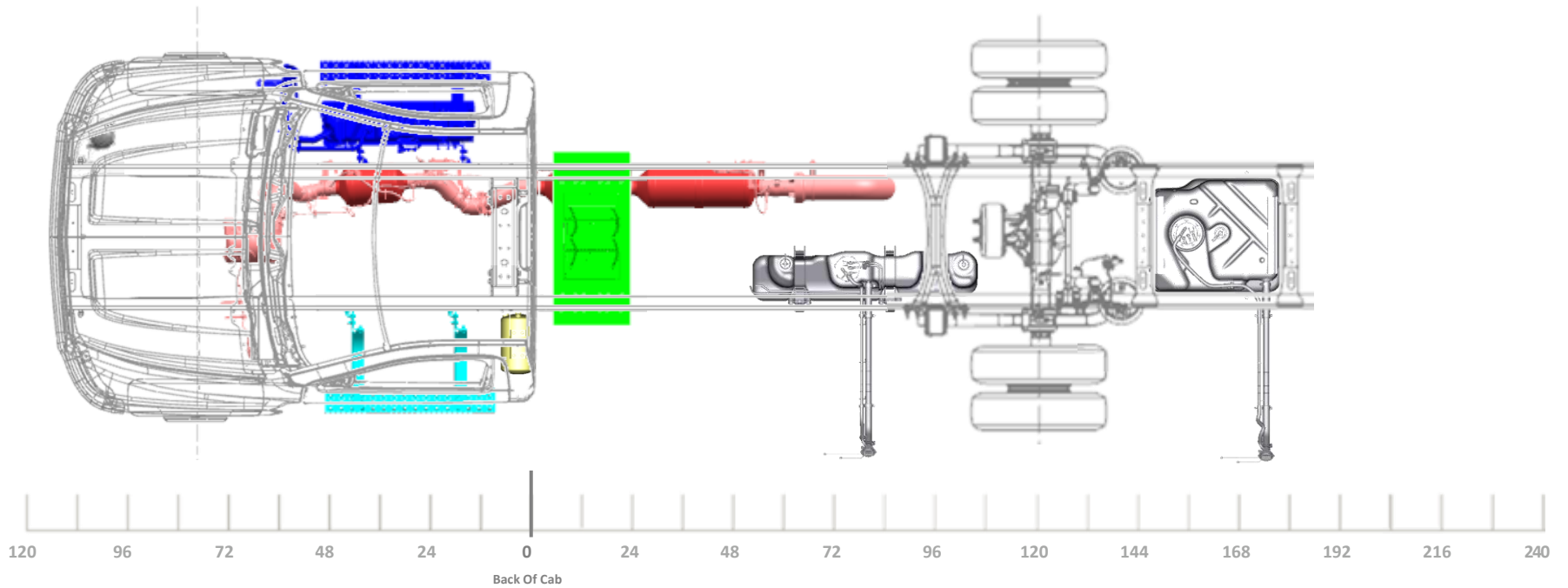

LAST REVISION: 9/25/2023

Model/Feature Information

Model:		C56403 K56403
Cab:		REGULAR CAB
Aftertreatment:		HORIZONTAL
Fuel Tank:	RPO NSQ	DUAL 25G CA, 40G AF
Battery Box:	RPO 7Y7/7Y8	28" STEEL, 2 BATTERIES
Air Tanks:		(1) OUTSIDE LEFT
DEF Tank:		6.75 GAL
Engine:		6.6L GM DURAMAX

General Configuration Information

4X2 OR 4X4 TRUCK CONFIGURATION
 VARI-RATE REAR SUSPENSION

SIDE EXIT TAILPIPE AHEAD OF REAR
 WHEELS, RT SIDE (RPO NPK)

OPTIONAL AIR DRYER FWD OUTSIDE
 RT (RPO KUT/JPY)

Minimum Wheelbase

201" WB (120" CA)
 49", 63", OR 75" AF

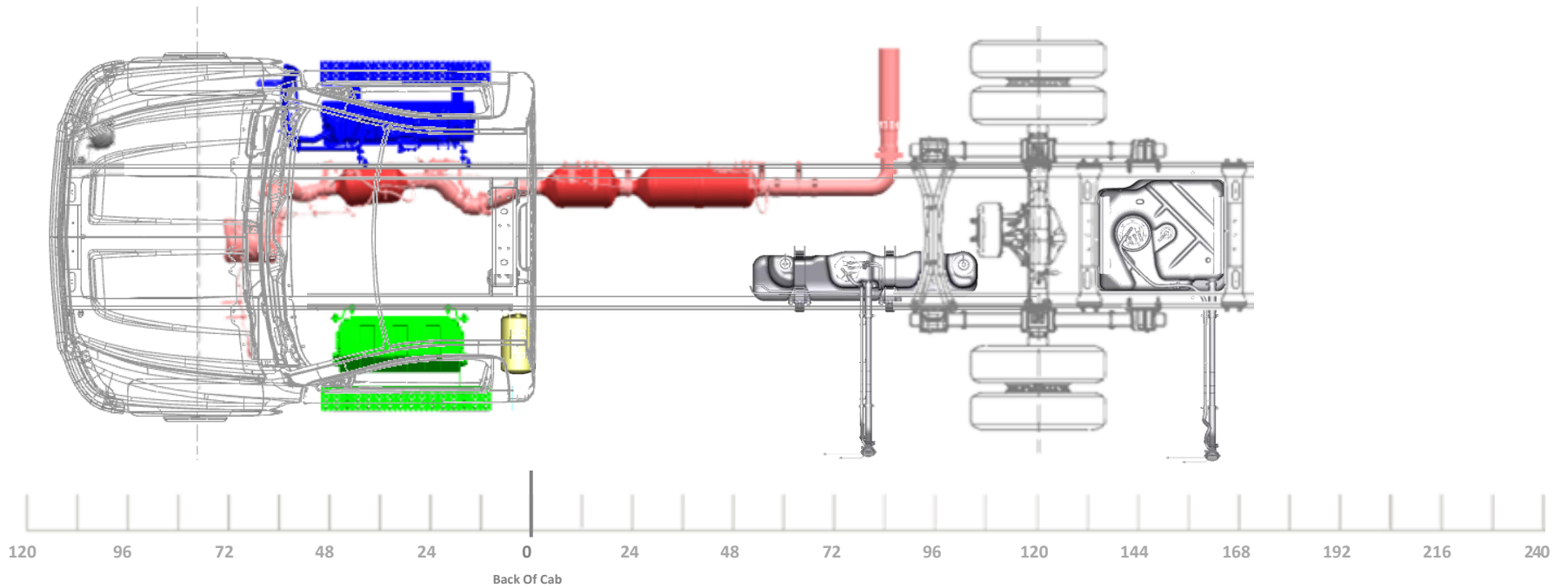

LAST REVISION: 9/25/2023

Model/Feature Information

Model:		C56403 K56403
Cab:		REGULAR CAB
Aftertreatment:		HORIZONTAL
Fuel Tank:	RPO NSQ	DUAL 25G CA, 40G AF
Battery Box:	RPO 7Y7/7Y8	28" STEEL, 2 BATTERIES
Air Tanks:		(1) OUTSIDE LEFT
DEF Tank:		6.75 GAL
Engine:		6.6L GM DURAMAX

General Configuration Information

4X2 TRUCK CONFIGURATION
REAR AIR SUSPENSION
SIDE EXIT TAILPIPE AHEAD OF REAR WHEELS, RT SIDE (RPO NPK)
OPTIONAL AIR DRYER FWD OUTSIDE RT (RPO KUT/JPY)

Minimum Wheelbase

201" WB (120" CA)
63" OR 75" AF

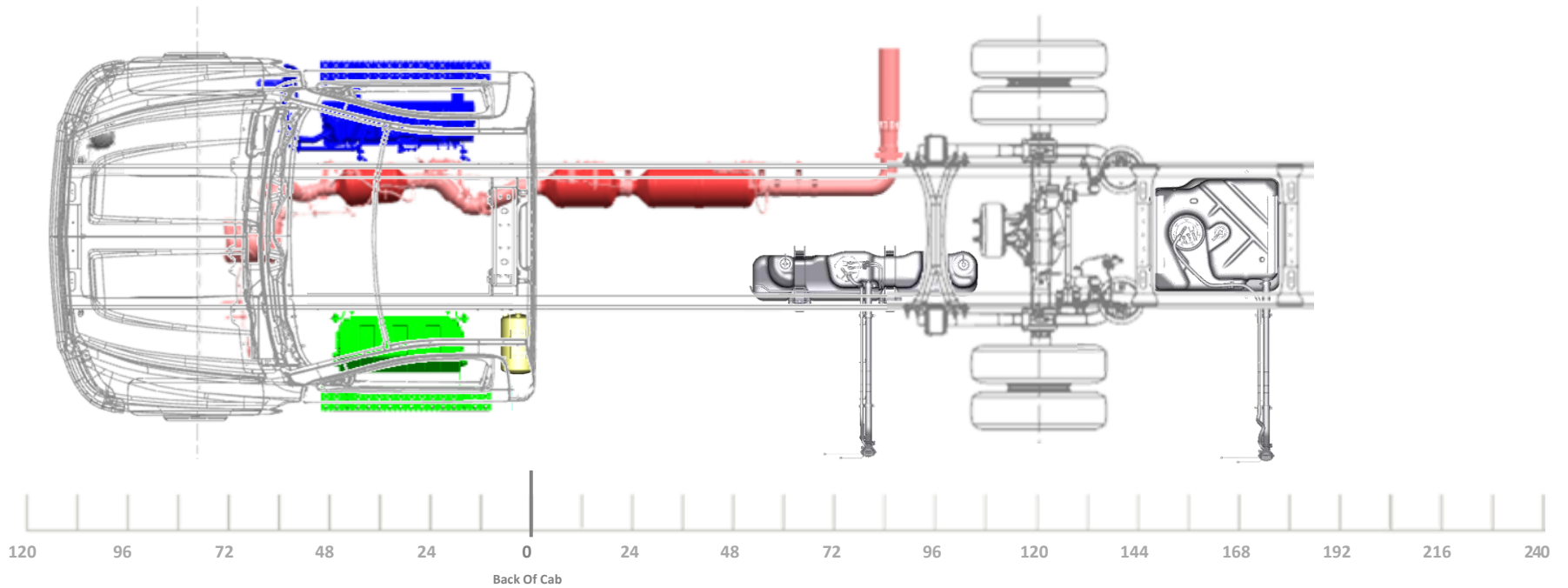

LAST REVISION: 9/25/2023

Model/Feature Information

Model:		C56403 K56403
Cab:		REGULAR CAB
Aftertreatment:		HORIZONTAL
Fuel Tank:	RPO NSQ	DUAL 25G CA, 40G AF
Battery Box:	RPO 7Y9	TEMP MTD, 3 BATT
Air Tanks:		(1) OUTSIDE LEFT
DEF Tank:		6.75 GAL
Engine:		6.6L GM DURAMAX

General Configuration Information

4X2 OR 4X4 TRUCK CONFIGURATION
 VARI-RATE REAR SUSPENSION

SIDE EXIT TAILPIPE AHEAD OF REAR
 WHEELS, RT SIDE (RPO NPK)

OPTIONAL AIR DRYER FWD OUTSIDE
 RT (RPO KUT/JPY)

Minimum Wheelbase

201" WB (120" CA)
 49", 63", OR 75" AF

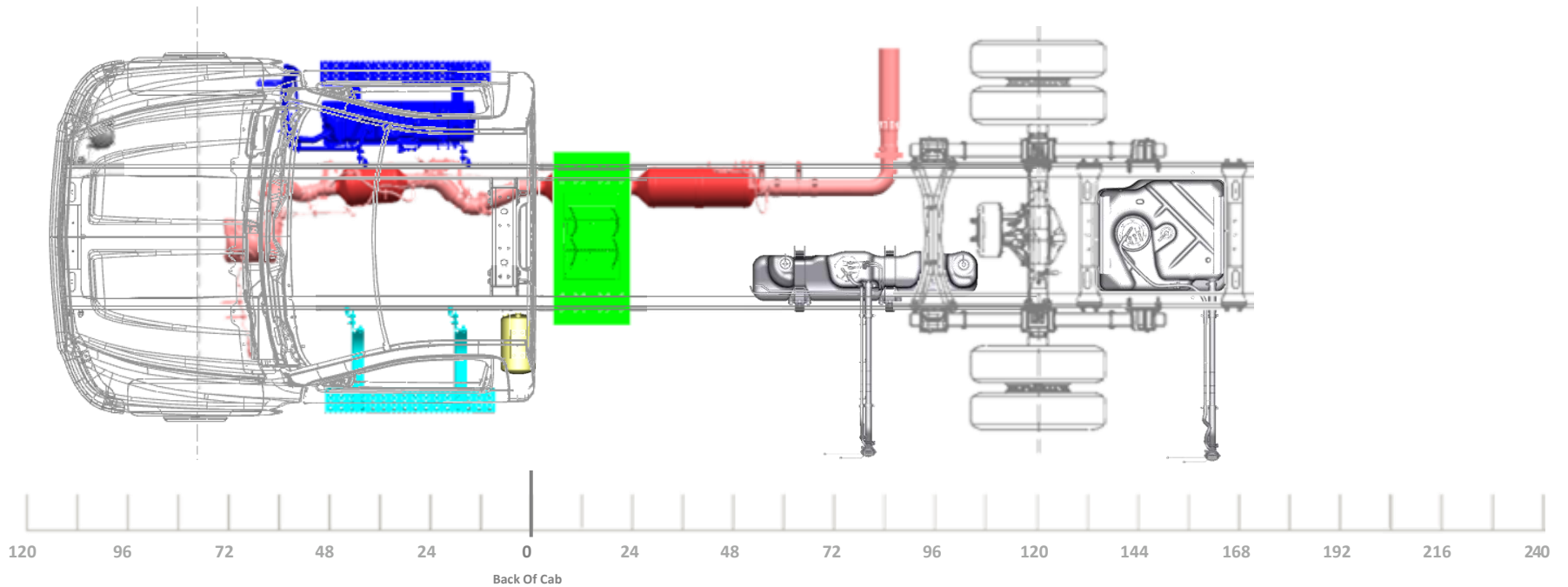

LAST REVISION: 9/25/2023

Model/Feature Information

Model:		C56403 K56403
Cab:		REGULAR CAB
Aftertreatment:		HORIZONTAL
Fuel Tank:	RPO NSQ	DUAL 25G CA, 40G AF
Battery Box:	RPO 7Y9	TEMP MTD, 3 BATT
Air Tanks:		(1) OUTSIDE LEFT
DEF Tank:		6.75 GAL
Engine:		6.6L GM DURAMAX

General Configuration Information

4X2 TRUCK CONFIGURATION
REAR AIR SUSPENSION
SIDE EXIT TAILPIPE AHEAD OF REAR WHEELS, RT SIDE (RPO NPK)
OPTIONAL AIR DRYER FWD OUTSIDE RT (RPO KUT/JPY)

Minimum Wheelbase

201" WB (120" CA)
63" OR 75" AF

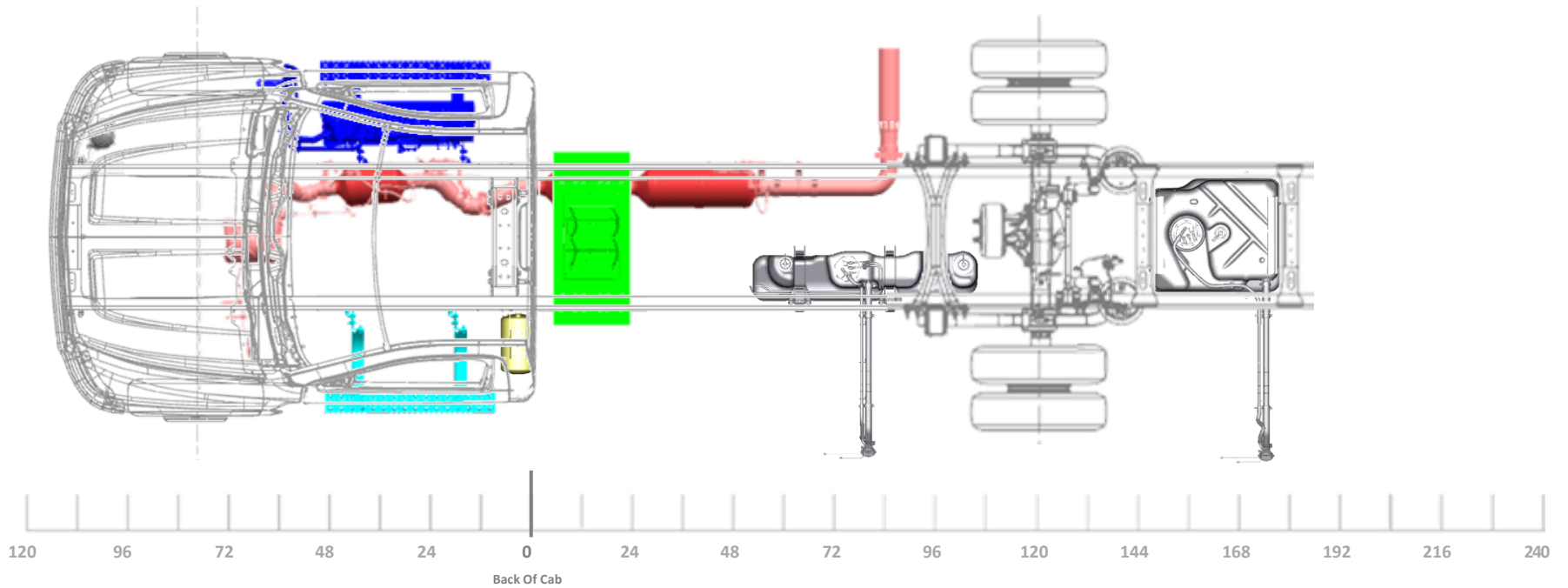

LAST REVISION: 9/25/2023

REGULAR
CAB 219"
WB

Model/Feature Information

Model:		C56403 K56403
Cab:		REGULAR CAB
Aftertreatment:		HORIZONTAL
Fuel Tank:	RPO N2L	40 GAL, AF MTD
Battery Box:	RPO 7Y7/7Y8	28" STEEL, 2 BATTERIES
Air Tanks:		(1) OUTSIDE LEFT
DEF Tank:		6.75 GAL
Engine:		6.6L GM DURAMAX

General Configuration Information

4X2 OR 4X4 TRUCK CONFIGURATION
 VARI-RATE REAR SUSPENSION

STRAIGHT TAILPIPE (RPO N12)

OPTIONAL AIR DRYER FWD OUTSIDE
 RT (RPO KUT/JPY)

Minimum Wheelbase

219" WB (138" CA)
 75" AF

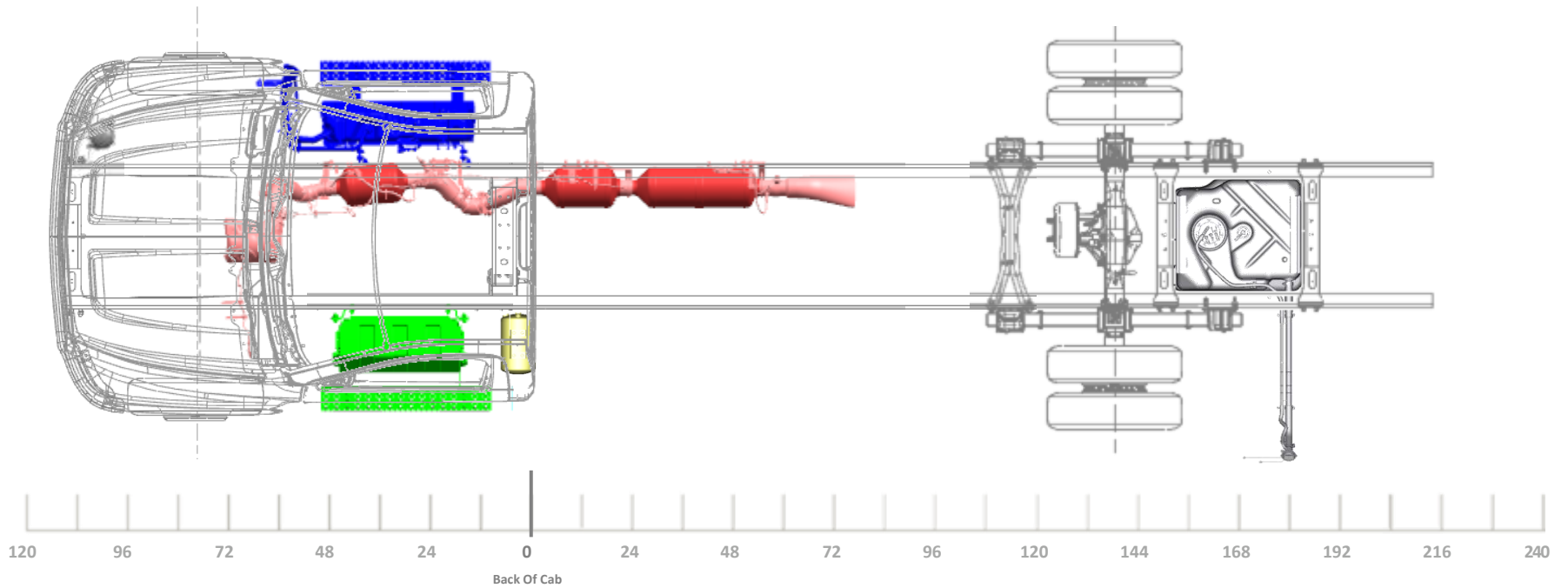

LAST REVISION: 9/25/2023

Model/Feature Information

Model:		C56403 K56403
Cab:		REGULAR CAB
Aftertreatment:		HORIZONTAL
Fuel Tank:	RPO N2L	40 GAL, AF MTD
Battery Box:	RPO 7Y7/7Y8	28" STEEL, 2 BATTERIES
Air Tanks:		(1) OUTSIDE LEFT
DEF Tank:		6.75 GAL
Engine:		6.6L GM DURAMAX

General Configuration Information

4X2 TRUCK CONFIGURATION
REAR AIR SUSPENSION
STRAIGHT TAILPIPE (RPO N12)
OPTIONAL AIR DRYER FWD OUTSIDE RT (RPO KUT/JPY)

Minimum Wheelbase

219" WB (138" CA)
75" AF

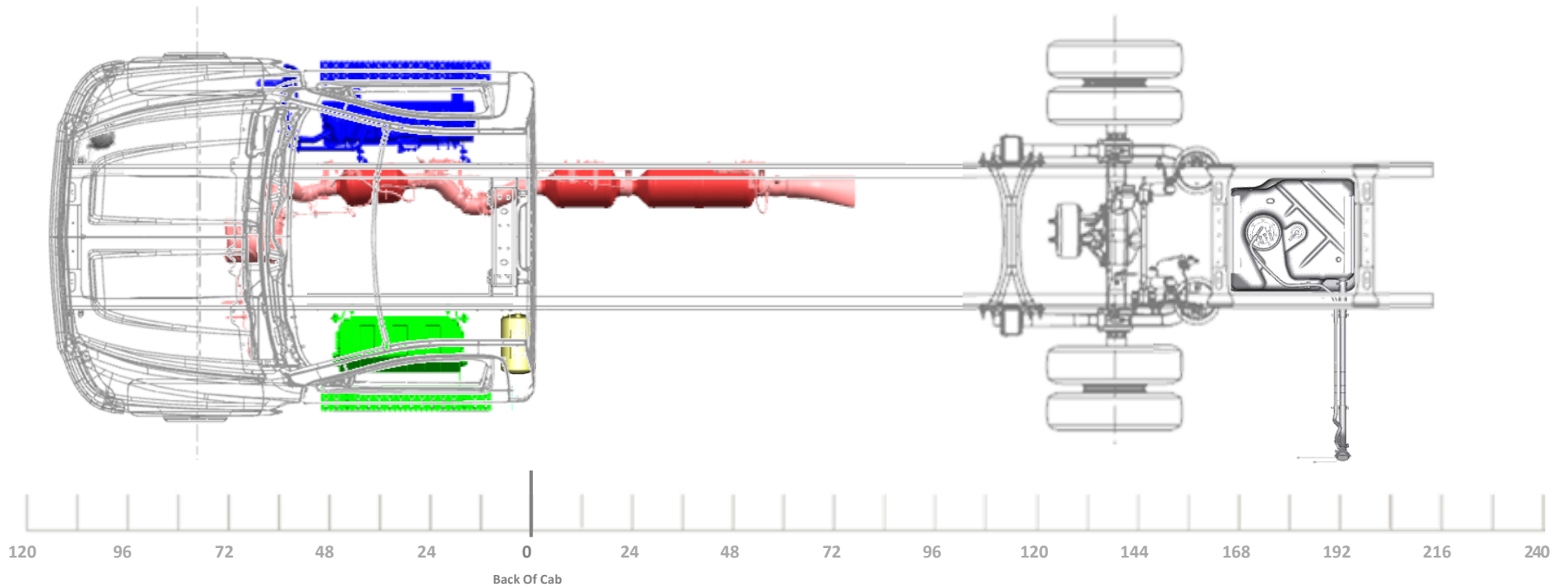

LAST REVISION: 9/25/2023

Model/Feature Information

Model:		C56403 K56403
Cab:		REGULAR CAB
Aftertreatment:		HORIZONTAL
Fuel Tank:	RPO N2L	40 GAL, AF MTD
Battery Box:	RPO 7Y9	TEMP MTD, 3 BATT
Air Tanks:		(1) OUTSIDE LEFT
DEF Tank:		6.75 GAL
Engine:		6.6L GM DURAMAX

General Configuration Information

4X2 OR 4X4 TRUCK CONFIGURATION
 VARI-RATE REAR SUSPENSION

STRAIGHT TAILPIPE (RPO N12)

OPTIONAL AIR DRYER FWD OUTSIDE
 RT (RPO KUT/JPY)

Minimum Wheelbase

219" WB (138" CA)
 75" AF

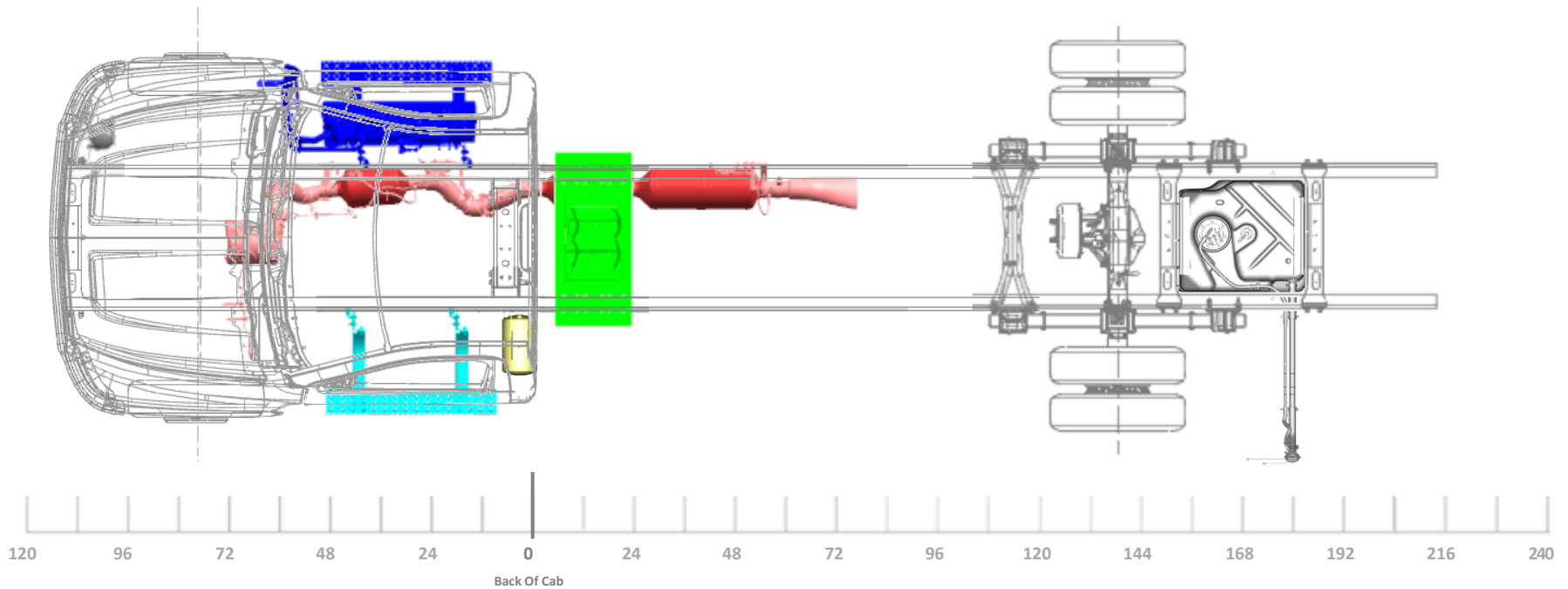

LAST REVISION: 9/25/2023

Model/Feature Information

Model:		C56403 K56403
Cab:		REGULAR CAB
Aftertreatment:		HORIZONTAL
Fuel Tank:	RPO N2L	40 GAL, AF MTD
Battery Box:	RPO 7Y9	TEMP MTD, 3 BATT
Air Tanks:		(1) OUTSIDE LEFT
DEF Tank:		6.75 GAL
Engine:		6.6L GM DURAMAX

General Configuration Information

4X2 TRUCK CONFIGURATION
REAR AIR SUSPENSION
STRAIGHT TAILPIPE (RPO N12)
OPTIONAL AIR DRYER FWD OUTSIDE RT (RPO KUT/JPY)

Minimum Wheelbase

219" WB (138" CA)
75" AF

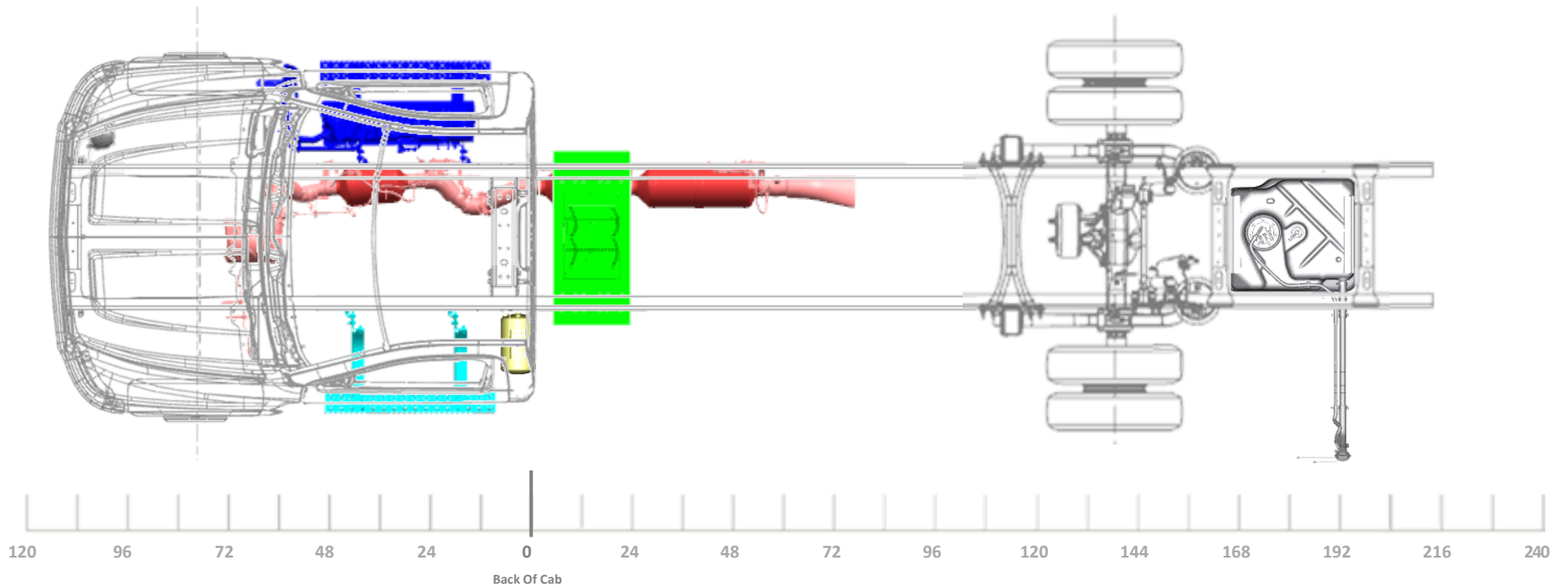

LAST REVISION: 9/25/2023

Model/Feature Information

Model:		C56403 K56403
Cab:		REGULAR CAB
Aftertreatment:		HORIZONTAL
Fuel Tank:	RPO N2L	40 GAL, AF MTD
Battery Box:	RPO 7Y7/7Y8	28" STEEL, 2 BATTERIES
Air Tanks:		(1) OUTSIDE LEFT
DEF Tank:		6.75 GAL
Engine:		6.6L GM DURAMAX

General Configuration Information

4X2 OR 4X4 TRUCK CONFIGURATION
 VARI-RATE REAR SUSPENSION

SIDE EXIT TAILPIPE AHEAD OF REAR
 WHEELS, LT SIDE (RPO NPJ)

OPTIONAL AIR DRYER FWD OUTSIDE
 RT (RPO KUT/JPY)

Minimum Wheelbase

219" WB (138" CA)
 75" AF

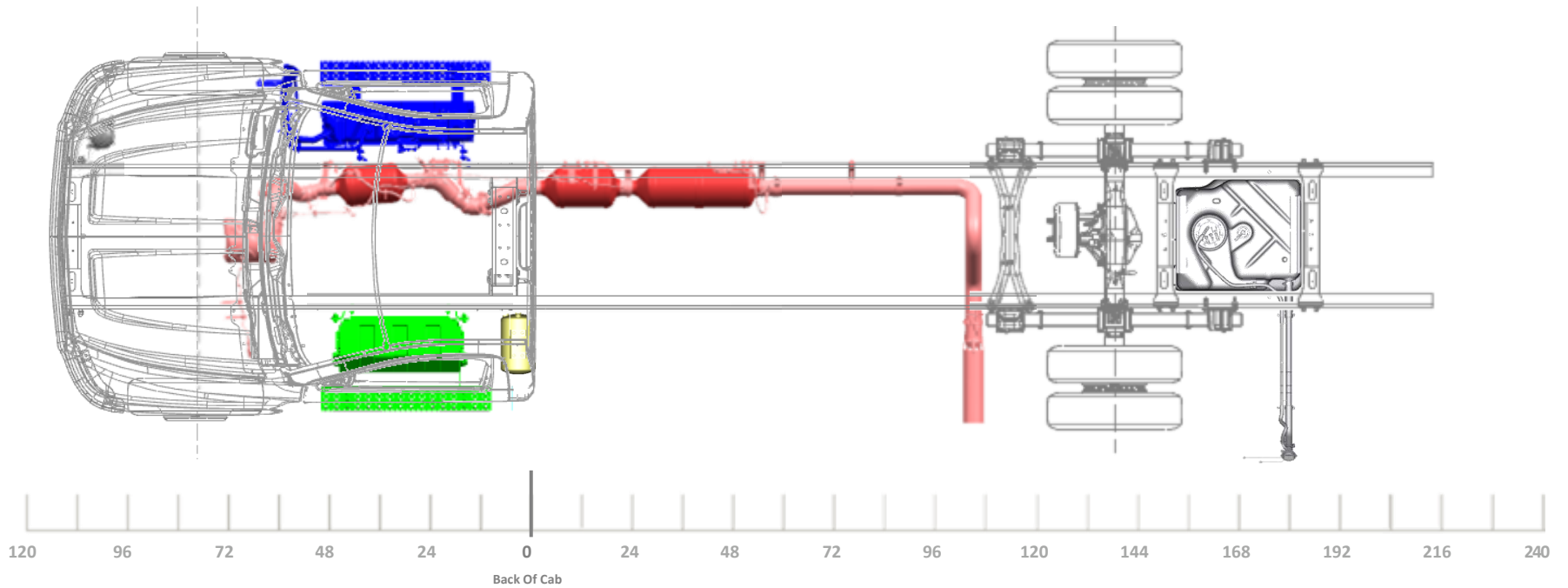

LAST REVISION: 9/25/2023

Model/Feature Information

Model:		C56403 K56403
Cab:		REGULAR CAB
Aftertreatment:		HORIZONTAL
Fuel Tank:	RPO N2L	40 GAL, AF MTD
Battery Box:	RPO 7Y7/7Y8	28" STEEL, 2 BATTERIES
Air Tanks:		(1) OUTSIDE LEFT
DEF Tank:		6.75 GAL
Engine:		6.6L GM DURAMAX

General Configuration Information

4X2 TRUCK CONFIGURATION
REAR AIR SUSPENSION
SIDE EXIT TAILPIPE AHEAD OF REAR WHEELS, LT SIDE (RPO NPJ)
OPTIONAL AIR DRYER FWD OUTSIDE RT (RPO KUT/JPY)

Minimum Wheelbase

219" WB (138" CA)
75" AF

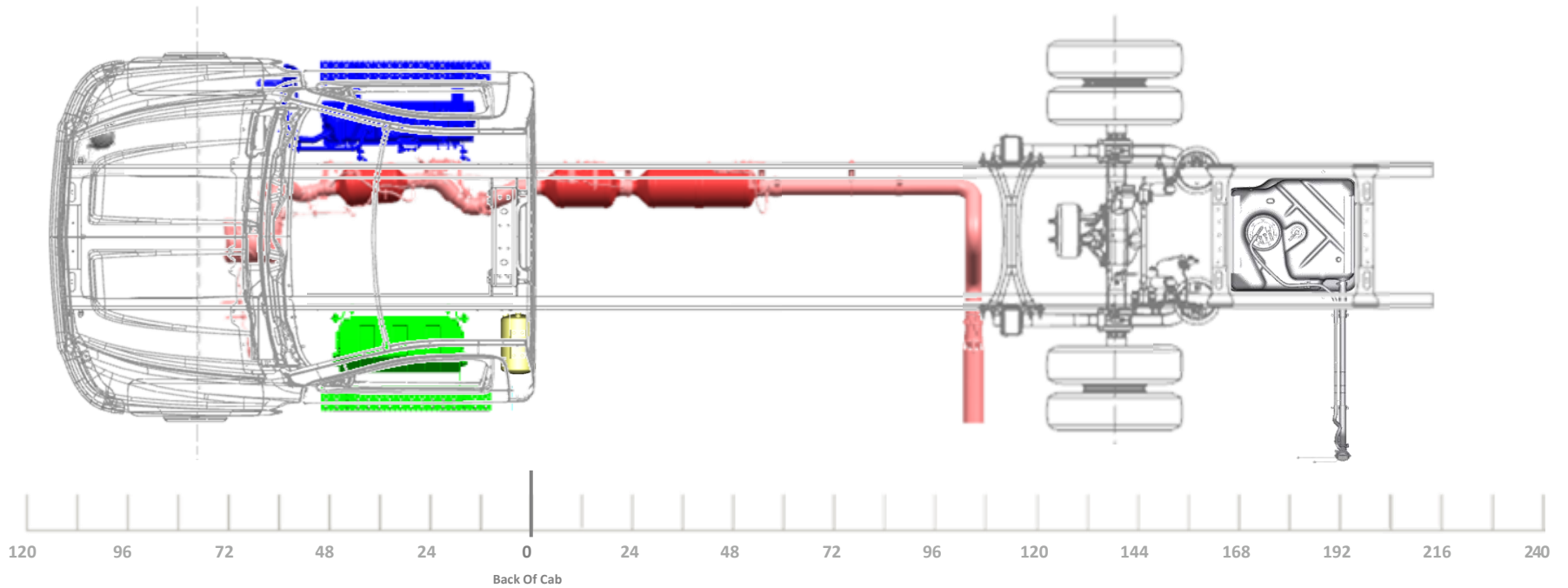

LAST REVISION: 9/25/2023

Model/Feature Information

Model:		C56403 K56403
Cab:		REGULAR CAB
Aftertreatment:		HORIZONTAL
Fuel Tank:	RPO N2L	40 GAL, AF MTD
Battery Box:	RPO 7Y9	TEMP MTD, 3 BATT
Air Tanks:		(1) OUTSIDE LEFT
DEF Tank:		6.75 GAL
Engine:		6.6L GM DURAMAX

General Configuration Information

4X2 OR 4X4 TRUCK CONFIGURATION
 VARI-RATE REAR SUSPENSION

SIDE EXIT TAILPIPE AHEAD OF REAR
 WHEELS, LT SIDE (RPO NPJ)

OPTIONAL AIR DRYER FWD OUTSIDE
 RT (RPO KUT/JPY)

Minimum Wheelbase

219" WB (138" CA)
 75" AF

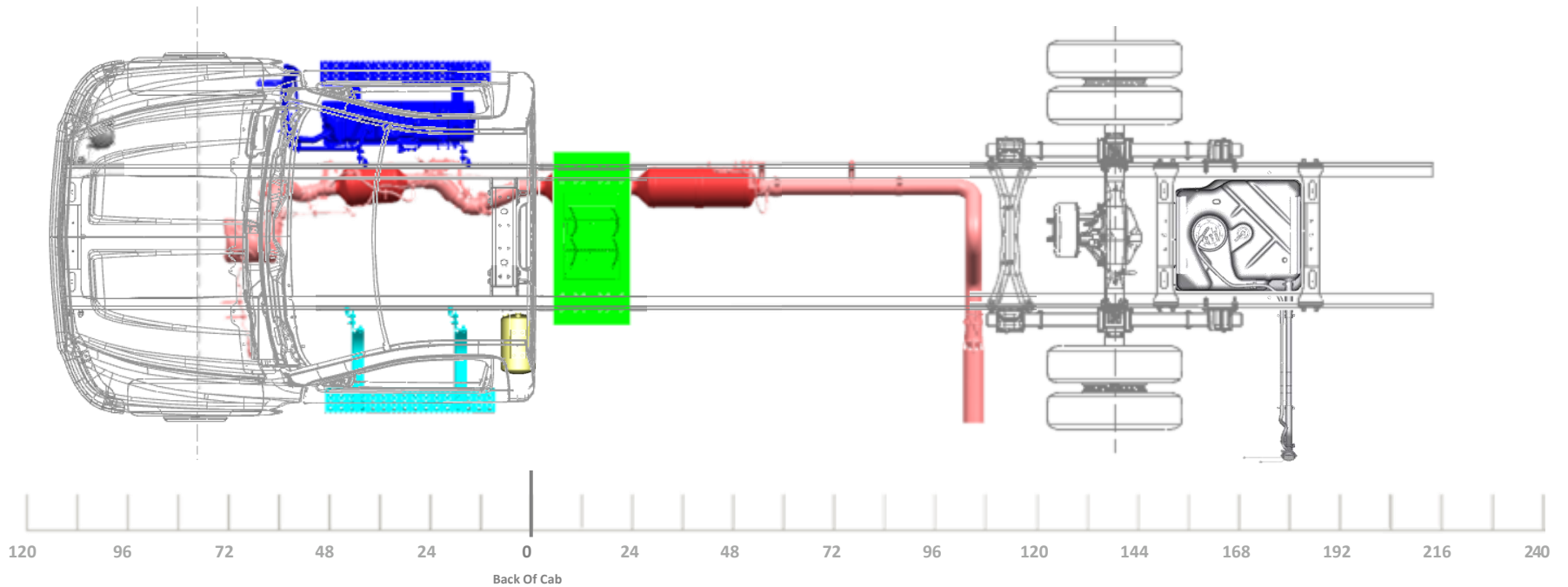

LAST REVISION: 9/25/2023

Model/Feature Information

Model:		C56403 K56403
Cab:		REGULAR CAB
Aftertreatment:		HORIZONTAL
Fuel Tank:	RPO N2L	40 GAL, AF MTD
Battery Box:	RPO 7Y9	TEMP MTD, 3 BATT
Air Tanks:		(1) OUTSIDE LEFT
DEF Tank:		6.75 GAL
Engine:		6.6L GM DURAMAX

General Configuration Information

4X2 TRUCK CONFIGURATION
 REAR AIR SUSPENSION
 SIDE EXIT TAILPIPE AHEAD OF REAR WHEELS, LT SIDE (RPO NPJ)
 OPTIONAL AIR DRYER FWD OUTSIDE RT (RPO KUT/JPY)

Minimum Wheelbase

219" WB (138" CA)
 75" AF

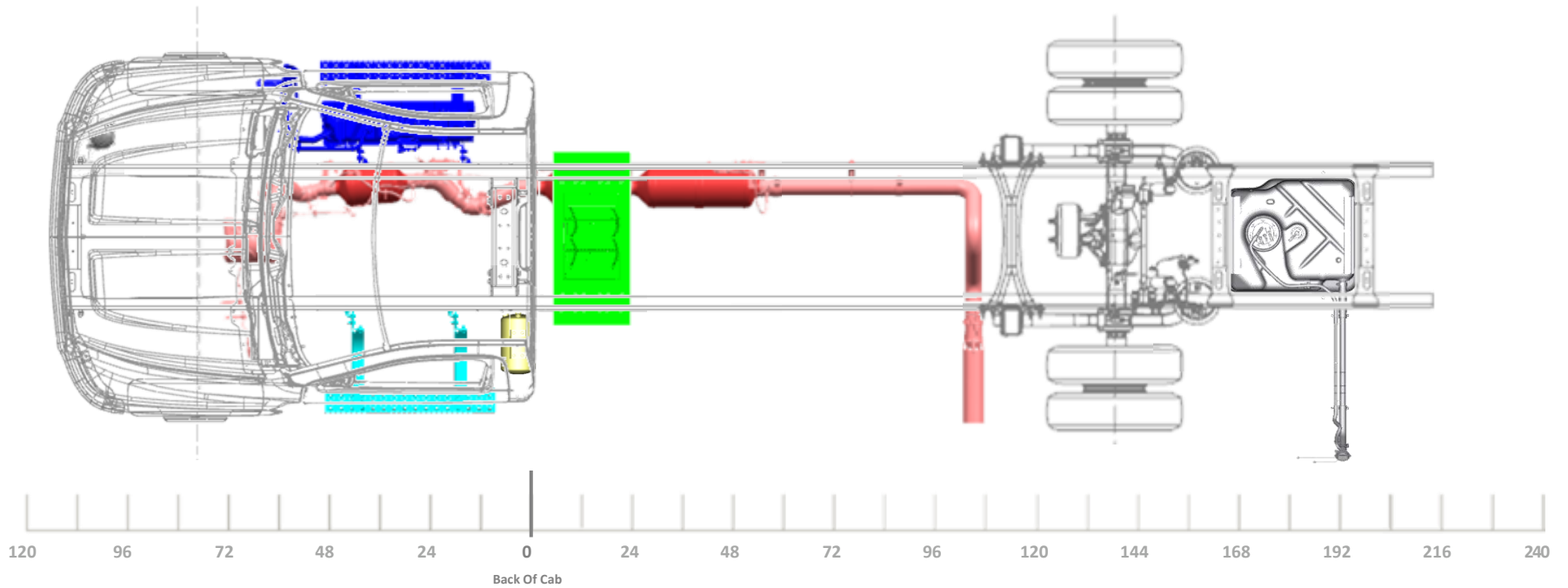

LAST REVISION: 9/25/2023

Model/Feature Information

Model:		C56403 K56403
Cab:		REGULAR CAB
Aftertreatment:		HORIZONTAL
Fuel Tank:	RPO N2L	40 GAL, AF MTD
Battery Box:	RPO 7Y7/7Y8	28" STEEL, 2 BATTERIES
Air Tanks:		(1) OUTSIDE LEFT
DEF Tank:		6.75 GAL
Engine:		6.6L GM DURAMAX

General Configuration Information

4X2 OR 4X4 TRUCK CONFIGURATION
VARI-RATE REAR SUSPENSION

SIDE EXIT TAILPIPE AHEAD OF REAR
WHEELS, RT SIDE (RPO NPK)

OPTIONAL AIR DRYER FWD OUTSIDE
RT (RPO KUT/JPY)

Minimum Wheelbase

219" WB (138" CA)
75" AF

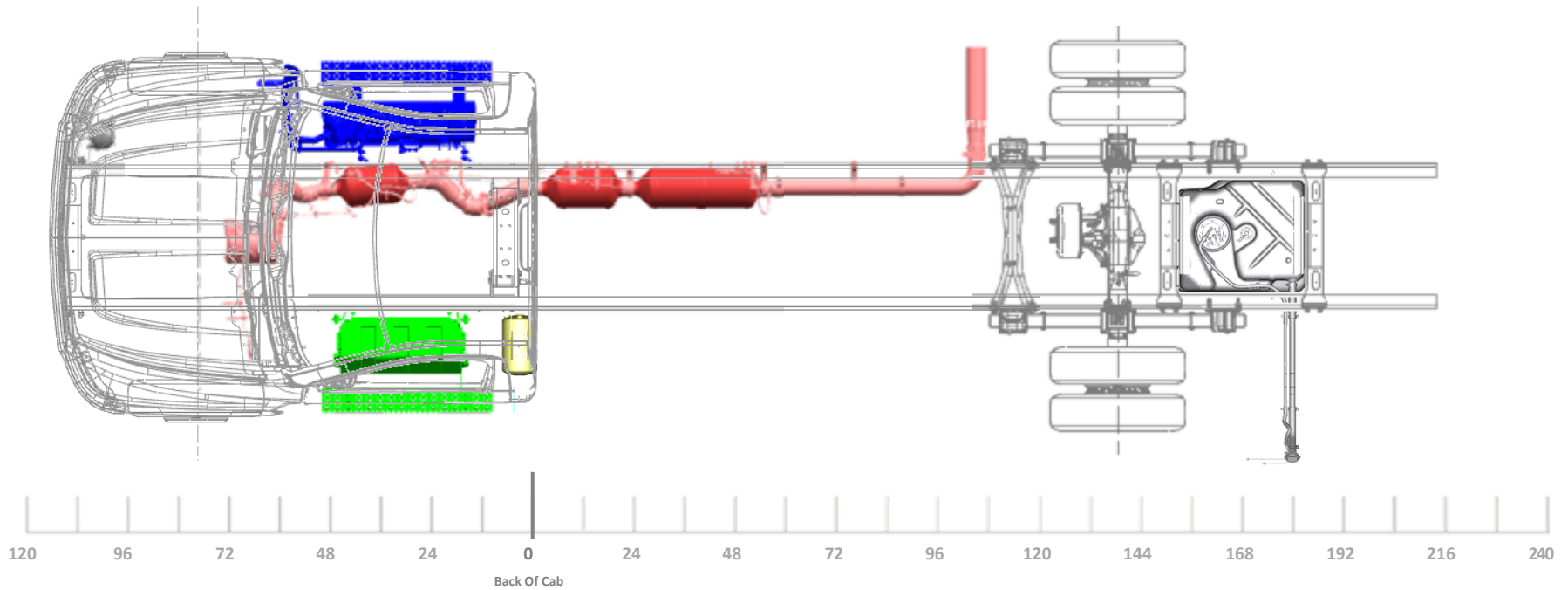

LAST REVISION: 9/25/2023

Model/Feature Information

Model:		C56403 K56403
Cab:		REGULAR CAB
Aftertreatment:		HORIZONTAL
Fuel Tank:	RPO N2L	40 GAL, AF MTD
Battery Box:	RPO 7Y7/7Y8	28" STEEL, 2 BATTERIES
Air Tanks:		(1) OUTSIDE LEFT
DEF Tank:		6.75 GAL
Engine:		6.6L GM DURAMAX

General Configuration Information

4X2 TRUCK CONFIGURATION
REAR AIR SUSPENSION
SIDE EXIT TAILPIPE AHEAD OF REAR WHEELS, RT SIDE (RPO NPK)
OPTIONAL AIR DRYER FWD OUTSIDE RT (RPO KUT/JPY)

Minimum Wheelbase

219" WB (138" CA)
75" AF

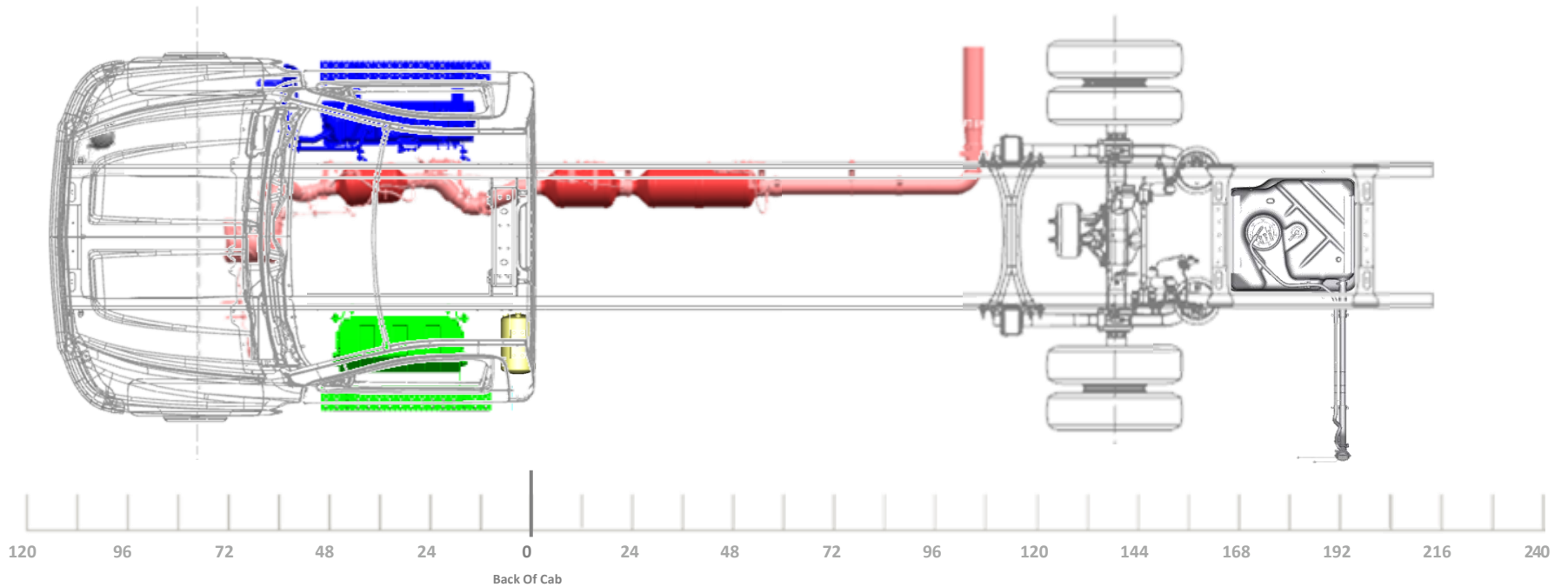

LAST REVISION: 9/25/2023

Model/Feature Information

Model:		C56403 K56403
Cab:		REGULAR CAB
Aftertreatment:		HORIZONTAL
Fuel Tank:	RPO N2L	40 GAL, AF MTD
Battery Box:	RPO 7Y9	TEMP MTD, 3 BATT
Air Tanks:		(1) OUTSIDE LEFT
DEF Tank:		6.75 GAL
Engine:		6.6L GM DURAMAX

General Configuration Information

4X2 OR 4X4 TRUCK CONFIGURATION
 VARI-RATE REAR SUSPENSION

SIDE EXIT TAILPIPE AHEAD OF REAR
 WHEELS, RT SIDE (RPO NPK)

OPTIONAL AIR DRYER FWD OUTSIDE
 RT (RPO KUT/JPY)

Minimum Wheelbase

219" WB (138" CA)
 75" AF

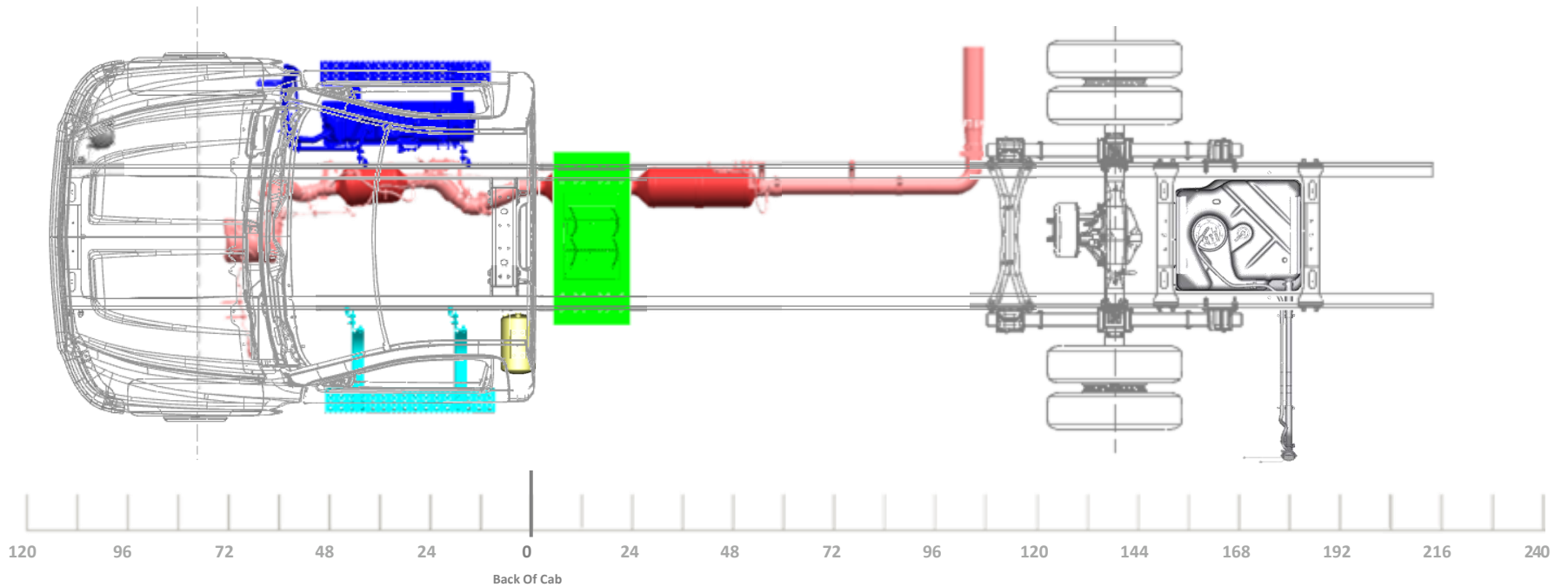

LAST REVISION: 9/25/2023

Model/Feature Information

Model:		C56403 K56403
Cab:		REGULAR CAB
Aftertreatment:		HORIZONTAL
Fuel Tank:	RPO N2L	40 GAL, AF MTD
Battery Box:	RPO 7Y9	TEMP MTD, 3 BATT
Air Tanks:		(1) OUTSIDE LEFT
DEF Tank:		6.75 GAL
Engine:		6.6L GM DURAMAX

General Configuration Information

4X2 TRUCK CONFIGURATION
 REAR AIR SUSPENSION
 SIDE EXIT TAILPIPE AHEAD OF REAR WHEELS, RT SIDE (RPO NPK)
 OPTIONAL AIR DRYER FWD OUTSIDE RT (RPO KUT/JPY)

Minimum Wheelbase

219" WB (138" CA)
 75" AF

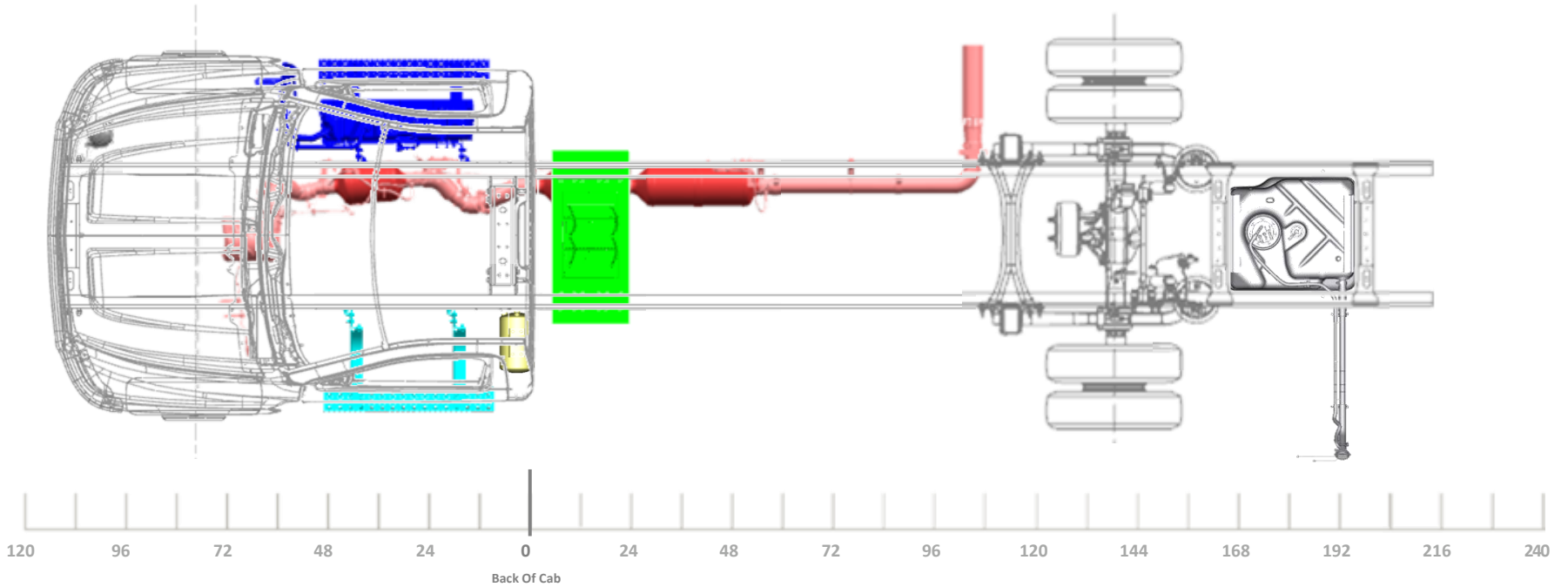

LAST REVISION: 9/25/2023

Model/Feature Information

Model:		C56403 K56403
Cab:		REGULAR CAB
Aftertreatment:		HORIZONTAL
Fuel Tank:	RPO NVK	25 GAL, CA MTD
Battery Box:	RPO 7Y7/7Y8	28" STEEL, 2 BATTERIES
Air Tanks:		(1) OUTSIDE LEFT
DEF Tank:		6.75 GAL
Engine:		6.6L GM DURAMAX

General Configuration Information

4X2 OR 4X4 TRUCK CONFIGURATION
 VARI-RATE REAR SUSPENSION

STRAIGHT TAILPIPE (RPO N12)

OPTIONAL AIR DRYER FWD OUTSIDE
 RT (RPO KUT/JPY)

Minimum Wheelbase

219" WB (138" CA)
 75" AF

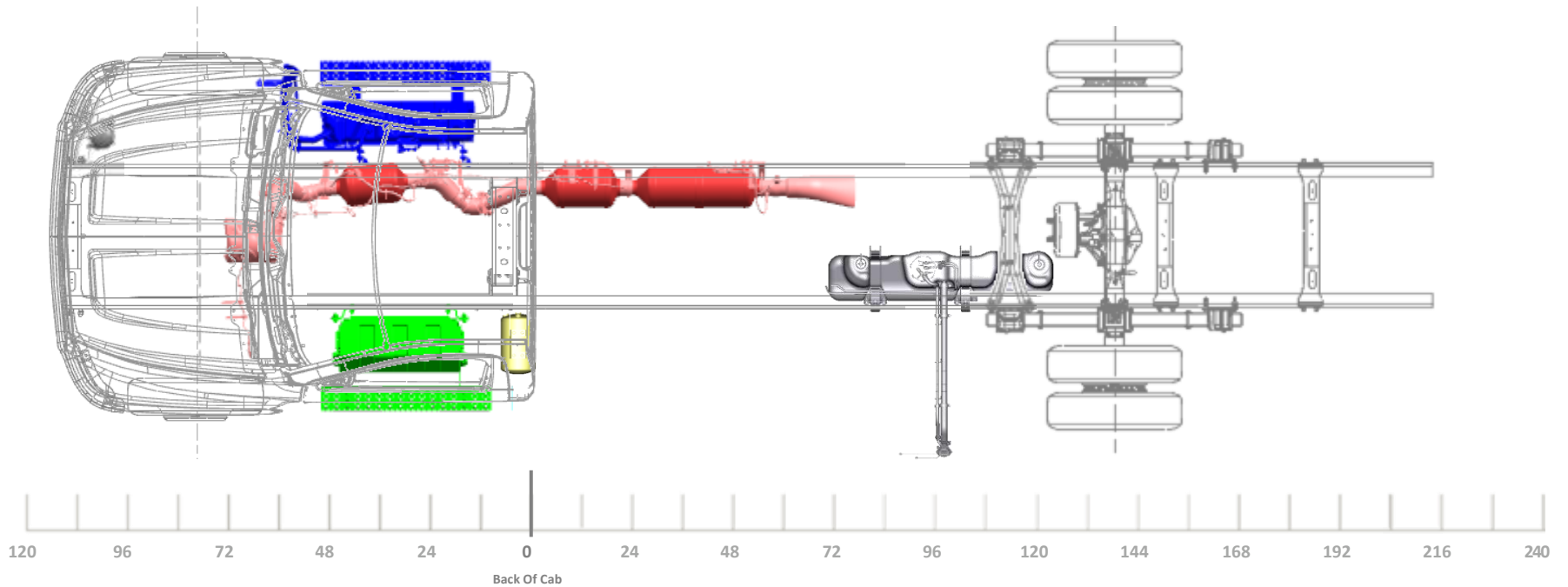

LAST REVISION: 9/25/2023

Model/Feature Information

Model:		C56403 K56403
Cab:		REGULAR CAB
Aftertreatment:		HORIZONTAL
Fuel Tank:	RPO NVK	25 GAL, CA MTD
Battery Box:	RPO 7Y7/7Y8	28" STEEL, 2 BATTERIES
Air Tanks:		(1) OUTSIDE LEFT
DEF Tank:		6.75 GAL
Engine:		6.6L GM DURAMAX

General Configuration Information

4X2 TRUCK CONFIGURATION
REAR AIR SUSPENSION
STRAIGHT TAILPIPE (RPO N12)
OPTIONAL AIR DRYER FWD OUTSIDE RT (RPO KUT/JPY)

Minimum Wheelbase

219" WB (138" CA)
75" AF

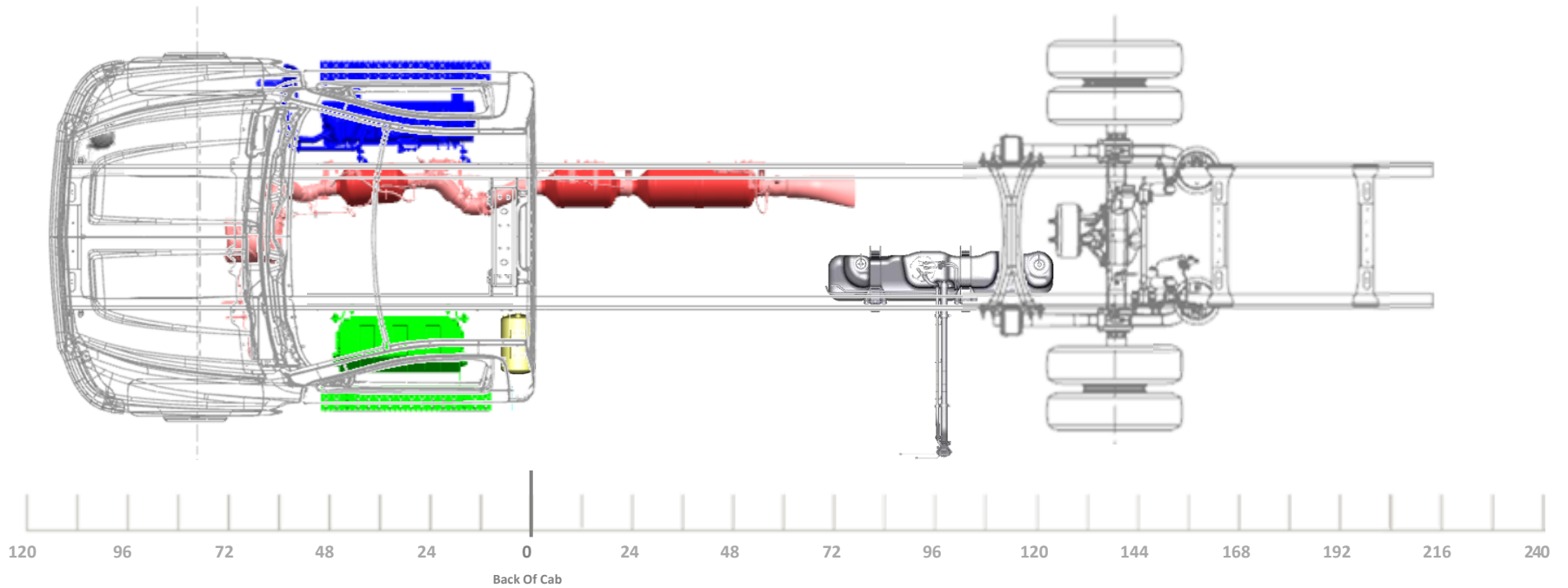

LAST REVISION: 9/25/2023

Model/Feature Information

Model:		C56403 K56403
Cab:		REGULAR CAB
Aftertreatment:		HORIZONTAL
Fuel Tank:	RPO NVK	25 GAL, CA MTD
Battery Box:	RPO 7Y9	TEMP MTD, 3 BATT
Air Tanks:		(1) OUTSIDE LEFT
DEF Tank:		6.75 GAL
Engine:		6.6L GM DURAMAX

General Configuration Information

4X2 OR 4X4 TRUCK CONFIGURATION
 VARI-RATE REAR SUSPENSION

STRAIGHT TAILPIPE (RPO N12)

OPTIONAL AIR DRYER FWD OUTSIDE
 RT (RPO KUT/JPY)

Minimum Wheelbase

219" WB (138" CA)
 75" AF

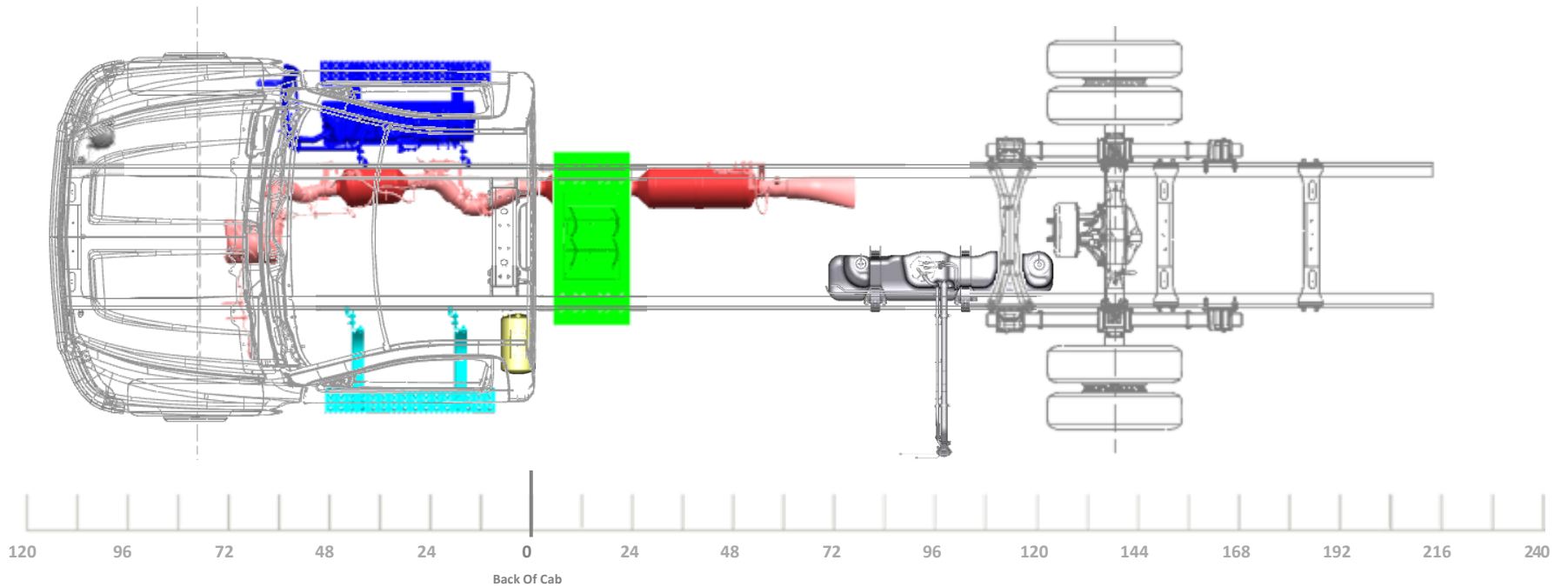

LAST REVISION: 9/25/2023

Model/Feature Information

Model:		C56403 K56403
Cab:		REGULAR CAB
Aftertreatment:		HORIZONTAL
Fuel Tank:	RPO NVK	25 GAL, CA MTD
Battery Box:	RPO 7Y9	TEMP MTD, 3 BATT
Air Tanks:		(1) OUTSIDE LEFT
DEF Tank:		6.75 GAL
Engine:		6.6L GM DURAMAX

General Configuration Information

4X2 TRUCK CONFIGURATION
REAR AIR SUSPENSION
STRAIGHT TAILPIPE (RPO N12)
OPTIONAL AIR DRYER FWD OUTSIDE RT (RPO KUT/JPY)

Minimum Wheelbase

219" WB (138" CA)
75" AF

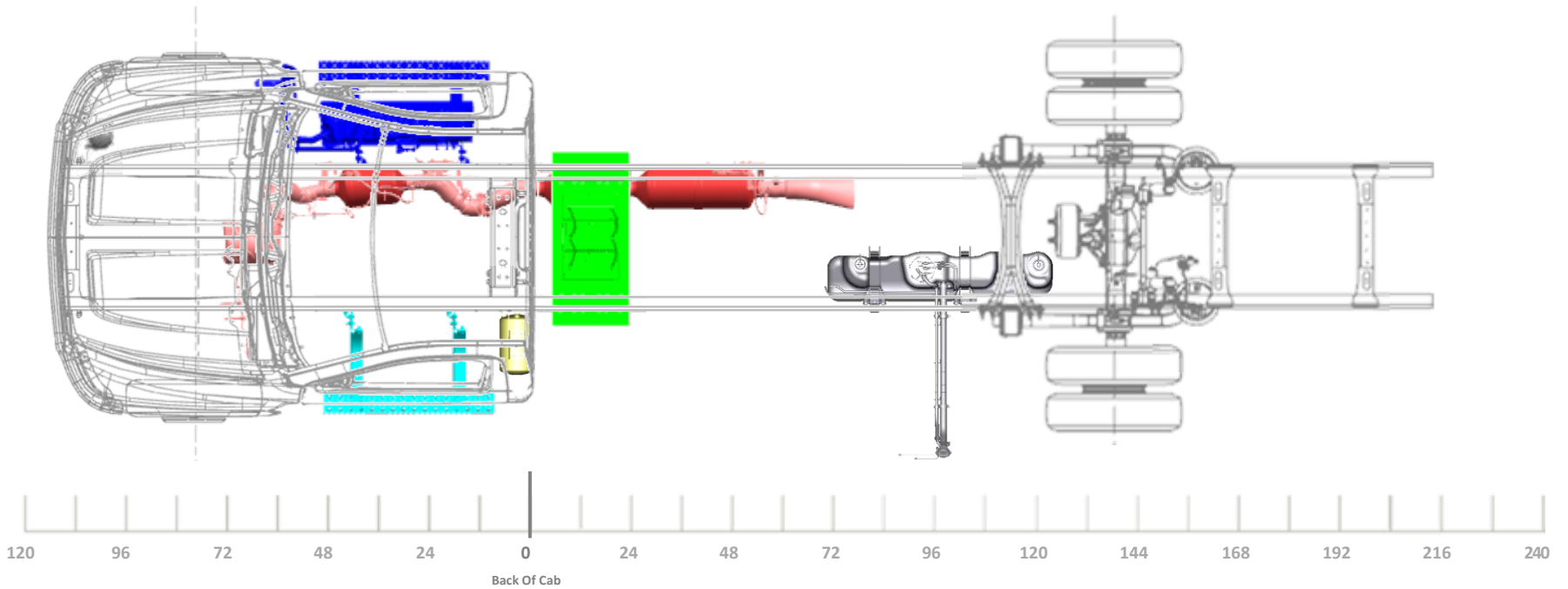

LAST REVISION: 9/25/2023

Model/Feature Information

Model:		C56403 K56403
Cab:		REGULAR CAB
Aftertreatment:		HORIZONTAL
Fuel Tank:	RPO NVK	25 GAL, CA MTD
Battery Box:	RPO 7Y7/7Y8	28" STEEL, 2 BATTERIES
Air Tanks:		(1) OUTSIDE LEFT
DEF Tank:		6.75 GAL
Engine:		6.6L GM DURAMAX

General Configuration Information

4X2 OR 4X4 TRUCK CONFIGURATION
VARI-RATE REAR SUSPENSION
SIDE EXIT TAILPIPE AHEAD OF REAR WHEELS, RT SIDE (RPO NPK)
OPTIONAL AIR DRYER FWD OUTSIDE RT (RPO KUT/JPY)

Minimum Wheelbase

219" WB (138" CA)
75" AF

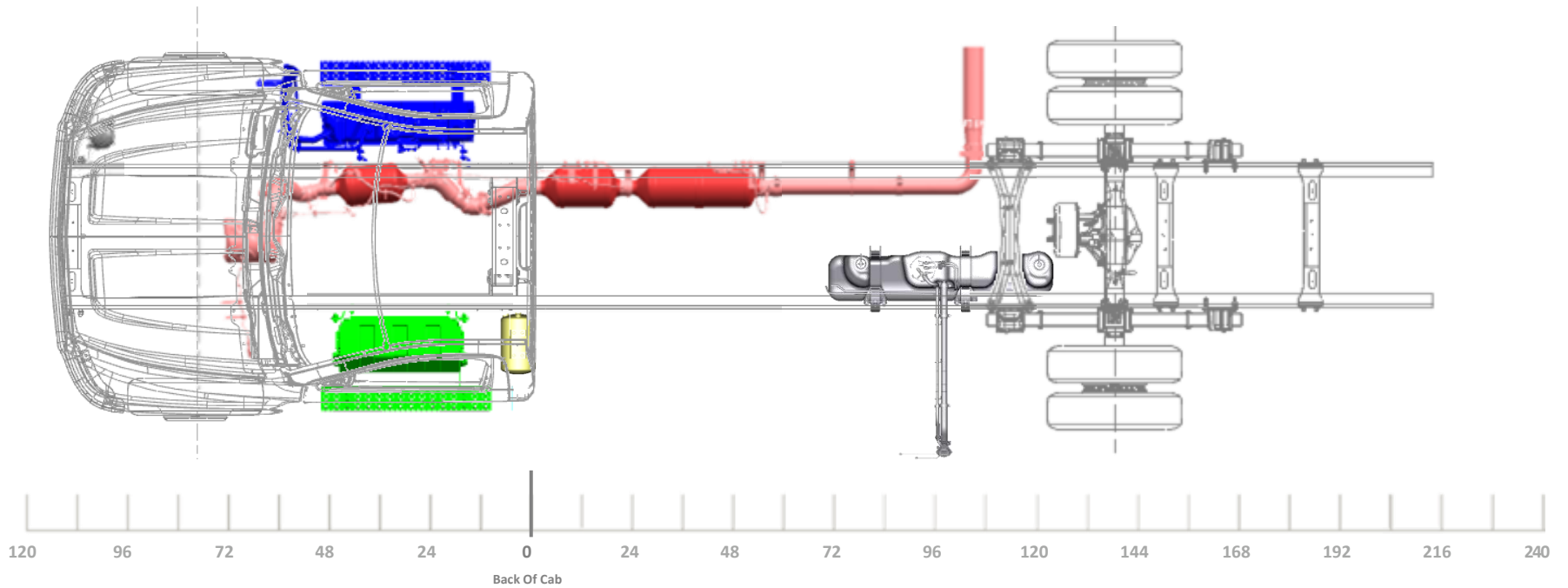

LAST REVISION: 9/25/2023

Model/Feature Information

Model:		C56403 K56403
Cab:		REGULAR CAB
Aftertreatment:		HORIZONTAL
Fuel Tank:	RPO NVK	25 GAL, CA MTD
Battery Box:	RPO 7Y7/7Y8	28" STEEL, 2 BATTERIES
Air Tanks:		(1) OUTSIDE LEFT
DEF Tank:		6.75 GAL
Engine:		6.6L GM DURAMAX

General Configuration Information

4X2 TRUCK CONFIGURATION
REAR AIR SUSPENSION
SIDE EXIT TAILPIPE AHEAD OF REAR WHEELS, RT SIDE (RPO NPK)
OPTIONAL AIR DRYER FWD OUTSIDE RT (RPO KUT/JPY)

Minimum Wheelbase

219" WB (138" CA)
75" AF

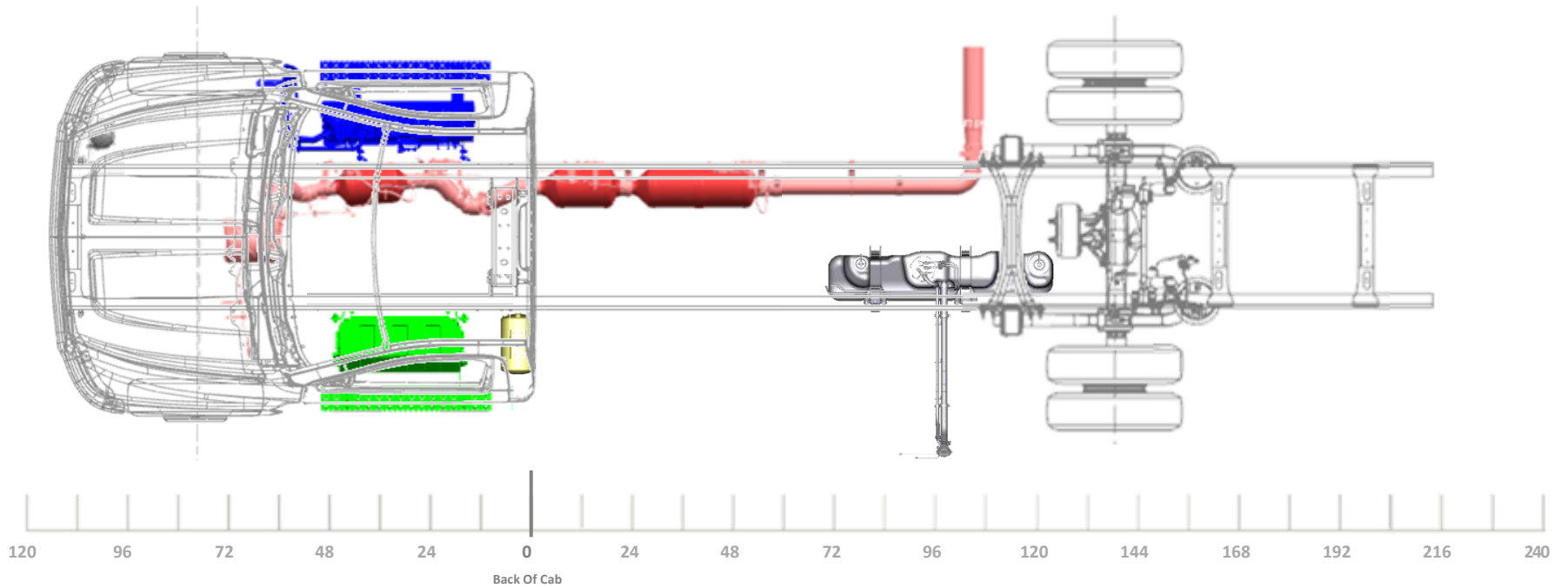

LAST REVISION: 9/25/2023

Model/Feature Information

Model:		C56403 K56403
Cab:		REGULAR CAB
Aftertreatment:		HORIZONTAL
Fuel Tank:	RPO NVK	25 GAL, CA MTD
Battery Box:	RPO 7Y9	TEMP MTD, 3 BATT
Air Tanks:		(1) OUTSIDE LEFT
DEF Tank:		6.75 GAL
Engine:		6.6L GM DURAMAX

General Configuration Information

4X2 OR 4X4 TRUCK CONFIGURATION
 VARI-RATE REAR SUSPENSION

SIDE EXIT TAILPIPE AHEAD OF REAR
 WHEELS, RT SIDE (RPO NPK)

OPTIONAL AIR DRYER FWD OUTSIDE
 RT (RPO KUT/JPY)

Minimum Wheelbase

219" WB (138" CA)
 75" AF

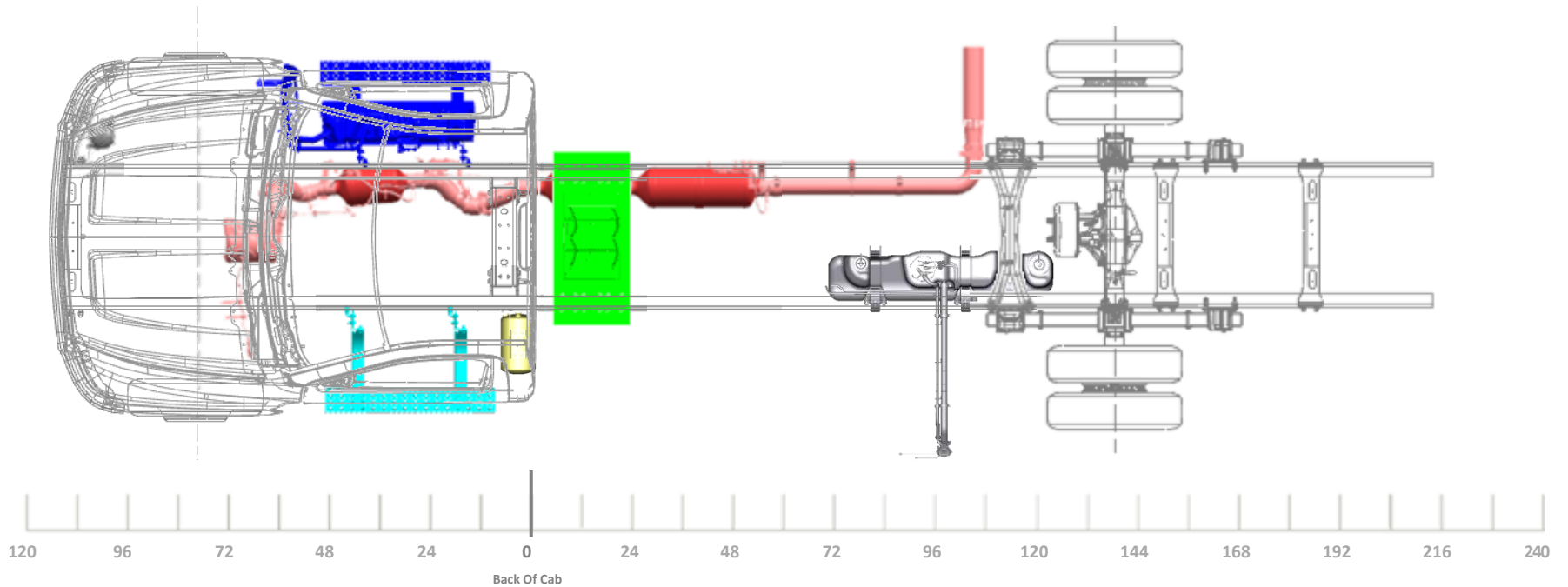

LAST REVISION: 9/25/2023

Model/Feature Information

Model:		C56403 K56403
Cab:		REGULAR CAB
Aftertreatment:		HORIZONTAL
Fuel Tank:	RPO NVK	25 GAL, CA MTD
Battery Box:	RPO 7Y9	TEMP MTD, 3 BATT
Air Tanks:		(1) OUTSIDE LEFT
DEF Tank:		6.75 GAL
Engine:		6.6L GM DURAMAX

General Configuration Information

4X2 TRUCK CONFIGURATION
 REAR AIR SUSPENSION
 SIDE EXIT TAILPIPE AHEAD OF REAR WHEELS, RT SIDE (RPO NPK)
 OPTIONAL AIR DRYER FWD OUTSIDE RT (RPO KUT/JPY)

Minimum Wheelbase

219" WB (138" CA)
 75" AF

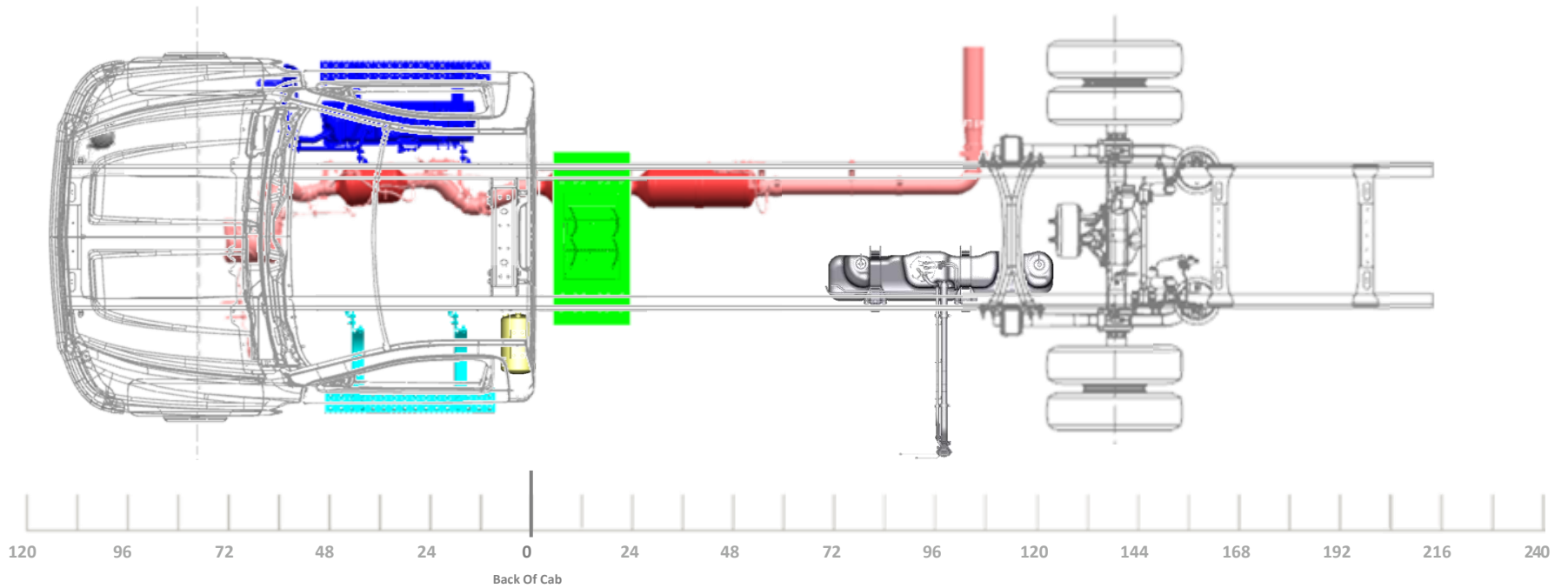

LAST REVISION: 9/25/2023

Model/Feature Information

Model:		C56403 K56403
Cab:		REGULAR CAB
Aftertreatment:		HORIZONTAL
Fuel Tank:	RPO NSQ	DUAL 25G CA, 40G AF
Battery Box:	RPO 7Y7/7Y8	28" STEEL, 2 BATTERIES
Air Tanks:		(1) OUTSIDE LEFT
DEF Tank:		6.75 GAL
Engine:		6.6L GM DURAMAX

General Configuration Information

4X2 OR 4X4 TRUCK CONFIGURATION
 VARI-RATE REAR SUSPENSION

STRAIGHT TAILPIPE (RPO N12)

OPTIONAL AIR DRYER FWD OUTSIDE
 RT (RPO KUT/JPY)

Minimum Wheelbase

219" WB (138" CA)
 75" AF

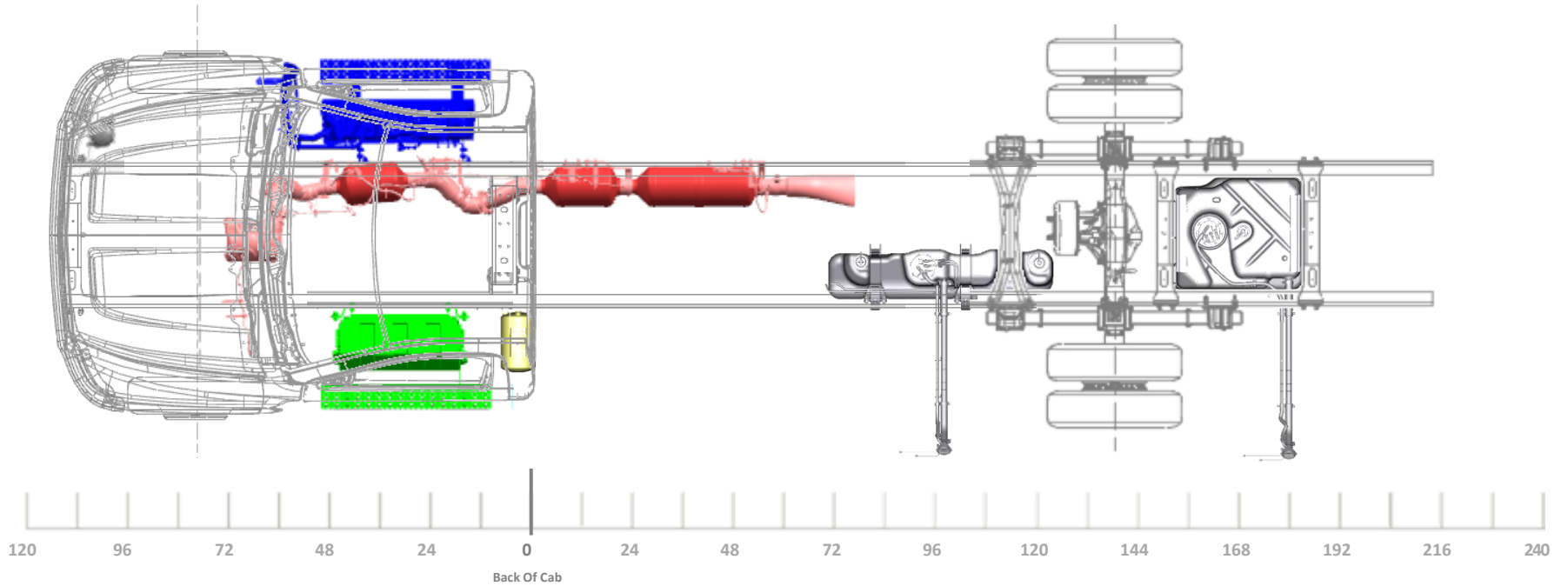

LAST REVISION: 9/25/2023

Model/Feature Information

Model:		C56403 K56403
Cab:		REGULAR CAB
Aftertreatment:		HORIZONTAL
Fuel Tank:	RPO NSQ	DUAL 25G CA, 40G AF
Battery Box:	RPO 7Y7/7Y8	28" STEEL, 2 BATTERIES
Air Tanks:		(1) OUTSIDE LEFT
DEF Tank:		6.75 GAL
Engine:		6.6L GM DURAMAX

General Configuration Information

4X2 TRUCK CONFIGURATION
REAR AIR SUSPENSION
STRAIGHT TAILPIPE (RPO N12)
OPTIONAL AIR DRYER FWD OUTSIDE RT (RPO KUT/JPY)

Minimum Wheelbase

219" WB (138" CA)
75" AF

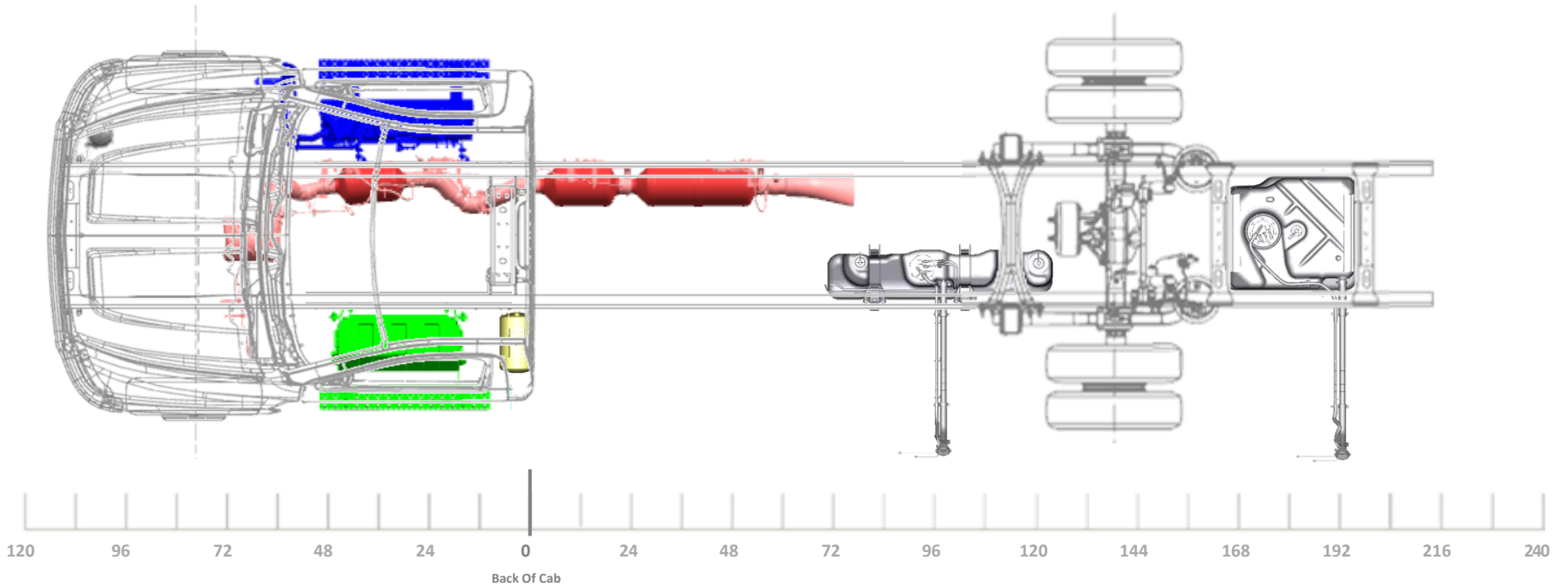

LAST REVISION: 9/25/2023

Model/Feature Information

Model:		C56403 K56403
Cab:		REGULAR CAB
Aftertreatment:		HORIZONTAL
Fuel Tank:	RPO NSQ	DUAL 25G CA, 40G AF
Battery Box:	RPO 7Y9	TEMP MTD, 3 BATT
Air Tanks:		(1) OUTSIDE LEFT
DEF Tank:		6.75 GAL
Engine:		6.6L GM DURAMAX

General Configuration Information

4X2 OR 4X4 TRUCK CONFIGURATION
 VARI-RATE REAR SUSPENSION

STRAIGHT TAILPIPE (RPO N12)

OPTIONAL AIR DRYER FWD OUTSIDE
 RT (RPO KUT/JPY)

Minimum Wheelbase

219" WB (138" CA)
 75" AF

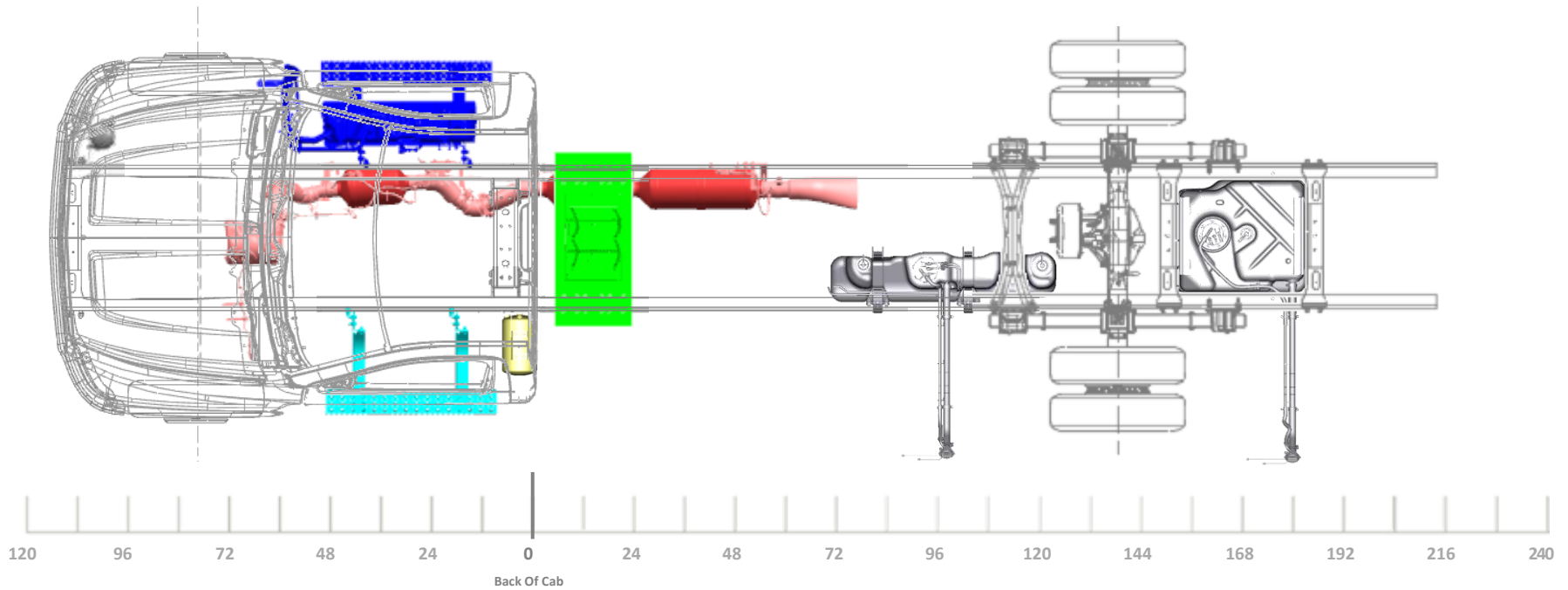

LAST REVISION: 9/25/2023

Model/Feature Information

Model:		C56403 K56403
Cab:		REGULAR CAB
Aftertreatment:		HORIZONTAL
Fuel Tank:	RPO NSQ	DUAL 25G CA, 40G AF
Battery Box:	RPO 7Y9	TEMP MTD, 3 BATT
Air Tanks:		(1) OUTSIDE LEFT
DEF Tank:		6.75 GAL
Engine:		6.6L GM DURAMAX

General Configuration Information

4X2 TRUCK CONFIGURATION
REAR AIR SUSPENSION
STRAIGHT TAILPIPE (RPO N12)
OPTIONAL AIR DRYER FWD OUTSIDE RT (RPO KUT/JPY)

Minimum Wheelbase

219" WB (138" CA)
75" AF

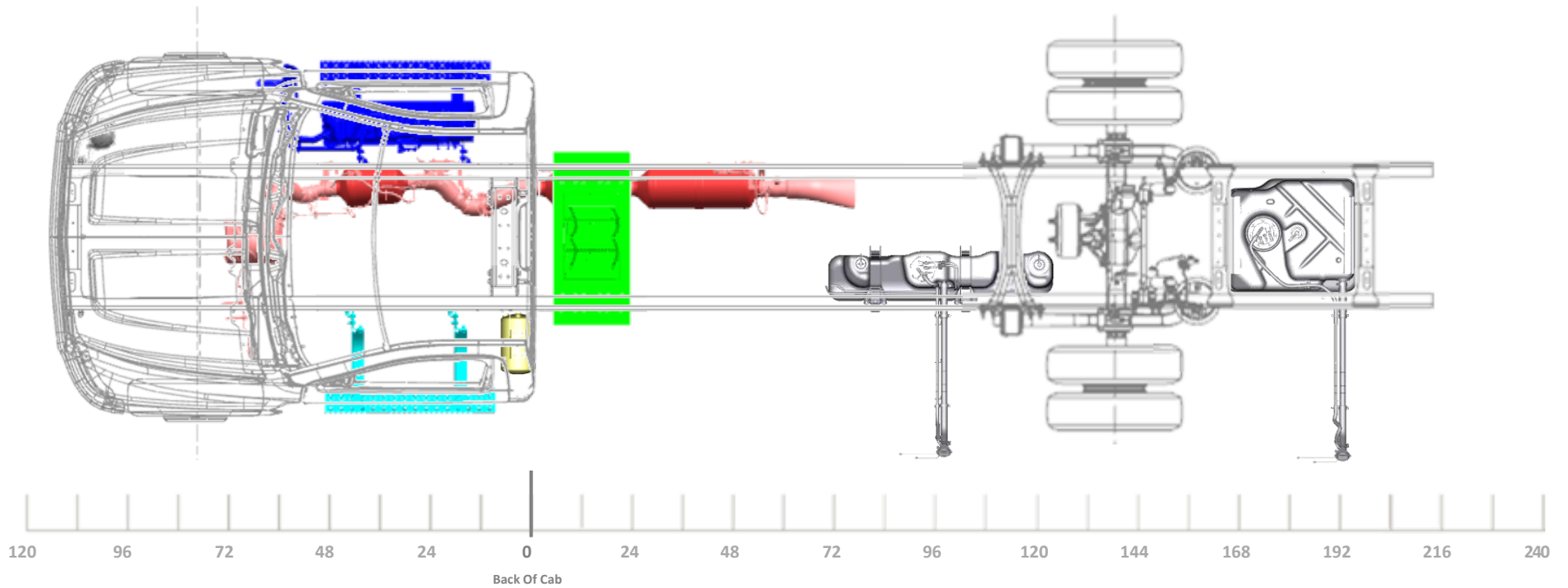

LAST REVISION: 9/25/2023

Model/Feature Information

Model:		C56403 K56403
Cab:		REGULAR CAB
Aftertreatment:		HORIZONTAL
Fuel Tank:	RPO NSQ	DUAL 25G CA, 40G AF
Battery Box:	RPO 7Y7/7Y8	28" STEEL, 2 BATTERIES
Air Tanks:		(1) OUTSIDE LEFT
DEF Tank:		6.75 GAL
Engine:		6.6L GM DURAMAX

General Configuration Information

4X2 OR 4X4 TRUCK CONFIGURATION
 VARI-RATE REAR SUSPENSION
 SIDE EXIT TAILPIPE AHEAD OF REAR WHEELS, RT SIDE (RPO NPK)
 OPTIONAL AIR DRYER FWD OUTSIDE RT (RPO KUT/JPY)

Minimum Wheelbase

219" WB (138" CA)
 75" AF

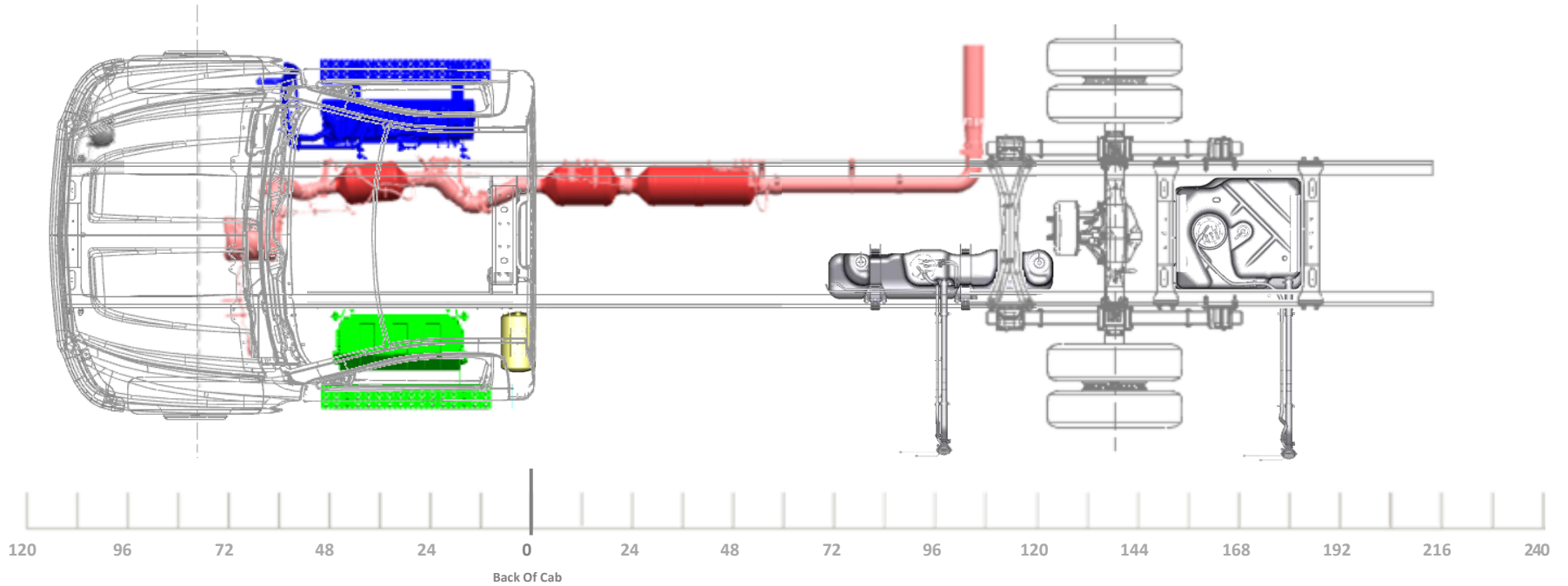

LAST REVISION: 9/25/2023

Model/Feature Information

Model:		C56403 K56403
Cab:		REGULAR CAB
Aftertreatment:		HORIZONTAL
Fuel Tank:	RPO NSQ	DUAL 25G CA, 40G AF
Battery Box:	RPO 7Y7/7Y8	28" STEEL, 2 BATTERIES
Air Tanks:		(1) OUTSIDE LEFT
DEF Tank:		6.75 GAL
Engine:		6.6L GM DURAMAX

General Configuration Information

4X2 TRUCK CONFIGURATION
 REAR AIR SUSPENSION
 SIDE EXIT TAILPIPE AHEAD OF REAR WHEELS, RT SIDE (RPO NPK)
 OPTIONAL AIR DRYER FWD OUTSIDE RT (RPO KUT/JPY)

Minimum Wheelbase

219" WB (138" CA)
 75" AF

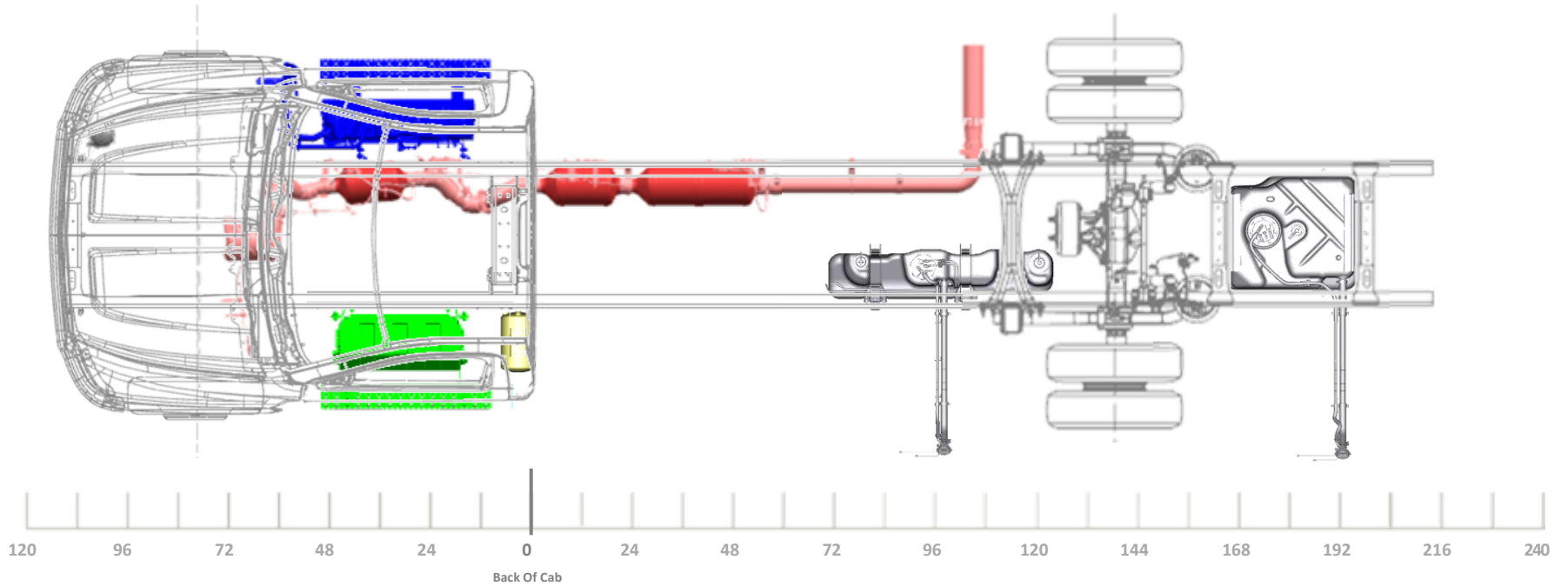

LAST REVISION: 9/25/2023

Model/Feature Information

Model:		C56403 K56403
Cab:		REGULAR CAB
Aftertreatment:		HORIZONTAL
Fuel Tank:	RPO NSQ	DUAL 25G CA, 40G AF
Battery Box:	RPO 7Y9	TEMP MTD, 3 BATT
Air Tanks:		(1) OUTSIDE LEFT
DEF Tank:		6.75 GAL
Engine:		6.6L GM DURAMAX

General Configuration Information

4X2 OR 4X4 TRUCK CONFIGURATION
 VARI-RATE REAR SUSPENSION

SIDE EXIT TAILPIPE AHEAD OF REAR
 WHEELS, RT SIDE (RPO NPK)

OPTIONAL AIR DRYER FWD OUTSIDE
 RT (RPO KUT/JPY)

Minimum Wheelbase

219" WB (138" CA)
 75" AF

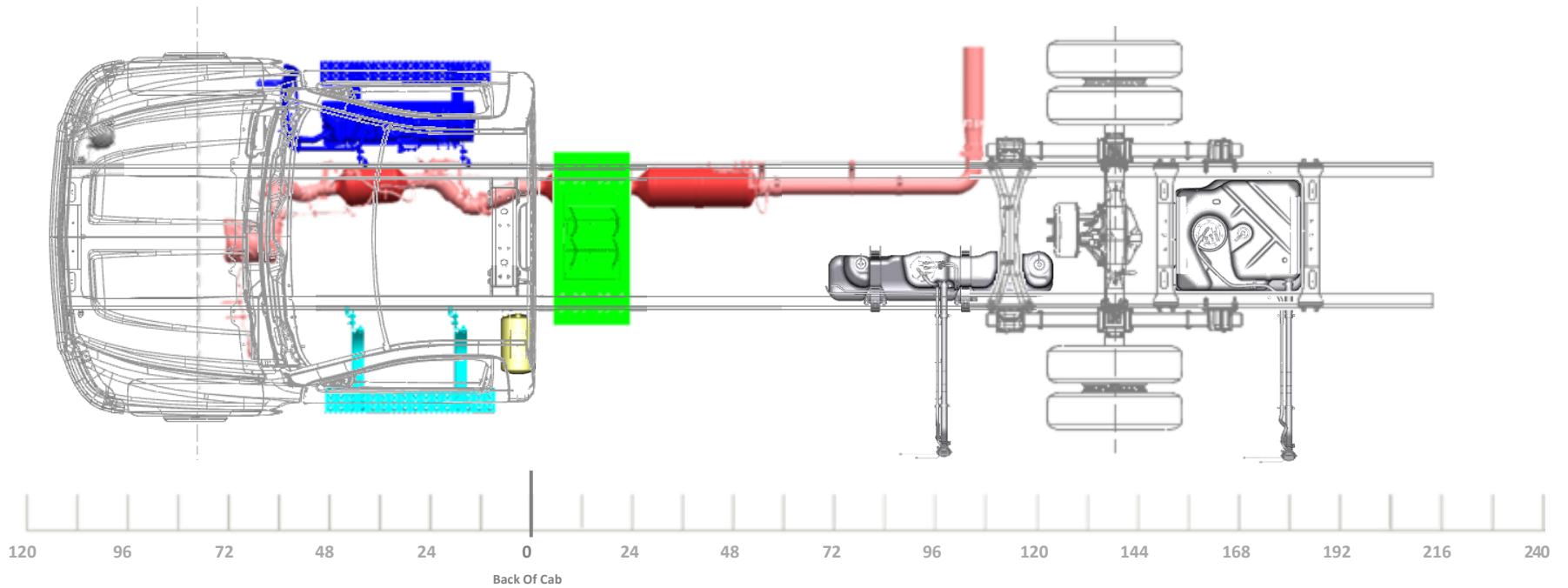

LAST REVISION: 9/25/2023

Model/Feature Information

Model:		C56403 K56403
Cab:		REGULAR CAB
Aftertreatment:		HORIZONTAL
Fuel Tank:	RPO NSQ	DUAL 25G CA, 40G AF
Battery Box:	RPO 7Y9	TEMP MTD, 3 BATT
Air Tanks:		(1) OUTSIDE LEFT
DEF Tank:		6.75 GAL
Engine:		6.6L GM DURAMAX

General Configuration Information

4X2 TRUCK CONFIGURATION
 REAR AIR SUSPENSION
 SIDE EXIT TAILPIPE AHEAD OF REAR WHEELS, RT SIDE (RPO NPK)
 OPTIONAL AIR DRYER FWD OUTSIDE RT (RPO KUT/JPY)

Minimum Wheelbase

219" WB (138" CA)
 75" AF

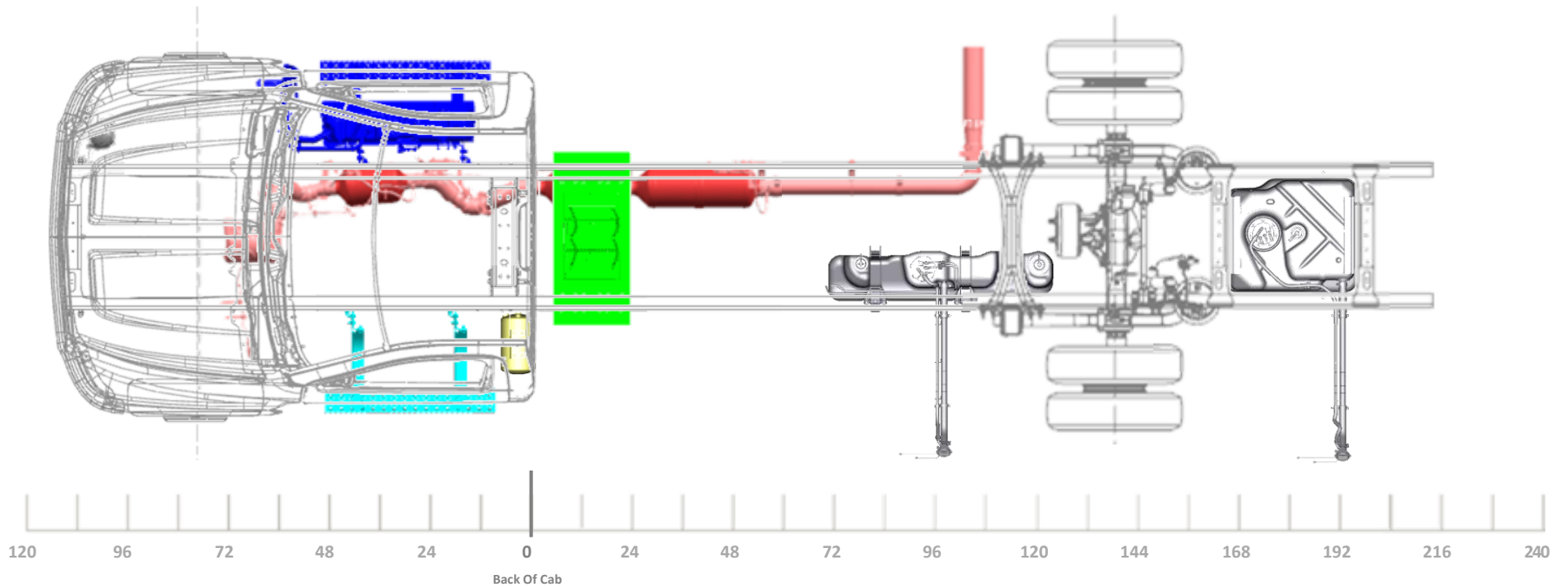

LAST REVISION: 9/25/2023

REGULAR
CAB 231"
WB

Model/Feature Information

Model:		C56403 K56403
Cab:		REGULAR CAB
Aftertreatment:		HORIZONTAL
Fuel Tank:	RPO N2L	40 GAL, AF MTD
Battery Box:	RPO 7Y7/7Y8	28" STEEL, 2 BATTERIES
Air Tanks:		(1) OUTSIDE LEFT
DEF Tank:		6.75 GAL
Engine:		6.6L GM DURAMAX

General Configuration Information

4X2 OR 4X4 TRUCK CONFIGURATION
 VARI-RATE REAR SUSPENSION

STRAIGHT TAILPIPE (RPO N12)

OPTIONAL AIR DRYER FWD OUTSIDE
 RT (RPO KUT/JPY)

Minimum Wheelbase

231" WB (150" CA)
 91" AF

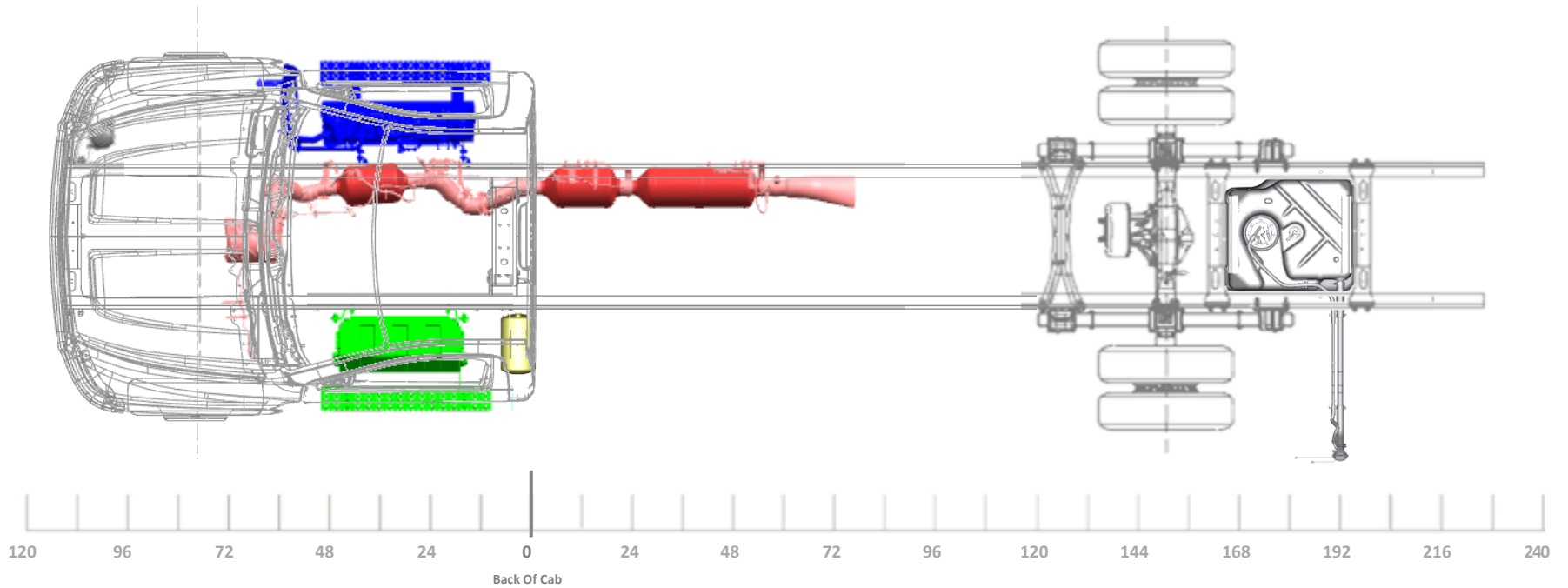

LAST REVISION: 9/25/2023

Model/Feature Information

Model:		C56403 K56403
Cab:		REGULAR CAB
Aftertreatment:		HORIZONTAL
Fuel Tank:	RPO N2L	40 GAL, AF MTD
Battery Box:	RPO 7Y7/7Y8	28" STEEL, 2 BATTERIES
Air Tanks:		(1) OUTSIDE LEFT
DEF Tank:		6.75 GAL
Engine:		6.6L GM DURAMAX

General Configuration Information

4X2 TRUCK CONFIGURATION
REAR AIR SUSPENSION
STRAIGHT TAILPIPE (RPO N12)
OPTIONAL AIR DRYER FWD OUTSIDE RT (RPO KUT/JPY)

Minimum Wheelbase

231" WB (150" CA)
91" AF

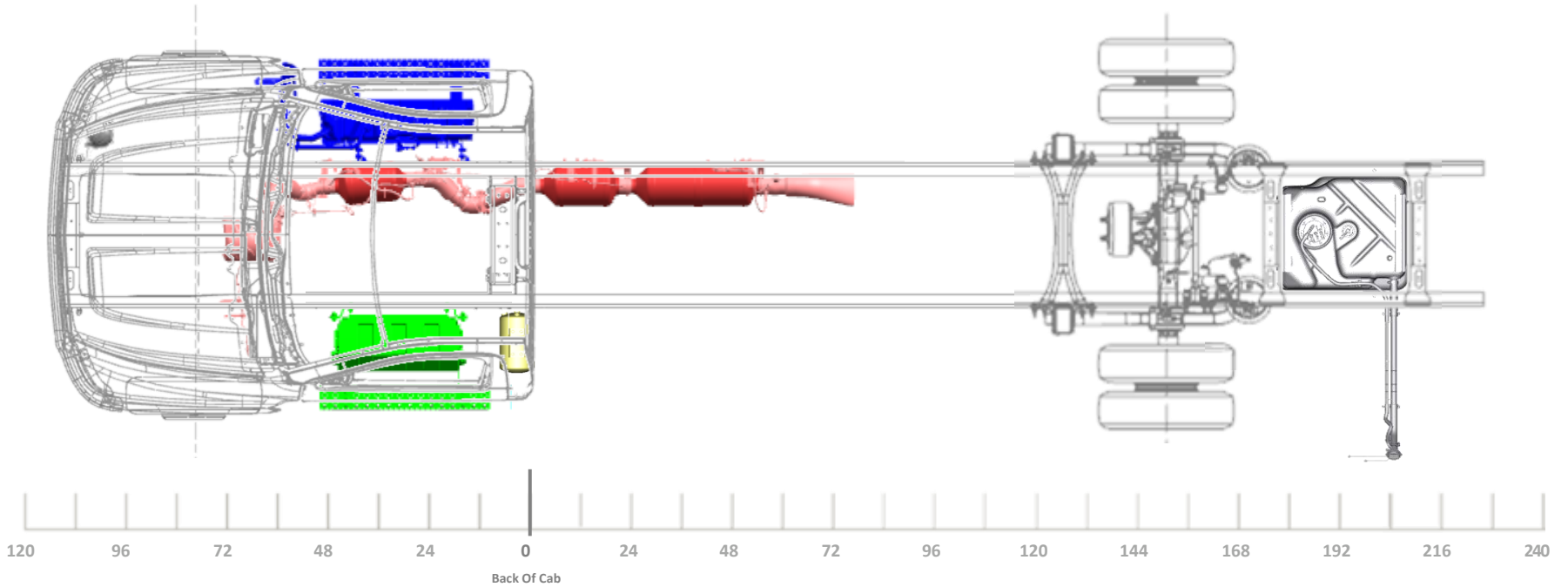

LAST REVISION: 9/25/2023

Model/Feature Information

Model:		C56403 K56403
Cab:		REGULAR CAB
Aftertreatment:		HORIZONTAL
Fuel Tank:	RPO N2L	40 GAL, AF MTD
Battery Box:	RPO 7Y9	TEMP MTD, 3 BATT
Air Tanks:		(1) OUTSIDE LEFT
DEF Tank:		6.75 GAL
Engine:		6.6L GM DURAMAX

General Configuration Information

4X2 OR 4X4 TRUCK CONFIGURATION
 VARI-RATE REAR SUSPENSION

STRAIGHT TAILPIPE (RPO N12)

OPTIONAL AIR DRYER FWD OUTSIDE
 RT (RPO KUT/JPY)

Minimum Wheelbase

231" WB (150" CA)
 91" AF

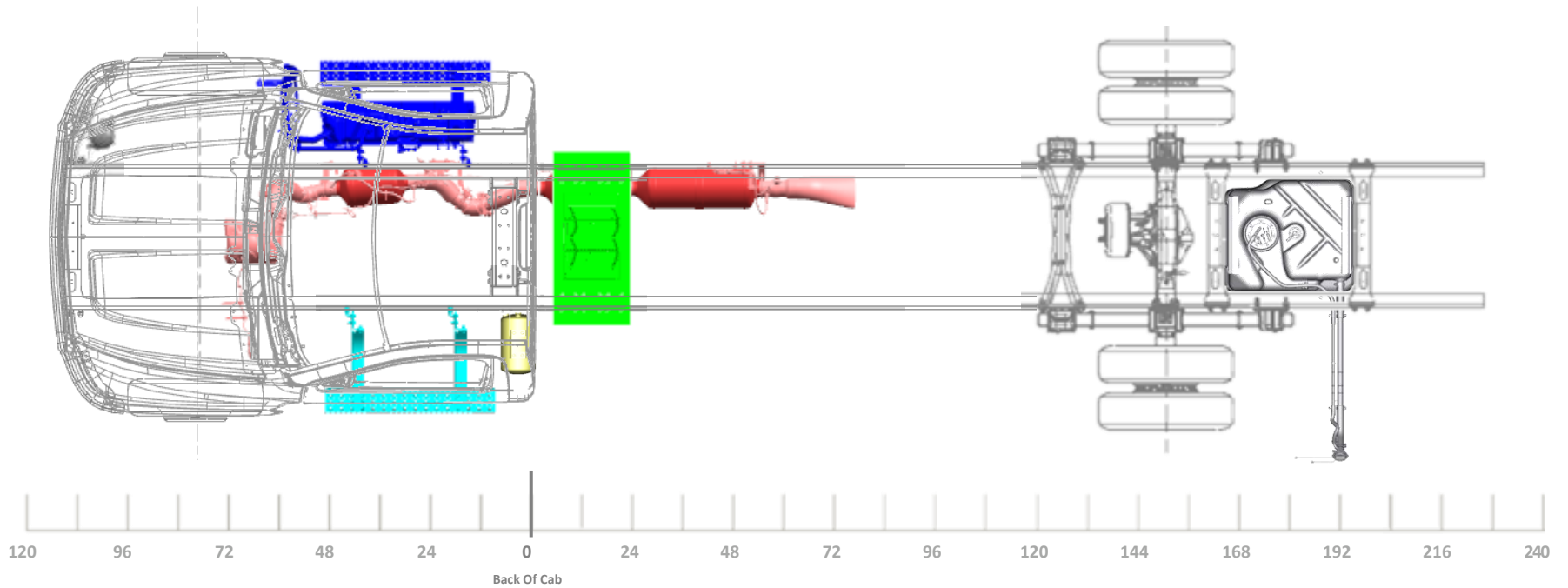

LAST REVISION: 9/25/2023

Model/Feature Information

Model:		C56403 K56403
Cab:		REGULAR CAB
Aftertreatment:		HORIZONTAL
Fuel Tank:	RPO N2L	40 GAL, AF MTD
Battery Box:	RPO 7Y9	TEMP MTD, 3 BATT
Air Tanks:		(1) OUTSIDE LEFT
DEF Tank:		6.75 GAL
Engine:		6.6L GM DURAMAX

General Configuration Information

4X2 TRUCK CONFIGURATION
REAR AIR SUSPENSION
STRAIGHT TAILPIPE (RPO N12)
OPTIONAL AIR DRYER FWD OUTSIDE RT (RPO KUT/JPY)

Minimum Wheelbase

231" WB (150" CA)
91" AF

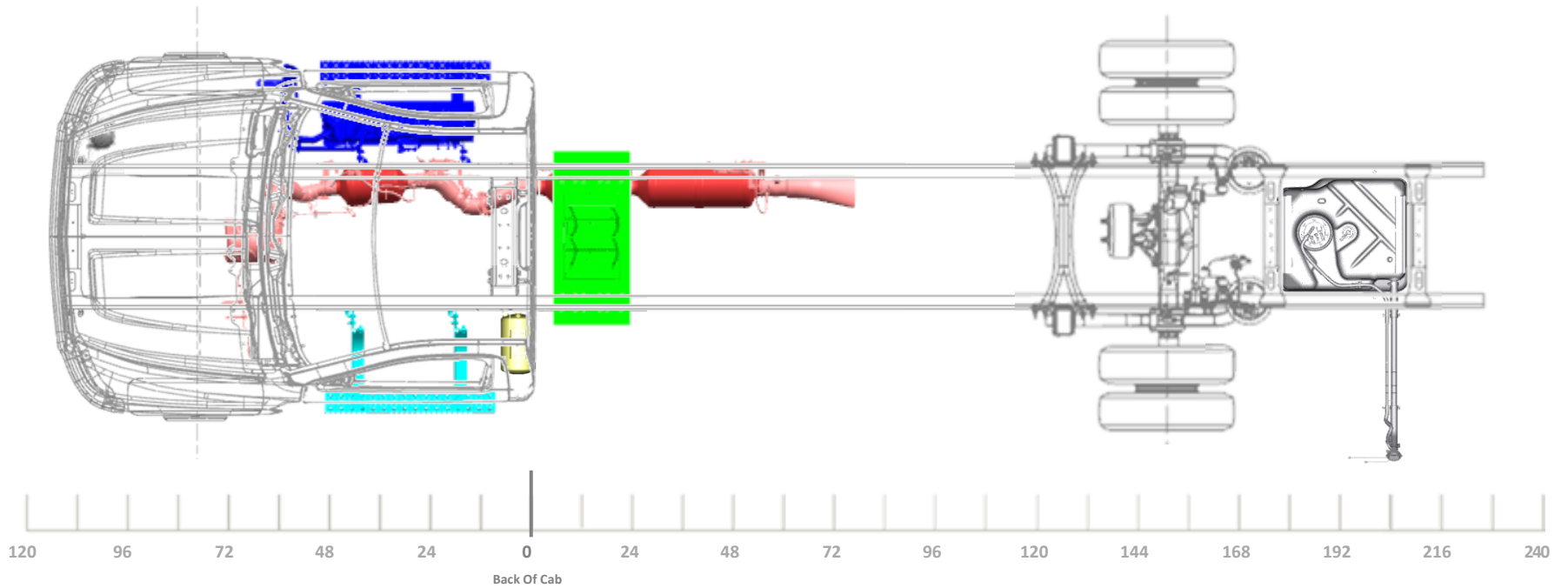

LAST REVISION: 9/25/2023

Model/Feature Information

Model:		C56403 K56403
Cab:		REGULAR CAB
Aftertreatment:		HORIZONTAL
Fuel Tank:	RPO N2L	40 GAL, AF MTD
Battery Box:	RPO 7Y7/7Y8	28" STEEL, 2 BATTERIES
Air Tanks:		(1) OUTSIDE LEFT
DEF Tank:		6.75 GAL
Engine:		6.6L GM DURAMAX

General Configuration Information

4X2 OR 4X4 TRUCK CONFIGURATION
 VARI-RATE REAR SUSPENSION
 SIDE EXIT TAILPIPE AHEAD OF REAR WHEELS, LT SIDE (RPO NPJ)
 OPTIONAL AIR DRYER FWD OUTSIDE RT (RPO KUT/JPY)

Minimum Wheelbase

231" WB (150" CA)
 91" AF

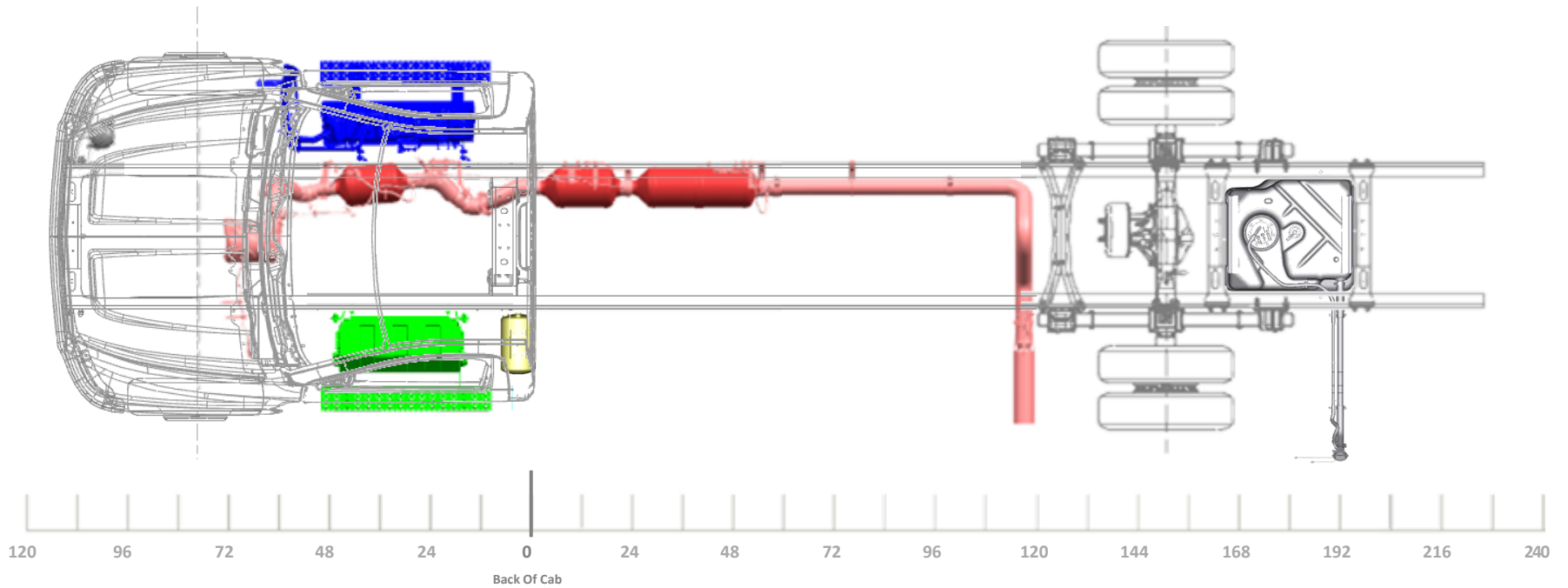

LAST REVISION: 9/25/2023

Model/Feature Information

Model:		C56403 K56403
Cab:		REGULAR CAB
Aftertreatment:		HORIZONTAL
Fuel Tank:	RPO N2L	40 GAL, AF MTD
Battery Box:	RPO 7Y7/7Y8	28" STEEL, 2 BATTERIES
Air Tanks:		(1) OUTSIDE LEFT
DEF Tank:		6.75 GAL
Engine:		6.6L GM DURAMAX

General Configuration Information

4X2 TRUCK CONFIGURATION
REAR AIR SUSPENSION
SIDE EXIT TAILPIPE AHEAD OF REAR WHEELS, LT SIDE (RPO NPJ)
OPTIONAL AIR DRYER FWD OUTSIDE RT (RPO KUT/JPY)

Minimum Wheelbase

231" WB (150" CA)
91" AF

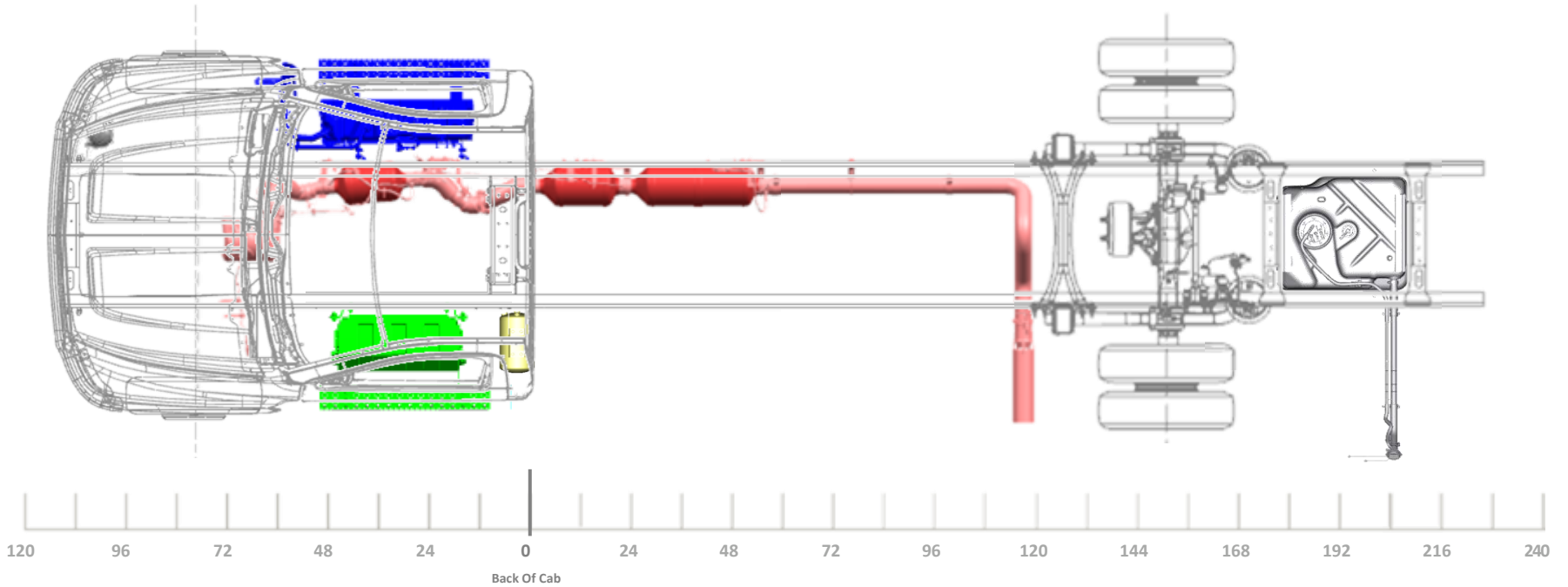

LAST REVISION: 9/25/2023

Model/Feature Information

Model:		C56403 K56403
Cab:		REGULAR CAB
Aftertreatment:		HORIZONTAL
Fuel Tank:	RPO N2L	40 GAL, AF MTD
Battery Box:	RPO 7Y9	TEMP MTD, 3 BATT
Air Tanks:		(1) OUTSIDE LEFT
DEF Tank:		6.75 GAL
Engine:		6.6L GM DURAMAX

General Configuration Information

4X2 OR 4X4 TRUCK CONFIGURATION
 VARI-RATE REAR SUSPENSION

SIDE EXIT TAILPIPE AHEAD OF REAR
 WHEELS, LT SIDE (RPO NPJ)

OPTIONAL AIR DRYER FWD OUTSIDE
 RT (RPO KUT/JPY)

Minimum Wheelbase

231" WB (150" CA)
 91" AF

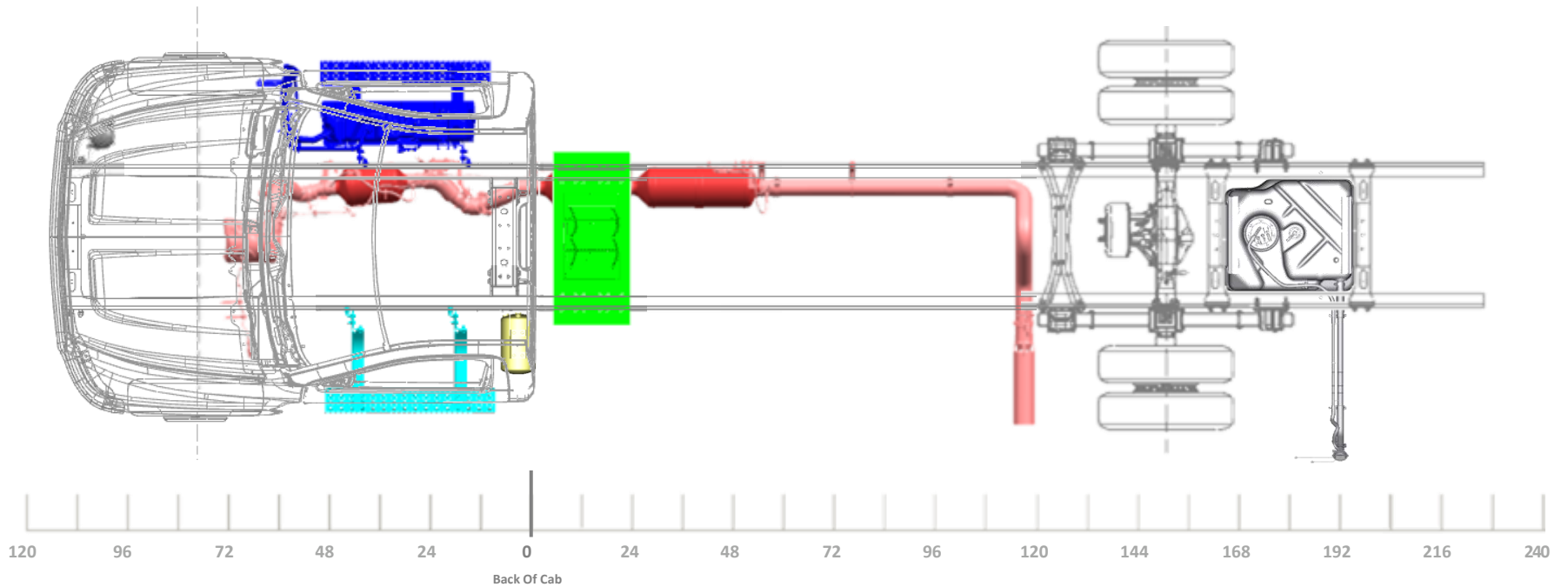

LAST REVISION: 9/25/2023

Model/Feature Information

Model:		C56403 K56403
Cab:		REGULAR CAB
Aftertreatment:		HORIZONTAL
Fuel Tank:	RPO N2L	40 GAL, AF MTD
Battery Box:	RPO 7Y9	TEMP MTD, 3 BATT
Air Tanks:		(1) OUTSIDE LEFT
DEF Tank:		6.75 GAL
Engine:		6.6L GM DURAMAX

General Configuration Information

4X2 TRUCK CONFIGURATION
REAR AIR SUSPENSION
SIDE EXIT TAILPIPE AHEAD OF REAR WHEELS, LT SIDE (RPO NPJ)
OPTIONAL AIR DRYER FWD OUTSIDE RT (RPO KUT/JPY)

Minimum Wheelbase

231" WB (150" CA)
91" AF

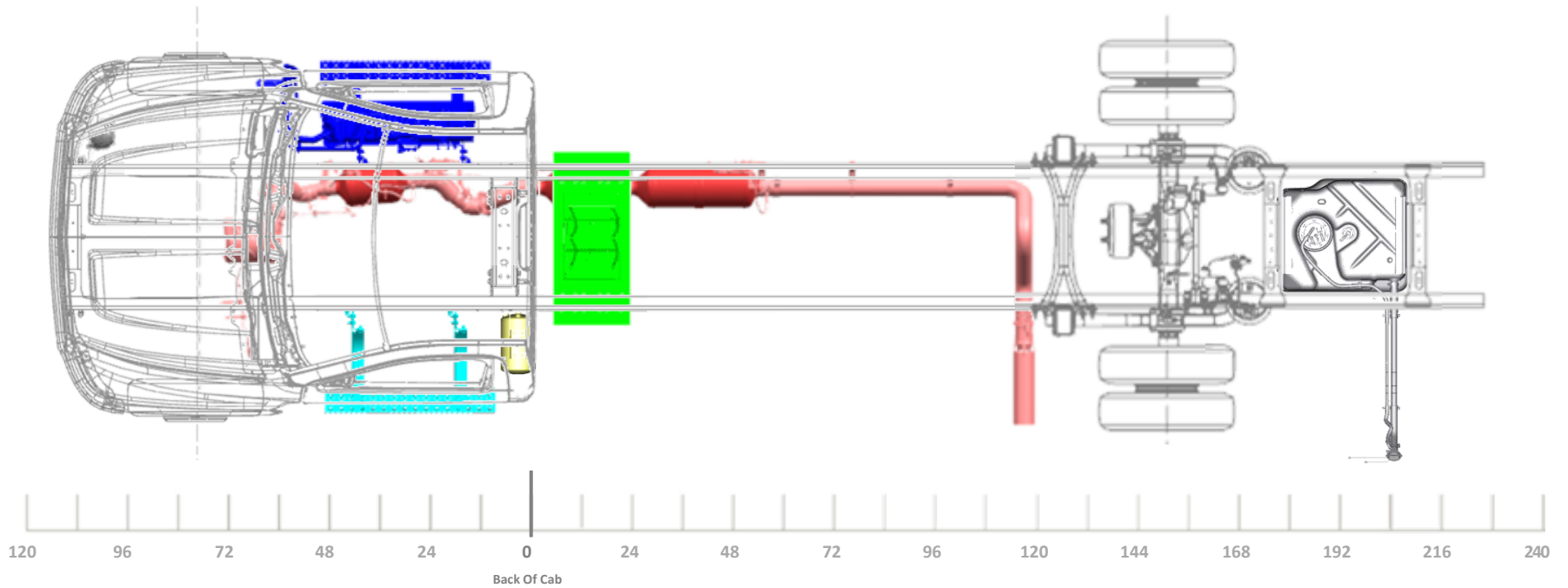

LAST REVISION: 9/25/2023

Model/Feature Information

Model:		C56403 K56403
Cab:		REGULAR CAB
Aftertreatment:		HORIZONTAL
Fuel Tank:	RPO N2L	40 GAL, AF MTD
Battery Box:	RPO 7Y7/7Y8	28" STEEL, 2 BATTERIES
Air Tanks:		(1) OUTSIDE LEFT
DEF Tank:		6.75 GAL
Engine:		6.6L GM DURAMAX

General Configuration Information

4X2 OR 4X4 TRUCK CONFIGURATION
VARI-RATE REAR SUSPENSION
SIDE EXIT TAILPIPE AHEAD OF REAR WHEELS, RT SIDE (RPO NPK)
OPTIONAL AIR DRYER FWD OUTSIDE RT (RPO KUT/JPY)

Minimum Wheelbase

231" WB (150" CA)
91" AF

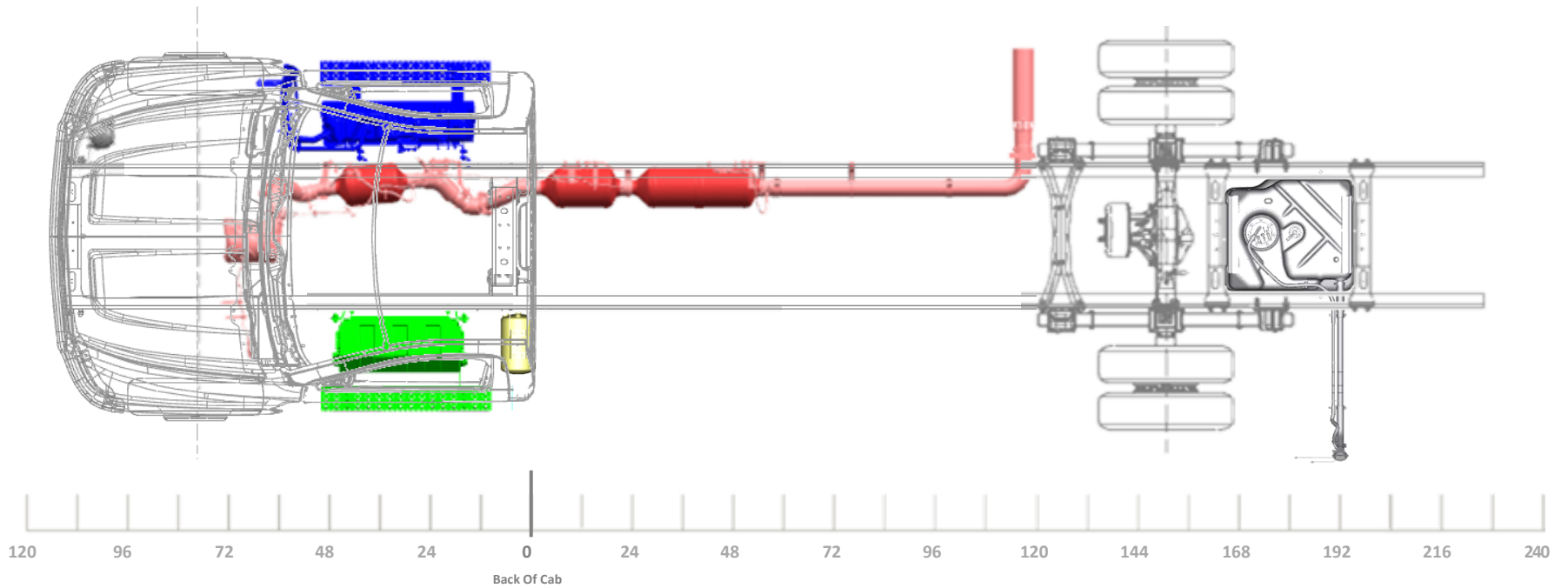

LAST REVISION: 9/25/2023

Model/Feature Information

Model:		C56403 K56403
Cab:		REGULAR CAB
Aftertreatment:		HORIZONTAL
Fuel Tank:	RPO N2L	40 GAL, AF MTD
Battery Box:	RPO 7Y7/7Y8	28" STEEL, 2 BATTERIES
Air Tanks:		(1) OUTSIDE LEFT
DEF Tank:		6.75 GAL
Engine:		6.6L GM DURAMAX

General Configuration Information

4X2 TRUCK CONFIGURATION
REAR AIR SUSPENSION
SIDE EXIT TAILPIPE AHEAD OF REAR WHEELS, RT SIDE (RPO NPK)
OPTIONAL AIR DRYER FWD OUTSIDE RT (RPO KUT/JPY)

Minimum Wheelbase

231" WB (150" CA)
91" AF

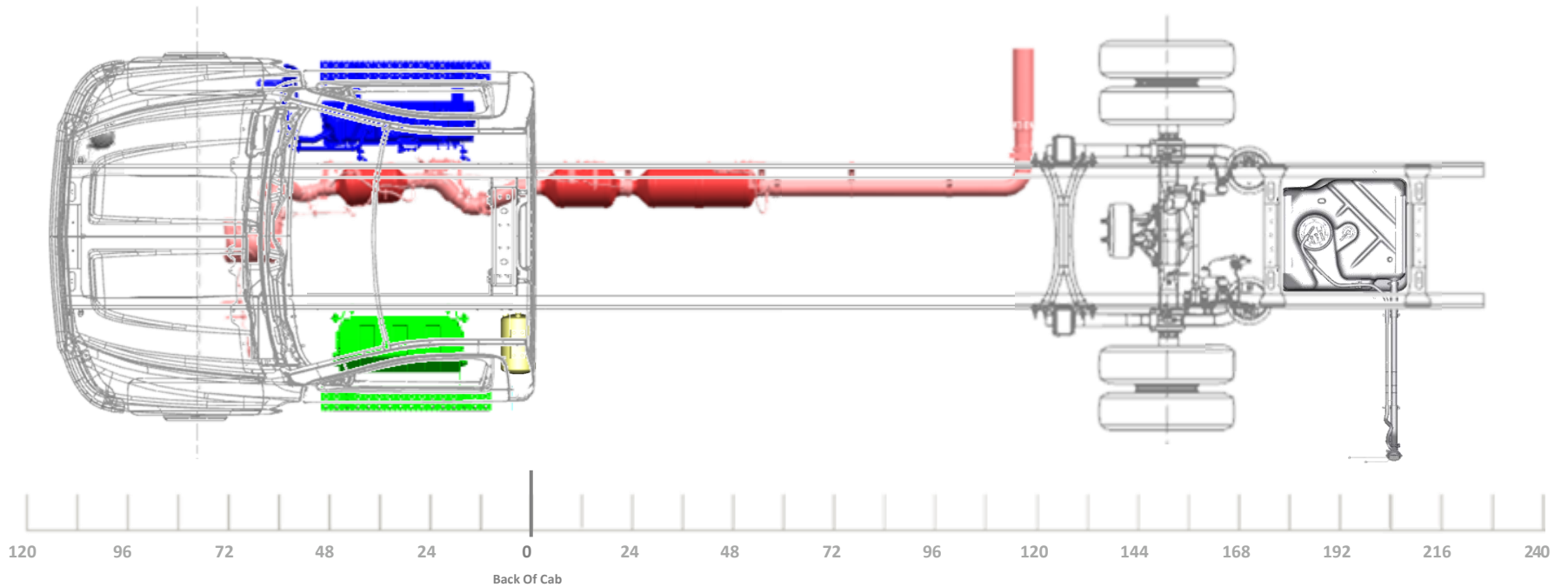

LAST REVISION: 9/25/2023

Model/Feature Information

Model:		C56403 K56403
Cab:		REGULAR CAB
Aftertreatment:		HORIZONTAL
Fuel Tank:	RPO N2L	40 GAL, AF MTD
Battery Box:	RPO 7Y9	TEMP MTD, 3 BATT
Air Tanks:		(1) OUTSIDE LEFT
DEF Tank:		6.75 GAL
Engine:		6.6L GM DURAMAX

General Configuration Information

4X2 OR 4X4 TRUCK CONFIGURATION
 VARI-RATE REAR SUSPENSION

SIDE EXIT TAILPIPE AHEAD OF REAR
 WHEELS, RT SIDE (RPO NPK)

OPTIONAL AIR DRYER FWD OUTSIDE
 RT (RPO KUT/JPY)

Minimum Wheelbase

231" WB (150" CA)
 91" AF

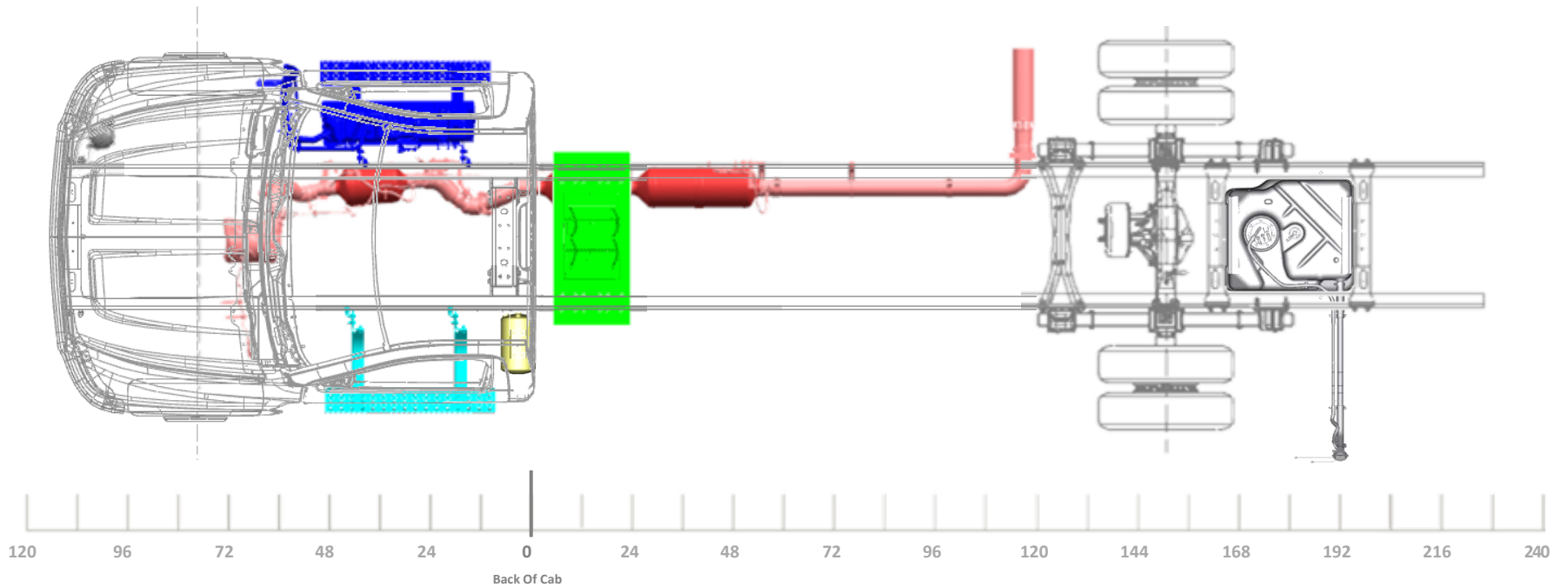

LAST REVISION: 9/25/2023

Model/Feature Information

Model:		C56403 K56403
Cab:		REGULAR CAB
Aftertreatment:		HORIZONTAL
Fuel Tank:	RPO N2L	40 GAL, AF MTD
Battery Box:	RPO 7Y9	TEMP MTD, 3 BATT
Air Tanks:		(1) OUTSIDE LEFT
DEF Tank:		6.75 GAL
Engine:		6.6L GM DURAMAX

General Configuration Information

4X2 TRUCK CONFIGURATION
 REAR AIR SUSPENSION
 SIDE EXIT TAILPIPE AHEAD OF REAR WHEELS, RT SIDE (RPO NPK)
 OPTIONAL AIR DRYER FWD OUTSIDE RT (RPO KUT/JPY)

Minimum Wheelbase

231" WB (150" CA)
 91" AF

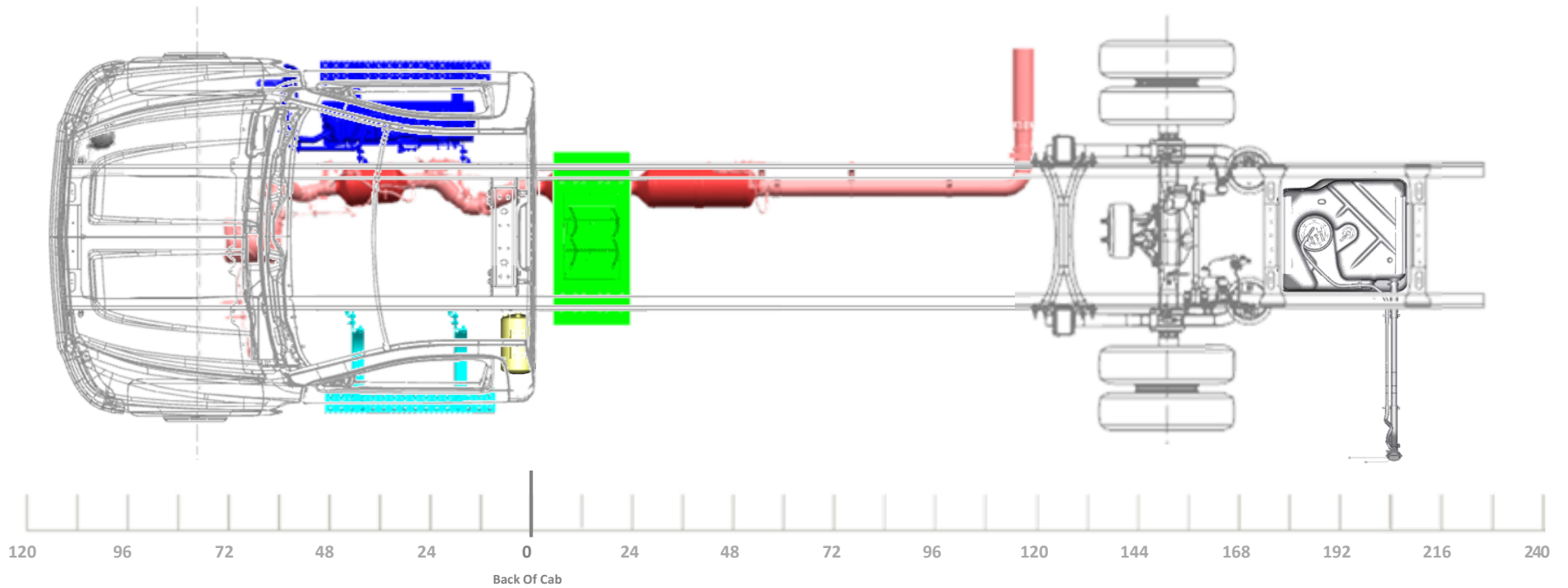

LAST REVISION: 9/25/2023

Model/Feature Information

Model:		C56403 K56403
Cab:		REGULAR CAB
Aftertreatment:		HORIZONTAL
Fuel Tank:	RPO NVK	25 GAL, CA MTD
Battery Box:	RPO 7Y7/7Y8	28" STEEL, 2 BATTERIES
Air Tanks:		(1) OUTSIDE LEFT
DEF Tank:		6.75 GAL
Engine:		6.6L GM DURAMAX

General Configuration Information

4X2 OR 4X4 TRUCK CONFIGURATION
 VARI-RATE REAR SUSPENSION

STRAIGHT TAILPIPE (RPO N12)

OPTIONAL AIR DRYER FWD OUTSIDE
 RT (RPO KUT/JPY)

Minimum Wheelbase

231" WB (150" CA)
 91" AF

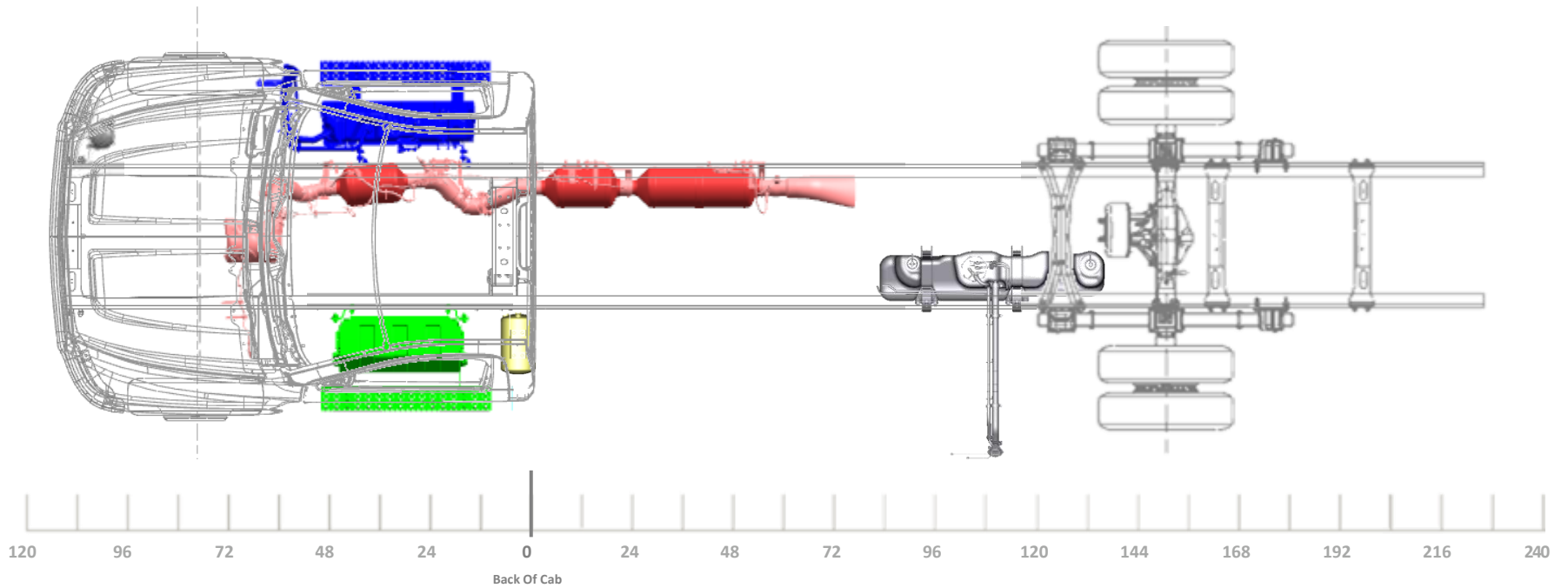

LAST REVISION: 9/25/2023

Model/Feature Information

Model:		C56403 K56403
Cab:		REGULAR CAB
Aftertreatment:		HORIZONTAL
Fuel Tank:	RPO NVK	25 GAL, CA MTD
Battery Box:	RPO 7Y7/7Y8	28" STEEL, 2 BATTERIES
Air Tanks:		(1) OUTSIDE LEFT
DEF Tank:		6.75 GAL
Engine:		6.6L GM DURAMAX

General Configuration Information

4X2 TRUCK CONFIGURATION
REAR AIR SUSPENSION
STRAIGHT TAILPIPE (RPO N12)
OPTIONAL AIR DRYER FWD OUTSIDE RT (RPO KUT/JPY)

Minimum Wheelbase

231" WB (150" CA)
91" AF

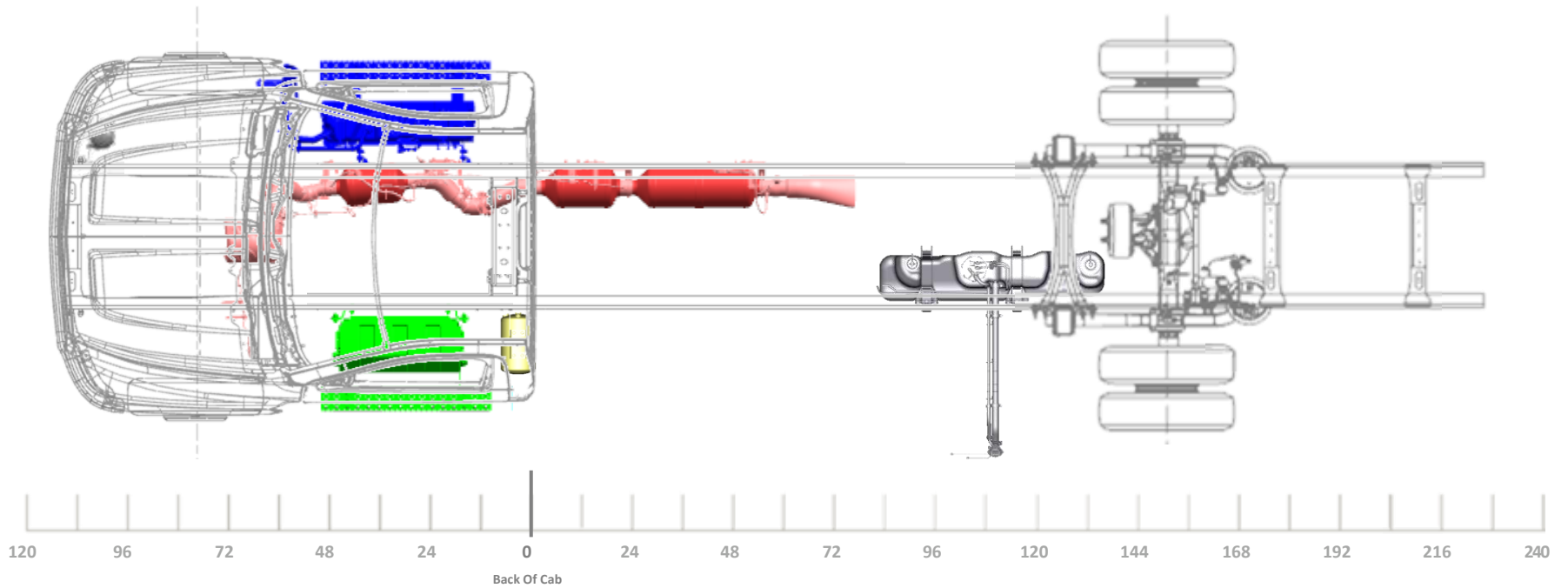

LAST REVISION: 9/25/2023

Model/Feature Information

Model:		C56403 K56403
Cab:		REGULAR CAB
Aftertreatment:		HORIZONTAL
Fuel Tank:	RPO NVK	25 GAL, CA MTD
Battery Box:	RPO 7Y9	TEMP MTD, 3 BATT
Air Tanks:		(1) OUTSIDE LEFT
DEF Tank:		6.75 GAL
Engine:		6.6L GM DURAMAX

General Configuration Information

4X2 OR 4X4 TRUCK CONFIGURATION
 VARI-RATE REAR SUSPENSION

STRAIGHT TAILPIPE (RPO N12)

OPTIONAL AIR DRYER FWD OUTSIDE
 RT (RPO KUT/JPY)

Minimum Wheelbase

231" WB (150" CA)
 91" AF

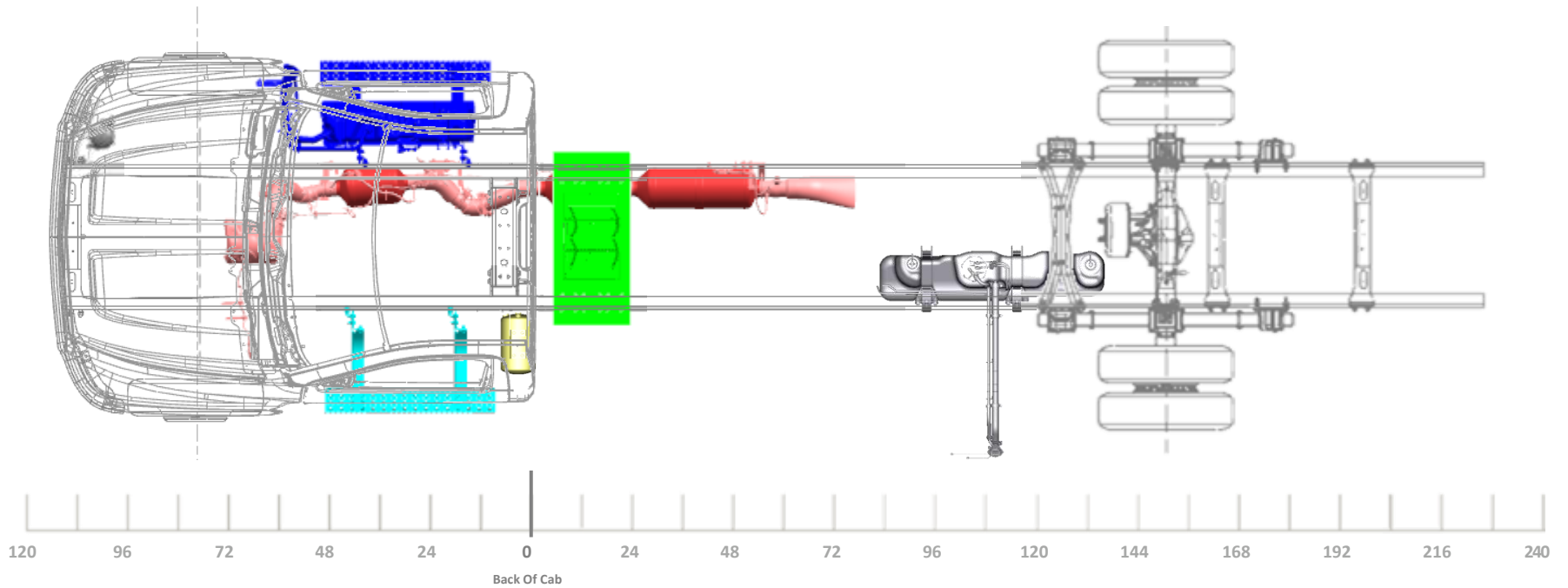

LAST REVISION: 9/25/2023

Model/Feature Information

Model:		C56403 K56403
Cab:		REGULAR CAB
Aftertreatment:		HORIZONTAL
Fuel Tank:	RPO NVK	25 GAL, CA MTD
Battery Box:	RPO 7Y9	TEMP MTD, 3 BATT
Air Tanks:		(1) OUTSIDE LEFT
DEF Tank:		6.75 GAL
Engine:		6.6L GM DURAMAX

General Configuration Information

4X2 TRUCK CONFIGURATION
REAR AIR SUSPENSION
STRAIGHT TAILPIPE (RPO N12)
OPTIONAL AIR DRYER FWD OUTSIDE RT (RPO KUT/JPY)

Minimum Wheelbase

231" WB (150" CA)
91" AF

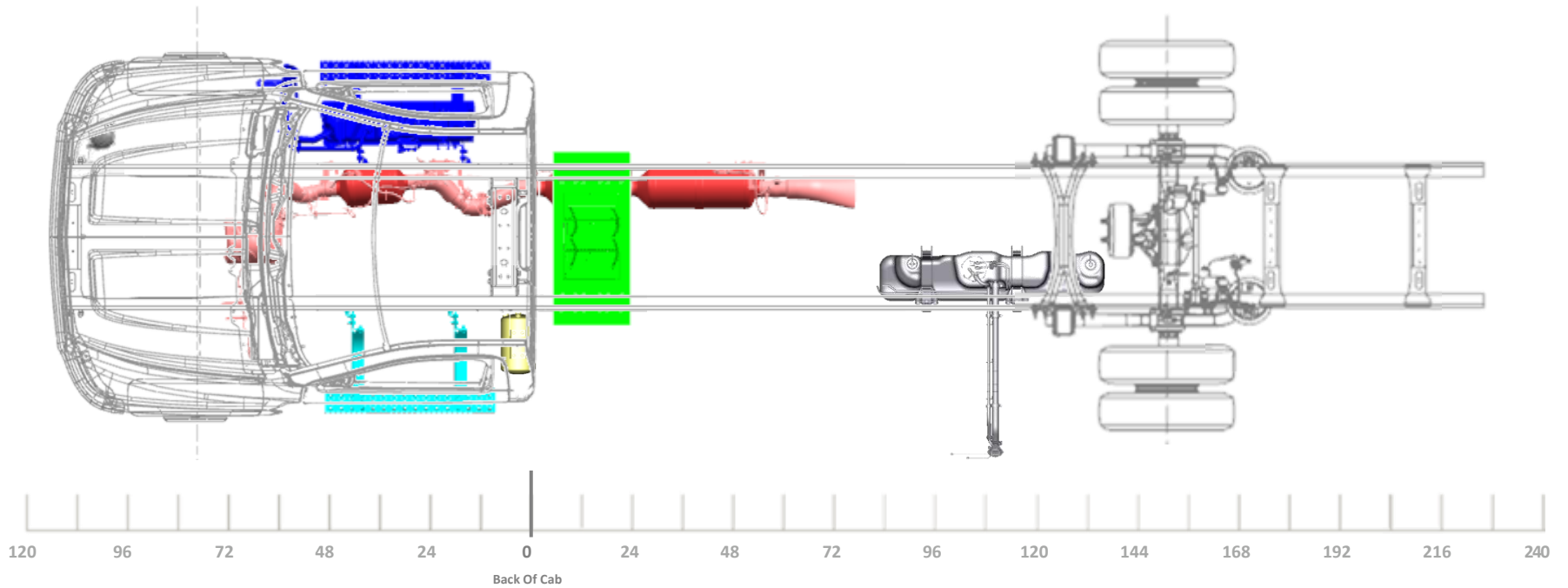

LAST REVISION: 9/25/2023

Model/Feature Information

Model:		C56403 K56403
Cab:		REGULAR CAB
Aftertreatment:		HORIZONTAL
Fuel Tank:	RPO NVK	25 GAL, CA MTD
Battery Box:	RPO 7Y7/7Y8	28" STEEL, 2 BATTERIES
Air Tanks:		(1) OUTSIDE LEFT
DEF Tank:		6.75 GAL
Engine:		6.6L GM DURAMAX

General Configuration Information

4X2 OR 4X4 TRUCK CONFIGURATION
VARI-RATE REAR SUSPENSION
SIDE EXIT TAILPIPE AHEAD OF REAR WHEELS, RT SIDE (RPO NPK)
OPTIONAL AIR DRYER FWD OUTSIDE RT (RPO KUT/JPY)

Minimum Wheelbase

231" WB (150" CA)
91" AF

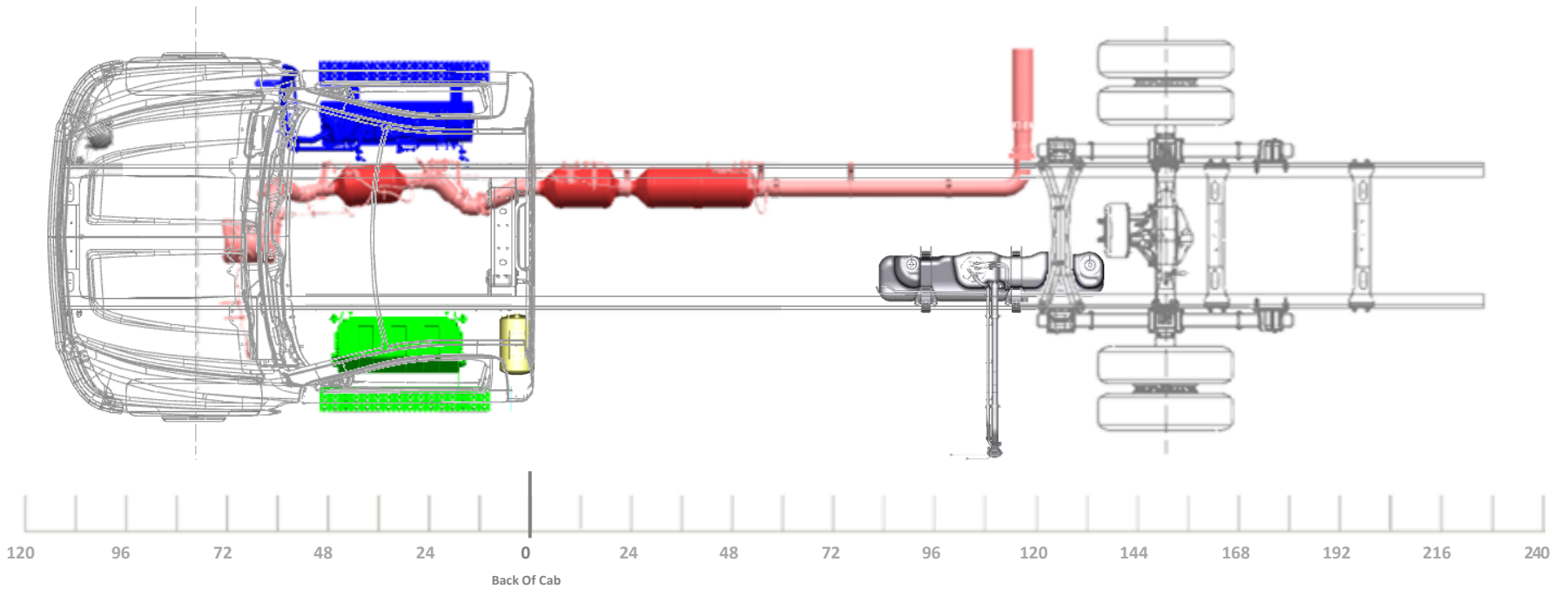

LAST REVISION: 9/25/2023

Model/Feature Information

Model:		C56403 K56403
Cab:		REGULAR CAB
Aftertreatment:		HORIZONTAL
Fuel Tank:	RPO NVK	25 GAL, CA MTD
Battery Box:	RPO 7Y7/7Y8	28" STEEL, 2 BATTERIES
Air Tanks:		(1) OUTSIDE LEFT
DEF Tank:		6.75 GAL
Engine:		6.6L GM DURAMAX

General Configuration Information

4X2 TRUCK CONFIGURATION
REAR AIR SUSPENSION
SIDE EXIT TAILPIPE AHEAD OF REAR WHEELS, RT SIDE (RPO NPK)
OPTIONAL AIR DRYER FWD OUTSIDE RT (RPO KUT/JPY)

Minimum Wheelbase

231" WB (150" CA)
91" AF

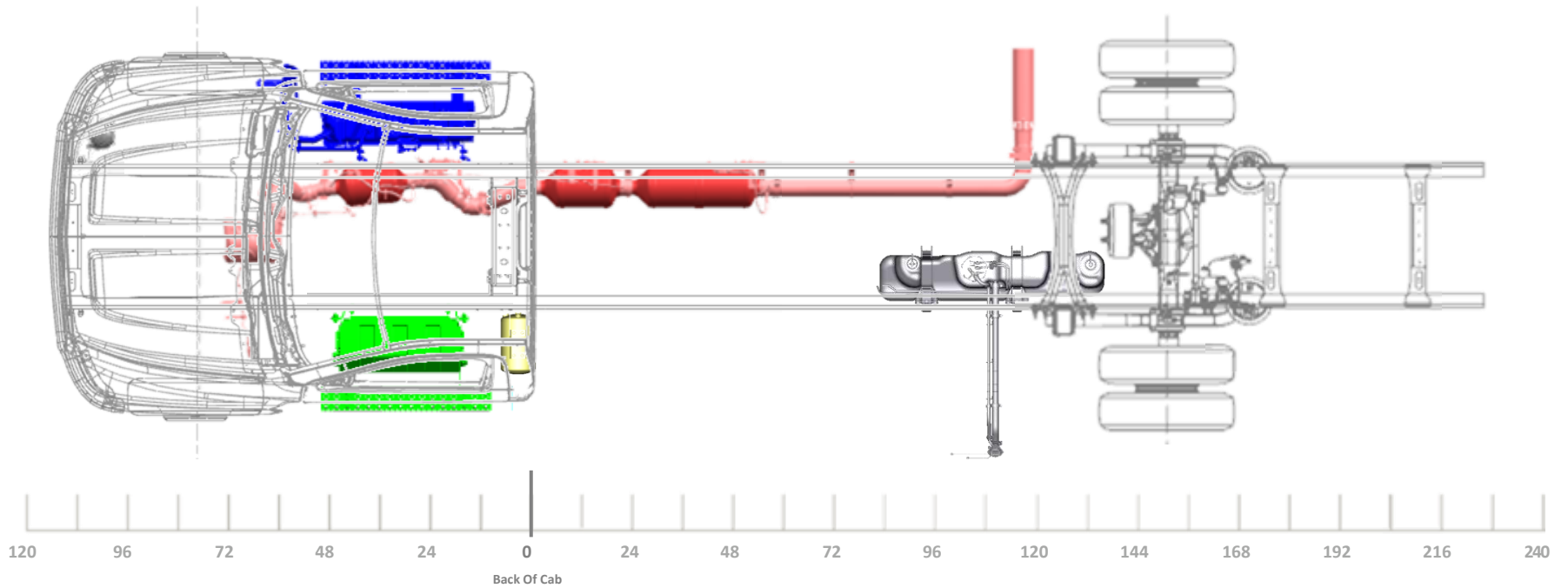

LAST REVISION: 9/25/2023

Model/Feature Information

Model:		C56403 K56403
Cab:		REGULAR CAB
Aftertreatment:		HORIZONTAL
Fuel Tank:	RPO NVK	25 GAL, CA MTD
Battery Box:	RPO 7Y9	TEMP MTD, 3 BATT
Air Tanks:		(1) OUTSIDE LEFT
DEF Tank:		6.75 GAL
Engine:		6.6L GM DURAMAX

General Configuration Information

4X2 OR 4X4 TRUCK CONFIGURATION
 VARI-RATE REAR SUSPENSION

SIDE EXIT TAILPIPE AHEAD OF REAR
 WHEELS, RT SIDE (RPO NPK)

OPTIONAL AIR DRYER FWD OUTSIDE
 RT (RPO KUT/JPY)

Minimum Wheelbase

231" WB (150" CA)
 91" AF

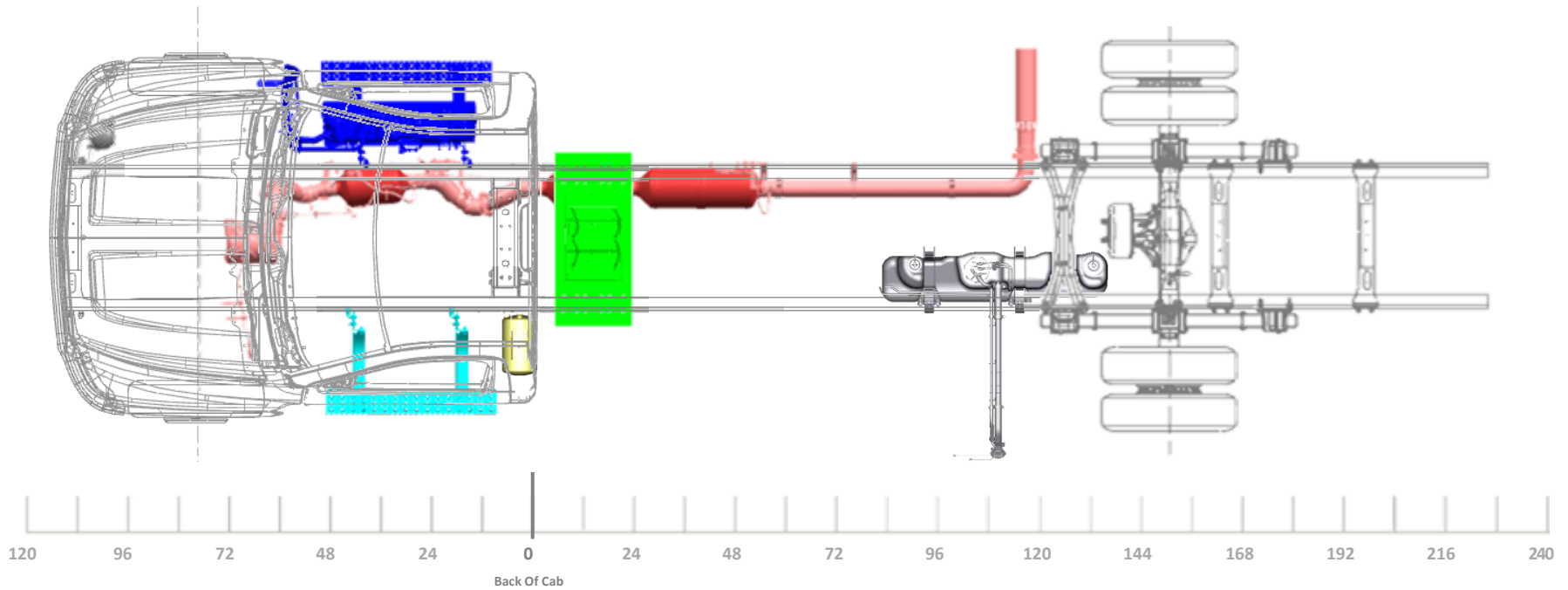

LAST REVISION: 9/25/2023

Model/Feature Information

Model:		C56403 K56403
Cab:		REGULAR CAB
Aftertreatment:		HORIZONTAL
Fuel Tank:	RPO NVK	25 GAL, CA MTD
Battery Box:	RPO 7Y9	TEMP MTD, 3 BATT
Air Tanks:		(1) OUTSIDE LEFT
DEF Tank:		6.75 GAL
Engine:		6.6L GM DURAMAX

General Configuration Information

4X2 TRUCK CONFIGURATION
 REAR AIR SUSPENSION
 SIDE EXIT TAILPIPE AHEAD OF REAR WHEELS, RT SIDE (RPO NPK)
 OPTIONAL AIR DRYER FWD OUTSIDE RT (RPO KUT/JPY)

Minimum Wheelbase

231" WB (150" CA)
 91" AF

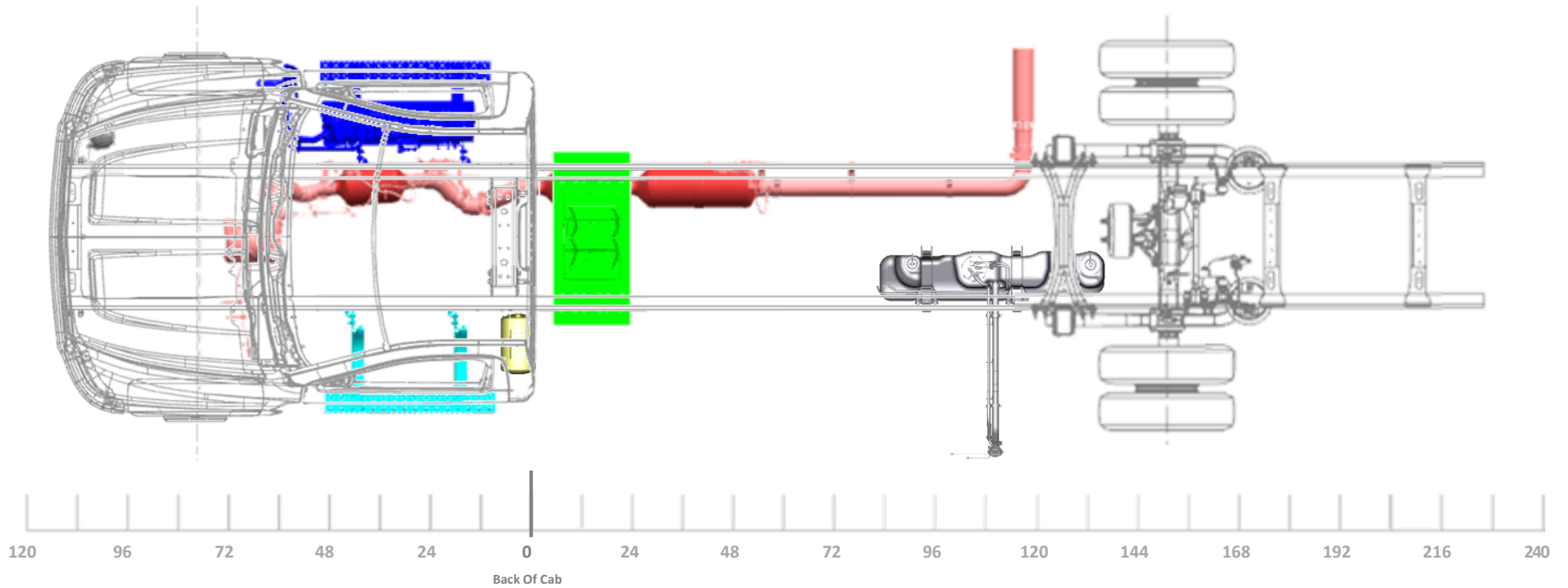

LAST REVISION: 9/25/2023

Model/Feature Information

Model:		C56403 K56403
Cab:		REGULAR CAB
Aftertreatment:		HORIZONTAL
Fuel Tank:	RPO NSQ	DUAL 25G CA, 40G AF
Battery Box:	RPO 7Y7/7Y8	28" STEEL, 2 BATTERIES
Air Tanks:		(1) OUTSIDE LEFT
DEF Tank:		6.75 GAL
Engine:		6.6L GM DURAMAX

General Configuration Information

4X2 OR 4X4 TRUCK CONFIGURATION
 VARI-RATE REAR SUSPENSION

STRAIGHT TAILPIPE (RPO N12)

OPTIONAL AIR DRYER FWD OUTSIDE
 RT (RPO KUT/JPY)

Minimum Wheelbase

231" WB (150" CA)
 91" AF

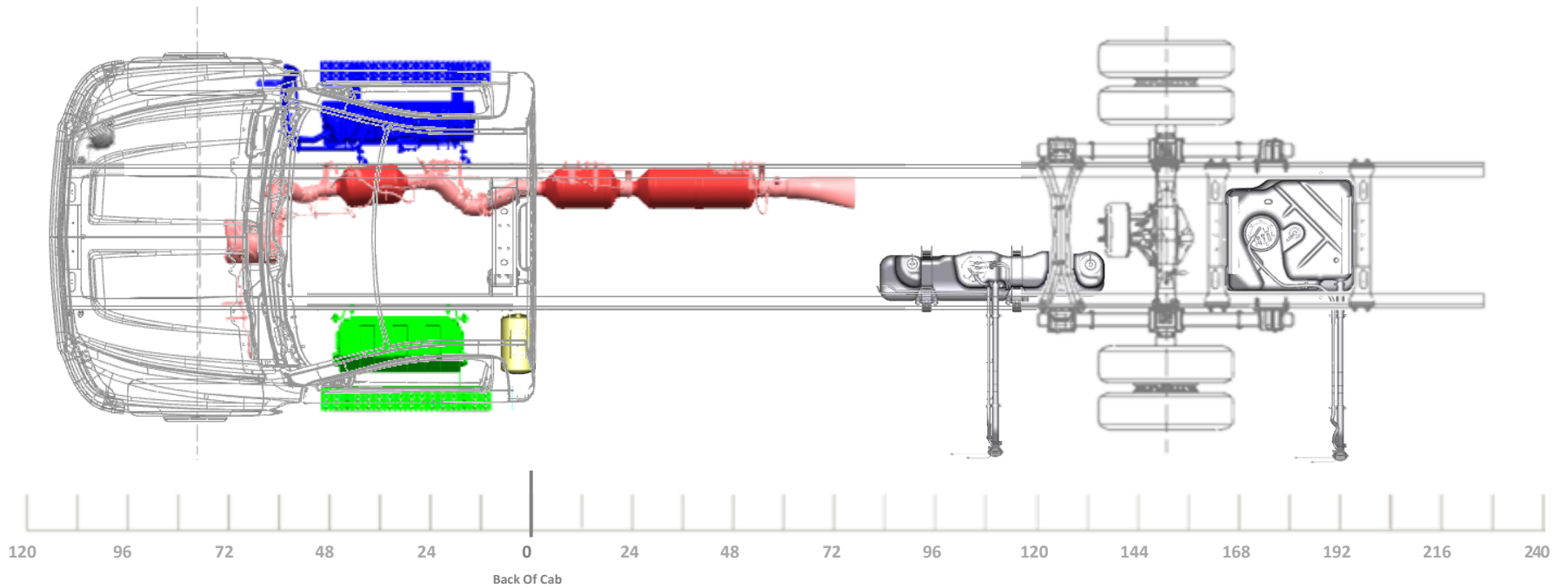

LAST REVISION: 9/25/2023

Model/Feature Information

Model:		C56403 K56403
Cab:		REGULAR CAB
Aftertreatment:		HORIZONTAL
Fuel Tank:	RPO NSQ	DUAL 25G CA, 40G AF
Battery Box:	RPO 7Y7/7Y8	28" STEEL, 2 BATTERIES
Air Tanks:		(1) OUTSIDE LEFT
DEF Tank:		6.75 GAL
Engine:		6.6L GM DURAMAX

General Configuration Information

4X2 TRUCK CONFIGURATION
REAR AIR SUSPENSION
STRAIGHT TAILPIPE (RPO N12)
OPTIONAL AIR DRYER FWD OUTSIDE RT (RPO KUT/JPY)

Minimum Wheelbase

231" WB (150" CA)
91" AF

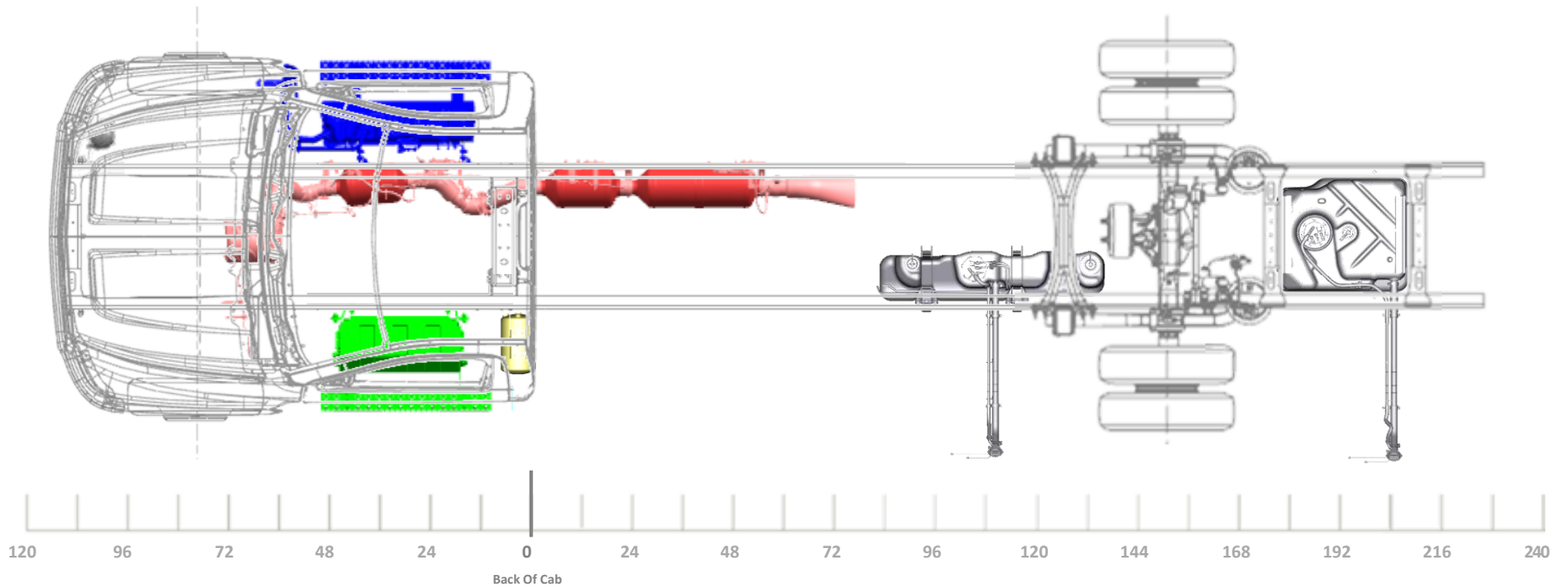

LAST REVISION: 9/25/2023

Model/Feature Information

Model:		C56403 K56403
Cab:		REGULAR CAB
Aftertreatment:		HORIZONTAL
Fuel Tank:	RPO NSQ	DUAL 25G CA, 40G AF
Battery Box:	RPO 7Y9	TEMP MTD, 3 BATT
Air Tanks:		(1) OUTSIDE LEFT
DEF Tank:		6.75 GAL
Engine:		6.6L GM DURAMAX

General Configuration Information

4X2 OR 4X4 TRUCK CONFIGURATION
 VARI-RATE REAR SUSPENSION

STRAIGHT TAILPIPE (RPO N12)

OPTIONAL AIR DRYER FWD OUTSIDE
 RT (RPO KUT/JPY)

Minimum Wheelbase

231" WB (150" CA)
 91" AF

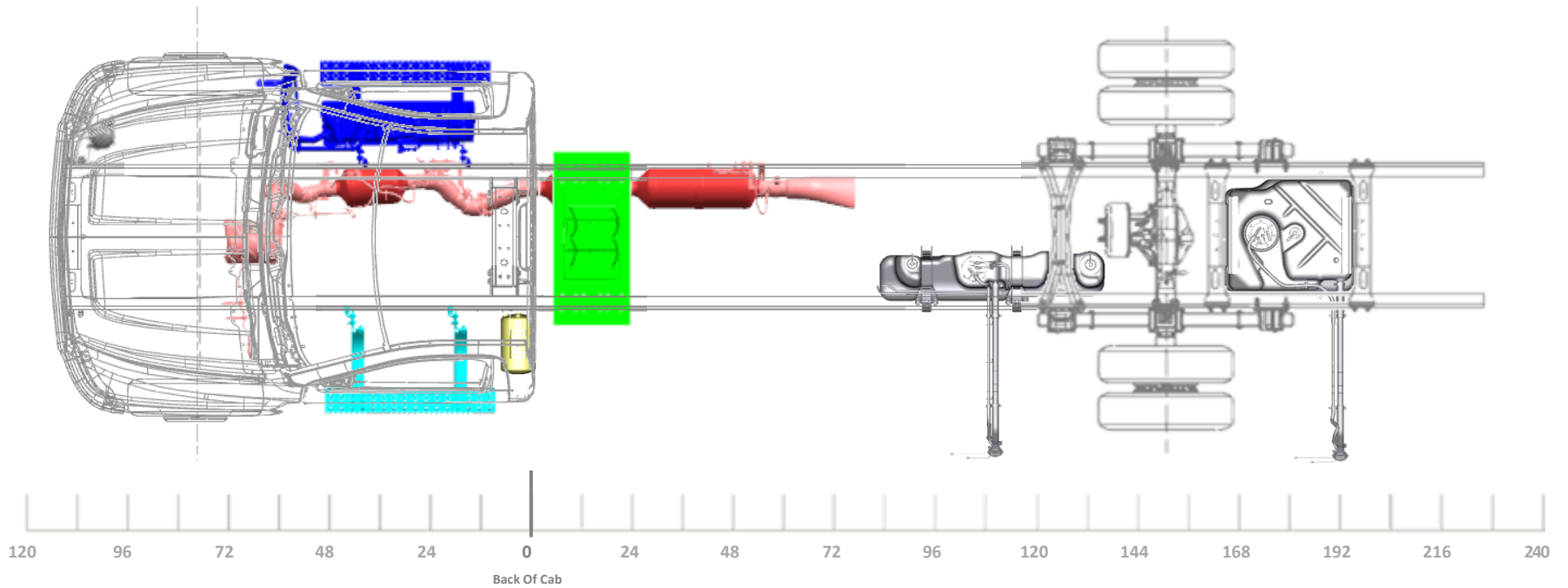

LAST REVISION: 9/25/2023

Model/Feature Information

Model:		C56403 K56403
Cab:		REGULAR CAB
Aftertreatment:		HORIZONTAL
Fuel Tank:	RPO NSQ	DUAL 25G CA, 40G AF
Battery Box:	RPO 7Y9	TEMP MTD, 3 BATT
Air Tanks:		(1) OUTSIDE LEFT
DEF Tank:		6.75 GAL
Engine:		6.6L GM DURAMAX

General Configuration Information

4X2 TRUCK CONFIGURATION
REAR AIR SUSPENSION
STRAIGHT TAILPIPE (RPO N12)
OPTIONAL AIR DRYER FWD OUTSIDE RT (RPO KUT/JPY)

Minimum Wheelbase

231" WB (150" CA)
91" AF

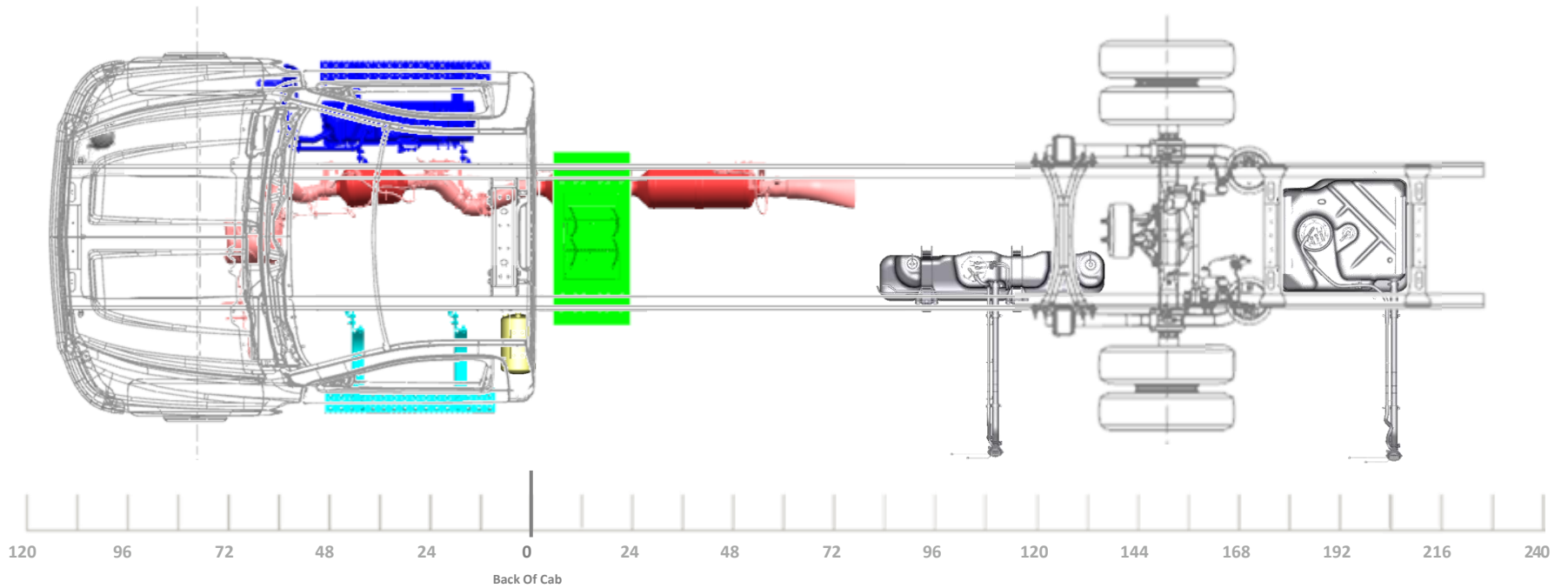

LAST REVISION: 9/25/2023

Model/Feature Information

Model:		C56403 K56403
Cab:		REGULAR CAB
Aftertreatment:		HORIZONTAL
Fuel Tank:	RPO NSQ	DUAL 25G CA, 40G AF
Battery Box:	RPO 7Y7/7Y8	28" STEEL, 2 BATTERIES
Air Tanks:		(1) OUTSIDE LEFT
DEF Tank:		6.75 GAL
Engine:		6.6L GM DURAMAX

General Configuration Information

4X2 OR 4X4 TRUCK CONFIGURATION
VARI-RATE REAR SUSPENSION

SIDE EXIT TAILPIPE AHEAD OF REAR WHEELS, RT SIDE (RPO NPK)

OPTIONAL AIR DRYER FWD OUTSIDE RT (RPO KUT/JPY)

Minimum Wheelbase

231" WB (150" CA)
91" AF

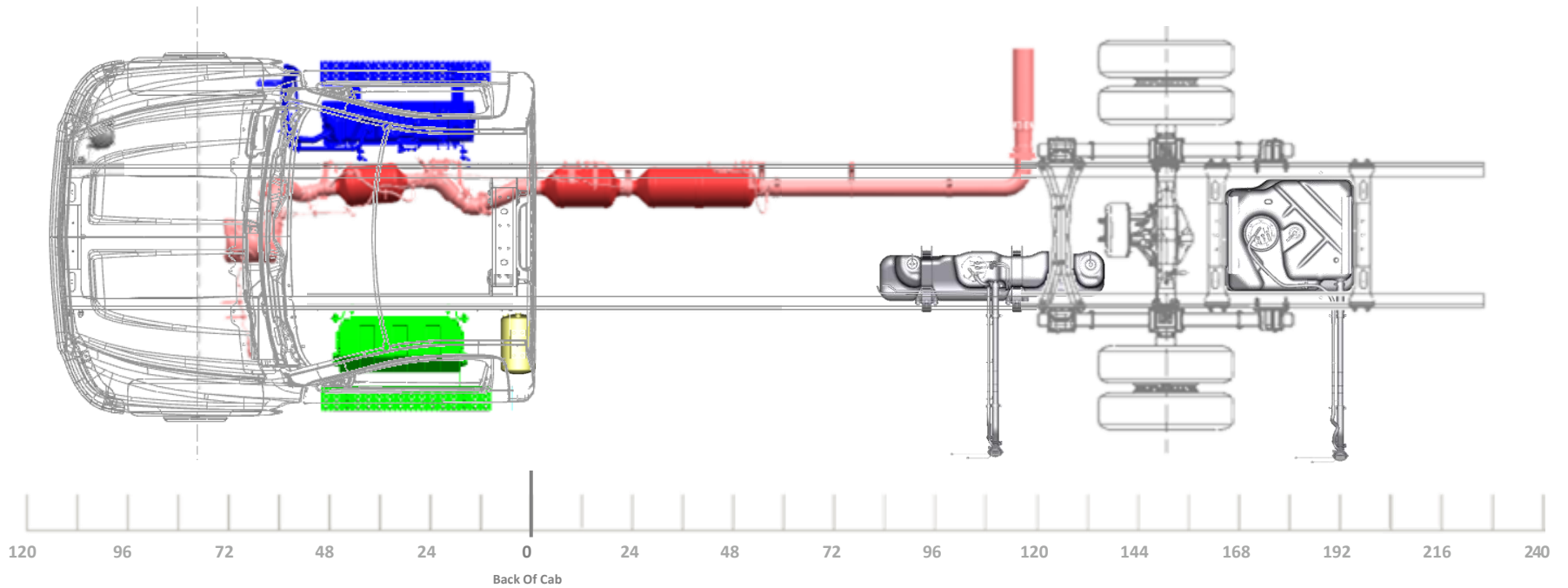

LAST REVISION: 9/25/2023

Model/Feature Information

Model:		C56403 K56403
Cab:		REGULAR CAB
Aftertreatment:		HORIZONTAL
Fuel Tank:	RPO NSQ	DUAL 25G CA, 40G AF
Battery Box:	RPO 7Y7/7Y8	28" STEEL, 2 BATTERIES
Air Tanks:		(1) OUTSIDE LEFT
DEF Tank:		6.75 GAL
Engine:		6.6L GM DURAMAX

General Configuration Information

4X2 TRUCK CONFIGURATION
REAR AIR SUSPENSION
SIDE EXIT TAILPIPE AHEAD OF REAR WHEELS, RT SIDE (RPO NPK)
OPTIONAL AIR DRYER FWD OUTSIDE RT (RPO KUT/JPY)

Minimum Wheelbase

231" WB (150" CA)
91" AF

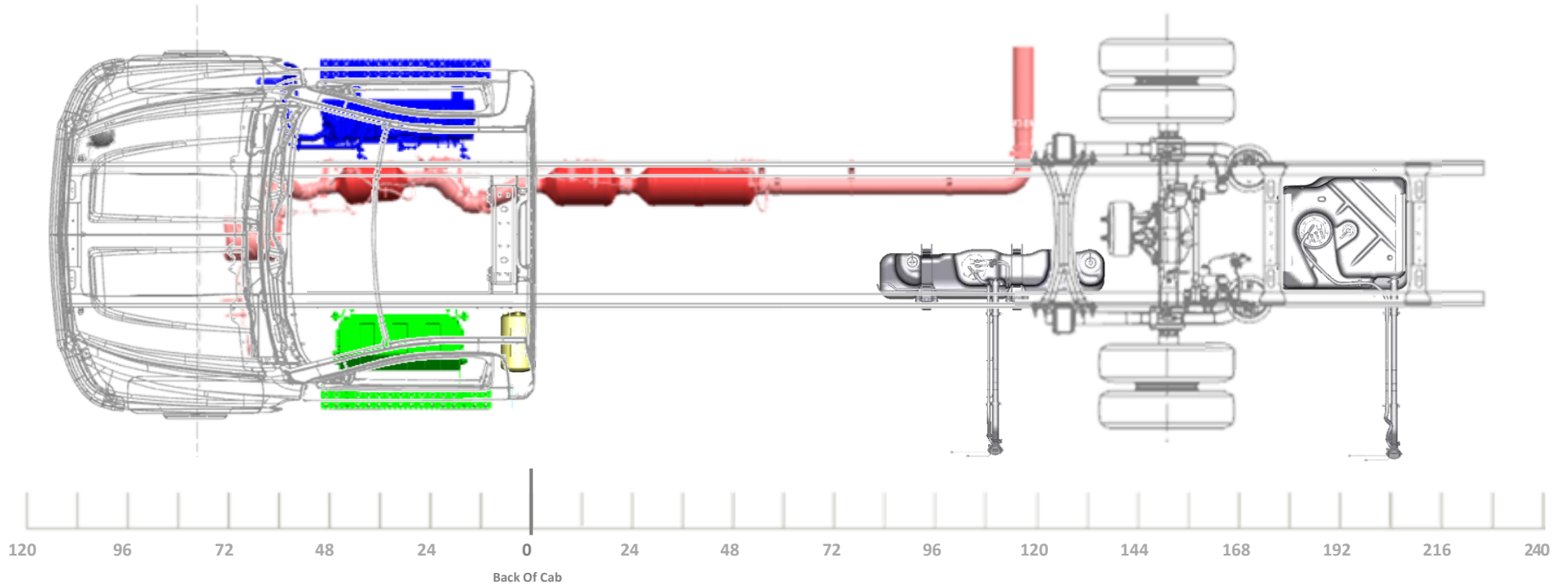

LAST REVISION: 9/25/2023

Model/Feature Information

Model:		C56403 K56403
Cab:		REGULAR CAB
Aftertreatment:		HORIZONTAL
Fuel Tank:	RPO NSQ	DUAL 25G CA, 40G AF
Battery Box:	RPO 7Y9	TEMP MTD, 3 BATT
Air Tanks:		(1) OUTSIDE LEFT
DEF Tank:		6.75 GAL
Engine:		6.6L GM DURAMAX

General Configuration Information

4X2 OR 4X4 TRUCK CONFIGURATION
 VARI-RATE REAR SUSPENSION

SIDE EXIT TAILPIPE AHEAD OF REAR
 WHEELS, RT SIDE (RPO NPK)

OPTIONAL AIR DRYER FWD OUTSIDE
 RT (RPO KUT/JPY)

Minimum Wheelbase

231" WB (150" CA)
 91" AF

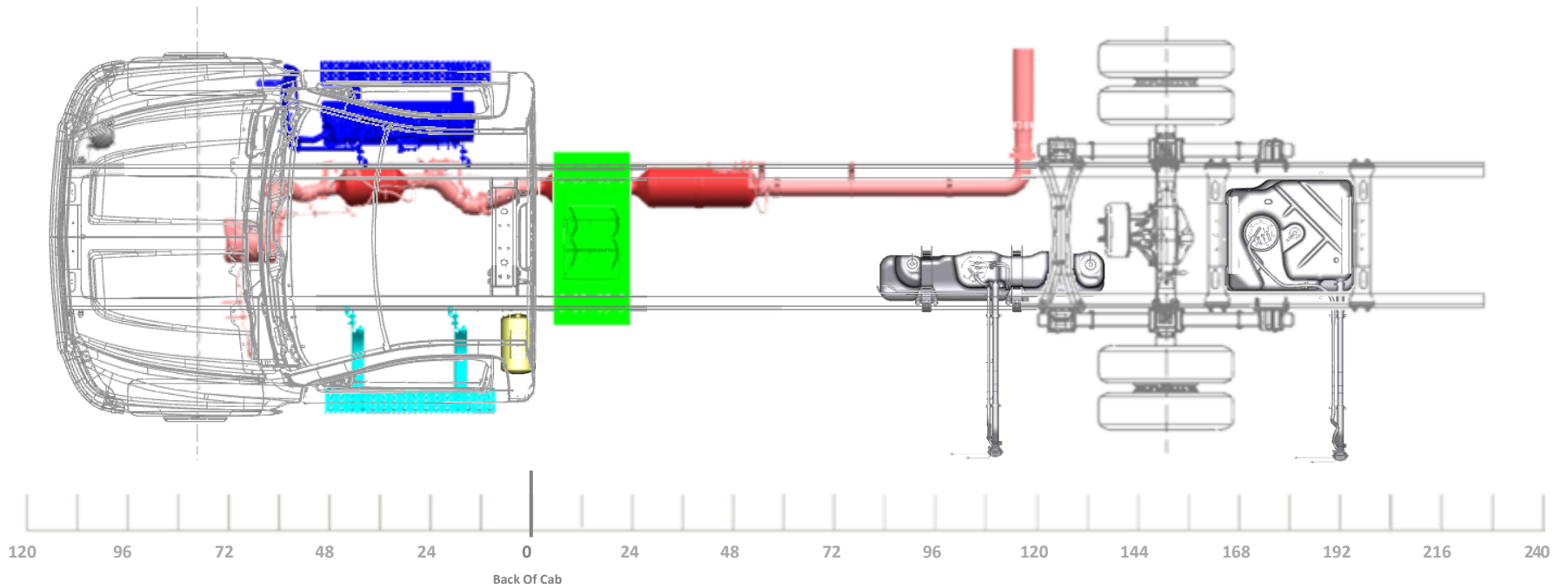

LAST REVISION: 9/25/2023

Model/Feature Information

Model:		C56403 K56403
Cab:		REGULAR CAB
Aftertreatment:		HORIZONTAL
Fuel Tank:	RPO NSQ	DUAL 25G CA, 40G AF
Battery Box:	RPO 7Y9	TEMP MTD, 3 BATT
Air Tanks:		(1) OUTSIDE LEFT
DEF Tank:		6.75 GAL
Engine:		6.6L GM DURAMAX

General Configuration Information

4X2 TRUCK CONFIGURATION
 REAR AIR SUSPENSION

SIDE EXIT TAILPIPE AHEAD OF REAR WHEELS, RT SIDE (RPO NPK)

OPTIONAL AIR DRYER FWD OUTSIDE RT (RPO KUT/JPY)

Minimum Wheelbase

231" WB (150" CA)
 91" AF

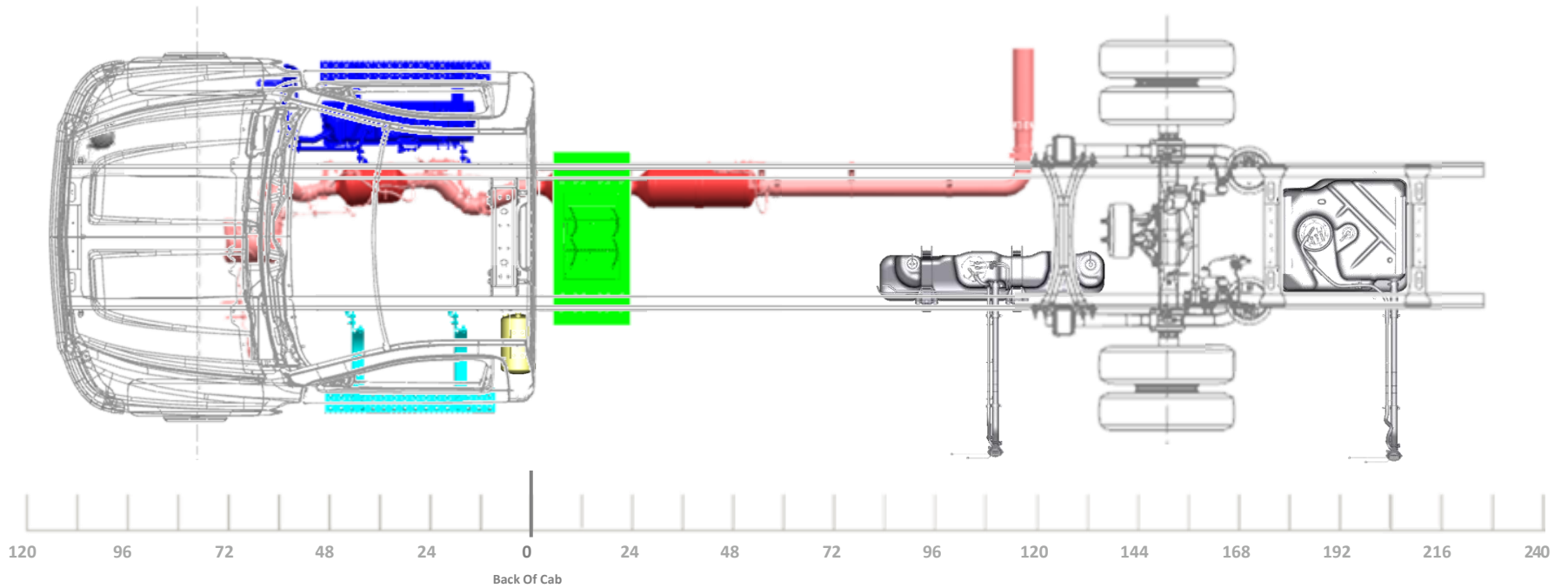

LAST REVISION: 9/25/2023

REGULAR
CAB 243"
WB

Model/Feature Information

Model:		C56403 K56403
Cab:		REGULAR CAB
Aftertreatment:		HORIZONTAL
Fuel Tank:	RPO N2L	40 GAL, AF MTD
Battery Box:	RPO 7Y7/7Y8	28" STEEL, 2 BATTERIES
Air Tanks:		(1) OUTSIDE LEFT
DEF Tank:		6.75 GAL
Engine:		6.6L GM DURAMAX

General Configuration Information

4X2 OR 4X4 TRUCK CONFIGURATION
 VARI-RATE REAR SUSPENSION

STRAIGHT TAILPIPE (RPO N12)

OPTIONAL AIR DRYER FWD OUTSIDE
 RT (RPO KUT/JPY)

Minimum Wheelbase

243" WB (162" CA)
 83" AF

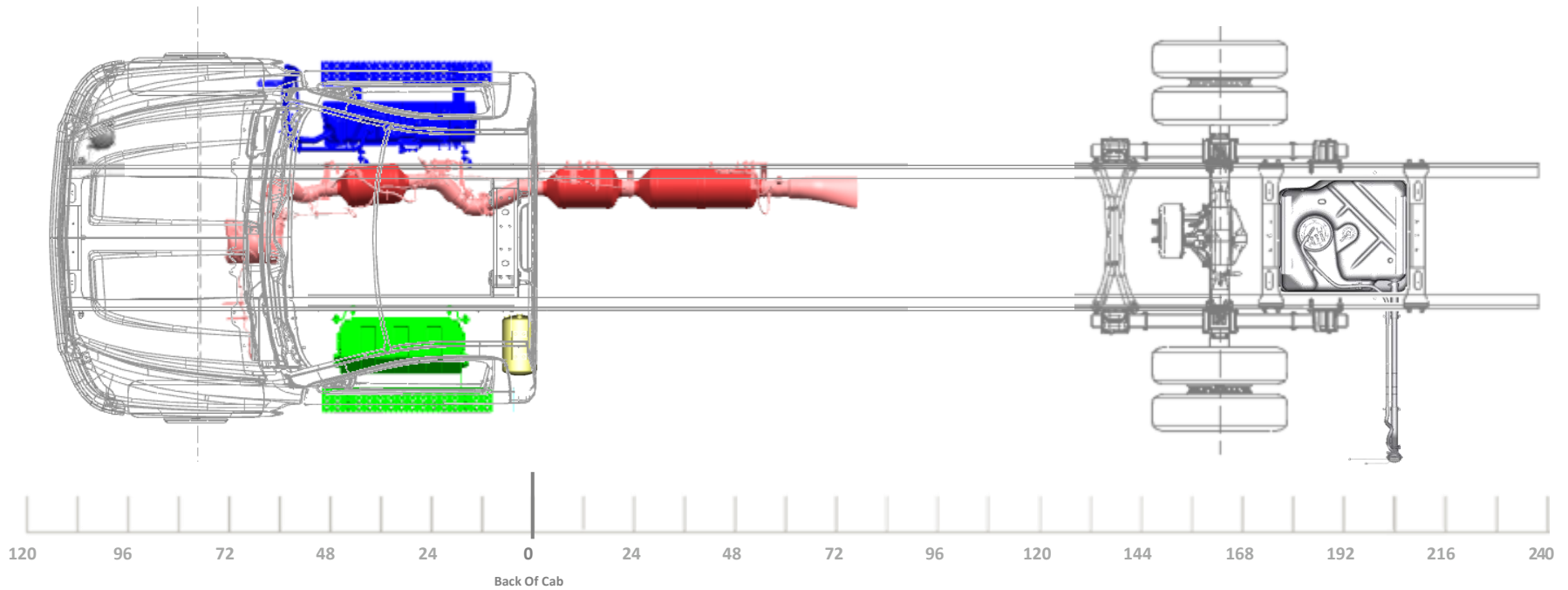

LAST REVISION: 9/25/2023

Model/Feature Information

Model:		C56403 K56403
Cab:		REGULAR CAB
Aftertreatment:		HORIZONTAL
Fuel Tank:	RPO N2L	40 GAL, AF MTD
Battery Box:	RPO 7Y7/7Y8	28" STEEL, 2 BATTERIES
Air Tanks:		(1) OUTSIDE LEFT
DEF Tank:		6.75 GAL
Engine:		6.6L GM DURAMAX

General Configuration Information

4X2 TRUCK CONFIGURATION
REAR AIR SUSPENSION
STRAIGHT TAILPIPE (RPO N12)
OPTIONAL AIR DRYER FWD OUTSIDE RT (RPO KUT/JPY)

Minimum Wheelbase

243" WB (162" CA)
83"AF

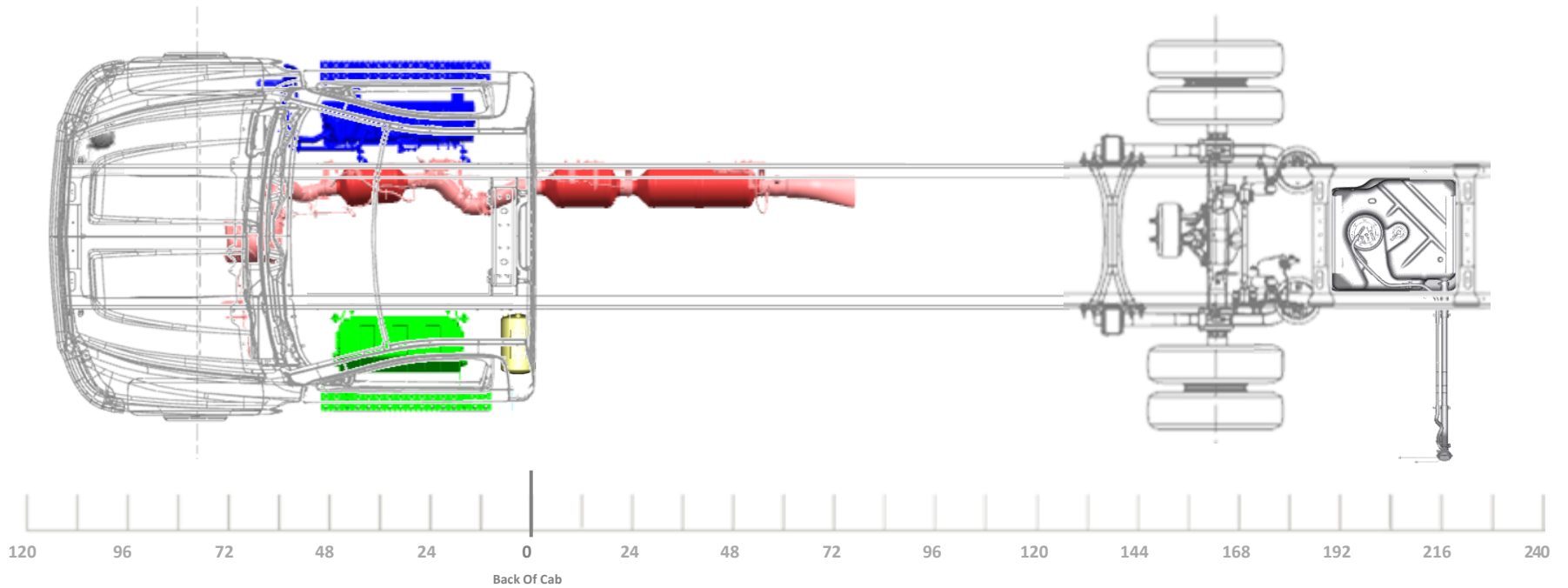

LAST REVISION: 9/25/2023

Model/Feature Information

Model:		C56403 K56403
Cab:		REGULAR CAB
Aftertreatment:		HORIZONTAL
Fuel Tank:	RPO N2L	40 GAL, AF MTD
Battery Box:	RPO 7Y9	TEMP MTD, 3 BATT
Air Tanks:		(1) OUTSIDE LEFT
DEF Tank:		6.75 GAL
Engine:		6.6L GM DURAMAX

General Configuration Information

4X2 OR 4X4 TRUCK CONFIGURATION
 VARI-RATE REAR SUSPENSION

STRAIGHT TAILPIPE (RPO N12)

OPTIONAL AIR DRYER FWD OUTSIDE
 RT (RPO KUT/JPY)

Minimum Wheelbase

243" WB (162" CA)
 83"AF

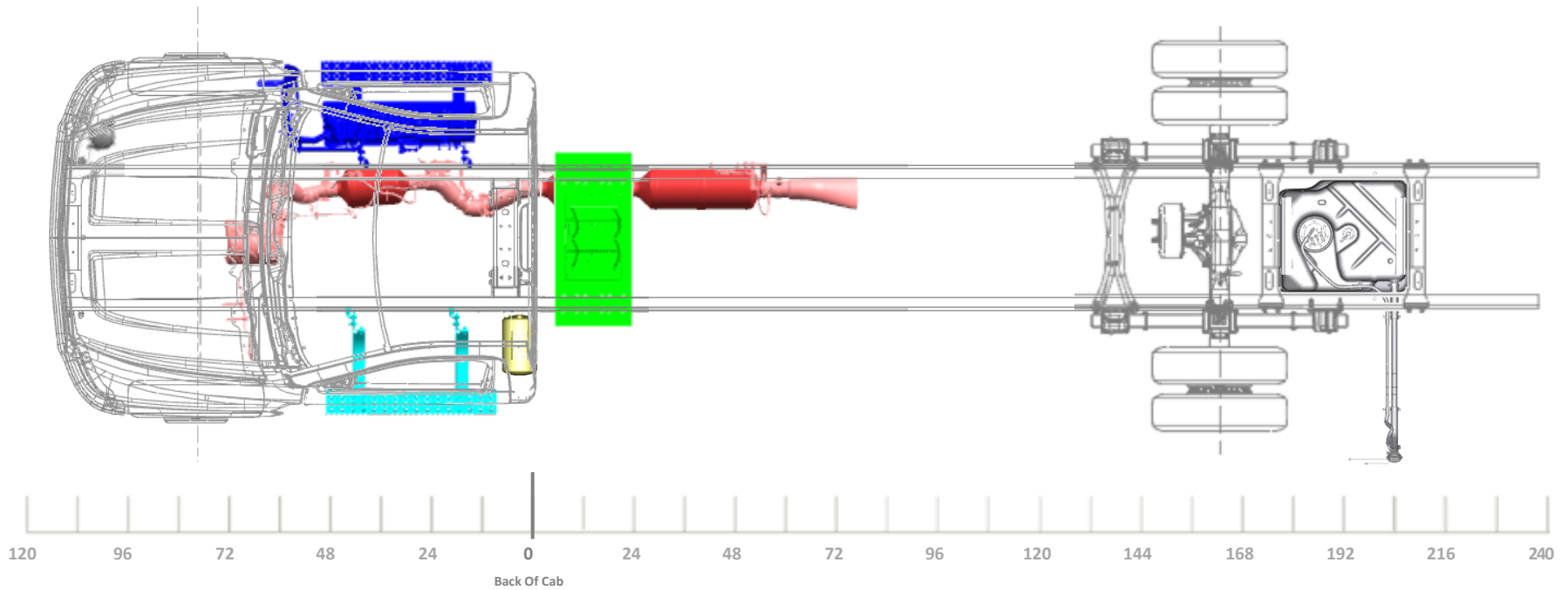

LAST REVISION: 9/25/2023

Model/Feature Information

Model:		C56403 K56403
Cab:		REGULAR CAB
Aftertreatment:		HORIZONTAL
Fuel Tank:	RPO N2L	40 GAL, AF MTD
Battery Box:	RPO 7Y9	TEMP MTD, 3 BATT
Air Tanks:		(1) OUTSIDE LEFT
DEF Tank:		6.75 GAL
Engine:		6.6L GM DURAMAX

General Configuration Information

4X2 TRUCK CONFIGURATION
REAR AIR SUSPENSION
STRAIGHT TAILPIPE (RPO N12)
OPTIONAL AIR DRYER FWD OUTSIDE RT (RPO KUT/JPY)

Minimum Wheelbase

243" WB (162" CA)
83"AF

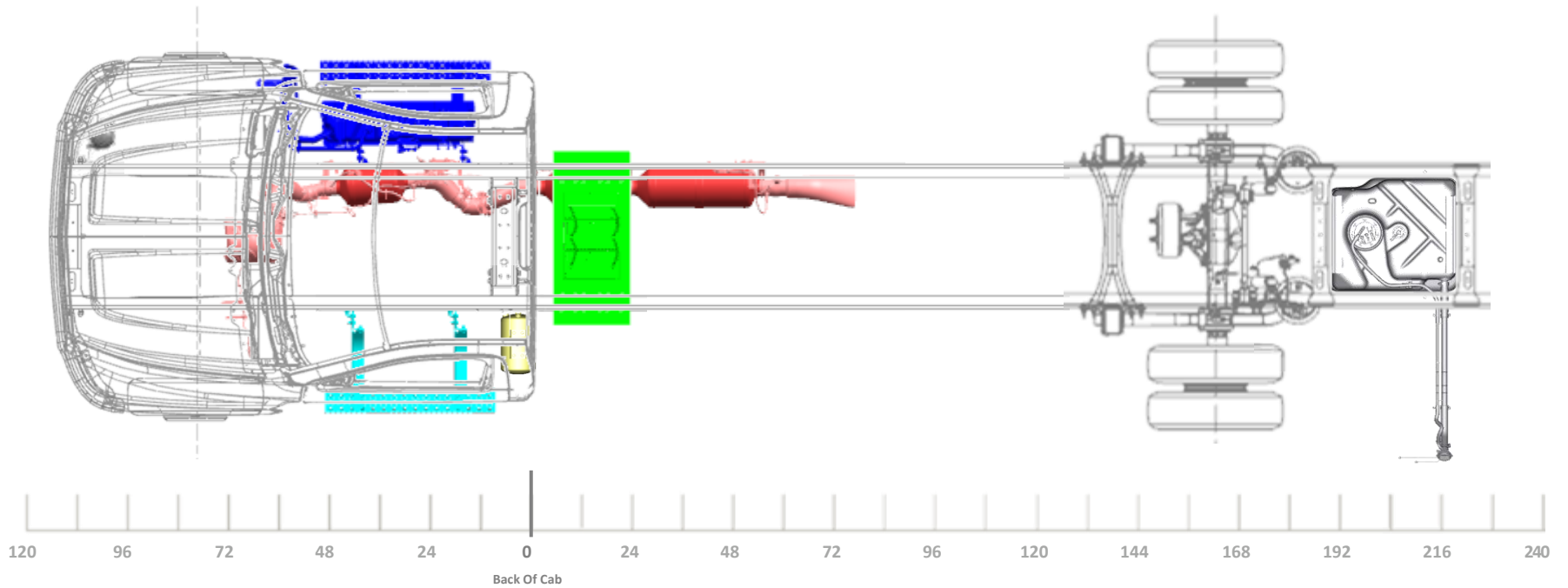

LAST REVISION: 9/25/2023

Model/Feature Information

Model:		C56403 K56403
Cab:		REGULAR CAB
Aftertreatment:		HORIZONTAL
Fuel Tank:	RPO N2L	40 GAL, AF MTD
Battery Box:	RPO 7Y7/7Y8	28" STEEL, 2 BATTERIES
Air Tanks:		(1) OUTSIDE LEFT
DEF Tank:		6.75 GAL
Engine:		6.6L GM DURAMAX

General Configuration Information

4X2 OR 4X4 TRUCK CONFIGURATION
VARI-RATE REAR SUSPENSION
SIDE EXIT TAILPIPE AHEAD OF REAR WHEELS, LT SIDE (RPO NPJ)
OPTIONAL AIR DRYER FWD OUTSIDE RT (RPO KUT/JPY)

Minimum Wheelbase

243" WB (162" CA)
83" AF

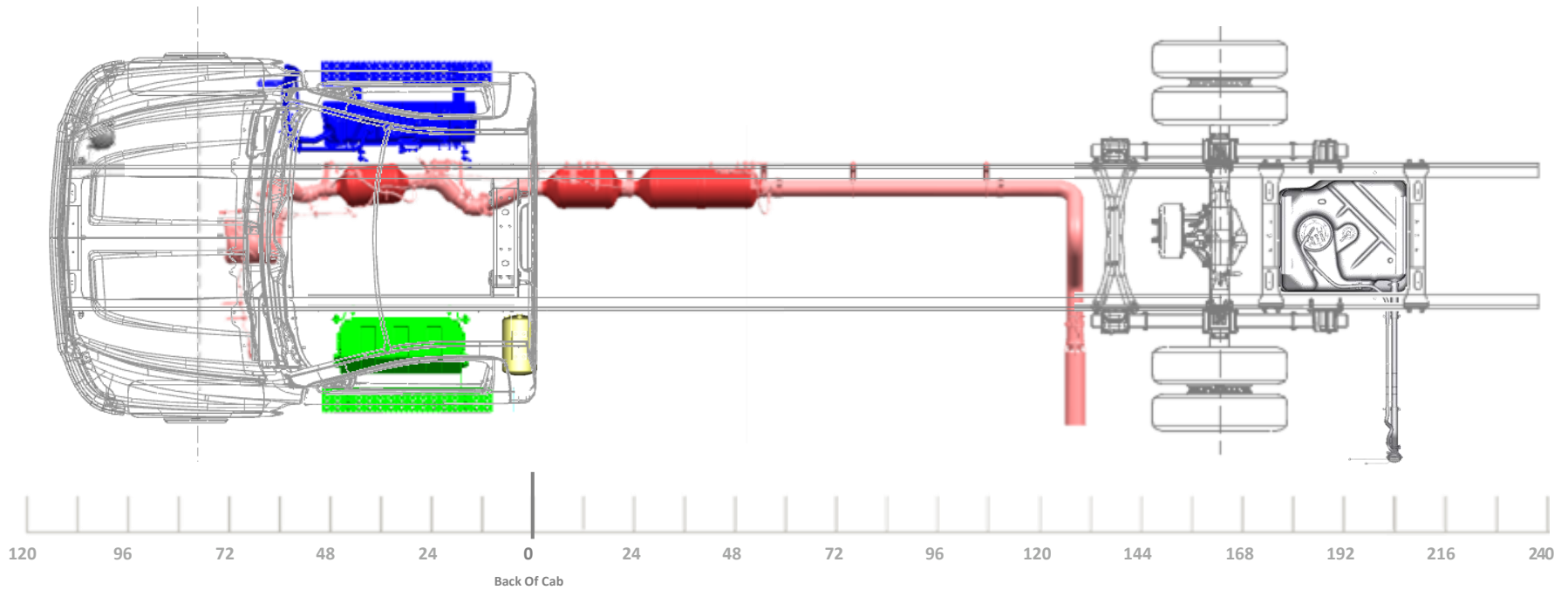

LAST REVISION: 9/25/2023

Model/Feature Information

Model:		C56403 K56403
Cab:		REGULAR CAB
Aftertreatment:		HORIZONTAL
Fuel Tank:	RPO N2L	40 GAL, AF MTD
Battery Box:	RPO 7Y7/7Y8	28" STEEL, 2 BATTERIES
Air Tanks:		(1) OUTSIDE LEFT
DEF Tank:		6.75 GAL
Engine:		6.6L GM DURAMAX

General Configuration Information

4X2 TRUCK CONFIGURATION
REAR AIR SUSPENSION
SIDE EXIT TAILPIPE AHEAD OF REAR WHEELS, LT SIDE (RPO NPJ)
OPTIONAL AIR DRYER FWD OUTSIDE RT (RPO KUT/JPY)

Minimum Wheelbase

243" WB (162" CA)
83"AF

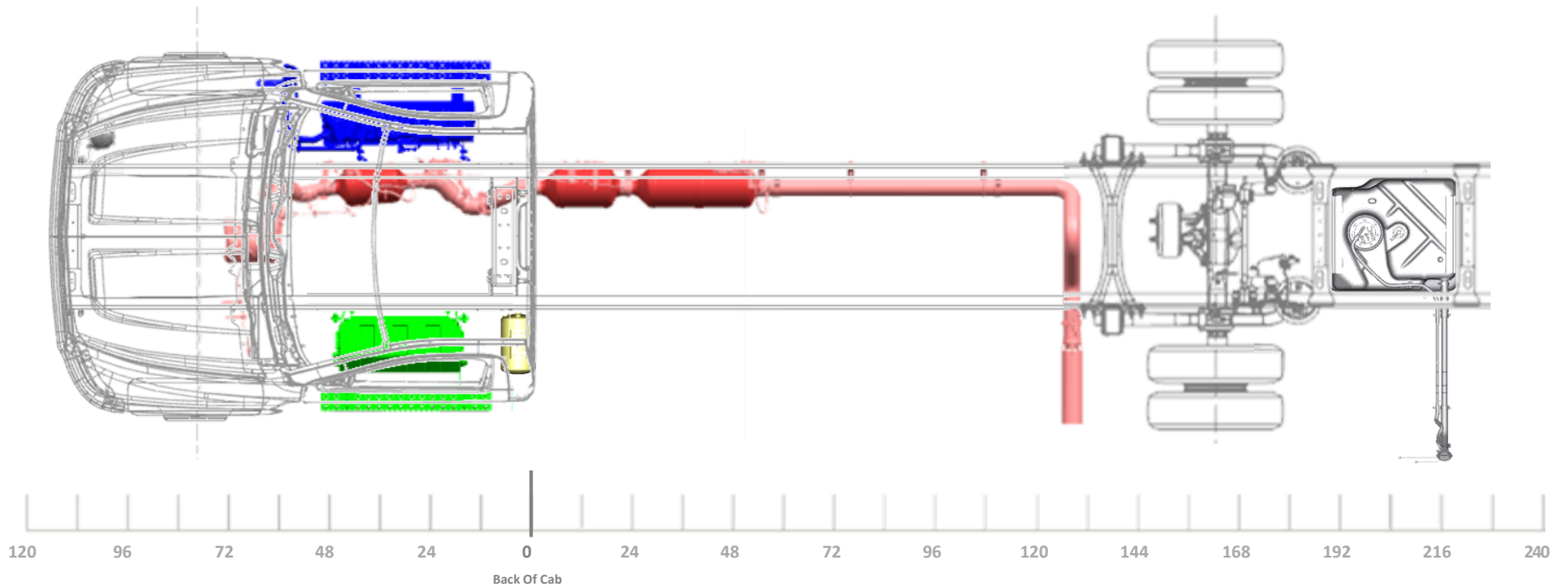

LAST REVISION: 9/25/2023

Model/Feature Information

Model:		C56403 K56403
Cab:		REGULAR CAB
Aftertreatment:		HORIZONTAL
Fuel Tank:	RPO N2L	40 GAL, AF MTD
Battery Box:	RPO 7Y9	TEMP MTD, 3 BATT
Air Tanks:		(1) OUTSIDE LEFT
DEF Tank:		6.75 GAL
Engine:		6.6L GM DURAMAX

General Configuration Information

4X2 OR 4X4 TRUCK CONFIGURATION
 VARI-RATE REAR SUSPENSION

SIDE EXIT TAILPIPE AHEAD OF REAR
 WHEELS, LT SIDE (RPO NPJ)

OPTIONAL AIR DRYER FWD OUTSIDE
 RT (RPO KUT/JPY)

Minimum Wheelbase

243" WB (162" CA)
 83"AF

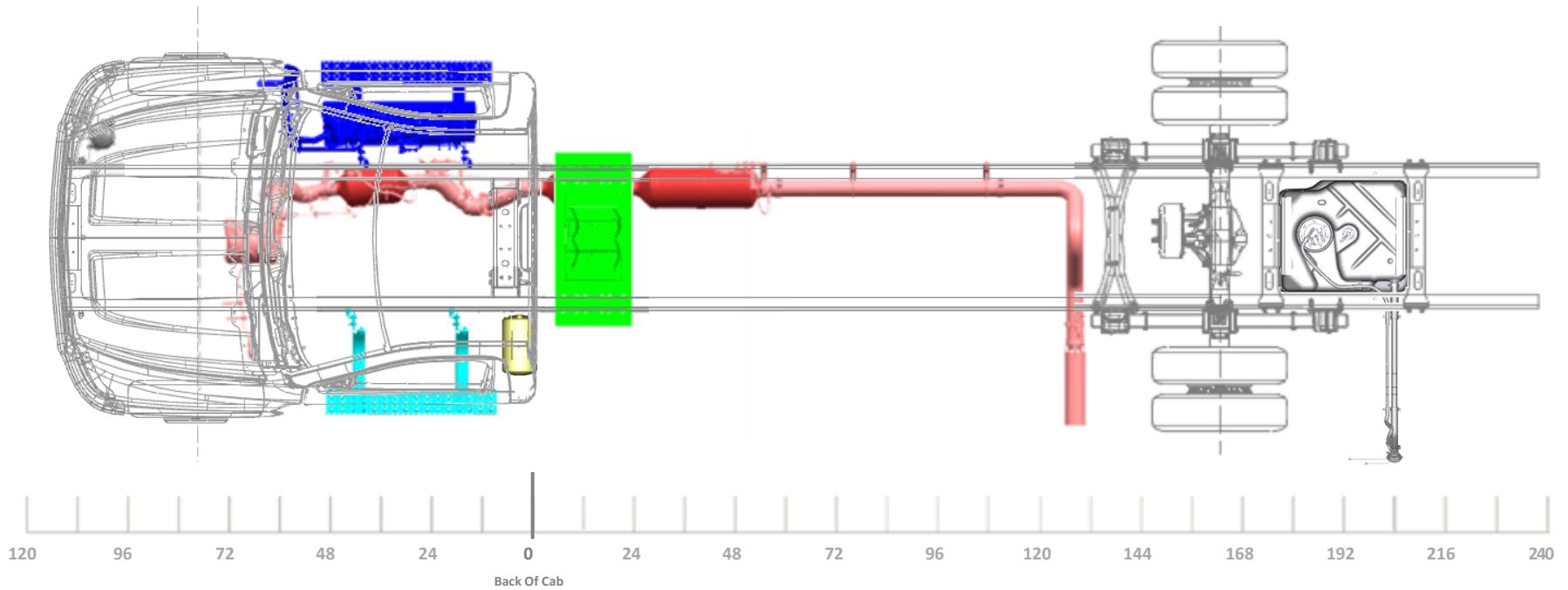

LAST REVISION: 9/25/2023

Model/Feature Information

Model:		C56403 K56403
Cab:		REGULAR CAB
Aftertreatment:		HORIZONTAL
Fuel Tank:	RPO N2L	40 GAL, AF MTD
Battery Box:	RPO 7Y9	TEMP MTD, 3 BATT
Air Tanks:		(1) OUTSIDE LEFT
DEF Tank:		6.75 GAL
Engine:		6.6L GM DURAMAX

General Configuration Information

4X2 TRUCK CONFIGURATION
 REAR AIR SUSPENSION
 SIDE EXIT TAILPIPE AHEAD OF REAR WHEELS, LT SIDE (RPO NPJ)
 OPTIONAL AIR DRYER FWD OUTSIDE RT (RPO KUT/JPY)

Minimum Wheelbase

243" WB (162" CA)
 83"AF

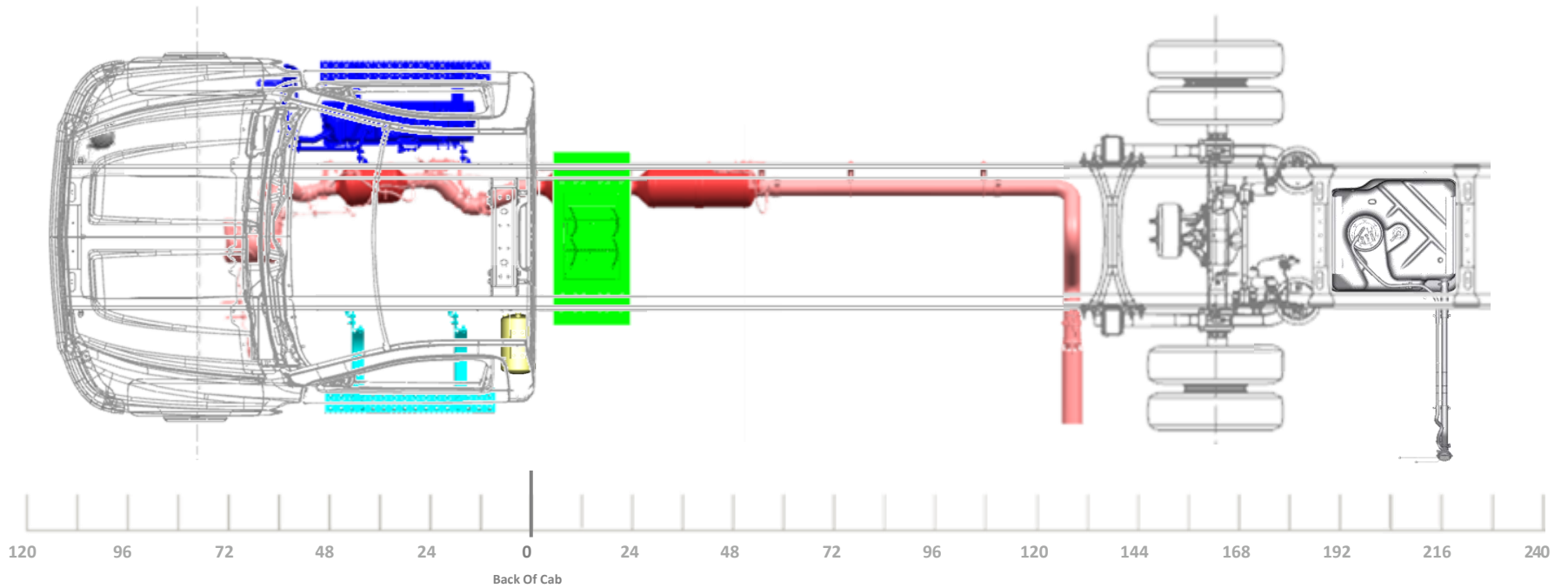

LAST REVISION: 9/25/2023

Model/Feature Information

Model:		C56403 K56403
Cab:		REGULAR CAB
Aftertreatment:		HORIZONTAL
Fuel Tank:	RPO N2L	40 GAL, AF MTD
Battery Box:	RPO 7Y7/7Y8	28" STEEL, 2 BATTERIES
Air Tanks:		(1) OUTSIDE LEFT
DEF Tank:		6.75 GAL
Engine:		6.6L GM DURAMAX

General Configuration Information

4X2 OR 4X4 TRUCK CONFIGURATION
 VARI-RATE REAR SUSPENSION
 SIDE EXIT TAILPIPE AHEAD OF REAR WHEELS, RT SIDE (RPO NPK)
 OPTIONAL AIR DRYER FWD OUTSIDE RT (RPO KUT/JPY)

Minimum Wheelbase

243" WB (162" CA)
 83" AF

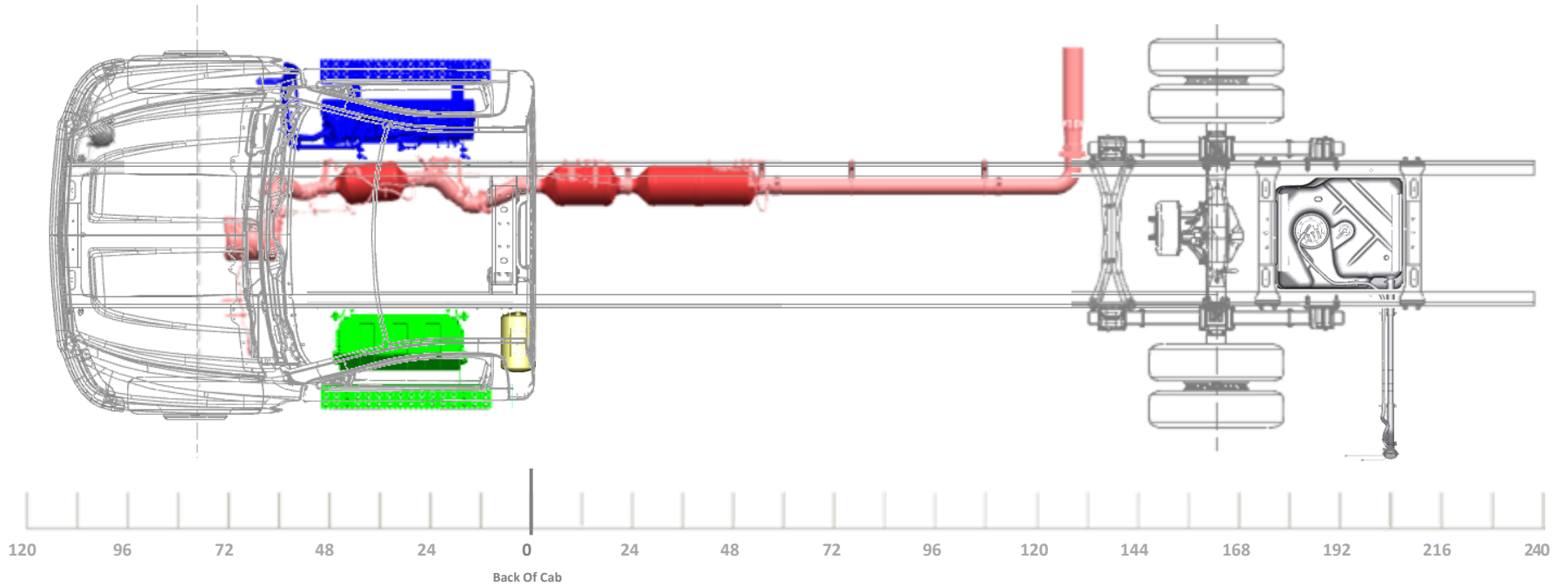

LAST REVISION: 9/25/2023

Model/Feature Information

Model:		C56403 K56403
Cab:		REGULAR CAB
Aftertreatment:		HORIZONTAL
Fuel Tank:	RPO N2L	40 GAL, AF MTD
Battery Box:	RPO 7Y7/7Y8	28" STEEL, 2 BATTERIES
Air Tanks:		(1) OUTSIDE LEFT
DEF Tank:		6.75 GAL
Engine:		6.6L GM DURAMAX

General Configuration Information

4X2 TRUCK CONFIGURATION
REAR AIR SUSPENSION
SIDE EXIT TAILPIPE AHEAD OF REAR WHEELS, RT SIDE (RPO NPK)
OPTIONAL AIR DRYER FWD OUTSIDE RT (RPO KUT/JPY)

Minimum Wheelbase

243" WB (162" CA)
83"AF

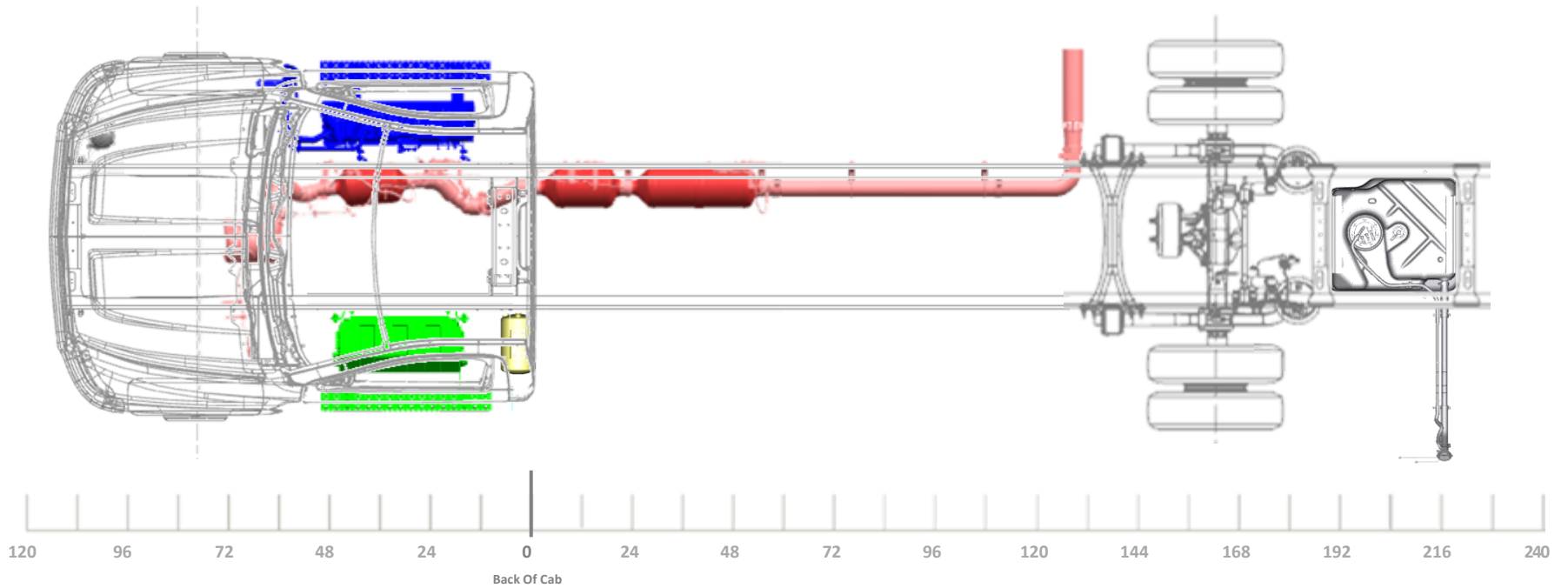

LAST REVISION: 9/25/2023

Model/Feature Information

Model:		C56403 K56403
Cab:		REGULAR CAB
Aftertreatment:		HORIZONTAL
Fuel Tank:	RPO N2L	40 GAL, AF MTD
Battery Box:	RPO 7Y9	TEMP MTD, 3 BATT
Air Tanks:		(1) OUTSIDE LEFT
DEF Tank:		6.75 GAL
Engine:		6.6L GM DURAMAX

General Configuration Information

4X2 OR 4X4 TRUCK CONFIGURATION
 VARI-RATE REAR SUSPENSION

SIDE EXIT TAILPIPE AHEAD OF REAR
 WHEELS, RT SIDE (RPO NPK)

OPTIONAL AIR DRYER FWD OUTSIDE
 RT (RPO KUT/JPY)

Minimum Wheelbase

243" WB (162" CA)
 83"AF

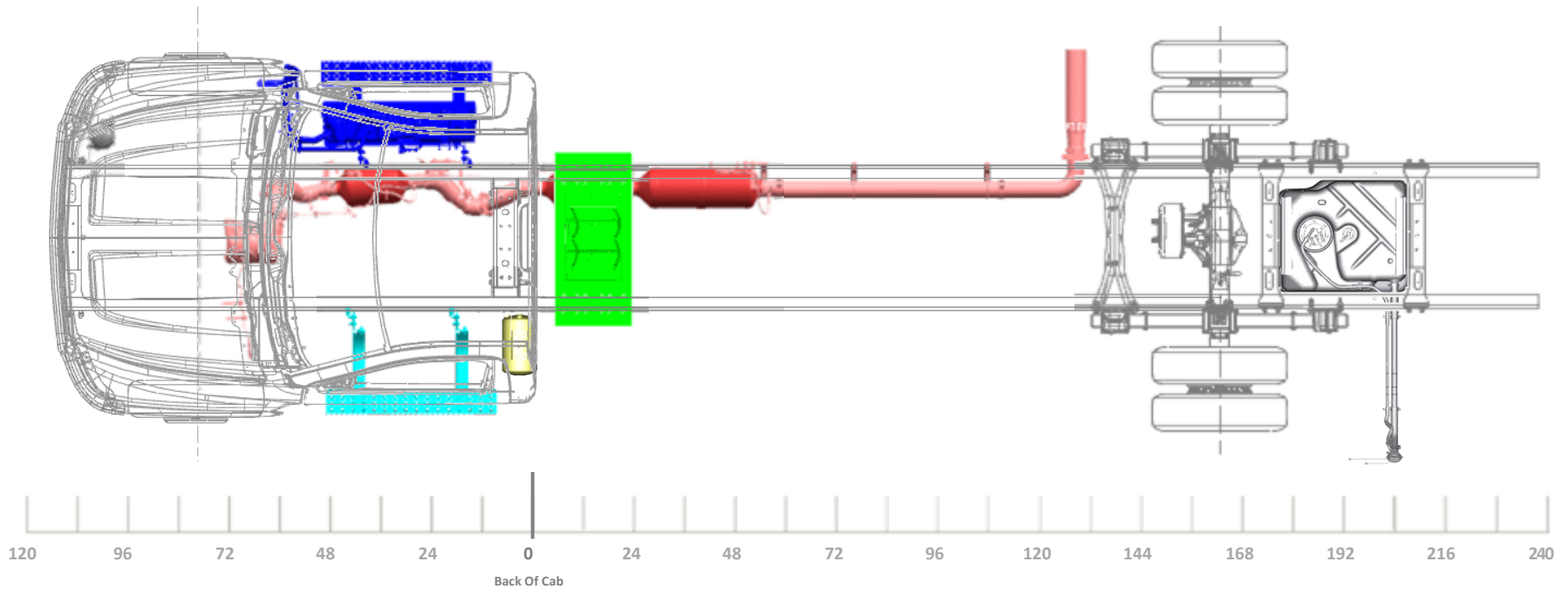

LAST REVISION: 9/25/2023

Model/Feature Information

Model:		C56403 K56403
Cab:		REGULAR CAB
Aftertreatment:		HORIZONTAL
Fuel Tank:	RPO N2L	40 GAL, AF MTD
Battery Box:	RPO 7Y9	TEMP MTD, 3 BATT
Air Tanks:		(1) OUTSIDE LEFT
DEF Tank:		6.75 GAL
Engine:		6.6L GM DURAMAX

General Configuration Information

4X2 TRUCK CONFIGURATION
REAR AIR SUSPENSION
SIDE EXIT TAILPIPE AHEAD OF REAR WHEELS, RT SIDE (RPO NPK)
OPTIONAL AIR DRYER FWD OUTSIDE RT (RPO KUT/JPY)

Minimum Wheelbase

243" WB (162" CA)
83"AF

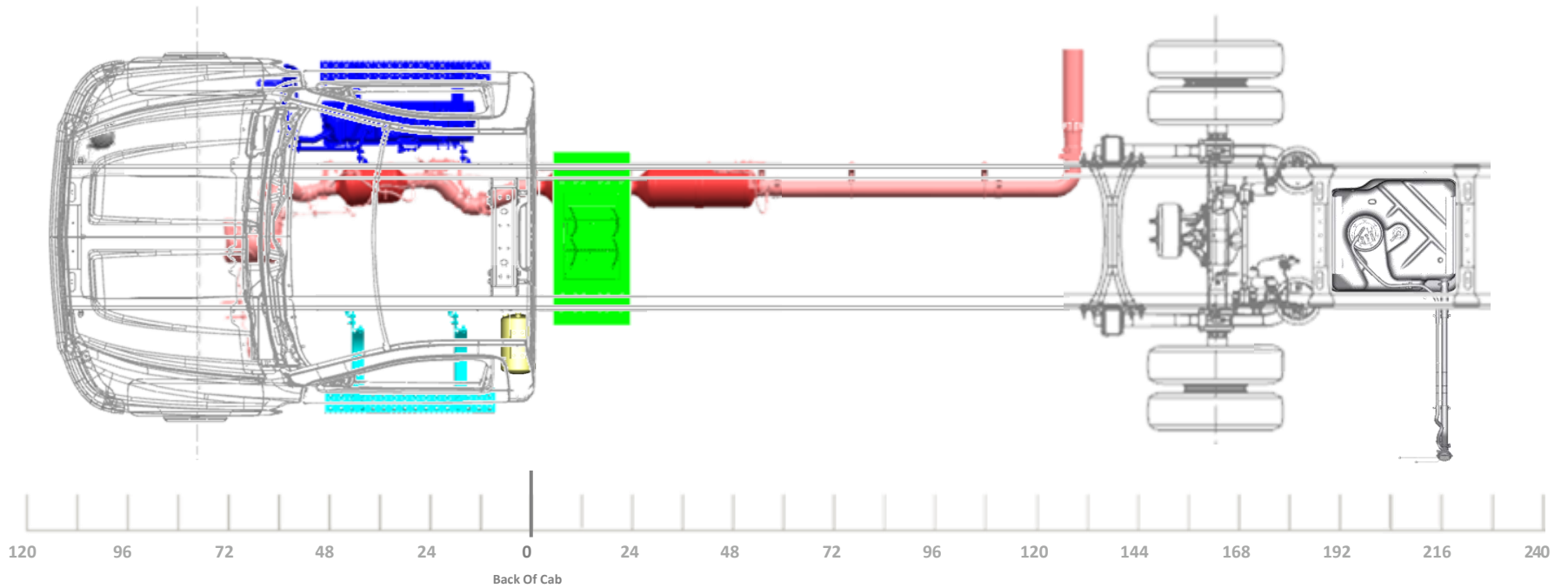

LAST REVISION: 9/25/2023

Model/Feature Information

Model:		C56403 K56403
Cab:		REGULAR CAB
Aftertreatment:		HORIZONTAL
Fuel Tank:	RPO NVK	25 GAL, CA MTD
Battery Box:	RPO 7Y7/7Y8	28" STEEL, 2 BATTERIES
Air Tanks:		(1) OUTSIDE LEFT
DEF Tank:		6.75 GAL
Engine:		6.6L GM DURAMAX

General Configuration Information

4X2 OR 4X4 TRUCK CONFIGURATION
VARI-RATE REAR SUSPENSION
STRAIGHT TAILPIPE (RPO N12)
OPTIONAL AIR DRYER FWD OUTSIDE RT (RPO KUT/JPY)

Minimum Wheelbase

243" WB (162" CA)
83" AF

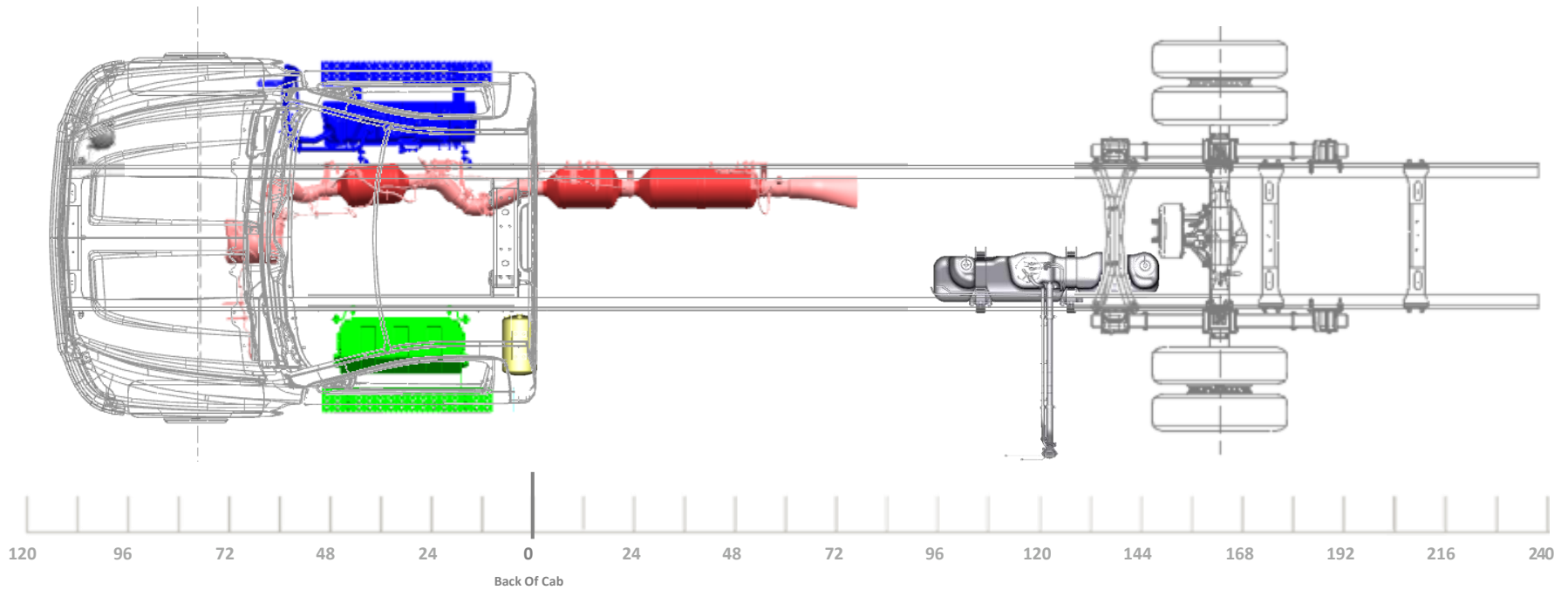

LAST REVISION: 9/25/2023

Model/Feature Information

Model:		C56403 K56403
Cab:		REGULAR CAB
Aftertreatment:		HORIZONTAL
Fuel Tank:	RPO NVK	25 GAL, CA MTD
Battery Box:	RPO 7Y7/7Y8	28" STEEL, 2 BATTERIES
Air Tanks:		(1) OUTSIDE LEFT
DEF Tank:		6.75 GAL
Engine:		6.6L GM DURAMAX

General Configuration Information

4X2 TRUCK CONFIGURATION
REAR AIR SUSPENSION
STRAIGHT TAILPIPE (RPO N12)
OPTIONAL AIR DRYER FWD OUTSIDE RT (RPO KUT/JPY)

Minimum Wheelbase

243" WB (162" CA)
83"AF

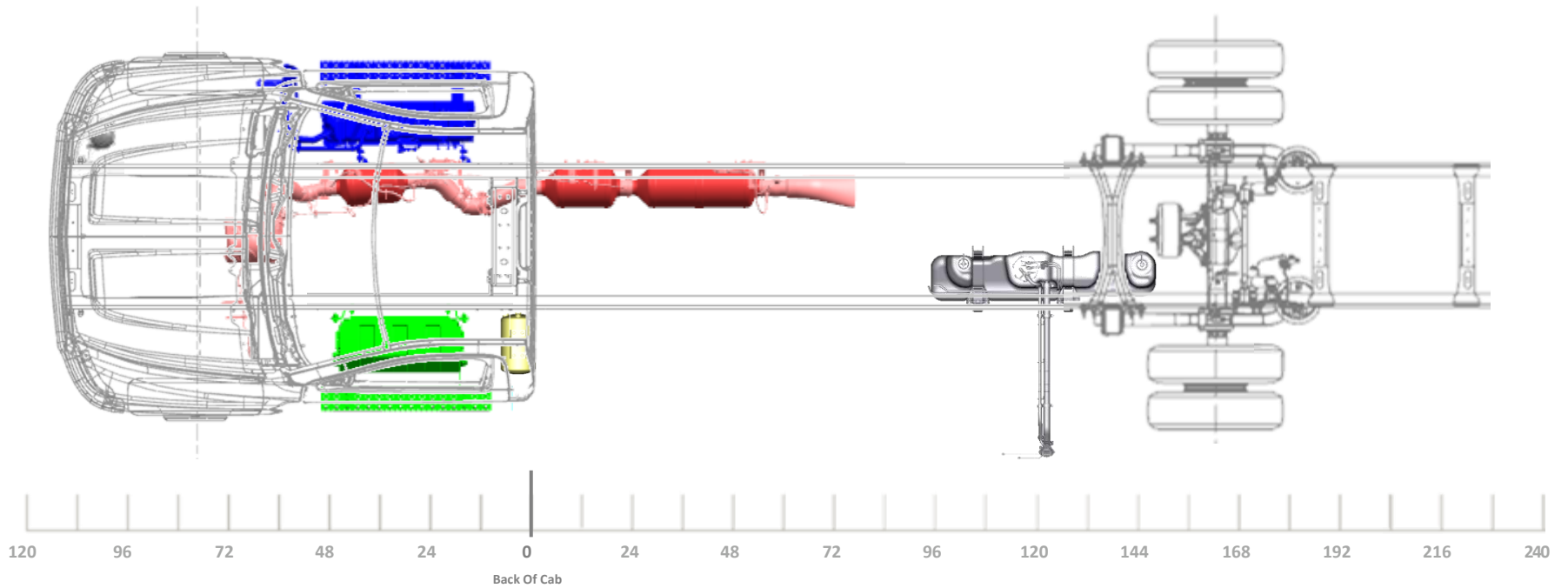

LAST REVISION: 9/25/2023

Model/Feature Information

Model:		C56403 K56403
Cab:		REGULAR CAB
Aftertreatment:		HORIZONTAL
Fuel Tank:	RPO NVK	25 GAL, CA MTD
Battery Box:	RPO 7Y9	TEMP MTD, 3 BATT
Air Tanks:		(1) OUTSIDE LEFT
DEF Tank:		6.75 GAL
Engine:		6.6L GM DURAMAX

General Configuration Information

4X2 OR 4X4 TRUCK CONFIGURATION
 VARI-RATE REAR SUSPENSION

STRAIGHT TAILPIPE (RPO N12)

OPTIONAL AIR DRYER FWD OUTSIDE
 RT (RPO KUT/JPY)

Minimum Wheelbase

243" WB (162" CA)
 83"AF

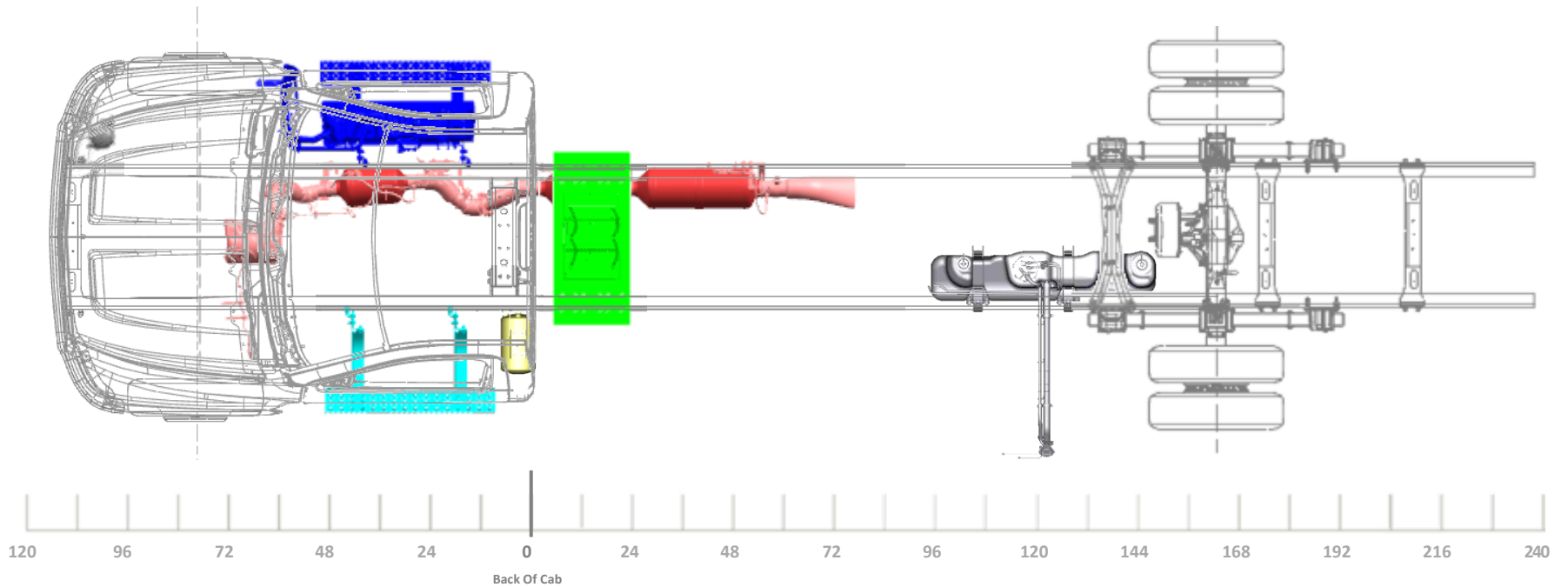

LAST REVISION: 9/25/2023

Model/Feature Information

Model:		C56403 K56403
Cab:		REGULAR CAB
Aftertreatment:		HORIZONTAL
Fuel Tank:	RPO NVK	25 GAL, CA MTD
Battery Box:	RPO 7Y9	TEMP MTD, 3 BATT
Air Tanks:		(1) OUTSIDE LEFT
DEF Tank:		6.75 GAL
Engine:		6.6L GM DURAMAX

General Configuration Information

4X2 TRUCK CONFIGURATION
REAR AIR SUSPENSION
STRAIGHT TAILPIPE (RPO N12)
OPTIONAL AIR DRYER FWD OUTSIDE RT (RPO KUT/JPY)

Minimum Wheelbase

243" WB (162" CA)
83"AF

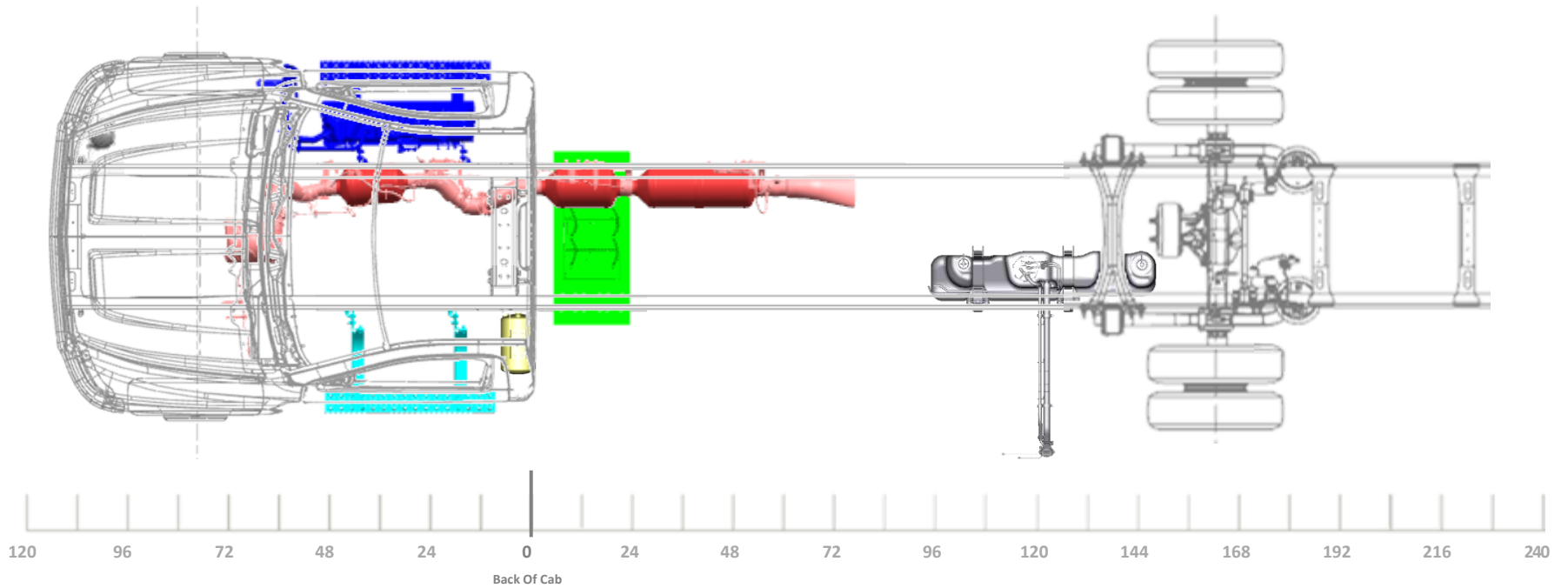

LAST REVISION: 9/25/2023

Model/Feature Information

Model:		C56403 K56403
Cab:		REGULAR CAB
Aftertreatment:		HORIZONTAL
Fuel Tank:	RPO NVK	25 GAL, CA MTD
Battery Box:	RPO 7Y7/7Y8	28" STEEL, 2 BATTERIES
Air Tanks:		(1) OUTSIDE LEFT
DEF Tank:		6.75 GAL
Engine:		6.6L GM DURAMAX

General Configuration Information

4X2 OR 4X4 TRUCK CONFIGURATION
VARI-RATE REAR SUSPENSION

SIDE EXIT TAILPIPE AHEAD OF REAR
WHEELS, RT SIDE (RPO NPK)

OPTIONAL AIR DRYER FWD OUTSIDE
RT (RPO KUT/JPY)

Minimum Wheelbase

243" WB (162" CA)
83"AF

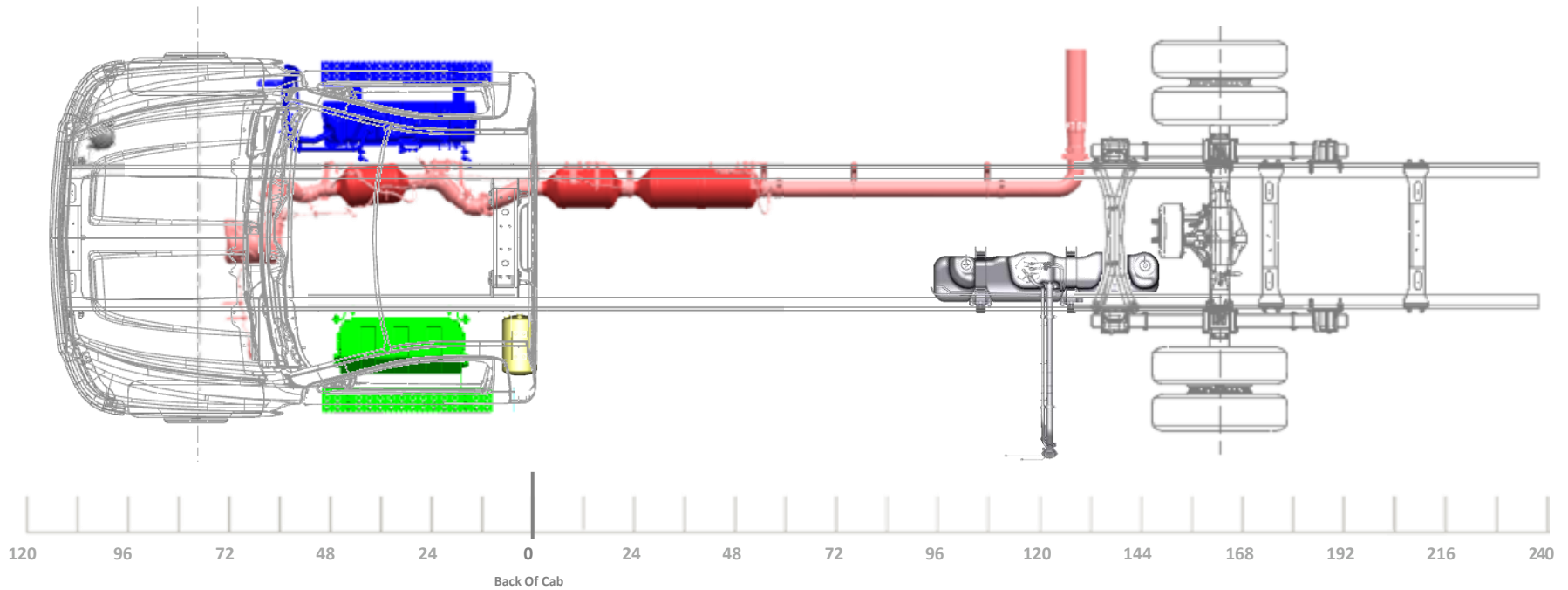

LAST REVISION: 9/25/2023

Model/Feature Information

Model:		C56403 K56403
Cab:		REGULAR CAB
Aftertreatment:		HORIZONTAL
Fuel Tank:	RPO NVK	25 GAL, CA MTD
Battery Box:	RPO 7Y7/7Y8	28" STEEL, 2 BATTERIES
Air Tanks:		(1) OUTSIDE LEFT
DEF Tank:		6.75 GAL
Engine:		6.6L GM DURAMAX

General Configuration Information

4X2 TRUCK CONFIGURATION
REAR AIR SUSPENSION
SIDE EXIT TAILPIPE AHEAD OF REAR WHEELS, RT SIDE (RPO NPK)
OPTIONAL AIR DRYER FWD OUTSIDE RT (RPO KUT/JPY)

Minimum Wheelbase

243" WB (162" CA)
83"AF

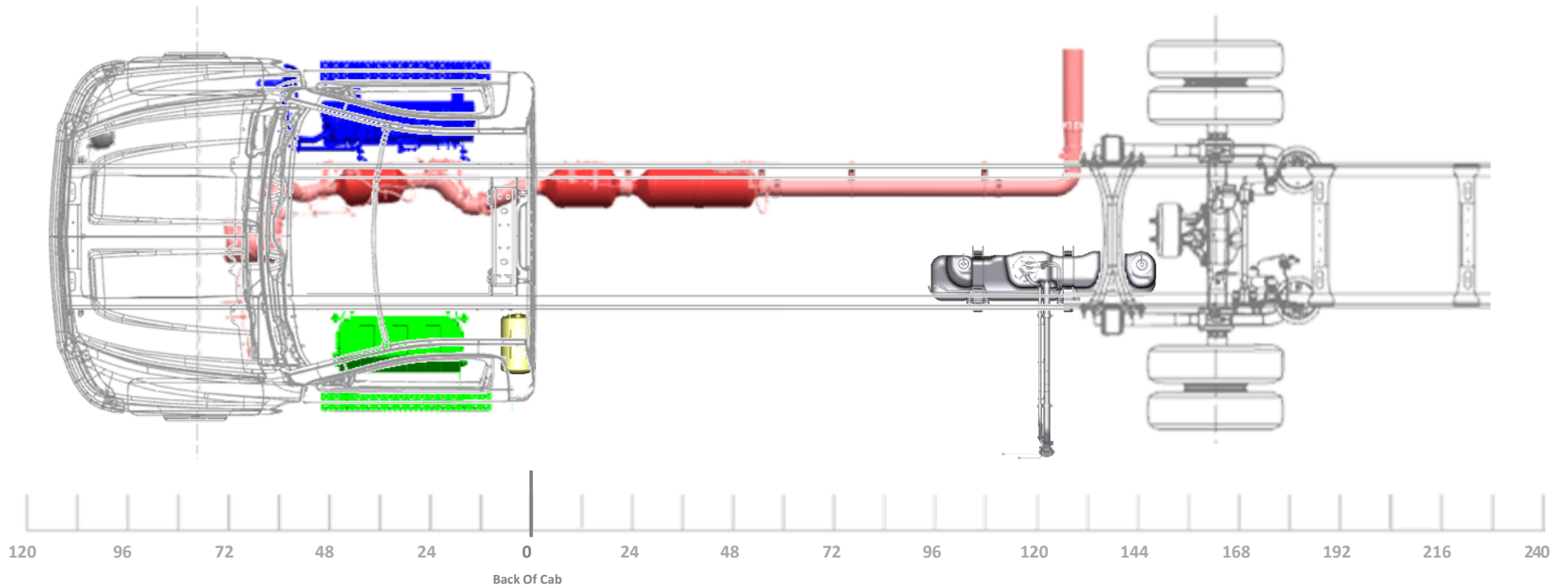

LAST REVISION: 9/25/2023

Model/Feature Information

Model:		C56403 K56403
Cab:		REGULAR CAB
Aftertreatment:		HORIZONTAL
Fuel Tank:	RPO NVK	25 GAL, CA MTD
Battery Box:	RPO 7Y9	TEMP MTD, 3 BATT
Air Tanks:		(1) OUTSIDE LEFT
DEF Tank:		6.75 GAL
Engine:		6.6L GM DURAMAX

General Configuration Information

4X2 OR 4X4 TRUCK CONFIGURATION
 VARI-RATE REAR SUSPENSION

SIDE EXIT TAILPIPE AHEAD OF REAR
 WHEELS, RT SIDE (RPO NPK)

OPTIONAL AIR DRYER FWD OUTSIDE
 RT (RPO KUT/JPY)

Minimum Wheelbase

243" WB (162" CA)
 83"AF

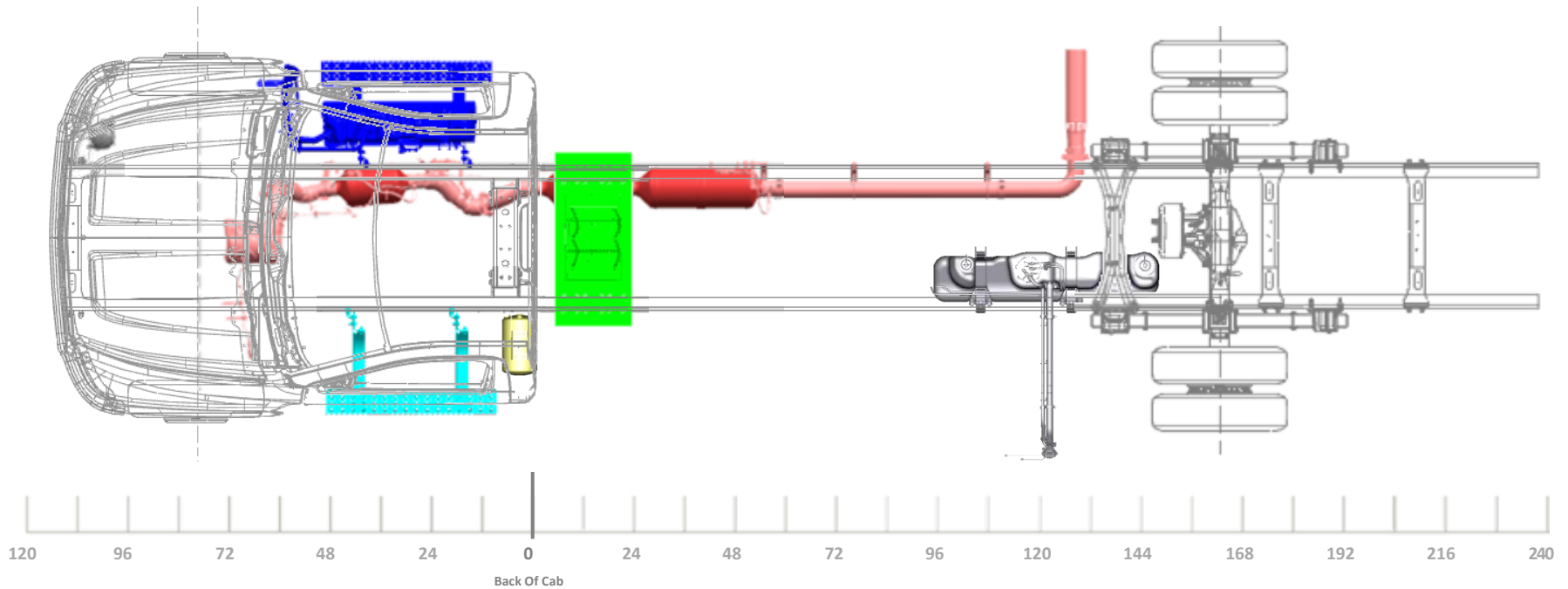

LAST REVISION: 9/25/2023

Model/Feature Information

Model:		C56403 K56403
Cab:		REGULAR CAB
Aftertreatment:		HORIZONTAL
Fuel Tank:	RPO NVK	25 GAL, CA MTD
Battery Box:	RPO 7Y9	TEMP MTD, 3 BATT
Air Tanks:		(1) OUTSIDE LEFT
DEF Tank:		6.75 GAL
Engine:		6.6L GM DURAMAX

General Configuration Information

4X2 TRUCK CONFIGURATION
 REAR AIR SUSPENSION
 SIDE EXIT TAILPIPE AHEAD OF REAR WHEELS, RT SIDE (RPO NPK)
 OPTIONAL AIR DRYER FWD OUTSIDE RT (RPO KUT/JPY)

Minimum Wheelbase

243" WB (162" CA)
 83"AF

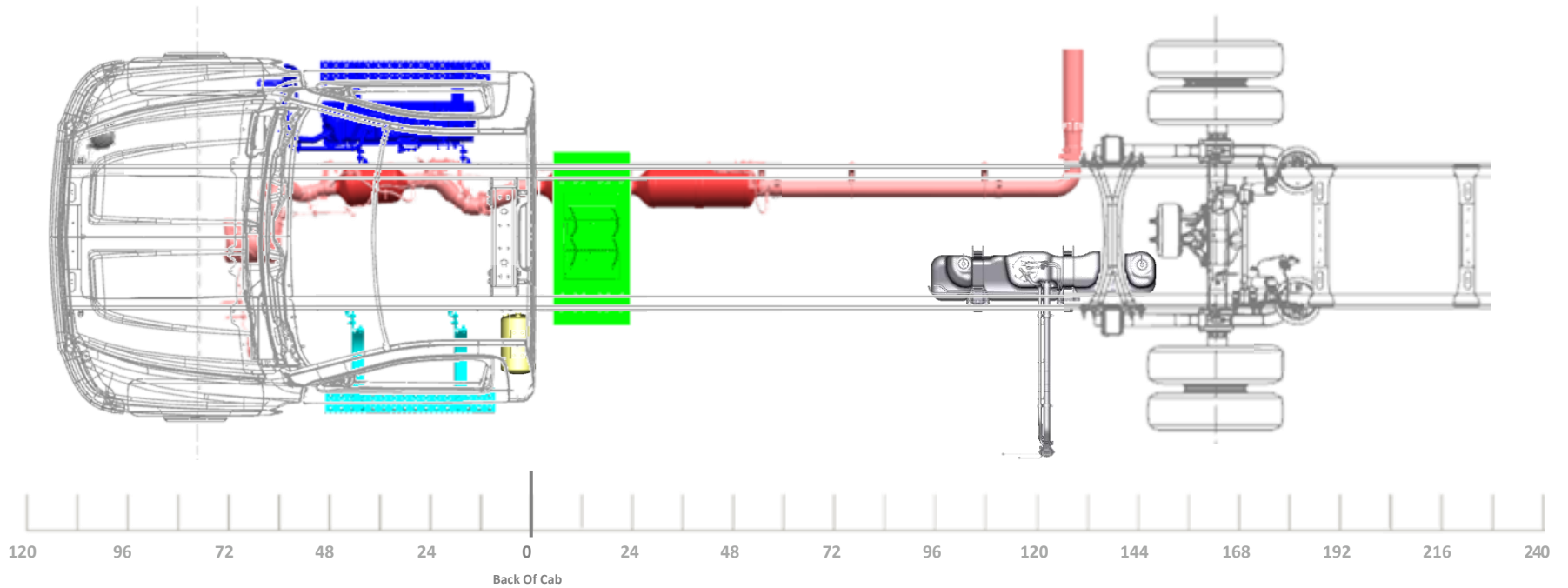

LAST REVISION: 9/25/2023

Model/Feature Information

Model:		C56403 K56403
Cab:		REGULAR CAB
Aftertreatment:		HORIZONTAL
Fuel Tank:	RPO NSQ	DUAL 25G CA, 40G AF
Battery Box:	RPO 7Y7/7Y8	28" STEEL, 2 BATTERIES
Air Tanks:		(1) OUTSIDE LEFT
DEF Tank:		6.75 GAL
Engine:		6.6L GM DURAMAX

General Configuration Information

4X2 OR 4X4 TRUCK CONFIGURATION
 VARI-RATE REAR SUSPENSION

STRAIGHT TAILPIPE (RPO N12)

OPTIONAL AIR DRYER FWD OUTSIDE
 RT (RPO KUT/JPY)

Minimum Wheelbase

243" WB (162" CA)
 83" AF

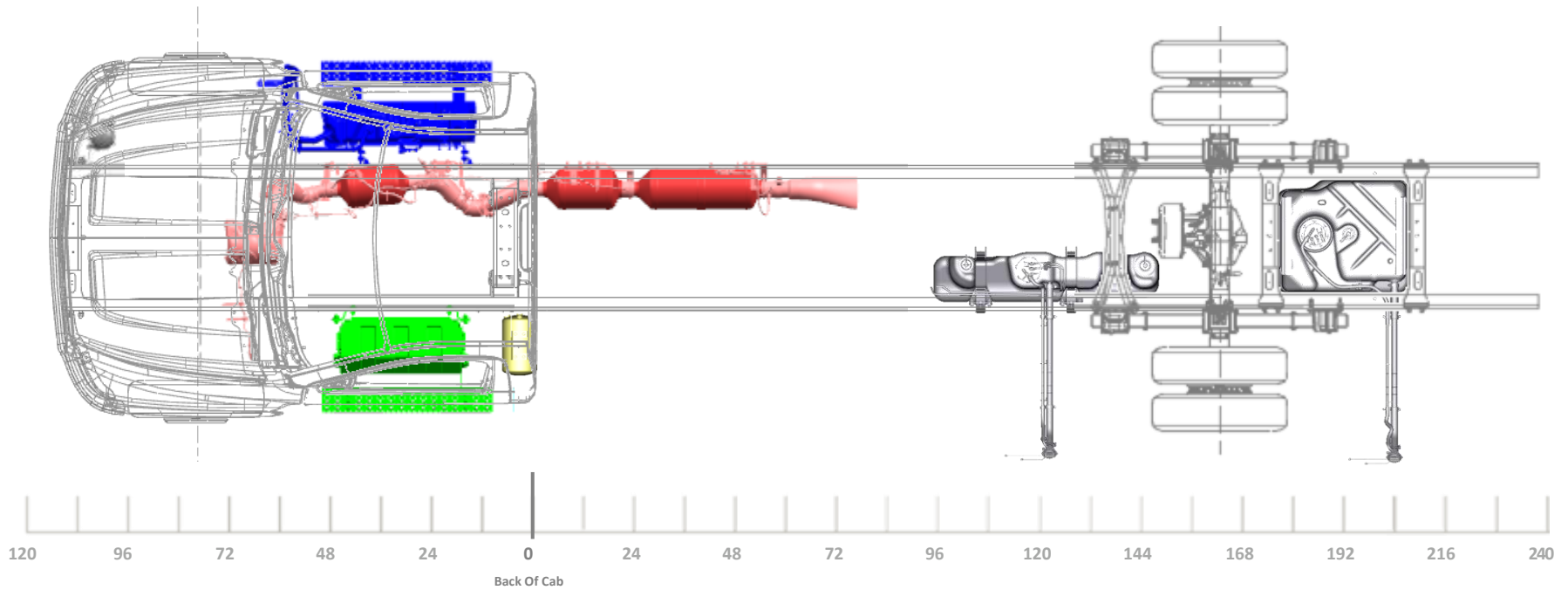

LAST REVISION: 9/25/2023

Model/Feature Information

Model:		C56403 K56403
Cab:		REGULAR CAB
Aftertreatment:		HORIZONTAL
Fuel Tank:	RPO NSQ	DUAL 25G CA, 40G AF
Battery Box:	RPO 7Y7/7Y8	28" STEEL, 2 BATTERIES
Air Tanks:		(1) OUTSIDE LEFT
DEF Tank:		6.75 GAL
Engine:		6.6L GM DURAMAX

General Configuration Information

4X2 TRUCK CONFIGURATION
REAR AIR SUSPENSION
STRAIGHT TAILPIPE (RPO N12)
OPTIONAL AIR DRYER FWD OUTSIDE RT (RPO KUT/JPY)

Minimum Wheelbase

243" WB (162" CA)
83"AF

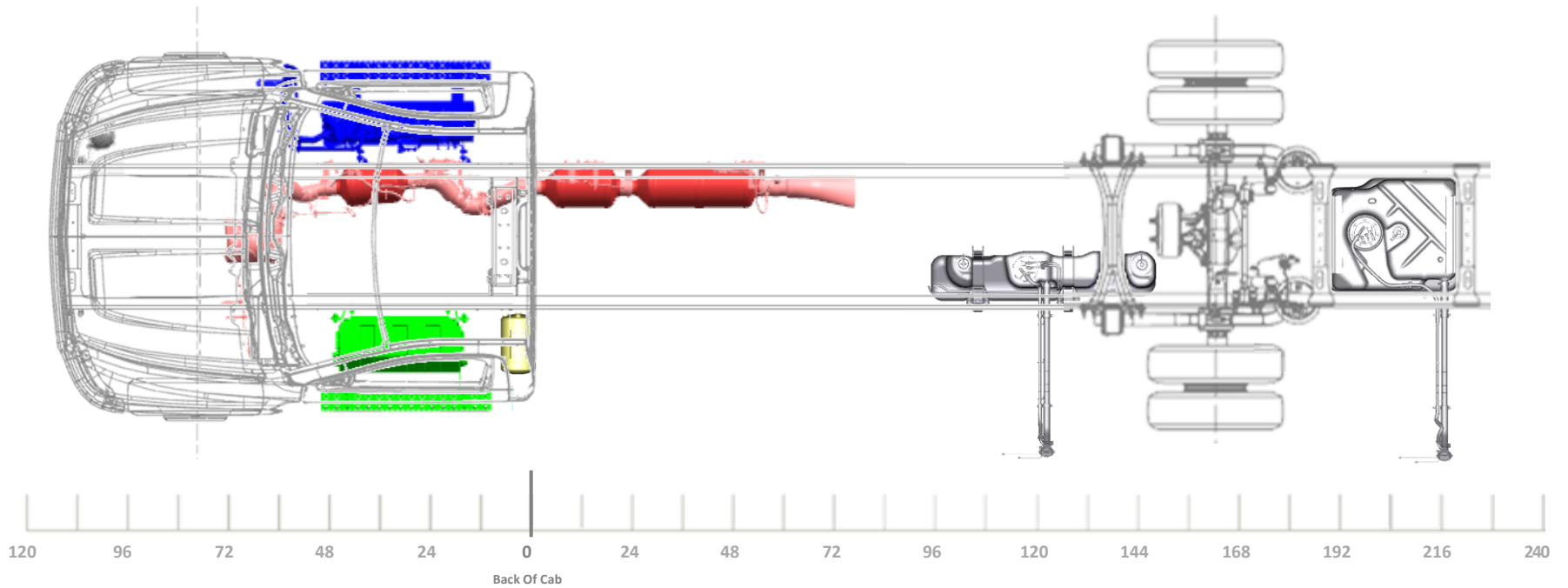

LAST REVISION: 9/25/2023

Model/Feature Information

Model:		C56403 K56403
Cab:		REGULAR CAB
Aftertreatment:		HORIZONTAL
Fuel Tank:	RPO NSQ	DUAL 25G CA, 40G AF
Battery Box:	RPO 7Y9	TEMP MTD, 3 BATT
Air Tanks:		(1) OUTSIDE LEFT
DEF Tank:		6.75 GAL
Engine:		6.6L GM DURAMAX

General Configuration Information

4X2 OR 4X4 TRUCK CONFIGURATION
 VARI-RATE REAR SUSPENSION

STRAIGHT TAILPIPE (RPO N12)

OPTIONAL AIR DRYER FWD OUTSIDE
 RT (RPO KUT/JPY)

Minimum Wheelbase

243" WB (162" CA)
 83"AF

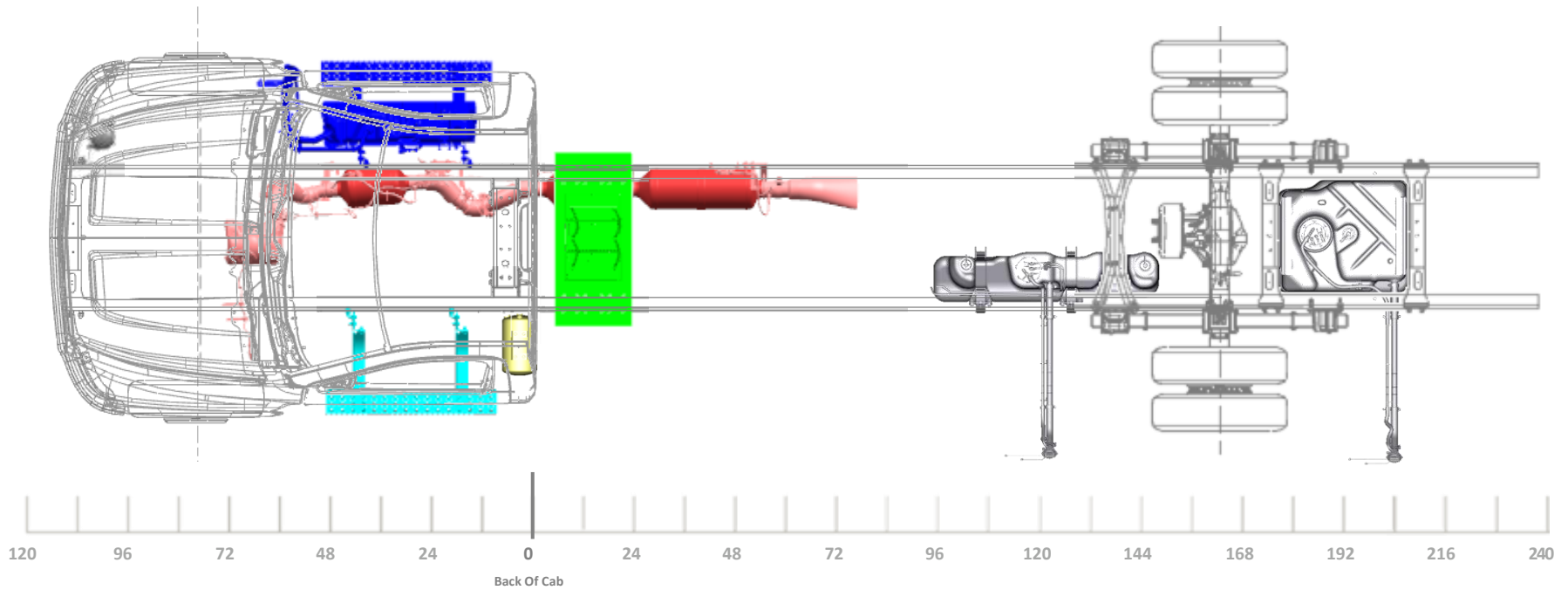

LAST REVISION: 9/25/2023

Model/Feature Information

Model:		C56403 K56403
Cab:		REGULAR CAB
Aftertreatment:		HORIZONTAL
Fuel Tank:	RPO NSQ	DUAL 25G CA, 40G AF
Battery Box:	RPO 7Y9	TEMP MTD, 3 BATT
Air Tanks:		(1) OUTSIDE LEFT
DEF Tank:		6.75 GAL
Engine:		6.6L GM DURAMAX

General Configuration Information

4X2 TRUCK CONFIGURATION
REAR AIR SUSPENSION
STRAIGHT TAILPIPE (RPO N12)
OPTIONAL AIR DRYER FWD OUTSIDE RT (RPO KUT/JPY)

Minimum Wheelbase

243" WB (162" CA)
83"AF

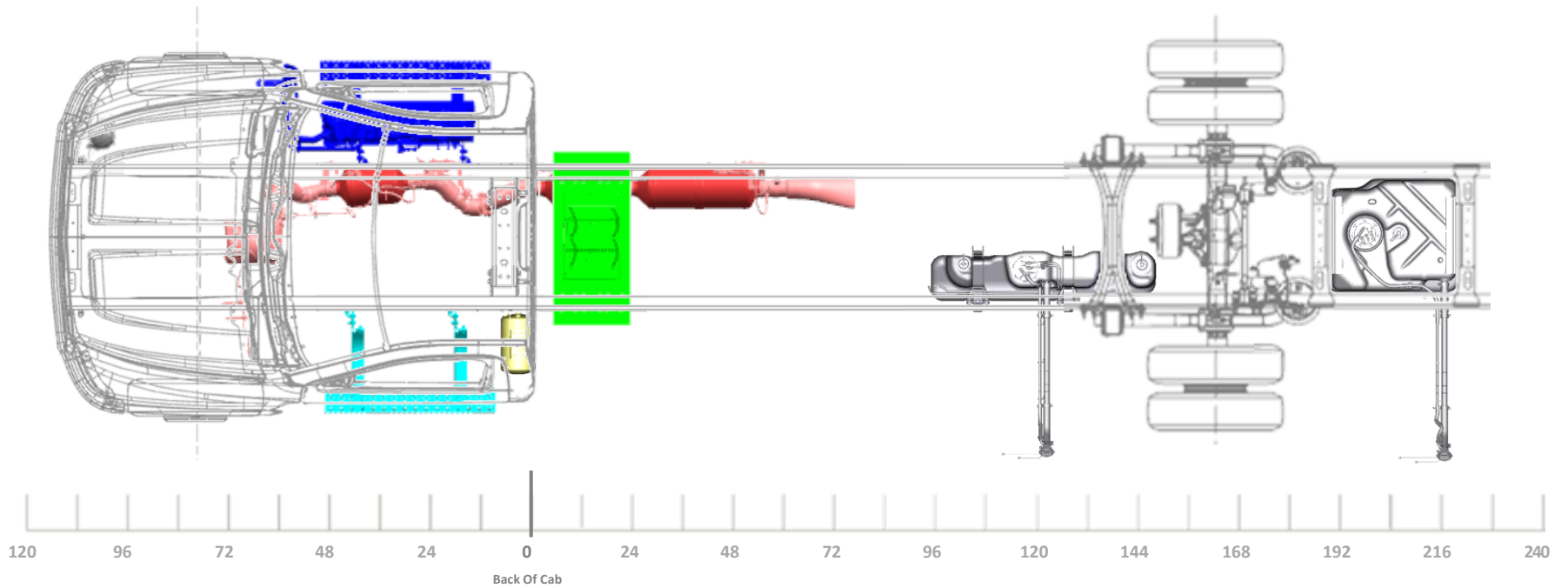

LAST REVISION: 9/25/2023

Model/Feature Information

Model:		C56403 K56403
Cab:		REGULAR CAB
Aftertreatment:		HORIZONTAL
Fuel Tank:	RPO NSQ	DUAL 25G CA, 40G AF
Battery Box:	RPO 7Y7/7Y8	28" STEEL, 2 BATTERIES
Air Tanks:		(1) OUTSIDE LEFT
DEF Tank:		6.75 GAL
Engine:		6.6L GM DURAMAX

General Configuration Information

4X2 OR 4X4 TRUCK CONFIGURATION
 VARI-RATE REAR SUSPENSION

SIDE EXIT TAILPIPE AHEAD OF REAR
 WHEELS, RT SIDE (RPO NPK)

OPTIONAL AIR DRYER FWD OUTSIDE
 RT (RPO KUT/JPY)

Minimum Wheelbase

243" WB (162" CA)
 83"AF

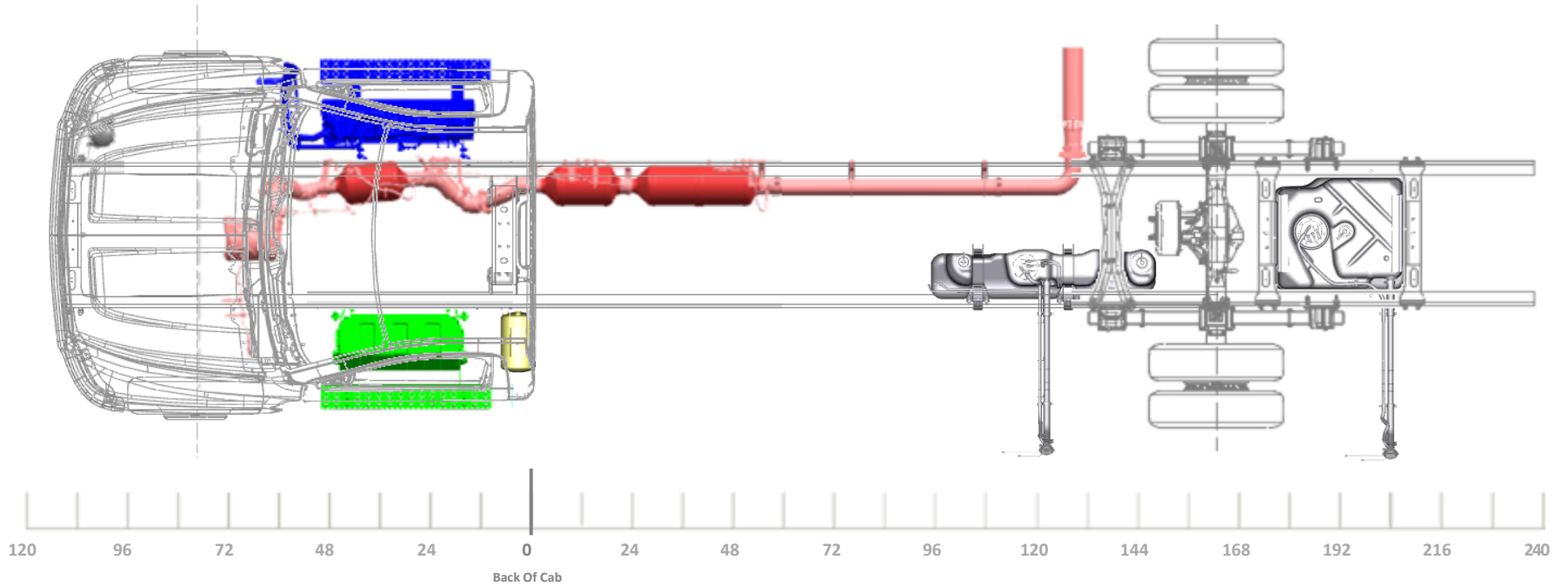

LAST REVISION: 9/25/2023

Model/Feature Information

Model:		C56403 K56403
Cab:		REGULAR CAB
Aftertreatment:		HORIZONTAL
Fuel Tank:	RPO NSQ	DUAL 25G CA, 40G AF
Battery Box:	RPO 7Y7/7Y8	28" STEEL, 2 BATTERIES
Air Tanks:		(1) OUTSIDE LEFT
DEF Tank:		6.75 GAL
Engine:		6.6L GM DURAMAX

General Configuration Information

4X2 TRUCK CONFIGURATION
REAR AIR SUSPENSION
SIDE EXIT TAILPIPE AHEAD OF REAR WHEELS, RT SIDE (RPO NPK)
OPTIONAL AIR DRYER FWD OUTSIDE RT (RPO KUT/JPY)

Minimum Wheelbase

243" WB (162" CA)
83"AF

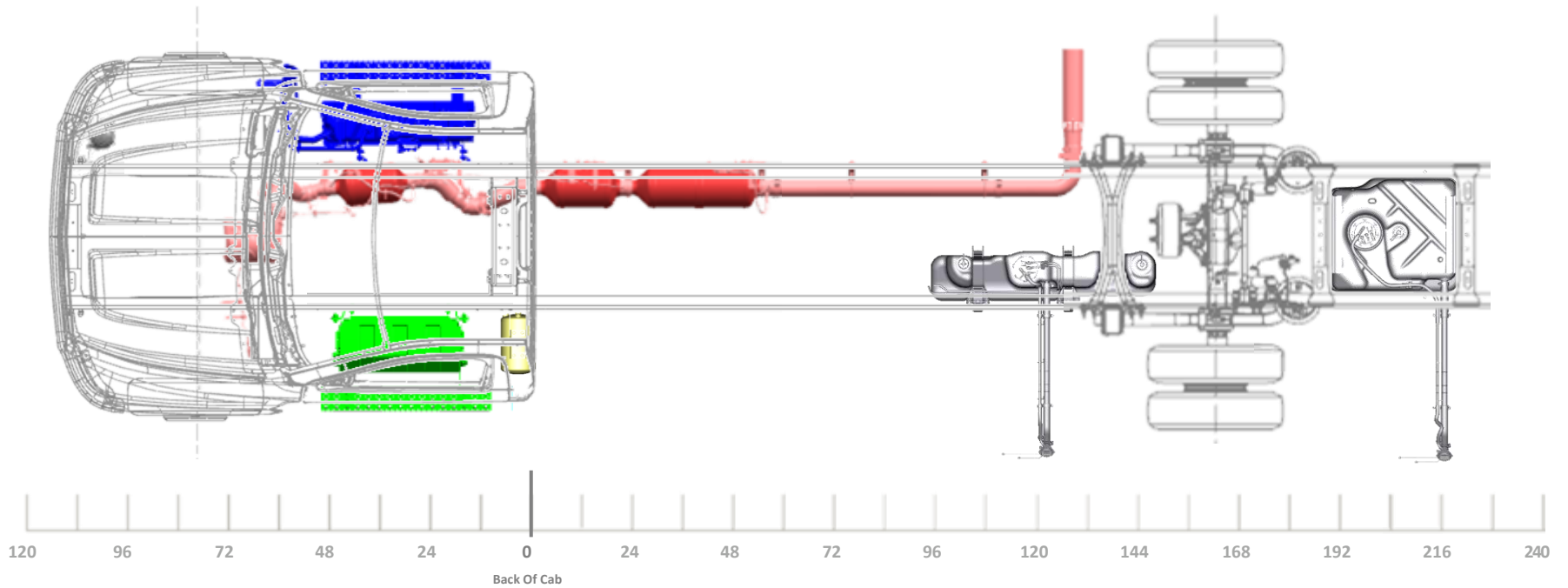

LAST REVISION: 9/25/2023

Model/Feature Information

Model:		C56403 K56403
Cab:		REGULAR CAB
Aftertreatment:		HORIZONTAL
Fuel Tank:	RPO NSQ	DUAL 25G CA, 40G AF
Battery Box:	RPO 7Y9	TEMP MTD, 3 BATT
Air Tanks:		(1) OUTSIDE LEFT
DEF Tank:		6.75 GAL
Engine:		6.6L GM DURAMAX

General Configuration Information

4X2 OR 4X4 TRUCK CONFIGURATION
 VARI-RATE REAR SUSPENSION

SIDE EXIT TAILPIPE AHEAD OF REAR
 WHEELS, RT SIDE (RPO NPK)

OPTIONAL AIR DRYER FWD OUTSIDE
 RT (RPO KUT/JPY)

Minimum Wheelbase

243" WB (162" CA)
 83"AF

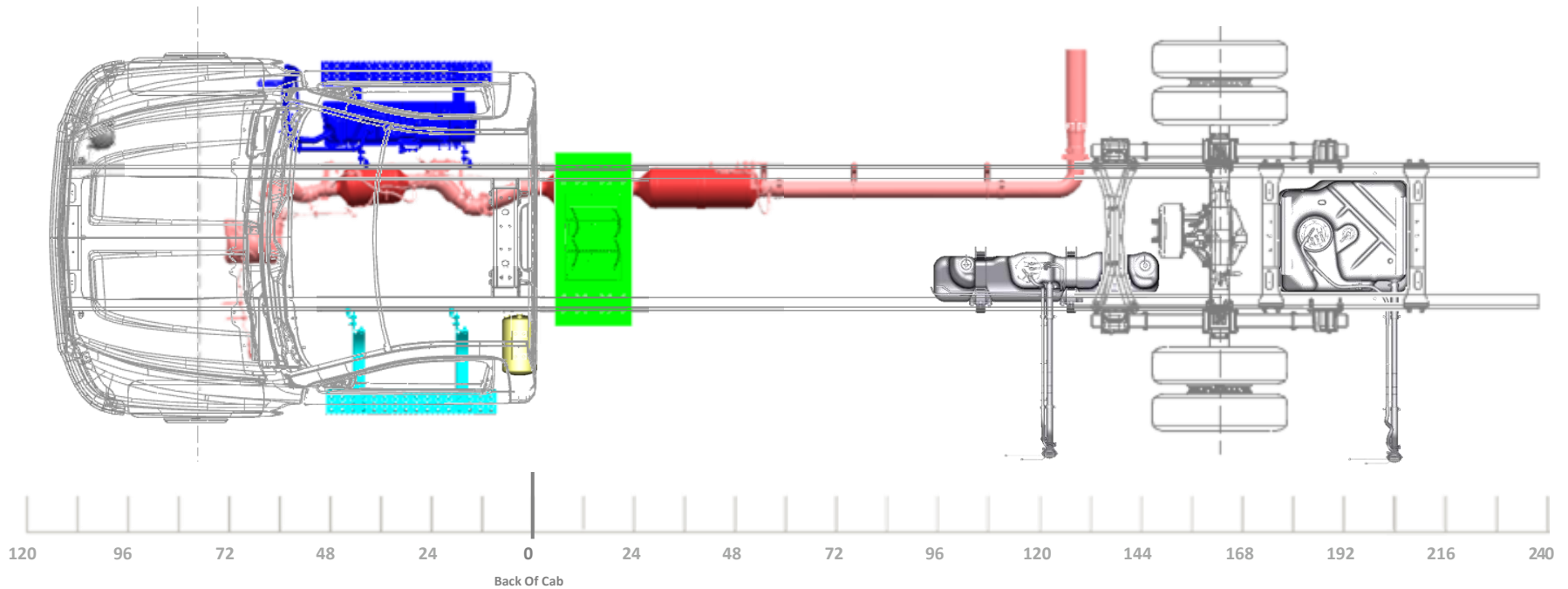

LAST REVISION: 9/25/2023

Model/Feature Information

Model:		C56403 K56403
Cab:		REGULAR CAB
Aftertreatment:		HORIZONTAL
Fuel Tank:	RPO NSQ	DUAL 25G CA, 40G AF
Battery Box:	RPO 7Y9	TEMP MTD, 3 BATT
Air Tanks:		(1) OUTSIDE LEFT
DEF Tank:		6.75 GAL
Engine:		6.6L GM DURAMAX

General Configuration Information

4X2 TRUCK CONFIGURATION
REAR AIR SUSPENSION
SIDE EXIT TAILPIPE AHEAD OF REAR WHEELS, RT SIDE (RPO NPK)
OPTIONAL AIR DRYER FWD OUTSIDE RT (RPO KUT/JPY)

Minimum Wheelbase

243" WB (162" CA)
83"AF

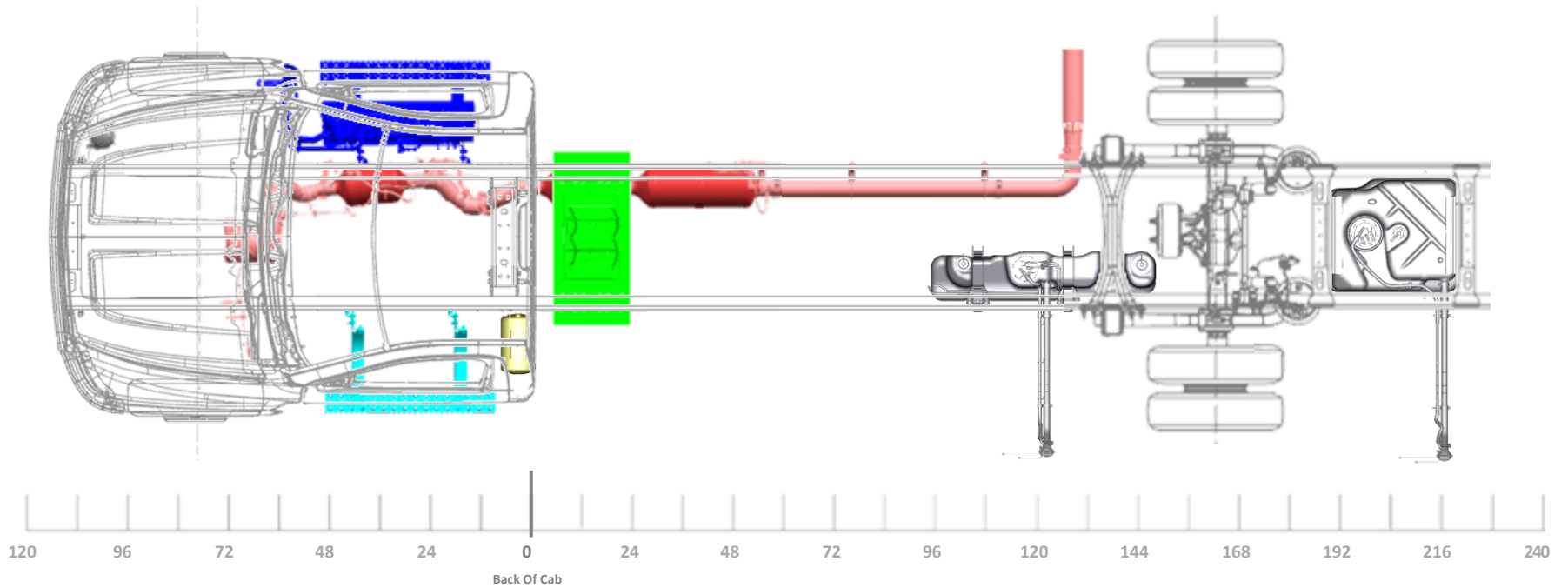

LAST REVISION: 9/25/2023