



86595970

DOCUMENT FOR INCOMPLETE VEHICLE APPLICABLE TO 2026 MODEL YEAR SILVERADO / SIERRA LIGHT & HEAVY DUTY FULL-SIZE TRUCKS & TAHOE SUV

General Motors, Renaissance Center
P.O. Box 300
Detroit, Michigan 48265-3000
www.gm.com

DO NOT REMOVE

THIS DOCUMENT MUST REMAIN WITH THIS VEHICLE
UNTIL IT IS CERTIFIED AS A COMPLETED VEHICLE

PLACE LABEL HERE

The Label affixed here includes the following information:

- the name of the incomplete vehicle manufacturer;
- the month and year the incomplete vehicle manufacturer performed its last manufacturing operation on the incomplete vehicle;
- the vehicle identification number (VIN);
- the Gross Vehicle Weight Rating (GVWR) expressed in kg (lb), intended for the vehicle when it is a completed vehicle;
- the Gross Axle Weight Rating (GAWR) expressed in kg (lb), intended for each axle of the vehicle when it is a completed vehicle, listed in order from front to rear
- Tire size, rim size, cold tire pressure.

This document is furnished as required by the Canada Motor Vehicle Safety Regulations and United States (U.S.) Federal Motor Vehicle Safety Regulations (FMVSR) to aid intermediate and final stage manufacturers in their determination of conformity of the completed vehicle with applicable Canada Motor Vehicle Safety Standards (CMVSS) and U.S. Federal Motor Vehicle Safety Standards (FMVSS). Also included are instructions which must be followed in order to assure that Environmental Protection Agency (EPA) and California Air Resources Board (CARB) emission certification requirements and U.S. National Highway Traffic Safety Administration (NHTSA) Fuel Economy Regulations and Environmental Protection Agency (EPA) Greenhouse Gas Regulations are met.

This document is not a substitute for knowledge and understanding of the requirements of the Canada Motor Vehicle Safety Act, Federal Motor Vehicle Safety Regulations (FMVSR), or applicable Canada Motor Vehicle Safety Standards (CMVSS) and Federal Motor Vehicle Safety Standards (FMVSS). Intermediate and final stage manufacturers should be familiar with the Regulations and Standards referred to above to be aware of their specific responsibilities as they relate to the final destination and sale of each incomplete vehicle.

Any intermediate or final stage manufacturer making material alterations to this incomplete vehicle during the process of manufacturing the complete vehicle should be constantly vigilant to recognize all the effects, either direct or indirect, on other components, assemblies or systems caused by any alteration. No alteration should be made to the incomplete vehicle that either directly or indirectly results in any component, assembly or system being in nonconformance with any

applicable Canada Motor Vehicle Safety Standard or Federal Motor Vehicle Safety Standard or Emission Regulation or Fuel Economy/Greenhouse Gas Regulation.

The statements contained in this Incomplete Vehicle Document are accurate as of the date of manufacture of the Incomplete Vehicle and can be relied on by any intermediate and/or final stage manufacturer as a basis for certification.

INTRODUCTION

This document contains information relative to conformance of this incomplete vehicle with the following:

- Part I - **FEDERAL MOTOR VEHICLE SAFETY STANDARDS AND CANADA MOTOR VEHICLE SAFETY STANDARDS**
- Part II - **U.S. ENVIRONMENTAL PROTECTION AGENCY, STATE OF CALIFORNIA, AND CANADIAN EMISSION REQUIREMENTS AND NHTSA FUEL ECONOMY REQUIREMENTS**

PART I

For C/K Chassis Cab, refer to Part I, Chart A that follows. This section contains a list of Canada Motor Vehicle Safety Standards (CMVSS), and Federal Motor Vehicle Safety Standards (FMVSS), followed by a section entitled "Statements Regarding Canada Motor Vehicle Safety Standards (CMVSS), and Federal Motor Vehicle Safety Standards (FMVSS)". In the latter section, an appropriate statement of applicability is made for each standard, and by vehicle type, as it relates to the incomplete vehicle.

Basic Type CK Chassis Cab Incomplete Vehicle **TYPE: Truck or (Ambulance--Canada only)**



Normally complete type C/K Pickup or Utility Vehicles that follow, along with the basic type incomplete C/K Chassis Cab above that are built with specific Regular Production Option (RPO) or Special Equipment Option (SEO), may require additional statements of applicability. If required, the additional statements will be found under each affected CMVSS and/or FMVSS Standard.

Normally Complete Type CK Vehicle Types

Pick-up **TYPE: Truck**



Utility **TYPE: Multipurpose Vehicle**



The identifiers TYPE 1, TYPE 2 or TYPE 3 prefix the statements (of applicability) regarding Canada Motor Vehicle Safety Standards (CMVSS), and Federal Motor Vehicle Safety Standards (FMVSS). "Examples" of these statements follow:

TYPE 1 A statement that the vehicle when completed will conform to the standard if no alterations are made in identified components of the incomplete vehicle. **EXAMPLE:** This vehicle when complete will conform to CMVSS 104 and FMVSS No. 104, Windshield Wiping and Washing Systems, if no alterations are made in the windshield wiper components.

TYPE 2 A statement of specific conditions of final manufacture under which the manufacturer specifies that the completed vehicle will conform to the standard. **EXAMPLE:** This vehicle when completed will conform to CMVSS 121 and FMVSS 121, Air Brake Systems, if it does not exceed any of the gross axle weight ratings, if the center of gravity at GVWR is not higher than ## feet above the ground, and if no alterations are made to any brake system component.

TYPE 3 A statement that conformity with the standard cannot be determined based upon the components supplied on the incomplete vehicle, and that the incomplete vehicle manufacturer makes no representation to conformity with the standard.

In accordance with the requirements of Canada Motor Vehicle Safety Regulations, and Federal Motor Vehicle Safety Regulations Part 568.4, the following information is included on the label affixed to the front cover of this document:

- the name of the incomplete vehicle manufacturer;
- the month and year the incomplete vehicle manufacturer performed its last manufacturing operation on the incomplete vehicle;
- the vehicle identification number (VIN);
- the Gross Vehicle Weight Rating (GVWR) expressed in kg (lb.), intended for the vehicle when it is a completed vehicle;
- the Gross Axle Weight Rating (GAWR) expressed in kg (lb.), intended for each axle of the vehicle when it is a completed vehicle, listed in order from front to rear.

In addition, the final stage manufacturer is responsible under Canada Motor Vehicle Safety Regulations, and Federal Motor Vehicle Safety Regulations and Part 567.5, to place the GVWR and the GAWR of each axle, on the Final Vehicle Certification Label. Required on label is the "Gross Vehicle Weight Rating" or "GVWR" followed by the appropriate value in kilograms and (pounds), which shall not be less than the sum of the unloaded vehicle weight, rated cargo load, and 68 kg (150 lb.) times the number of the vehicle's designated seating positions, if known. However, for school buses the minimum occupant weight allowance shall be 54.4 kg (120 lb.) per passenger and 68 kg (150 lb.) for the driver.

Unloaded Vehicle Weight means the weight of a vehicle with maximum capacity of all fluids necessary for operation of the vehicle, but without cargo or occupants or accessories that are ordinarily removed from the vehicle when they are not in use.

During the completion of this vehicle, GVWR and GAWR may be affected in various ways, including but not limited to the following:

- The installation of a body or equipment that exceeds the rated capacities of the Incomplete Vehicle.
- The addition of designated seating positions that exceed the rated capacities of the Incomplete Vehicle.
- Alterations or substitution of any components such as axles, springs, tires, wheels, frames, steering and brake systems that may affect the rated capacities of the Incomplete Vehicle.

On page 2 before each vehicle illustration and after the word TYPE, is a list of types of vehicles into which the incomplete vehicle is designed to be manufactured.

If supplemental technical information is required to support this document, go to the GM Upfitter Integration website located at www.gmupfitter.com

PART I – CHART A

LIST OF CANADA MOTOR VEHICLE SAFETY STANDARDS (CMVSS) AND
FEDERAL MOTOR VEHICLE SAFETY STANDARDS (FMVSS), APPLICABLE TO THE C/K
CHASSIS CAB, PICK-UP, OR UTILITY

SEE STATEMENTS REGARDING CMVSS AND FMVSS ON PAGES THAT FOLLOW

CMVSS NO.	FMVSS NO.	TITLE	CHASSIS CAB	PICK-UP	UTILITY
1106	-	Exterior noise	1	1	1
ICES-002	-	Canada interference causing equipment standard	1	1	1
101	101	Controls and displays	1	1	1
102	102	Transmission shift position sequence, starter interlock, and transmission braking effect	2,3	2,3	2,3
103	103	Windshield defrosting and defogging systems	1	1	1
104	104	Windshield wiping and washing systems	1	1	1
105	105	Hydraulic and electric brake systems	2	2	2
106	106	Brake hoses, hydraulic, air and vacuum	1	1	1
108	-	Daytime running lamps	1	1	1
108	108	Lamps, reflective devices and associated equipment	2,3	1	1
110	110	Tire selection and rims for motor vehicles with a GVWR of 4536 kg (10,000 lb.) or less	2	2	2
111	111	Rearview visibility	1,2,3	1,3	1,3
113	113	Hood latch system	1	1	1
114	114	Theft protection and rollaway prevention	1	1	1
115	-	Vehicle identification number	1	1	1
116	116	Motor vehicle brake fluids	1	1	1
118	118	Power operated window, partition and roof panel systems	1	1	1
120	120	Tire selection and rims for motor vehicles with a GVWR more than 4536 kg (10,000 lbs)	2	2	2
124	124	Accelerator control systems	1,3	1,3	1,3
-	125	Warning devices designed to be carried in motor vehicles	1	1	1
126	126	Electronic stability control systems	2	2	2
-	127	Automatic emergency braking systems for light vehicles	3	3	3
135	135	Light vehicle brake systems	2	2	2
-	138	Tire pressure monitoring systems	2	2	2
201	201	Occupant protection in interior impact	1,3	1,3	1,3
202	202A	Head restraints	1	1	1,3
203	203	Impact protection for the driver from the steering control system	1,3	1,3	1,3
204	204	Steering control rearward displacement	2,3	2,3	2,3
205	205	Glazing materials	1	1	1
206	206	Door locks and retention components	1,3	1,3	1,3
207	207	Seating systems	1,3	1,3	1,3

CMVSS NO.	FMVSS NO.	TITLE	CHASSIS CAB	PICK-UP	UTILITY
208	208	Occupant crash protection	1,2,3	1,2,3	1,2,3
209	209	Seat belt assemblies	1,3	1,3	1,3
210	210	Seat belt assembly anchorages	1,3	1,3	1,3
210.1	-	Tether anchorages for restraint systems	1,3	1,3	1,3
210.2	-	Lower universal anchorage systems for restraint systems and booster cushions	1,3	1,3	1,3
212	212	Windshield mounting	2	2	2
213.4	213	Built-in child restraint systems and built-in booster cushions	3	3	3
214	214	Side impact protection	2	2	2
216	216a	Roof crush Resistance	2	2	2
219	219	Windshield zone intrusion	2	2	2
220	220	School bus rollover protection	3	3	3
-	225	Child restraint anchorage systems	1,3	1,3	1,3
226	226	Ejection Mitigation	1,3	1,3	1,3
301	301	Fuel system integrity	2	2	2
301.1	-	LPG fuel system integrity	3	3	3
302	302	Flammability of interior materials	1,3	1,3	1,3
301.2	303	CNG fuel system integrity	3	3	3
-	304	Compressed natural gas fuel containers	3	3	3
-	403	Platform lift systems	3	3	3
-	404	Platform lift installations in motor vehicles	3	3	3

- TYPE 1, 2 or 3 numbers to the right hand side of the table above designate the appropriate paragraph in the CMVSS or FMVSS standards that follow.

Statements Regarding Canada Motor Vehicle Safety Standards (CMVSS), and Federal Motor Vehicle Safety Standards (FMVSS)

CMVSS 1106 – EXTERIOR NOISE

Applies to all types of Incomplete Vehicles Contained in this Document

TYPE 1 The following statement is applicable to all types of incomplete vehicles contained in this document (unless otherwise noted on the cover).

- A. This incomplete vehicle, when completed, will conform to the above standard providing no alterations are made which affect the function, physical, chemical, or mechanical properties, environment, location or vital spatial clearances of the components, assemblies or systems, as manufactured by General Motors, including but not limited to those listed below (if equipped):

Air Induction System (tuning elements)	Intake system (Air Induction System (i.e. Air filter, Mass Air flow (MAF) sensor, ducts))
Alternator	Power steering pump
Axles/halfshafts/propshaft	Powertrain control and logic
Components for AWD system (axle, propshaft, PTU)	Powertrain cooling fan and motor assemblies
Engine assembly	Radiator/condenser assembly to body seals
Exhaust System	Tires (including correct tire pressure)
Exterior noise generating devices	Transmission/Transaxle assembly
Exterior rearview mirror assemblies	Underbody shields including air deflector
Front of dash sound deadening material	Wheel house liners and shields
Hood assembly including sound deadening material and seals	

- B. Final compliance with CMVSS 1106 is the responsibility of the final stage manufacturer for any modifications, added material, components, or systems.

INTERFERENCE CAUSING EQUIPMENT STANDARD (CANADA ONLY) – ICES-002

Applies to all types of Incomplete Vehicles Contained in this Document

TYPE 1 The following statement is applicable to all types of incomplete vehicles propelled by an internal combustion engine, electrical means or both contained in this document (unless otherwise noted on the cover).

This incomplete vehicle, when completed, will conform to the performance requirements of the above standard provided no alterations are made which affect the function, physical, chemical, or mechanical properties, environment, location or vital spatial clearances of the components, assemblies or systems, as manufactured by General Motors, including but not limited to those listed below:

Low voltage battery	Charging System
High voltage battery	Ignition system
Electric propulsion system	BCM/SDM

Each vehicle propelled by an internal combustion engine, electrical means or both shall bear a bi-lingual label that represents the manufacturer's Self-Declaration of Compliance (SDoC) to Innovation, Science and Economic Development Canada ICES-002. This label shall be permanently affixed to the vehicle propelled by an internal combustion engine, electrical means or both or displayed electronically and its text must be clearly legible.

The final stage manufacturer must provide a statement of compliance on the Final Stage Manufacturer's Compliance Label or an additional label with the following bilingual information in order to comply with Industry Canada's Interference Causing Equipment Standard ICES/NMB-002:

ICES/NMB-002

CMVSS 101 and FMVSS 101 – CONTROLS AND DISPLAYS
Applies to all types of Incomplete Vehicles Contained in this Document

TYPE 1 The following statement is applicable to all types of Incomplete Vehicles contained in this document as noted above (unless otherwise noted on the cover).

This incomplete vehicle, when completed, will conform to CMVSS 101 and FMVSS 101 providing no alterations are made which affect the size, location, identification or illumination of the controls and displays or the location, travel and type of driver's seat, as manufactured by General Motors. If the driver's seat is installed by the intermediate or final stage manufacturer, the "H" point must be located as shown in the "Body Builder Manuals" on the **GM Upfitter Integration website located at www.gmupfitter.com**

The following controls must be operable, and the following displays for the following functions and malfunctions shall be fitted in such a manner that they are identifiable, by the driver while the driver is seated in the driver's designated seating position with the driver's seat belt fastened around the driver in accordance with the manufacturer's instructions:

Hand operated controls (if equipped):

Automatic vehicle speed (cruise control)	Ignition (switch)
Clearance lamps (switch)	Illumination intensity
Clutch pedal	Manual choke
Driver's sunvisor	Master lighting switch
Engine start	Position, side marker, end-outline marker, identification or clearance lamps
Engine stop	Rear window defogging and defrosting systems
Electronic stability control system "off"	Steering wheel
Hand throttle	Tail lamps
Hazard warning signal	Transaxle/transmission shifter (except transfer case)
Hazard warning switch	Turn signal
Headlamps	Windshield defogging and defrosting systems
Headlamp high or low beam switch	Windshield washer (washing system)
Heating and air conditioning fan	Windshield wiper (wiping system)
Heating and air conditioning system	
Horn	
Identification lamps (switch)	

Foot operated controls (if equipped):

Accelerator	Service brake (pedal)
Clutch	Tail lamp
Headlamp high or low beam switch	Windshield washer (washing system)
High beam	Windshield wiper (wiping system)
Park brake (pedal)	

Displays (if equipped):

Air brake low pressure	Headlamp high beam
Air bag system readiness	High beam
Antilock brake system malfunction	Low brake air pressure telltale
Battery charging condition	Low brake fluid condition
Brake lining wear-out condition	Low tire pressure indication (see MVSS 138)
Brake system malfunction (Canada - ISO symbol)	Odometer (Canada must be metric)
Brake Pressure (system loss)	Parking brake applied
Electrical charge	Passenger air bag status
Electronic stability control system "off"	Regenerative brake system malfunction
Electronic stability control system malfunction	Seat belt (unfastened telltale)
Engine coolant temperature	Speedometer (Canada must be metric)
Engine oil pressure	Tire pressure monitoring system malfunction
Fuel level	Transmission control position
Gross loss of brake pressure condition	Turn signal(s)

If the intermediate or final stage manufacturer installs any of the above controls and displays, they must also meet the requirements of this standard.

**CMVSS 102 and FMVSS 102 – TRANSMISSION SHIFT POSITION
SEQUENCE, STARTER INTERLOCK, AND TRANSMISSION BRAKING EFFECT**
Refer to Vehicle Types, and Applicable “Mobility” Statements that follow

TYPE 2 The following statement is applicable to all incomplete vehicle types contained in this document and not equipped with a Mobility Package (unless otherwise noted on the cover).

This incomplete vehicle, when completed, will conform to CMVSS 102 and FMVSS 102 providing no alterations are made which affect the function, physical, chemical, or mechanical properties, environment, location or vital spatial clearances of the components, assemblies or systems, as manufactured by General Motors, including but not limited to those listed below (if equipped):

Automatic (AT) Transmission control and identification system, including but not limited to:

AT floor shift mechanism	Automatic transmission/transaxle assembly
AT gear ratios and final drive ratio	Brake - AT interlock controls
AT gear shift sequence and control logic (electrical or mechanical)	Engine starter interlock controls
AT neutral safety switch assembly and wire	AT shift position pattern
AT position indicator linkage and display	Vehicle wiring harnesses
AT steering column assembly	

TYPE 3 The following statement is applicable to all incomplete vehicle types contained in this document and equipped with a Mobility Package (unless otherwise noted on the cover).

Conformity with CMVSS 102 and FMVSS 102 cannot be determined based upon the components supplied on the incomplete vehicle, and General Motors makes no representation to conformity with the standard.

CMVSS 103 and FMVSS 103 – WINDSHIELD DEFROSTING AND DEFOGGING SYSTEMS
Applies to all types of Incomplete Vehicles contained in this Document

TYPE 1 The following statement is applicable to all types of incomplete vehicles contained in this document (unless otherwise noted on the cover).

This incomplete vehicle, when completed, will conform to CMVSS 103 and FMVSS 103 providing no alterations are made which affect the function, physical, chemical, or mechanical properties, environment, location or vital spatial clearances of the components, assemblies or systems, as manufactured by General Motors, including but not limited to those listed below (if equipped):

Windshield defrosting and defogging systems, including but not limited to:

Chassis and instrument panel wiring harness assembly	Heater and air conditioning wiring harness
Defroster air distributor assembly (manifold)	Heater and defroster assembly (including motor and blower)
Defroster air duct assembly	Heater and defroster control (electrical, mechanical, vacuum)
Defroster air hoses (distributor to nozzle)	Heater and radiator hoses/hose assemblies
Defroster air to windshield outlet assembly (nozzle) (it affects blower speed)	Heater blower motor speed control
Defroster outlet to heater assembly adapter	Side window defroster ducts
Engine control, software and calibration	Vacuum control hoses and electric actuators
Engine coolant pump	Windshield assembly
Engine water outlet thermostat assembly	

CMVSS 104 and FMVSS 104 – WINDSHIELD WIPING AND WASHING SYSTEMS

Applies to all types of Incomplete Vehicles contained in this Document

TYPE 1 The following statement is applicable to all types of incomplete vehicles contained in this document (unless otherwise noted on the cover).

This incomplete vehicle, when completed, will conform to CMVSS 104 and FMVSS 104 providing no alterations are made which affect the function, physical, chemical, or mechanical properties, environment, location or vital spatial clearances of the components, assemblies or systems, as manufactured by General Motors, including but not limited to those listed below (if equipped):

Windshield wiping and washing systems, including but not limited to:

- | | |
|--|---|
| Vehicle wiring harness and electrical controls | Windshield washing system hoses |
| Washer reservoir cap | Windshield wiper arm assembly |
| Water reservoir filler assembly | Windshield wiper blade assembly |
| Windshield assembly | Windshield wiper linkage assembly |
| Windshield module attachments | Windshield wiper/washer control |
| Windshield washer fluid reservoir | Windshield wiper/washer motor/pump assembly |
| Windshield washer nozzle | |

CMVSS 105 and FMVSS 105 – HYDRAULIC AND ELECTRIC BRAKE SYSTEMS

Applies to all types of Incomplete Vehicles Contained in this Document

Greater than 3500 kg (7,716 lb.) GVWR

TYPE 2 The following statement is applicable to all types of Incomplete Vehicles contained in this document with a greater than 3500 kg (7,716 lb.) GVWR, (unless otherwise noted on the cover).

This incomplete vehicle when completed will conform to CMVSS 105 and FMVSS 105 provided it is completed in accordance with the following specific conditions by the (intermediate and) final stage manufacturer:

A. Providing no alterations are made which affect the function, physical, chemical, or mechanical properties, environment, location or vital spatial clearances of the components, assemblies or systems, as manufactured by General Motors, including but not limited to those listed below (if equipped):

- | | |
|--|---|
| Anti-Lock Brake System | Hydraulic brake lines, fittings and routings |
| Brake assemblies and components (service/parking) - (power boosters, master cylinder, wheel cylinder, calipers, wheel speed sensor, wheel speed sensor wiring, brake lining, etc.) | Hydraulic brake hoses and mounting brackets |
| Brake pedal, brake switch, parking brake pedal or park brake switch and related mechanical components | Hydraulic brake valves and components |
| Brake system electrical controls and logic | Master cylinder-warning statement |
| Gauges and warning devices, and statements | Parking brake actuator and related electrical and mechanical components |
| Hydraulic brake fluid and reservoirs | Owner Manual instructions |
| | Power steering or vacuum lines and routing |
| | Power steering or vacuum pump |
| | Shocks, springs and other suspension components |
| | Tires and Wheels |
| | Vacuum brake lines, fittings and routings |
| | Vehicle wiring harnesses |
| | Electric parking brake and wheel speed sensor wiring harness, attaching brackets, and mounting hardware |
| | Wheelbases |

B. GVWR, GAWR front and rear weight ratings as listed on the Incomplete Vehicle Label affixed to the front cover of this document must not be exceeded.

C. The center of gravity of the total vehicle falls within the areas referenced on the "ALLOWABLE CENTER OF GRAVITY CHART" that follows. Instructions for determining the allowable center of gravity variation are listed below:

These charts detail the envelope of allowable center of gravity variation for completed vehicles. This is significant for the lightly loaded portion of FMVSS 105, which is defined as curb plus 181.4 kg (400 lb.) distributed in the driver-passenger area of the vehicle for vehicles with GVWR of 4536 kg (10,000 lb.) or less or as curb plus 226.8 kg (500 lb.) distributed in the driver-passenger area of the vehicle for vehicles with GVWR greater than 4536 kg (10,000 lb.).

The lightly loaded center of gravity of complete vehicles needs to be restricted so it will meet FMVSS 105 stopping distances. The laden center of gravity does not need to be specified as it is controlled within the CMVSS 105 and FMVSS 105 test procedure by specific instructions as to how ballast is to be placed (while height is not controlled, it is assumed that for test purposes it would be reasonable).

For upfitter use, the center of gravity location can be approximated by the following formula:

$$d = \frac{[Wrc + Wrb + [(Hp)(Wp)/WB]] WB}{Wt}$$

$$h = \frac{[h1Wc + h2Wb + (h3)(Wp)]}{Wt}$$

- d = horizontal distance from front wheels to completed vehicle center of gravity mm (in)
- h = vertical distance from ground to completed vehicle center of gravity mm (in)
- Wrc = rear component of Chassis weight kg (lb.)
- Wrb = rear component of body weight kg (lb.)
- WB = vehicle wheelbase mm (in)
- Wt = total weight of chassis and body kg (lb.) plus 181.4 kg (400 lb.) for vehicles with GVWR of 4536 kg (10,000 lb.) or less.
- Wt = total weight of chassis and body kg (lb.) plus 226.8 kg (500 lb.) for vehicles with GVWR greater than 4536 kg (10,000 lb.).
- h1 = center of gravity height from ground of the Bare Chassis = 800 mm (31.5 in)
- Wc = total weight of Chassis kg (lb.)
- h2 = center of gravity height of body from ground mm (in)
- Wb = total weight of body kg (lb.)
- Wp = 181.4 kg (400 lb.) Amount from lightly loaded definition that is evenly distributed in driver-passenger area of vehicle for vehicles with GVWR of 4536 kg (10,000 lb.) or less.
- Wp = 226.8 kg (500 lb.) Amount from lightly loaded definition that is evenly distributed in driver-passenger area of vehicle for vehicles with GVWR greater than 4536 kg (10,000 lb.).
- Hp = 1543 mm (60.75 in) Horizontal distance from front axle to center of gravity of 181.4 kg (400 lb.) or 226.8 kg (500 lb.) evenly distributed in driver-passenger area of vehicle.
- h3 = 1075 mm (42.32 in) Vertical center of gravity height of 181.4 kg (400 lb.) evenly distributed in driver-passenger area for vehicles with GVWR of 4536 kg (10,000 lb.) or less.
- h3 = 1075 mm (42.32 in) Vertical center of gravity height of 226.8 kg (500 lb.) evenly distributed in driver-passenger area for vehicles with GVWR greater than 4536 kg (10,000 lb.).

CMVSS 105 and FMVSS 105 ALLOWABLE CENTER OF GRAVITY CHARTS

#	Vehicle Model	GVWR kg (lb)	Brake System RPO's	Wheel Base mm (in)	Rear Wheel Config	Pick-Up Box Removal									
						Coordinates of Allowable C/G Variation at CMVSS / FMVSS Unladen, Curb Weight + 181.4 kg (400 lb.) or 226.8 kg (500 lb.) as defined by CMVSS 105 and FMVSS 105 mm (in)								Fwd C/G Limit mm (in)	RRwd C/G Limit mm (in)
						Trapezoid Coordinates mm (in)						E	F		
						H ₁	H ₂	A	B	C	D				
1	C20903	4491 (9900)	J61 &SRW	3595 (141.5)	SRW	304.8 (12.0)	1219.2 (48.0)	1193 (47.0)	1446 (56.9)	2571 (101.2)	2825 (111.2)	1258 (49.5)	2319 (91.3)		
2	C20903	4536 (10000)	J61 &SRW	3595 (141.5)	SRW	304.8 (12.0)	1219.2 (48.0)	1193 (47.0)	1446 (56.9)	2571 (101.2)	2825 (111.2)	1258 (49.5)	2319 (91.3)		
3	C20903	4695 (10350)	J61 &SRW	3595 (141.5)	SRW	304.8 (12.0)	1219.2 (48.0)	995 (39.2)	1206 (47.5)	2741 (107.9)	2953 (116.3)	1186 (46.7)	2423 (95.4)		
4	C20903	4785 (10550)	J61 &SRW	3595 (141.5)	SRW	304.8 (12.0)	1219.2 (48.0)	995 (39.2)	1206 (47.5)	2741 (107.9)	2953 (116.3)	1186 (46.7)	2423 (95.4)		
5	C20903	4876 (10750)	J61 &SRW	3595 (141.5)	SRW	304.8 (12.0)	1219.2 (48.0)	995 (39.2)	1206 (47.5)	2741 (107.9)	2953 (116.3)	1186 (46.7)	2423 (95.4)		
6	C20903	5080 (11200)	J61 &SRW	3595 (141.5)	SRW	304.8 (12.0)	1219.2 (48.0)	995 (39.2)	1206 (47.5)	2741 (107.9)	2953 (116.3)	1186 (46.7)	2423 (95.4)		
7	C20943	4491 (9900)	J61 &SRW	4369 (172.0)	SRW	304.8 (12.0)	1219.2 (48.0)	1431 (56.3)	1685 (66.3)	3107 (122.3)	3361 (132.3)	1529 (60.2)	2818 (110.9)		
8	C20943	4536 (10000)	J61 &SRW	4369 (172.0)	SRW	304.8 (12.0)	1219.2 (48.0)	1431 (56.3)	1685 (66.3)	3107 (122.3)	3361 (132.3)	1529 (60.2)	2818 (110.9)		
9	C20943	4672 (10300)	J61 &SRW	4369 (172.0)	SRW	304.8 (12.0)	1219.2 (48.0)	1194 (47.0)	1405 (55.3)	3316 (130.6)	3528 (138.9)	1442 (56.8)	2945 (115.9)		
10	C20943	4853 (10700)	J61 &SRW	4369 (172.0)	SRW	304.8 (12.0)	1219.2 (48.0)	1194 (47.0)	1405 (55.3)	3316 (130.6)	3528 (138.9)	1442 (56.8)	2945 (115.9)		
11	C20943	4989 (11000)	J61 &SRW	4369 (172.0)	SRW	304.8 (12.0)	1219.2 (48.0)	1194 (47.0)	1405 (55.3)	3316 (130.6)	3528 (138.9)	1442 (56.8)	2945 (115.9)		
12	C20943	5080 (11200)	J61 &SRW	4369 (172.0)	SRW	304.8 (12.0)	1219.2 (48.0)	1194 (47.0)	1405 (55.3)	3316 (130.6)	3528 (138.9)	1442 (56.8)	2945 (115.9)		
13	C20943	5239 (11550)	J61 &SRW	4369 (172.0)	SRW	304.8 (12.0)	1219.2 (48.0)	1194 (47.0)	1405 (55.3)	3316 (130.6)	3528 (138.9)	1442 (56.8)	2945 (115.9)		
14	C20953	4491 (9900)	J61 &SRW	4127 (162.5)	SRW	304.8 (12.0)	1219.2 (48.0)	1357 (53.4)	1610 (63.4)	2939 (115.7)	3193 (125.7)	1444 (56.9)	2662 (104.8)		
15	C20953	4536 (10000)	J61 &SRW	4127 (162.5)	SRW	304.8 (12.0)	1219.2 (48.0)	1357 (53.4)	1610 (63.4)	2939 (115.7)	3193 (125.7)	1444 (56.9)	2662 (104.8)		
16	C20953	4627 (10200)	J61 &SRW	4127 (162.5)	SRW	304.8 (12.0)	1219.2 (48.0)	1131 (44.5)	1343 (52.9)	3137 (123.5)	3348 (131.8)	1362 (53.6)	2782 (109.5)		
17	C20953	4808 (10600)	J61 &SRW	4127 (162.5)	SRW	304.8 (12.0)	1219.2 (48.0)	1131 (44.5)	1343 (52.9)	3137 (123.5)	3348 (131.8)	1362 (53.6)	2782 (109.5)		
18	C20953	4944 (10900)	J61 &SRW	4127 (162.5)	SRW	304.8 (12.0)	1219.2 (48.0)	1131 (44.5)	1343 (52.9)	3137 (123.5)	3348 (131.8)	1362 (53.6)	2782 (109.5)		

#	Vehicle Model	GVWR kg (lb)	Brake System RPO's	Wheel Base mm (in)	Rear Wheel Config	Pick-Up Box Removal							
						Coordinates of Allowable C/G Variation at CMVSS / FMVSS Unladen, Curb Weight + 181.4 kg (400 lb.) or 226.8 kg (500 lb.) as defined by CMVSS 105 and FMVSS 105 mm (in)							
						Trapezoid Coordinates mm (in)						Fwd C/G Limit mm (in)	RRwd C/G Limit mm (in)
						H ₁	H ₂	A	B	C	D	E	F
19	C20953	5035 (11100)	J61 &SRW	4127 (162.5)	SRW	304.8 (12.0)	1219.2 (48.0)	1131 (44.5)	1343 (52.9)	3137 (123.5)	3348 (131.8)	1362 (53.6)	2782 (109.5)
20	C30743	5080 (11200)	J61 &SRW	4037 (158.9)	SRW	304.8 (12.0)	1219.2 (48.0)	1108 (43.6)	1320 (52.0)	3070 (120.9)	3281 (129.2)	1332 (52.4)	2721 (107.1)
21	C30743	5330 (11750)	J61 &SRW	4037 (158.9)	SRW	304.8 (12.0)	1219.2 (48.0)	1108 (43.6)	1320 (52.0)	3070 (120.9)	3281 (129.2)	1332 (52.4)	2721 (107.1)
22	C30903	4967 (10950)	J61 &SRW	3595 (141.5)	SRW	304.8 (12.0)	1219.2 (48.0)	995 (39.2)	1206 (47.5)	2741 (107.9)	2953 (116.3)	1186 (46.7)	2423 (95.4)
23	C30903	5216 (11500)	J61 &SRW	3595 (141.5)	SRW	304.8 (12.0)	1219.2 (48.0)	995 (39.2)	1206 (47.5)	2741 (107.9)	2953 (116.3)	1186 (46.7)	2423 (95.4)
24	C30903	6350 (14000)	J61 &DZW	3595 (141.5)	DRW	304.8 (12.0)	1219.2 (48.0)	995 (39.2)	1206 (47.5)	2741 (107.9)	2953 (116.3)	1186 (46.7)	2696 (106.1)
25	C30943	5148 (11350)	J61 &SRW	4369 (172.0)	SRW	304.8 (12.0)	1219.2 (48.0)	1194 (47.0)	1405 (55.3)	3316 (130.6)	3528 (138.9)	1442 (56.8)	2945 (115.9)
26	C30943	5398 (11900)	J61 &SRW	4369 (172.0)	SRW	304.8 (12.0)	1219.2 (48.0)	1194 (47.0)	1405 (55.3)	3316 (130.6)	3528 (138.9)	1442 (56.8)	2945 (115.9)
27	C30943	6350 (14000)	J61 &DZW	4369 (172.0)	DRW	304.8 (12.0)	1219.2 (48.0)	1194 (47.0)	1405 (55.3)	3316 (130.6)	3528 (138.9)	1442 (56.8)	3277 (129.0)
28	C30953	5126 (11300)	J61 &SRW	4127 (162.5)	SRW	304.8 (12.0)	1219.2 (48.0)	1131 (44.5)	1343 (52.9)	3137 (123.5)	3348 (131.8)	1362 (53.6)	2782 (109.5)
29	C30953	5375 (11850)	J61 &SRW	4127 (162.5)	SRW	304.8 (12.0)	1219.2 (48.0)	1131 (44.5)	1343 (52.9)	3137 (123.5)	3348 (131.8)	1362 (53.6)	2782 (109.5)
30	C30953	6350 (14000)	J61 &DZW	4127 (162.5)	DRW	304.8 (12.0)	1219.2 (48.0)	1131 (44.5)	1343 (52.9)	3137 (123.5)	3348 (131.8)	1362 (53.6)	3095 (121.9)
31	C31003	6350 (14000)	J61 &DZW	3716 (146.3)	DRW	304.8 (12.0)	1219.2 (48.0)	1026 (40.4)	1237 (48.7)	2831 (111.5)	3043 (119.8)	1226 (48.3)	2787 (109.7)
32	C31403	6350 (14000)	J61 &DZW	4338 (170.8)	DRW	304.8 (12.0)	1219.2 (48.0)	1186 (46.7)	1397 (55.0)	3293 (129.6)	3505 (138.0)	1432 (56.4)	3254 (128.1)
33	C31043	6350 (14000)	J61 &DZW	4490 (176.8)	DRW	304.8 (12.0)	1219.2 (48.0)	1225 (48.2)	1436 (56.5)	3406 (134.1)	3618 (142.4)	1482 (58.3)	3368 (132.6)
34	K20903	4491 (9900)	J61 &SRW	3595 (141.5)	SRW	304.8 (12.0)	1219.2 (48.0)	1193 (47.0)	1446 (56.9)	2571 (101.2)	2825 (111.2)	1258 (49.5)	2319 (91.3)
35	K20903	4536 (10000)	J61 &SRW	3595 (141.5)	SRW	304.8 (12.0)	1219.2 (48.0)	1193 (47.0)	1446 (56.9)	2571 (101.2)	2825 (111.2)	1258 (49.5)	2319 (91.3)
36	K20903	4649 (10250)	J61 &SRW	3595 (141.5)	SRW	304.8 (12.0)	1219.2 (48.0)	995 (39.2)	1206 (47.5)	2741 (107.9)	2953 (116.3)	1186 (46.7)	2423 (95.4)
37	K20903	4831 (10650)	J61 &SRW	3595 (141.5)	SRW	304.8 (12.0)	1219.2 (48.0)	995 (39.2)	1206 (47.5)	2741 (107.9)	2953 (116.3)	1186 (46.7)	2423 (95.4)
38	K20903	4944 (10900)	J61 &SRW	3595 (141.5)	SRW	304.8 (12.0)	1219.2 (48.0)	995 (39.2)	1206 (47.5)	2741 (107.9)	2953 (116.3)	1186 (46.7)	2423 (95.4)

#	Vehicle Model	GVWR kg (lb)	Brake System RPO's	Wheel Base mm (in)	Rear Wheel Config	Pick-Up Box Removal							
						Coordinates of Allowable C/G Variation at CMVSS / FMVSS Unladen, Curb Weight + 181.4 kg (400 lb.) or 226.8 kg (500 lb.) as defined by CMVSS 105 and FMVSS 105 mm (in)							
						Trapezoid Coordinates mm (in)						Fwd C/G Limit mm (in)	RRwd C/G Limit mm (in)
						H ₁	H ₂	A	B	C	D	E	F
39	K20903	4971 (10960)	J61 &SRW	3595 (141.5)	SRW	304.8 (12.0)	1219.2 (48.0)	995 (39.2)	1206 (47.5)	2741 (107.9)	2953 (116.3)	1186 (46.7)	2423 (95.4)
40	K20903	5001 (11025)	J61 &SRW	3595 (141.5)	SRW	304.8 (12.0)	1219.2 (48.0)	995 (39.2)	1206 (47.5)	2741 (107.9)	2953 (116.3)	1186 (46.7)	2423 (95.4)
41	K20943	4491 (9900)	J61 &SRW	4369 (172.0)	SRW	304.8 (12.0)	1219.2 (48.0)	1431 (56.3)	1685 (66.3)	3107 (122.3)	3361 (132.3)	1529 (60.2)	2818 (110.9)
42	K20943	4536 (10000)	J61 &SRW	4369 (172.0)	SRW	304.8 (12.0)	1219.2 (48.0)	1431 (56.3)	1685 (66.3)	3107 (122.3)	3361 (132.3)	1529 (60.2)	2818 (110.9)
43	K20943	4831 (10650)	J61 &SRW	4369 (172.0)	SRW	304.8 (12.0)	1219.2 (48.0)	1194 (47.0)	1405 (55.3)	3316 (130.6)	3528 (138.9)	1442 (56.8)	2945 (115.9)
44	K20943	5012 (11050)	J61 &SRW	4369 (172.0)	SRW	304.8 (12.0)	1219.2 (48.0)	1194 (47.0)	1405 (55.3)	3316 (130.6)	3528 (138.9)	1442 (56.8)	2945 (115.9)
45	K20943	5148 (11350)	J61 &SRW	4369 (172.0)	SRW	304.8 (12.0)	1219.2 (48.0)	1194 (47.0)	1405 (55.3)	3316 (130.6)	3528 (138.9)	1442 (56.8)	2945 (115.9)
46	K20943	5239 (11550)	J61 &SRW	4369 (172.0)	SRW	304.8 (12.0)	1219.2 (48.0)	1194 (47.0)	1405 (55.3)	3316 (130.6)	3528 (138.9)	1442 (56.8)	2945 (115.9)
47	K20953	4491 (9900)	J61 &SRW	4127 (162.5)	SRW	304.8 (12.0)	1219.2 (48.0)	1357 (53.4)	1610 (63.4)	2939 (115.7)	3193 (125.7)	1444 (56.9)	2662 (104.8)
48	K20953	4536 (10000)	J61 &SRW	4127 (162.5)	SRW	304.8 (12.0)	1219.2 (48.0)	1357 (53.4)	1610 (63.4)	2939 (115.7)	3193 (125.7)	1444 (56.9)	2662 (104.8)
49	K20953	4763 (10500)	J61 &SRW	4127 (162.5)	SRW	304.8 (12.0)	1219.2 (48.0)	1131 (44.5)	1343 (52.9)	3137 (123.5)	3348 (131.8)	1362 (53.6)	2782 (109.5)
50	K20953	4967 (10950)	J61 &SRW	4127 (162.5)	SRW	304.8 (12.0)	1219.2 (48.0)	1131 (44.5)	1343 (52.9)	3137 (123.5)	3348 (131.8)	1362 (53.6)	2782 (109.5)
51	K20953	5080 (11200)	J61 &SRW	4127 (162.5)	SRW	304.8 (12.0)	1219.2 (48.0)	1131 (44.5)	1343 (52.9)	3137 (123.5)	3348 (131.8)	1362 (53.6)	2782 (109.5)
52	K20953	5194 (11450)	J61 &SRW	4127 (162.5)	SRW	304.8 (12.0)	1219.2 (48.0)	1131 (44.5)	1343 (52.9)	3137 (123.5)	3348 (131.8)	1362 (53.6)	2782 (109.5)
53	K30903	5126 (11300)	J61 &SRW	3595 (141.5)	SRW	304.8 (12.0)	1219.2 (48.0)	995 (39.2)	1206 (47.5)	2741 (107.9)	2953 (116.3)	1186 (46.7)	2423 (95.4)
54	K30903	5352 (11800)	J61 &SRW	3595 (141.5)	SRW	304.8 (12.0)	1219.2 (48.0)	995 (39.2)	1206 (47.5)	2741 (107.9)	2953 (116.3)	1186 (46.7)	2423 (95.4)
55	K30903	6350 (14000)	J61 &DZW	3595 (141.5)	DRW	304.8 (12.0)	1219.2 (48.0)	995 (39.2)	1206 (47.5)	2741 (107.9)	2953 (116.3)	1186 (46.7)	2696 (106.1)
56	K30943	5307 (11700)	J61 &SRW	4369 (172.0)	SRW	304.8 (12.0)	1219.2 (48.0)	1194 (47.0)	1405 (55.3)	3316 (130.6)	3528 (138.9)	1442 (56.8)	2945 (115.9)
57	K30943	5556 (12250)	J61 &SRW	4369 (172.0)	SRW	304.8 (12.0)	1219.2 (48.0)	1194 (47.0)	1405 (55.3)	3316 (130.6)	3528 (138.9)	1442 (56.8)	2945 (115.9)
58	K30943	6350 (14000)	J61 &DZW	4369 (172.0)	DRW	304.8 (12.0)	1219.2 (48.0)	1194 (47.0)	1405 (55.3)	3316 (130.6)	3528 (138.9)	1442 (56.8)	3277 (129.0)

#	Vehicle Model	GVWR kg (lb)	Brake System RPO's	Wheel Base mm (in)	Rear Wheel Config	Pick-Up Box Removal							
						Coordinates of Allowable C/G Variation at CMVSS / FMVSS Unladen, Curb Weight + 181.4 kg (400 lb.) or 226.8 kg (500 lb.) as defined by CMVSS 105 and FMVSS 105 mm (in)							
						Trapezoid Coordinates mm (in)						Fwd C/G Limit mm (in)	RRwd C/G Limit mm (in)
						H ₁	H ₂	A	B	C	D	E	F
59	K30953	5262 (11600)	J61 &SRW	4127 (162.5)	SRW	304.8 (12.0)	1219.2 (48.0)	1131 (44.5)	1343 (52.9)	3137 (123.5)	3348 (131.8)	1362 (53.6)	2782 (109.5)
60	K30953	5511 (12150)	J61 &SRW	4127 (162.5)	SRW	304.8 (12.0)	1219.2 (48.0)	1131 (44.5)	1343 (52.9)	3137 (123.5)	3348 (131.8)	1362 (53.6)	2782 (109.5)
61	K30953	6350 (14000)	J61 &DZW	4127 (162.5)	DRW	304.8 (12.0)	1219.2 (48.0)	1131 (44.5)	1343 (52.9)	3137 (123.5)	3348 (131.8)	1362 (53.6)	3095 (121.9)
62	K31003	6350 (14000)	J61 &DZW	3716 (146.3)	DRW	304.8 (12.0)	1219.2 (48.0)	1026 (40.4)	1237 (48.7)	2831 (111.5)	3043 (119.8)	1226 (48.3)	2787 (109.7)
63	K31403	6350 (14000)	J61 &DZW	4338 (170.8)	DRW	304.8 (12.0)	1219.2 (48.0)	1186 (46.7)	1397 (55.0)	3293 (129.6)	3505 (138.0)	1432 (56.4)	3254 (128.1)
64	K31043	6350 (14000)	J61 &DZW	4490 (176.8)	DRW	304.8 (12.0)	1219.2 (48.0)	1225 (48.2)	1436 (56.5)	3406 (134.1)	3618 (142.4)	1482 (58.3)	3368 (132.6)

C/G = Center of Gravity

SRW = Single Rear Wheel (RPO SRW - CHASSIS SINGLE REAR WHEEL, RIDE & HANDLING)

DRW = Dual Rear Wheel (RPO DZW - CHASSIS DUAL REAR WHEEL, RIDE & HANDLING)

Brake Systems: RPO J61 BRAKE SYSTEM POWER, FRT & RR DISC, ABS, 17"

Hydraulic Powered Boosters

RPO's J61&SRW (Single Rear Wheel vehicle)

RPO's J61&DZW (Dual Rear Wheel vehicle)

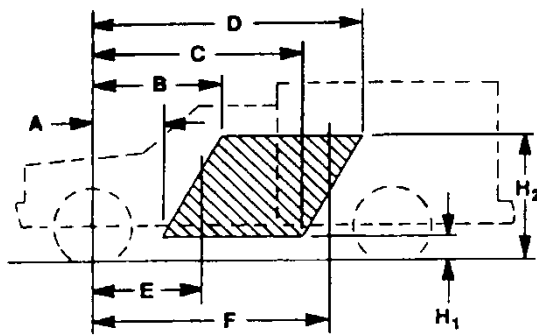

C/G of vehicle in CMVSS or FMVSS unladen condition [Curb + 181.4 kg. (400 lb.) or Curb + 226.8 kg. (500 lb.) as defined by CMVSS 105 and FMVSS 105] must be inside shaded area – that is, the C/G must be within the trapezoid formed by the coordinates A, B, C, D, H1, & H2, plus the C/G must be to the rear of vertical line E and forward of vertical line F.

CMVSS 106 and FMVSS 106 – BRAKE HOSES, HYDRAULIC, AIR AND VACUUM
Applies to all types of Incomplete Vehicles contained in this Document

TYPE 1 The following statement is applicable to all types of incomplete vehicles contained in this document (unless otherwise noted on the cover).

This incomplete vehicle, when completed, will conform to CMVSS 106 and FMVSS 106 providing no alterations are made which affect the function, physical, chemical, or mechanical properties, environment, location or vital spatial clearances of the components, assemblies or systems, as manufactured by General Motors, including but not limited to those listed below:

- | | |
|---|-----------------------|
| Hydraulic, Air, and Vacuum Brake Hoses and assemblies | Labeling requirements |
|---|-----------------------|

CMVSS 108 – DAYTIME RUNNING LAMPS
Applies to all types of Incomplete Vehicles contained in this Document

TYPE 1 The following statement is applicable to all types of incomplete vehicles contained in this document (unless otherwise noted on the cover).

This incomplete vehicle, when completed will conform to the Daytime Running Lamps (DRL) requirements of CMVSS108 providing no alterations are made to the ignition switch, DRL system components or wiring, and any vehicle forward lighting as manufactured by General Motors.

CMVSS 108 and FMVSS 108 – LAMPS, REFLECTIVE DEVICES AND ASSOCIATED EQUIPMENT
Pick-up and Utility

TYPE 1 The following statement is applicable to Pick-up and Utility types of incomplete vehicles contained in this document (unless otherwise noted on the cover).

This incomplete vehicle, when completed, will conform to CMVSS 108 and FMVSS 108 providing no alterations are made which affect the function, physical, chemical, or mechanical properties, environment, location or vital spatial clearances of the components, assemblies or systems, as manufactured by General Motors, including but not limited to those listed below:

- | | |
|--|-----------------------------|
| Back-up lamps | Headlamp dimmer switch |
| Body control module (BCM) | Headlamp highbeam indicator |
| Center high mounted stop lamp | License plate lamp |
| Daytime running lamps controls and wiring (Canada) | Owner Manual instructions |
| | Park lamps |

Fog lamps (if equipped)
 Front side marker lamps
 Front side reflex reflectors
 Front clearance lamps (if equipped)
 Front identification lamps (if equipped)
 Front turn signal lamps
 Hazard warning flasher
 Hazard warning signal operating unit
 Headlamps

Rear clearance lamps (if equipped)
 Rear identification lamps (if equipped)
 Rear side marker lamps
 Rear side reflex reflectors
 Rear reflex reflectors
 Rear turn signal lamps
 Stop lamps
 Tail lamps
 Turn signal control

NOTES: Pick-ups are equipped with a turn signal lamp failure feature. In order to maintain operation of the turn signal failure feature, the LH and RH taillamp assemblies must each contain two (2) operational bulbs, of the bulb designation number as manufactured by General Motors.

Utilities are equipped with a turn signal lamp failure feature. In order to maintain operation of the turn signal bulb outage feature, the LH and RH taillamp assemblies must each contain one (1) operational bulb of the bulb designation number as manufactured by General Motors.

**CMVSS 108 and FMVSS 108 – LAMPS, REFLECTIVE DEVICES
 AND ASSOCIATED EQUIPMENT
Chassis Cab**

TYPE 2 The following statement is applicable to Chassis Cab types of incomplete vehicles contained in this document (unless otherwise noted on the cover.)

The chassis cab incomplete vehicle, if equipped with factory installed stop/tail/back-up/ lamp assemblies, when completed will conform to CMVSS 108 and FMVSS 108 providing the following conditions are met:

- A. Each of these devices installed on the incomplete vehicle have no alterations made which affect the function, physical, chemical, or mechanical properties, environment, location or vital spatial clearances of the components, assemblies or systems, as manufactured by General Motors, including but not limited to those listed below:

Back-up lamps	Hazard warning flasher
Body control module (BCM)	Hazard warning signal operating unit
Center high mounted stop lamp	Headlamps
Daytime running lamps controls and wiring (Canada)	Headlamp dimmer switch
Fog lamps (if equipped)	Headlamp highbeam indicator
Front side marker lamps	License plate lamp
Front side reflex reflectors	Owner manual instructions
Front clearance lamps (if equipped and located as near as practicable to the upper left and right extreme edges)	Park lamps
Front identification lamps (if equipped and located at the highest point of the vehicle)	Rear reflex reflectors
Front turn signal lamps	Rear turn signal lamps
	Stop lamps
	Tail lamps
	Turn signal control

1. No part of the completed vehicle shall be installed to prevent any of the devices listed above from meeting their required photometric output at the specified test points. If such interference exists, the applicable devices may have to be relocated or additional devices added to meet the requirements of CMVSS 108 and FMVSS 108. Any CMVSS 108 or FMVSS 108 part shall not be painted.
2. A. The following additional devices must be installed on the body and meet all requirements of CMVSS 108 and FMVSS 108:

Rear side marker lamps	Rear side reflex reflectors
------------------------	-----------------------------

B. If not equipped with factory installed stop/tail/back-up/ lamp assemblies, the following additional devices must be installed on the body and meet all requirements of CMVSS 108 and FMVSS 108:

Rear side marker lamps
Back-up lamps
License plate lamp
Tail lamps

Rear side reflex reflectors
Rear reflex reflectors
Rear turn signal lamps
Stop lamps

3. The following additional device must be installed on the body and meet all requirements of CMVSS 108 and FMVSS 108 if the body width is less than 203.2 cm (80 in) and has a GVWR of 4536 kg (10,000 lb.) or less and the original equipment center high mounted stop lamp has been removed or obstructed:

Center high mounted stop lamp

4. The following additional devices must be installed on the body and meet all requirements of CMVSS 108 and FMVSS 108 if the body width is greater than or equal to 203.2 cm (80 in):

Front clearance lamps (if body is wider than the cab mounted lamps)
Front identification lamps (if the body is higher than cab mounted lamps)

Rear clearance lamps
Rear identification lamps
Front and rear clearance lamps
Front and rear identification lamps

5. The following additional devices must be installed on the body and meet all requirements of CMVSS 108 and FMVSS 108 if the overall vehicle length is greater than or equal to 9.144 m (30 ft):

Intermediate side marker lamps

Intermediate side reflex reflectors

- B. No alterations are made which affect the function, physical, chemical, or mechanical properties, environment, location or vital spatial clearances of the components, assemblies or systems including but not limited to those listed in A, 1, above.

TYPE 3 The following statement is applicable to the turn signal lamp failure requirements for Chassis Cab types of incomplete vehicles contained in this document and completed with a body width less than 203.2 cm (80 in), and not equipped to tow a trailer. (Unless otherwise noted on the cover).

Conformity with CMVSS 108 and FMVSS 108 turn signal lamp failure requirements cannot be determined based upon the components supplied on the incomplete vehicle, and General Motors makes no representation to conformity with the standard.

CMVSS 110 and FMVSS 110 – TIRE SELECTION AND RIMS FOR MOTOR VEHICLES WITH A GVWR OF 4536 kg (10,000 lb.) OR LESS Applies to all types of Incomplete Vehicles contained in this Document

TYPE 2 The following statement is applicable to all types of incomplete vehicles contained in this document (unless otherwise noted on the cover).

This incomplete vehicle, when completed, will conform to CMVSS 110 and FMVSS 110, providing:

- A. No alterations are made which affect the function, physical or mechanical properties, environment, location or vital spatial clearances of the components, assemblies or systems, as manufactured by General Motors, including but not limited to:

Owner Manual instructions
Tires

Wheels

- B. GVWR, GAWR front and rear weight ratings as listed on the Incomplete Vehicle Label affixed to the front cover of this document are not exceeded.
- C. The tire and wheel information shown on the Incomplete Vehicle Document Label must be transferred to the final stage manufacturer's Certification Label and Tire Placard, providing no equipment or tire pressure changes are made, and the final stage manufacturer labels the vehicle in compliance with CMVSS 110 and FMVSS 110.

NOTE: Incomplete Vehicles referenced in this document may be shipped with reduced tire pressures for shipping purposes only.

CMVSS 111 and FMVSS 111 – REAR VISIBILITY
Applies to all types of Incomplete Vehicles contained in this Document
Without Shipped Loose Mirror, or Mirror Delete options

TYPE 1 The following statement is applicable to all types of incomplete vehicles contained in this document, without shipped loose mirror or mirror delete options (unless otherwise noted on the cover).

This incomplete vehicle will conform to CMVSS 111 and FMVSS 111 providing:

- A. No alterations or substitutions are made to the outside mirrors or inside mirrors furnished with the vehicle,
- B. The driver's seat location is not altered,
- C. The body width is not increased, and
- D. The body remains symmetrical about the vehicle centerline.
- E. The GVWR is not changed.

CMVSS 111 and FMVSS 111 – REAR VISIBILITY
Applies to all types of Incomplete Vehicles contained in this Document
With Shipped Loose Mirror, or Mirror Delete Options

TYPE 3 The following statement is applicable to all types of incomplete vehicles contained in this document with shipped loose mirror, or mirror delete options (unless otherwise noted on the cover).

Conformity with CMVSS 111 and FMVSS 111 cannot be determined based upon the components supplied on the incomplete vehicle, and General Motors makes no representation to conformity with the standard.

CMVSS111 and FMVSS 111 – REAR VISIBILITY CAMERA SYSTEMS
Pick-up or Utility Vehicle with a GVWR less than or equal to 4536 kg (10,000 lb.)

TYPE 1 The following statement is applicable to pick-up trucks or utility incomplete vehicles contained in this document 4536 kg (10,000 lb.) GVWR or less (unless otherwise noted on the cover).

This incomplete vehicle, when completed, will conform to FMVSS 111 S6.2 rear camera visibility system requirements providing there are no accessories, paint or decals added that obscure the video camera and no alterations are made which affect the function, physical, chemical, or mechanical properties, environment, location or vital spatial clearances of the components, assemblies or systems, as manufactured by General Motors, including but not limited to those listed below:

Body Control Module (BCM)
Camera lens and mounting

Video display
Wiring for video and camera

TYPE 1 The following statement is applicable to Chassis Cab incomplete vehicles contained in this document, 4536 kg (10,000 lb) GVWR or less (unless otherwise noted on the cover).

This incomplete vehicle, when completed, will conform to with CMVSS/FMVSS 111 S6.2.3 (response time), S6.2.4 (linger time), S6.2.5 (deactivation) and S6.2.6 (default view) providing no alterations are made which affect the function, physical, chemical, or mechanical properties, environment, location or vital spatial clearances of the components, assemblies or systems, as manufactured by General Motors, including but not limited to those listed below:

Body Control Module (BCM)

Video display

TYPE 2 The following statement is applicable to Chassis Cab incomplete vehicles contained in this document, 4536 kg (10,000 lb) GVWR or less (unless otherwise noted on the cover).

This incomplete vehicle, when completed, will conform to with CMVSS/FMVSS 111 S14.3 (durability requirements) provided the GM supplied camera is mounted in a location protected from the spray of water, mud and other substances onto the camera.

TYPE 3 The following statement is applicable to Chassis Cab incomplete vehicles contained in this document, 4536 kg (10,000 lb) GVWR or less (unless otherwise noted on the cover).

Conformity with CMVSS/FMVSS 111 S6.2.1 (field of view) and S6.2.2 (size) cannot be determined based upon the components supplied on the incomplete vehicle, and General Motors makes no representation to conformity with the standard.

CMVSS 113 and FMVSS 113 – HOOD LATCH SYSTEM
Applies to all types of Incomplete Vehicles contained in this Document

TYPE 1 The following statement is applicable to all types of incomplete vehicles contained in this document (unless otherwise noted on the cover).

This incomplete vehicle, when completed, will conform to CMVSS 113 and FMVSS 113 providing no alterations are made which affect the function, physical, chemical, or mechanical properties, environment, location or vital spatial clearances of the components, assemblies or systems, as manufactured by General Motors, including but not limited to those listed below:

Hood latch systems, which may include but are not limited to:

Hood latch (catch) assembly	Hood latch striker plate (hook) and reinforcements
Hood latch cable release system including controls	Hood latch support assembly
Hood latch pilot	

CMVSS 114 and FMVSS 114 – THEFT PROTECTION AND ROLLAWAY PREVENTION
Applies to all types of Incomplete Vehicles Contained in this Document
4536 kg (10,000 lb.) GVWR or less

TYPE 1 The following statement is applicable to all types of incomplete vehicles contained in this document, 4536 kg (10,000 lb.) GVWR or less (unless otherwise noted on the cover).

This incomplete vehicle, when completed, will conform to CMVSS 114 and FMVSS 114 providing no alterations are made which affect the function, physical, chemical, or mechanical properties, environment, location or vital spatial clearances of the components, assemblies or systems, as manufactured by General Motors, including but not limited to those listed below:

Brake-transaxle/transmission interlock controls	Owner Manual instructions
Electronic Immobilizer	Steering column lock assembly
Engine electronics (ECM/PCM/VCM)	Transaxle/Transmission assembly
Engine starter interlock controls	Transaxle/Transmission assembly neutral start
Ignition key	switch and wiring
Ignition key warning chime system	

CMVSS 115 – VEHICLE IDENTIFICATION NUMBER
Applies to all types of Incomplete Vehicles contained in this Document

TYPE 1 The following statement is applicable to all types of incomplete vehicles contained in this document (unless otherwise noted on the cover).

This incomplete vehicle, when completed, will conform to CMVSS 115, providing no alterations are made which affect the function, physical, chemical, or mechanical properties, environment, location or vital spatial clearances of the components, assemblies or systems, as manufactured by General Motors, including but not limited to those listed below:

Vehicle Identification Number
VIN label or plate

VIN plate fasteners

CMVSS 116 and FMVSS 116 – MOTOR VEHICLE BRAKE FLUIDS
Applies to all types of Incomplete Vehicles contained in this Document

TYPE 1 The following statement is applicable to all types of incomplete vehicles contained in this document (unless otherwise noted on the cover).

The hydraulic brake fluid in this incomplete vehicle, as manufactured by General Motors, will conform to CMVSS 116 and FMVSS 116 providing no alterations are made which affect the physical or chemical properties of the brake fluid.

**CMVSS 118 and FMVSS 118 – POWER OPERATED WINDOW, PARTITION
AND ROOF PANEL SYSTEMS**
Applies to all types of Incomplete Vehicles Contained in this Document
4536 kg (10,000 lb.) GVWR or less

TYPE 1 The following statement is applicable to all types of incomplete vehicles contained in this document, **4536 kg (10,000 lb.) GVWR or less (unless otherwise noted on the cover).**

This incomplete vehicle, if equipped by General Motors with power windows, when completed, will conform to CMVSS 118 and FMVSS 118 providing no alterations are made which affect the function, physical, chemical, or mechanical properties, environment, location or vital spatial clearances of the components, assemblies or systems, as manufactured by General Motors, including but not limited to those listed below:

Power window electrical system
Power window operating system

Power window operating system control logic
Window glazing material

Final compliance with CMVSS118 and FMVSS 118 is the responsibility of the final stage manufacturer for any modifications, or added material, components, or systems.

**CMVSS 120 and FMVSS 120 – TIRE SELECTION AND RIMS FOR MOTOR VEHICLES WITH A
GVWR OF MORE THAN 4536 kg (10,000 lb.)**
Applies to all types of Incomplete Vehicles contained in this Document

TYPE 2 The following statement is applicable to all types of incomplete vehicles contained in this document (unless otherwise noted on the cover).

This incomplete vehicle, when completed, will conform to CMVSS 120 and FMVSS 120, providing:

A. No alterations are made which affect the function, physical or mechanical properties, environment, location or vital spatial clearances of the components, assemblies or systems, as manufactured by General Motors, including but not limited to:

Owner Manual instructions
Tires

Wheels

B. GVWR, GAWR front and rear weight ratings as listed on the Incomplete Vehicle Label affixed to the front cover of this document are not exceeded.

- C. The tire and wheel information shown on the Incomplete Vehicle Document Label must be transferred to the final stage manufacturer's Certification Label providing no equipment or tire pressure changes are made, and the final stage manufacturer labels the vehicle in compliance with CMVSS 120 and FMVSS 120.

NOTE: Incomplete Vehicles referenced in this document may be shipped with reduced tire pressures for shipping purposes only.

CMVSS 124 and FMVSS 124 – ACCELERATOR CONTROL SYSTEMS **Refer to Vehicle Types, and Applicable “Mobility” Statements that follow**

TYPE 1 The following statement is applicable to all incomplete vehicle types contained in this document and not equipped with a Mobility Package (unless otherwise noted on the cover).

This incomplete vehicle, when completed, will conform to CMVSS 124 and FMVSS 124 providing no alterations are made which affect the function, physical, chemical, or mechanical properties, environment, location or vital spatial clearances of the components, assemblies or systems, as manufactured by General Motors, including but not limited to those listed below:

Accelerator/throttle control systems, including but not limited to:

Attachment pin, hole or ball stud to fuel injection unit throttle lever	Engine controller (controller, software, calibration)
Cable or rod, throttle or accelerator, and support bracket including seals	Floor covering material must not be installed under pedal or within 25.4 mm (1 in) of side of pedal
Cruise control module, wiring and cable (if equipped)	Lever, throttle or accelerator and supporting bracket
Electronic throttle control assembly and related wiring	Pedal-throttle or accelerator and attachments
	Spring(s) - throttle or accelerator return

TYPE 3 The following statement is applicable to all incomplete vehicle types contained in this document and equipped with a Mobility Package (unless otherwise noted on the cover).

Conformity with CMVSS 124 and FMVSS 124 cannot be determined based upon the components supplied on the incomplete vehicle, and General Motors makes no representation to conformity with the standard.

FMVSS 125 – WARNING DEVICES DESIGNED TO BE CARRIED IN MOTOR VEHICLES **Applies to all types of Incomplete Vehicles contained in this Document**

TYPE 1 The following statement is applicable to all types of incomplete vehicles contained in this document if ordered with safety warning triangle option (unless otherwise noted on the cover).

This incomplete vehicle, when completed, will conform to FMVSS 125 providing no alterations are made which affect the function, physical, chemical, or mechanical properties, environment, location or vital spatial clearances of the components, assemblies or systems, as manufactured by General Motors, including but not limited to those listed below:

Safety warning triangles (if equipped)

CMVSS 126 and FMVSS 126 – ELECTRONIC STABILITY CONTROL SYSTEMS **Applies to all types of Incomplete Vehicles Contained in this Document 4536 kg (10,000 lb.) GVWR or less**

TYPE 2 The following statement is applicable to all types of incomplete vehicles contained in this document, 4536 kg (10,000 lb.) GVWR or less (unless otherwise noted on the cover).

This incomplete vehicle when completed will conform to CMVSS 126 and FMVSS 126 provided it is completed in accordance with the following specific conditions by the (intermediate and) final stage manufacturer:

- A. Providing no alterations are made which affect the function, physical, chemical, or mechanical properties, environment, location or vital spatial clearances of the components, assemblies or systems, as manufactured by General Motors, including but not limited to those listed below:
- | | |
|--|---|
| Anti-Lock Brake, Traction Control and Electronic Stability control system, including sensors and control module | Master cylinder-warning statement |
| Brake assemblies and components (service/parking) - (i.e. power boosters, master cylinder, wheel cylinder, calipers, rotors, wheel speed sensor, wheel speed sensor wiring, brake lining etc.) | Owner Manual instructions |
| Brake pedal, brake switch, parking brake hand lever or park brake switch and related mechanical components | Parking brake actuator and related mechanical components |
| Brake system electrical controls and logic | Power steering or vacuum lines and routing |
| Gauges and warning devices, and statements | Power steering or vacuum pump |
| Hydraulic brake fluid and reservoirs | Tires and Wheels |
| Hydraulic brake lines, fittings and routings | Stability control system, including control module, sensors and software calibrations |
| Hydraulic brake valves and components | Steering control system including related hardware |
| | Suspension components (i.e. bushings, control arms, shocks, springs, sway bars) |
| | Vacuum brake lines, fittings and routings |
| | Vehicle wiring harnesses |
| | Wheelbases |
- B. GVWR, GAWR front and rear weight ratings as listed on the Incomplete Vehicle Label affixed to the front cover of this document must not be exceeded.
- C. The Tire Pressures as listed on the Incomplete Vehicle Label affixed to the front cover of this document must be followed
- D. The Maximum Completed Vehicle Unloaded (Curb) restrictions as shown in CMVSS301 and FMVSS 301 Table A, must not be exceeded.
- E. The center of gravity of the total vehicle falls within the areas referenced on the CMVSS 126 and FMVSS 126 Compliance Certification "X = Longitudinal, Y = Lateral and Z = Vertical Center of Gravity (CG) Restrictions" charts that follow. Instructions for determining the allowable center of gravity variation are listed below:

Silverado/Sierra C/K20903 with Z85 suspension, J61 Brake System,
 QXT LT265/70R17 Firestone Transforce AT Tire
 QHQ LT245/75R17 Firestone Transforce HT Tire
 CMVSS 126 and FMVSS 126 Compliance Certification
 "X = Longitudinal, Y = Lateral and Z = Vertical Center of Gravity (CG) Restrictions"

Maximum X Longitudinal CG Location from Front Axle CL cm (in)	Model Identification	Y – Lateral CG Offset Location cm (in)				
		10 (3.9)	5 (2.0)	0	-5 (-2.0)	-10 (-3.9)
160 (63.0)	C/K20903	87.5 (34.4)	92.5 (36.4)	95 (37.4)	92.5 (36.4)	87.5 (34.4)
170 (66.9)	C/K20903	90 (35.4)	95 (37.4)	97.5 (38.4)	95 (37.4)	90 (35.4)
180 (70.9)	C/K20903	90 (35.4)	95 (37.4)	97.5 (38.4)	95 (37.4)	90 (35.4)
190 (74.8)	C/K20903	90 (35.4)	95 (37.4)	97.5 (38.4)	95 (37.4)	90 (35.4)
200 (78.7)	C/K20903	92.5 (36.4)	97.5 (38.4)	100 (39.4)	97.5 (38.4)	92.5 (36.4)
210 (82.7)	C/K20903	92.5 (36.4)	97.5 (38.4)	102.5 (40.4)	97.5 (38.4)	92.5 (36.4)
220 (86.6)	C/K20903	95 (37.4)	100 (39.4)	105 (41.3)	100 (39.4)	95 (37.4)
230 (90.6)	C/K20903	87.5 (34.4)	92.5 (36.4)	97.5 (38.4)	92.5 (36.4)	87.5 (34.4)
		^^^ Maximum Z – Vertical CG Height Restriction Values ^^^ NOTE: Minimum Z – Vertical Height Restriction Value is 30.5 cm (12.0 in) for all models above				

Silverado/Sierra C/K20953 with Z85 suspension, J61 Brake System,
 QXT LT265/70R17 Firestone Transforce AT Tire
 QHQ LT245/75R17 Firestone Transforce HT Tire
 CMVSS 126 and FMVSS 126 Compliance Certification
 "X = Longitudinal, Y = Lateral and Z = Vertical Center of Gravity (CG) Restrictions"

Maximum X Longitudinal CG Location from Front Axle CL cm (in)	Model Identification	Y – Lateral CG Offset Location cm (in)				
		10 (3.9)	5 (2.0)	0	-5 (-2.0)	-10 (-3.9)
190 (74.8)	C/K20953	87.5 (34.4)	92.5 (36.4)	95 (37.4)	92.5 (36.4)	87.5 (34.4)
200 (78.7)	C/K20953	90 (35.4)	95 (37.4)	97.5 (38.4)	95 (37.4)	90 (35.4)
210 (82.7)	C/K20953	90 (35.4)	95 (37.4)	97.5 (38.4)	95 (37.4)	90 (35.4)
220 (86.6)	C/K20953	92.5 (36.4)	97.5 (38.4)	100 (39.4)	97.5 (38.4)	92.5 (36.4)
230 (90.6)	C/K20953	92.5 (36.4)	97.5 (38.4)	100 (39.4)	97.5 (38.4)	92.5 (36.4)
240 (94.5)	C/K20953	92.5 (36.4)	97.5 (38.4)	100 (39.4)	97.5 (38.4)	92.5 (36.4)
250 (98.4)	C/K20953	92.5 (36.4)	97.5 (38.4)	100 (39.4)	97.5 (38.4)	92.5 (36.4)
260 (102.4)	C/K20953	92.5 (36.4)	97.5 (38.4)	100 (39.4)	97.5 (38.4)	92.5 (36.4)
		^^^ Maximum Z – Vertical CG Height Restriction Values ^^^ NOTE: Minimum Z – Vertical Height Restriction Value is 30.5 cm (12.0 in) for all models above				

Silverado/Sierra C/K20943 with Z85 suspension, J61 Brake System,
 QXT LT265/70R17 Firestone Transforce AT Tire
 QHQ LT245/75R17 Firestone Transforce HT Tire
 CMVSS 126 and FMVSS 126 Compliance Certification
 "X = Longitudinal, Y = Lateral and Z = Vertical Center of Gravity (CG) Restrictions"

Maximum X Longitudinal CG Location from Front Axle CL cm (in)	Model Identification	Y – Lateral CG Offset Location cm (in)				
		10 (3.9)	5 (2.0)	0	-5 (-2.0)	-10 (-3.9)
200 (78.7)	C/K20943	90 (35.4)	95 (37.4)	97.5 (38.4)	95 (37.4)	90 (35.4)
210 (82.7)	C/K20943	90 (35.4)	95 (37.4)	97.5 (38.4)	95 (37.4)	90 (35.4)
220 (86.6)	C/K20943	92.5 (36.4)	97.5 (38.4)	100 (39.4)	97.5 (38.4)	92.5 (36.4)
230 (90.6)	C/K20943	95 (37.4)	100 (39.4)	102.5 (40.4)	100 (39.4)	95 (37.4)
240 (94.5)	C/K20943	97.5 (38.4)	102.5 (40.4)	105 (41.3)	102.4 (40.4)	97.5 (38.4)
250 (98.4)	C/K20943	100 (39.4)	105 (41.3)	107.5 (42.3)	105 (41.3)	100 (39.4)
260 (102.4)	C/K20943	100 (39.4)	105 (41.3)	107.5 (42.3)	105 (41.3)	100 (39.4)
270 (106.3)	C/K20943	97.5 (38.4)	102.5 (40.4)	105 (41.3)	102.4 (40.4)	97.5 (38.4)
		^^^ Maximum Z – Vertical CG Height Restriction Values ^^^ NOTE: Minimum Z – Vertical Height Restriction Value is 30.5 cm (12.0 in) for all models above				

Silverado/Sierra C/K10903 with Z85 suspension, J61 Brake System,
 RC5 LT265/70R17 Bridgestone Dueler A/T Tire
 CMVSS 126 and FMVSS 126 Compliance Certification
 "X = Longitudinal, Y = Lateral and Z = Vertical Center of Gravity (CG) Restrictions"

Maximum X Longitudinal CG Location from Front Axle CL cm (in)	Model Identification	Y – Lateral CG Offset Location cm (in)				
		10 (3.9)	5 (2.0)	0	-5 (-2.0)	-10 (-3.9)
130 (51.2)	C/K10903	75.0 (29.5)	77.5 (30.5)	85.0 (33.5)	77.5 (30.5)	75.0 (29.5)
140 (55.1)	C/K10903	77.5 (30.5)	80.0 (31.5)	87.5 (34.5)	80.0 (31.5)	77.5 (30.5)
150 (59.1)	C/K10903	80.0 (31.5)	85.0 (33.5)	90.0 (35.4)	85.0 (33.5)	80.0 (31.5)
160 (63.0)	C/K10903	82.5 (32.5)	87.5 (34.5)	90.0 (35.4)	87.5 (34.5)	82.5 (32.5)
170 (66.9)	C/K10903	85.0 (33.5)	90.0 (35.4)	92.5 (36.4)	90.0 (35.4)	85.0 (33.5)
180 (70.9)	C/K10903	85.0 (33.5)	90.0 (35.4)	92.5 (36.4)	90.0 (35.4)	85.0 (33.5)
190 (74.8)	C/K10903	85.0 (33.5)	90.0 (35.4)	92.5 (36.4)	90.0 (35.4)	85.0 (33.5)
200 (78.7)	C/K10903	85.0 (33.5)	90.0 (35.4)	92.5 (36.4)	90.0 (35.4)	85.0 (33.5)
210 (82.7)	C/K10903	85.0 (33.5)	90.0 (35.4)	92.5 (36.4)	90.0 (35.4)	85.0 (33.5)
220 (86.6)	C/K10903	85.0 (33.5)	87.5 (34.5)	92.5 (36.4)	87.5 (34.5)	85.0 (33.5)
		^^^ Maximum Z – Vertical CG Height Restriction Values ^^^ NOTE: Minimum Z – Vertical Height Restriction Value is 30.5 cm (12.0 in) for all models above				

**CMVSS 126 and FMVSS 126 Compliance Certification
Y = Lateral and Z = Vertical Center of Gravity Restriction
Visual Representation EXAMPLE shown in centimeters**

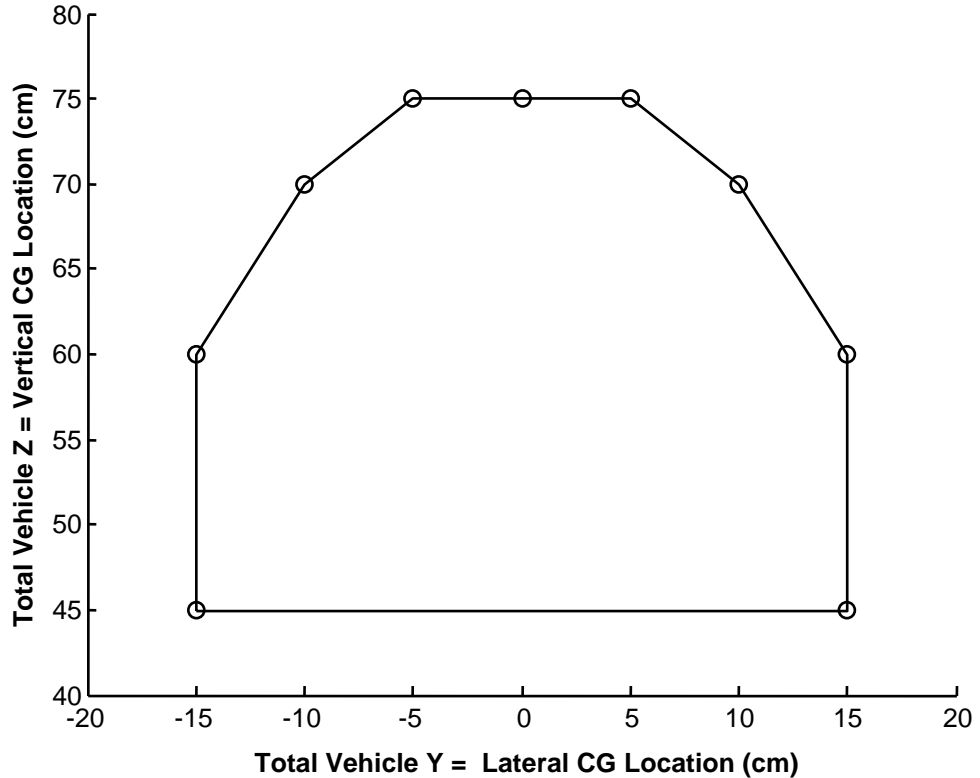

For upfitter use and applicable to CMVSS 126 and FMVSS 126, the longitudinal and vertical vehicle center of gravity location can be approximated by following the formula below and by referencing data elements within CMVSS 105 and FMVSS 105 – HYDRAULIC AND ELECTRIC BRAKE SYSTEMS or CMVSS 135 and FMVSS 135 LIGHT VEHICLE BRAKE SYSTEMS, ... ALLOWABLE CENTER OF GRAVITY CHARTS.

$$d = \frac{[W_{rc} + W_{rb}] WB}{W_t}$$

$$h = \frac{[h_1 * W_c + h_2 * W_b]}{W_t}$$

d = horizontal distance from front wheels to completed vehicle center of gravity cm (in)

h = vertical distance from ground to completed vehicle center of gravity cm (in)

W_{rc} = rear component of Chassis weight kg (lb.)

W_{rb} = rear component of body weight kg (lb.)

WB = vehicle wheelbase cm (in)

W_t = total weight of chassis and body kg (lb.)

h₁ = center of gravity height from ground of the Bare Chassis:

Based on model applicability, refer to the h₁ values listed in this document within:

CMVSS 105/FMVSS 105 - HYDRAULIC AND ELECTRIC BRAKE SYSTEMS, or CMVSS 135/FMVSS 135 - LIGHT VEHICLE BRAKE SYSTEMS.

W_c = total weight of vehicle as manufactured by General Motors kg (lb.)

h₂ = center of gravity height of body from ground cm (in)

W_b = total weight of body kg (lb.)

In addition, the equation to calculate the lateral vehicle center of gravity location from center of vehicle can be estimated by using the following formula:

$$\text{lateral offset from centerline of vehicle} = [((\text{RF corner weight kg (lb.)} + \text{RR corner weight kg (lb.)}) / (\text{total vehicle weight kg (lb.)}) - 0.5) * \text{vehicle track width of 1738 mm (68.4 in)}]$$

If the lateral offset from centerline of vehicle calculation above results in a positive number, the lateral vehicle offset center of gravity is toward the right side (passenger) of the vehicle.

Alternatively, if the lateral offset from centerline of vehicle calculation above results in a negative number, the lateral vehicle offset center of gravity is toward the left side (driver) of the vehicle.

FMVSS 127 – AUTOMATIC EMERGENCY BRAKING SYSTEMS FOR LIGHT VEHICLES
Applies to all types of Incomplete Vehicles Contained in this Document
4536 kg (10,000 lb) GVWR or less

TYPE 3 The following statement is applicable to all types of incomplete vehicles contained in this document, with a 4536 kg (10,000 lb) GVWR or less.

Conformity with FMVSS 127 cannot be determined based upon the components supplied on the incomplete vehicle, and General Motors makes no representation to conformity with the standard.

CMVSS 135 and FMVSS 135 – LIGHT VEHICLE BRAKE SYSTEMS
Applies to all types of Incomplete Vehicles contained in this document
3500 kg (7,716 lb.) GVWR or less

TYPE 2 The following statement is applicable to all types of Incomplete Vehicles contained in this document with a 3500 kg (7,716 lb.) GVWR or less, (unless otherwise noted on the cover).

This incomplete vehicle when completed will conform to CMVSS 135 and FMVSS 135 provided it is completed in accordance with the following specific conditions by the (intermediate and) final stage manufacturer:

- A. Providing no alterations are made which affect the function, physical, chemical, or mechanical properties, environment, location or vital spatial clearances of the components, assemblies or systems, as manufactured by General Motors, including but not limited to those listed below (if equipped):
- | | |
|---|---|
| Anti-Lock Brake System | Hydraulic brake lines, fittings and routings |
| Brake assemblies and components (service/ parking) - (i.e. power boosters, master cylinder, wheel cylinder, calipers, rotors, wheel speed sensor, wheel speed sensor wiring, brake lining etc.) | Hydraulic brake hoses and mounting brackets |
| Brake pedal, brake switch, parking brake pedal or park brake switch and related mechanical components | Hydraulic brake valves and components |
| Brake system electrical controls and logic | Master cylinder-warning statement |
| Gauges and warning devices, and statements | Owner Manual instructions |
| Hydraulic brake fluid and reservoirs | Parking brake actuator and related mechanical components |
| | Power steering or vacuum lines and routing |
| | Power steering or vacuum pump |
| | Shocks, springs and other suspension components |
| | Tires and Wheels |
| | Vacuum brake lines, fittings and routings |
| | Vehicle wiring harnesses |
| | Electric parking brake and wheel speed sensor wiring harness, attaching brackets, and mounting hardware |
| | Wheelbases |
- B. GVWR, GAWR front and rear weight ratings as listed on the Incomplete Vehicle Label affixed to the front cover of this document must not be exceeded.

- C. The center of gravity of the total vehicle falls within the areas referenced on the “ALLOWABLE CENTER OF GRAVITY CHART” that follows. Instructions for determining the allowable center of gravity variation are listed below:

These charts detail the envelope of allowable center of gravity variation for completed vehicles. This is significant for the lightly loaded portion of CMVSS 135 and FMVSS 135, which is defined as curb plus 181.4 kg (400 lb.) distributed in the driver-passenger area of the vehicle.

The lightly loaded center of gravity of complete vehicles needs to be restricted so it will meet CMVSS 135 and FMVSS 135 stopping distances. The laden center of gravity does not need to be specified as it is controlled within the CMVSS 135 and FMVSS 135 test procedure by specific instructions as to how ballast is to be placed (while height is not controlled, it is assumed that for test purposes it would be reasonable).

For upfitter use, the center of gravity location can be approximated by the following formula:

$$d = \frac{[Wrc + Wrb + [(Hp)(Wp)/WB]] WB}{Wt}$$

$$h = \frac{[h1Wc + h2Wb + (h3)(Wp)]}{Wt}$$

- d = horizontal distance from front wheels to completed vehicle center of gravity mm (in)
h = vertical distance from ground to completed vehicle center of gravity mm (in)
Wrc = rear component of Chassis weight kg (lb.)
Wrb = rear component of body weight kg (lb.)
WB = vehicle wheelbase mm (in)
Wt = total weight of chassis and body kg (lb.) plus 181.4 kg (400 lb.)
h1 = center of gravity height from ground of the Bare Chassis = 761 mm (30 in)
Wc = total weight of Chassis kg (lb.)
h2 = center of gravity height of body from ground mm (in)
Wb = total weight of body kg (lb.)
Wp = 181.4 kg (400 lb.) Amount from lightly loaded definition that is evenly distributed in driver-passenger area of vehicle.
Hp = 1493 mm (58.78 in) Horizontal distance from front axle to center of gravity of 181.4 kg (400 lb.) evenly distributed in driver-passenger area of vehicle.
h3 for Pickup = 995 mm (39.17 in) Vertical center of gravity height of 181.4 kg (400 lb.) evenly distributed in driver-passenger area for vehicles with 3500 kg (7,716 lb.) GVWR or less.
h3 for Utility = 945 mm (37.2 in) Vertical center of gravity height of 181.4kg (400 lb) evenly distributed in driver-passenger area for vehicles with 3500 kg (7,716 lb) GVWR or less.

CMVSS 135 and FMVSS 135 ALLOWABLE CENTER OF GRAVITY CHART

Model	GVWR kg (lb)	Brake System	Wheel- base mm (in)	Vehicle	Incomplete SUV or Pick-Up Box Removal							
					Coordinates of Allowable C/G Variation at CMVSS / FMVSS Unladen, Curb Weight + 181.4 kg (400 lb.) mm (in)							
					Trapezoid Coordinates mm (in)						Fwd C/G Limit mm (in)	RRwd C/G Limit mm (in)
					H ₁	H ₂	A	B	C	D	E	F
C10706	3357 (7400)	J55	3071 (120.9)	Utility	304.8 (12.0)	1219.2 (48.0)	869 (34.2)	1409 (55.5)	1885 (74.2)	2140 (84.3)	1351 (53.2)	1833 (72.2)
K10706	3447 (7600)	J55	3071 (120.9)	Utility	304.8 (12.0)	1219.2 (48.0)	869 (34.2)	1409 (55.5)	1885 (74.2)	2139 (84.2)	1351 (53.2)	1833 (72.2)
K10706	3447 (7600)	J61	3071 (120.9)	Utility	304.8 (12.0)	1219.2 (48.0)	834 (32.8)	1374 (54.1)	1838 (72.4)	2093 (82.4)	1351 (53.2)	1809 (71.2)
C10903	3084 (6800)	J61	3545 (139.6)	Pickup	304.8 (12.0)	1219.2 (48.0)	954 (37.6)	1494 (58.8)	2144 (84.4)	2398 (94.4)	1241 (48.8)	2015 (79.3)
K10903	3130 (6900)	J61	3545 (139.6)	Pickup	304.8 (12.0)	1219.2 (48.0)	954 (37.6)	1494 (58.8)	2144 (84.4)	2398 (94.4)	1241 (48.8)	2015 (79.3)

ABS = Antilock Braking System
 Brake Systems: J61 Brake System Power ,Frt & Rr Disc, ABS, 17"
 C/G = Center of Gravity

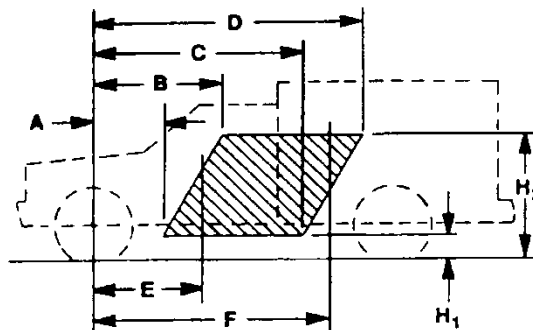

C/G of vehicle in CMVSS or FMVSS unladen condition [Curb + 181.4 kg. (400 lb.)] must be inside shaded area – that is, the C/G must be within the trapezoid formed by the coordinates A, B, C, D, H1, & H2, plus the C/G must be to the rear of vertical line E and forward of vertical line F.

FMVSS 138 – TIRE PRESSURE MONITORING SYSTEMS (If Equipped) **Applies to all types of Incomplete Vehicles Contained in this Document** **4536 kg (10,000 lb.) GVWR or less**

TYPE 2 The following statement is applicable to all types of incomplete vehicles contained in this document (unless otherwise noted on the cover).

This incomplete vehicle, when completed, will conform to FMVSS 138, providing the vehicle is equipped with a Tire Pressure Monitoring System (TPMS) installed by General Motors, and no alterations are made which affect the function, physical, chemical, or mechanical properties, environment, location or vital spatial clearances of

the components, assemblies or systems, as manufactured by General Motors, including but not limited to those listed below (if equipped):

Body control module	Tires and Wheels
Instrument panel cluster	TPMS receiver module
Owner Manual instructions	TPMS sensors integral to the valve stems
Remote start coax antennae (if equipped)	Vehicle wiring harness

All incomplete vehicles shipped from the General Motors assembly plant will have tire pressures set for shipping purposes only. It is responsibility of the final stage manufacturer to label the vehicle in compliance to FMVSS 138. In addition, it is the responsibility of the final stage manufacturer to ensure the TPMS system is calibrated to the values printed on the final stage manufacturer's Tire Certification Label or Tire Information Label.

Wheelbase alteration, and/or addition of components may interfere with the TPMS radio frequency signal that may result in a malfunction warning displayed in the Driver Information Center (DIC). **If this condition is observed, go to the GM Upfitter Integration website located at www.gmupfitter.com**

NOTE: The TPMS is not required to monitor the spare tire, either when it is stowed or when it is installed on the vehicle.

CMVSS 201 and FMVSS 201 – OCCUPANT PROTECTION IN INTERIOR IMPACT
Applies to all types of Incomplete Vehicles Contained in this Document
4536 kg (10,000 lb.) GVWR or less

TYPE 1 The following statement is applicable to all types of incomplete vehicles contained in this document, 4536 kg (10,000 lb.) GVWR or less (unless otherwise noted on the cover).

This incomplete vehicle, when completed, will conform to CMVSS 201 and FMVSS 201 providing no alterations are made which affect the function, physical, chemical, or mechanical properties, environment, location or vital spatial clearances of the components, assemblies or systems, as manufactured by General Motors, including but not limited to those listed below:

A, B, C pillar structure	Interior compartment doors
Air bag system	Roof structure
Armrests, folding and stationary	Seat adjusters
Assist handles	Seats, seat backs and head restraints
Body structure	Seat air bag
Door pads	Sensing diagnostic module (SDM)
Door structure	Sunvisors
Headliner	Upper interior trim
Instrument panel	

CMVSS 201 and FMVSS 201 – OCCUPANT PROTECTION IN INTERIOR IMPACT
Applies to all types of Incomplete Vehicles Contained in this Document
4536 kg (10,000 lb.) GVWR or less

TYPE 3 The following statement is applicable to any type of incomplete vehicle contained in this document, 4536 kg (10,000 lb.) GVWR or less, with any seat delete option that is applicable to any seating position (unless otherwise noted on the cover).

Conformity with CMVSS 201 and FMVSS 201 cannot be determined based upon the components supplied on the incomplete vehicle, and General Motors makes no representation to conformity with the standard.

NOTE: Any seats installed by intermediate or final stage manufacturers must comply with CMVSS 201 and FMVSS 201. In addition, the "H" point of any seats installed by the intermediate or final stage manufacturers must be located as shown in the **GM Upfitter Integration website located at www.gmupfitter.com**

This incomplete vehicle, when completed, will conform to CMVSS 204 and FMVSS 204 providing the dimension and mass as well as other restrictions found in MVSS 301 Table A, are not exceeded, and no alterations are made which affect the function, physical, chemical, or mechanical properties, environment, location or vital spatial clearances of the components, assemblies or systems, as manufactured by General Motors, including but not limited to those listed below that would affect the steering control system displacement in a 48 kph (30 mph) fixed barrier impact:

Frame assembly and mounting system	Steering wheel, column, and shaft assembly
Front impact bar assembly and mounting system	Tires and wheels
Hood and hinge assemblies	Vehicle/body front end sheet metal components
Powertrain and powertrain mounting system	Vehicle/body front end structural components
Steering control system including related hardware	Vehicle/body roof structure and components

TYPE 3 The following statement is applicable to any type of incomplete vehicle contained in this document, 4536 kg (10,000 lb.) GVWR or less, with any bumper delete option (unless otherwise noted on the cover).

Conformity with CMVSS 204 and FMVSS 204 cannot be determined based upon the components supplied on the incomplete vehicle, and General Motors makes no representation to conformity with the standard.

CMVSS 205 and FMVSS 205 – GLAZING MATERIALS **Applies to all types of Incomplete Vehicles contained in this Document**

TYPE 1 The following statement is applicable to all types of incomplete vehicles contained in this document (unless otherwise noted on the cover).

This incomplete vehicle, when completed, will conform to CMVSS 205 and FMVSS 205 providing no alterations are made which affect the function, physical, chemical, or mechanical properties, environment, location or vital spatial clearances of the components, assemblies or systems, as manufactured by General Motors, including but not limited to those listed below:

Glazing material	Visibility of the monogram
Monogram	Windshield shade banding

Final compliance with CMVSS 205 and FMVSS 205 is the responsibility of the final stage manufacturer for any modifications, or added material, parts, components, or systems.

CMVSS 206 and FMVSS 206 – DOOR LOCKS AND DOOR RETENTION COMPONENTS **Applies to all types of Incomplete Vehicles Contained in this Document**

TYPE 1 The following statement is applicable to all types of incomplete vehicles contained in this document (unless otherwise noted on the cover).

This incomplete vehicle, when completed, will conform to CMVSS 206 and FMVSS 206 providing no alterations are made which affect the function, physical, chemical, or mechanical properties, environment, location or vital spatial clearances of the components, assemblies or systems, as manufactured by General Motors, including but not limited to those listed below:

Door and pillar systems, including but not limited to:

Body rear end upper and lower panel	Doors
Door hinges	Exterior door handles
Door latch strikers and striker plates	Inside lock control linkages
Door latches	Rear compartment latch and striker assembly
Door locks	Rear compartment lid assembly
Door pillars	Rear compartment lid hinge assembly
Door wedges	

Final compliance with CMVSS 206 and FMVSS 206 is the responsibility of the final stage manufacturer for any modifications, or added material, parts, components, or systems.

TYPE 3 The following statement is applicable to any type of incomplete vehicle contained in this document, with a rear door inside door handle inoperative option (unless otherwise noted on the cover).

Conformity with CMVSS 206 and FMVSS 206 cannot be determined based upon the components supplied on the incomplete vehicle, and General Motors makes no representation to conformity with the standard.

CMVSS 207 and FMVSS 207 – SEATING SYSTEMS **Applies to all types of Incomplete Vehicles Contained in this Document**

TYPE 1 The following statement is applicable to all types of incomplete vehicles contained in this document (unless otherwise noted on the cover).

This incomplete vehicle, when completed, will conform to CMVSS 207 and FMVSS 207 providing no alterations are made which affect the function, physical, chemical, or mechanical properties, environment, location or vital spatial clearances of the components, assemblies or systems, as manufactured by General Motors, including but not limited to those listed below:

Floor pan assemblies	Seat assembly
Folding seat or seat back latch assembly	Seat or seat back latch assembly
Seat adjuster assembly	Seat or seat back latch release control
Seat anchorage brackets, reinforcements, attachment hardware, etc.	Seat or seat back latch striker
	Seat riser

TYPE 3 The following statement is applicable to any type of incomplete vehicle contained in this document, with any seat delete option that is applicable to any seating position (unless otherwise noted on the cover).

Conformity with CMVSS 207 and FMVSS 207 cannot be determined based upon the components supplied on the incomplete vehicle, and General Motors makes no representation to conformity with the standard.

CMVSS 208 and FMVSS 208 – OCCUPANT CRASH PROTECTION **Applies to all types of Incomplete Vehicles Contained in this Document**

TYPE 1 The following statement is applicable to all types of vehicles contained in this document (unless otherwise noted on the cover) having an unloaded vehicle weight of 2495 kg (5,500 lb.) or less and a GVWR of 3856 kg (8,500 lb.) or less, and built by General Motors with complete seats and seat belt assemblies.

A. The front seating positions provided by General Motors will conform to the requirements of CMVSS 208 and FMVSS 208, providing the dimension and mass as well as other restrictions (excluding the Maximum Frontal Area) found in MVSS 301 Table A, are not exceeded, and no alterations are made which affect the function, physical, chemical, or mechanical properties, environment, location or vital spatial clearances of the components, assemblies or systems, as manufactured by General Motors, including but not limited to those listed below:

1. The number, location or configuration of the designated seating positions including seats, risers, adjusters.
2. The number, placement, installation or model number of the seat belt assemblies provided.
3. The Owner Manual instructions, the instrument panel or its mounting, the steering column/shaft or its mounting, the knee bolster or its mounting, the steering wheel, horn pad, driver air bag module or its mounting and covering, passenger air bag module or its mounting or covering (if equipped), air bag crash sensors, windshield, or interior trim. Note: For the "Passenger Sensing System" (if equipped), modifying or putting a padded cover on the passenger seat can affect the performance of this system.

4. Sensing and Diagnostic Module (SDM), and all air bag system wiring. Do not relocate or move the SDM, or air bag crash sensors. Do not obstruct the path of air bag deployment. Do not mount any components that produce more than a 20 Gauss magnetic field as measured at the SDM. Speakers/*magnets* must be located at least 12.7 cm (5 in) from the SDM. You must disconnect the SDM before doing any welding on the vehicle, otherwise do not disconnect the SDM. **Caution: To help avoid Personal Injury Due to unwanted air bag inflation, observe the following precautions!** Do not weld, solder, braze, hammer, machine, drill, heat, electrical splice, add onto, remove, relocate, test, paint, loosen or in any way alter air bag components or wiring or fuses. Carpet may be put over the SDM if an appropriate moisture barrier (such as a rubber-matted backing) is supplied. When performing any operation around air bag components or wiring, including but not limited to any operations around the instrument panel, electrical wiring and fuse block, steering column/wheel, and the engine compartment, you must disable the air bag system prior to the operation. If the vehicle is equipped with an SDM, you must disable the air bag system prior to installing intermediate or final stage manufacturer components. *Note: Striking or dropping a powered SDM may cause air bag deployment.* The air bag system must be enabled after operation completion. This must be verified before shipping the vehicle. Instructions for disabling and enabling the air bag system can be found in the GM service manual. **Note: All connectors that have wiring routed between the SDM and an air bag inflator module have yellow connectors.**
 5. If the sunvisor is removed or altered, or if the intermediate or final stage manufacturer installs the sunvisor, a new Inflatable Restraints System Caution label must be installed per CMVSS 208 and FMVSS 208 requirements. In order to be in compliance with CMVSS 208 and FMVSS 208, no other label shall be installed on the same side of the sunvisor as the Air Bag Caution label. The instrument panel temporary warning label (if equipped) must not be removed.
 6. The vehicle frame, front bumper system, body structure including front sheet metal or other front structure, roof structure, doors, floor pan, dash panel, cowl structure, rocker structure, driveline or contents of the engine compartment by any incomplete or final stage manufacturer which would result in any difference from the modified vehicle's deceleration if the modified vehicle were to be subjected to barrier impact tests conducted per CMVSS 208 and FMVSS 208.
- B. The rear seating positions provided by General Motors will conform to CMVSS 208 and FMVSS 208 providing no alterations are made to the number, location or configuration of the designated seats/seating positions or to the number, placement, installation or model number of the seat belt assemblies of this incomplete vehicle.
- C. Intermediate or final stage manufacturers are advised that mounting hardware ahead of the bumper/radiator, such as, but not limited to, plows, winches, brush guards, etc., may affect airbag sensing and resultant performance.

TYPE 2 The following statement is applicable to all types of vehicles contained in this document (unless otherwise noted on the cover) having either an unloaded vehicle weight greater than 2495 kg (5,500 lb.) or a GVWR greater than 3856 kg (8,500 lb.), and built by General Motors with complete seats and seat belt assemblies.

This incomplete vehicle, when completed, will conform to CMVSS 208 and FMVSS 208 providing no alterations are made which affect the function, physical, chemical, or mechanical properties, environment, location or vital spatial clearances of the components, assemblies or systems, as manufactured by General Motors, including but not limited to those listed below:

- | | |
|---------------------------|--------------------------|
| Owner Manual instructions | Seat belt anchorages |
| Seat anchorages | Seat belt assemblies |
| Seat assemblies | Seat belt warning system |

TYPE 3 The following statement is applicable to all types of incomplete vehicles contained in this document with respect to any seats, seat belt assemblies or seat belt assembly anchorages installed by the intermediate or final stage manufacturer (unless otherwise noted on the cover).

Conformity with CMVSS 208 and FMVSS 208 cannot be determined based upon the components supplied on the incomplete vehicle, and General Motors makes no representation to conformity with the standard.

CMVSS 209 and FMVSS 209 – SEAT BELT ASSEMBLIES
Applies to all types of Incomplete Vehicles Contained in this Document

TYPE 1 The following statement is applicable to all types of incomplete vehicles contained in this document (unless otherwise noted on the cover).

The seat belt assembly provided by General Motors when mounted to its original attachments locations, at any designated seating position, will conform to CMVSS 209 and FMVSS 209 providing no alterations are made which affect the function, physical, chemical, or mechanical properties, environment, location or vital spatial clearances of the components, assemblies or systems, as manufactured by General Motors, including but not limited to those listed below:

Owner Manual instructions	Seat belt anchorages
Seat anchorages	Seat belt assemblies
Seat assemblies	

TYPE 3 The following statement is applicable to all types of incomplete vehicles contained in this document with respect to any seats, seat belt assemblies or seat belt assembly anchorages installed by the intermediate or final stage manufacturer (unless otherwise noted on the cover).

Conformity with CMVSS 209 and FMVSS 209 cannot be determined based upon the components supplied on the incomplete vehicle, and General Motors makes no representation to conformity with the standard.

CMVSS 210 and FMVSS 210 – SEAT BELT ASSEMBLY ANCHORAGES
Applies to all types of Incomplete Vehicles Contained in this Document

TYPE 1 The following statement is applicable to all types of incomplete vehicles contained in this document (unless otherwise noted on the cover).

This incomplete vehicle, when completed, will conform to CMVSS 210 and FMVSS 210 providing no alterations are made which affect the function, physical, chemical, or mechanical properties, environment, location or vital spatial clearances of the components, assemblies or systems, as manufactured by General Motors, including but not limited to those listed below:

B, C, and D-pillar structures	Seat assemblies
Child restraint system including lower and top tether anchorages, seat brackets, plates and reinforcements	Seat belt assemblies
Floor pan assembly	Seat belt anchorage brackets, plates, and reinforcements
Owner Manual instructions	Seat belt routing
Roof structure	Seat position/adjustment capability

TYPE 3 The following statement is applicable to all types of incomplete vehicles contained in this document with seat or seat belt delete options in any seating position (unless otherwise noted on the cover).

Conformity with CMVSS 210 and FMVSS 210 cannot be determined based upon the components supplied on the incomplete vehicle, and General Motors makes no representation to conformity with the standard.

CMVSS 210.1 – TETHER ANCHORAGES FOR RESTRAINT SYSTEMS
Applies to all types of Incomplete Vehicles Contained in this Document to be completed as a Multipurpose Passenger Vehicle or Truck with a 3856 kg (8,500 lb.) GVWR or less and an Unloaded Vehicle Weight of 2495 kg (5,500 lb.) or less

TYPE 1 The following statement is applicable to all multipurpose passenger vehicle or truck types of incomplete vehicles contained in this document with a 3856 kg (8500 lb.) GVWR or less and an Unloaded Vehicle Weight of 2495 kg (5,500 lb.) or less (unless otherwise noted on the cover).

This incomplete vehicle, when completed, will conform to CMVSS 210.1 provided the original equipment seats are not replaced, no seating positions are removed or added, and no alterations are made which affect the function, physical, chemical, or mechanical properties, environment, location or vital spatial clearances of the components, assemblies or systems, as manufactured by General Motors, including but not limited to those listed below:

Child restraint system including lower and top tether anchorages, seat brackets, plates and reinforcements	Owner Manual instructions Seat assemblies Seat belt assemblies
Access to lower anchorage system	Seat belt anchorage brackets, plates, and reinforcements
Floor pan assembly	Seat belt routing
Head restraints / head rest	Seat position/adjustment capability
Labeling requirements	

TYPE 3 The following statement is applicable to all types of incomplete vehicles contained in this document with seat or seat belt delete options in any seating position (unless otherwise noted on the cover).

Conformity with CMVSS 210.1 cannot be determined based upon the components supplied on the incomplete vehicle, and General Motors makes no representation to conformity with the standard.

**CMVSS 210.2 – LOWER UNIVERSAL ANCHORAGE SYSTEMS
FOR RESTRAINT SYSTEMS AND BOOSTER CUSHIONS**
Applies to all types of Incomplete Vehicles Contained in this Document
with a 3856 kg (8,500 lb.) GVWR or less
and an Unloaded Vehicle Weight of 2495 kg (5,500 lb.) or less

TYPE 1 The following statement is applicable to all types of incomplete vehicles contained in this document (unless otherwise noted on the cover).

This incomplete vehicle, when completed, will conform to CMVSS 210.2 provided the original equipment seats are not replaced, no seating positions are removed or added, and no alterations are made which affect the function, physical, chemical, or mechanical properties, environment, location or vital spatial clearances of the components, assemblies or systems, as manufactured by General Motors, including but not limited to those listed below:

Airbag manual cut-off switch (if equipped)	Owner Manual instructions
Child restraint system including lower and top tether anchorages, seat brackets, plates and reinforcements	Seat assemblies Seat belt assemblies
Access to lower anchorage system	Seat belt anchorage brackets, plates, and reinforcements
Floor pan assembly	Seat belt routing
Labeling requirements	Seat position/adjustment capability

TYPE 3 The following statement is applicable to all types of incomplete vehicles contained in this document with seat or seat belt delete options in any seating position (unless otherwise noted on the cover).

Conformity with CMVSS 210.2 cannot be determined based upon the components supplied on the incomplete vehicle, and General Motors makes no representation to conformity with the standard.

CMVSS 212 and FMVSS 212 – WINDSHIELD MOUNTING
Applies to all types of Incomplete Vehicles Contained in this Document
4536 kg (10,000 lb.) GVWR or less

TYPE 2 The following statement is applicable to all types of incomplete vehicles contained in this document (unless otherwise noted on the cover) with a 4536 kg (10,000 lb.) GVWR or less, when completed will conform to CMVSS 212 and FMVSS 212 if:

- A. No alterations are made which affect the function, physical, chemical, or mechanical properties, environment, location or vital spatial clearances of the components, assemblies or systems, as manufactured by General Motors, including but not limited to those listed below:

Airbag crash sensors	Seat belt assemblies
Airbag system including covers and module	Sensing and Diagnostic Module (SDM) and retainers/brackets
Airbag system wiring harnesses, connectors, and fuses/relays	Steering control system including related hardware
Dash panel and cowl assembly	Steering wheel, column, and shaft assembly
Doors and hinge assemblies	Sunvisor assemblies
Frame assembly and mounting system	Vehicle/body front sheet metal components/reinforcements
Front impact bar assembly and mounting system	Vehicle/body front structural components/reinforcements
Hood and hinge assemblies	Vehicle/body roof structure and components
Powertrain and powertrain mounting system	Windshield and windshield mounting system
Seat anchorages	Windshield frame/frame reinforcement
Seat assemblies	
Seat belt anchorages	

During a 48 kph (30 mph) frontal barrier impact test, no component installed by any intermediate or final stage manufacturer shall move forward from its permanently mounted position.

- B. The following statements apply to only Chassis Cab and Pick-up types of incomplete vehicles:

1. The dimension and mass as well as other restrictions found in MVSS 301 Table A, are not exceeded.
2. The minimum vertical clearance between the cab roof and any portion of the installed body or accessories that extends over the cab roof must not be less than 20 cm (8 in).

CMVSS 213.4 and FMVSS 213 – BUILT-IN CHILD RESTRAINT SYSTEMS AND BUILT-IN BOOSTER CUSHIONS

Applies to all types of Incomplete Vehicles contained in this Document

TYPE 3 The following statement is applicable to all types of incomplete vehicles contained in this document (unless otherwise noted on the cover).

Conformity with CMVSS 213.4 and FMVSS 213 cannot be determined based upon the components supplied on the incomplete vehicle, and General Motors makes no representation to conformity with the standard.

CMVSS 214 and FMVSS 214 – SIDE IMPACT PROTECTION

Applies to all types of Incomplete Vehicles contained in this Document

4536 kg (10,000 lb.) GVWR or less – Quasi-static side door crush resistance and Dynamic Oblique Side Pole Impact

TYPE 2 The following statement is applicable to all types of incomplete vehicles contained in this document with a GVWR greater than 2,722 kg (6,000 lb) and less than or equal to 4536 kg (10,000 lb.) (unless otherwise noted on the cover).

This incomplete vehicle, when completed, will conform to CMVSS 214 and FMVSS 214 providing:

- A. No alterations are made which affect the function, physical, chemical, or mechanical properties, environment, location or vital spatial clearances of the components, assemblies or systems, as manufactured by General Motors, including but not limited to those listed below:

Airbag crash sensors	Front door trim panels
Airbag system including covers and module	Front and rear door wedges
Airbag system wiring harnesses, connectors, and fuses/relays	Front and rear door window mechanisms
Body structure including roof structure and components	Front seat air bags
	Front seat anchorages
	Front seat assemblies

Body sheet metal components/reinforcements	Front seat belt anchorages
Front and rear door assemblies	Front seat belt assemblies
Front and rear door hinges	Sensing and Diagnostic Module (SDM) and retainers/brackets
Front and rear door latch mechanisms	Side curtain airbag system
Front and rear door latch	Tires and Wheels
strikers and striker plates	Upper interior trim including headliner
Front and rear door latches	Vehicle frame
Front and rear door pillars	

B. The (intermediate and) final stage manufacturer conforms to the following:

1. a box, platform, or other rear structural assembly must be installed on the back of the vehicle.
2. the rear assembly structure must provide comparable stiffness to the pickup box sold as original equipment as part of the complete vehicle version of this product.
3. the method of rear assembly structure mounting and mount properties (material and structural) are similar to those used to attach the pickup box sold as original equipment as part of the complete vehicle version of this product.
4. the dimension and mass as well as other restrictions found in MVSS 301 Table A, are not exceeded.

CMVSS 216 and FMVSS 216a – ROOF CRUSH RESISTANCE
Pick-ups and Chassis Cabs with a GVWR of 4536 kg (10,000 lb.) or less

TYPE 2 The following statement is applicable to Pick-ups or Chassis Cabs with a GVWR of 4536 kg (10,000 lb.) or less contained in this document (unless otherwise noted on the cover).

This incomplete vehicle, when completed, will conform to CMVSS 216 and FMVSS 216a if:

A. No alterations are made which affect the function, physical, chemical, or mechanical properties, environment, location or vital spatial clearances of the components, assemblies or systems, as manufactured by General Motors, including but not limited to those listed below:

Doors and hinge assemblies	Vehicle/body roof structure and components
Frame assembly and mounting system	Windshield and windshield mounting system
Roof rail air bags	Windshield frame/frame reinforcement
Vehicle A, B and C pillar structure	All other window frame and glazing material.
Vehicle/body front structural components/reinforcements	Sun roof (if equipped)

B. The unloaded vehicle weight of the completed vehicle does not exceed the values below for:

Regular cab:	3,856 kg (8,500 lbs.)
Double cab:	3,856 kg (8,500 lbs.)
Crew cab:	3,856 kg (8,500 lbs.)
Utility Vehicle:	2,681 kg (5,911 lbs.)

CMVSS 219 and FMVSS 219 – WINDSHIELD ZONE INTRUSION
Applies to all types of Incomplete Vehicles contained in this Document
4536 kg (10,000 lb.) GVWR or less

TYPE 2 The following statement is applicable to all types of incomplete vehicles contained in this document with a 4536 kg (10,000 lb.) GVWR or less (unless otherwise noted on the cover).

This incomplete vehicle, when completed, will conform to CMVSS 219 and FMVSS 219 providing:

A. No alterations are made which affect the function, physical, chemical, or mechanical properties, environment, location or vital spatial clearances of the components, assemblies or systems, as manufactured by General Motors, including but not limited to those listed below:

Antennae	Hood assembly
Body roof structure and components/ reinforcements	Hood mounts
Body sheet metal components/reinforcements	Motor compartment structure and components
Body structural components/reinforcements	Windshield wiper
Dash panel and cowl structure	Windshield wiper motor

- B. The dimension and mass as well as other restrictions (excluding the Maximum Frontal Area) found in MVSS 301 Table A, are not exceeded.
- C. During a 48 kph (30 mph) frontal barrier impact test:
1. no component installed by any intermediate or final stage manufacturer shall prevent the hood from folding in its designed folding pattern; and
 2. no component installed by any intermediate or final stage manufacturer shall penetrate the windshield or protected zone.

CMVSS 220 and FMVSS 220 – SCHOOL BUS ROLLOVER PROTECTION
For all models using as an Alternative Compliance procedure for CMVSS 216 and FMVSS 216a on all Incomplete Vehicle Models 4536 kg (10,000 lb.) GVWR or less Contained in this Document

TYPE 3 The following statement is applicable to all types of incomplete vehicles contained in this document (unless otherwise noted on the cover).

Conformity with CMVSS 220 and FMVSS 220 cannot be determined based upon the components supplied on the incomplete vehicle, and General Motors makes no representation to conformity with the standard.

FMVSS 225 – CHILD RESTRAINT ANCHORAGE SYSTEMS
Applies to all types of Incomplete Vehicles Contained in this Document
3855 kg (8,500 lb.) GVWR or less

TYPE 1 The following statements are applicable to all types of incomplete vehicles contained in this document with seats installed by General Motors (unless otherwise noted on the cover).

This incomplete vehicle, when completed, will conform to FMVSS 225 provided the original equipment seats are not replaced, no seating positions are removed or added, and no alterations are made which affect the function, physical, chemical, or mechanical properties, environment, location or vital spatial clearances of the components, assemblies or systems, as manufactured by General Motors, including but not limited to those listed below:

Airbag manual cut-off switch (if equipped)	Owner Manual instructions
Child restraint system including lower and top tether anchorages, seat brackets, plates and reinforcements	Seat assemblies
Access to top tether and lower anchorage systems	Seat belt assemblies
Floor pan assembly	Seat belt anchorage brackets, plates, and reinforcements
Head restraints / head rests	Seat belt routing
	Seat position/adjustment capability

TYPE 3 The following statement is applicable to all types of incomplete vehicles contained in this document with seat or seat belt delete options in any seating position (unless otherwise noted on the cover).

Conformity with FMVSS 225 cannot be determined based upon the components supplied on the incomplete vehicle, and General Motors makes no representation to conformity with the standard.

CMVSS 226 and FMVSS 226 – EJECTION MITIGATION
Applies to all types of Incomplete Vehicles Contained in this Document
4536 kg (10,000 lb.) GVWR or less

TYPE 1 The following statement is applicable to all types of incomplete vehicles contained in this document, 4536 kg (10,000 lb.) GVWR or less (unless otherwise noted on the cover).

This incomplete vehicle, when completed, will conform to CMVSS 226 and FMVSS 226 providing no alterations are made which affect the function, physical, chemical, or mechanical properties, environment, location or vital spatial clearances of the components, assemblies or systems, as manufactured by General Motors, including but not limited to those listed below:

A, B, C pillar structure	Roof structure
Air bag system	Seat adjusters
Assist handles	Seats, seat backs and head restraints
Body structure	Seat air bag
Door pads	Sensing diagnostic module (SDM)
Door structure	Sunvisors
Headliner	Upper interior trim
Instrument panel	Window Glazing

TYPE 3 The following statement is applicable to all types of incomplete vehicles contained in this document upfitted with a partition between the first and second row (crew cab, extended cab, utility) and/or second and third row (utility model only).

Conformity with CMVSS 226 and FMVSS 226 cannot be determined based upon the components supplied on the incomplete vehicle, and General Motors makes no representation to conformity with the standard.

CMVSS 301 and FMVSS 301 – FUEL SYSTEM INTEGRITY
Refer to Vehicle Types, GVWRs, and Applicable Statements that follow

TYPE 2 The following statement is applicable to all types of incomplete vehicles contained in this document 4536 kg (10,000 lb.) GVWR or less with any Incomplete Option (unless otherwise noted on the cover).

This incomplete vehicle, when completed, will conform to CMVSS 301 and FMVSS 301 providing it is completed in accordance with the following specific conditions by the (intermediate and) final stage manufacturer:

A. The following items when installed by General Motors will conform providing no alterations are made which affect the function, physical, chemical, or mechanical properties, environment, location or vital spatial clearances of the components, assemblies or systems, as manufactured by General Motors, including but not limited to those listed below:

Fuel filler door assembly	Fuel tank filler neck/pipe assembly
Fuel filter	Fuel tank filler neck/pipe fasteners
Fuel hose shields	Fuel tank filler neck/pipe hose clamp/clamp assembly
Fuel pipes and hose assemblies	Fuel tank filler neck/pipe housing assembly
Fuel system	Fuel tank filler neck/pipe plate
Fuel system attaching or protective structure	Fuel tank filler neck/pipe vent hose
Fuel system control module	Fuel tank filler neck/pipe vent hose clamp/strap
Fuel system fasteners and retainers	Fuel tank meter assembly
Fuel tank assembly	Fuel tank shields
Fuel tank cap assembly	Fuel vapor lines and canister assembly
Fuel tank filler neck hose	

B. The (intermediate and) final stage manufacturer conforms to the following:

1. a box, platform, or other rear structural assembly must be installed on the back of the vehicle.
2. the rear assembly structure must provide comparable stiffness to the pickup box sold as original equipment as part of the complete vehicle version of this product.

3. the method of rear assembly structure mounting and mount properties (material and structural) are similar to those used to attach the pickup box sold as original equipment as part of the complete vehicle version of this product.
 4. The dimension and mass as well as other restrictions (excluding the Maximum Frontal Area) found in MVSS 301 Table A, are not exceeded.
- C. This incomplete vehicle, when completed, will conform to CMVSS 301 and FMVSS 301 Fuel System Integrity if:
1. No alterations are made to the fuel system and attaching or protective structure, the contents or arrangement of the engine compartment, the powertrain and driveline, the cab structure, the chassis structure, the bumper system, door structure, or tires and wheels.
 2. The dimension and mass as well as other restrictions (excluding the Maximum Frontal Area) found in MVSS 301 Table A, are not exceeded.
 3. The final stage manufacturer completes the fuel filler neck and fuel level sender installation(s) according to “Best Practices” or “Special Applications (if applicable)” sections found within the Body Builder Manuals on **the GM Upfitter Integration website located at www.gmupfitter.com**
 4. During all barrier impact tests:
 - a. No component installed by any intermediate or final stage manufacturer impinges or causes distortion to the fuel system with sufficient energy to puncture or separate the fuel system.
 - b. No vehicle modification by any intermediate or final stage manufacturer results in any portion of the vehicle impinging upon or causing distortion to the fuel system with sufficient energy to puncture or separate the fuel system. Care should be taken that the structural integrity of the vehicle is restored following any modification of the structure.
 - c. Any body installed by an intermediate or final stage manufacturer is mounted securely to absorb loads and prevent movement relative to the frame which could cause any fuel system component to be punctured, separated or otherwise damaged when tested to applicable procedures of CMVSS 301 or FMVSS 301.

TABLE A

Models	GVWR kg (lb.) (RPO)	Engine (RPO)	General Body Types	Maximum Body Center of Gravity Height cm (in)	Maximum Body Height cm (in)	Maximum Unloaded Vehicle Weight (Completed Vehicle Maximum Weight) kg (lb.)	Maximum Body Weight kg (lb.)
C10706 PPV Utility	3,357 (7,400) (C6C)	Gas (L84)	Utility	Not Applicable	Not Applicable	2,699 (5,950)	Not Applicable (Not to exceed max ULVW)
K10706 PPV Utility	3,447 (7,600) (C6G)	Gas (L84)	Utility	Not Applicable	Not Applicable	2,699 (5,950)	Not Applicable (Not to exceed max ULVW)

Models	GVWR kg (lb.) (RPO)	Engine (RPO)	General Body Types	Maximum Body Center of Gravity Height cm (in)	Maximum Body Height cm (in)	Maximum Unloaded Vehicle Weight (Completed Vehicle Maximum Weight) kg (lb.)	Maximum Body Weight kg (lb.)
K10706 Muni Utility	3,447 (7,600) (C6G)	Gas (L84)	Utility	Not Applicable	Not Applicable	2,699 (5,950)	Not Applicable (Not to exceed max ULVW)
C10903 Regular Cab	3084 (6800) (C5U)	5.3L Gas (L84)	Service Body	35.6 (14.0) above the frame	Under 157.5 cm (62.0)	2472 (5,450)	499 (1,100)
K10903 Regular Cab	3130 (6900) (C5H)	5.3L Gas (L84)	Service Body	35.6 (14.0) above the frame	Under 157.5 cm (62.0)	2472 (5,450)	499 (1,100)
C20903 Regular Cab	4,491 (9,900) (C4M)	Gas (L8T)	Service Body	51.6 (20.3) above the frame	157.5 (62.0) and over	3,817 (8,415)	1,210 (2,670)
C20903 Regular Cab	4,536 (10,000) (C7A)	Gas (L8T)	Service Body	51.6 (20.3) above the frame	157.5 (62.0) and over	3,856 (8,500)	1,250 (2,760)
C20953 Double Cab	4,491 (9,900) (C4M)	Gas (L8T)	Service Body	51.6 (20.3) above the frame	157.5 (62.0) and over	3,817 (8,415)	1,010 (2,230)
C20953 Double Cab	4,536 (10,000) (C7A)	Gas (L8T)	Service Body	51.6 (20.3) above the frame	157.5 (62.0) and over	3,856 (8,500)	1,050 (2,310)
C20943 Crew Cab	4,491 (9,900) (C4M)	Diesel (L5P)	Service Body	51.6 (20.3) above the frame	157.5 (62.0) and over	3,817 (8,415)	640 (1,400)
C20943 Crew Cab	4,491 (9,900) (C4M)	Gas (L8T)	Service Body	51.6 (20.3) above the frame	157.5 (62.0) and over	3,817 (8,415)	950 (2,090)
C20943 Crew Cab	4,536 (10,000) (C7A)	Diesel (L5P)	Service Body	51.6 (20.3) above the frame	157.5 (62.0) and over	3,856 (8,500)	680 (1,490)
C20943 Crew Cab	4,536 (10,000) (C7A)	Gas (L8T)	Service Body	51.6 (20.3) above the frame	157.5 (62.0) and over	3,856 (8,500)	990 (2,180)
K20903 Regular Cab	4,491 (9,900) (C4M)	Gas (L8T)	Service Body	51.6 (20.3) above the frame	157.5 (62.0) and over	3,817 (8,415)	1,030 (2,280)
K20903 Regular Cab	4,536 (10,000) (C7A)	Gas (L8T)	Service Body	51.6 (20.3) above the frame	157.5 (62.0) and over	3,856 (8,500)	1,070 (2,370)
K20953 Double Cab	4,491 (9,900) (C4M)	Diesel (L5P)	Service Body	51.6 (20.3) above the frame	157.5 (62.0) and over	3,817 (8,415)	540 (1,180)

Models	GVWR kg (lb.) (RPO)	Engine (RPO)	General Body Types	Maximum Body Center of Gravity Height cm (in)	Maximum Body Height cm (in)	Maximum Unloaded Vehicle Weight (Completed Vehicle Maximum Weight) kg (lb.)	Maximum Body Weight kg (lb.)
K20953 Double Cab	4,491 (9,900) (C4M)	Gas (L8T)	Service Body	51.6 (20.3) above the frame	157.5 (62.0) and over	3,817 (8,415)	850 (1,870)
K20953 Double Cab	4,536 (10,000) (C7A)	Diesel (L5P)	Service Body	51.6 (20.3) above the frame	157.5 (62.0) and over	3,856 (8,500)	580 (1,270)
K20953 Double Cab	4,536 (10,000) (C7A)	Gas (L8T)	Service Body	51.6 (20.3) above the frame	157.5 (62.0) and over	3,856 (8,500)	890 (1,960)
K20943 Crew Cab	4,491 (9,900) (C4M)	Diesel (L5P)	Service Body	51.6 (20.3) above the frame	157.5 (62.0) and over	3,817 (8,415)	500 (1,100)
K20943 Crew Cab	4,491 (9,900) (C4M)	Gas (L8T)	Service Body	51.6 (20.3) above the frame	157.5 (62.0) and over	3,817 (8,415)	810 (1,780)
K20943 Crew Cab	4,536 (10,000) (C7A)	Diesel (L5P)	Service Body	51.6 (20.3) above the frame	157.5 (62.0) and over	3,856 (8,500)	540 (1,180)
K20943 Crew Cab	4,536 (10,000) (C7A)	Gas (L8T)	Service Body	51.6 (20.3) above the frame	157.5 (62.0) and over	3,856 (8,500)	850 (1,870)

Notes:

- **Table A above applies to ONLY incomplete vehicles (RPO: &VXT) as manufactured by GM without pick-up boxes (RPO: &ZW9).**
- On page 2 within this document, before each vehicle illustration and after the word TYPE, is a list of types of vehicles into which the incomplete vehicle is designed to be manufactured. For the allowable vehicle TYPE(s), CMVSS 301 and FMVSS 301 only applies to vehicles with a 4536 kg (10,000 lb.) GVWR or less. As a result, Table A does not include data for GVWRs exceeding 4536 kg (10,000 lb.) GVWR.
- For all included models, the minimum cab to body clearance is 7.6 cm (3.0 in)
- CA (back of cab sheet metal to centerline of rear axle dimensions) are located within the “General Arrangement” section found within the **GM Upfitter Integration website located at www.gmupfitter.com**
- * The Maximum Frontal Area column applies to: PART II, U.S. EPA, CALIFORNIA, AND CANADIAN EXHAUST & EVAPORATIVE EMISSION REQUIREMENTS AND EPA/NHTSA GREENHOUSE GAS/ FUEL ECONOMY REGULATIONS.
- The completed vehicle Maximum Unloaded Vehicle (Curb) Weight, and/or GVWR, and/or frontal area should not be exceeded. If any of these restrictions are exceeded, re-certification by the final stage manufacturer will be required.
- The Maximum Body Weight equals the Maximum Unloaded Vehicle (curb) Weight minus the incomplete Cab & Chassis (curb) weight as manufactured by GM. The actual vehicle (curb) weight must be determined by weighing the vehicle with fuel and fluids filled, minus occupants and cargo. The Maximum Body Weight in Table A is based on the maximum possible incomplete Cab & Chassis (curb) weight as manufactured by GM. It may be permissible to exceed the Maximum Body Weight (as stated in Table A), provided the Maximum Unloaded Vehicle (curb) Weight (as stated in Table A) is not exceeded at final stage manufacturer completion.
- Also see the Vehicle Emission Control Information Label in the vehicle engine compartment for maximum completed vehicle curb weight, GVWR, and frontal area restrictions, if applicable.
- Note: WB refers to wheelbase; GVWR refers to Gross Vehicle Weight Rating.

CMVSS 301.1 – LPG FUEL SYSTEM INTEGRITY
Applies to all types of Incomplete Vehicles contained in this Document

TYPE 3 The following statement is applicable to all types of incomplete vehicles contained in this document (unless otherwise noted on the cover).

Conformity with CMVSS 301.1 cannot be determined based upon the components supplied on the incomplete vehicle, and General Motors makes no representation to conformity with the standard.

CMVSS 302 and FMVSS 302 – FLAMMABILITY OF INTERIOR MATERIALS
Applies to all types of Incomplete Vehicles contained in this Document

TYPE 1 The following statement is applicable to all types of incomplete vehicles contained in this document (unless otherwise noted on the cover).

This incomplete vehicle, when completed will conform to CMVSS 302 and FMVSS 302 providing no alterations are made which affect the function, physical, chemical, or mechanical properties, environment, location or vital spatial clearances of the components, assemblies or systems, as manufactured by General Motors, including but not limited to those listed below:

All trim panels including door, front, rear and side panels	Instrument panel
Arm rests	Seat assemblies
Compartment shelves	Seat backs
Console	Seat belts
Engine compartment covers	Seat cushions
Floor coverings	Shades
Head restraints	Sun visors
Headlining	Wheel housing covers

NOTE: The list above also includes any other interior materials, such as padding and crash deployed elements that are designed to absorb energy on contact by occupants in the event of a crash.

TYPE 3 The following statement is applicable to all types of incomplete vehicles contained in this document (unless otherwise noted on the cover). If the intermediate or final stage manufacturer installs any items but not limited to those listed above (examples: Curtains, Engine compartment cover, Mattress covers, Shades and Wheel housing covers, etc.), they must also meet the requirements of this CMVSS 302 and FMVSS 302.

Conformity with CMVSS 302 and FMVSS 302 cannot be determined based upon the components supplied on the incomplete vehicle, and General Motors makes no representation to conformity with the standard.

CMVSS 301.2 and FMVSS 303 – CNG FUEL SYSTEM INTEGRITY
Applies to all types of Incomplete Vehicles contained in this Document

TYPE 3 The following statement is applicable to all types of incomplete vehicles contained in this document (unless otherwise noted on the cover).

Conformity with CMVSS 301.2 and FMVSS 303 cannot be determined based upon the components supplied on the incomplete vehicle, and General Motors makes no representation to conformity with the standard.

FMVSS 304 – COMPRESSED NATURAL GAS FUEL CONTAINERS
Applies to all types of Incomplete Vehicles contained in this Document

TYPE 3 The following statement is applicable to all types of incomplete vehicles contained in this document (unless otherwise noted on the cover).

Conformity with FMVSS 304 cannot be determined based upon the components supplied on the incomplete vehicle, and General Motors makes no representation to conformity with the standard.

FMVSS 403 – PLATFORM LIFT SYSTEMS

Applies to all types of Incomplete Vehicles contained in this Document

TYPE 3 The following statement is applicable to all types of incomplete vehicles contained in this document (unless otherwise noted on the cover).

Conformity with FMVSS 403 cannot be determined based upon the components supplied on the incomplete vehicle, and General Motors makes no representation to conformity with the standard.

FMVSS 404 – PLATFORM LIFT INSTALLATIONS IN MOTOR VEHICLES

Applies to all types of Incomplete Vehicles contained in this Document

TYPE 3 The following statement is applicable to all types of incomplete vehicles contained in this document (unless otherwise noted on the cover).

Conformity with FMVSS 404 cannot be determined based upon the components supplied on the incomplete vehicle, and General Motors makes no representation to conformity with the standard.

PART II

U.S. EPA, CALIFORNIA, AND CANADIAN EXHAUST & EVAPORATIVE EMISSION REQUIREMENTS AND EPA/NHTSA GREENHOUSE GAS EMISSIONS/FUEL ECONOMY REGULATIONS

Incomplete vehicles come in three major classifications: (1) Light Duty Vehicles, Light Duty Trucks, and Heavy Duty Vehicles (Including Medium Duty in California) are certified by the primary manufacturer and the vehicle is labeled as being in compliance with emission and fuel economy requirements. (2) Heavy Duty Vehicles are required to have an engine certified by the engine manufacturer and bear an engine emissions label, and if a gasoline vehicle, also bear an evaporative emissions label. (3) Light Duty Vehicles certified and labeled by the intermediate or final stage vehicle manufacturer as being in compliance with emission and fuel economy requirements.

Reference PART I CMVSS 301 and FMVSS 301 Table A, and PART II Table B. The completed vehicle Maximum Unloaded Vehicle (Curb) Weight, GVWR, and/or Maximum Frontal Area restrictions shown in Tables A and B should not be exceeded. If any of these restrictions are exceeded, re-certification by the final stage manufacturer will be required.

In addition, all gasoline/gasoline-ethanol blend powered Federal/California Light Duty, Medium Duty and Heavy Duty Vehicles are required to have an approved fuel evaporative emission control system. Vehicles certified to Heavy Duty gasoline emission standards also require special evaporative emission labeling. In order to assure that Environmental Protection Agency (EPA), National Highway Traffic Safety Administration (NHTSA), California and Canada Emission Certification and/or Greenhouse Gas/Fuel Economy regulations are met, this vehicle must be completed in strict accordance with all instructions contained in this document, especially the following instructions which relate to:

EMISSION RELATED COMPONENTS

TYPE 1 The following statement is applicable to all types of incomplete vehicles contained in this document (unless otherwise noted on the cover).

- A. This incomplete vehicle, when completed, will conform to U.S. EPA, CALIFORNIA, AND CANADIAN EXHAUST & EVAPORATIVE EMISSION REQUIREMENTS AND EPA/NHTSA GREENHOUSE GAS EMISSIONS/FUEL ECONOMY REGULATIONS providing the vehicle is completed in strict accordance with all statements included in this document, especially those that relate to: "EMISSION RELATED COMPONENTS, and no alterations are made which affect the function, physical, chemical, or mechanical properties, environment, location or vital spatial clearances of the components, assemblies or systems, as manufactured by General Motors, including but not limited to those listed below (if equipped):

Air Injection Reaction (AIR) System	crankcase emission control system, evaporative
Axle	emission control system, Exhaust Gas Recirculation
Brake System	(EGR) system, fuel delivery and injection system,
Catalytic Converter	glow plugs, Glow Plug Control Module (GPCM),
Components for All Wheel Drive (AWD) System: axle,	ignition system, Positive Crankcase Ventilation (PCV)
Power Take-Off Unit (PTU), propshaft	system
Diesel Exhaust Emission Reduction Fluid (DEF)	Engine Electronics, including, but not limited to:
system, including, but not limited to: associated	coolant temperature sensor, ECM/GPCM/PCM/VCM,
plumbing, fill neck assembly heated delivery line,	engine speed sensor, mass air flow sensor,
heater, injector, level sensor, pump, sensors, tank	calibrations/software
temperature sensor	Exhaust oxygen sensors
Diesel Exhaust System, including, but not limited to:	Exhaust system
Nox Sensors, Nox Sensor Control Module, Diesel	Intake System, including, but not limited to: air
Exhaust (HCI) Direct Fuel Injector System,	induction components/system ducts, filter, mass air
associated plumbing, injectors, injector controller and	flow sensor, intake air heater
calibrations	

Diesel/Bio-Diesel blend Particulate Filter (DPF) system, including, but not limited to: diesel/bio-diesel blend particulate filter assembly diesel/bio-diesel blend oxidation catalyst assembly, exhaust system pressure differential assembly and/or plumbing, exhaust temperature sensor	Onboard Diagnostics Emission System Tires and Wheels Transaxle/Transmission Assembly Transaxle/Transmission Electronics, including, but not limited to: calibrations/software Transmission Control Module (TCM)
Engine Assembly, including, but not limited to: cooling fan and drive system,	Turbo Charging System, associated equipment and controls

NOTE: The Tailpipe Rear Cooler Assembly is non-emissions related. If equipped, to ensure adequate control of exhaust temperature, the intermediate or final stage manufacturer must complete tailpipe (loose kit) installations according to the instructions provided.

- B. Cold tire pressure as listed for front and rear on the Incomplete Vehicle Label affixed to the front cover of this document must be maintained.
- C. GVWR, GAWR front and rear weight ratings as listed on the Incomplete Vehicle Label affixed to the front cover of this document must not be exceeded.

TABLE B

Models	GVWR kg (lb.) (RPO)	Engine (RPO)	Maximum Unloaded Vehicle Weight kg (lb.)	Service Body Type Maximum Frontal Area m² (ft²)	Dump Body Type Maximum Frontal Area m² (ft²)	Platform with Bulk Head Body Type Maximum Frontal Area m² (ft²)	Hi-Cube Body Type Maximum Frontal Area m² (ft²)
C10903 Regular Cab	3084 (6800) (C5U)	5.3L Gas (L84)	2472 (5,450)	3.62 (39)	N/A	N/A	N/A
K10903 Regular Cab	3130 (6900) (C5H)	5.3L Gas (L84)	2472 (5,450)	3.62 (39)	N/A	N/A	N/A
C20903 Regular Cab	4,491 (9,900) (C4M)	Gas (L8T)	3,817 (8,415)	5.2 (56)	N/A	3.5 (37.7)	N/A
C20903 Regular Cab	4,536 (10,000) (C7A)	Gas (L8T)	3,856 (8,500)	5.2 (56)	N/A	3.5 (37.7)	N/A
C20953 Double Cab	4,491 (9,900) (C4M)	Gas (L8T)	3,817 (8,415)	5.2 (56)	N/A	3.5 (37.7)	N/A
C20953 Double Cab	4,536 (10,000) (C7A)	Gas (L8T)	3,856 (8,500)	5.2 (56)	N/A	3.5 (37.7)	N/A
C20943 Crew Cab	4,491 (9,900) (C4M)	Diesel (L5P)	3,817 (8,415)	5.2 (56)	N/A	3.5 (37.7)	N/A
C20943 Crew Cab	4,491 (9,900) (C4M)	Gas (L8T)	3,817 (8,415)	5.2 (56)	N/A	3.5 (37.7)	N/A
C20943 Crew Cab	4,536 (10,000) (C7A)	Diesel (L5P)	3,856 (8,500)	5.2 (56)	N/A	3.5 (37.7)	N/A
C20943 Crew Cab	4,536 (10,000) (C7A)	Gas (L8T)	3,856 (8,500)	5.2 (56)	N/A	3.5 (37.7)	N/A
K20903 Regular Cab	4,491 (9,900) (C4M)	Gas (L8T)	3,817 (8,415)	5.2 (56)	N/A	3.5 (37.7)	N/A
K20903 Regular Cab	4,536 (10,000) (C7A)	Gas (L8T)	3,856 (8,500)	5.2 (56)	N/A	3.5 (37.7)	N/A
K20953 Double Cab	4,491 (9,900) (C4M)	Diesel (L5P)	3,817 (8,415)	5.2 (56)	N/A	3.5 (37.7)	N/A
K20953 Double Cab	4,491 (9,900) (C4M)	Gas (L8T)	3,817 (8,415)	5.2 (56)	N/A	3.5 (37.7)	N/A
K20953 Double Cab	4,536 (10,000) (C7A)	Diesel (L5P)	3,856 (8,500)	5.2 (56)	N/A	3.5 (37.7)	N/A
K20953 Double Cab	4,536 (10,000) (C7A)	Gas (L8T)	3,856 (8,500)	5.2 (56)	N/A	3.5 (37.7)	N/A

Models	GVWR kg (lb.) (RPO)	Engine (RPO)	Maximum Unloaded Vehicle Weight kg (lb.)	Service Body Type Maximum Frontal Area m² (ft²)	Dump Body Type Maximum Frontal Area m² (ft²)	Platform with Bulk Head Body Type Maximum Frontal Area m² (ft²)	Hi-Cube Body Type Maximum Frontal Area m² (ft²)
K20943 Crew Cab	4,491 (9,900) (C4M)	Diesel (L5P)	3,817 (8415)	5.2 (56)	N/A	3.5 (37.7)	N/A
K20943 Crew Cab	4,491 (9,900) (C4M)	Gas (L8T)	3,817 (8,415)	5.2 (56)	N/A	3.5 (37.7)	N/A
K20943 Crew Cab	4,536 (10,000) (C7A)	Diesel (L5P)	3,856 (8,500)	5.2 (56)	N/A	3.5 (37.7)	N/A
K20943 Crew Cab	4,536 (10,000) (C7A)	Gas (L8T)	3,856 (8,500)	5.2 (56)	N/A	3.5 (37.7)	N/A
C20903 Regular Cab	4,695 (10,350) (JGC)	Gas (L8T)	3,991 (8,798)	8.5 (91.5)	6.9 (74.3)	5.6(60.3)	9.5(102.3)
C20903 Regular Cab	4,785 (10,550) (JGE)	Diesel (L5P)	4,068 (8,968)	8.5 (91.5)	6.9 (74.3)	5.6(60.3)	9.5(102.3)
C20903 Regular Cab	4,876 (10,750) (JGG)	Diesel (L5P)	4,145 (9,138)	8.5 (91.5)	6.9 (74.3)	5.6(60.3)	9.5(102.3)
C20953 Double Cab	4,627 (10,200) (JFG)	Gas (L8T)	3,933 (8,670)	8.5 (91.5)	6.9 (74.3)	5.6(60.3)	9.5(102.3)
C20953 Double Cab	4,808 (10,600) (JFJ)	Gas (L8T)	4,087 (9,010)	8.5 (91.5)	6.9 (74.3)	5.6(60.3)	9.5(102.3)
C20953 Double Cab	4,944 (10,900) (JFM)	Diesel (L5P)	4,203 (9,265)	8.5 (91.5)	6.9 (74.3)	5.6(60.3)	9.5(102.3)
C20953 Double Cab	5,034 (11,100) (JFN)	Diesel (L5P)	4,280 (9,435)	8.5 (91.5)	6.9 (74.3)	5.6(60.3)	9.5(102.3)
C20953 Double Cab	5,239 (11,550) (JGN)	Diesel (L5P)	4,453 (9,818)	8.5 (91.5)	6.9 (74.3)	5.6(60.3)	9.5(102.3)
C20943 Crew Cab	4,990 (11,000) (C7E)	Diesel (L5P)	4,241 (9,350)	8.5 (91.5)	6.9 (74.3)	5.6(60.3)	9.5(102.3)
C20943 Crew Cab	4853 (10,700) (JFK)	Gas (L8T)	4,125 (9095)	8.5 (91.5)	6.9 (74.3)	5.6(60.3)	9.5(102.3)
C20943 Crew Cab	4,672 (10,300) (JFH)	Gas (L8T)	3,971 (8,755)	8.5 (91.5)	6.9 (74.3)	5.6(60.3)	9.5(102.3)
C20943 Crew Cab	5,080 (11,200) (JFO)	Diesel (L5P)	4,318 (9,520)	8.5 (91.5)	6.9 (74.3)	5.6(60.3)	9.5(102.3)
C30903 DZW Regular Cab	6,350 (14,000) (G9Y)	Diesel (L5P)	5,398 (11,900)	8.5 (91.5)	6.9 (74.3)	5.6(60.3)	9.5(102.3)

Models	GVWR kg (lb.) (RPO)	Engine (RPO)	Maximum Unloaded Vehicle Weight kg (lb.)	Service Body Type Maximum Frontal Area m² (ft²)	Dump Body Type Maximum Frontal Area m² (ft²)	Platform with Bulk Head Body Type Maximum Frontal Area m² (ft²)	Hi-Cube Body Type Maximum Frontal Area m² (ft²)
C30903 DZW Regular Cab	6,350 (14,000) (G9Y)	Gas (L8T)	5,398 (11,900)	8.5 (91.5)	6.9 (74.3)	5.6(60.3)	9.5(102.3)
C30903 SRW Regular Cab	5,216 (11,500) (G1Y)	Diesel (L5P)	4,434 (9,775)	8.5 (91.5)	6.9 (74.3)	5.6(60.3)	9.5(102.3)
C30903 SRW Regular Cab	(10,950) (CKJ)	Gas (L8T)	4,222 (9,308)	8.5 (91.5)	6.9 (74.3)	5.6(60.3)	9.5(102.3)
C30953 DZW Double Cab	6,350 (14,000) (G9Y)	Diesel (L5P)	5,398 (11,900)	8.5 (91.5)	6.9 (74.3)	5.6(60.3)	9.5(102.3)
C30953 DZW Double Cab	6,350 (14,000) (G9Y)	Gas (L8T)	5,398 (11,900)	8.5 (91.5)	6.9 (74.3)	5.6(60.3)	9.5(102.3)
C30953 SRW Double Cab	5,126 (11,300) (JFP)	Gas (L8T)	4,357 (9,605)	8.5 (91.5)	6.9 (74.3)	5.6(60.3)	9.5(102.3)
C30953 SRW Double Cab	5,375 (11,850) (JGR)	Diesel (L5P)	4,569 (10,073)	8.5 (91.5)	6.9 (74.3)	5.6(60.3)	9.5(102.3)
C30943 DZW Crew Cab	6,350 (14,000) (G9Y)	Diesel (L5P)	5,398 (11,900)	8.5 (91.5)	6.9 (74.3)	5.6(60.3)	9.5(102.3)
C30943 DZW Crew Cab	6,350 (14,000) (G9Y)	Gas (L8T)	5,398 (11,900)	8.5 (91.5)	6.9 (74.3)	5.6(60.3)	9.5(102.3)
C30943 SRW Crew Cab	5,398 (11,900) (G4H)	Diesel (L5P)	4,588 (10,115)	8.5 (91.5)	6.9 (74.3)	5.6(60.3)	9.5(102.3)
C30943 SRW Crew Cab	5,148 (11,350) (JGL)	Gas (L8T)	4,376 (9,648)	8.5 (91.5)	6.9 (74.3)	5.6(60.3)	9.5(102.3)
C31003 Regular Chassis Cab	6,350 (14,000) (G9Y)	Diesel (L5P)	5,398 (11,900)	8.5 (91.5)	6.9 (74.3)	5.6(60.3)	9.5(102.3)
C31003 Regular Chassis Cab	6,350 (14,000) (G9Y)	Gas (L8T)	5,398 (11,900)	8.5 (91.5)	6.9 (74.3)	5.6(60.3)	9.5(102.3)
C31403 Regular Chassis Cab (Long Frame)	6,350 (14,000) (G9Y)	Diesel (L5P)	5,398 (11,900)	8.5 (91.5)	6.9 (74.3)	5.6(60.3)	9.5(102.3)
C31403 Regular Chassis Cab (Long Frame)	6,350 (14,000) (G9Y)	Gas (L8T)	5,398 (11,900)	8.5 (91.5)	6.9 (74.3)	5.6(60.3)	9.5(102.3)
C31043 Crew Chassis Cab	6,350 (14,000) (G9Y)	Diesel (L5P)	5,398 (11,900)	8.5 (91.5)	6.9 (74.3)	5.6(60.3)	9.5(102.3)

Models	GVWR kg (lb.) (RPO)	Engine (RPO)	Maximum Unloaded Vehicle Weight kg (lb.)	Service Body Type Maximum Frontal Area m² (ft²)	Dump Body Type Maximum Frontal Area m² (ft²)	Platform with Bulk Head Body Type Maximum Frontal Area m² (ft²)	Hi-Cube Body Type Maximum Frontal Area m² (ft²)
C31043 Crew Chassis Cab	6,350 (14,000) (G9Y)	Gas (L8T)	5,398 (11,900)	8.5 (91.5)	6.9 (74.3)	5.6(60.3)	9.5(102.3)
K20903 Regular Cab	4,649 (10,250) (JGB)	Gas (L8T)	3,952 (8,713)	8.5 (91.5)	6.9 (74.3)	5.6(60.3)	9.5(102.3)
K20903 Regular Cab	4,831 (10,650) (JGF)	Gas (L8T)	4,106 (9,053)	8.5 (91.5)	6.9 (74.3)	5.6(60.3)	9.5(102.3)
K20903 Regular Cab	4,944 (10,900) (JFM)	Diesel (L5P)	4,203 (9,265)	8.5 (91.5)	6.9 (74.3)	5.6(60.3)	9.5(102.3)
K20903 Regular Cab	4,971 (10,960) (CKM)	Diesel (L5P)	4,225 (9,316)	8.5 (91.5)	6.9 (74.3)	5.6(60.3)	9.5(102.3)
K20903 Regular Cab	5,001 (11,025) (CKF)	Diesel (L5P)	4,251 (9,371)	8.5 (91.5)	6.9 (74.3)	5.6(60.3)	9.5(102.3)
K20953 Double Cab	4,763 (10,500) (C7G)	Gas (L8T)	4,048 (8,925)	8.5 (91.5)	6.9 (74.3)	5.6(60.3)	9.5(102.3)
K20953 Double Cab	4,967 (10,950) (CKJ)	Gas (L8T)	4,222 (9308)	8.5 (91.5)	6.9 (74.3)	5.6(60.3)	9.5(102.3)
K20953 Double Cab	5,080 (11,200) (JFO)	Diesel (L5P)	4,318 (9,520)	8.5 (91.5)	6.9 (74.3)	5.6(60.3)	9.5(102.3)
K20953 Double Cab	5,194 (11,450) (JGM)	Diesel (L5P)	4,415 (9,733)	8.5 (91.5)	6.9 (74.3)	5.6(60.3)	9.5(102.3)
K20953 Double Cab	5,330 (11,750) (JGP)	Diesel (L5P)	4,530 (9,988)	8.5 (91.5)	6.9 (74.3)	5.6(60.3)	9.5(102.3)
K20943 Crew Cab	4,831 (10,650) (JGF)	Gas (L8T)	4,106 (9,053)	8.5 (91.5)	6.9 (74.3)	5.6(60.3)	9.5(102.3)
K20943 Crew Cab	5,013 (11,050) (JGJ)	Gas (L8T)	4,260 (9,393)	8.5 (91.5)	6.9 (74.3)	5.6(60.3)	9.5(102.3)
K20943 Crew Cab	5,148 (11,350) (JGL)	Diesel (L5P)	4,376 (9,648)	8.5 (91.5)	6.9 (74.3)	5.6(60.3)	9.5(102.3)
K20943 Crew Cab	5,238 (11,550) (JGN)	Diesel (L5P)	4,453 (9,817)	8.5 (91.5)	6.9 (74.3)	5.6(60.3)	9.5(102.3)

Models	GVWR kg (lb.) (RPO)	Engine (RPO)	Maximum Unloaded Vehicle Weight kg (lb.)	Service Body Type Maximum Frontal Area m² (ft²)	Dump Body Type Maximum Frontal Area m² (ft²)	Platform with Bulk Head Body Type Maximum Frontal Area m² (ft²)	Hi-Cube Body Type Maximum Frontal Area m² (ft²)
K30903 DZW Regular Cab	6,350 (14,000) (G9Y)	Diesel (L5P)	5,398 (11,900)	8.5 (91.5)	6.9 (74.3)	5.6(60.3)	9.5(102.3)
K30903 DZW Regular Cab	6,350 (14,000) (G9Y)	Gas (L8T)	5,398 (11,900)	8.5 (91.5)	6.9 (74.3)	5.6(60.3)	9.5(102.3)
K30903 SRW Regular Cab	5,126 (11,300) (JFP)	Gas (L8T)	4,357 (9,605)	8.5 (91.5)	6.9 (74.3)	5.6(60.3)	9.5(102.3)
K30903 SRW Regular Cab	5,352 (11,800) (JGQ)	Diesel (L5P)	4,550 (10,030)	8.5 (91.5)	6.9 (74.3)	5.6(60.3)	9.5(102.3)
K30953 DZW Double Cab	6,350 (14,000) (G9Y)	Diesel (L5P)	5,398 (11,900)	8.5 (91.5)	6.9 (74.3)	5.6(60.3)	9.5(102.3)
K30953 DZW Double Cab	6,350 (14,000) (G9Y)	Gas (L8T)	5,398 (11,900)	8.5 (91.5)	6.9 (74.3)	5.6(60.3)	9.5(102.3)
K30953 SRW Double Cab	5,262 (11,600) (C7V)	Gas (L8T)	4,472 (9,860)	8.5 (91.5)	6.9 (74.3)	5.6(60.3)	9.5(102.3)
K30953 SRW Double Cab	5,511 (12,150) (JGS)	Diesel (L5P)	4,684 (10,328)	8.5 (91.5)	6.9 (74.3)	5.6(60.3)	9.5(102.3)
K30943 DZW Crew Cab	6,350 (14,000) (G9Y)	Diesel (L5P)	5,398 (11,900)	8.5 (91.5)	6.9 (74.3)	5.6(60.3)	9.5(102.3)
K30943 DZW Crew Cab	6,350 (14,000) (G9Y)	Gas (L8T)	5,398 (11,900)	8.5 (91.5)	6.9 (74.3)	5.6(60.3)	9.5(102.3)
K30943 SRW Crew Cab	5,307 (11,700) (G3I)	Gas (L8T)	4,511 (9,945)	8.5 (91.5)	6.9 (74.3)	5.6(60.3)	9.5(102.3)
K30943 SRW Crew Cab	5,557 (12,250) (JGT)	Diesel (L5P)	4,723 (10,413)	8.5 (91.5)	6.9 (74.3)	5.6(60.3)	9.5(102.3)
K31003 Regular Chassis Cab	6,350 (14,000) (G9Y)	Diesel (L5P)	5,398 (11,900)	8.5 (91.5)	6.9 (74.3)	5.6(60.3)	9.5(102.3)
K31003 Regular Chassis Cab	6,350 (14,000) (G9Y)	Gas (L8T)	5,398 (11,900)	8.5 (91.5)	6.9 (74.3)	5.6(60.3)	9.5(102.3)
K31403 Regular Chassis Cab (Long Frame)	6,350 (14,000) (G9Y)	Diesel (L5P)	5,398 (11,900)	8.5 (91.5)	6.9 (74.3)	5.6(60.3)	9.5(102.3)
K31403 Regular Chassis Cab (Long Frame)	6,350 (14,000) (G9Y)	Gas (L8T)	5,398 (11,900)	8.5 (91.5)	6.9 (74.3)	5.6(60.3)	9.5(102.3)
K31043 Crew Chassis Cab	6,350 (14,000) (G9Y)	Diesel (L5P)	5,398 (11,900)	8.5 (91.5)	6.9 (74.3)	5.6(60.3)	9.5(102.3)

Models	GVWR kg (lb.) (RPO)	Engine (RPO)	Maximum Unloaded Vehicle Weight kg (lb.)	Service Body Type Maximum Frontal Area m ² (ft ²)	Dump Body Type Maximum Frontal Area m ² (ft ²)	Platform with Bulk Head Body Type Maximum Frontal Area m ² (ft ²)	Hi-Cube Body Type Maximum Frontal Area m ² (ft ²)
K31043 Crew Chassis Cab	6,350 (14,000) (G9Y)	Gas (L8T)	5,398 (11,900)	8.5 (91.5)	6.9 (74.3)	5.6(60.3)	9.5(102.3)

Notes:

- **Table B above applies to ONLY incomplete vehicles (RPO: &VXT) manufactured by GM without pick-up boxes (RPO: &ZW9).**
- On page 2 within this document, before each vehicle illustration and after the word TYPE, is a list of types of vehicles into which the incomplete vehicle is designed to be manufactured.
- For all included models, the minimum cab to body clearance is 7.6 cm (3.0 in)
- CA (back of cab sheet metal to centerline of rear axle dimensions) are located within the **GM Upfitter Integration website located at www.gmupfitter.com**
- * The Maximum Frontal Area columns apply to: PART II, U.S. EPA, CALIFORNIA, AND CANADIAN EXHAUST & EVAPORATIVE EMISSION REQUIREMENTS AND EPA/NHTSA GREENHOUSE GAS/FUEL ECONOMY REGULATIONS.
- The completed vehicle Maximum Unloaded Vehicle (Curb) Weight, and/or GVWR, and/or frontal area should not be exceeded. If any of these restrictions are exceeded, re-certification by the final stage manufacturer will be required.
- The Maximum Body Weight equals the Maximum Unloaded Vehicle (curb) Weight minus the incomplete Cab & Chassis (curb) weight as manufactured by GM. The actual vehicle (curb) weight must be determined by weighing the vehicle with fuel and fluids filled, minus occupants and cargo.
- Also see the Vehicle Emission Control Information Label in the vehicle engine compartment for maximum completed vehicle curb weight, GVWR, and frontal area restrictions, if applicable.
- GVWR refers to Gross Vehicle Weight Rating.
- All Federal/California gasoline/gasoline-ethanol blend powered heavy duty vehicles (except those equipped with option NJ2, Temporary Fuel Tank) will have an evaporative emission control system that is certified for a fuel tank capacity for the vehicle as built. Intermediate or Final Stage Manufacturers wishing to add fuel tank capacity beyond the original equipment fuel tank capacity must recertify that the Modified Fuel System meets Evaporative Emission Regulations in effect at the time of original vehicle manufacture. Compliance with applicable exhaust and evaporative emission requirements is the responsibility of the final stage manufacturer.

- D. Further compliance with applicable fuel evaporative emissions requirements will be maintained providing the intermediate or final stage manufacturer completes the fuel filler neck and fuel level sender installation(s) according to “Best Practices” or “Special Applications (if applicable)” sections found within the Body Builder Manuals on the **GM Upfitter Integration website located at www.gmupfitter.com**

Compliance with applicable fuel evaporative emission regulations will be maintained if no alterations are made to change material or increase the size or length or position of the following non-metallic fuel and evaporative emission hoses:

Fuel feed hoses front and rear	Fuel vapor lines at canister
Fuel return hoses front and rear	Fuel vapor lines from engine to chassis pipes
Fuel tank filler hoses to filler neck	Fuel vapor lines from fuel tank sender to chassis pipes
Fuel tank vent hoses to filler neck	

- E. The following is applicable to models with option NJ2 – Temporary Fuel Tank. Vehicles equipped with option NJ2 - Temporary Fuel Tank do not have an evaporative emission control system.

Compliance with applicable exhaust and evaporative emission requirements is the responsibility of the final stage manufacturer. General Motors makes no representation as to the conformity with applicable exhaust and evaporative emission requirements based upon the components supplied on the incomplete vehicle.

A final stage manufacturer who retains the original equipment gasoline/gasoline-ethanol blend powered engine as certified by General Motors may purchase original equipment evaporative emission control system components (see your GM dealer) necessary for the final stage vehicle to comply with evaporative emissions requirements. It is the responsibility of the final stage manufacturer to determine the components necessary to ensure evaporative emissions compliance.

TYPE 3 The following statement is applicable to all types of incomplete vehicles contained in this document manufactured with a gasoline engine, and having an auxiliary heat exchanger installed in the engine cooling system by a subsequent stage manufacturer (unless otherwise noted on the cover).

Conformity with CMVSS, U.S. EPA, CALIFORNIA, AND CANADIAN EXHAUST & EVAPORATIVE EMISSION REQUIREMENTS AND EPA FUEL ECONOMY REGULATIONS cannot be determined based upon the components supplied on the incomplete vehicle, and General Motors makes no representation to conformity with the regulations.

NOTE: This non-permitted modification will continually set Service Engine Diagnostic Codes.

SPECIFICATION FOR FILL PIPES AND OPENINGS OF 2015 AND SUBSEQUENT MODEL MOTOR VEHICLE FUEL TANKS (APPLICABLE ONLY TO CALIFORNIA GASOLINE/GASOLINE-ETHANOL BLEND POWERED VEHICLES)

TYPE 2 The following statement is applicable to all types of incomplete vehicles contained in this document (unless otherwise noted on the cover).

This incomplete vehicle, when completed, will conform to Title 13, California Code of Regulations Section 2235, and the "Specifications for Fill Pipes and Openings of 2015 and subsequent Model Year Motor Vehicle Fuel Tanks", dated March 22, 2012, providing no alterations are made which affect the function, physical, chemical, or mechanical properties, environment, location or vital spatial clearances of the fuel filler neck(s) and any intermediate or final stage manufacturer completes the fuel filler neck installation(s) according to the instructions which are furnished in the loose parts box.

LABELS

TYPE 2 The following statement is applicable to all types of incomplete vehicles contained in this document (unless otherwise noted on the cover).

This incomplete vehicle, when completed, will conform to U.S. EPA, CALIFORNIA, AND CANADIAN EXHAUST & EVAPORATIVE EMISSION REQUIREMENTS AND EPA/NHTSA GREENHOUSE GAS EMISSIONS/FUEL ECONOMY REGULATION labeling requirements providing no alterations are made which affect the function, physical, chemical, or mechanical properties, environment, location or vital spatial clearances of the Emission Control related Information Labels that are permanently affixed. The labels are required by government regulation and must not be obstructed from view or defaced so as to impair their visibility or legibility. In addition, an EPA/DOT Fuel Economy and Environment-Label may be affixed to the window glass of the incomplete vehicle as manufactured by General Motors. If equipped, the label must remain in place until this vehicle is received by the ultimate customer.

NOTES
